

Protect^{IT} – MNS Motor Management INSUM[®]

Technical Information



Industrial^{IT}
enabled™



The Industrial^{IT} wordmark and all product names in the form XXXXX^{IT} are registered or pending trademarks of ABB.

Emax is a registered trademark of ABB SACE Spa.

MNS, INSUM and PRODAT are registered trademarks of ABB Schaltanlagentechnik GmbH.

Microsoft, Windows and Windows NT are registered trademarks of Microsoft Corporation.

LON, LonTalk, LONWORKS, NEURON are registered trademarks of Echelon Corporation.

MODBUS is a registered trademark of Schneider Automation.

PROFIBUS is a registered trademark of PROFIBUS Nutzerorganisation e.V. (PNO).

Technical descriptions relate to Protect IT - MNS Motor Management INSUM, Release 2.3/1.

This product has been certified by ABB Group as Industrial IT EnabledTM- Information Level. All product information is supplied in interactive electronic format, based on ABB Aspect ObjectTM technology.

The Industrial IT commitment from ABB ensures that every enterprise building block is equipped with the integral tools necessary to install, operate, and maintain it efficiently throughout the product lifecycle.

The information in this document is subject to change without notice and should not be construed as a commitment by ABB. ABB assumes no responsibility for any errors that may appear in this document. In no event shall ABB be liable for direct, indirect, special, incidental, or consequential damages of any nature or kind arising from the use of this document, nor shall ABB be liable for incidental or consequential damages arising from use of any software or hardware described in this document.

This document and parts thereof must not be reproduced or copied without ABB's written permission, and the contents thereof must not be imparted to a third party nor be used for any unauthorized purpose. The software described in this document is furnished under a license and may be used, copied, or disclosed only in accordance with the terms of such license.

All rights reserved.

Copyright © 2004 ABB Schaltanlagentechnik GmbH, Ladenburg

Protect^{IT} – MNS Motor Management INSUM

INSUM is an intelligent system based on Power^{IT} - Low Voltage Switchgear MNS, offering superior protection, control and monitoring for user-optimized motor management.

Relevant information from the process – including timely alarms – enable plant operators to make smart decisions on process conditions. Plant availability is significantly improved through preventive actions. Data with quality far beyond conventional motor protection or remote control technology, is utilized by engineering crews for detailed system analysis and need-based maintenance. This brochure provides an overview of the INSUM System, its components, their functions and benefits as well as relevant technical data. Please refer also to our website at www.abb.com/mns.



System Overview

Control system overview showing typical low voltage energy distribution and motor control center communicating upwards to Process Control Systems and sideways to engineering and maintenance stations (INSUM OS). Available in simplex or dual-redundant configuration. Dual-redundant illustrated.

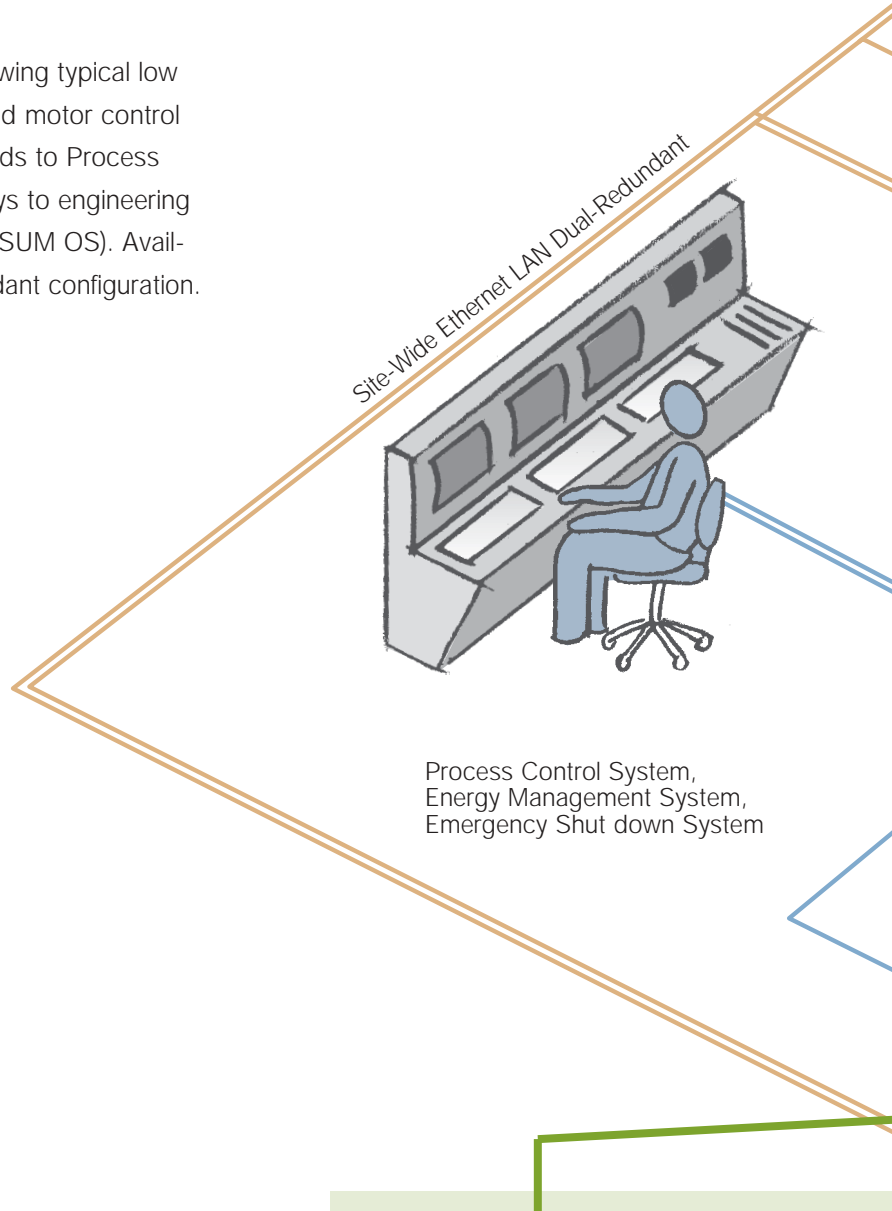

**Integrated Tier Switch (ITS)
SlimLine fitted in MNS LV
switchgear**

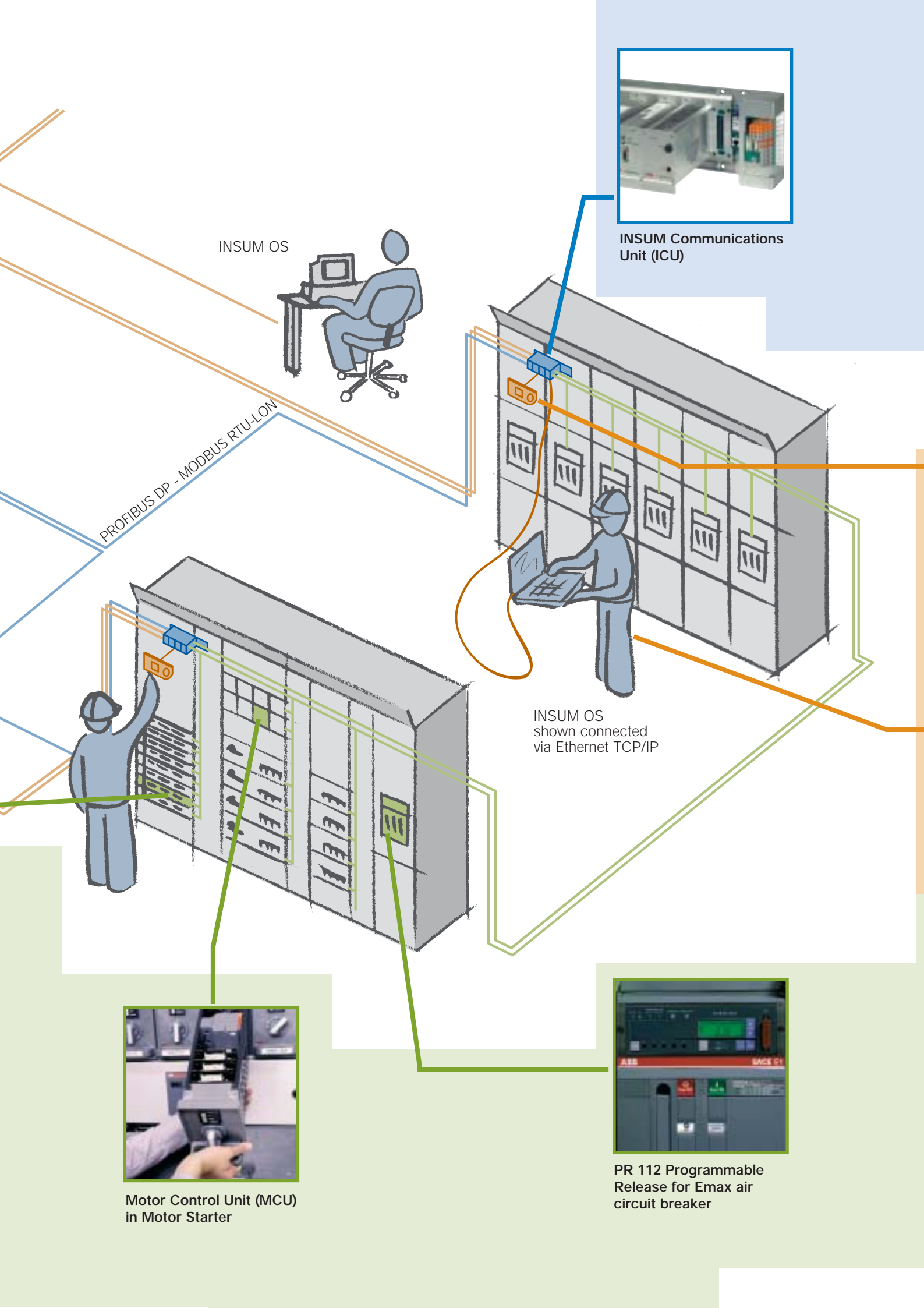

INSUM OS

INSUM Communications Unit (ICU)

PROFIBUS DP - MODBUS RTU-LON

INSUM OS shown connected via Ethernet TCP/IP



Motor Control Unit (MCU) in Motor Starter



PR 112 Programmable Release for Emax air circuit breaker

Communication

- The **INSUM Communications Unit (ICU)** is the switchgear hub for simultaneous communication to higher level control systems via gateway modules. A variety of protocols is available such as: MODBUS RTU, PROFIBUS DP, LON® and Ethernet TCP/IP. Up to 128 field devices distributed over 4 subnets are connected to one ICU.



INSUM MMI
Man Machine Interface

Human System Interface

- **Man Machine Interface (MMI)** is the switchroom operator interface. It enables the operator to configure control and monitor all devices connected to one ICU.
- **INSUM Operator Station (INSUM OS)** is a high-performance Microsoft Windows™ based engineering and maintenance system, which allows connection to multiple ICUs for motor management. It usually connects in parallel to the overall plant-wide Process Control System (PCS).

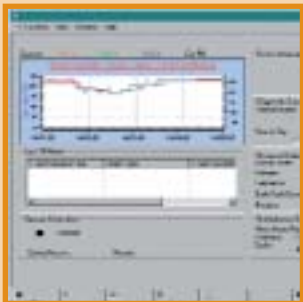

INSUM Operator Station (INSUM OS)

Field Devices

- **Motor Control Unit (MCU)** is an intelligent micro-processor motor protection and control relay, one MCU is used per motor starter.
- The **Programmable Release PR 112** is an intelligent, micro-processor trip unit for ABB air circuit breakers. One PR unit is required per breaker.
- **Integrated Tier Switch (ITS)** is an intelligent switch fuse disconnecter providing fuse measurements, status and reporting.

Table of Contents

Technical Information

Explanations on form, function and features of the system: Here we explain protection functions; control and monitoring with configurable access levels; easy-to-use human machine interfaces; the simplicity of dual-redundant and multi-master communication - all aspects of intelligent low voltage switchgear.

System Overview	4
-----------------	---

Motor Control	8
---------------	---

Motor Protection	9
------------------	---

Reporting and Supervision	14
---------------------------	----

Intelligent Energy Distribution	18
---------------------------------	----

Switchroom Operator Interface	20
-------------------------------	----

INSUM Communications Unit	24
---------------------------	----

INSUM Time Synchronisation	31
----------------------------	----

INSUM Operator Station	33
------------------------	----

MNS Motor Control and Energy Distribution Centers	36
---	----

Industrial IT	38
---------------	----

Technical Data

The section Technical Data describes relevant electrical, mechanical and configuration data for INSUM hardware and software components: MCU1, MCU2, MMI, ICU and INSUM OS. Our products conform with relevant standards and have received approvals. Standards and criteria to which the units have been tested conclude the section.

Technical Data	40
----------------	----

▪ Motor Control Unit	40
----------------------	----

▪ MMI	44
-------	----

▪ INSUM Communications Unit	45
-----------------------------	----

▪ INSUM Operator Station	47
--------------------------	----

Standards and Approvals	48
-------------------------	----

▪ Motor Control Unit	48
----------------------	----

▪ INSUM Communications Unit Devices	50
-------------------------------------	----

From the most basic to the most complex in just two devices

INSUM provides a combination of extensive motor protection, control and monitoring using just two standard microprocessor devices. MCU1 provides motor protection, control and monitoring for the most basic of applications,

whilst MCU2 provides additional functionality, for the most complex and advanced applications. The INSUM system therefore offers a fit-for-purpose solution.



MCU mounted in withdrawable MNS drawer 8E/4. MCU executes control commands from and reports status to remote control systems.

	Non Reversing DOL	Reversing DOL	Non Reversing DOL Latched	Reversing DOL Latched	Non Reversing Star Delta	Reversing Star Delta	Non Reversing Two Speed Actuator	Reversing Two Speed	Auto-Transformer	Soft- Starter
MCU 1	•	•	•							
MCU 2	•	•	•	•	•	•	•	•	•	•

Starter Types

Protecting your assets with all the protection you would ever need!

The motor protection functions safeguard the motor against the unwanted process or mechanical stresses and strains. The protection functions allow pre-sets for "Alarm Levels" "Trip Levels" and "Trip Delays" thus protecting your valuable assets – your mechanical and electrical equipment – and safeguarding your production.

The philosophy is simple to generate alarms when the pre-set alarm level is reached. In this condition the motor will not trip as long as the "Trip Level" is not crossed. If the "Trip Level" is crossed but is within the adjustable "Trip Delay" the motor will not trip. If the "Trip Level" is crossed and the "Trip Delay" expires the motor will trip. In each event messages are generated.

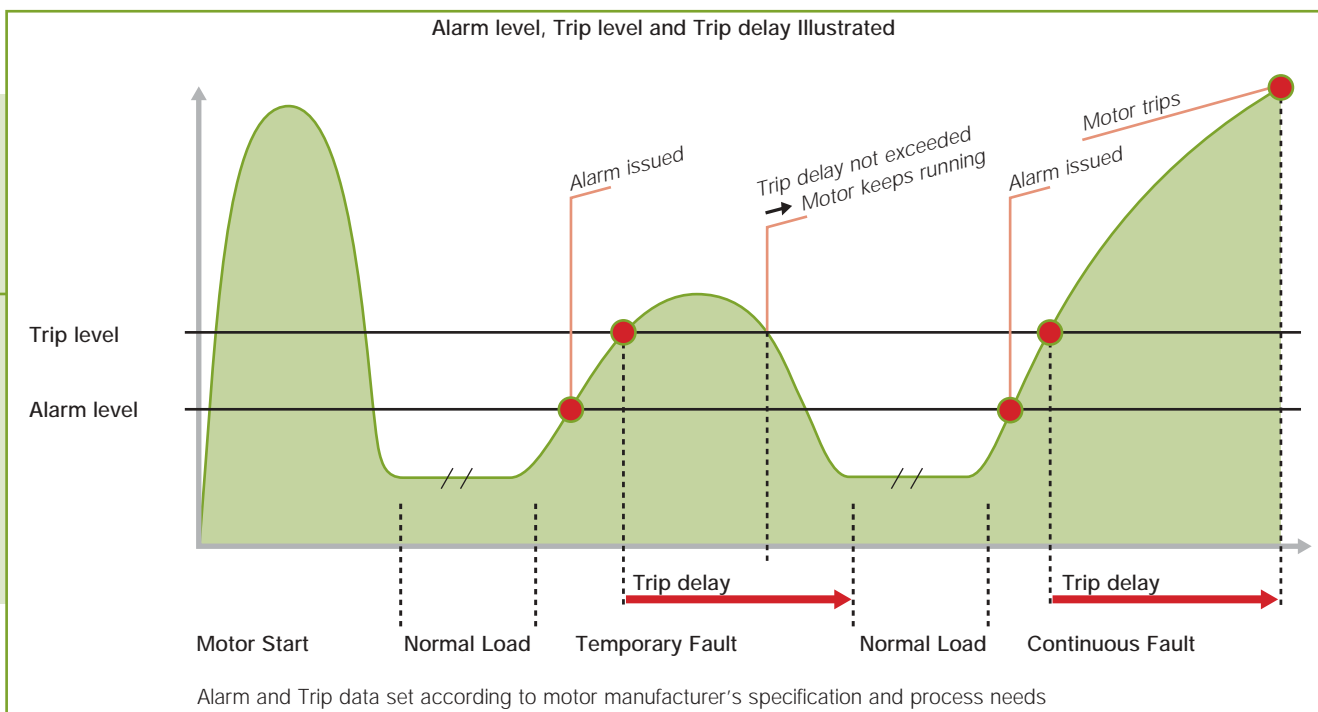

The detailed information on the motor status and configuration is communicated site-wide, providing the plant operator with information enabling preventive actions and educated decision to be made before plant status becomes critical, ensuring plant operators are pro-active in maximizing plant availability with unwanted trips being avoided.

The protection functions are configurable and can be enabled or disabled depending on the requirement.

Additionally protection functions can be set to trip only or alarm only. Protection functions are suppressed during motor start up time and soft start ramp time. The trip-reset modes can also be configured for either of the following:

- Auto Trip Reset
- Remote Trip Reset
- Local Trip Reset
- Remote & Local Trip Reset

Motor Protection

Thermal Overload Protection (TOL) protects the motor against overheating. The motor thermal condition is simulated by calculation both when running and when stopped. The resulting calculation i.e. thermal capacity is stored in the thermal register. The value stored in the thermal register is communicated via the ICU to other devices capable of interpreting the information.

TOL protection is particularly useful during plant start-up where frequent motor starting occurs.

- Functionality of the thermal model according to IEC 947-4-1
- MCU calculates "Time to Trip" and "Time to Reset". Additionally a message "TOL Reset Level Reached" is generated to inform the user of a possibility to reset the trip.
- Automatic restart is also available (MCU2) following a TOL trip, if activated the motor will start automatically when it has cooled down and the trip has reset. The restart will take place in the direction or speed that were active prior to the trip.
- In some process applications it may be beneficial to bypass the TOL protection for short periods. If the "TOL Bypass" command is given after the TOL alarm, the thermal capacity is allowed to rise up to 200 % before tripping. This feature cannot be activated for EEx e applications.

Motor Protection Function	MCU 1	MCU 2	Alarm Level	Trip Level	Trip Delay
TOL Standard	■	■	■	■	
TOL EEx e		■	■	■	



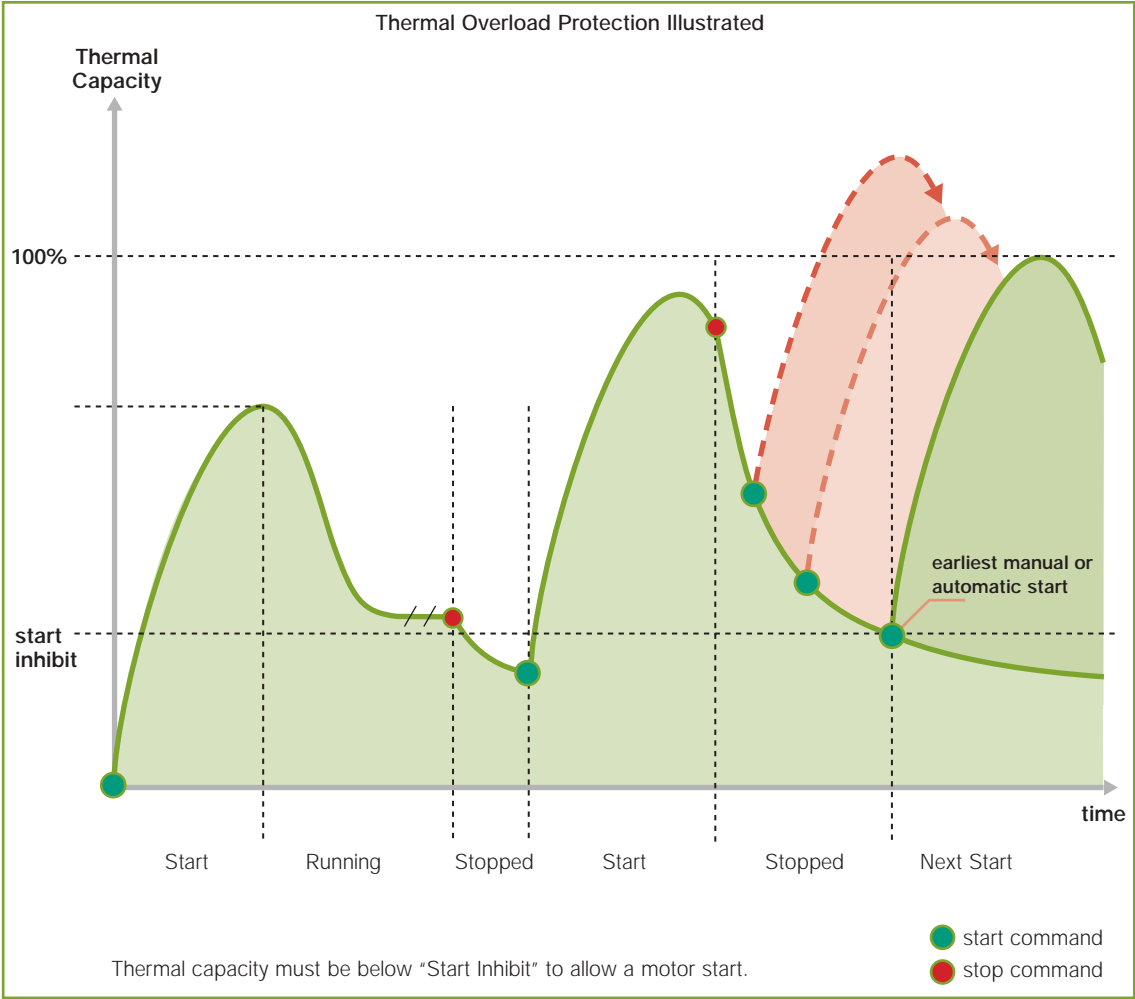

Description

Supports TOL standard. The MCU uses the highest measured phase current for the calculation. The thermal capacity calculation considers actual load, phase unbalance and motor rated load in ambient temperature.

Supports TOL EEx e. Takes into consideration stall/nominal current ratio and the max. temperature allowed by the environment class definition. Data provided by the motor manufacturer is directly entered as setting without additional calculations.

Motor Protection

Motor Protection Function	MCU1	MCU2	Alarm Level	Trip Level	Trip Delay
Phase Loss	■	■	■	■	■
Phase Current Unbalance		■	■	■	■
Stall	■	■	■	■	■
Undervoltage with Automatic Restart		■	■	■	■
Rotation Monitor		■		■	■
Motor Temperature Protection (PTC)		■	■	■	
Earth Fault		■	■	■	■
Start Limitation		■	■	■	
Start Interlock		■	■	■	
Underload	■	■	■	■	■
No Load	■	■	■	■	■
Underload / Underpower Cos ρ		■	■	■	■



Description

Phase loss protection uses the highest and lowest measured phase currents to compare against set levels.

Unbalance can be caused by pitted contacts, faulty motor, loose connections, imbalanced mains. The difference between the minimum and maximum phase currents in % is compared against the set parameters.

Protects against stall, the highest measured phase current to compare against the set parameters, activates only after motor start-up time is complete.

Process specific function allows configuration of MCU restart after main voltage dip. Depending on the voltage dip duration, automatic restart or staggered start can be performed.

Indicates locked rotor condition. Detection is by a sensor providing a digital signal.

Protects against too high a temperature by using PTC sensors. The resistance values are compared against the set levels. Automatic restarting is available if desired. Supervises for open circuit and short circuit conditions.

Detected by residual current transformer.

Limits the number of starts during a time interval. Inhibits motor start when thermal capacity is above the motor startup limitation level. Automatically resets.

Allows the possibility to set a minimum time delay before a new start of motor is possible.

Uses the highest measured phase current, to compare against set parameters. Trip level can be disabled; therefore MCU can be set to alarm only.

Similar to Underload but with different set levels and messages. No load uses the highest measured phase current to compare against the set parameters.

Protects the motor against underload condition based on $\cos \rho$ detection. The $\cos \rho$ value is compared against the set levels. Most accurate method of protecting against cavitation.

More information, better decision making, increased productivity

INSUM continuously supervises the other trip situations as well as keeps track of maintenance data. The below information is available to the user via communication links or at the MMI display. Analog values are given as true rms values.

Messages are generated on status change or when thresholds are exceeded indicating that a certain planned or unplanned system status may be reached. These messages may be alarms or trips generated by the MCU.

Reporting & Supervision Function		MCU 1	MCU 2
Motor Status and Values	Motor Status	■	■
	Phase Currents	■	■
	Analog Output		■
	Calculated Thermal Capacity	■	■
	Time to Trip	■	■
	Time to Reset	■	■
	Phase Voltages		■
	Power Factor		■
	Active Power		■
	Reactive Power		■
	Earth Fault Current		■
	Frequency		■
	General Purpose Digital Input		■
	General Purpose Digital Output		■



All messages are time tagged with the internal time when they occur and the data is reported to the field bus.

Description
Motor status such as On / Off; Open / Closed; Tripped.
Three motor phase currents. Absolute and relative values.
Highest phase current delivered for analog indication, e.g. at the Local Control Panel.
Thermal capacity calculated from motor and environmental parameters.
Estimated time to reach 100% thermal capacity.
Estimated cool-down time at which the thermal capacity of the motor allows a restart.
Three phase voltages. Absolute measured values.
Calculated value.
Active power as absolute value.
Reactive power as absolute value.
Earth fault current measured as absolute value.
Frequency of the electrical power system, absolute value.
Two digital inputs available for read out status of an external device (i.e. remote I/O).
Two digital outputs are available for external control. Can be driven by commands received from the process control system.

Reporting & Supervision Function		MCU1	MCU2
Starter Status and Events	Main Switch in Test Position	■	■
	Miniature Circuit Breaker Trip	■	■
	Feedback Supervision	■	■
	Emergency Stop	■	■
	External Trip	■	■
	Main Switch Trip	■	■
INSUM System Status	Maintenance Data		
	Contactor Switch Cycles	■	■
	Motor Running Hours	■	■
	System Integrity		
	Internal Watchdog	■	■
	Failsafe Functionality	■	■
	Unique option		
	Control Access (CA)	■	■



Description

MCU monitors the main switch, I/O status and phase currents. Current based protection functions are disabled to allow testing. If any phase current is detected, the MCU issues a command to trip the contactor.

MCU executes a contactor trip when Miniature Circuit Breaker Input is activated.

Following receipt of a command signal, the MCU monitors the status of motor and contactor to ensure correct execution. Status is checked by using feedback signals and by current measurement. When enabled will cyclically check the above.

When the Emergency Stop is operated the MCU executes a contactor trip. The release of the Emergency Stop button will not start the motor.

MCU detects an external trip, via unit I/O. When trip input is activated, MCU executes a contactor trip.

Main switch input indicates the status of motor feeder main switch. This input if activated will execute a contactor trip.

Each complete close-open cycle is counted and updated. When the contactor switch cycle limit is exceeded MCU initiates an alarm.

The MCU counts the motor running hours. An alarm is initiated when the predefined operating running hours limit is exceeded.

An internal watchdog relay. In series with the contactor control line voltage, cyclically refreshed by the microprocessor. When no refreshing occurs, the contactor watchdog relay will open.

Supervises the network communication. If a loss of communications is detected the failsafe activates with either one of the following pre-parameterized functions: No Operation, Start Motor Direction 1, Start Motor Direction 2, or Stop Motor. By selecting the correct actions appropriate to the process, total plant shutdown can be avoided.

Control of devices is limited to one host at any time to ensure system integrity. There are up to 16 levels of CA that can be user defined as to whom has the highest authority, usually the PCS. A facility exists that in the event of a failure in the PCS communications link, CA is released to the desired authority ensuring full plant availability.

INSUM – Combining Intelligent Starters, Intelligent Circuit Breakers, and Intelligent Fuse Switches, for that Integrated Solution.

Microprocessor-based components offer an efficient and flexible solution integrating aspects of INSUM motor control and energy distribution management.

As part of one integrated solution protection, control and monitoring of the energy distribution reaches from circuit breakers to fuse switches.

The Intelligent Circuit Breaker

The PR112/PD-L release for the Emax range of air circuit breakers provides communication within the INSUM system. The programmable release with integrated communication and control functions PR112/PD-L allows a wide range of information to be communicated. Breaker status, alarm and maintenance information is communicated upstream where as control commands and configuration settings as well as time synchronization is sent downstream.



Supervision and Protection Function

Breaker Status and Values

- State and position of the circuit breaker
- Phase, neutral and earth currents

Protection

- Function: Overload (L). Selective short circuit (S). Instantaneous short circuit (I). Earth fault (G). Over-temperature (T)
- Alarms for protection timing of L, S and G
- Alarms for protection trip of L, S, I, G and T
- Overload and excessive temperature
- Memorization of fault currents

Maintenance Data

- Alarm for contact wear
- Contact wear
- Number of total and manual operations
- Number of total trips per protection functions (L, S, I, G and T)

The Intelligent Tier Switch (ITS)

Supervision Function

- Fuse status, supervises fuses individually and reports status.
- Temperature, ITS-E supports 2 NTC temperature sensors.
- AC current per phase. rms value is calculated based on the amplitude of the phase current. % of fuse rating or absolute value.
- DC current, % of fuse rating or absolute value.
- Line voltage. rms value is calculated once per second based on the measured amplitude of the phase voltages. Balanced three-phase system is assumed.
- Active power. Based on measured voltage, current and phase angle.
- Power factor. Based on calculated active power and volt-amperes.

The Intelligent Tier Switch (ITS) is a SlimLine switch fuse disconnecter with integrated sensors and a communications interface for online status supervision. Temperature and current limits can be set with adjustable alarm delays. The device issues an alarm when the temperature exceeds the limit or when a fuse blows. Each fuse status is indicated with its own red LED. A green LED indicates normal operation and communications status.

The ITS is available in four sizes up to 630 A.



Data and Control at the Operator's Fingertips – The INSUM MMI

Operator interface to the intelligent MNS System in the switchroom is via the INSUM MMI (Man Machine Interface). It displays measured values and status information of all (up to 128) field devices connected to a particular INSUM Communications Unit (ICU): motor control units, circuit breaker programmable release and fuse switches, as well as communication devices.

The context sensitive function keys allow for the control of these devices and for configuring their functions by defining their respective parameters. Access to the menu and functions can be defined by using an electronic data key, the INSUM Data Key, with configurable privileges.

All information is sorted in menus and displayed on the MMIs 6-line 21 character LCD. The encoder wheel provides easy navigation through lists of data, parameters, alarms and trips, via clearly structured menus and sub-menus. The ENTER, ESCAPE and HOME key assists the navigation through the different menus resulting in a very friendly, easy to use interface.

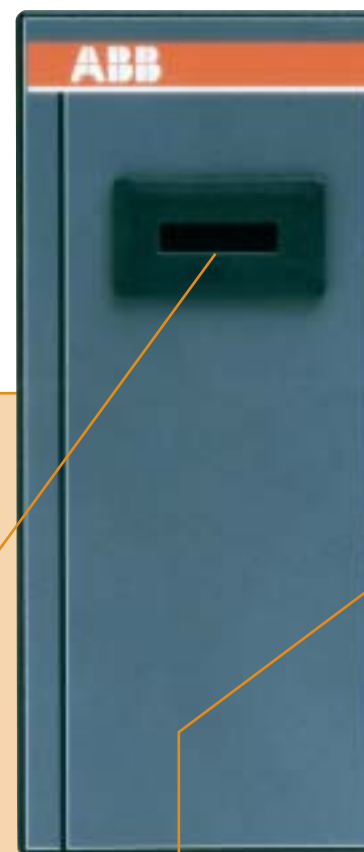

Slot for INSUM Data Key

LCD Display

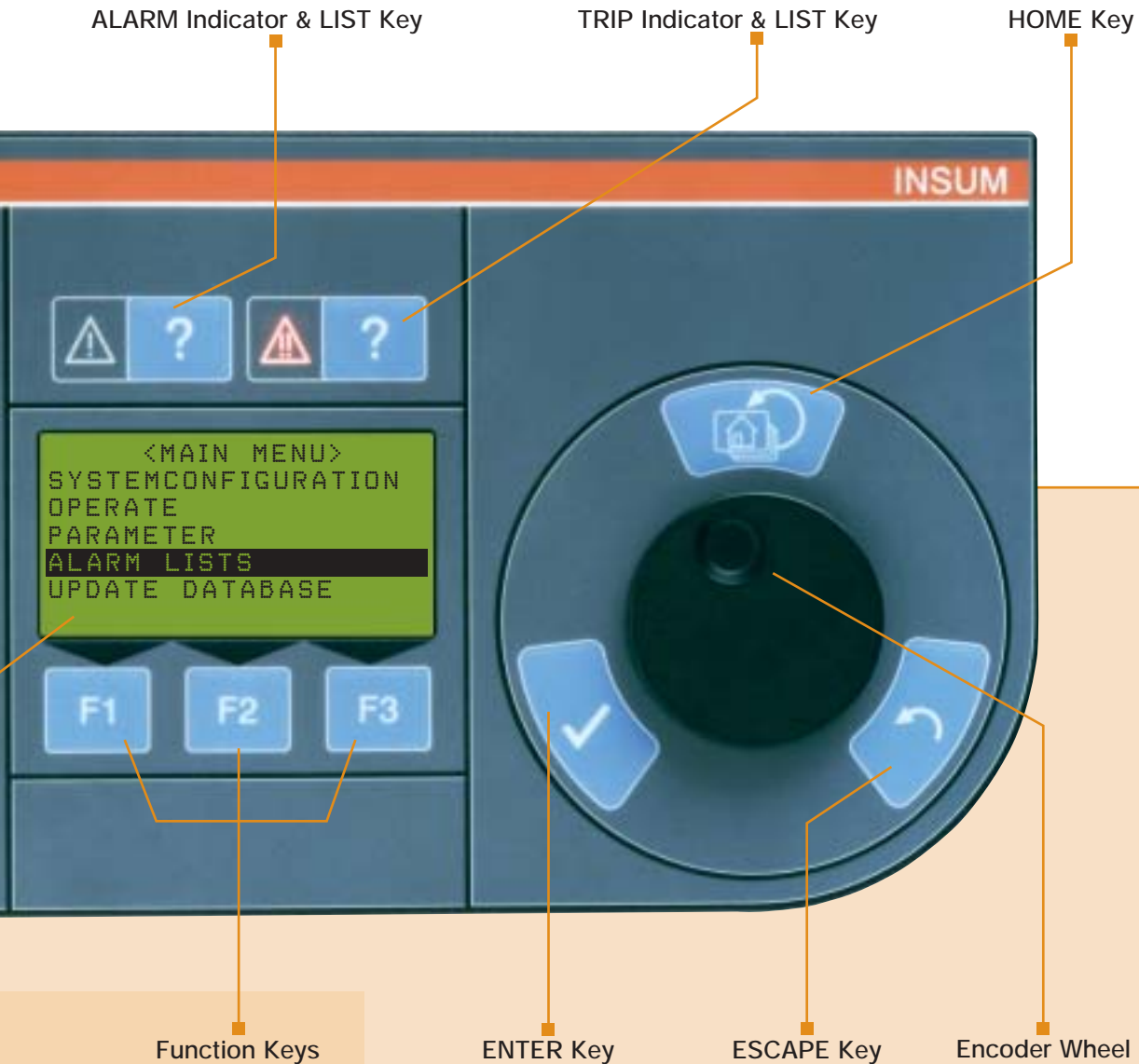

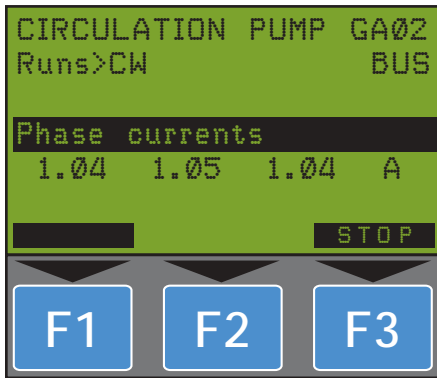

Operation and Monitoring

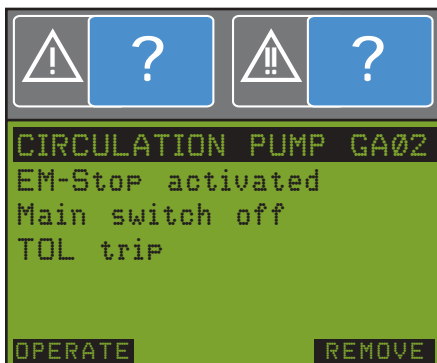

Alarms and Trips

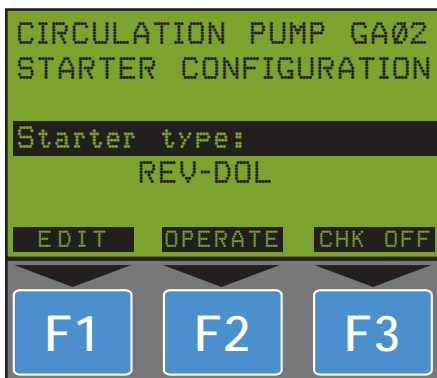

Motor and Feeder Configuration

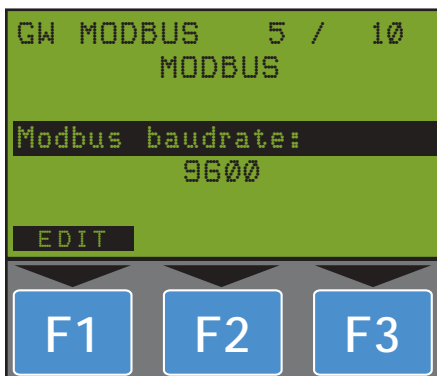

System Setup

Monitoring and Control

Motors and Feeders may be controlled and monitored via the MMI. Only the menu items applicable to the appropriate function will appear ensuring best possible user guidance. To avoid unintentional depressing of the keys any message that is sent via the field bus always requires the key to be depressed twice. "Select before operate" is the philosophy. Status, measured and maintenance data is also monitored and displayed.

Alarms and Trips

In the event of a system, process or maintenance alarm or trip, messages are sent via the ICU to the Process Control System and the MMI. LED's signal the alarm or trip condition where dedicated keys guide the user directly to the alarm or trip lists. Alarms and trips are listed in time order. The encoder wheel allows the operator to scroll and navigate directly to detail displays.

Motor and Feeder Configuration

The INSUM MMI guides the operator through the system configuration with user-friendly text and prompts. Parameters are listed in sub-menus according to their main function groups. The MMI only allows the selection of values that are within the correct configuration range.

System setup

The complete configuration of INSUM devices connected to the INSUM communication unit and subnets can be programmed via the MMI, for example installing devices and allocating their address. Proper device communication can also be verified via the MMI.

Access Privileges

For plants that require different access levels for security reasons, user profiles can be defined and stored in the INSUM Data Key. Thus it can be decided what authority is given to plant operators, instrument electrical technicians or other user definable groups. Reading of values is allowed for all user levels, with access privileges assigned to:

- particular plant sections (process groups),
- several device types,
- single protection functions,
- single parameters and any kind of operating activities,
- reset of alarms and trips.

The MMI grants access rights according to data stored in the INSUM Data Key, and rejects invalid keys, e.g. keys allocated to a different process group.

INSUM Data Keys can be ordered as standard types or configured particularly to the needs of a single plant.

Integration into MNS Low Voltage Switchgear

The MMI is the switchroom window to the low voltage switchgear. Providing ease of operation in a convenient location only one MMI is required for up to 128 devices.



Collecting, filtering and distributing the right information to the right people - site-wide!

The INSUM Communications Unit (ICU) is the switchgear communications hub for up to 128 devices consisting of MCUs, PR 112 and ITS fuse switches. It directs and localizes bus communication therefore optimizing network load and response time. The ICU can maintain up to three simultaneous connections to higher-level control systems, making dual-redundant configurations and multi-master communications an

integral part of the system design. The modular, plug-in design allows configurations scalable to application needs. All connections are located on one side of the ICU for simple and reliable wiring. The operator interface to all field devices in the switch room (MMI) connects to the ICU. These attributes lead to a cost-effective and very flexible system design.

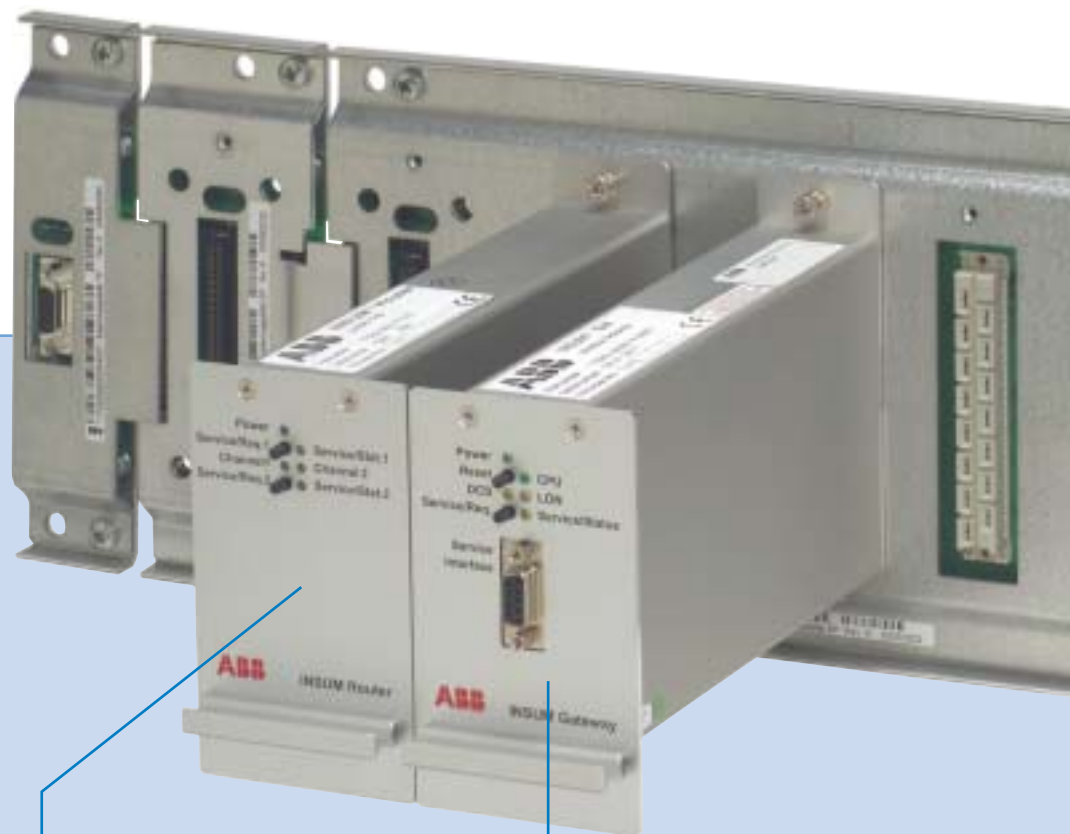

■ Router

■ Gateway

Communications Philosophies

Most protocols operate in master-slave mode, where the master controls communication on the bus and cyclically exchanges information with every slave device (bus polling).

In most applications the PCS assumes the role of the master.

Peer-to-peer or master-master communications allow exchange of data between devices on an equal rights basis. Field devices and control systems communicate event-driven, leading to shorter response times. INSUM utilizes this form of communication throughout.

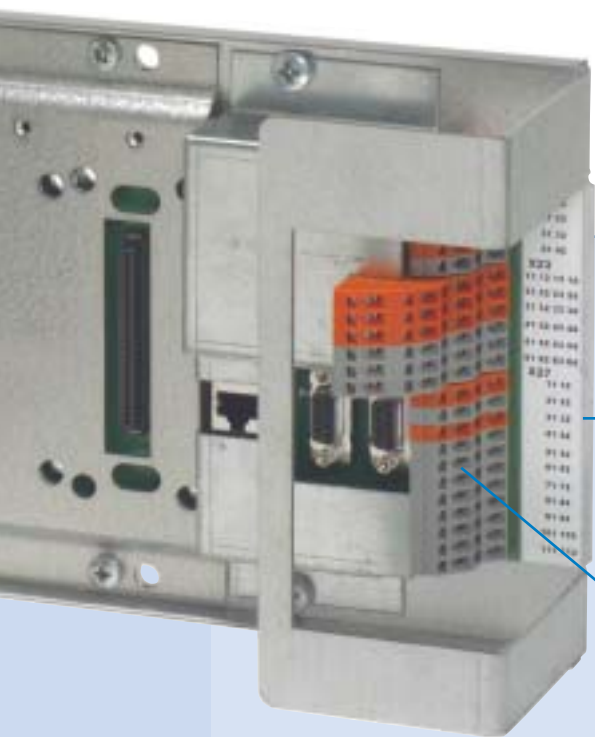

■ Backplane

■ All terminals and filtering located on one side of the ICU

Fast and Reliable - Peer-to-peer Communications at the Field Level

The LonTalk® open field bus is used for data transmission within the INSUM system. LonTalk communicates peer-to-peer and event-driven. In contrast to master-slave algorithms, the bandwidth of the transmission medium can be used very efficiently with this method.

In peer-to-peer communication each node – field device or control system – exchanges data directly with each other node on an equal-rights basis. A collision avoidance method named Carrier Sense Multiple Access (CSMA), called predictive persistent is used to minimize the possibility of collisions. In CSMA, a bus node makes sure before it transmits data that other bus nodes do not occupy the transmission medium. This minimizes the risk that two bus nodes may access the “available” bus simultaneously.

In event-driven communication data is transmitted if it has changed. Binary data is sent when its value changes, analog data when the change exceeds a preset dead band. Additionally, INSUM devices cyclically schedule all data for update irrespective of change. The system therefore employs both event-driven and cyclical updating techniques, enhancing both the security and the reliability of the transmitted data.

The schedules facilitate heartbeats, which are used to control integrity of data links and hardware in two ways: (1) Field devices issue heartbeat messages in conjunction with status data, which is checked in the ICU. Alarms are generated when heartbeat messages are discontinued; (2) Fail-safe functionality relies on heartbeats and sets the motor application into a defined state when communications to higher-level control systems is jeopardized.

Gateway: Communication to control systems

Backplane: ICU backbone for internal communication

Router: Connection to field devices via subnets.

Connectivity and Communication

The backplane is the core of the ICU and hosts Gateways, Routers and the optional power supply. The LON main bus communicates at 1250 kbps, providing sufficient bandwidth for handling traffic to and from the subnets, which communicate at 78 kbps. Up to four subnets, two per Router, are supported by one backplane. Up to 32 field devices: MCUs, PR112's and ITS fuse switches, are located on one subnet.

Utilizing multiple subnets with peer-to-peer communication reduces access time to individual devices and optimizes the network load by localizing traffic. The system response time, consisting of a command received at the ICU,

transmission to the field device, command execution and response back for collection is typically less than 200 ms.

Gateways provide connection and data filters for communication of essential information to higher level systems. With four Gateways connectable to one ICU the INSUM system offers multi-master capabilities as an integral part of the design. Two ICUs configured in one system paired with peer-to-peer communications at the field level provide an inherently simple method for dual-redundant communications down to the field device.

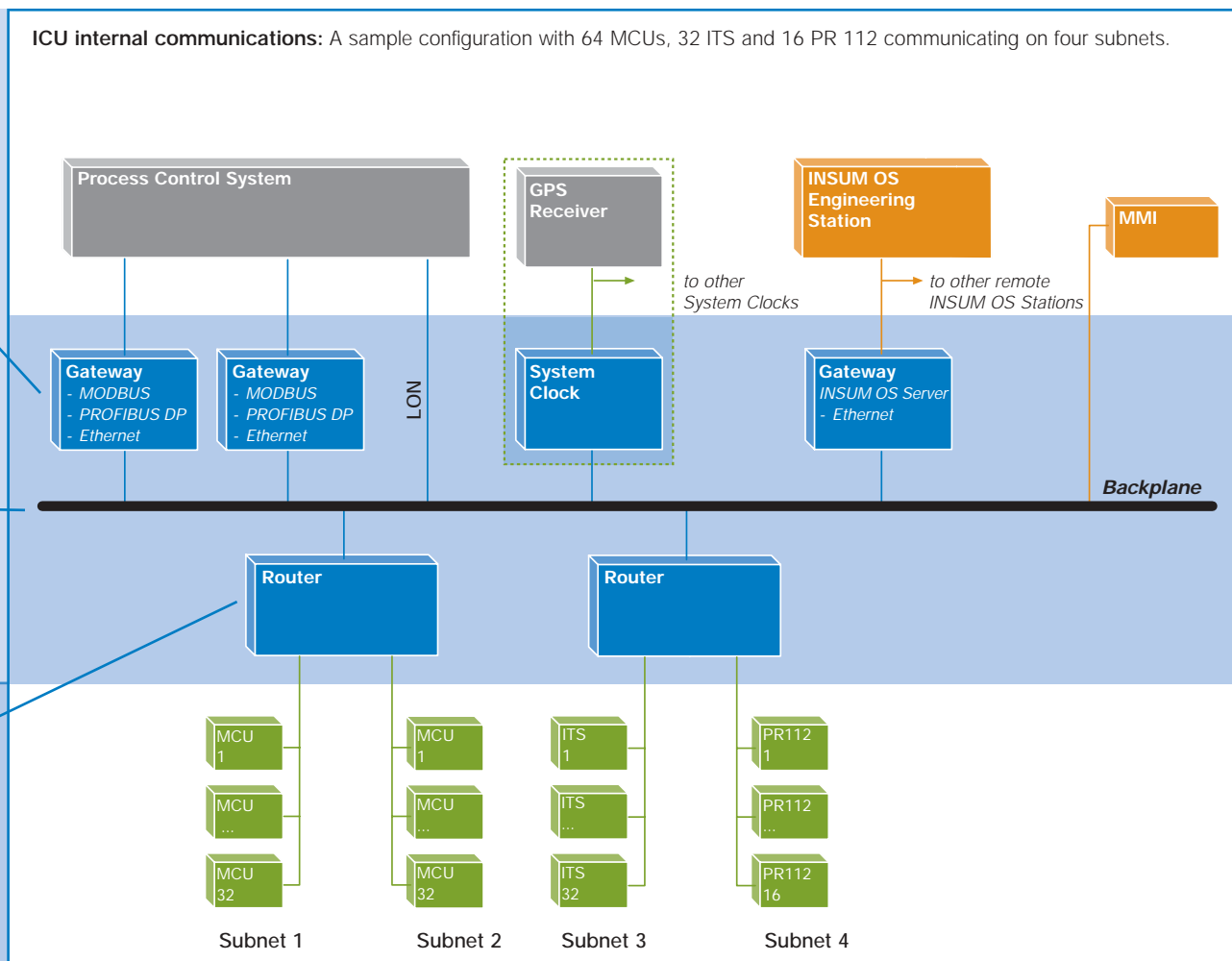

Communication Protocols

Gateways for different protocols can operate simultaneously on one backplane. Protocols are implemented according to the definitions provided by the respective manufacturer or governing organization. Interfaces to virtually any manufacturer's control system have already been realized with these protocols and are in operation today.

Simple Windows™-based tools allow data and communication configuration. Gateway configuration allows selection of relevant data optimizing network traffic and ensuring that the right information reaches the right people at the right time. Pre-configured data mapping is available for MODBUS RTU and PROFIBUS DP protocols.

	Modbus RTU	PROFIBUS DP	Ethernet TCP/IP	LON
Max. communication speed	38.4 kbps	1.5 Mbps	10 Mbps	1.25 Mbps
Master-slave	■	■		
Peer-to-peer			■	■

- **PROFIBUS DP and MODBUS RTU**

The physical connection is possible in point-to-point or multi-drop configuration. The INSUM system is typically configured in slave mode responding to queries from the PCS. On PROFIBUS DP one ICU supports up to 96 field devices utilizing two Gateways. MODBUS RTU data maps can be freely configured to PCS needs.

- **LON**

Master stations communicating via LonTalk are directly connected to the main bus without a Gateway. Individual data mapping is configured at the PCS.

- **Ethernet TCP/IP**

Using standard Ethernet components and the TCP/IP protocol the Gateway can be integrated into an existing network infrastructure. Data can be transferred to the PCS or the INSUM OS.

Information and Commands available on Communications Links

A selection of data available for transmission to and from higher level control systems. Complete lists are available in the appropriate device manuals and depend on the starter types used.

	MCU	PR 112 / PD-L	ITS
Status	Motor Running Motor Stopped Motor Alarm Motor Tripped Staggered Start Executed Main Switch Off Test Position Local/Bus Control General Purpose In-/Output	CB Open CB Closed CB Isolated CB Springs Charged/Discharged Local Operation Warning Trip	Fuse Blown (L1,2,3) Switch Closed/Connected Overcurrent (L1,2,3) Module Alarm Module Tripped
System	Lifesign Failsafe	Lifesign	Lifesign
Control	Start Stop Group Start/ Stop Reset TOL Bypass	CB Open CB Close Trip Reset	Not applicable
Measuring Values	Phase Current L1,2,3 (%A) Earthfault Current Voltage (V1,2,3) Frequency Active/Reactive Power Power Factor Apparent Power Thermal Image Time to Trip Time to Reset Maintenance Data	Phase Current L1,2,3 (%A) Current at Trip L1,2,3 (%A) Earthfault Current Earthfault Current at Trip Neutral Current Neutral Current at Trip Maintenance Data	Phase Current L1,2,3 (%A) Earthfault Current Voltage (V1,2,3) Frequency Active/Reactive Power Power Factor Module Temperature

	MCU	PR 112 / PD-L	ITS
Alarms / Alarms with Trip	TOL Alarm/Trip Startup Inhibit Alarm/Trip Phase Loss Alarm/Trip (L1,2,3) Underload Alarm/Trip No-load Alarm/Trip Underload Cos Phi Alarm/Trip Stall Alarm/Trip Earthfault Alarm/Trip Phase Unbalance Alarm/Trip Rotation Alarm/Trip Torque Trip PTC Temperature Alarm/Trip Undervoltage Alarm/Trip Autoreclosure Alarm Start Limitation Alarm/Trip Start Interlock Alarm/Trip Emergency Stop Drawer Location Alarm Feedback Alarm Maintenance Alarm	CB Undefined CB Trip LC1 Opened LC2 Opened Unbalanced Phases Harmonic Distortion Contact Wear Pre-alarm Contact Wear Alarm Prot. L Pre-Alarm/Alarm/Trip Prot. S Alarm/Trip Prot. I Trip Prot. G Alarm/Trip Prot. T Pre-Alarm/Alarm/Trip	Fuse Blown (L1,2,3) Overcurrent (L1,2,3) Module Temperature Alarm/Trip

INSUM System Clock

Plant Wide DCS Reporting may require INSUM to be synchronized to ensure INSUM device times are the same across the whole plant. This is achieved via the System Clock. The cyclic time information is sent via the INSUM

internal LON network to each INSUM device connected to the ICU. This enables INSUM to provide events as time stamped messages via the Ethernet Gateway, when received from the field devices.

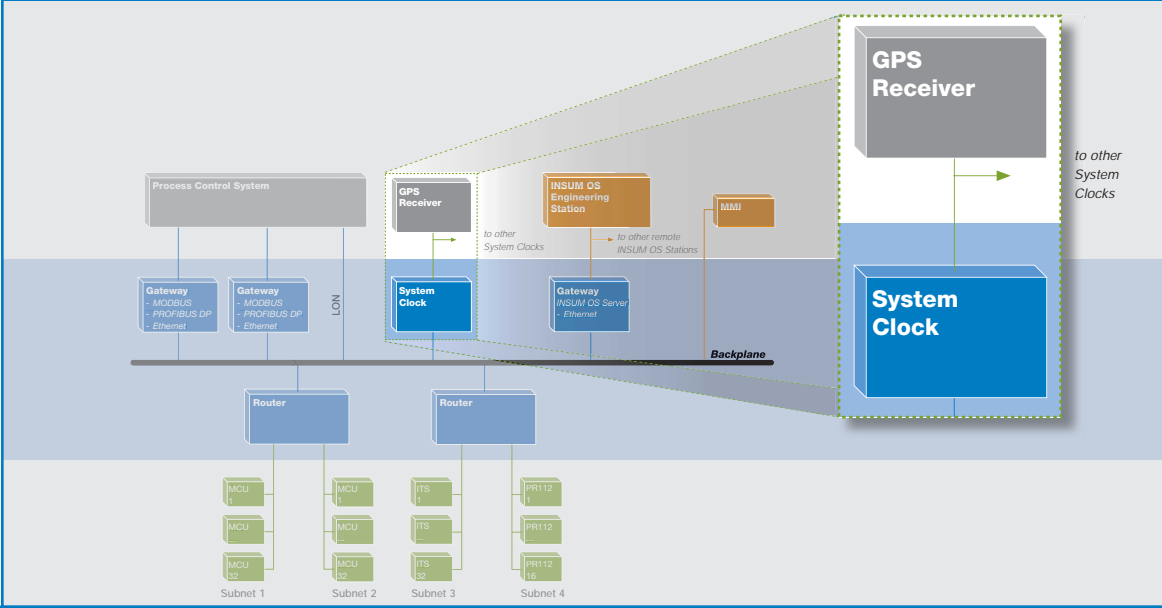

The System Clock modules can operate either Stand Alone or with GPS Receiver. This depends on the type of synchronization information required. The respective modes are called Slave or Master and can be configured via the MMI together with other Clock settings.

Stand Alone Mode

For standard requirements on time accuracy, one System Clock in the switchgear can run in Master Mode.

In Master Mode the time signal is generated by use of its internal clock. This time signal is distributed via RS422 to enable other System Clocks in Slave Mode to utilize the same time signal. The received time is broadcasted to all connected subnets of the ICU.

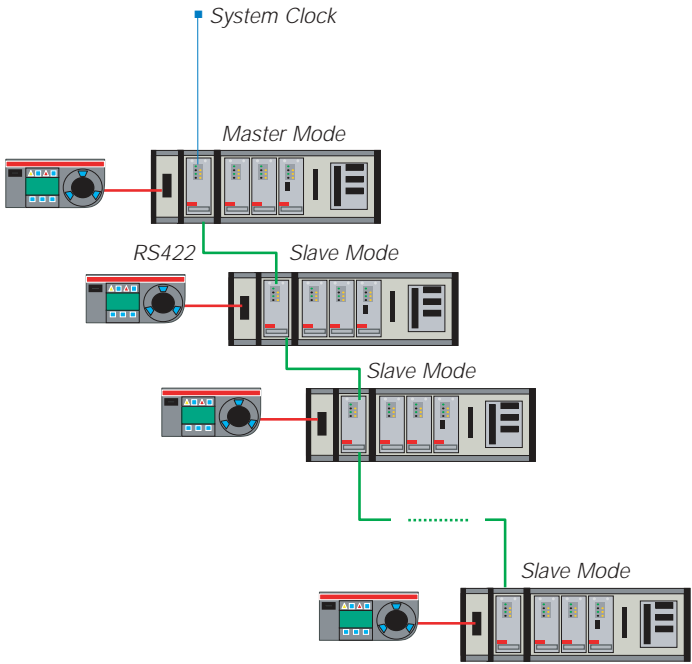

GPS Mode

To ensure a high accuracy of time the System Clock can be configured as a slave processing the time information from a GPS Receiver with serial interface.

Utilizing this mode requires an additional hardware (Hopf GPS System 6870), which provides the needed time information. The time base is synchronized by a global installed satellite system (GPS). The processed signal is broadcasted via connected System Clocks (in Slave Mode) to the subnets of each ICU.

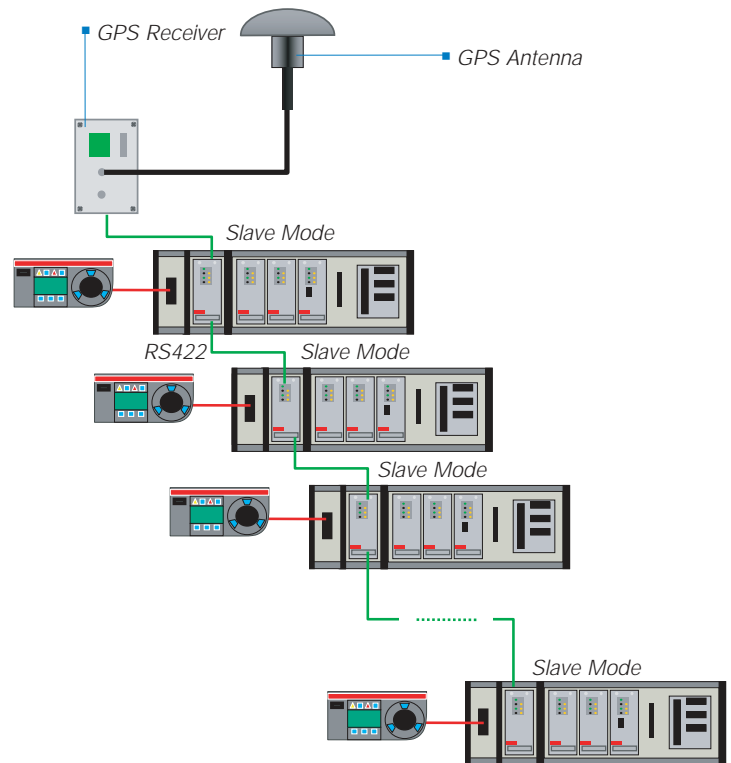

Global Positioning System (GPS)

The satellite Global Positioning System (GPS) distributes precise time, frequency and position worldwide. At a height of about 20,000 km satellites circle around the earth on different orbits.

An atomic clock runs in every satellite whose time is constantly transmitted together with the orbital data. The GPS Receiver records the data of up to 6 satellites and uses this information to calculate its position and time.

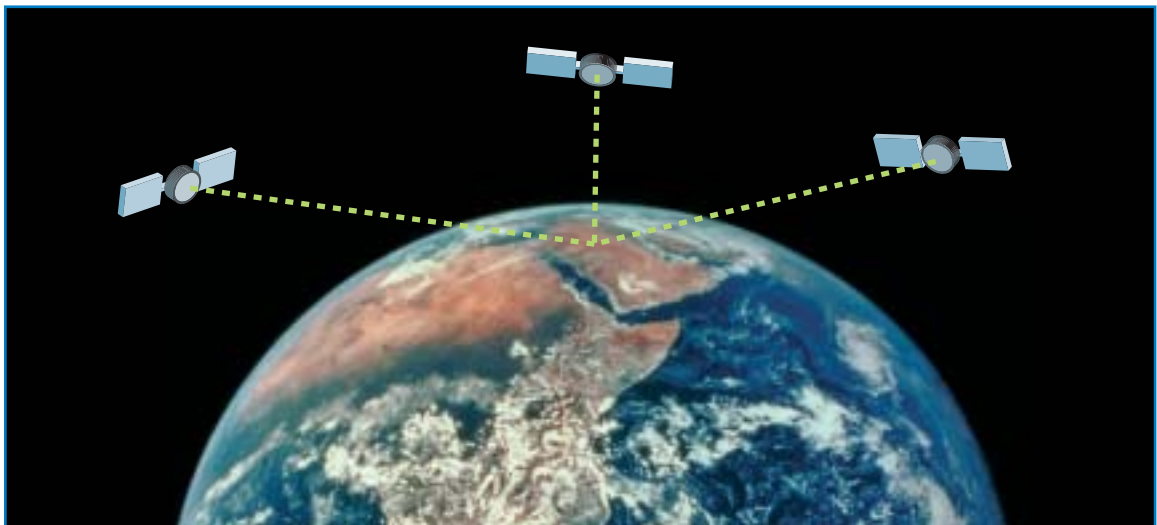

Your plant switchrooms accessible on your office desk just a few clicks away.

INSUM Operator Station (INSUM OS) is a Windows-based, user friendly, high performance engineering and maintenance system. It constitutes a powerful configuration tool for both control and monitoring of the INSUM system

with seamless integration through a Client/Server architecture utilizing existing standard Ethernet network infrastructure. INSUM OS connects in parallel to the PCS.



Function and Operation

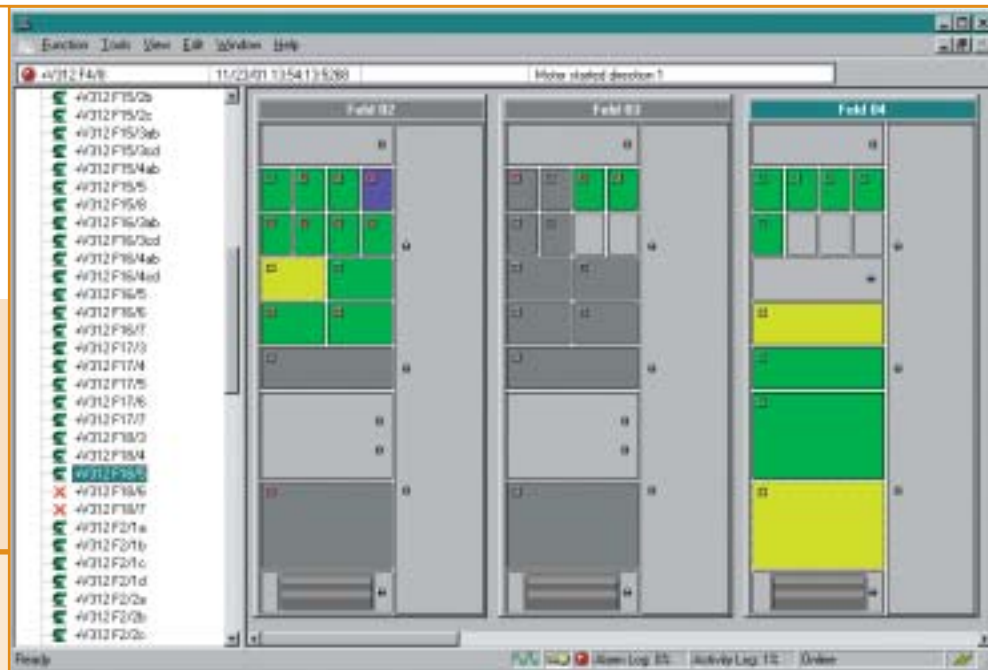

Switchboard / MCC overview: Graphical General Arrangement of the switchboard interface. It provides the user with the most advanced information and easy recognition of motor starter devices and their location. Device tags are provided for identification, with selectable colours for offline, running, stopped, tripped and alarm.

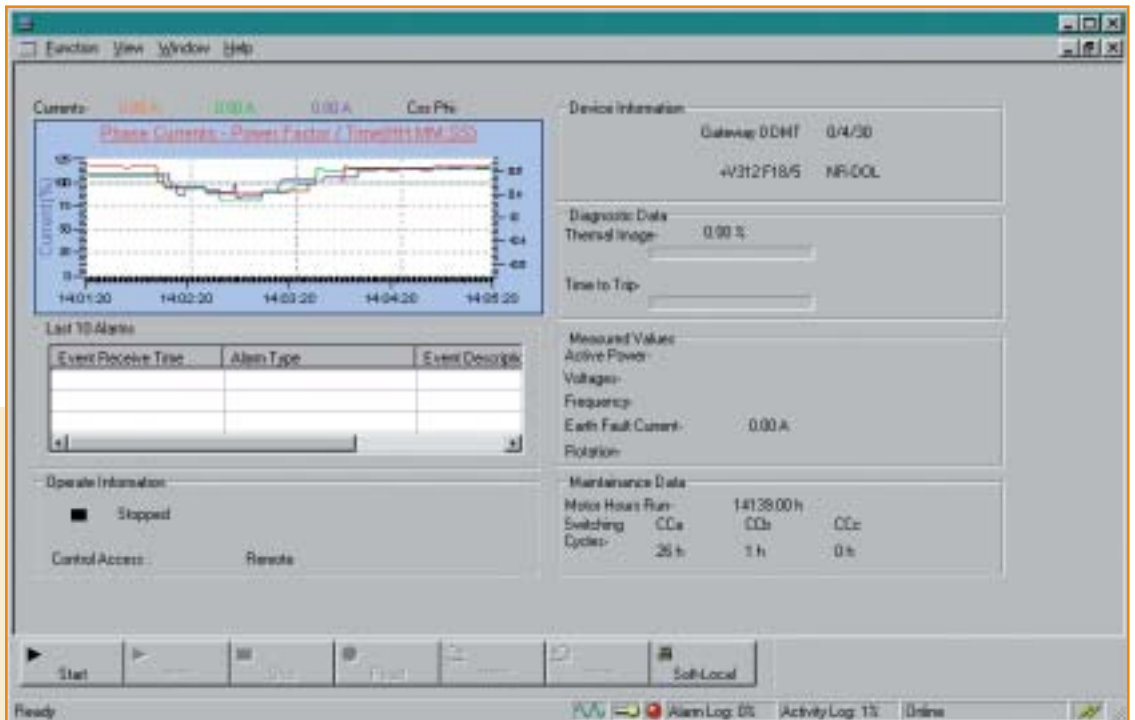

Device Operation: This window provides status and measurement information, short term trend of current measurement and last ten device alarms.

The screenshot shows the 'Event Log' window. It contains a table with the following data:

Location Identifier	Event Receive Time	Receive Time	Acknowledged	Alarm Type	Event Description
+V312 F4/B	11/23/01 13:54:13:268				Motor started direction 1
+V312 F4/B	11/23/01 13:54:13	Yes	No		Motor started direction 1
+V312 F4/A	11/23/01 13:54:00	Yes	No		Motor started direction 1
+V312 F2/3ab	11/23/01 13:53:49	Yes	No		Motor started direction 1
+V312 F2/3cd	11/23/01 13:53:38	Yes	No		Motor stopped
+V312 F2/3cd	11/23/01 13:53:34	Yes	No		All alarms and trips cleared
+V312 F2/3cd	11/23/01 13:53:32	Yes	No		All alarms and trips cleared
+V312 F2/3cd	11/23/01 13:53:31	Yes	No	Going Alarm	Failure activated
Internal Alarm	11/23/01 13:52:05	Yes	No		OS started

Event Log: Each event is recorded along with the time tag and other associated information such as 'Alarm Type' and 'Event Description', making it possible to filter the alarms. The user can 'Acknowledge' the alarm from the Operator Station by simply selecting the alarm with the mouse and then 'right clicking' the alarm.

System Architecture

Function	Description	
Components	Client	The user interface software based on Windows.
	Server	Based on dedicated hardware (INSUM Ethernet Gateway) monitors the INSUM system and simultaneously updates multiple clients event driven.
	Communication	Based on TCP/IP the communication can utilize standard network components and existing infrastructure.
Features	Multiple Client / Multiple Server	Multiple clients and servers are connected to the same network. Each client communicates to a server independent of other clients.
	Mobile Client	Client typically installed on a portable PC with a direct connection port in the switchgear room for immediate and local access to the devices for analysis and configuration.
	Device Management	Device configuration tool providing an optimized user interface for identification, parametering, status monitoring and configuration.
	Offline/Online configuration	Offline preparation of single device parameters. Online parametering of single or grouped devices.
	Tag logging and reporting function	Alarm log stores more than 10,000 alarms and events, with time stamp, alarm type and description. The latest unacknowledged alarm is displayed at the top of the list for immediate action. Shows latest 10 alarms and events on a device detail screen.
	Control Access Utility	Setup tool for Control Access facilities of INSUM.



A global product for a global age

Manufactured in 29 countries worldwide, and with over 900,000 vertical tiers in operation in all types of applications, from Offshore Oil and Gas to Building Services, MNS is truly a global product.

- Modular framework.
- Rear mounted, horizontal busbars permitting 2 electrically independent busbars in the same board.

- Front Access
- Duplex arrangements utilizing common busbars
- Compact design enables high stacking density, which gives a reduced footprint
- Certified busbars up to 6300 A
- Ingress protection up to IP 54
- Forms of segregation up to Form 4
- Module types for different applications in fixed, plug-in or withdrawable pattern.
- Extensive testing and certification
- Maintenance free busbar clamps
- Lloyds approved for Marine applications

Applications

Power Plants
Oil & Gas
Petrochemical
Pharmaceutical
Pulp & Paper
Mining
Water Treatment
Waste Management
Steel Industry
Food Industry
Automotive Industry
Public Buildings
Public Transport
Airports
Infrastructure Projects



Function	Description	
Electrical Ratings	Current	Up to 6300 A AC
	Voltage	Up to 690 V AC
	Frequency	50 Hz - 60 Hz
	Motor starter sizes	Up to 355 kW
	Starter Co-ordination	Type 2, IEC 60947-4-1
Protection Characteristics	Insulation voltage	1000 V AC
	Short circuit current	30 kA - 100 kA (1 sec)
	Protection class	IP 20 - IP 54
	Internal separation	Up to Form 4
	Vibration	0.7 g / 100 Hz
	Shock	15 g
Standards and Approvals	Standards	IEC 60439-1
	Arc-resistance	IEC 61641



IndustrialIT – Information at a glance

The physical installation of system devices, such as the DCS and the associated Switch-gear / MCC's, has been well established over many years. The difficult part is collecting the information of the installation, operation, and the maintenance of each component – bearing in mind this information has to be kept up to date. The Industrial IT solution is based on using a common system architecture, which will enable productivity to increase, by maximizing plant / asset availability. At the same time help and guidance is provided wherever clarification of the plant process is needed.

Aspect Object

Industrial IT from ABB changes all this to an enterprise-wide architecture providing plant-wide integration of information. Real objects are transformed to the ABB Aspect Object™ technology. The list of device characteristics (the aspects) begins with complete documentation, drawings and instructions. Depending on the product, additional aspects may include configuration, maintenance tools, communication protocols and faceplates.

IndustrialIT Enabled

In the same way as PC users benefit from the drivers, fonts and utilities supplied with a new peripheral product, Industrial IT Enabled™ technologies are bundled with standard sets of characteristics. Products are tested and certified at a certain level of integration.

The ABB Aspect Integrator Platform™ allows grouping of these certified devices and their associated Aspect Objects, in easy-to-navigate structures, tailored to the needs of operations, maintenance, and management personnel. Realtime interaction between Industrial IT Enabled products means configuration, operation, and evaluation of each takes place within the context of its larger system. The results: Fast installation, logical navigation, and more intuitive enterprise management.

- Monitor, control, optimize, and maintain from one powerful, open platform
- Evaluate and deploy plant components just like browsing the files on a PC
- Access exact documentation and information, from the components employed within the plant

Protect IT - MNS Motor Management INSUM certified according to Industrial IT requirements allows the user the advantages of fieldbus communication together with the Industrial IT architecture in an optimized way. The integrated system enables access to documentation when it is needed, immediate overview re-switchgear status and preparation of any required maintenance or other action.

Industrial^{IT} case book

Through ABB's Aspect Integrator Platform or the ABB Aspect Object Viewer™ hundreds of "information enabled" products are arranged in a dynamic hierarchy that lets the engineer zoom in to quickly find the right information for any device. For example if a faulty component (e.g. a motor) was identified, Industrial IT will support and guide the engineer to initiate maintenance work.

- Open Alarm List to verify process status and alarm history of the component
- Click the icon for Plant Component to open the menu of available asset information
- Open Product Information to verify model and serial number, purchase and cost information
- Review Maintenance Manual and Instruction for recommended service interval
- Initiate a preventive maintenance work order and file directly with Aspect Object



Motor Control Unit

Mechanical Data

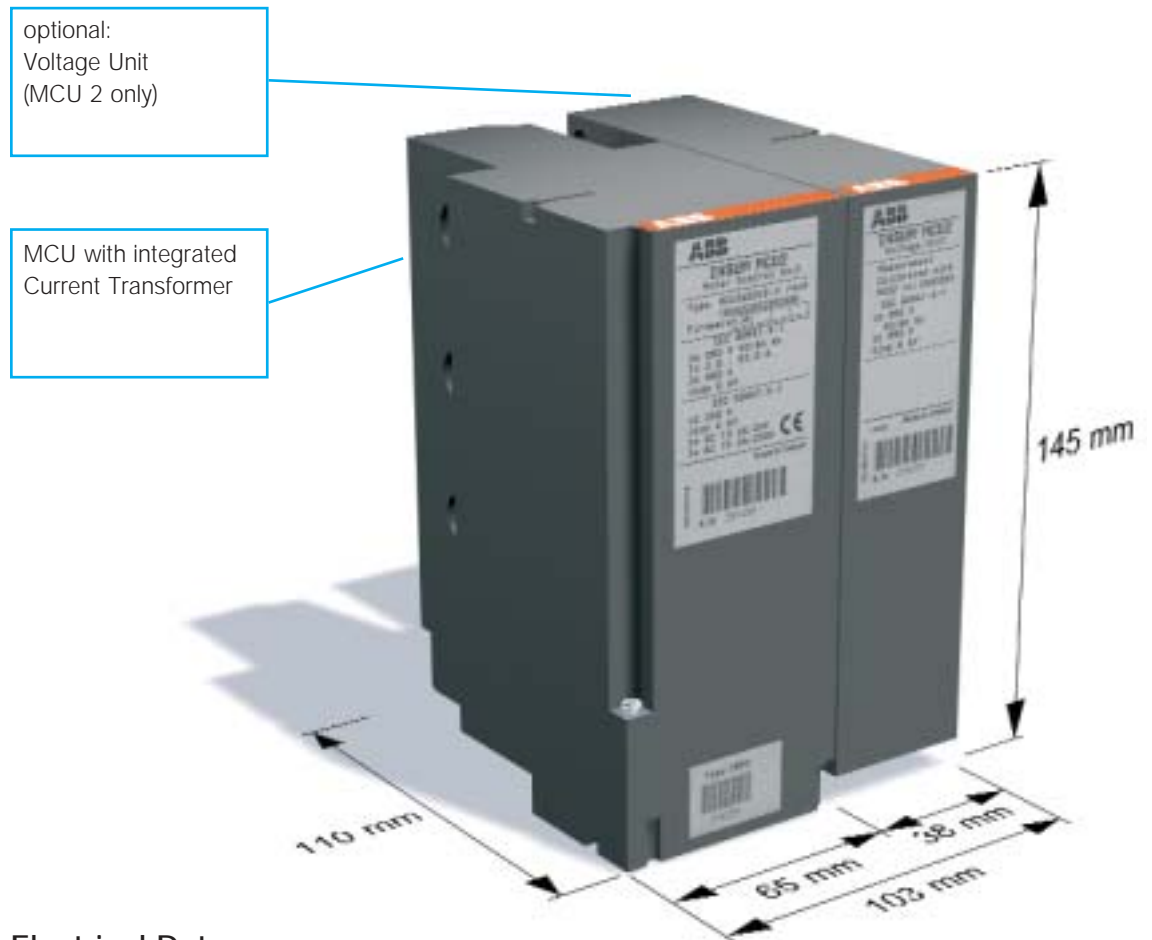

Electrical Data

Main Circuit

Rated Operation Voltage (U_e)	230 ... 690 V
Rated Impulse Withstand Voltage (U_{imp})	6 kV
Rated Current (I_e)	0.1 ... 3.2 A or 2.0 ... 63 A
Rated Frequency	50 / 60 Hz

Control Circuit

Rated Operation Voltage (U_e)	24 V DC or 230 V AC
Rated Current (I_e)	2 A
Rated Frequency	50 / 60 Hz

Auxiliary Supply Voltage 1 (U_{AUX1})

Supply Voltage (U_e)	24 V DC
Voltage Range	+19 ... +33 V DC

Auxiliary Supply Voltage 2 (U_{AUX2})

Supply Voltage (U_e)	220 / 230 V AC
Voltage Range (U_B)	$0.85 \times U_{e \min} \dots 1.1 \times U_{e \max}$
Insulation Voltage (U_i)	250 V AC
Frequency	50 / 60 Hz

Power Consumption

Typical	4.7 W
Maximum (MCU1)	7.2 W
Maximum (MCU2)	8.2 W

Digital Input

Closed Contact Current (peak)	2.5 ... 10 mA
Open Contact Current (peak)	0 ... 0.9 mA

LED Output

Output Voltage	14 ... 25 V DC
Nominal Current (short circuit protected)	20 ... 32 mA

Environmental Conditions

Storage Temperature	-25 to +85 °C
Operation Temperature	-5 to +55 °C
Degree of Protection	IP 20
MTBF	12 years

Measurement Ranges, Accuracy

Measurement Range

Current	$0.05 \dots 10 \times I_n$
Voltage	$0.65 \dots 1.1 \times U_n$

Accuracy

Current (I/I_n)	typical: $\pm 3 \%$
Voltage (U)	typical: $\pm 3 \%$
Active Power	typical: $\pm 5 \%$
Earth Fault Measurement	typical $\pm 5 \%$

Connection Diagram

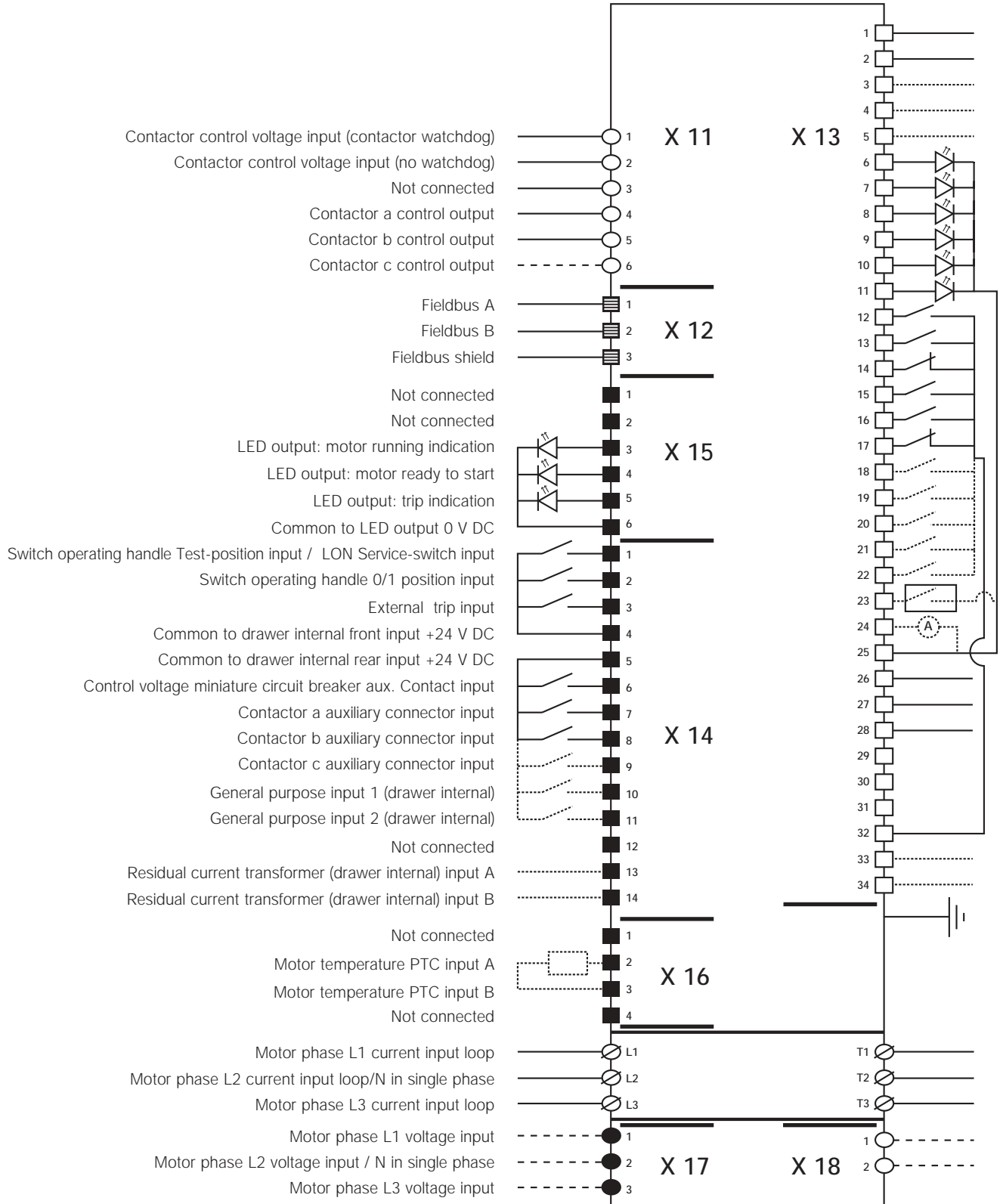

Contactor watchdog signalling output
 Contactor watchdog signalling output
 General purpose output relay 1 (drawer internal wiring)
 General purpose output relays common
 General purpose output relay 2 (drawer internal wiring)
 LED output for motor running direction 1 indication
 LED output for motor running direction 2 indication
 LED output for motor ready to be started indication
 LED output for alarm indication
 LED output for trip indication
 LED output for Local control state indication
 Motor start direction 1 switch input
 Motor start direction 2 switch input
 Motor stop switch input
 Reset switch input
 MCU local/remote control switch input
 Emergency stop auxiliary contact input
 Limit position switch 1 input
 Limit position switch 2 input
 Torque sensor for actuator type motor
 General purpose input 1 (drawer external wiring)
 General purpose input 2 (drawer external wiring)
 Rotation monitor input (contact)
 Analog Output (0-20 mA; 4-20 mA)
 Aux. power input 0 V DC (24 V DC variation) / common to drawer ext. I/O
 Aux. power input 0V DC
 Auxiliary power input +24 V DC
 Auxiliary power input +24 V DC
 Not connected
 Not connected
 Not connected
 24 V DIGI
 Residual current transformer (drawer external) input A
 Residual current transformer (drawer external) input B
 Device Ground

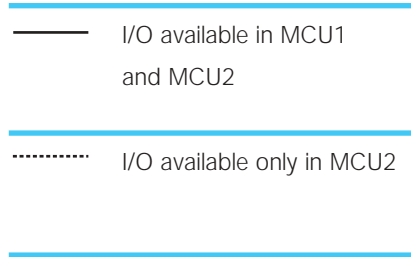

Motor phase L1 current output
 Motor phase L2 current output
 Motor phase L3 current output
 Aux. Power input L (for MCU with power supply in VU)
 Aux. Power input N (for MCU with power supply in VU)

MMI

Mechanical Data

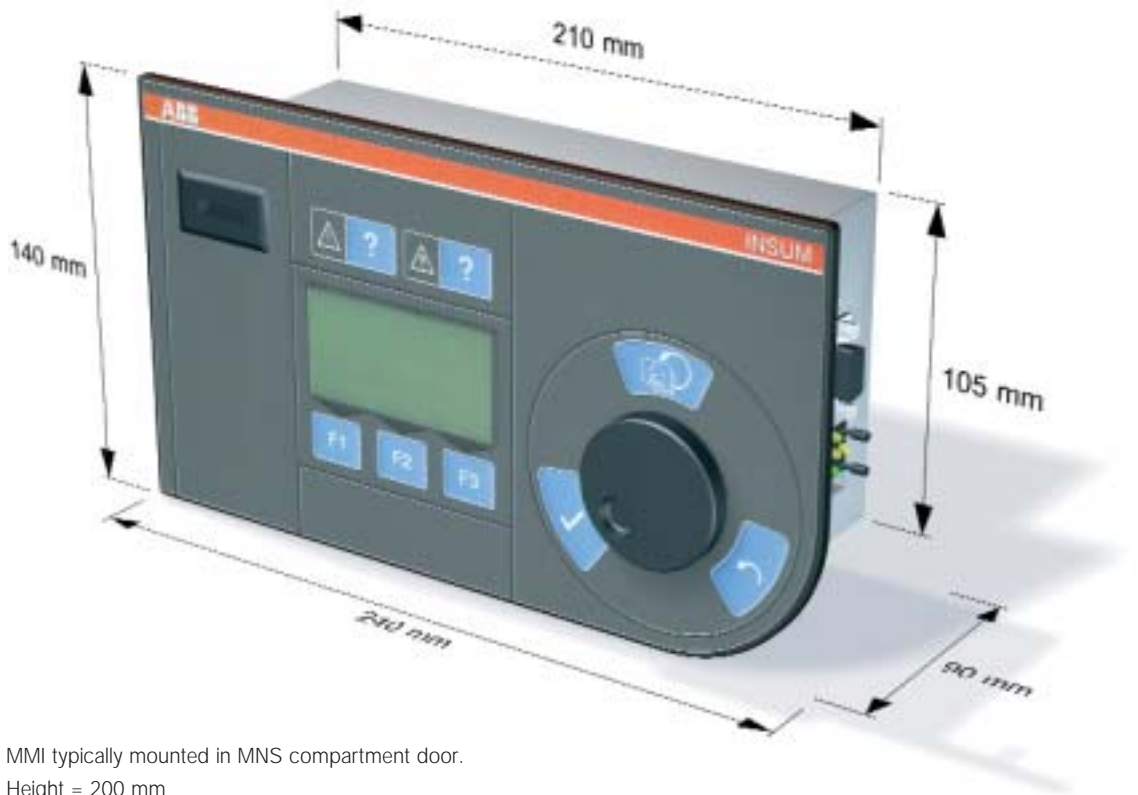

MMI typically mounted in MNS compartment door.
Height = 200 mm

Electrical Data

Power Supply

Operation Voltage	24 V DC (19 ... 33 V DC)
Power Consumption	approx. 5 W

Nominal Current	170 mA
Inrush Current	< 350 mA

Environmental Conditions

Storage Temperature	-20 °C to +80 °C
Operating Temperature	-5 °C to +70 °C
Degree of Protection	IP 21
MTBF	15 years

INSUM Communications Unit

Mechanical Data

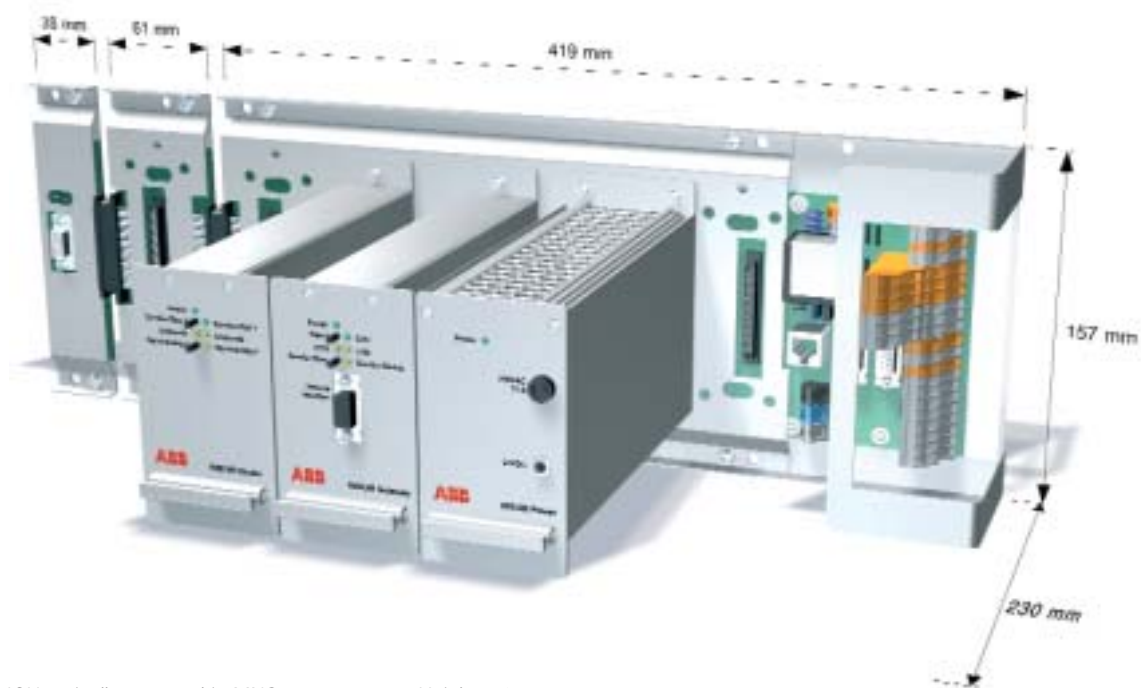

ICU typically mounted in MNS compartment. Height = 200 mm.

ICU reaches into the cable compartment, approx. 180 mm.

Electrical Data

	Router	Modbus Gateway	PROFIBUS Gateway	Ethernet Gateway	System Clock
Power Supply	24 V DC (19 V DC ... 33 V DC)				
Power Consumption (max.)	1.2 W	4.8 W	5.0 W	4.8 W	1.2 W
Nominal Current (typ.)	40 mA	130 mA	175 mA	160 mA	50 mA
Inrush Current	< 80 mA	< 350 mA	< 350 mA	< 300 mA	< 75 mA

Environmental Conditions

Storage Temperature	-20 °C to +80 °C
Operating Temperature	-5 °C to +70 °C
Degree of Protection	IP 30
MTBF	15 years

Connection Diagram

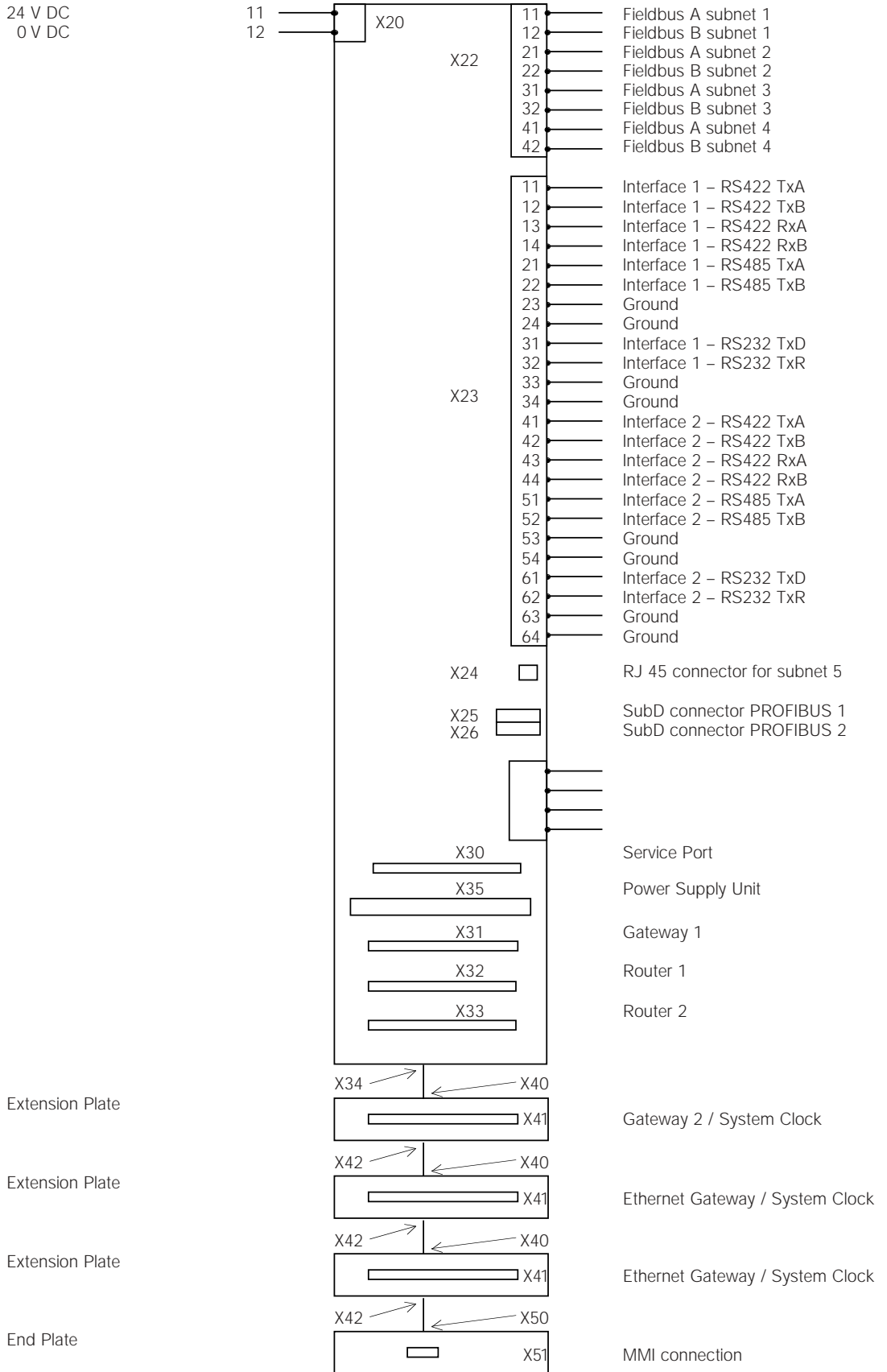

Number of devices connected to the backplane

Up to 2 Routers,
Up to 2 PROFIBUS or MODBUS or Ethernet Gateways,
1 Power Supply Unit,
Options: 2 Ethernet Gateways, System Clock

INSUM Operator Station OS

System Requirements

Hardware

Min. Intel Pentium 4 with 2 GHz or higher
Min. 512 MB RAM
SVGA or XGA Graphic Interface
CD-ROM Drive
TCP/IP compatible network adapter

Min. 50 MB Harddisk space for software installation w/o database.
(one database per ICU required)

Software

Microsoft Windows NT 4.0 SP 6 / 2000 SP 3 / XP SP 1
Microsoft Access 97 / 2000 / XP

Motor Control Unit (MCU)

Low Voltage Switchgear

Standard	Subject
IEC 60947-1	Low-voltage switchgear and controlgear Part 1: General rules, Edition 2.2 1998-11
IEC 60947-4-1	Low-voltage switchgear and controlgear Part 4: Contactors and motor-starters, First edition; 1990-07 Section 1 - Electromechanical contactors and motor-starters Amendment 1; 1994-11 Amendment 2; 1996-08
IEC 60947-5-1	Low-voltage switchgear and controlgear Part 5: Control circuit devices and switching elements, First edition; 1990-03 Section 1 - Electromechanical control circuit devices Amendment 1; 1994-05 Amendment 2; 1996-06

Electromagnetic Compatibility

Standard	Subject	Test criteria	Level
IEC 61000-3-2	Electromagnetic compatibility (EMC) Part 3-2: Limits for harmonic current emissions Harmonic Currents		Class A
IEC 61000-3-3	Electromagnetic compatibility (EMC) Part 3-3: Limitation of voltage fluctuations and flicker in low-voltage supply systems Voltage fluctuation and flicker sensation	dc = 3.0 % dmax = 4.0 % dt = 200 ms Pst = 1.0	N/A
IEC 61000-4-2	Electromagnetic compatibility (EMC) Part 4-2: Testing and measurement techniques Electrostatic discharge immunity test Contact discharge Air discharge	4 kV 8 kV	2 3
IEC 61000-4-3	Electromagnetic compatibility (EMC) Part 4-3: Testing and measurement techniques Radiated, radio-frequency, electromagnetic field immunity test 80-1000 MHz Sinus modulation	10 V/m	3

Standard	Subject	Test criteria	Level
IEC 61000-4-4	Electromagnetic compatibility (EMC) Part 4-3: Testing and measurement techniques Electrical fast transient/burst immunity test AC input port AC output port Communication, PTC and I/O port	4 kV 4 kV 2 kV	4 4 3
IEC 61000-4-5	Electromagnetic compatibility (EMC) Part 4-5: Testing and measurement techniques Surge immunity test AC input Communication, PTC and I/O port	4 kV 2 kV	4 3
DIN EN 55022	Information technology equipment - Radio disturbance characteristics - Limits and methods of measurement Conducted emissions Radiated emissions	150 kHz - 30 MHz 30 MHz - 1000 MHz	Class B Class B
ENV 50204	Radiated electromagnetic field from digital radio telephones immunity test 900 MHz, pulse modulated	10 V/m	3

Environmental Conditions

Standard	Subject
IEC 60068-2-6	Vibration (sinusoidal)
IEC 60068-2-27	Shock and bump
IEC 60068-2-29	Bump
IEC 60068-2-30	Damp heat, cyclic

Approvals

The Motor Control Unit hardware version -4 and software version 3.x is in accordance with the regulations for overload protection of explosion-protected motors of the EEx e-type of protection Directive 94/9/EC (ATEX 100a).

Physikalisch-Technische Bundesanstalt: Certificate PTB 03 ATEX 3033 dated 9th September 2003.

INSUM Communications Unit (ICU) devices

Electromagnetic Compatibility

Standard	Subject	Test criteria	Level
EN 50081-1	Electromagnetic compatibility (EMC); generic emission standard 0.15 - 0.5 MHz: AC mains port *) 0.5 - 5 MHz : AC mains port *) 5 - 30 MHz: AC mains port*) 30 - 230 MHz: enclosure 230 - 1000 MHz: enclosure	66...56/56...46 dB μ V 56/46 dB μ V 60/50 dB μ V 30 dB μ V/m 37 dB μ V/m	B B B B B
IEC 61000-4-2	Electromagnetic compatibility (EMC) Part 4-2: Testing and measurement techniques Electrostatic discharge immunity test Contact discharge (MMI) Contact discharge (Router, Gateways) Air discharge (MMI only)	4 kV 6 kV 8 kV	2 3 3/PC 'B'
IEC 61000-4-3	Electromagnetic compatibility (EMC) Part 4-3: Testing and measurement techniques Radiated, radio-frequency, electromagnetic field immunity test 80 - 1000 MHz, Sinus modulation 895 - 905 MHz, Pulse modulation	10 V/m 10 V/m	3 3
IEC 61000-4-4	Electromagnetic compatibility (EMC) Part 4-3: Testing and measurement techniques Electrical fast transient/burst immunity test AC mains port *) 24 V DC Power Supply lines Communication Interface	4 kV 2 kV 2 kV	4 3 4
IEC 61000-4-5	Electromagnetic compatibility (EMC) Part 4-5: Testing and measurement techniques Surge immunity test AC mains port *): Asymmetrical / symmetrical 24 V DC Power Supply lines: Asymmetrical / symmetrical Communication Interface	2/1 kV 1/0.5 kV 2 kV	class 3 class 2 class 3
IEC 61000-4-6	Electromagnetic compatibility (EMC) Part 4-6: Testing and measurement techniques Immunity to conducted disturbances, induced by radio-frequency fields AC mains port *) 24 V DC Power Supply lines Communication Interface	10 V 10 V 10 V	3 3 3

* only with INSUM Power Supply Unit 1TGB 302006

Standard	Subject	Test criteria	Level
IEC 61000-4-11	Electromagnetic compatibility (EMC) Part 4-11: Testing and measuring techniques Voltage dips, short interruptions and voltage variations immunity tests AC mains port *) Voltage dips 40 % Un	1000 ms	PC 'A'
IEC 61000-4-29	Electromagnetic compatibility (EMC) Part 4-29: Testing and measurement techniques Voltage dips, short interruptions and voltage variations on d.c. input power port immunity tests Voltage dips 24 V DC 70 % Un Voltage dips 24 V DC 40 % Un Voltage interruption 24 V DC	1000 ms 100 ms 30 ms	PC 'A' PC 'A' PC 'A'
IEC 60255-5	Electrical Relays Part 5: Insulation coordination for measuring relays and protection equipment Requirements and tests 24 V DC Ground plane 24 V DC Internal bus lines Bus lines Ground plane	+/- 0.8 kV +/- 0.8 kV +/- 0.8 kV	3 3 3

* only with power supply unit 1TGB 302006

Environmental Conditions

Standard	Subject
IEC 60255-21-1	Vibration (sinusoidal)
IEC 60255-21-2	Shock and bump
IEC 60068-2-1	Cold
IEC 60068-2-2	Dry heat
IEC 60068-2-6	Vibration (sinusoidal)
IEC 60068-2-30	Damp heat, cyclic



ABB Low Voltage Systems
www.abb.com/mns