

Accessories for interface relays CR-P and CR-M

Pluggable time modules CR-P/M T...

Data sheet



CR-P/M T...

- ① Potentiometer for the fine adjustment of the desired time
- ② green LED -  : Output relay energized
- ③ DIP switch to pre-select one of the 4 time ranges from 1.5 s - 64 min

Features

- Rated control supply voltage U_s 12-24 V AC/DC
- One device includes 4 time ranges from 1.5 s to 64 min
- LED for status indication
- 15,5 mm width
- can be combined with the pcb relays CR-P and the miniature relays CR-M, pluggable into the sockets CR-PLS, CR-PLC, CR-M...LS, CR-M4LC

Approvals

 UL 60950, CAN/CSA C22.2 No 60950

Marks

 CE

Order data

| Type | Timing function | Order code |
|-------------|-----------------|--------------------|
| Time module | | |
| CR-P/M T1 | ON-delay | 1SVR 405 657 R0000 |
| CR-P/M T2 | Impulse-ON | 1SVR 405 657 R0100 |

Application

The time modules CR-P/M T... can be plugged into the sockets CR-PLS, CR-PLC, CR-M2LS, CR-M3LS, CR-M4LS and CR-M4LC of the CR-P and CR-M range 2-, 3- or 4-pole pluggable interface relays. This way very compact 2-, 3- or 4-pole time relays with a rated operational current of up to 16 A can be provided.

Operating mode

The CR-P/M T... offer 4 time ranges, adjustable with DIP switches. The fine adjustment of the time delay is made via the thumbwheel on the front of the unit.

Function diagrams

On-delay (CR-P/M T1)

Timing begins when control supply voltage is applied. When the selected time delay is complete, the output relay energizes and the green LED glows.

If control supply voltage is interrupted, the output relay de-energizes, the time delay is reset and the green LED turns off.

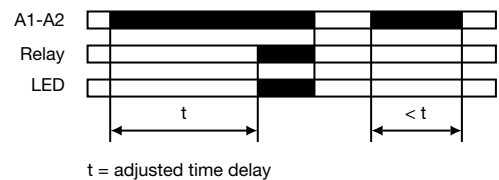

Impulse-ON (CR-P/M T2)

This function requires continuous control supply voltage. The output relay energizes immediately when control supply voltage is applied and de-energizes when the set pulse time is complete. The green LED glows as long as the relay is energized.

If control supply voltage is interrupted, the output relay de-energizes and the time delay is reset.

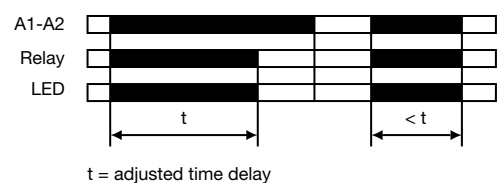

Accessories for interface relays CR-P and CR-M

Pluggable time modules CR-P/M T...

Data sheet

Connection diagram

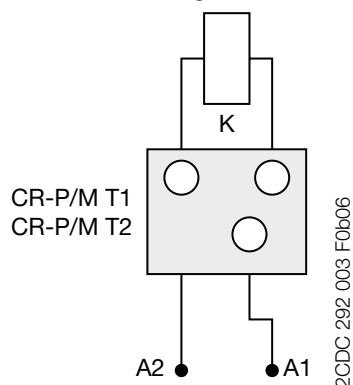

DIP switch position

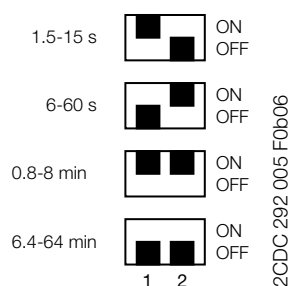

Technical data

| Type | | CR-P/M T... |
|--|----------------------|--|
| Input circuit - Supply circuit | | A1-A2 |
| Rated control supply voltage U_s | | 12-24 V AC/DC |
| Rated control supply voltage tolerance | | -25...+25 % |
| Frequency range | | 50-60 Hz |
| Typ. power consumption | at 12 V DC | 75 mW |
| | at 24 V DC | 150 mW |
| | at 12 V AC | 100 mW |
| | at 24 V AC | 200 mW |
| Residual ripple at DC | | 0 |
| Release voltage | | 9 V |
| Timing circuit | | |
| Timing functions | CR-P/M T1 | <input checked="" type="checkbox"/> ON-delay, |
| | CR-P/M T2 | <input type="checkbox"/> Impulse-ON |
| Time ranges | 15 s | 1.5 -15 s |
| | 60 s | 6-60 s |
| | 8 min | 0.8-8 min |
| | 64 min | 6.4-64 min |
| Base accuracy | | ±30 % (of full-scale) |
| Timing error within the rated control supply voltage tolerance | | - |
| Timing error within the temperature range | | ±30 % |
| Output circuit | | |
| | | depending on the interface relay CR-P or CR-M used |
| Environmental data | | |
| Temperature range | operation (IEC 68-1) | 0...+50 °C |
| | storage | -20...+70 °C |
| Humidity | | 20-90 %, no condensation |
| Climatic category | IEC 721-3-3 | 3K3 |
| Pollution degree | IEC 664-1 | 2 |
| Indication of operational states | | |
| green LED | | Output relay energized |
| Operating controls | | |
| Tolerance of setting | | - |

Accessories for interface relays CR-P and CR-M

Pluggable time modules CR-P/M T...

Data sheet

| General data | | |
|---|------------------|---|
| Duty time | | 100 % |
| Repeat accuracy (constant parameters) | scale 1.5-15 s | ±0,2 |
| | scale 6-60 s | ±0,2 |
| | scale 0.8-8 min | ±1 |
| | scale 6.4-64 min | ±2 |
| Dimensions (W x H x D) | when mounted | 15.5 mm x 24.5 mm x 11.6 mm |
| Material of enclosure | | Pa6 +20% GF, UL 94 V2 |
| Degree of protection | | IP30 |
| Mounting | IEC 67-1-18a | pluggable into sockets CR-PLS, CR-PLC, CR-M2LS, CR-M3LS, CR-M4LS, CR-M4LC |
| Mounting position | | any |
| Standards | | |
| RoHS directive | | 2002/95 EC |
| Conformity | | CEI-EN 60730-2-7 |
| Electromagnetic compatibility | | |
| electrostatic discharge (ESD) | | CEI-EN 61000-6-2 |
| electromagnetic field (HF radiation resistance) | | CEI-EN 61000-6-3 |

Dimensions

in mm

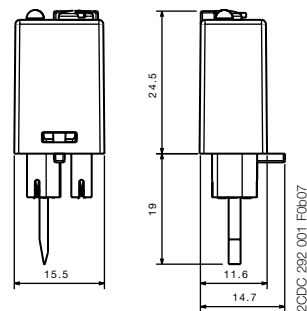

Further documentation

| Document title | Document type | Document number |
|----------------|---------------|--------------------|
| Sockets CR-P | Data sheet | 2CDC 117 004 D0203 |
| Relays CR-P | Data sheet | 2CDC 117 001 D0203 |
| Sockets CR-M | Data sheet | 2CDC 117 005 D0203 |
| Relays CR-M | Data sheet | 2CDC 117 002 D0203 |



As part of the on-going product improvement, ABB reserves the right to modify the characteristics of the products described in this document. The information given is non-contractual.

For further details please contact (www.abb.com/contacts) the ABB company marketing these products in your country.

Document number: 2CDC 117 011 D0201 (02/2008)

ABB STOTZ-KONTAKT GmbH

Eppelheimer Strasse 82, 69123 Heidelberg, Germany
Postfach 10 16 80, 69006 Heidelberg, Germany
Internet <http://www.abb.com/lowvoltage> → Control Products

Contact: <http://www.abb.com/contacts> → Low Voltage Products and Systems