

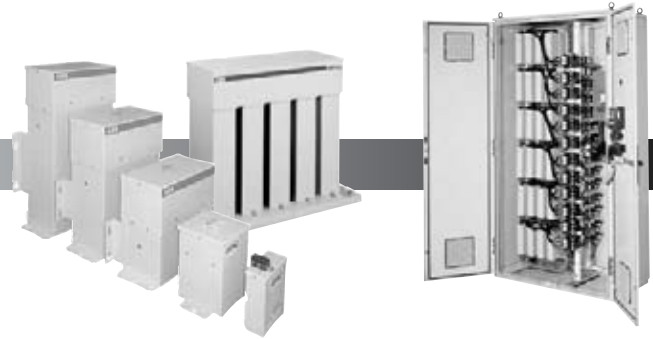

21 - Low Voltage Network Quality



General information21.1 - 21.6

Description & capacitor construction	21.2, 21.3
Options for correcting power factor.....	21.4
Sizing capacitors at the motor load.....	21.5
Sizing capacitors at the motor load using charts	21.6

Individual units.....21.7 - 21.20

Selection	
3 phase, 480V	21.10
3 phase, 600V	21.11
Catalog number explanation.....	21.8
Description	21.7
Fuse and blown fuse indication, 3 phase, 240V	21.12
Fuse and blown fuse indication, 3 phase, 480V	21.13
Fuse and blown fuse indication, 3 phase, 600V	21.14
General information.....	21.8
3 phase, 240V	21.9
Pump jack, 240V & 480V	21.15
Type CLMD-13, 208, 240, 480 & 600 V.....	21.16
Type CLMD-13SC, Stud connected, 208, 240, 480 & 600V.....	21.17
Dimensions	
Individual capacitors	21.18, 21.19, 21.20

Fixed banks21.21 - 21.26

Selection	
3 phase, 240 & 480V w/3 fuses & blown fuse indication	21.23
3 phase, 600V w/3 fuses & blown fuse indication.....	21.24
3 phase, internally protected elements, 240 & 480V	21.21
3 phase, internally protected elements, 600V.....	21.22
Dimensions	
Fixed bank, wall mounted.....	21.26
Fixed capacitor bank, floor mounted.....	21.25

AutoBank 300 & 121021.27 - 21.34

Selection	
AutoBank 1200, 480 & 600V	21.30
AutoBank 300	21.29
Catalog number explanation.....	21.28
Description & technical data.....	21.28
Factory modifications	21.31
Description.....	21.27
Dimensions	
AutoBank 300	21.32
Current transformer.....	21.31

Dynacomp21.35 - 21.36

Selection	
Catalog numbering explanation.....	21.36
Description.....	21.35
General information.....	21.36
Typical applications.....	21.35

Power Active Filter, Type PQF21.37 - 21.40

Selection	
Advantages of the PQF.....	21.38
Description.....	21.37
Harmonics and power quality	21.38
PQF ratings and capabilities.....	21.39
PQF sizing information.....	21.37
Power quality filter	21.38
The ABB Solution: PQF.....	21.38
The PQF-Manager	21.39
Typical application	21.37

Application manual.....21.41 - 21.58

ABB Capacitor features & services.....	21.50
Application and installation.....	21.45, 21.46, 21.47
Avoiding resonance.....	21.49
Basic concepts	21.42
Capacitor installation locations.....	21.44
Capacitor rating	21.43
Contactors kvar ratings	21.45
Discharging time	21.45
Extract from NEC, Separate overcurrent protection	21.57
General information.....	21.42, 21.43
Harmonic analysis.....	21.49
Harmonic content	21.48
Harmonic overloading of capacitors.....	21.48
Harmonic phenomena.....	21.48, 21.49, 21.50
How capacitors solve low power factor.....	21.43
Load alteration	21.49
Origins of harmonic distortion.....	21.48
Overcoming resonance	21.49
Problems created by harmonics	21.48
Recommended ratings of cables & protective devices	21.55, 21.56
Reduction of harmonic distortion	21.49
Sizing capacitors at the motor load - using charts	21.52, 21.53
Sizing capacitors at the motor load - using formulas.....	21.51
Sizing capacitors at the motor load using charts	21.54
Sizing capacitors for improving system power factor.....	21.53
Special applications.....	21.45
Types of filters	21.49
Typical capacitor specifications.....	21.45
Why improve low power factor?	21.42
Wiring diagrams	21.46, 21.47

Low Voltage Network Quality



Low Voltage Network Quality

Power factor correction

Harmonic filtering

Dynamic flicker compensation

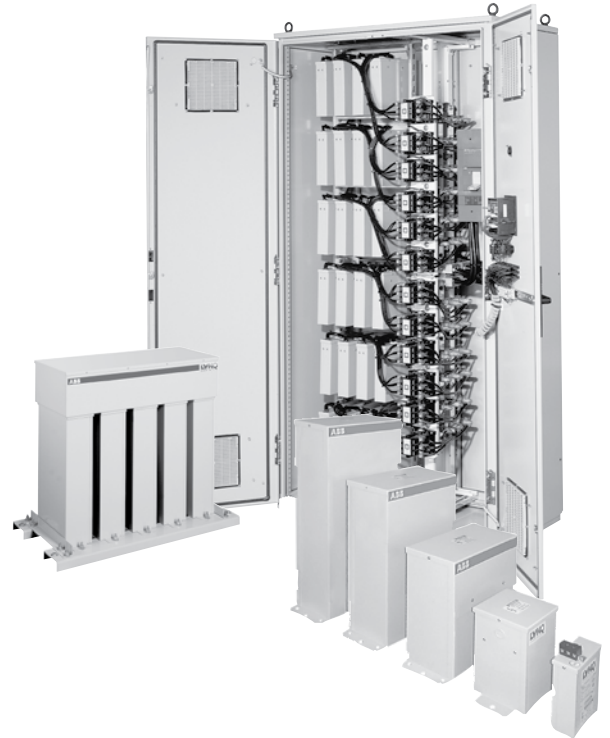

General information

Description & capacitor construction



- Large terminals for easy cable connections
- Built-in discharge resistors
- Heavy duty enclosure
- Metallized film design
- Internally Protected Elements (IPE) & self-healing design
- Low losses
- Thermal equalizer for low element temperature
- Dry granulated vermiculite insulation
- Easy mounting, low weight



Principal Components of a 3-Phase Capacitor

The principal components of a 3-phase ABB capacitor include:

1. Sequential Protection System:

• Self-Healing Capacitor Elements

One or more self-healing capacitor elements are installed for each phase. These elements are connected in Y or Δ. In case of dielectric breakdown, the fault is cleared by evaporation of the metallized layer around the breakdown with negligible loss of capacitance and continued operation of the capacitor!

• Internally Protected Elements

A unique Sequential Protection System including the IPE design (IPE - internally protected elements) ensures that each individual element can be disconnected from the circuit at the end of the element's life.

• Nonflammable Dry Vermiculite Filler

Vermiculite is a dry, granular insulating material that is solid, inert and fire proof. This material fills all open spaces in the enclosure to isolate the capacitor elements and exclude free oxygen.

2. Discharge Resistors

Discharge resistors (one for each phase) are sized to ensure safe discharge of the capacitor to less than 50 volts in one minute or less as required by the NEC.

3. Terminal Studs

Large terminal studs are located inside the enclosure at the top of the capacitor for quick and easy cable connections.

4. Enclosure

All ABB enclosures are made of welded heavy gauge steel. Available enclosure types include Indoor NEMA 1, Outdoor Raintight, and Indoor Dusttight. (RAL 7032, Beige)

What is a Metallized-Film Element?

Metallized-film is a microscopically thin layer of conducting material (called an electrode), usually aluminum or zinc on an underlying layer of insulating film. The electrode thickness averages only .01 microns while insulating (polypropylene) film ranges from 5 to 10 microns in thickness depending upon the design voltage of the capacitor (the higher the voltage rating, the thicker the insulating film).

Advantages of Metallized-Film Elements

There are two electrode layers separated by one layer of insulating film. Thousands of these layers are tightly wound around a core in such a manner that the edge of one electrode is exposed on one side of the element and the edge of the other electrode is exposed on the other side of the element. See Fig. 1 & 2.



Fig. 1

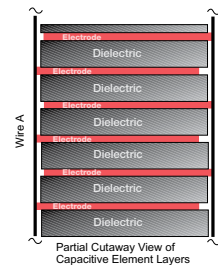

Fig. 2

Wires are then connected to each side of the element. The element is enclosed in a container and then filled with a hardening protective sealant.

1. Self-Healing Design

General information Description & capacitor construction

Self-healing refers to a process where a short circuit between electrodes vaporizes the electrode around the fault (see Fig. 14) until the fault is eliminated. The element continues to function with negligible loss of performance (see Fig. 15).

2. Low Internal Losses

Due to the high dielectric efficiency of the metallized-film, the internal losses are extremely low. ABB metallized-film design losses are limited to .5 watts per kvar including the losses across the discharge resistors.

3. Small Element Size

Due to the thin electrode and dielectric, metallized-film elements are small and compact in size resulting in smaller, more powerful capacitors.

The capacitance of any element design is inversely proportional to the separation between electrodes. In other words, if the separation between conducting surfaces is cut in half, the effective capacitance is doubled in addition to reducing the physical size of the element by half.

More About Self Healing Elements

"Self-healing" is a characteristic which is unique to metallized electrode capacitors. All capacitors normally experience insulation breakdown as a result of the accumulated effect of temperature, voltage stress, impurities in the insulating medium, etc. When this happens in a non-"metallized" design,

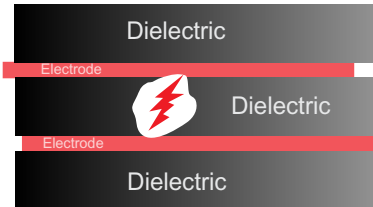

Fig. 3. Two electrodes short circuit through a fault in a dielectric layer.

the electrodes are short-circuited and the capacitor ceases its production of reactive power. In an ABB metallized-film unit, however, these individual insulation breakdowns do not mean the shutdown of the capacitor. The faults self-heal themselves and the capacitor continues operation.

The conducting electrode is very thin; when a short circuit develops as a result of a fault in the insulating dielectric, the thin electrode vaporizes around the area of the fault. This vaporization continues until sufficient separation exists between the faulted electrodes to overcome the voltage level. Fig. 15 illustrates the process of self-healing.

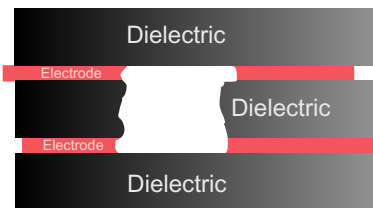

Fig. 4 illustrates "self-healing". The electrode layers in the area where they were short circuiting have been vaporized, thereby eliminating the short circuit.

The entire process of self-healing takes "microseconds" and the amount of electrode which is lost is negligible in comparison to the total surface area of the element. The result is the metallized-film unit may self-heal hundreds of times during its long life and still retain virtually all of its rated capacitance.

The IPE Sequential Protection System

ABB's metallized-film self healing capacitor elements will have a longer life than their conventional foil design counterparts for the above reason. However, accumulated effects of time, temperature, voltage stress, etc., eventually effect capacitor life.

ABB's sequential protection system featuring patented Internally Protected Elements (IPE) design provides increased protection to facilities and personnel not available from other capacitor designs. This proven design allows for self-healing throughout the life of the capacitor to insure the maximum length of reliable service and still provide short circuit protection in each element when self-healing can no longer continue. This is accomplished by a combination of unique winding construction and an internal fuse link (See Fig. 5) within each element which

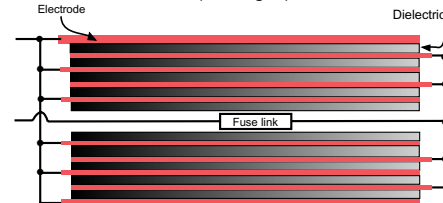

Fig. 5

safely and selectively disconnects each individual element. ABB capacitors do not rely on mechanical pressure interrupters and additional line fuses have disadvantages associated with that kind of construction.

What are Discharge Resistors?

As all the capacitor elements store electrical power like a battery, the capacitor will maintain a near full charge even when not energized. As this is a potentially dangerous condition to unsuspecting plant personnel that might be inspecting the capacitor terminals and wiring, discharge resistors are connected between all of the terminals. When the capacitor is shut off, these discharge resistors drain the capacitor elements of their stored electrical charge. It is recommended, however, that capacitor terminals should ALWAYS be short-circuited before touching the terminals.

What is the Significance of Dry Type Design?

ABB low voltage capacitors contain no free liquids and are filled with a unique nonflammable granular material called vermiculite. Environmental and personnel concerns associated with leakage or flammability of conventional oil-filled units are eliminated; and kvar for kvar, vermiculite filled units weigh 30% to 60% less than their oil filled counterparts.

Vermiculite is routinely used in the United States as an insulating material in the walls and ceilings of new buildings. Its properties have been extensively documented and recognized as an ideal material for safety and environmental considerations.

General information

Options for correcting power factor

Options for Correcting Power Factor

There are three primary methods of correcting power factor:

- **Individual Capacitor Units** - One capacitor unit for each inductive load.
- **Banks of Capacitor Units** - Large Capacitor System connected to the line at some central point in the distribution system.
- **Combination of Above** - Where individual capacitors are installed on the larger inductive loads and banks are installed on main feeders or switchboards, etc.

Individual Capacitor Units

Power factor correction is best achieved with individual capacitor units located directly at the inductive load (in most cases a motor). This has many of the advantages of capacitor bank installations including some advantages capacitor bank installations cannot offer.

Advantages of individual capacitor units:

- **Increased Distribution System Capacity** - Only individual capacitor units can improve power consumption efficiency throughout the entire distribution system all the way to the load! Therefore, where wiring is being overloaded by induction motors, increased system capacity can be obtained by reducing the load and adding individual power factor correction units.
- **Stabilized Voltage Levels** - Voltage drops to individual inductive load are reduced by decreasing heat damage caused by excessive currents.
- **Lower Losses** - When individual capacitor units are installed directly at the terminals of an inductive load such as a motor or transformer, the line losses are reduced.
- **Capacitor & Load Can Be Switched ON/OFF Together** This ensures that the motor cannot operate without the capacitor; and also ensures that the capacitor only operates when needed.

Fixed and Automatic Capacitor Banks

Group installation of capacitors is achieved in two ways:

- **Fixed Capacitor Banks** - Individual capacitors racked in a common enclosure with no switching or stepping capability.
- **Automatic Capacitor Banks** - Individual capacitors racked in a common enclosure with switching capability. The capacitors are turned on and off by a micro-processor based controller. The controller also provides network data and alarm conditions to the user. Network data consists of power factor, volts, amps and harmonic distortion.

Advantages of fixed or automatic bank systems

- **More Economical** - Capacitor banks are more economical than individual capacitor units when the main reason for power factor correction is to reduce utility power bills and/or reduce the current in primary feeders from a main generator or transformer. Large banks or racks of capacitors are installed at the main switchboard or at the substation thereby increasing power factor and obtaining the advantages of lower power consumption.
- **Lower Installation Costs** - The cost of installing one fixed or automatic capacitor bank unit will be less than installing a number of individual capacitors at inductive loads.



- **Switching** - Automatic capacitor banks can switch all or part of the capacitance automatically depending on load requirements. This way, only as much power factor correction as needed for the given load is provided. (This switching capability is a primary advantage over fixed capacitor banks where over-capacitance, leading power factor and resulting overvoltages can occur should the load decrease.)
- **Monitoring** - Automatic capacitor bank controllers provide network data and alarm conditions to the user. Network data consists of power factor, volts, amps and harmonic distortions.

General information

Sizing capacitors at the motor load

Sizing Capacitors at the Motor Load

When the determination is made that power factor correction capacitors ARE a good investment for a particular electrical system, you need to know:

- How many capacitors are needed?
- What sizes are appropriate?

The capacitor provides a local source of reactive current. With respect to inductive motor load, this reactive power is the magnetizing or "no-load current" which the motor requires to operate.

A capacitor is properly sized when its full load current rating is 90% of the no-load current of the motor. This 90% rating avoids overcorrection and the accompanying problems such as overvoltages.

One Selection Method: Using Formulas

If no-load current is known . . .

The most accurate method of selecting a capacitor is to take the no-load current of the motor, and multiply by .90 (90%). Take this resulting figure, turn to the appropriate catalog page, and determine which kvar size is needed, catalog number, enclosure type, and price.

EXAMPLE: Size a capacitor for a 100hp, 460V 3-phase motor which has a full load current of 124 amps and a no-load current of 37 amps.

1. Multiply the no-load current figure of 37 amps by 90%.
37 no load amps X 90% = 33 no load amps

2. Turning to the catalog page for 480 volt, 3-phase capacitors, find the closest amp rating to, but NOT OVER 33 amps. See Table 1, sample catalog pricing chart. Per the sample chart the closest amperage is 32.5 amps. The proper capacitor unit, then is 27 kvar and the appropriate catalog number depends on the type enclosure desired.

NOTE: The formula method corrects power factor to approximately .95

If the no load current is not known . . .

If the no-load current is unknown, a reasonable estimate for 3-phase motors is to take the full load amps and multiply by 30%. Then take that figure and multiply times the 90% rating figure being used to avoid overcorrection and overvoltages. EXAMPLE: Size a capacitor for a 75hp, 460V 3-phase motor which has a full load current of 92 amps and an unknown no-load current.

1. First, find the no-load current by multiplying the full load current times 30%.
92 (full load amps) X 30% = 28 estimated no-load amps
2. Multiply 28 no-load amps by 90%.
28 no-load amps X 90% = 25 no-load amps
3. Now examine the capacitor pricing and selection chart for 480 volt, 3-phase capacitors. Refer again to Table 1. Here it will be seen that the closest capacitor to 25 amps full load current without going over is a 20 kvar unit, rated at 24.1 amps.
4. The correct selection, then, is 20 kvar!

TABLE 1
480 VOLT, 60 Hz., 3-Phase

Enclosure Size	kvar Rating	Rated Current Per Phase	Approx. Shipping Weight (Lbs.)	Indoor – Nema 1	Outdoor – Nema 3R	Indoor – Nema 12
				Catalog Number	Catalog Number	Catalog Number
	1.5	1.8	8	C484G1.5	C484R1.5	C484D1.5
	2	2.4	8	C484G2	C484R2	C484D2
	2.5	3.0	8	C484G2.5	C484R2.5	C484D2.5
	3	3.6	8	C484G3	C484R3	C484D3
	4	4.8	8	C484G4	C484R4	C484D3.5
	5	6.0	8	C484G5	C484R5	C484D4
	6	7.2	8	C484G6	C484R6	C484D4.5
	7	8.4	8	C484G7	C484R7	C484D5
	8	9.6	8	C484G8	C484R8	C484D5.5
	9	10.8	8	C484G9	C484R9	C484D6
	10	12.0	8	C484G10	C484R10	C484D6.5
	11	13.2	8	C484G11	C484R11	C484D7
	12	14.4	8	C484G12	C484R12	C484D7.5
	13	15.6	8	C484G13	C484R13	C484D8
	14	16.8	8	C484G14	C484R14	C484D8.5
	15	18.0	8	C484G15	C484R15	C484D9
	16	19.2	8	C484G16	C484R16	C484D9.5
	17	20.4	8	C484G17	C484R17	C484D10
	18	21.6	8	C484G18	C484R18	C484D10.5
	19	22.8	8	C484G19	C484R19	C484D11
	20	24.0	8	C484G20	C484R20	C484D11.5
	21	25.2	8	C484G21	C484R21	C484D12
	22	26.4	8	C484G22	C484R22	C484D12.5
	22.5	27.1	8	C484G22.5	C484R22.5	C484D13
	24	28.8	8	C484G24	C484R24	C484D14
	25	30.0	8	C484G25	C484R25	C484D14.5

General information

Sizing capacitors at the motor load

Using charts

An Alternate Selection Method – Using Charts

TABLE 2: Suggested Maximum Capacitor Ratings for T-Frame NEMA Class B Motors

Induction motor rating (HP)	NOMINAL MOTOR SPEED											
	3600 R/MIN		1800 R/MIN		1200 R/MIN		900 R/MIN		720 R/MIN		600 R/MIN	
	Capacitor rating (kvar)	Line current reduction (%)	Capacitor rating (kvar)	Line current reductions (%)	Capacitor rating (kvar)	Line current reduction (%)	Capacitor rating (kvar)	Line current reduction (%)	Capacitor rating (kvar)	Line current reduction (%)	Capacitor rating (kvar)	Line current reduction (%)
3	1.5	14	1.5	23	2.5	28	3	38	3	40	4	40
5	2	14	2.5	22	3	26	4	31	4	40	5	40
7.5	2.5	14	3	20	4	21	5	28	5	38	6	45
10	4	14	4	18	5	21	6	27	7.5	36	8	38
15	5	12	5	18	6	20	7.5	24	8	32	10	34
20	6	12	6	17	7.5	19	9	23	12	25	18	30
25	7.5	12	7.5	17	8	19	10	23	12	25	18	30
30	8	11	8	16	10	19	14	22	15	24	22.5	30
40	12	12	13	15	16	19	18	21	22.5	24	25	30
50	15	12	18	15	20	19	22.5	21	24	24	30	30
60	18	12	21	14	22.5	17	26	20	30	22	35	28
75	20	12	23	14	25	15	28	17	33	14	40	19
100	22.5	11	30	14	30	12	35	16	40	15	45	17
125	25	10	36	12	35	12	42	14	45	15	50	17
150	30	10	42	12	40	12	52.5	14	52.5	14	60	17
200	35	10	50	11	50	10	65	13	68	13	90	17
250	40	11	60	10	62.5	10	82	13	87.5	13	100	17
300	45	11	68	10	75	12	100	14	100	13	120	17
350	50	12	75	8	90	12	120	13	120	13	135	15
400	75	10	80	8	100	12	130	13	140	13	150	15
450	80	8	90	8	120	10	140	12	160	14	160	15
500	100	8	120	9	150	12	160	12	180	13	180	15

Applies to three-phase, 60Hz motors when switched with capacitors as a single unit.

Another method of selecting the proper capacitor employs the use of only a selection chart shown in Table 2 or 3. These tables take other variables such as motor RPM into consideration in making recommendations for capacitor applications. They are convenient because they only require that the user know the horsepower and RPM of the motor. Both tables estimate the percentage reduction in full load current drawn by the motor as a result of the capacitor's installation.

TABLE 3: Suggested Maximum Capacitor Ratings for U-Frame NEMA Class B Motors

NEMA Motor Design A or B
Normal Starting Torque
Normal Running Current

H.P. Rating	3600 RPM		1800 RPM		1200 RPM		900 RPM		720 RPM		600 RPM	
	kvar	%AR	kvar	%AR	kvar	%AR	kvar	%AR	kvar	%AR	kvar	%AR
3	1.5	14	1.5	15	1.5	20	2	27	2.5	35	3.5	41
5	2	12	2	13	2	17	3	25	4	32	4.5	37
7.5	2.5	11	2.5	13	2	15	4	22	5.5	30	6	34
10	3	10	3	11	3.5	14	5	21	6.5	27	7.5	31
15	4	9	4	10	5	13	6.5	18	8	23	9.5	27
20	5	9	5	10	5	11	7.5	18	10	20	10	25
25	5	6	5	8	7.5	11	7.5	13	10	20	10	21
30	5	5	5	8	7.5	11	10	15	15	22	15	25
40	7.5	8	10	8	10	10	15	16	15	18	15	20
50	10	7	10	8	10	9	15	12	20	15	25	22
60	10	6	10	8	15	10	15	11	20	15	25	20
75	15	7	15	8	15	9	20	11	30	15	40	20
100	20	8	20	8	25	9	30	11	40	14	45	18
125	20	6	25	7	30	9	30	10	45	14	50	17
150	30	6	30	7	35	9	40	10	50	17	60	17
200	40	6	40	7	45	8	55	11	60	12	75	17
250	45	5	45	6	60	9	70	10	75	12	100	17
300	50	5	50	6	75	9	75	9	80	12	105	17

Applies to three-phase, 60Hz motors when switched with capacitors as a single unit.

WARNING!

Never oversize capacitors or exceed 1.0 power factor or resulting problems with the motor can occur!!

If calculations or a kvar determination chart indicate a kvar rating not found in a pricing and selection chart, always refer to the next lower kvar rating!

EXAMPLE: A manufacturer needs to determine the proper capacitors required for a 1200 RPM, 75HP T-Frame NEMA class B motor.

1. First find 75 in the horsepower column of the chart.
2. Locate the 1200 RPM capacitor rating (kvar) column. Note the figure of 25 kvar.
3. Now refer to the appropriate pricing and selection chart Table 1, page 19.5. The appropriate kvar rating is 25 kvar. Depending on the desired enclosure, the price and catalog number can then be easily determined.

NOTE

Using the above charts for selecting capacitors will correct power factor to approximately .95.



Individual & fixed bank Capacitors

Description

- **High reliability**
Well proven features of ABB dry type power factor correction capacitor technology are incorporated into individual and fixed bank designs.
- **Very low losses**
Capacitor total losses are less than 0.5 watts per kvar.
- **Discharge mechanism**
Carbon filament or wire-wound resistors sized to automatically discharge the capacitor to less than 50 volts in under one minute.
- **Tolerance on capacitance**
0%, +15%
- **Overcurrent tolerance**
135% of rated current, continuously
- **Overvoltage tolerance**
110% of rated voltage, continuously
- **Standard ambient temperature range**
-40°C to +40°C (-40°F to +104°F)
- **Internal cables and insulation**
All internal conductors utilize stranded, tin plated copper wire. Insulation is fire-retardant, rated 105°C (220°F).
- **Complete environmental acceptability**
ABB capacitors have a dry type dielectric with no free liquid and do not pose any risk of leakage or pollution of the environment. Therefore, employee safety training and maintenance of Material Safety Data Sheets are not required with these capacitors.
- **Unique sequential protection system**
Patented system ensures that each individual capacitor element is selectively and reliably disconnected from the circuit at the end of its life.

continued next page

General information

Catalog number explanation

Fuse protection

- ABB capacitors are provided with patented IPE (Internally Protected Elements) which is an integral and important part of the Sequential Protection System. Additional fuses are NOT required for protection of ABB capacitor elements, but external overcurrent protection may be needed for the installation in order to meet the National Electric Code requirements concerning protection of the conductors feeding the capacitors.

Long life

Low losses and the self-healing properties of ABB capacitor elements help to guarantee the long operating life of individual and fixed capacitor banks from ABB.

Safety

Vermiculite, a nonflammable and nontoxic material, safely absorbs any energy produced within the capacitor enclosure.

Approvals

- UL, CE and CSA approved
 - UL File #E135667
 - CSA File #LR88616
- Complies with applicable requirements of IEC, NEC®, NEMA CP-1, ANSI and IEEE std. 18.

Factory modifications

- Mounting brackets
- Terminal connected fuses & blown fuse indication
- State indication

NOTE: National Electric Code® and NEC® are registered trademarks of the National Fire Protection Association, Inc., Quincy, MA 02269

C 48 4 G 2.5 - 2LF

Catalog number explanation

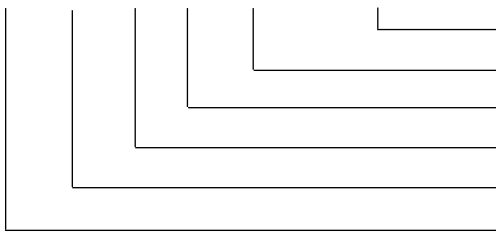

Factory modifications

kvar rating

Enclosure type – **G**=NEMA 1, **R**=NEMA 3R, **D**=NEMA 12

Enclosure size – **4**=43, **5**=53, **6**=63, **8**=83, **9**=93

Voltage – **20**=208V, **24**=240V, **48**=480V, **60**=600V

Capacitor type – **C**=Individual, **F**=Fixed bank, **P**=Pump jack

Individual capacitors

3 phase ①

240 Volt, 60 Hz



ABB's standard capacitor is suitable for general power factor correction applications, for connection directly at the reactive source. Features include:

- Dry, environmentally safe construction
- Self healing capability
- Patented Internal Protected Elements
- NEMA 1, 3R, 12
- Easy electrical connection to large terminals
- Convenient grounding lug
- Mounting feet for easy installation
- Suitable for floor or wall mounting

240 Volt, 60 Hz – 3-Phase

Enclosure size	kvar rating	Rated current per phase (amps)	Approx. shipping weight (lbs.)	Enclosure type					
				Indoor – NEMA 1		Outdoor – NEMA 3R		Indoor – NEMA 12	
				Catalog number	List price	Catalog number	List price	Catalog number	List price
43	1	2.4	8	C244G1	\$ 268	C244R1	\$ 288	C244D1	\$ 288
	1.5	3.6	8	C244G1.5	278	C244R1.5	300	C244D1.5	300
	2	4.8	8	C244G2	288	C244R2	310	C244D2	310
	2.5	6.0	8	C244G2.5	322	C244R2.5	342	C244D2.5	342
	3	7.2	8	C244G3	336	C244R3	358	C244D3	358
	3.5	8.4	8	C244G3.5	354	C244R3.5	374	C244D3.5	374
	4	9.6	8	C244G4	386	C244R4	406	C244D4	406
	5	12.0	8	C244G5	406	C244R5	428	C244D5	428
	6	14.4	8	C244G6	450	C244R6	470	C244D6	470
	7	16.8	8	C244G7	514	C244R7	536	C244D7	536
	7.5	18.0	8	C244G7.5	524	C244R7.5	546	C244D7.5	546
	8	19.2	8	C244G8	536	C244R8	556	C244D8	556
	9	21.7	8	C244G9	556	C244R9	578	C244D9	578
	10	24.1	8	C244G10	578	C244R10	600	C244D10	600
	11	26.5	13	C244G11	610	C244R11	632	C244D11	632
	12	28.9	13	C244G12	664	C244R12	684	C244D12	684
	12.5	30.1	13	C244G12.5	684	C244R12.5	706	C244D12.5	706
	14	33.7	8	C244G14	706	C244R14	728	C244D14	728
	15	36.1	8	C244G15	750	C244R15	770	C244D15	770
	17	40.8	22	C244G17	814	C244R17	836	C244D17	826
20	48.1	22	C244G20	898	C244R20	920	C244D20	920	
53	22.5	54.1	23	C245G22.5	942	C245R22.5	964	C245D22.5	964
	25	60.1	23	C245G25	1,006	C245R25	1,028	C245D25	1,028
	30	72.2	23	C245G30	1,112	C245R30	1,134	C245D30	1,134
	35	84.2	25	C245G35	1,220	C245R35	1,242	C245D35	1,242
	40	96.2	25	C245G40	1,392	C245R40	1,412	C245D40	1,412
63	45	108.3	34	C246G45	1,626	C246R45	1,648	C246D45	1,648
	50	120.3	34	C246G50	1,776	C246R50	1,798	C246D50	1,798
	55	132.3	37	C246G55	2,248	C246R55	2,268	C246D55	2,268
	60	144.3	37	C246G60	2,354	C246R60	2,376	C246D60	2,376
	70	168.4	39	C246G70	2,596	C246R70	2,618	C246D70	2,618
	80	192.6	43	C246G80	2,870	C246R80	2,892	C246D80	2,892

Capacitor state indication system

240V kvar	LEDs catalog number suffix	List price
1 – 15		\$ 182
17 – 30	-2LE	204
35 – 60	-2LF	226
70 – 80		450

The capacitor state indication system consists of two yellow LED lights which illuminate only when the capacitor is energized and functioning at 65% or more of its rated kvar capacity.

The two light system will indicate a failure in any one of the three phases of the capacitor.

208 Volt availability

For 208 volt applications, derate the 240V capacitors. The kvar at 208V will be .75 times the kvar at 240V.

NOTE: ABB's patented IPE design eliminates the need for additional overcurrent protection when capacitors are electrically connected on the load side of a motor starter circuit breaker or fusible disconnect switch.

Optional mounting for individual capacitors

Type	Enclosure sizes	Catalog number	List price
Wall mounting kit ②	43-93	WM83K	\$ 54
Rack mounting style enclosure	53-93	Catalog # suffix -RM	74

① For single phase capacitors, please consult your ABB representative.

② When the wall mounting kit is used with enclosure sizes 63, 83 & 93, it is recommended to order the rack style enclosure.

Individual capacitors

3-phase ①

480 Volt, 60 Hz

480 Volt, 60 Hz – 3-Phase

Enclosure size	kvar rating	Rated current per phase (amps)	Approx. shipping weight (lbs.)	Enclosure type					
				Indoor – NEMA 1		Outdoor – NEMA 3R		Indoor – NEMA 12	
				Catalog number	List price	Catalog number	List price	Catalog number	List price
43	1.5	1.8	8	C484G1.5	\$ 268	C484R1.5	\$ 288	C484D1.5	\$ 288
	2	2.4	8	C484G2	278	C484R2	300	C484D2	300
	2.5	3.0	8	C484G2.5	288	C484R2.5	310	C484D2.5	310
	3	3.6	8	C484G3	300	C484R3	322	C484D3	322
	4	4.8	8	C484G4	304	C484R4	326	C484D4	326
	5	6.0	8	C484G5	322	C484R5	342	C484D5	342
	6	7.2	8	C484G6	342	C484R6	364	C484D6	364
	7.5	9.0	8	C484G7.5	374	C484R7.5	396	C484D7.5	396
	8	9.6	8	C484G8	386	C484R8	406	C484D8	406
	9	10.8	8	C484G9	406	C484R9	428	C484D9	428
	10	12.0	8	C484G10	428	C484R10	450	C484D10	450
	12	14.4	13	C484G12	450	C484R12	470	C484D12	470
	12.5	15.0	13	C484G12.5	460	C484R12.5	482	C484D12.5	482
	13	15.6	13	C484G13	482	C484R13	502	C484D13	502
	13.5	16.2	13	C484G13.5	492	C484R13.5	514	C484D13.5	514
	14	16.8	8	C484G14	502	C484R14	524	C484D14	524
	15	18.0	8	C484G15	514	C484R15	536	C484D15	536
	16	19.2	13	C484G16	524	C484R16	546	C484D16	546
	17	20.4	13	C484G17	536	C484R17	556	C484D17	556
	17.5	21.0	13	C484G17.5	546	C484R17.5	568	C484D17.5	568
	18	21.7	13	C484G18	556	C484R18	578	C484D18	578
	19	22.8	13	C484G19	568	C484R19	588	C484D19	588
	20	24.1	13	C484G20	588	C484R20	610	C484D20	610
	21	25.3	13	C484G21	620	C484R21	642	C484D21	642
	22	26.5	13	C484G22	632	C484R22	652	C484D22	652
	22.5	27.1	13	C484G22.5	642	C484R22.5	664	C484D22.5	664
	24	28.9	13	C484G24	664	C484R24	684	C484D24	684
	25	30.1	13	C484G25	674	C484R25	696	C484D25	696
	27	32.5	13	C484G27	706	C484R27	728	C484D27	728
	30	36.1	13	C484G30	738	C484R30	760	C484D30	760
53	32.5	39.1	14	C485G32.5	770	C485R32.5	792	C485D32.5	792
	35	42.1	23	C485G35	824	C485R35	846	C485D35	846
	37.5	45.1	23	C485G37.5	856	C485R37.5	878	C485D37.5	878
	40	48.1	23	C485G40	888	C485R40	910	C485D40	910
	42.5	51.1	23	C485G42.5	920	C485R42.5	942	C485D42.5	942
	45	54.1	25	C485G45	952	C485R45	974	C485D45	974
	47.5	57.1	25	C485G47.5	974	C485R47.5	996	C485D47.5	996
50	60.1	25	C485G50	984	C485R50	1,006	C485D50	1,006	
63	52.5	63.1	37	C486G52.5	1,028	C486R52.5	1,048	C486D52.5	1,048
	55	66.2	37	C486G55	1,060	C486R55	1,080	C486D55	1,080
	57.5	69.2	37	C486G57.5	1,102	C486R57.5	1,124	C486D57.5	1,124
	60	72.2	37	C486G60	1,124	C486R60	1,144	C486D60	1,144
	62.5	75.2	37	C486G62.5	1,156	C486R62.5	1,178	C486D62.5	1,178
	65	78.2	37	C486G65	1,198	C486R65	1,220	C486D65	1,220
	70	84.2	39	C486G70	1,242	C486R70	1,262	C486D70	1,262
	75	90.2	39	C486G75	1,370	C486R75	1,392	C486D75	1,392
77.5	93.2	39	C486G77.5	1,456	C486R77.5	1,476	C486D77.5	1,476	
83	80	96.2	56	C488G80	1,498	C488R80	1,520	C488D80	1,520
	85	102.2	56	C488G85	1,584	C488R85	1,606	—	—
	87.5	105.2	56	C488G87.5	1,670	C488R87.5	1,690	C488D87.5	1,690
	90	108.3	56	C488G90	1,744	C488R90	1,766	C488D90	1,766
	95	114.3	56	C488G95	1,808	C488R95	1,830	C488D95	1,830
	100	120.3	56	C488G100	1,840	C488R100	1,862	C488D100	1,862
	105	126.3	59	C488G105	2,060	C488R105	2,082	C488D105	2,082
	110	132.3	61	C488G110	2,066	C488R110	2,106	C488D110	2,186
	115	138.3	76	C488G115	2,210	C488R115	2,232	C488D115	2,232
	120	144.3	76	C488G120	2,256	C488R120	2,278	C488D120	2,278

Mounting options

For mounting options, see page 20.9. Base mounting is standard.

NOTE: ABB's patented IPE design eliminates the need for additional overcurrent protection when capacitors are electrically connected on the load side of a motor starter circuit breaker or fusible disconnect switch.

21 Capacitor state indication

See page 20.10.

① For single phase capacitors, please consult your ABB representative.

Individual capacitors

3 phase ①

600 Volt, 60 Hz

Low Voltage
Network Quality

600 Volt, 60 Hz – 3 phase

Enclosure size	kvar rating	Rated current per phase (amps)	Approx. shipping weight (lbs.)	Enclosure type					
				Indoor – NEMA 1		Outdoor – NEMA 3R		Indoor – NEMA 12	
				Catalog number	List price	Catalog number	List price	Catalog number	List price
43	2.2	1.9	8	C604G2.2	\$ 288	C604R2.2	\$ 310	C604D2.2	310
	3	2.9	8	C604G3	300	C604R3	322	C604D3	322
	4	3.8	8	C604G4	310	C604R4	332	C604D4	332
	5	4.8	8	C604G5	332	C604R5	354	C604D5	354
	7.5	7.2	8	C604G7.5	406	C604R7.5	428	C604D7.5	428
	10	9.6	8	C604G10	450	C604R10	470	C604D10	470
	14	13.5	8	C604G14	492	C604R14	514	C604D14	514
	15	14.4	8	C604G15	502	C604R15	524	C604D15	524
	17.5	16.8	13	C604G17.5	578	C604R17.5	600	C604D17.5	600
	20	19.2	13	C604G20	610	C604R20	632	C604D20	632
	25	24.1	13	C604G25	664	C604R25	684	C604D25	684
30	28.9	13	C604G30	728	C604R30	750	C604D30	750	
53	35	33.7	25	C605G35	834	C605R35	856	C605D35	856
	40	38.5	25	C605G40	898	C605R40	920	C605D40	920
	45	43.3	25	C605G45	984	C605R45	1,006	C605D45	1,006
	50	48.1	35	C605G50	1,070	C605R50	1,092	C605D50	1,092
63	60	57.7	37	C606G60	1,178	C606R60	1,198	C606D60	1,198
	70	67.4	39	C606G70	1,284	C606R70	1,306	C606D70	1,306
	75	72.2	39	C606G75	1,392	C606R75	1,412	C606D75	1,412
	80	77.0	39	C606G80	1,540	C606R80	1,562	C606D80	1,562
83	90	86.6	54	C608G90	1,754	C608R90	1,776	C608D90	1,776
	95	91.4	54	C608G95	1,820	C608R95	1,840	C608D95	1,840
	100	96.2	56	C608G100	1,926	C608R100	1,948	C608D100	1,948
	105	101.0	59	C608G105	1,984	C608R105	2,006	C608D105	2,006
	110	105.8	61	C608G110	2,100	C608R110	2,122	C608D110	2,122
	115	110.7	76	C608G115	2,148	C608R115	2,170	C608D115	2,170
	120	115.5	76	C608G120	2,184	C608R120	2,206	C608D120	2,206
	125	120.3	76	C608G125	2,550	C608R125	2,572	C608D125	2,572
	130	125.1	76	C608G130	2,684	C608R130	2,706	C608D130	2,706
	135	129.9	76	C608G135	2,710	C608R135	2,732	C608D135	2,732

Capacitor state indication system

480V & 600V kvar	LEDs catalog number suffix	List price
1 – 30		\$ 182
32.5 – 60	-2LE	204
62.5 – 100	-2LF	224
105 – 135		450

The capacitor state indication system consists of two yellow LED lights which illuminate only when the capacitor is energized and functioning at 65% or more of its rated kvar capacity.

The two light system will indicate a failure in any one of the three phases of the capacitor.

Mounting options

For mounting options, see page 20.9. Base mounting is standard.

NOTE: ABB's patented IPE design eliminates the need for additional overcurrent protection when capacitors are electrically connected on the load side of a motor starter circuit breaker or fusible disconnect switch.

① For single phase capacitors, please consult your ABB representative

Individual capacitors with fuses and blown fuse indicators, 3 phase 240 Volt, 60 Hz



ABB low voltage capacitors are fully protected by the three levels of protection offered by the patented Sequential Protection System which includes dry self-healing capacitors, internally protected elements and the dry non-flammable vermiculite filler. However, some users have traditionally requested external fuses and blown fuse indicators, so these modified units are offered for those applications.

Features include:

- Dry, environmentally safe construction
- Self healing capability
- Patented Internal Protected Elements
- NEMA 1, 3R, 12
- Easy electrical connection to large terminals
- Convenient grounding lug
- Mounting feet for easy installation
- Suitable for floor or wall mounting
- Includes three fuses and three blown fuse indication lamps

240 Volt, 60 Hz — 3 phase

Enclosure size	kvar rating	Rated current per phase (amps)	Fuse amps/type	Approx. shipping weight (lbs.)	Enclosure type					
					Indoor – NEMA 1		Outdoor – NEMA 3R		Indoor – NEMA 12	
					Catalog number	List price	Catalog number	List price	Catalog number	List price
43	1	2.4	6/CC	8	C244G1-3FI	\$ 406	C244R1-3FI	\$ 428	C244D1-3FI	\$ 428
	1.5	3.6	10/CC	8	C244G1.5-3FI	438	C244R1.5-3FI	460	C244D1.5-3FI	460
	2	4.8	12/CC	8	C244G2-3FI	450	C244R2-3FI	470	C244D2-3FI	470
	2.5	6.0	15/CC	8	C244G2.5-3FI	460	C244R2.5-3FI	482	C244D2.5-3FI	482
	3	7.2	20/CC	8	C244G3-3FI	470	C244R3-3FI	492	C244D3-3FI	492
	3.5	8.4	20/CC	8	C244G3.5-3FI	492	C244R3.5-3FI	514	C244D3.5-3FI	514
	4	9.6	25/CC	8	C244G4-3FI	536	C244R4-3FI	556	C244D4-3FI	558
	5	12.0	30/CC	8	C244G5-3FI	578	C244R5-3FI	600	C244D5-3FI	600
	6	14.4	45/T	8	C244G6-3FI	600	C244R6-3FI	620	C244D6-3FI	620
	7	16.8	50/T	8	C244G7-3FI	642	C244R7-3FI	664	C244D7-3FI	664
	7.5	18.0	60/T	8	C244G7.5-3FI	664	C244R7.5-3FI	684	C244D7.5-3FI	684
	8	19.2	60/T	8	C244G8-3FI	706	C244R8-3FI	728	C244D8-3FI	728
	9	21.7	50/KGJ	14	C245G9-3FI	750	C245R9-3FI	770	C245D9-3FI	770
	10	24.1	50/KGJ	14	C245G10-3FI	792	C245R10-3FI	814	C245D10-3FI	814
11	26.5	60/KGJ	14	C245G11-3FI	834	C245R11-3FI	856	C245D11-3FI	856	
12	28.9	60/KGJ	14	C245G12-3FI	898	C245R12-3FI	920	C245D12-3FI	920	
12.5	30.1	60/KGJ	14	C245G12.5-3FI	942	C245R12.5-3FI	964	C245D12.5-3FI	964	
14	33.7	75/KGJ	14	C245G14-3FI	984	C245R14-3FI	1,006	C245D14-3FI	1,006	
53	15	36.1	80/KGJ	14	C246G15-3FI	1,006	C246R15-3FI	1,028	C246D15-3FI	1,028
	17	40.9	80/KGJ	23	C246G17-3FI	1,112	C246R17-3FI	1,134	C246D17-3FI	1,134
	20	48.1	125/KGJ	23	C246G20-3FI	1,178	C246R20-3FI	1,198	C246D20-3FI	1,198
	22.5	54.2	125/KGJ	23	C246G22.5-3FI	1,284	C246R22.5-3FI	1,306	C246D22.5-3FI	1,306
	25	60.1	150/KGJ	23	C246G25-3FI	1,392	C246R25-3FI	1,412	C246D25-3FI	1,412
	30	72.2	175/KGJ	23	C246G30-3FI	1,606	C246R30-3FI	1,626	C246D30-3FI	1,626
	35	84.2	200/KGJ	23	C246G35-3FI	1,766	C246R35-3FI	1,786	C246D35-3FI	1,786
	40	96.2	225/KGJ	25	C246G40-3FI	2,034	C246R40-3FI	2,054	C246D40-3FI	2,054
63	45	108.3	250/KGJ	34	C248G45-3FI	2,248	C248R45-3FI	2,268	C248D45-3FI	2,268
	50	120.3	250/KGJ	34	C248G50-3FI	2,462	C248R50-3FI	2,482	C248D50-3FI	2,482
	55	132	250/KGJ	37	C248G55-3FI	2,622	C248R55-3FI	2,642	C248D55-3FI	2,642
	60	144.3	250/KGJ	37	C248G60-3FI	2,836	C248R60-3FI	2,856	C248D60-3FI	2,856

208 Volt availability

For 208 volt applications, derate the 240V capacitors. The kvar at 208V will be .75 times the kvar at 240V.

NOTE: ABB's patented IPE design eliminates the need for additional

overcurrent protection when capacitors are electrically connected on the load side of a motor starter circuit breaker or fusible disconnect switch.

Optional mounting for individual capacitors

Type	Enclosure sizes	Catalog number	List price
Wall mounting kit ②	43-93	WM83K	\$ 54
Rack mounting style enclosure	53-93	Catalog # suffix -RM	74

② When the wall mounting kit is used with enclosure sizes 63, 83 & 93, it is recommended to order the rack style enclosure.

Individual capacitors with fuses and blown fuse indicators, 3 phase 480 Volt, 60 Hz

**Low Voltage
Network Quality**

480 Volt, 60 Hz – 3 phase

Enclosure size	kvar rating	Rated current per phase (amps)	Fuse amps/type	Approx. shipping weight (lbs.)	Enclosure type					
					Indoor – NEMA 1		Outdoor – NEMA 3R		Indoor – NEMA 12	
					Catalog number	List price	Catalog number	List price	Catalog number	List price
43	1.5	1.8	5/CC	8	C484G1.5-3FI	\$ 418	C484R1.5-3FI	\$ 438	C484D1.5-3FI	\$ 438
	2	2.4	6/CC	8	C484G2-3FI	422	C484R2-3FI	442	C484D2-3FI	442
	2.5	3.0	8/CC	8	C484G2.5-3FI	428	C484R2.5-3FI	450	C484D2.5-3FI	450
	3	3.6	10/CC	8	C484G3-3FI	432	C484R3-3FI	454	C484D3-3FI	454
	4	4.8	12/CC	8	C484G4-3FI	438	C484R4-3FI	460	C484D4-3FI	460
	5	6.0	15/CC	8	C484G5-3FI	442	C484R5-3FI	464	C484D5-3FI	464
	6	7.2	20/CC	8	C484G6-3FI	460	C484R6-3FI	482	C484D6-3FI	482
	7.5	9.0	25/CC	8	C484G7.5-3FI	514	C484R7.5-3FI	536	C484D7.5-3FI	536
	8	9.6	25/CC	8	C484G8-3FI	546	C484R8-3FI	568	C484D8-3FI	568
	9	10.8	30/CC	8	C484G9-3FI	568	C484R9-3FI	588	C484D9-3FI	588
	10	12.0	30/CC	8	C484G10-3FI	588	C484R10-3FI	610	C484D10-3FI	610
	12	14.4	45/T	13	C484G12-3FI	600	C484R12-3FI	620	C484D12-3FI	620
	12.5	15.0	45/T	13	C484G12.5-3FI	610	C484R12.5-3FI	632	C484D12.5-3FI	632
	13	15.6	50/T	13	C484G13-3FI	620	C484R13-3FI	642	C484D13-3FI	642
	13.5	16.2	50/T	13	C484G13.5-3FI	624	C484R13.5-3FI	646	C484D13.5-3FI	646
	14	16.8	50/T	8	C484G14-3FI	632	C484R14-3FI	652	C484D14-3FI	652
15	18.0	60/T	8	C484G15-3FI	652	C484R15-3FI	674	C484D15-3FI	674	
16	19.2	60/T	13	C484G16-3FI	664	C484R16-3FI	684	C484D16-3FI	684	
53	17	20.4	50/KGJ	14	C485G17-3FI	684	C485R17-3FI	706	C485D17-3FI	706
	17.5	21.0	50/KGJ	14	C485G17.5-3FI	706	C485R17.5-3FI	728	C485D17.5-3FI	728
	18	21.7	50/KGJ	14	C485G18-3FI	728	C485R18-3FI	750	C485D18-3FI	750
	19	22.8	50/KGJ	14	C485G19-3FI	750	C485R19-3FI	770	C485D19-3FI	770
	20	24.1	50/KGJ	14	C485G20-3FI	770	C485R20-3FI	792	C485D20-3FI	792
	21	25.3	60/KGJ	14	C485G21-3FI	782	C485R21-3FI	802	C485D21-3FI	802
	22	26.5	60/KGJ	14	C485G22-3FI	792	C485R22-3FI	814	C485D22-3FI	814
	22.5	27.1	60/KGJ	14	C485G22.5-3FI	814	C485R22.5-3FI	834	C485D22.5-3FI	834
	24	28.9	60/KGJ	14	C485G24-3FI	834	C485R24-3FI	856	C485D24-3FI	856
	25	30.1	75/KGJ	14	C485G25-3FI	856	C485R25-3FI	878	C485D25-3FI	878
27	32.5	75/KGJ	14	C485G27-3FI	898	C485R27-3FI	920	C485D27-3FI	920	
63	30	36.1	80/KGJ	14	C486G30-3FI	964	C486R30-3FI	984	C486D30-3FI	984
	32.5	39.1	100/KGJ	14	C486G32.5-3FI	1,016	C486R32.5-3FI	1,038	C486D32.5-3FI	1,038
	35	42.1	100/KGJ	23	C486G35-3FI	1,070	C486R35-3FI	1,092	C486D35-3FI	1,092
	37.5	45.1	100/KGJ	23	C486G37.5-3FI	1,092	C486R37.5-3FI	1,112	C486D37.5-3FI	1,112
	40	48.1	125/KGJ	23	C486G40-3FI	1,112	C486R40-3FI	1,134	C486D40-3FI	1,134
	42.5	51.1	125/KGJ	23	C486G42.5-3FI	1,178	C486R42.5-3FI	1,198	C486D42.5-3FI	1,198
	45	54.1	125/KGJ	25	C486G45-3FI	1,242	C486R45-3FI	1,262	C486D45-3FI	1,262
	47.5	57.1	125/KGJ	25	C486G47.5-3FI	1,284	C486R47.5-3FI	1,306	C486D47.5-3FI	1,306
	50	60.1	150/KGJ	25	C486G50-3FI	1,326	C486R50-3FI	1,348	C486D50-3FI	1,348
83	52.5	63.1	150/KGJ	37	C488G52.5-3FI	1,370	C488R52.5-3FI	1,392	C488D52.5-3FI	1,392
	55	66.2	150/KGJ	37	C488G55-3FI	1,412	C488R55-3FI	1,434	C488D55-3FI	1,434
	57.5	69.2	150/KGJ	37	C488G57.5-3FI	1,456	C488R57.5-3FI	1,476	C488D57.5-3FI	1,476
	60	72.2	175/KGJ	37	C488G60-3FI	1,476	C488R60-3FI	1,498	C488D60-3FI	1,498
	62.5	75.2	175/KGJ	37	C488G62.5-3FI	1,530	C488R62.5-3FI	1,552	C488D62.5-3FI	1,552
	65	78.2	175/KGJ	37	C488G65-3FI	1,540	C488R65-3FI	1,562	C488D65-3FI	1,562
	70	84.2	200/KGJ	39	C488G70-3FI	1,584	C488R70-3FI	1,606	C488D70-3FI	1,606
	75	90.2	200/KGJ	41	C488G75-3FI	1,626	C488R75-3FI	1,648	C488D75-3FI	1,648
77.5	93.2	200/KGJ	41	C488G77.5-3FI	1,658	C488R77.5-3FI	1,680	C488D77.5-3FI	1,680	
93	80	96.2	225/KGJ	56	C489G80-3FI	1,712	C489R80-3FI	1,734	C489D80-3FI	1,734
	85	102.2	225/KGJ	56	C489G85-3FI	1,820	C489R85-3FI	1,840	C489D85-3FI	1,840
	87.5	105.2	225/KGJ	56	C489G87.5-3FI	1,872	C489R87.5-3FI	1,894	C489D87.5-3FI	1,894
	90	108.3	225/KGJ	56	C489G90-3FI	1,926	C489R90-3FI	1,948	C489D90-3FI	1,948
	95	114.3	250/KGJ	56	C489G95-3FI	2,000	C489R95-3FI	2,022	C489D95-3FI	2,022
	100	120.3	250/KGJ	56	C489G100-3FI	2,066	C489R100-3FI	2,086	C489D100-3FI	2,086
	105	126.3	250/KGJ	59	C489G105-3FI	2,752	C489R105-3FI	2,774	C489D105-3FI	2,774
	110	132.3	250/KGJ	61	C489G110-3FI	2,820	C489R110-3FI	2,842	C489D110-3FI	2,842
	115	138.3	250/KGJ	76	C489G115-3FI	2,902	C489R115-3FI	2,924	C489D115-3FI	2,924
120	144.3	300/KGJ	76	C489G120-3FI	2,990	C489R120-3FI	3,012	C489D120-3FI	3,012	

NOTE: ABB's patented IPE design eliminates the need for additional overcurrent protection when capacitors are electrically connected on the load side of a motor starter circuit breaker or fusible disconnect switch.

Mounting options

For mounting options, see page 20.12. Base mounting is standard.

Individual capacitors with fuses and blown fuse indicators, 3 phase 600 Volt, 60 Hz

600 Volt, 60 Hz – 3 phase

Enclosure size	kvar rating	Rated current per phase (amps)	Fuse amps/type	Approx. shipping weight (lbs.)	Enclosure type					
					Indoor – NEMA 1		Outdoor – NEMA 3R		Indoor – NEMA 12	
					Catalog number	List price	Catalog number	List price	Catalog number	List price
43	2.2	2.1	6/CC	8	C604G2.2-3FI	\$ 450	C604R2.2-3FI	\$ 470	C604D2.2-3FI	\$ 470
	3	2.9	8/CC	8	C604G3-3FI	460	C604R3-3FI	482	C604D3-3FI	482
	4	3.8	10/CC	8	C604G4-3FI	470	C604R4-3FI	492	C604D4-3FI	492
	5	4.8	12/CC	8	C604G5-3FI	492	C604R5-3FI	514	C604D5-3FI	514
	7.5	7.2	20/CC	8	C604G7.5-3FI	556	C604R7.5-3FI	578	C604D7.5-3FI	578
	10	9.6	25/CC	8	C604G10-3FI	600	C604R10-3FI	620	C604D10-3FI	620
	14	13.5	40/T	13	C604G14-3FI	632	C604R14-3FI	652	C604D14-3FI	652
	15	14.4	45/T	13	C604G15-3FI	664	C604R15-3FI	684	C604D15-3FI	684
	17.5	16.8	50/T	13	C604G17.5-3FI	750	C604R17.5-3FI	770	C604D17.5-3FI	772
	20	19.2	60/T	13	C604G20-3FI	856	C604R20-3FI	878	C604D20-3FI	878
53	25	24.1	50/KGJ	14	C605G25-3FI	898	C605R25-3FI	920	C605D25-3FI	920
	30	28.9	60/KGJ	14	C605G30-3FI	1,006	C605R30-3FI	1,028	C605D30-3FI	1,028
63	35	33.7	75/KGJ	25	C606G35-3FI	1,112	C606R35-3FI	1,134	C606D35-3FI	1,134
	40	38.5	80/KGJ	25	C606G40-3FI	1,230	C606R40-3FI	1,252	C606D40-3FI	1,252
	45	43.3	100/KGJ	25	C606G45-3FI	1,284	C606R45-3FI	1,306	C606D45-3FI	1,306
	50	48.1	125/KGJ	35	C606G50-3FI	1,392	C606R50-3FI	1,412	C606D50-3FI	1,412
83	60	57.7	125/KGJ	37	C608G60-3FI	1,498	C608R60-3FI	1,520	C608D60-3FI	1,520
	70	67.4	150/KGJ	39	C608G70-3FI	1,606	C608R70-3FI	1,626	C608D70-3FI	1,626
	75	72.3	175/KGJ	39	C608G75-3FI	1,658	C608R75-3FI	1,680	C608D75-3FI	1,680
	80	77.0	175/KGJ	39	C608G80-3FI	1,820	C608R80-3FI	1,840	C608D80-3FI	1,840
93	90	86.6	200/KGJ	56	C609G90-3FI	2,000	C609R90-3FI	2,022	C609D90-3FI	2,022
	95	91.4	200/KGJ	56	C609G95-3FI	2,044	C609R95-3FI	2,066	C609D95-3FI	2,066
	100	96.2	225/KGJ	56	C609G100-3FI	2,086	C609R100-3FI	2,108	C609D100-3FI	2,108
	105	101.0	250/KGJ	59	C609G105-3FI	2,842	C609R105-3FI	2,864	C609D105-3FI	2,864
	110	105.8	250/KGJ	61	C609G110-3FI	2,922	C609R110-3FI	2,944	C609D110-3FI	2,944
	115	110.7	250/KGJ	76	C609G115-3FI	3,020	C609R115-3FI	3,042	C609D115-3FI	3,042
	120	115.5	250/KGJ	76	C609G120-3FI	3,096	C609R120-3FI	3,096	C609D120-3FI	3,118
	125	120.3	250/KGJ	76	C609G125-3FI	3,376	C609R125-3FI	3,398	C609D125-3FI	3,398
	130	125.1	250/KGJ	76	C609G130-3FI	3,516	C609R130-3FI	3,538	C609D130-3FI	3,538
	135	129.1	250/KGJ	76	C609G135-3FI	3,548	C609R135-3FI	3,570	C609D135-3FI	3,570

NOTE: ABB's patented IPE design eliminates the need for additional overcurrent protection when capacitors are electrically connected on the load side of a motor starter circuit breaker or fusible disconnect switch.

Mounting options

For mounting options, see page 20.12. Base mounting is standard.

Individual capacitors Pump jack 240 & 480 Volt, 60 Hz



The CLMD-PJ capacitor is ideally suited for oil-field pumping units and other outdoor applications. Standard features include:

- Outdoor, weatherproof enclosure
- 4 feet of 10 gauge, 4-conductor wire for ease of installation
- Convenient pole-mounting design
- Lightweight, totally dry construction

Steel enclosure – 240 Volt, 60 Hz, 3 phase

Enclosure size	kvar rating	Approx. weight (lbs.)	Catalog number	List price
43	2.5	8	P244R2.5	\$ 438
	3.5	8	P244R3.5	482
	5	8	P244R5	546
	10	8	P244R10	610
	12.5	13	P244R12.5	728
	14	8	P244R14	824
	15	8	P244R15	866

208 Volt availability

For 208 volt applications, derate the 240V capacitors. The kvar at 208V will be .75 times the kvar at 240V.

Steel enclosure – 480 Volt, 60 Hz, 3 phase

Enclosure size	kvar rating	Approx. weight (lbs.)	Catalog number	List price
43	1.5	8	P484R1.5	\$ 386
	2	8	P484R2	396
	3	8	P484R3	418
	4	8	P484R4	438
	5	8	P484R5	460
	6	8	P484R6	482
	7.5	8	P484R7.5	492
	10	8	P484R10	514
	15	8	P484R15	578
	20	13	P484R20	738
	21	13	P484R21	760
	22.5	13	P484R22.5	802
	25	13	P484R25	846
	27	13	P484R27	888
	30	13	P484R30	952

NOTE: ABB's patented IPE design eliminates the need for additional overcurrent protection when capacitors are electrically connected on the load side of a motor starter circuit breaker or fusible disconnect switch.

Individual capacitors

Type CLMD-13

208, 240, 480 & 600 Volt, 60 Hz



The CLMD-13 capacitor is ideally suited for use in motor control centers, control panels and other indoor applications. Standard features include:

- Indoor, steel enclosure
- Easy electrical connection by means of a terminal block mounted on top of the capacitor enclosure (#4 — #18GA)
- Convenient ground lug mounted on top of the capacitor enclosure
- Mounting feet for easy installation
- Lightweight, small dimensions, totally dry construction
- Options and accessories include remote state indication

208 Volt, 60 Hz, 3 phase

Enclosure size	kvar rating	Rated current per phase (amps)	Approx. shipping weight (lbs)	Enclosure type	
				Indoor — NEMA 1	
				Catalog number	List price
13	0.8	2.2	6	C201G0.8	\$ 246
	1.1	3.1	6	C201G1.1	256
	2	5.6	6	C201G2	300
	2.5	6.9	6	C201G2.5	322
	3	8.3	6	C201G3	354
	4	11.1	6	C201G4	396
	5	13.9	6	C201G5	482
	7.5	20.8	6	C201G7.5	546

600 Volt, 60 Hz, 3 phase

Enclosure size	kvar rating	Rated current per phase (amps)	Approx. shipping weight (lbs)	Enclosure type	
				Indoor — NEMA 1	
				Catalog number	List price
13	2	1.9	6	C601G2	\$ 288
	3	2.9	6	C601G3	300
	4	3.8	6	C601G4	310
	5	4.8	6	C601G5	332
	7.5	7.2	6	C601G7.5	354
	10	9.6	6	C601G10	386
	15	14.4	6	C601G15	438

240 Volt, 60 Hz, 3 phase

Enclosure size	kvar rating	Rated current per phase (amps)	Approx. shipping weight (lbs)	Enclosure type	
				Indoor — NEMA 1	
				Catalog number	List price
13	1	2.4	6	C241G1	\$ 236
	1.5	3.6	6	C241G1.5	246
	2	4.8	6	C241G2	256
	2.5	6.0	6	C241G2.5	288
	3.5	8.4	6	C241G3.5	322
	5	12.0	6	C241G5	342
	7.5	18.0	6	C241G7.5	438
	10	24.1	6	C241G10	514

Options

Type	Catalog number suffix ①	List price adder
Remote state indication two LEDs	-2L	\$ 130

NOTE: ABB's patented IPE design eliminates the need for additional overcurrent protection when capacitors are electrically connected on the load side of a motor starter circuit breaker or fusible disconnect switch.

480 Volt, 60 Hz, 3 phase

Enclosure size	kvar rating	Rated current per phase (amps)	Approx. shipping weight (lbs)	Enclosure type	
				Indoor — NEMA 1	
				Catalog number	List price
13	0.9	1.1	6	C481G0.9	\$ 236
	1.5	1.8	6	C481G1.5	256
	2	2.4	6	C481G2	268
	2.5	3.0	6	C481G2.5	278
	3.5	4.2	6	C481G3.5	310
	4	4.8	6	C481G4	314
	5	6.0	6	C481G5	332
	6	7.2	6	C481G6	342
	7.5	9.0	6	C481G7.5	354
	8	9.6	6	C481G8	364
	9	10.8	6	C481G9	374
	10	12.0	6	C481G10	386
	14	16.8	6	C481G14	406
	15	18.0	6	C481G15	428
	17	20.4	6	—	—

① Add suffix to end of catalog number.

Individual capacitors Type CLMD-13SC, Stud connected 208, 240, 480 & 600 Volt, 60 Hz



The CLMD-13SC (Stud Connected) capacitor is ideally suited for use in motor control centers, control panels and other indoor applications. Standard features include:

- Indoor, steel enclosure with cover
- Three stud terminals for electrical connection or capacitor parallel bus bar connection
- Mounting feet for easy capacitor installation
- Lightweight, small dimensions, totally dry construction

208 Volt, 60 Hz, 3 phase

Enclosure size	kvar rating	Rated current per phase (amps)	Approx. shipping weight (lbs)	Enclosure type	
				Indoor — NEMA 1	
				Catalog number	List price
13	0.8	2.2	6	C201G0.8SC	\$ 272
	1.1	3.1	6	—	—
	2	5.6	6	—	—
	2.5	6.9	6	C201G2.5SC	326
	3	8.3	6	—	—
	4	11.1	6	C201G4SC	422
	5	13.9	6	C201G5SC	508
	7.5	20.8	6	C201G7.5SC	572

600 Volt, 60 Hz, 3 phase

Enclosure size	kvar rating	Rated current per phase (amps)	Approx. shipping weight (lbs)	Enclosure type	
				Indoor — NEMA 1	
				Catalog number	List price
13	2	1.9	6	C601G2SC	\$ 294
	3	2.9	6	C601G3SC	326
	4	3.8	6	C601G4SC	336
	5	4.8	6	C601G5SC	358
	7.5	7.2	6	C601G7.5SC	378
	10	9.6	6	C601G10SC	410
	15	14.4	6	C601G15SC	464

NOTE: ABB's patented IPE design eliminates the need for additional overcurrent protection when capacitors are electrically connected on the load side of a motor starter circuit breaker or fusible disconnect switch.

240 Volt, 60 Hz, 3 phase

Enclosure size	kvar rating	Rated current per phase (amps)	Approx. shipping weight (lbs)	Enclosure type	
				Indoor — NEMA 1	
				Catalog number	List price
13	1	2.4	6	C241G1SC	\$ 262
	1.5	3.6	6	C241G1.5SC	294
	2	4.8	6	C241G2SC	304
	2.5	6.0	6	C241G2.5SC	314
	3.5	8.4	6	C241G3.5SC	346
	5	12.0	6	C241G5SC	368
	7.5	18.0	6	C241G7.5SC	464
	10	24.1	6	C241G10SC	540

480 Volt, 60 Hz, 3 phase

Enclosure size	kvar rating	Rated current per phase (amps)	Approx. shipping weight (lbs)	Enclosure type	
				Indoor — NEMA 1	
				Catalog number	List price
13	0.9	1.1	6	C481G0.9SC	\$ 262
	1.5	1.8	6	C481G1.5SC	282
	2	2.4	6	C481G2SC	304
	2.5	3.0	6	C481G2.5SC	304
	3.5	4.2	6	C481G3.5SC	336
	4	4.8	6	C481G4SC	340
	5	6.0	6	C481G5SC	358
	6	7.2	6	C481G6SC	368
	7.5	9.0	6	C481G7.5SC	378
	8	9.6	6	C481G8SC	390
	9	10.8	6	C481G9SC	400
	10	12.0	6	C481G10SC	410
	14	16.8	6	C481G14SC	432
	15	18.0	6	C481G15SC	454

Approximate dimensions Individual capacitors

← 00.00 → Inches

Individual units

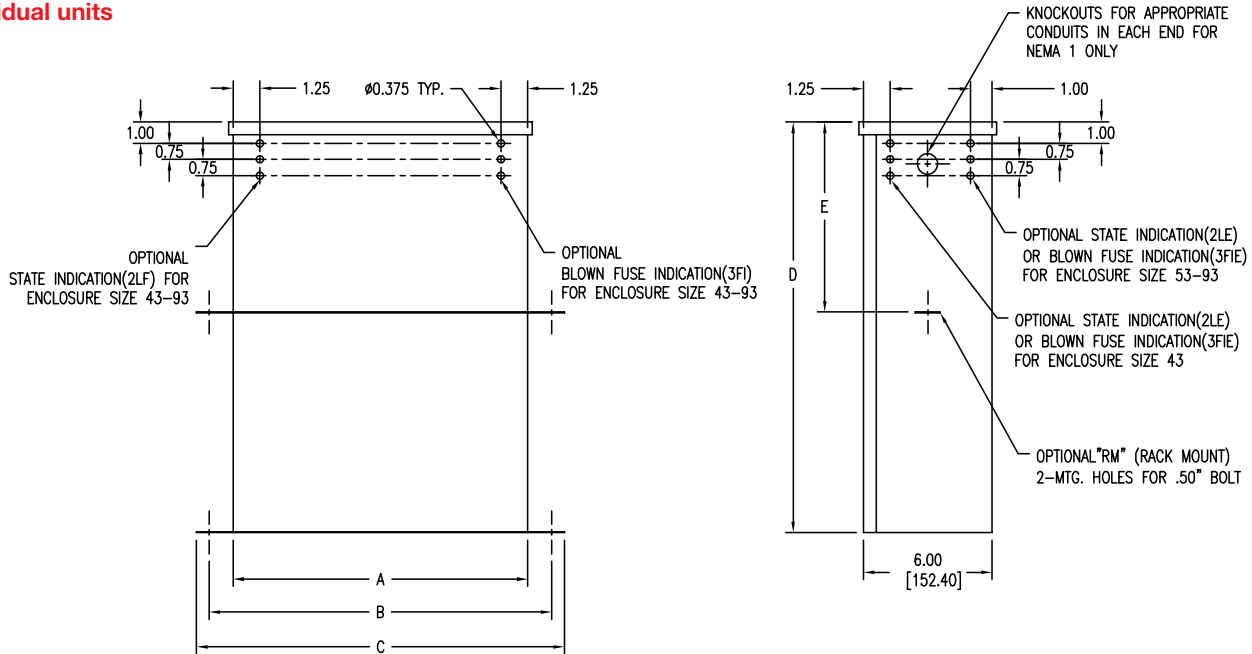

INDIVIDUAL CAPACITOR UNITS						
ENCLOSURE SIZE	A	B	C	D	CONDUIT KNOCKOUT SIZES	RM
						E
43	7.06 179.0	9.31 236.5	10.50 267.0	10.93 278.0	.50 - .75 12.7 - 19.0	N/A
53	13.75 349.0	16.00 406.0	17.18 436.0	12.31 312.0	.75 - 1.0 19.05 - 25.4	5.00 127.0
63	13.75 349.0	16.00 406.0	17.18 436.0	19.18 487.0	1.0 - 1.25 25.4 - 31.75	8.87 225.0
83	13.75 349.0	16.00 406.0	17.18 436.0	26.56 675.0	1.25 - 1.50 31.75 - 38.0	8.87 225.0
93	13.75 349.0	16.00 406.0	17.18 436.0	30.56 776.0	-	8.87 225.0

WALL MOUNTING BRACKET KIT (WM83K)
FOR ENCLOSURE SIZES 43, 53, 63, 83, 93

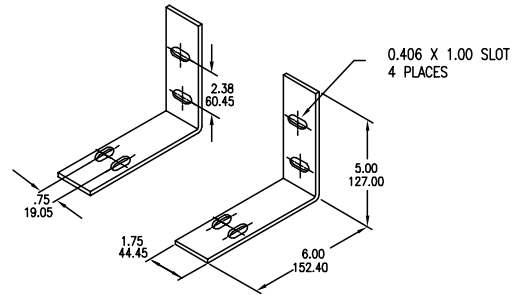

Pump jack capacitor – Steel, enclosure size 43

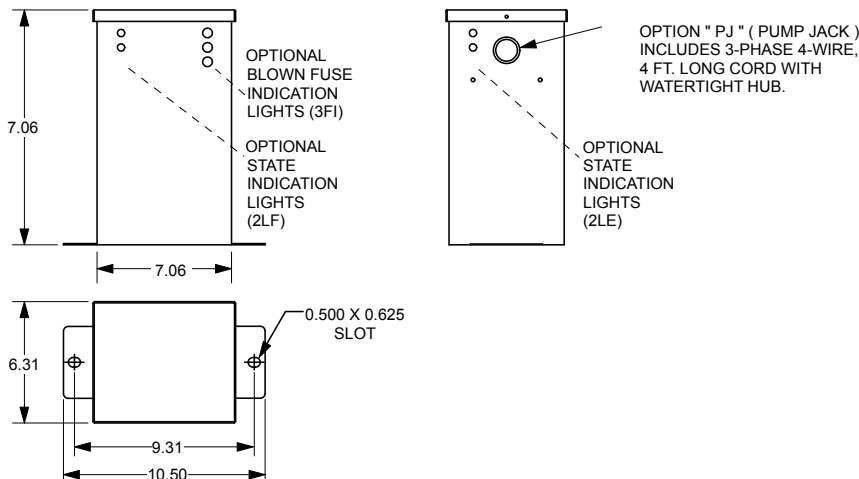

Approximate dimensions Individual capacitors

← 00.00 → Inches

Pole mounting bracket for "PJ" (pump jack) capacitors

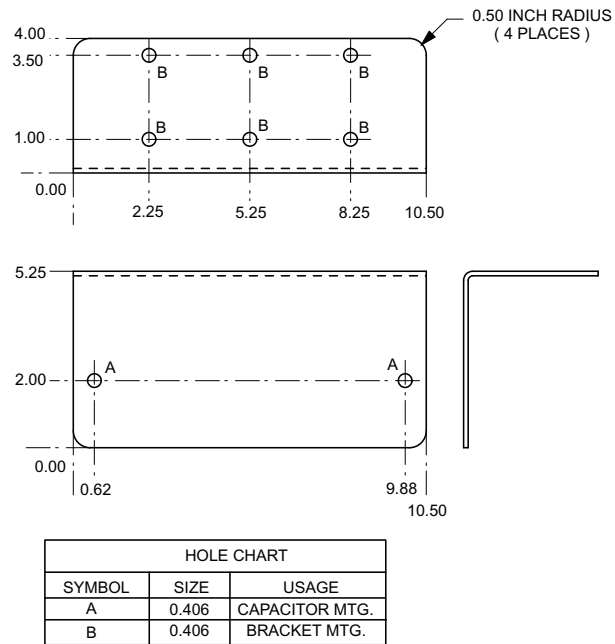

CLMD-13

CLMD-13 Drill plan

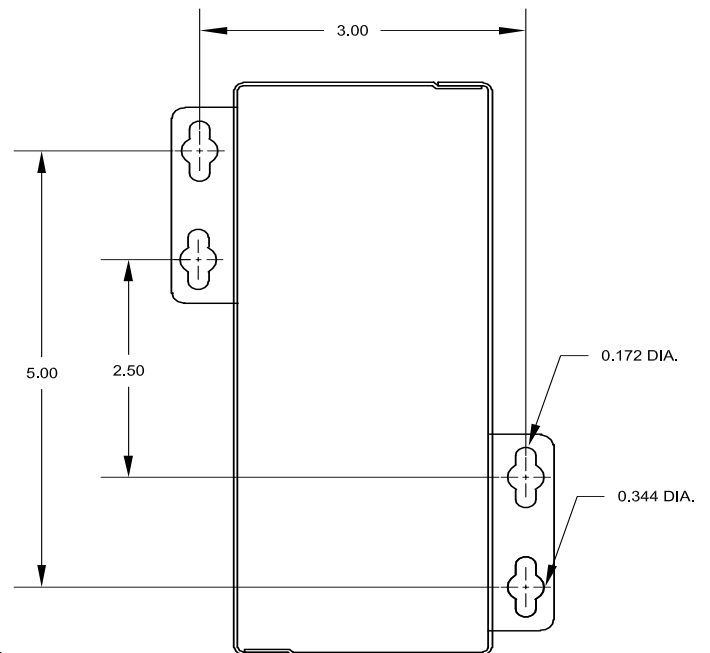
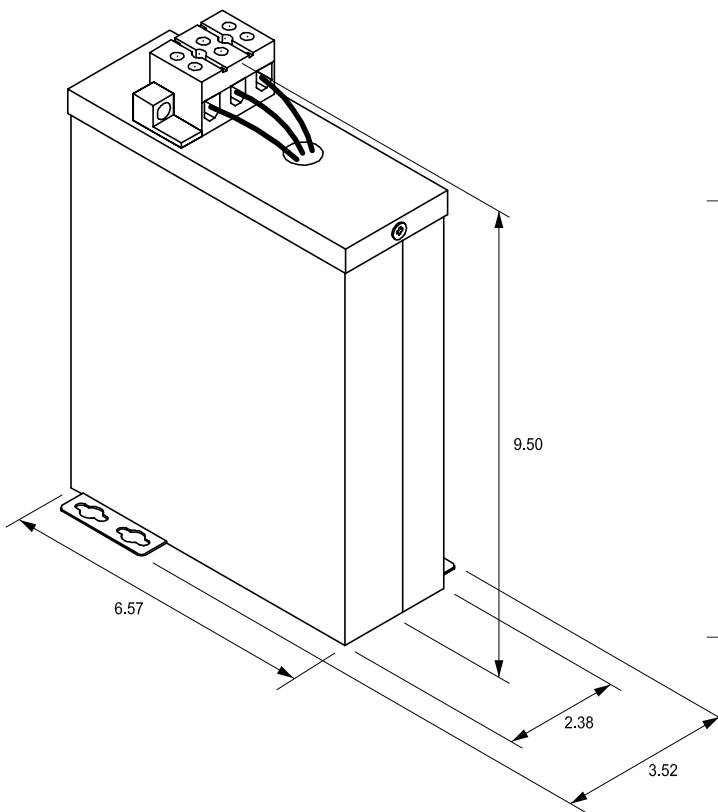

Approximate dimensions Individual capacitors

← 00.00 → Inches

CLMD-13SC — stud connected

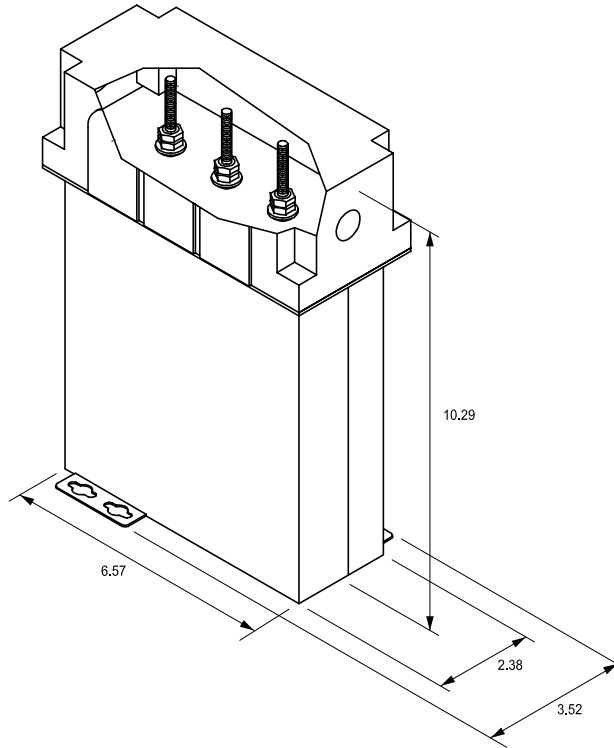

CLMD-13SC — expanded view

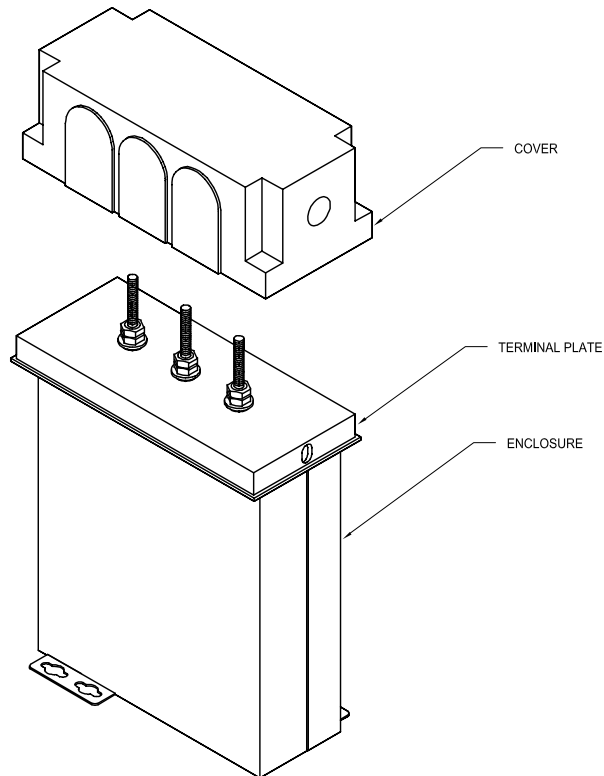

Fixed capacitor banks

3 phase, Internally protected elements

240 & 480 Volt, 60 Hz



Suitable for direct compensation where fixed power factor correction is desired.

Features include:

- Dry environmentally safe construction
- Self healing capability
- Patented Internal Protected Elements
- Individual capacitors connected by bus bar
- Indoor, dusttight or raintight enclosure
- NEMA 1, 3R, 12
- Easy mounting
- Easy electrical connection to large terminals
- Convenient grounding lug

240 Volt, 60 Hz – 3 phase

Enclosure size	kvar rating ①	Qty / kvar	Approx. shipping weight (lbs.)	Enclosure type					
				Indoor – NEMA 1		Outdoor – NEMA 3R		Indoor – NEMA 12	
				Catalog number	List price	Catalog number	List price	Catalog number	List price
63	70	2/35	155	F246G70	Consult factory	F246R70	Consult factory	F246D70	Consult factory
	80	1/35, 1/40	155	F246G80		F246R80		F246D80	
	90	2/45	155	F246G90		F246R90		F246D90	
	100	2/50	155	F246G100		F246R100		F246D100	
	110	2/55	155	F246G110		F246R110		F246D110	
	120	2/60	155	F246G120		F246R120		F246D120	
	130	1/40, 2/45	235	F246G130		F246R130		F246D130	
	150	3/50	235	F246G150		F246R150		F246D150	
	160	1/50, 3/55	155	F246G160		F246R160		F246D160	
	180	3/60	235	F246G180		F246R180		F246D180	
	200	4/50	310	F246G200		F246R200		F246D200	
	250	5/50	370	F246G250		F246R250		F246D250	
	300	5/60	370	F246G300		F246R300		F246D300	

480 Volt, 60 Hz – 3 phase

Enclosure size	kvar rating ①	Qty / kvar	Approx. shipping weight (lbs.)	Enclosure type					
				Indoor – NEMA 1		Outdoor – NEMA 3R		Indoor – NEMA 12	
				Catalog number	List price	Catalog number	List price	Catalog number	List price
63	125	1/55, 1/70	125	F486G125	Consult factory	F486R125	Consult factory	F486D125	Consult factory
	130	2/65	125	F486G130		F486R130		F486D130	
	140	2/70	125	F486G140		F486R140		F486D140	
	150	2/75	125	F486G150		F486R150		F486D150	
83	160	2/80	155	F488G160	Consult factory	F488R160	Consult factory	F488D160	Consult factory
	175	2/87.5	155	F488G175		F488R175		F488D175	
	180	2/90	155	F488G180		F488R180		F488D180	
	200	2/100	155	F488G200		F488R200		F488D200	
63	220	1/70, 2/75	200	F486G220	Consult factory	F486R220	Consult factory	F486D220	Consult factory
	225	3/75	200	F486G225		F486R225		F486D225	
83	240	3/80	235	F488G240	Consult factory	F488R240	Consult factory	F488D240	Consult factory
	250	1/90, 2/80	235	F488G250		F488R250		F488D250	
	260	2/90, 1/80	235	F488G260		F488R260		F488D260	
	280	1/00, 2/90	235	F488G280		F488R280		F488D280	
	300	3/100	235	F488G300		F488R300		F488D300	
	350	4/87.5	310	F488G350		F488R350		F488D350	
	360	4/90	310	F488G360		F488R360		F488D360	
	400	4/100	310	F488G400		F488R400		F488D400	
	450	5/90	370	F488G450		F488R450		F488D450	
	475	5/95	370	F488G475		F488R475		F488D475	
	500	5/100	370	F488G500		F488R500		F488D500	
600	6/100	450	F488G600	F488R600	F488D600				

208 Volt availability

For 208 volt applications, derate the 240V capacitors. The kvar at 208V will be .75 times the kvar at 240V.

NOTE: ABB's patented IPE design eliminates the need for additional overcurrent protection when capacitors are electrically connected on the load side of a motor starter circuit breaker or fusible disconnect switch.

① For additional kvar ratings not listed above, please consult factory.

Fixed capacitor banks

3 Phase, Internally Protected Elements

600 Volt, 60Hz

600 volt, 60Hz – 3 phase

Enclosure size	kvar rating ①	Qty / kvar	Approx. shipping weight (lbs.)	Enclosure type					
				Indoor – NEMA 1		Outdoor – NEMA 3R		Indoor – NEMA 12	
				Catalog number	List price	Catalog number	List price	Catalog number	List price
63	160	2/80	155	F606G160	Consult factory	F606R160	Consult factory	F606D160	Consult factory
83	200	2/100	155	F608G200		F608R200		F608D200	
63	240	3/80	195	F606G240		F606R240		F606D240	
83	270	3/90	230	F608G270		F608R270		F608D270	
	300	3/100	230	F608G300		F608R300		F608D300	
63	320	4/80	250	F606G320		F606R320		F606D320	
83	350	4/87.5	275	F608G350		F608R350		F608D350	
	360	4/90	275	F608G360		F608R360		F608D360	
	400	4/100	275	F608G400		F608R400		F608D400	
	500	5/100	375	F608G500		F608R500		F608D500	
	600	6/100	450	F608G600	F608R600	F608D600			

Capacitor state indication system

240V kvar	480V & 600V kvar	Catalog number suffix	List price adder
90 – 120	125 – 200	-2LE	Consult factory
130 – 180	210 – 300		
200	320 – 400		
250 – 300	450 – 500		
–	600		

The capacitor state indication system consists of two yellow LED lights which illuminate only when the capacitor is energized and functioning at 65% or more of its rated kvar capacity.

The two light system will indicate a failure in any one of the three phases of the capacitor.

Wall mounting assemblies

Type	Catalog number	List price adder
Wall mounting kit, 2 – 6 units per bank	FBWM	Consult factory

NOTE: ABB's patented IPE design eliminates the need for additional overcurrent protection when capacitors are electrically connected on the load side of a motor starter circuit breaker or fusible disconnect switch.

① For additional kvar ratings not listed above, please consult factory.

Fixed capacitor banks

3 Phase, 240 & 480 Volt, 60 Hz

with three fuses and blown fuse indicators



F26G250-3FI

ABB low voltage capacitors are fully protected by the three levels of protection offered by the patented Sequential Protection System which includes dry self-healing capacitors, internally protected elements and the dry non-flammable vermiculite filler. However, some users have traditionally requested external fuses and blown fuse indicators, so these modified units are offered for those applications.

Features include:

- Dry, environmentally safe construction
- Self healing capability
- Patented **Internal Protected Elements**
- Individual capacitors connected by bus bar
- NEMA 1, 3R, 12
- Easy mounting
- Easy electrical connection to large terminals
- Convenient grounding lug
- Each individual capacitor includes three fuses and three blown fuse indication lamps

240 Volt, 60 Hz – 3 phase

Enclosure size	kvar rating [Ⓞ]	Qty / kvar	Approx. shipping weight (lbs.)	Enclosure type					
				Indoor – NEMA 1		Outdoor – NEMA 3R		Indoor – NEMA 12	
				Catalog number	List price	Catalog number	List price	Catalog number	List price
63	70	2/35	135	F246G70-3FI	Consult factory	F246R70-3FI	Consult factory	F246D70-3FI	Consult factory
	80	2/40	135	F246G80-3FI		F246R80-3FI		F246D80-3FI	
	90	2/45	135	F246G90-3FI		F246R90-3FI		F246D90-3FI	
	100	2/50	135	F246G100-3FI		F246R100-3FI		F246D100-3FI	
	110	2/55	135	F246G110-3FI		F246R110-3FI		F246D110-3FI	
	120	2/60	135	F246G120-3FI		F246R120-3FI		F246D120-3FI	
	130	1/40, 2/45	235	F246G130-3FI		F246R130-3FI		F246D130-3FI	
	150	3/50	235	F246G150-3FI		F246R150-3FI		F246D150-3FI	
	160	1/50, 3/55	155	F246G160-3FI		F246R160-3FI		F246D160-3FI	
	180	3/60	235	F246G180-3FI		F246R180-3FI		F246D180-3FI	
	200	4/50	310	F246G200-3FI		F246R200-3FI		F246D200-3FI	
	250	5/50	370	F246G250-3FI		F246R250-3FI		F246D250-3FI	
300	5/60	370	F246G300-3FI	F246R300-3FI	F246D300-3FI				

480 Volt, 60 Hz – 3 phase

Enclosure size	kvar rating [Ⓞ]	Qty / kvar	Approx. shipping weight (lbs.)	Enclosure type					
				Indoor – NEMA 1		Outdoor – NEMA 3R		Indoor – NEMA 12	
				Catalog number	List price	Catalog number	List price	Catalog number	List price
63	125	1/55, 1/70	135	F486G125-3FI	Consult factory	F486R125-3FI	Consult factory	F486D125-3FI	Consult factory
	130	2/65	135	F486G130-3FI		F486R130-3FI		F486D130-3FI	
	140	2/70	135	F486G140-3FI		F486R140-3FI		F486D140-3FI	
	150	2/75	135	F486G150-3FI		F486R150-3FI		F486D150-3FI	
83	160	2/80	155	F488G160-3FI	Consult factory	F488R160-3FI	Consult factory	F488D160-3FI	Consult factory
	175	2/87.5	155	F488G175-3FI		F488R175-3FI		F488D175-3FI	
	180	2/90	155	F488G180-3FI		F488R180-3FI		F488D180-3FI	
	200	2/100	155	F488G200-3FI		F488R200-3FI		F488D200-3FI	
63	220	1/70, 2/75	200	F486G220-3FI	Consult factory	F486R220-3FI	Consult factory	F486D220-3FI	Consult factory
	225	3/75	200	F486G225-3FI		F486R225-3FI		F486D225-3FI	
83	240	3/80	235	F488G240-3FI	Consult factory	F488R240-3FI	Consult factory	F488D240-3FI	Consult factory
	250	1/90, 2/80	235	F488G250-3FI		F488R250-3FI		F488D250-3FI	
	260	2/90, 1/80	235	F488G260-3FI		F488R260-3FI		F488D260-3FI	
	280	1/100, 2/90	235	F488G280-3FI		F488R280-3FI		F488D280-3FI	
	300	3/100	235	F488G300-3FI		F488R300-3FI		F488D300-3FI	
	350	4/87.5	310	F488G350-3FI		F488R350-3FI		F488D350-3FI	
	360	4/90	310	F488G360-3FI		F488R360-3FI		F488D360-3FI	
	400	4/100	310	F488G400-3FI		F488R400-3FI		F488D400-3FI	
	450	5/90	370	F488G450-3FI		F488R450-3FI		F488D450-3FI	
	475	5/95	370	F488G475-3FI		F488R475-3FI		F488D475-3FI	
	500	5/100	370	F488G500-3FI		F488R500-3FI		F488D500-3FI	
	600	6/100	450	F488G600-3FI		F488R600-3FI		F488D600-3FI	

208 Volt availability

For 208 volt applications, derate the 240V capacitors. The kvar at 208V will be .75 times the kvar at 240V.

NOTE: ABB's patented IPE design eliminates the need for additional overcurrent protection when capacitors are electrically connected on the load side of a motor starter circuit breaker or fusible disconnect switch.

Ⓞ For additional kvar ratings not listed above, please consult factory.

Fixed capacitor banks

3 phase, 600 Volt, 60 Hz

with three fuses and blown fuse indicators

600 volt, 60Hz – 3 phase

Enclosure size	kvar rating ^①	Qty / kvar	Approx. shipping weight (lbs.)	Enclosure type					
				Indoor – NEMA 1		Outdoor – NEMA 3R		Indoor – NEMA 12	
				Catalog number	List price	Catalog number	List price	Catalog number	List price
63	160	2/80	155	F606G160-3FI	Consult factory	F606R160-3FI	Consult factory	F606D160-3FI	Consult factory
83	200	2/100	155	F608G200-3FI		F608R200-3FI		F608D200-3FI	
63	240	3/80	195	F606G240-3FI		F606R240-3FI		F606D240-3FI	
83	270	3/90	230	F608G270-3FI		F608R270-3FI		F608D270-3FI	
	300	3/100	230	F608G300-3FI		F608R300-3FI		F608D300-3FI	
63	320	4/80	250	F606G320-3FI		F606R320-3FI		F606D320-3FI	
83	350	4/87.5	275	F608G350-3FI		F608R350-3FI		F608D350-3FI	
	360	4/90	275	F608G360-3FI		F608R360-3FI		F608D360-3FI	
	400	4/100	275	F608G400-3FI		F608R400-3FI		F608D400-3FI	
	500	5/100	375	F608G500-3FI		F608R500-3FI		F608D500-3FI	
	600	6/100	450	F608G600-3FI	F608R600-3FI	F608D600-3FI			

Capacitor state indication system

240V kvar	480V & 600V kvar	Catalog number suffix	List price adder
90 – 120	125 – 200	-2LE	Consult factory
130 – 180	210 – 300		
200	320 – 400		
250 – 300	450 – 500		
–	600		

The capacitor state indication system consists of two yellow LED lights which illuminate only when the capacitor is energized and functioning at 65% or more of its rated kvar capacity.

The two light system will indicate a failure in any one of the three phases of the capacitor.

Wall mounting assemblies ^②

Type	Catalog number	List price adder
Wall mounting kit, 2 – 6 units per bank	FBWM	Consult factory

NOTE: ABB's patented IPE design eliminates the need for additional overcurrent protection when capacitors are electrically connected on the load side of a motor starter circuit breaker or fusible disconnect switch.

^① For additional kvar ratings not listed above, please consult factory.

Approximate dimensions Fixed capacitor bank, floor mounted

Low Voltage
Network Quality

← 00.00 → Inches

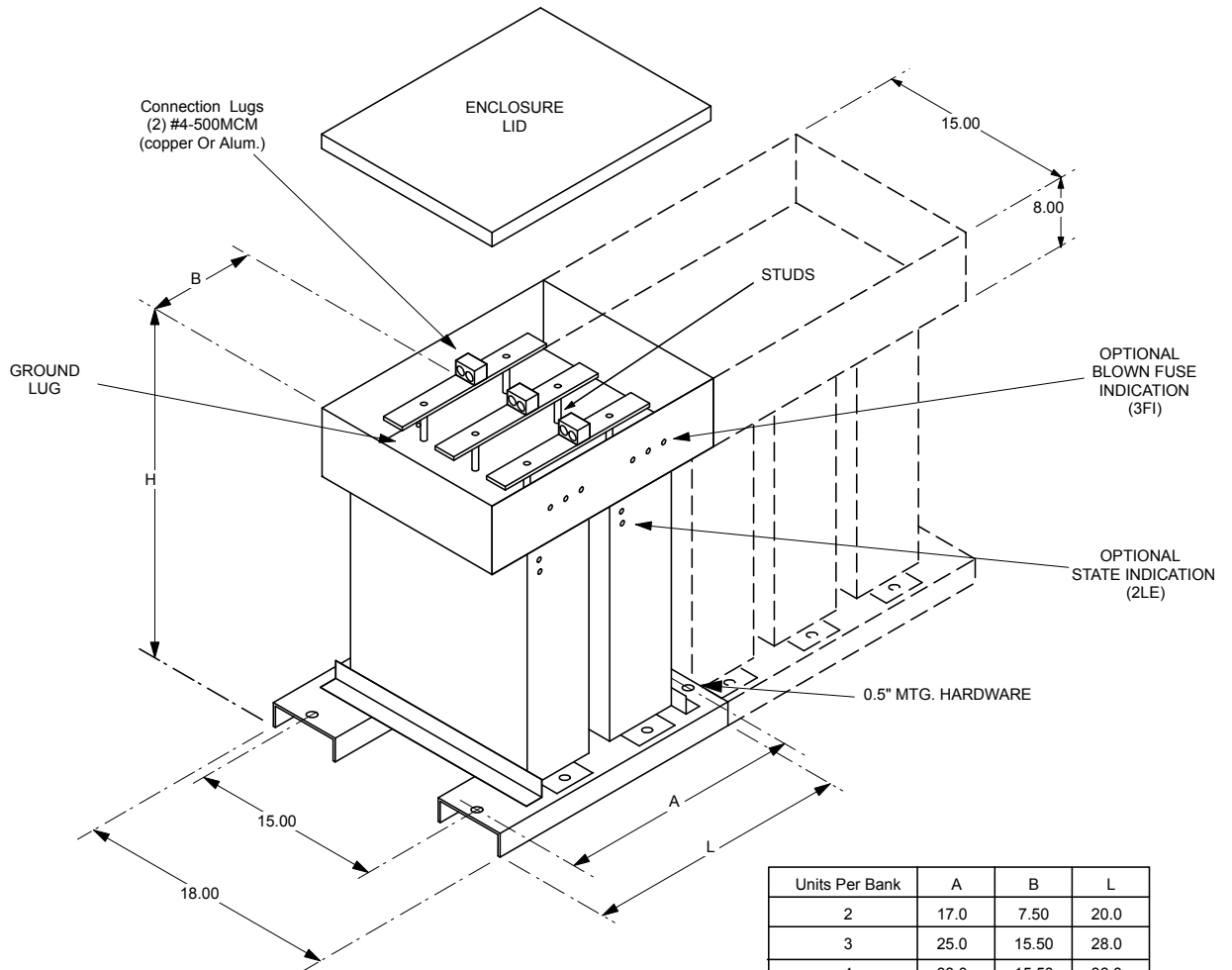

Units Per Bank	A	B	L
2	17.0	7.50	20.0
3	25.0	15.50	28.0
4	33.0	15.50	36.0
5	41.0	15.50	44.0
6	49.0	22.50	52.0

Unit Size	H
CLMD-53	22.50
CLMD-63	29.50
CLMD-83	36.50

Approximate dimensions Fixed bank, wall mounted

← 00.00 → Inches

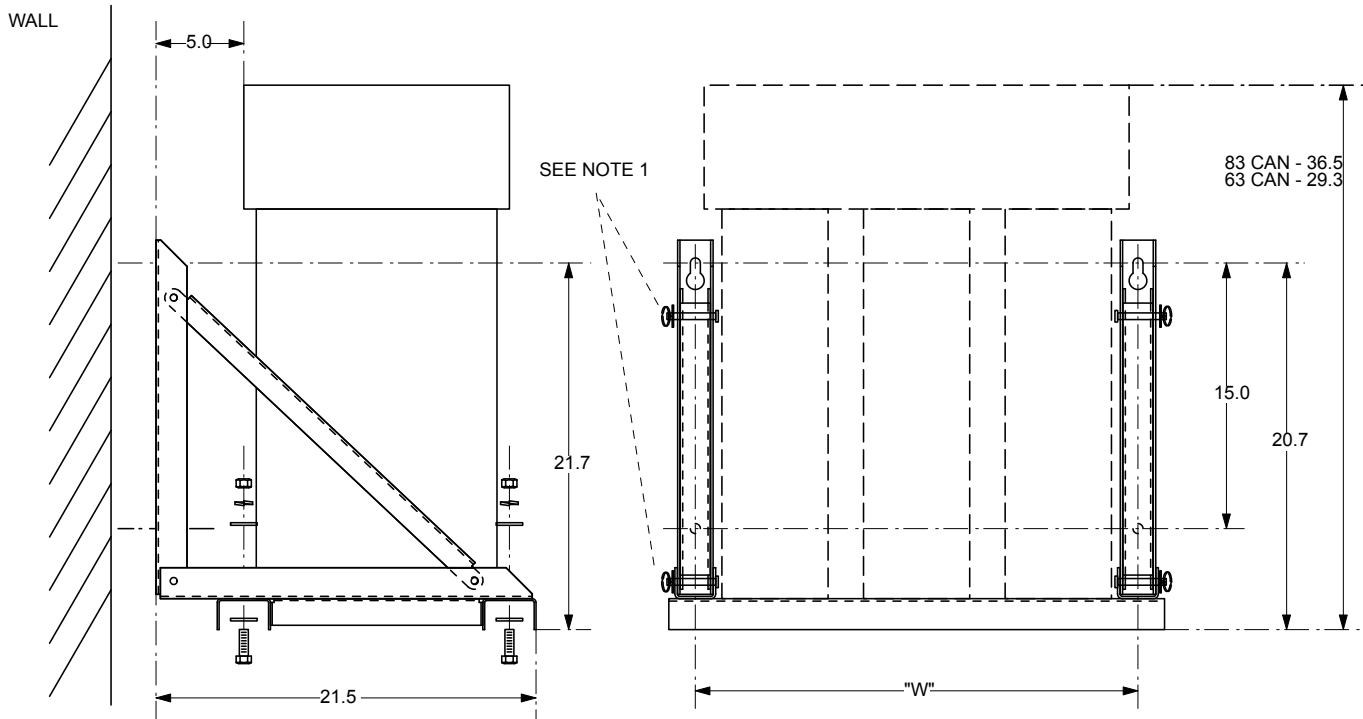

NOTE 1: POSITION SPLIT RINGS TOWARD OUTSIDE OF BANK

NO. OF CAPS	MTG WIDTH "W"
2	17.0
3	25.0
4	33.0
5	41.0
6	49.0

MOUNT CAPACITOR ASSEMBLY TO WALL USING FOUR (4) 1/2" BOLTS. "KEY HOLE" MOUNTING HOLES ARE PROVIDED AT TOP OF MOUNTING BRACKETS.

WALL MOUNTING BRACKETS ARE ATTACHED TO FIXED BANK USING FOUR (4) 1/2-13 X 1.25" BOLTS AS SHOWN. TORQUE HARDWARE TO 50 LBS-FT.

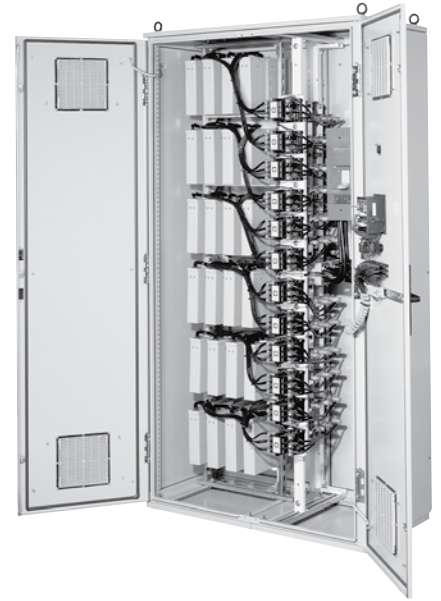

300 & 1200 AutoBank

ABB 300 & 1200 Automatic banks

ABB provides the complete solution to automatic power factor correction by packaging proven ABB components. ABB capacitors, contactors, power factor controllers, circuit breakers, fusible disconnects, and ABB pushbuttons together provide a system of the highest quality. ABB capacitors provide exceptional performance using an environmentally safe dry type design. ABB provides a complete range of contactors designed for capacitor switching. ABB's power factor controller offers an easy-to-use microprocessor-based controller with built-in power factor meter. A variety of disconnect options are available, including ABB circuit breakers, fusible and non-fusible switches.

• Modularity

The modular design allows for the installation of additional power and switch modules as well as various options. Additional units may be connected in parallel. The number of capacitors and contactors included in the power modules depends on the automatic capacitor bank total power and the possible requirement for anti-resonance reactors.

• Options

Anti-resonance reactors, filters, blown fuse indication, push to test blown fuse indication, non-fused and fused disconnect switches and circuit breakers are optional equipment items that can be factory installed in the automatic capacitor bank.

• Approvals

ABB AutoBanks can be UL Panel Listed (UL File # E105450) per application.

• High reliability

The ABB AutoBank incorporates the well-proven features of ABB dry type power factor correction capacitor technology. The use of an ABB power factor controller and endurance-tested ABB contactors ensure the highest reliability of the equipment.

• Very low losses

Capacitor total losses are less than 0.5 watts per kvar. AutoBank total losses (without reactors), including accessories such as power factor controller and contactors are less than 1.5 watts per kvar.

• Complete environmental acceptability

ABB capacitors have a dry type dielectric with no free liquid and do not pose any risk of leakage or pollution of the environment.

• Unique sequential protection system

3 phase ABB capacitors are included with AutoBank products. These ABB capacitors utilize a patented Sequential protection System which ensures that each individual capacitor element is selectively and reliably disconnected from the circuit at the end of its life.

• Long life

Low losses and the self-healing properties of ABB capacitor elements help to ensure long operating life.

General information

Description & technical data

Catalog number explanation

• Safety

ABB capacitors are manufactured with vermiculite, a nonflammable and nontoxic material. The dry vermiculite safely absorbs any energy produced within the capacitor enclosure and prevents any fire hazard in case of failure. Unique cooling fins are fitted to surround each capacitor element providing effective heat dissipation.

• ABB power factor controller

ABB microprocessor-based and programmable Power Factor Controllers (PFCs) provide for the setting of the target power factor and the sensitivity of the system regulation. The PFCs maintain the selected power factor by switching on or off one or more capacitor steps depending on the load conditions of the system.

• Compact design ensures quick installation

The AutoBank has compact overall dimensions, top or bottom cable entry access, and lifting eyes aid in fast, efficient handling and installation.

Harmonic effect on capacitors

Combinations of capacitors and system reactances form series and parallel tuned circuits at certain frequencies. When harmonic sources are added to the system, this can result in higher than rated currents or higher than rated voltages on the system components.

AutoBanks can be designed to operate in harmonic environments. Tuning reactors are added to keep the capacitor currents within rated values and keep system voltages to desired levels. Tuning frequencies of the AutoBank can be designed to suit your system requirements. Please consult factory.

Contents

Standard ABB AutoBank products include:

- 1 to 12 capacitor steps, three phase
- Incoming line termination (unless other disconnecting means is specified)
- Capacitor stage indicator lights
- Power on light
- One ABB power factor controller equipped with:
 - Programmable thresholds which allow protection of the capacitor bank from over and undervoltage, overtemperature and excessive harmonic distortion
 - Full graphics LCD display
 - Manual/automatic control
 - Indication of capacitive or inductive load and the number of steps energized
 - Measures and monitors kW, kVA, kVAR, Vrms, Arms, Temperature, THDV(%), THDI(%), Hz, power factor, voltage harmonics V2-V49(%), current harmonics I2-I49(%), alarm
 - Customizable switching sequence, linear or circular - normal or integral - direct or progressive switching strategies available
 - Automatic adaptation to network phase rotation and C.T. terminals
- ABB contactors
- Discharge resistors
- Power fuses
- Control fuses
- Multi-tap CT range 500/5 – 4000/5 in 500/5 increments. Window size 4" x 7"

Technical data

Rated voltage: 240 – 600V, 50/60 Hz, 3 phase

Standard kvar steps: 25, 50 & 100 kvar (other kvar step sizes available)

Control voltage: 120V, 60 Hz

Power factor setting: Between 0.70 capacitive and 0.7 inductive

C/k setting: Between 0.05 and 1A

Operation: Automatic or manual with step indication. LED indication of the number of capacitors energized and the capacitive or inductive demand.

Discharge resistors included

Dielectric losses: Less than 0.2 watt/kvar

Capacitor total losses: Less than 0.5 watt/kvar

Automatic bank total losses (without reactors) including accessories such as contactors and PF controller: Less than 1.5 watt/kvar

ABB dry type self-healing capacitors

Capacitor dielectric test:

- Between terminals and container: 3.0 kV, 60 seconds.

Capacitor automatic bank test:

- Functional test
- Dielectric test

Enclosures:

- NEMA 1, 3R and Dustproof (RAL 7032, Beige)

Top or bottom cable entry

Dimensions: Per application

Ambient temperature: -40°C to +40°C

Installation: Lifting eyes are provided. Installation instructions are supplied with each unit.

NOTICE

Placement and orientation of the current transformer are very important for the correct operation of the automatic capacitor bank.

A 4 G 600 C 6 A 2 P

Catalog number explanation

F = blown fuse indication, P = BFI with push to test

Harmonic tuning (Consult factory)

Switching sequence: A 1:1:1:1, B 1:2:2:2, C 1:2:4:4, D-1:1:2:2

Number of capacitors

Disconnecting means – B = terminal, C = circuit breaker,

D = non-fused disconnect switch, F = fused disconnect switch

kvar rating

Enclosure type – G = indoor, R = outdoor, D = dust proof

Voltage – 2 = 240, 4 = 480, 6 = 600

Model – A = 1200, AA = 300

AutoBank 300

240, 480 & 600 Volt, 60 Hz

**Low Voltage
Network Quality**

Description

Automatic power factor correction system in a compact design.

- Ratings: 240V: 25 – 150 kvar
480V: 50 – 300 kvar
600V: 100 – 300 kvar
- Size: 66"H x 32"W x 20"D
- Fusing: Each step and each phase
- Proven ABB Components:
ABB dry-type capacitors
ABB micro-processor based controller
ABB contactors rated for capacitive switches
- CT Split core multi-tap CT provided with each AutoBank
- Options: ABB main circuit breaker
Blown fuse indication
Push-to-test blown fuse indication
Outdoor enclosure
Dustproof enclosure



240 Volt

kvar	Approximate weight (lbs)	Indoor		Outdoor		Dustproof	
		Catalog number	List price	Catalog number	List price	Catalog number	List price
25	600	AA2G25B5A	Consult factory	AA2R25B5A	Consult factory	AA2D25B5A	Consult factory
50	600	AA2G50B5A		AA2R50B5A		AA2D50B5A	
75	600	AA2G75B6A		AA2R75B6A		AA2D75B6A	
100	600	AA2G100B8A		AA2R100B8A		AA2D100B8A	
125	600	AA2G125B10A		AA2R125B10A		AA2D125B10A	
150	600	AA2G150B12A		AA2R150B12A		AA2D150B12A	

480 Volt

kvar	Approximate weight (lbs)	Indoor		Outdoor		Dustproof	
		Catalog number	List price	Catalog number	List price	Catalog number	List price
50	600	AA4G50B3B	Consult factory	AA4R50B3B	Consult factory	AA4D50B3B	Consult factory
75	600	AA4G75B5A		AA4R75B5A		AA4D75B5A	
100	600	AA4G100B5A		AA4R100B5A		AA4D100B5A	
125	600	AA4G125B5A		AA4R125B5A		AA4D125B5A	
150	600	AA4G150B6A		AA4R150B6A		AA4D150B6A	
175	600	AA4G175B7A		AA4R175B7A		AA4D175B7A	
200	600	AA4G200B8A		AA4R200B8A		AA4D200B8A	
225	600	AA4G225B9A		AA4R225B9A		AA4D225B9A	
250	600	AA4G250B10A		AA4R250B10A		AA4D250B10A	
300	600	AA4G300B12A		AA4R300B12A		AA4D300B12A	

600 Volt

kvar	Approximate weight (lbs)	Indoor		Outdoor		Dustproof	
		Catalog number	List price	Catalog number	List price	Catalog number	List price
100	600	AA6G100B5A	Consult factory	AA6R100B5A	Consult factory	AA6D100B5A	Consult factory
125	600	AA6G125B5A		AA6R125B5A		AA6D125B5A	
150	600	AA6G150B6A		AA6R150B6A		AA6D150B6A	
175	600	AA6G175B7A		AA6R175B7A		AA6D175B7A	
200	600	AA6G200B8A		AA6R200B8A		AA6D200B8A	
225	600	AA6G225B9A		AA6R225B9A		AA6D225B9A	
250	600	AA6G250B10A		AA6R250B10A		AA6D250B10A	
300	600	AA6G300B12A		AA6R300B12A		AA6D300B12A	

For other kvar sizes, number of steps, or options, please consult your local ABB Control representative.

NOTE: ABB automatic banks can be designed for harmonic environments. Please consult the factory concerning harmonic issues.

AutoBank 1200

480 & 600 Volt, 60 Hz

Description

Modular design delivers sought after features:

- 480V & 600V units
- Compact size
- Easy installation & start-up
 - Bottom & top cable entry
 - Simple to operate ABB controller
- Copper bus bar
- Fusing of each step and in each phase
- Proven ABB components
 - ABB dry type capacitors
 - ABB micro-processor based controller
 - ABB contactors rated for capacitor switching
- Options
 - ABB circuit breakers or fusible & non-fusible disconnect switches
 - Blown fuse indication
 - Push to test
 - Outdoor enclosures
 - Dustproof enclosures
- Consult factory for other sizes
- CT: split core, multi-tap current transformers provided with each AutoBank



480 Volt

kvar	Approximate weight (lbs)	Indoor		Outdoor		Dustproof	
		Catalog number	List price	Catalog number	List price	Catalog number	List price
100	1000	A4G100B2A	Consult factory	A4R100B2A	Consult factory	A4D100B2A	Consult factory
125	1000	A4G125B3B		A4R125B3B		A4D125B3B	
150	1000	A4G150B3A		A4R150B3A		A4D150B3A	
175	1000	A4G175B4B		A4R175B4B		A4D175B4B	
200	1000	A4G200B4A		A4R200B4A		A4D200B4A	
225	1000	A4G225B5B		A4R225B5B		A4D225B5B	
250	1000	A4G250B5A		A4R250B5A		A4D250B5A	
300	1000	A4G300B6A		A4R300B6A		A4D300B6A	
350	1000	A4G350B7A		A4R350B7A		A4D350B7A	
400	1200	A4G400B8A		A4R400B8A		A4D400B8A	
450	1200	A4G450B9A		A4R450B9A		A4D450B9A	
500	1200	A4G500B10A		A4R500B10A		A4D500B10A	
550	1200	A4G550B11A		A4R550B11A		A4D550B11A	
600	1200	A4G600B12A		A4R600B12A		A4D600B12A	
650	1900	A4G650B7B		A4R650B7B		A4D650B7B	
700	1900	A4G700B7A		A4R700B7A		A4D700B7A	
800	1900	A4G800B8A	A4R800B8A	A4D800B8A			
900	1900	A4G900B9A	A4R900B9A	A4D900B9A			
1000	2100	A4G1000B10A	A4R1000B10A	A4D1000B10A			
1100	2100	A4G1100B11A	A4R1100B11A	A4D1100B11A			
1200	2100	A4G1200B12A	A4R1200B12A	A4D1200B12A			

600 Volt

kvar	Approximate weight (lbs)	Indoor		Outdoor		Dustproof	
		Catalog number	List price	Catalog number	List price	Catalog number	List price
100	1000	A6G100B2A	Consult factory	A6R100B2A	Consult factory	A6D100B2A	Consult factory
125	1000	A6G125B3B		A6R125B3B		A6D125B3B	
150	1000	A6G150B3A		A6R150B3A		A6D150B3A	
175	1000	A6G175B4B		A6R175B4B		A6D175B4B	
200	1000	A6G200B4A		A6R200B4A		A6D200B4A	
225	1000	A6G225B5B		A6R225B5B		A6D225B5B	
250	1000	A6G250B5A		A6R250B5A		A6D250B5A	
300	1000	A6G300B6A		A6R300B6A		A6D300B6A	
350	1000	A6G350B7A		A6R350B7A		A6D350B7A	
400	1200	A6G400B8A		A6R400B8A		A6D400B8A	
450	1200	A6G450B9A		A6R450B9A		A6D450B9A	
500	1200	A6G500B10A		A6R500B10A		A6D500B10A	
550	1200	A6G550B11A		A6R550B11A		A6D550B11A	
600	1200	A6G600B12A		A6R600B12A		A6D600B12A	
650	1800	A6G650B7B		A6R650B7B		A6D650B7B	
700	1800	A6G700B7A		A6R700B7A		A6D700B7A	
800	1800	A6G800B8A	A6R800B8A	A6D800B8A			
900	1800	A6G900B9A	A6R900B9A	A6D900B9A			
1000	2100	A6G1000B10A	A6R1000B10A	A6D1000B10A			
1100	2100	A6G1100B11A	A6R1100B11A	A6D1100B11A			
1200	2100	A6G1200B12A	A6R1200B12A	A6D1200B12A			

Factory modifications Approximate dimensions AutoBank

← 00.00 → Inches

Current transformers (split core)

This split core current transformer is designed for use with automatic capacitor banks. The primary current will be determined by:

$$I = \frac{\text{kVA} \times 1000}{V \times 1.732}$$

The kVA value should represent the peak quarterhour demand. Split core current transformers are designed for assembly to an existing electrical installation without the need for dismantling the primary bus or cables. The portion of the transformer marked "this end removable" can be disassembled and then reassembled around the conductors that require current monitoring. The current transformer must have its secondary terminals short-circuited or the load connected before energizing the primary circuit.

Multi-tap split core current transformers provided with each AutoBank.

Approximate dimensions

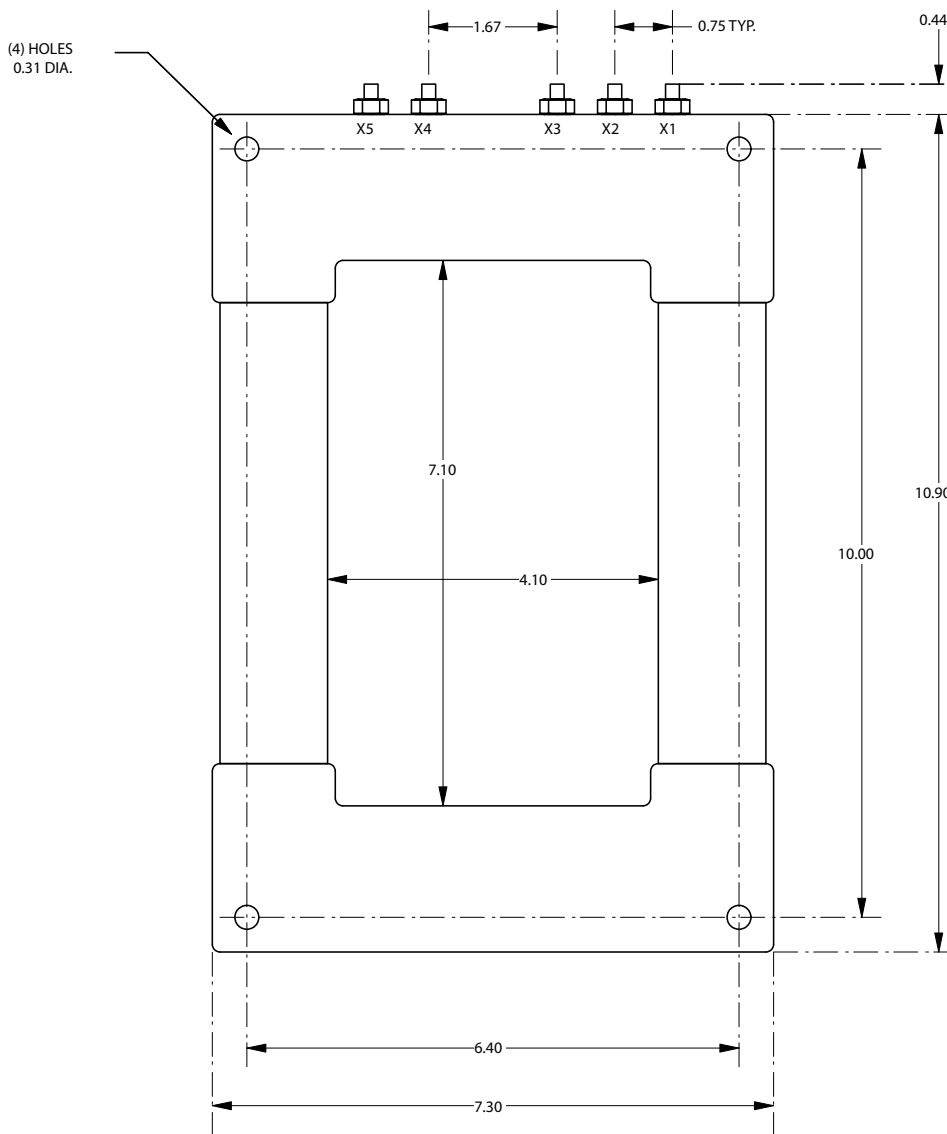

RATIO	TAPS
500:5	X1 - X2
1000:5	X3 - X4
1500:5	X2 - X3
2000:5	X1 - X3
2500:5	X2 - X4
3000:5	X1 - X4
3500:5	X2 - X5
4000:5	X1 - X5

OVERALL DIMENSIONS: HEIGHT = 11.34, WIDTH = 7.30, DEPTH = 1.63

Approximate dimensions AutoBank 300

← 00.00 → Inches

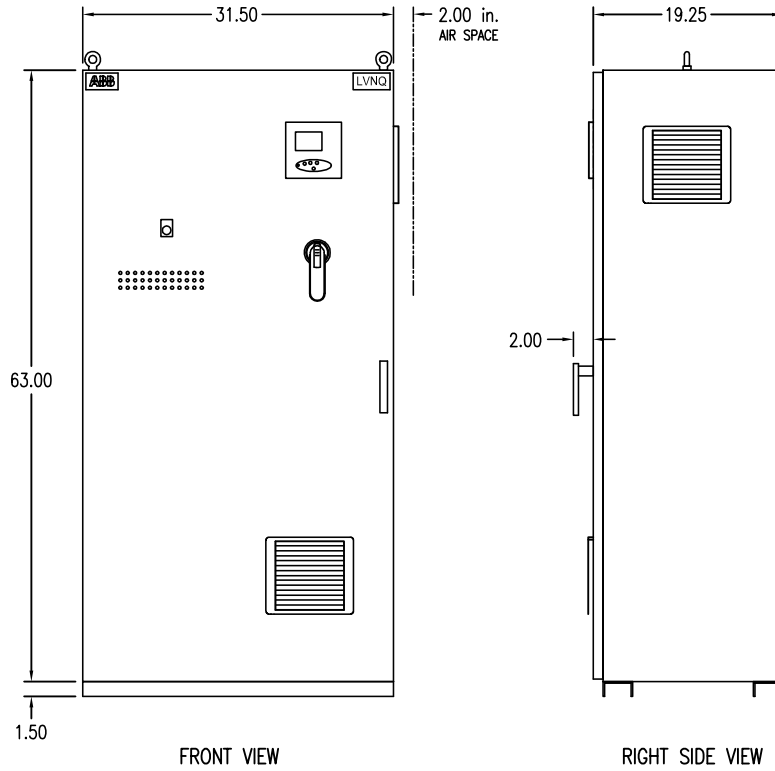

INDOOR BANK, NEMA 1

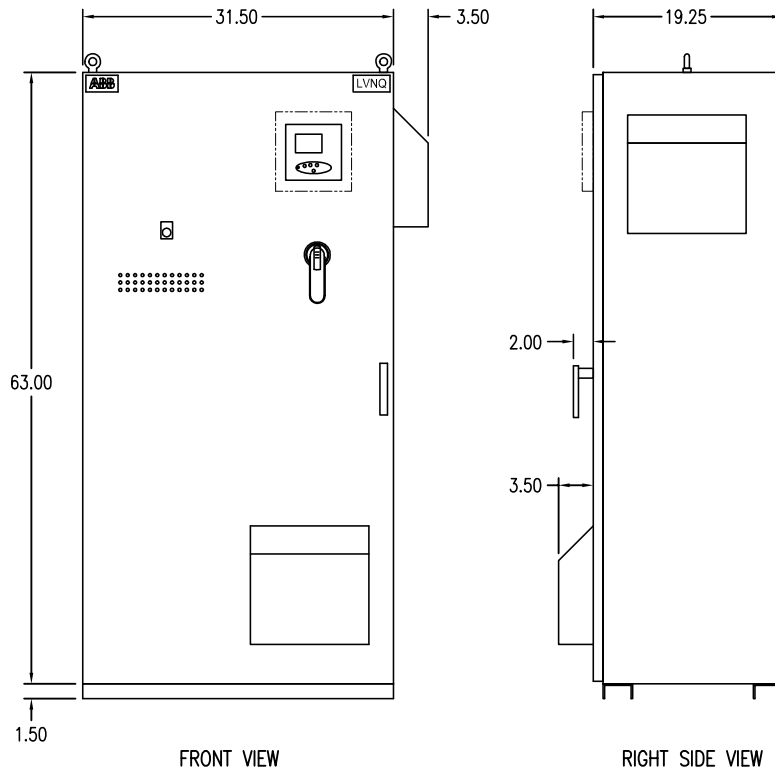

OUTDOOR BANK, NEMA 3R

Approximate dimensions AutoBank 1200

Low Voltage
Network Quality

← 00.00 → Inches

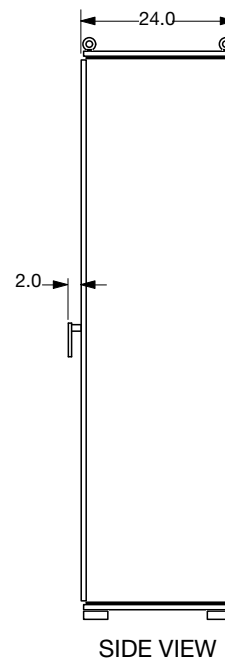
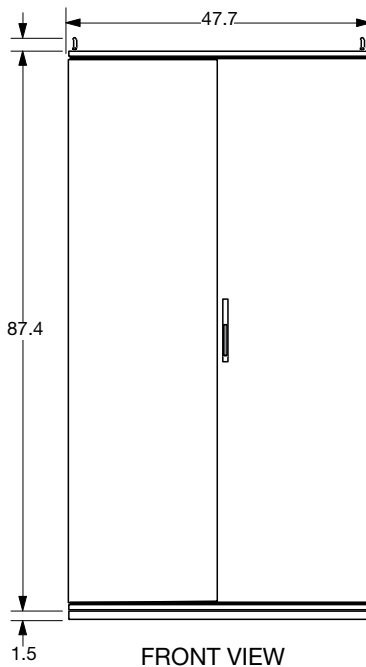
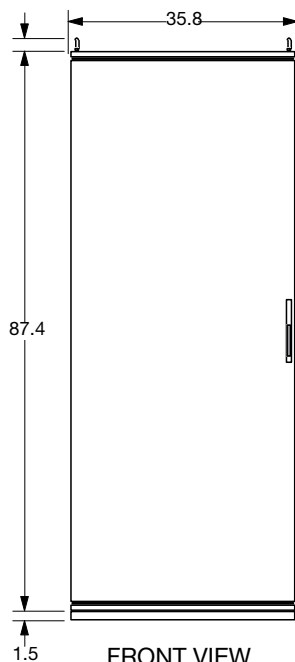

KVAR	OVERALL WIDTH			
	MAIN LUGS	CIRCUIT BREAKER	FUSED SWITCH	NON-FUSED SWITCH
100	36	36	36	36
125	36	36	36	36
150	36	36	36	36
175	36	36	36	36
200	36	36	36	36
225	36	36	36	36
250	36	36	36	36
300	36	36	36	36
350	36	36	48	48
400	36	36	48	48
450	48	48	72	72
500	48	48	—	72
550	48	48	—	72
600	48	48	—	72
650	72	72	—	84
700	72	84	—	84
800	72	84	—	84
900	84	96	—	96
1000	84	96	—	96
1100	84	96	—	120
1200	84	96	—	120

DynaComp



DynaComp

One cycle response, transient-free capacitor switching with no limit to the number of operations

Typical applications

- Any critical loads which cannot be interrupted by transients:
 - Hospitals
 - Airports
 - Computer networking centers
 - High technology manufacturing operations
 - Others
- Loads which require extremely rapid switching (less than one cycle, 16.7 ms) reactive compensation:
 - Welders
 - Elevators
 - DC winches (off-shore oil platforms)
 - Mining drag lines
 - Mining conveyors
 - Rolling mills
 - Cranes (Port Authority)
 - Ski lift drives
 - Stamping
 - Saw mills
 - Light rail transit systems
 - Others

Product description

The ABB Dynamic Response Compensator or DynaComp is a capacitor or filter circuit switched by solid state power electronic devices without any moving parts. It is the ultimate solution to the most demanding applications in rapid power factor compensation, filtering or transient control.

Reactive load switching which causes disturbances on the network or where very rapid compensation or filtering is required are major applications for DynaComp.



DynaComp's solid state switching concept, combined with the well proven features of ABB power capacitor technology, provides the following exceptional advantages:

• Dynamic response time and ultra-rapid switching

DynaComp's solid state switching allows it to achieve dynamic response times in the range of one cycle. A typical application of DynaComp is for lifting devices requiring rapidly varying amounts of reactive power. By installing a DynaComp close to a crane or an elevator, voltage drops can be minimized and disturbances on other equipment avoided. Simultaneously, the reactive power will be efficiently compensated locally, an impossible task with conventional equipment. The principle applies to many other types of equipment with sudden large reactive power requirements such as large motors, welders, large injection molding machines, etc.

General information DynaComp

• Transient free switching

DynaComp does not disturb sensitive networks or sensitive equipment. The switching operation is executed by solid state devices, whose main advantage is to enable transient free switching with no wearing parts.

• Frequent switching capability

The absence of moving parts ensures DynaComp a high reliability without limitation of the number of switching applications. Welding and lifting devices are typical applications of loads requiring large amounts of reactive power with a frequent switching cycle. Switching events in the range of over 100,000 times per day are achievable with DynaComp

• High reliability

DynaComp incorporates the well proven features of ABB dry type power factor capacitor technology. Thyristor switching uses no moving parts. The DynaComp can be UL panel listed per application.

• Versatility & Options

DynaComp's electronic solid state switching is applicable to capacitor banks and detuned or tuned filter banks. An important advantage with filter applications is the improvement in rapidly switching of the filter bank. The DynaComp can be provided with an ABB main breaker or main fused or non-fused disconnect switch.

• Modularity & Expansion

Although DynaComp products must be designed for individual applications, they can be constructed rapidly due to their modular design. Additional units may be connected in parallel, allowing for the same reliable switching functions.

• Safety

ABB capacitors are filled with vermiculite, a nonflammable and nontoxic material. The dry vermiculite safely absorbs any energy produced within the capacitor enclosure and

prevents any fire hazard in case of failure.

Unique cooling fins are fitted to surround each capacitor element and to provide effective heat dissipation.

• Long life

The absence of moving parts and the self-healing properties of ABB capacitor elements ensure the DynaComp's long life.

• Unique Sequential Protection System

The ABB patented Sequential Protection System ensures that each individual capacitor element is selectively and reliably disconnected from the circuit at the end of its life.

• Complete environmental acceptability

ABB capacitors have a dry type dielectric with no free liquid and do not pose any risk of leakage or pollution of the environment.

• ABB VAR controller

ABB microprocessor-based and programmable VAR controller maintains VAR flows to desired levels.

• Compact design ensures quick installation

DynaComp's compact overall dimensions, standard top entry cable access, and lifting eyes aid in fast, efficient handling and installation.

Harmonic Effect on Capacitors

Combinations of capacitors and system reactances form series and parallel tuned circuits at certain frequencies. When harmonic sources are added to the system, this can result in higher than rated currents or higher than rated voltages on the system components.

DynaComp can be designed to operate in harmonic environments. Tuning reactors are added to keep the capacitor currents within rated values and keep system voltages to desired levels. Tuning frequencies of the DynaComp can be designed to suit your system requirements. Please consult factory.

Contents

DynaComp products include:

- Incoming line termination (unless other disconnecting means is specified.)
- One or more capacitor steps, single or three phase
- One ABB RVT-D controller equipped with:
 - Automatic no-voltage release
 - Menu driven interface w/LCD display
 - Icon indicating a capacitive or inductive load add the number of steps energized.
 - Circular or linear switching
- ABB capacitors
- One DynaSwitch per capacitor step
- Discharge resistors
- Power fuses
- Control fuses
- Multi-tap CT range: 500/5 – 4000/5 in 500/5 increments. Window size 4" x 7".

Technical Data

Rated voltage

Up to 240-600V, 50/60Hz, single or 3 phase

Capacitor step rating

Up to 400 kvar at 480V

Operation: Automatic or manual with step indication. LED indication of the number of capacitors energized and the capacitive or inductive demand.

Discharge resistors included.

ABB dry type self-healing capacitors.

Enclosures:

NEMA 1, 3R &
Dustproof

Dimensions:

 Per application

Ambient temp.:

 -40°C to +40°C

Installation: Lifting eyes are provided. Installation instructions are supplied with each unit.

D 4 G 500 C 10 A 2

Catalog numbering explanation

Harmonic tuning (consult factory)

Switching sequence - A 1:1:1:1 B 1:2:2:2 C 1:2:4:4 D 1:2:4:8:8

Number of capacitors

Disconnect means - C=Circuit Breaker, D=Non-fused disconnect switch, F=Fused disconnect switch

kvar rating

Enclosure type - G=NEMA 1, R=NEMA 3R, D=Dust proof

Voltage - 2 = 240V, 4 = 480V, 6 = 600V

Model - D=DynaComp

Type PQF Power^{IT} LV Active Filter



Power^{IT} Active Filter Type PQF

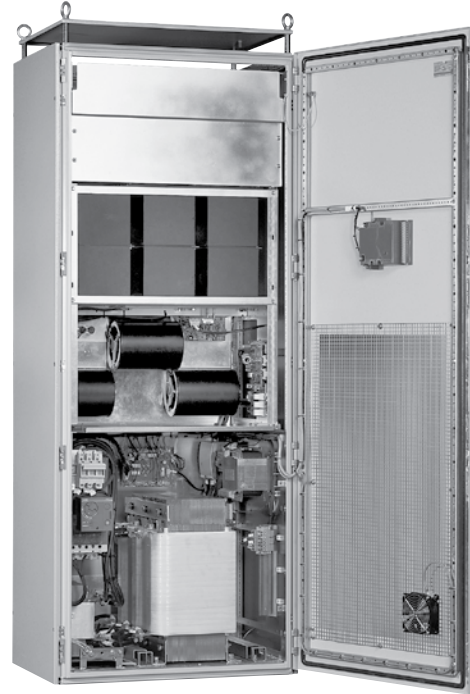

Typical application

Power distribution systems which require multiple harmonic elimination or power factor correction.

Product description

The power quality filters developed by ABB are active filters offering unprecedented ability to eliminate harmonics from the network. The PQF eliminates harmonics in a controlled way. It is easy to expand and adapt to changes in the network. The PQF monitors the line current in real time and processes the measured harmonics as digital signals in

a high-power DSP (Digital Signal Processor). The output of the DSP controls PWM (Pulse Width Modulated) power modules that through line reactors inject harmonic currents with exactly the opposite phase to those that are to be filtered. The net effect is an elimination of the harmonics and a clean sine-wave as seen by the feeding transformer. The PQF is UL approved (UL File # E254288).

PQF sizing information

Consult your local ABB representative or the factory for assistance in sizing your PQF filter.

General information Power quality filter

Harmonics and power quality

Harmonics caused by non-linear electrical loads such as variable speed drives, rectifiers, UPS's, computers, etc., are a growing problem both for electricity suppliers and users.

Harmonics can lead to serious problems:

- overheating of cables, motors and transformers
- damage to sensitive equipment
- tripping of circuit breakers
- blowing of fuses
- premature aging of the installation

The ABB solution: PQF power quality filters

The ABB Power Quality Filter offers unprecedented ability to clean the network from harmonics. The PQF actively eliminates the harmonics present in the supply system in a controlled way. It is insensitive to large network impedance changes due to change in network topology like paralleling of sources, or switching between mains supply and generator operation.

The PQF monitors the line current in real time and processes the measured harmonics as digital signals in a high-power multi-DSP (Digital Signal Processor) based system. The digital controller generates Pulse Width Modulated (PWM) signals that drive IGBT power modules which through line reactors inject harmonic currents in the network with exactly the opposite phase to the components that are to be filtered.

The PQF also offers communication facilities with the customer's existing communication network. This feature which uses Modbus RTU, allows the PQF to be easily monitored and controlled from a remote location. The Modbus communication feature can be used by means of an RS-232 to RS-485 converter (optional).

Advantages of the PQF

- Filters up to 20 harmonics simultaneously
- Filters up to the 50th harmonic
- Harmonic attenuation factor better than 97%
- Fulfilment of International Guidelines like G5/4, IEEE 519, etc
- Filters with closed loop control for best accuracy
- Is not overloadable
- Has a programmable filtering strategy and free choice of harmonics selection
- Fault and event logging with real time stamp
- Direct connection up to 690V
- Top or bottom cable entry (optional for PQFI)
- Easy commissioning – Auto-detection of CT Polarity
- May filter without generation of reactive power
- May generate reactive power and control power factor
- May balance the load current across the phases
- Has programmable task priorities
- Does not require detailed network analysis
- Does not require special CTs
- Is easy to extend on site
- Comes factory tested
- Auto-adaptation to network impedance changes
- Optical fibre isolation between power and control stages
- Programmable stand-by and re-start functions
- Programmable digital I/O interface
- Modbus RTU communication compatible
- Two sets of compensation parameters for different load type compensation.

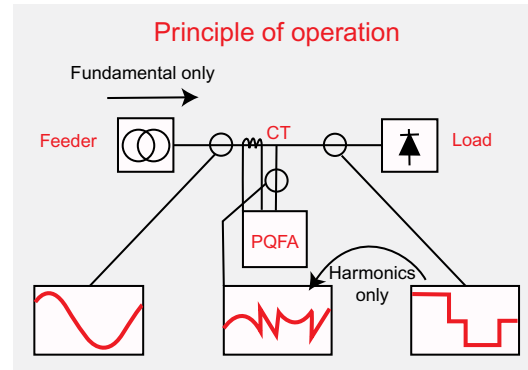

Line current – Initial situation

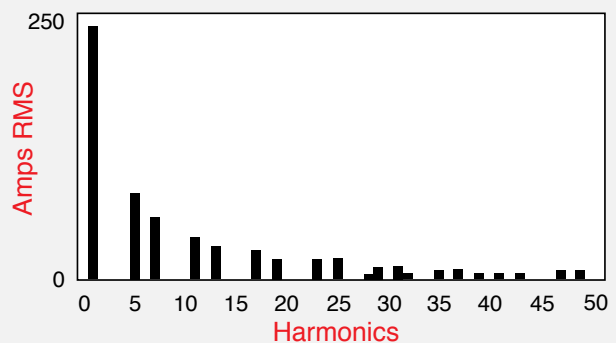

Filter current – Filter running

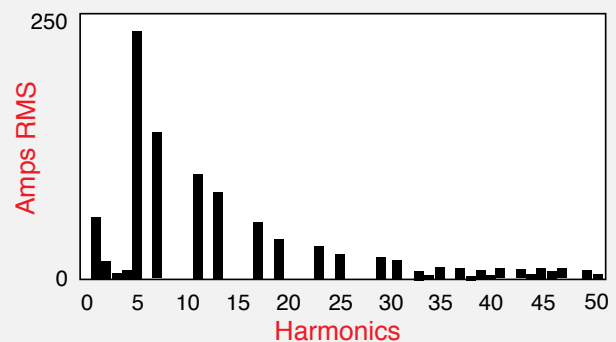

Line current – Filter running

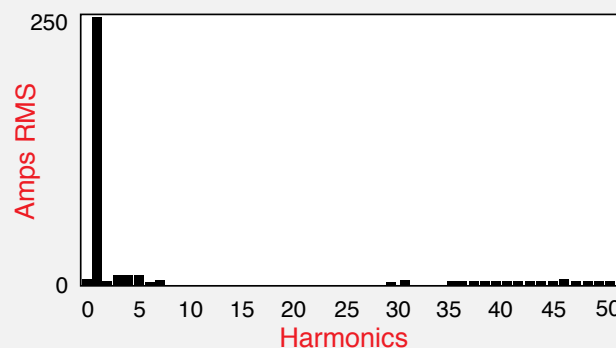

General information Power quality filter

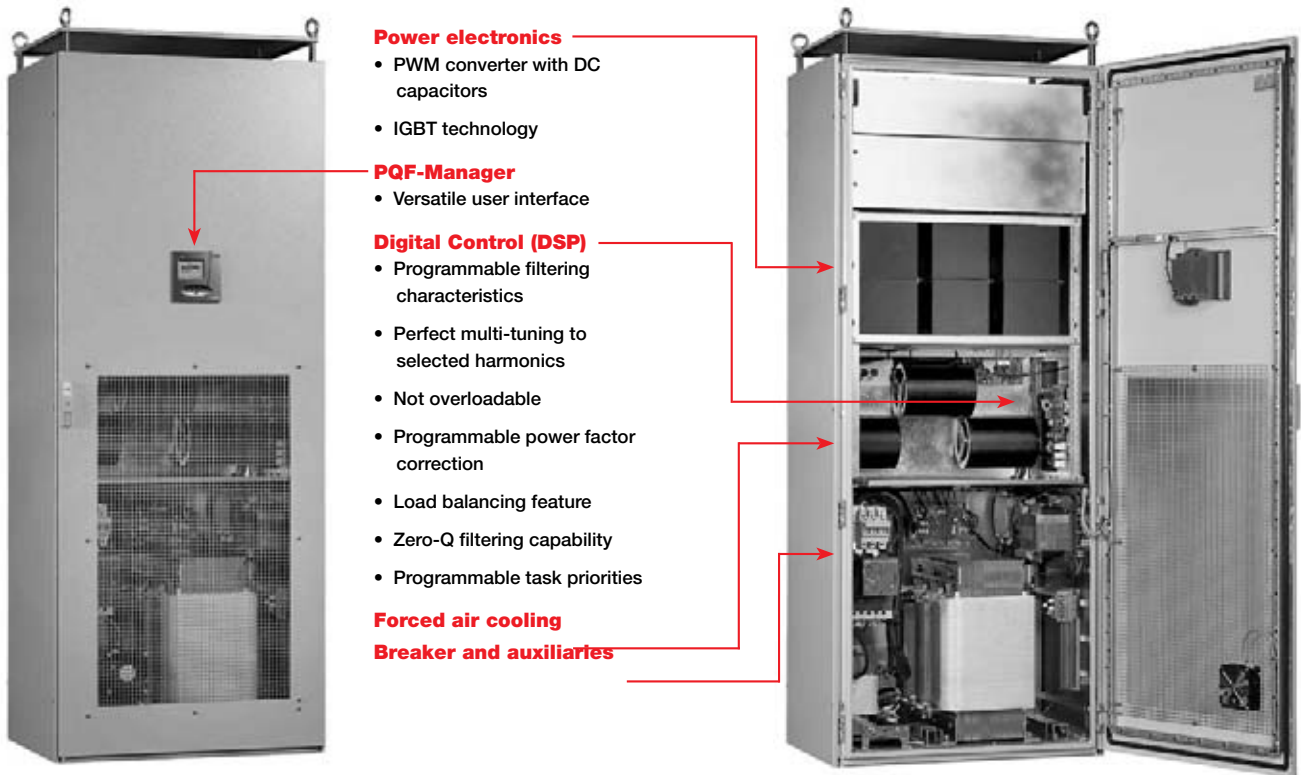

PQF ratings and capabilities

Power modules for the PQF are available with voltage ratings up to 600V for 50 or 60 Hz. The maximum thermal rating of a single cubicle is 450 A rms. Absolute harmonic filtering capability also depends on the content of higher harmonics with the filtering capability following common load spectra. The reactive power compensation capacity per module is given by the thermal rating.

On site extensions are easily made by adding cubicle sections to a maximum of eight cubicles. Several PQF may operate together on the same network.

Systems for 50 Hz and 60 Hz applications can filter 20 different harmonics from the 2nd to the 50th harmonic.

Selected harmonics can be filtered completely, or to a predescribed level defined in absolute or relative terms.

Reactive power compensation may be chosen and controlled to a desired power factor.

The PQF is programmed through the PQF-Manager graphical user interface. Optional PQF-Link software enables users to program the active filter through an RS232 port using a standard PC.

UL File # E254288

The PQF-Manager

The PQF-Manager is the Graphical User Interface provided in all the PQF types as a standard accessory. It offers direct control, programming, monitoring capabilities without a PC, communication facilities and detailed fault and event logging with real time stamp. The PQF-Manager (144 x 144 mm), fitted in the front panel of the PQF with its large LCD screen display (64 x 132 pixel) makes operating the filter very convenient.



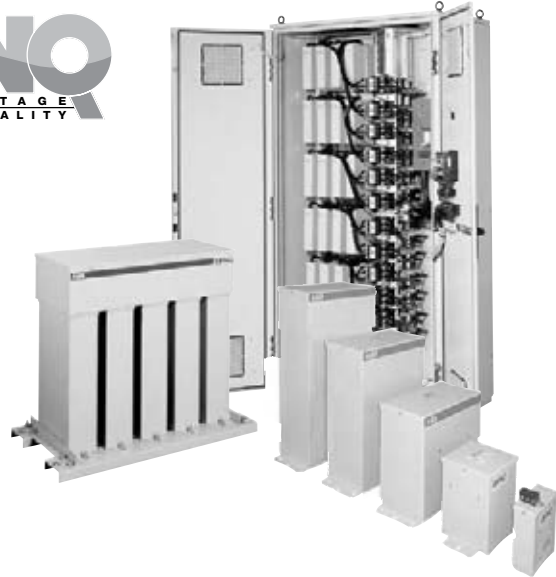

Index

Application and installation	20.4 - 20.49
Capacitor installation locations	20.46
Extract from NEC, Separate overcurrent protection	20.59
General information	20.44 - 20.45
Harmonic phenomena	20.50 - 20.52
Sizing capacitors at the motor load	20.53 - 20.56
Typical recommended ratings of cables & protected devices	20.57 - 20.58

Basic Concepts

Most loads on an electrical distribution system can be categorized into three types:

- Resistive
- Inductive
- Capacitive

On modern systems, the most common is the inductive load. Typical examples include transformers, fluorescent lighting and AC induction motors.

A common characteristic of these inductive loads is that they utilize a winding in order to operate. This winding produces an electromagnetic field which allows the motor or transformer to function and requires a certain amount of electrical power to maintain this electromagnetic field.

All inductive load require two kinds of power to function properly:

- Active power (kW) - actually performs the work
- Reactive power (kvar) - sustains the electro-magnetic field

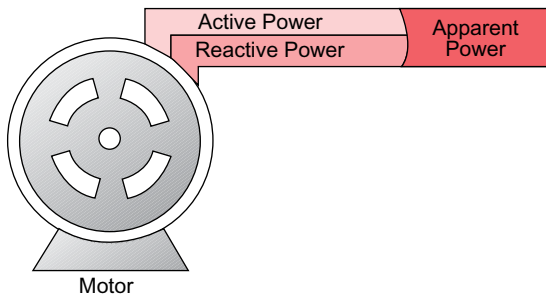

Fig. 1

One common example of reactive power can be seen in an unloaded AC motor. When all load is removed from the motor, one might expect the no-load current to drop near zero. In truth, however, the no-load current will generally show a value between 25% and 30% of full load current. This is because of the continuous demand for magnetizing current by any inductive load.

Active power is the total power indicated on a wattmeter. Apparent power is the combination of reactive and active power.

What is Power Factor?

Power factor is the relationship between working (active) power and total power consumed (apparent power). Essentially, power factor is a measurement of how effectively electrical power is being used. The higher the power factor, the more effectively electrical power is being used.

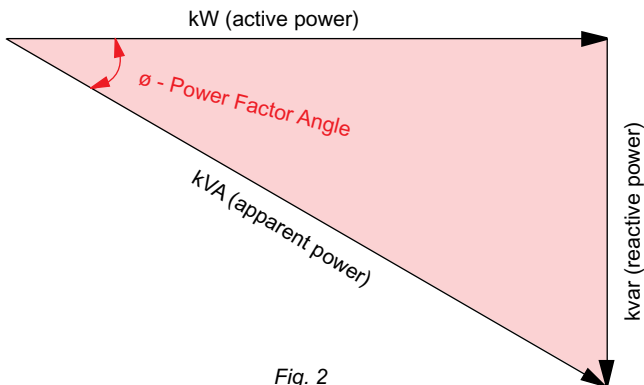

Fig. 2

Fig. 2

A distribution system's operating power is composed of two parts: Active (working) power and reactive (non-working magnetizing) power. The ACTIVE power performs the useful work . . . the REACTIVE power does not. It's only function is to develop magnetic fields required by inductive devices.

Generally, power factor decreases (phi increases) with increased motor load. This geometric relationship of apparent power to active power is traditionally expressed by the right triangle relationship of:

$$\text{Cos phi} = \text{p.f.} = \text{kW/kVA}$$

Why Improve Low Power Factor?

Low power factor means poor electrical efficiency. The lower the power factor, the higher the apparent power drawn from the distribution network.

When low power factor is not corrected, the utility must provide the nonworking reactive power IN ADDITION to the working active power. This results in the use of larger generators, transformers, bus bars, wires, and other distribution system devices that otherwise would not be necessary. As the utility's capital expenditures and operating costs are going to be higher, they are going to pass these higher expenses to industrial users in the form of power factor penalties.

Advantages of Improving Low Power Factor — Saving Money!!

- High power factor eliminates utility power factor penalties.
- High power factor reduces the heating losses of transformers and distribution equipment, prolonging life of the equipment.
- High power factor stabilizes voltage levels.
- Increased system capacity

Figure 3 illustrates the relationship of power factor to total current consumed. With a power factor of 1.0 given a constant load, the 100% figure represents the required useful current.

As the power factor drops from 1.0 to .9, power is used less effectively. Therefore, 10% more current is required to handle the same load.

A power factor of .7 requires approximately 43% more current; and a power factor of .5 requires approximately 100% (twice as much!!) to handle the same load.

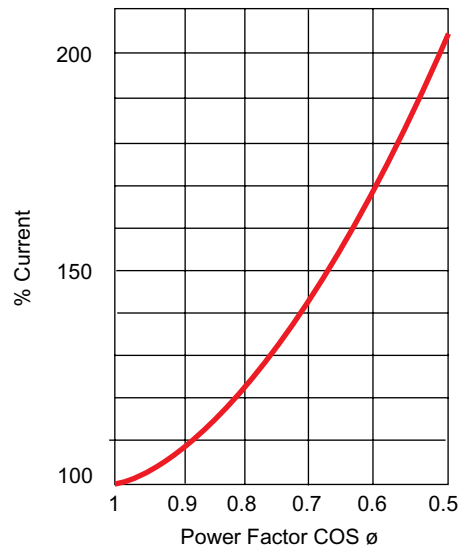

Fig. 3

How Power Factor Correction Capacitors Solve the Problem of Low Power Factor

Lower power factor is a problem that can be solved by adding power factor correction capacitors to the plant distribution system. As illustrated in Fig. 4, power factor correction capacitors work as reactive current generators “providing” needed reactive power (kvar) to the power supply. By supplying their own source of reactive power, the industrial user frees the utility from having to supply it; therefore, the total amount of apparent power (kVA) supplied by the utility will be less.

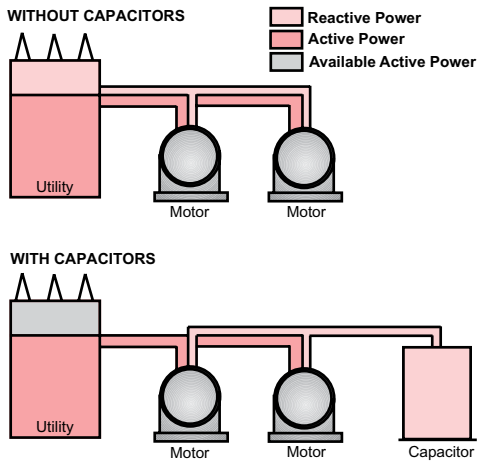

Fig. 4

Power factor correction capacitors reduce the total current drawn from the distribution system and subsequently increase system capacity by raising the power factor level.

Capacitor Rating

Power factor correction capacitors are rated in electrical units called “vars”. One var is equivalent to one volt ampere of reactive power. Vars are units of measurement for indicating how much reactive power the capacitor will supply.

As reactive power is usually measured in thousands of vars, the letter “k” (abbreviation for “kilo”, meaning thousands) precedes the var creating the more familiar “kvar” term.

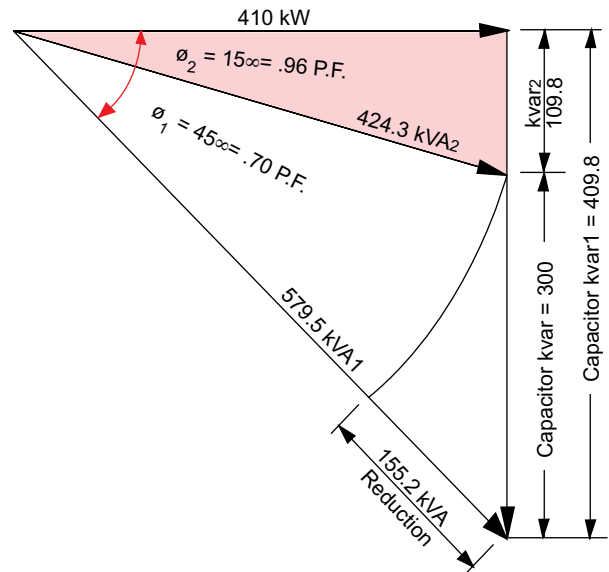

Fig. 5

The capacitor kvar rating shows how much reactive power the capacitor will supply. Each unit of the capacitor’s kvar will decrease the inductive reactive power demand (magnetizing demand) by the same amount.

EXAMPLE:

A low voltage network requires 410 kW active power at full load, and the power factor is measured to be .70. Therefore, the system’s full load consumption of apparent power is 579.5 kVA. If 300 kvar of capacitive reactive power is installed, the power factor will rise to .96 and the kVA demand will be reduced from 579.5 to 424.3 kVA. See Fig. 5.

Capacitor installation locations

Where Should Power Factor Correction Capacitors Be installed in a distribution system?

As shown in Fig. 6, several options exist for the connection of power factor correction capacitors on the low voltage distribution system.

Option A: On the secondary of the overload relay

Advantages: This is the most efficient location since the reactive power (kvar) is produced at the same spot where it is consumed. Line losses and voltage drop are minimized. The capacitor is switched automatically by the motor starter, so it is only energized when the motor is running. No separate switching device or overcurrent protection is required because of the presence of the motor starter components.

Care must be taken in setting the overload relay since the capacitor will bring about a reduction in amps through the overload. Therefore, to give the same protection to the motor, the overload relay's trip setting should be readjusted or the heater elements should be resized. Refer to page 6.12 for line current reduction in percent of FLA.

Option B: Between the contactor and the overload relay

The advantages are the same as Option A except the overload relay can now be set to the full load amps as shown on the motor nameplate. This mounting location is normally preferred by motor control center and switchgear builders since the overload setting is simplified.

Option C: Between the circuit breaker and the contactor

Advantages: Since the capacitor is not switched by the contactor, it can act as a central kvar source for several motors fed by the same circuit breaker. This location is recommended for jogging, plugging and reversing applications.

Since the capacitor remains energized even when the motor or motors are not running, there exists the possibility of overcorrection and leading power factor during lightly loaded periods. Losses are higher than with Options A & B as the reactive current must be carried further.

LOCATIONS FOR CAPACITORS IN MOTOR CIRCUITS

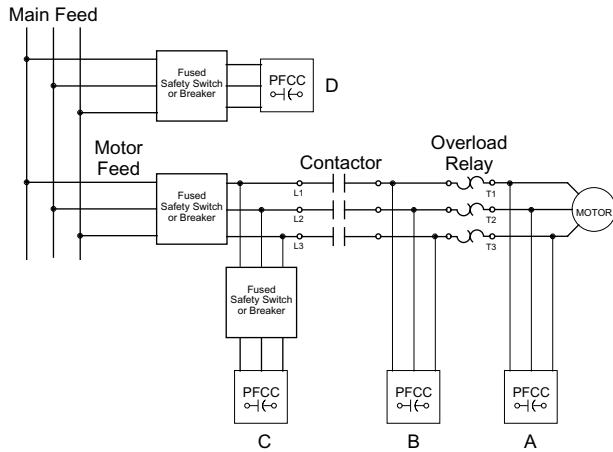

Fig. 6

Option D: As a central compensation source connected to the main distribution bus

Advantages: Of the four options, this is the most cost efficient because it uses a few large kvar capacitors rather than many small units.

A primary disconnect must be provided for switching and overcurrent protection. As with Option C, a real possibility of overcompensation exists during lightly loaded periods unless some form of automatic control is incorporated. Automatic control can be provided by ABB automatic capacitor banks.

Application and Installation

Temperature and Ventilation

Capacitors should be located in areas where the surrounding ambient temperature does not exceed 40° C and where there is adequate ventilation. As capacitors always operate at full load and generate heat of their own, maximum heat dissipation must be provided to ensure long operating life.

Line frequency and operating voltage are factors that can cause capacitor temperature to rise.

- **Line Frequency** - Assuming the line frequency of the capacitor matches the frequency of the incoming service, line frequency is not a concern since it is constant in modern power systems.
- **Operating Voltage** - Capacitor overheating at a normal operating voltage and with adequate ventilation seldom occurs. However, when the voltage exceeds 110% of the capacitor rating, overheating and resultant damage can happen.

When the operating voltage exceeds 110% of the capacitor's rated voltage, the line voltage should be reduced or the capacitor taken off line.

This overvoltage problem is exactly why, when determining the required kvar capacitance for a distribution system, a person should always "undersize" a capacitor's kvar rating... too much capacitance means overvoltage... too much overvoltage means excessive heat... and excessive heat can be damaging to the capacitor unit!!!

Special Applications

Care should be taken when power factor correction capacitors are used in the following applications:

- Plugging and jogging applications
- Frequent starts
- Crane or elevator motors where the load may drive the motor
- Multi-speed motors
- Motors involving open transition reduced voltage starting
- Reversing starters if they reverse more frequently than once per minute

ABB contactor kvar ratings

Contactors	208V	240V	480V	600V	Max amps
UA26	3.5	4.0	8.0	10.0	10
UA30	7.0	8.0	16.5	20.5	20
UA50	10.5	12.5	25.0	31.0	30
UA75	21.5	25.0	50.0	62.0	60
UA95	25.0	29.0	58.0	72.0	70
UA110	28.5	33.0	66.0	83.0	80
A145	43	50	100	125	120
A185	57	66	133	166	160
A210	66	77	153	192	185
A260	75	87	174	218	210
A300	88	101	203	254	245
AF400	119	137	274	343	330
AF460	142	164	329	410	396
AF580	178	205	411	514	495
AF750	214	247	495	618	595

Discharging Time

Power factor capacitors need a minimum of one minute to discharge. Afterwards, it is always recommended that the terminals be short-circuited to ground before touching.

Typical Capacitor Specifications

The following guidelines can be used when specifying capacitors.

SPECIFICATIONS FOR CAPACITORS

600 Volts and Below

Furnish and install where indicated power factor correction capacitors of the size, voltage rating, and enclosure type shown on the drawings.

(OPTIONAL) All motors of _____ horsepower and above shall have individual power factor correction capacitors energized with the motor.

All capacitors shall be the self healing metallized-film type filled with vermiculite, a dry NONFLAMMABLE filler material; oil-filled capacitors will not be acceptable. Discharge resistors shall be provided to automatically discharge the capacitor to less than 50 volts within one minute after de-energization. An internal ground lug shall be provided. The capacitors shall withstand 135% of rated current continuously, 110% of rated voltage continuously; and an ambient temperature range of -40°C to +40°C.

Losses shall be less than 0.5 watts per kvar. Each element shall be individually protected and the enclosure shall be filled with a dry, non-toxic, nonflammable insulating material. The capacitors shall be UL Listed and CSA approved. Capacitors shall be ABB or equivalent.

Application and installation

Wiring diagrams for Autotransformer, part-winding, wye-delta, multi-speed

Power Factor Correction Capacitor connection locations

Autotransformer

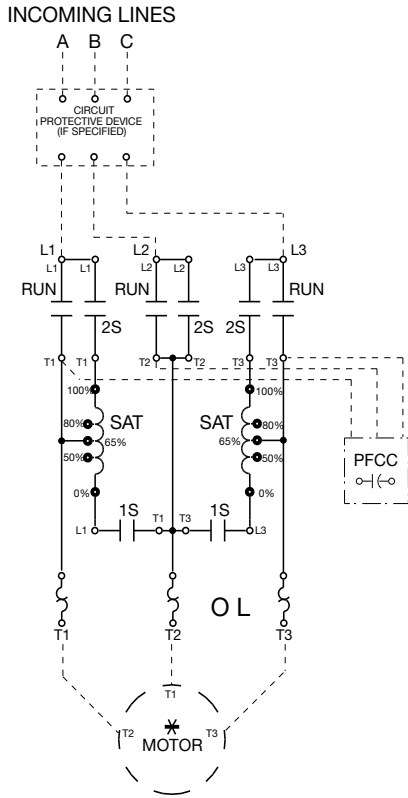

Part-winding

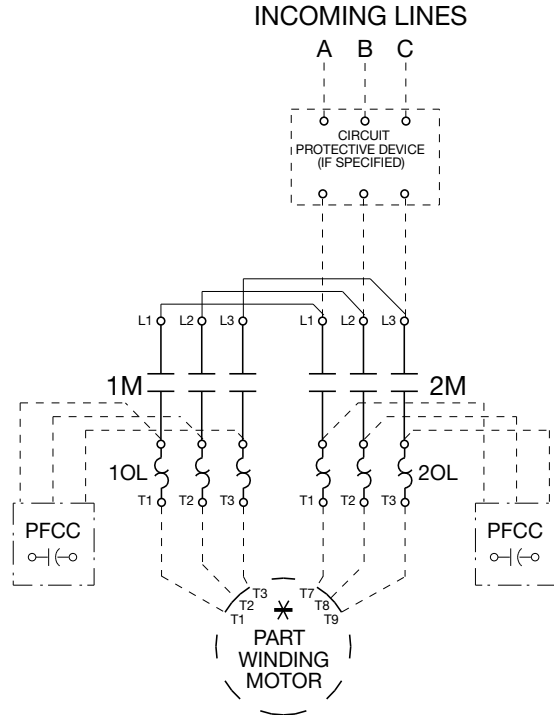

Wye-delta

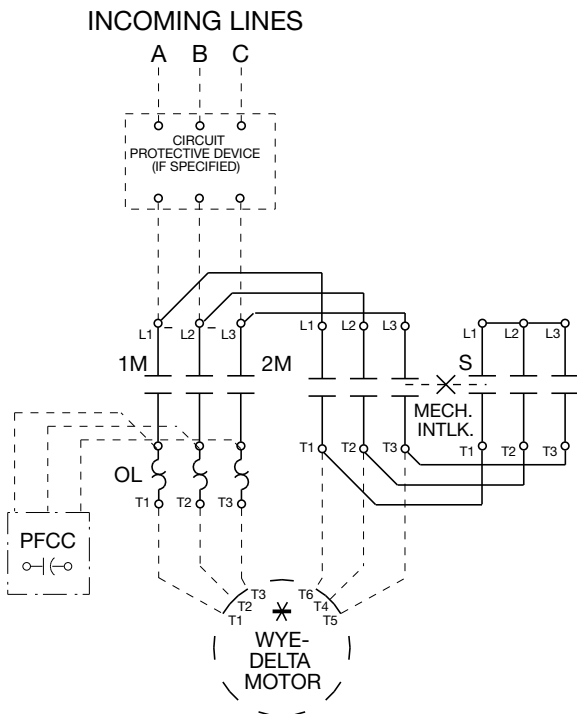

2 Speed, 2 winding

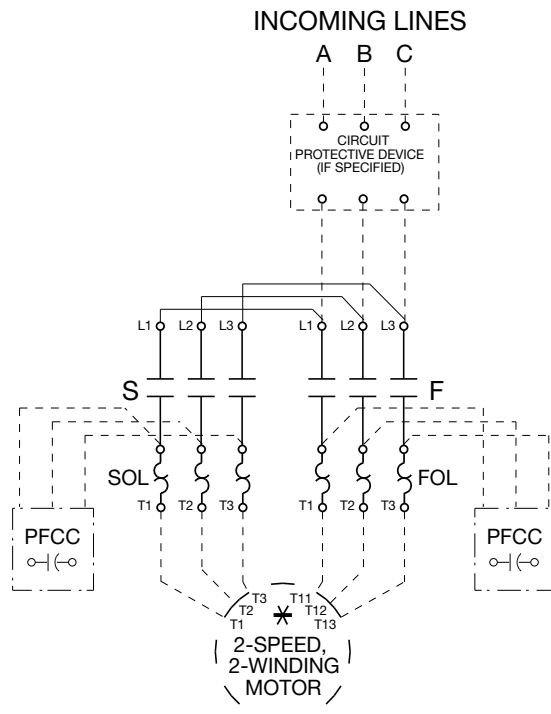

Application and installation

Wiring diagrams for Softstarters

Softstarter

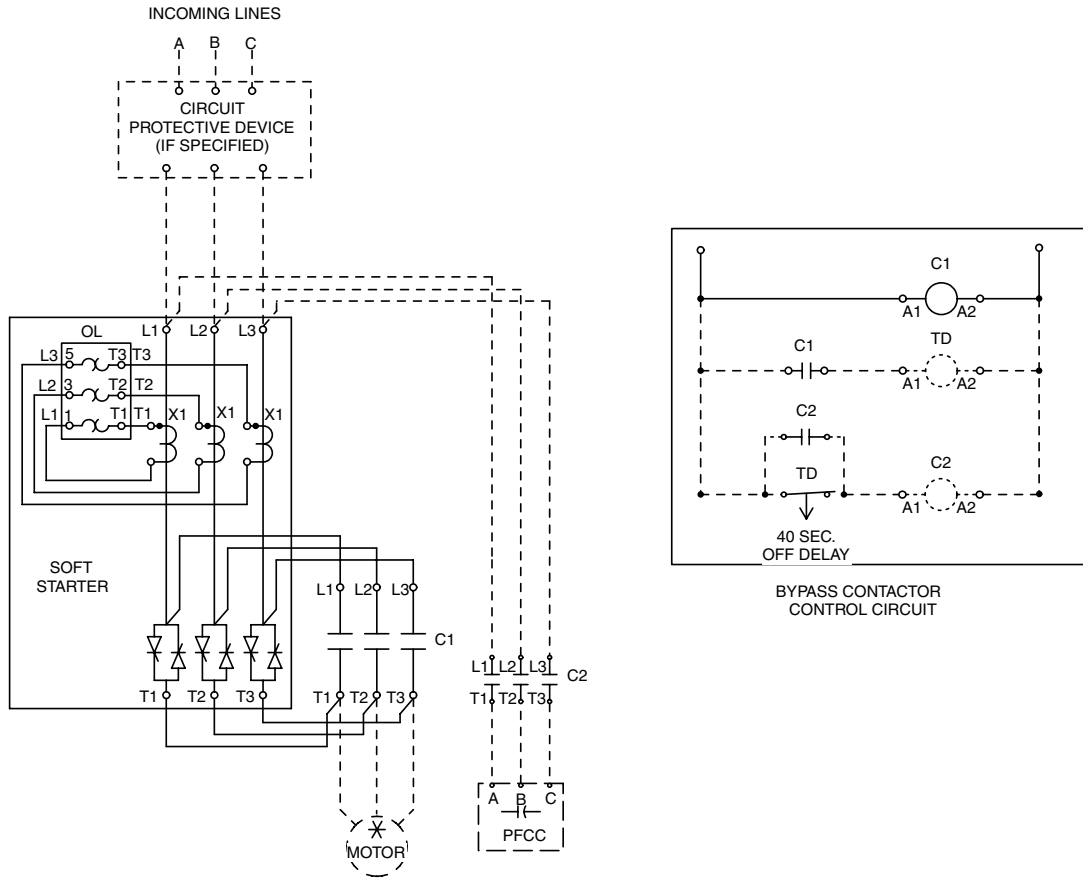

Problems Created by Harmonics

- Excessive heating and failure of capacitors, capacitor fuses, transformers, motors, fluorescent lighting ballasts, etc.
- Nuisance tripping of circuit breaker or blown fuses
- Presence of the third harmonic & multiples of the 3rd harmonic in neutral grounding systems may require the derating of neutral conductors
- Noise from harmonics that lead to erroneous operation of control system components
- Damage to sensitive electronic equipment
- Electronic communications interference

Any device with non-linear operating characteristics can produce harmonics in your power system. If you are currently using equipment that can cause harmonics or have experienced harmonic related problems, capacitor reactor or filter bank equipment may be the solution. The following is a discussion of harmonics; the characteristics of the problem; and a discussion of our solution.

Origins of Harmonic Distortion

The ever increasing demand of industry and commerce for stability, adjustability and accuracy of control in electrical equipment led to the development of relatively low cost power diodes, thyristors, SCRs and other power semi-conductors. Now used widely in rectifier circuits for U.P.S. systems, static converters and A.C. & D.C. motor control, these modern devices replace the mercury arc rectifiers of earlier years and create new and challenging conditions for the power engineer of today. Although solid state devices, such as the thyristor, have brought significant improvements in control designs and efficiency, they have the disadvantage of producing harmonic currents.

Harmonic currents can cause a disturbance on the supply network and adversely affect the operation of other electrical equipment including power factor correction capacitors.

We are concentrating our discussions on harmonic current sources associated with solid state power electronics but there are actually many other sources of harmonic currents. These sources can be grouped into three main areas:

1. Power electronic equipment: Variable speed drives (AC VFD's, DC drives, PWM drives, etc.); UPS systems, rectifiers, switch mode power supplies, static converters, thyristor systems, diode bridges, SCR controlled induction furnaces and SCR controlled systems.
2. Arcing equipment: Arc furnaces, welders, lighting (mercury vapor, fluorescent)
3. Saturable devices: Transformers, motors, generators, etc. The harmonic amplitudes on these devices are usually insignificant compared to power electronic and arcing equipment, unless saturation occurs.

Waveform

Harmonics are sinusoidal waves that are integral multiples of the fundamental 60 Hz waveform (i.e., 1st harmonic =

60 Hz; 5th harmonic = 300 Hz). All complex waveforms can be resolved into a series of sinusoidal waves of various frequencies, therefore any complex waveform is the sum of a number of odd or even harmonics of lesser or greater value. Harmonics are continuous (steady-state) disturbances or distortions on the electrical network and are a completely different subject or problem from line spikes, surges, sags, impulses, etc., which are categorized as transient disturbances.

Transient problems are usually solved by installing suppression or isolation devices such as surge capacitors, isolation transformers or M.O.V.s. These devices will help solve the transient problems but will not affect the mitigation of low order harmonics or solve harmonic resonance problems.

Harmonic Content

Thyristor and SCR converters are usually referred to by the number of DC current pulses they produce each cycle. The most commonly used are 6 pulse and 12 pulse.

There are many factors that can influence the harmonic content but typical harmonic currents, shown as a percentage of the fundamental current, are given in the below table. Other harmonics will always be present, to some degree, but for practical reasons they have been ignored.

Order of harmonic	Typical percentage of harmonic current	
	6 Pulse	12 pulse
1	100	100
5	20	—
7	14	—
11	9	9
13	8	8
17	6	—
19	5	—
23	4	4
25	4	4

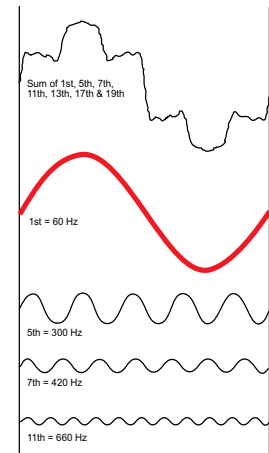

Fig. 7

Harmonic Overloading of Capacitors

The impedance of a circuit dictates the current flow in that circuit. As the supply impedance is generally considered to be inductive, the network impedance increases with frequency while the impedance of a capacitor decreases. This causes a greater proportion of the currents circulating at frequencies above the fundamental supply frequency to be absorbed by the capacitor, and all equipment associated with the capacitor.

In certain circumstances, harmonic currents can exceed the value of the fundamental (60 Hz) capacitor current. These harmonic problems can also cause an increased voltage across the dielectric of the capacitor which could exceed the maximum voltage rating of the capacitor, resulting in premature capacitor failure.

Harmonic Resonance

The circuit or selective resonant frequency is reached when the capacitor reactance and the supply reactance are equal.

Whenever power factor correction capacitors are applied to a distribution network, which combines capacitance and inductance, there will always be a frequency at which the capacitors are in parallel resonance with the supply.

If this condition occurs on, or close to, one of the harmonics generated by solid state control equipment, then large harmonic currents can circulate between the supply network and the capacitor equipment. These currents are limited only by the damping resistance in the circuit. Such currents will add to the

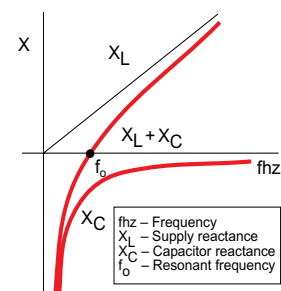

Fig. 8

harmonic voltage disturbance in the network causing an increased voltage distortion.

This results in a higher voltage across the capacitor and excessive current through all capacitor components. Resonance can occur on any frequency, but in general, the resonance we are concerned with is on, or close to, the 5th, 7th, 11th and 13th harmonics for 6 pulse systems. See Fig. 8.

Avoiding Resonance

There are a number of ways to avoid resonance when installing capacitors. In larger systems it may be possible to install them in a part of the system that will not result in a parallel resonance with the supply. Varying the kvar output rating of the capacitor bank will alter the resonant frequency. With capacitor switching there will be a different resonant frequency for each step. Changing the number of switching steps may avoid resonance at each step of switching. See Fig. 9.

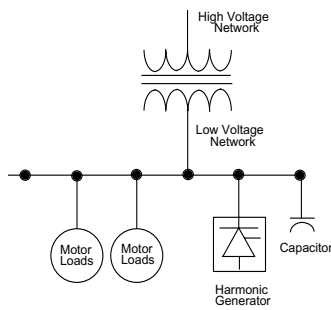

Fig. 9

Overcoming Resonance

If resonance cannot be avoided, an alternative solution is required. A reactor must be connected in series with each capacitor such that the capacitor/reactor combination is inductive at the critical frequencies but capacitive at the fundamental frequency. To achieve this, the capacitor and series connected reactor must have a tuning frequency below the lowest critical order of harmonic, which is usually the 5th. This means the tuning frequency is in the range of 175 Hz to 270 Hz, although the actual frequency will depend upon the magnitude and order of the harmonic currents present.

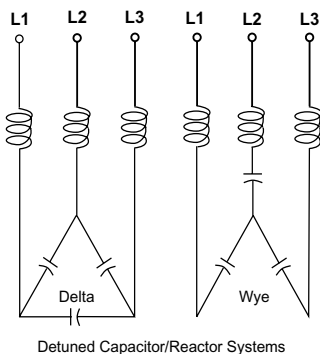

Fig. 10

The addition of a reactor in the capacitor circuit increases the fundamental voltage across the capacitor.

Therefore, care should be taken when adding reactors to existing capacitors. See Fig. 10.

Reduction of Harmonic Distortion

Harmonic currents can be significantly reduced in an electrical system by using a harmonic filter.

In its basic form, a filter consists of a capacitor connected in series with a reactor tuned to a specific harmonic frequency. In theory, the impedance of the filter is zero at the tuning frequency; therefore, the harmonic current is absorbed by the filter. This, together with the natural resistance of the circuit, means that only a small level of harmonic current will flow in the network.

Types of Filters

The effectiveness of any filter design depends on the reactive output of the filter, tuning accuracy and the impedance of the network at the point of connection.

Harmonics below the filter tuning frequency will be amplified. The filter design is important to ensure that distortion is not amplified to unacceptable levels. Where there are several harmonics present, a filter may reduce some harmonics while increasing others. A filter for the 7th harmonic creates a parallel

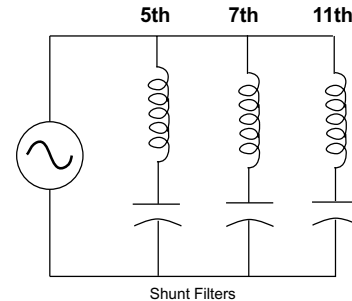

Fig. 11

resonance in the vicinity of the 5th harmonic with magnification of the existing 5th harmonic; therefore, a 7th harmonic filter requires a 5th harmonic

filter. See Fig. 11. Consequently, it is often necessary to use a multiple filter design where each filter is tuned to a different frequency. Experience is extremely important in the design of such filters to ensure:

- the most efficient and cost effective solution is selected;
- no adverse interaction between the system and the filter.

Load Alteration

Whenever load expansion is considered, the network is likely to change and existing filter equipment should be evaluated in conjunction with the new load condition. It is not recommended to have two or more filters tuned to the same frequency connected on the same distribution system. Slight tuning differences may cause one filter to take a much larger share of the harmonic distortion. Or, it may cause amplification of the harmonic order which the equipment has been designed to reduce. When there is a need to vary the power factor correction component of a harmonic filter, careful consideration of all load parameters is necessary.

Harmonic Analysis

The first step in solving harmonic related problems is to perform an analysis to determine the specific needs of your electrical distribution system. To determine capacitor and filter requirements, it is necessary to establish the impedance of the supply network and the value of each harmonic current. Capacitor, reactor and filter bank equipment are then specified under very detailed and stringent computer analysis to meet your needs.

Your ABB Solution to Harmonics

ABB is the world's largest manufacturer of dry type low voltage capacitors! ABB Control Inc. utilizes this experience in recommending three options to solve the problems associated with applying capacitors to systems having harmonic distortion:

- Apply the correct amount of capacitance (kvar) to the network to avoid resonance with the source. This may be difficult, especially in automatic systems as the capacitance is always changing. This solution usually means connecting less capacitance to the system than is actually needed for optimum power factor correction.
- Install reactors in series with capacitors to lower the resonance below critical order harmonics; i.e., 5th, 7th, 11th & 13th. This design tunes the resonant frequency of the system well below the critical harmonic and is called an anti-resonance bank. This solution allows the capacitors to operate in a harmonic environment.

3. Filters are recommended if a problem exists with harmonic distortion before the application of power factor correction, or if the harmonic distortion is above the limits recommended in IEEE 519, "Guide for Harmonic Control and Reactive Compensation of Static Power Converters". (The recommended limits for voltage distortion in IEEE 519 are presently 5% for general applications.) Tuned filters sized to reduce the harmonic distortion at critical frequencies have the benefits of correcting the power factor and improving the network power quality.

With our knowledge of harmonics, ABB provides a complete range of products from individual capacitors, fixed banks and automatic banks, to power filter systems. All these products utilize dry type low voltage ABB power factor correction capacitor elements which are self-healing for internal faults.

To maintain stringent quality control standards, most control components found in automatic and anti-resonance filter bank products are also ABB products. These products include contactors, circuit breakers, control relays, disconnect switches, power factor relays and pushbutton devices.

ABB Capacitor Features & Services

Every ABB Control low voltage capacitor product incorporates our unique dry type design. Therefore, environmental and personnel concerns associated with leakage or flammability of conventional oil-filled units are eliminated. Other features include:

- Patented Sequential Protection System includes dry, self-healing design; internally protected elements; and dry, non-flammable vermiculite filler
- Individual units, fixed and automatic capacitor bank designs, 208-600V
- Automatic and fixed tuned or anti-resonance capacitor banks
- Power factor and harmonic studies
- UL and CSA

Sizing capacitors at the motor load Using formulas

Sizing Capacitors at the Motor Load

When the determination is made that power factor correction capacitors ARE a good investment for a particular electrical system, you need to know:

- How many capacitors are needed?
- What sizes are appropriate?

The capacitor provides a local source of reactive current. With respect to inductive motor load, this reactive power is the magnetizing or “no-load current” which the motor requires to operate.

A capacitor is properly sized when its full load current rating is 90% of the no-load current of the motor. This 90% rating avoids overcorrection and the accompanying problems such as overvoltages.

One Selection Method: Using Formulas

If no-load current is known . . .

The most accurate method of selecting a capacitor is to take the no-load current of the motor, and multiply by .90 (90%). Take this resulting figure, turn to the appropriate catalog page, and determine which kvar size is needed, catalog number, enclosure type, and price.

EXAMPLE: Size a capacitor for a 100hp, 460V 3-phase motor which has a full load current of 124 amps and a no-load current of 37 amps.

1. Multiply the no-load current figure of 37 amps by 90%.

37 no load amps X 90% = 33 no load amps

2. Turning to the catalog page for 480 volt, 3-phase capacitors, find the closest amp rating to, but NOT OVER 33 amps. See Table 1, sample catalog pricing chart. Per the sample chart the closest amperage is 32.5 amps. The proper capacitor unit, then is 27 kvar and the appropriate catalog number depends on the type enclosure desired.

If the no load current is not known . . .

If the no-load current is unknown, a reasonable estimate for 3-phase motors is to take the full load amps and multiply by 30%. Then take that figure and multiply times the 90% rating figure being used to avoid overcorrection and overvoltages.

EXAMPLE: Size a capacitor for a 75hp, 460V 3-phase motor which has a full load current of 92 amps and an unknown no-load current.

1. First, find the no-load current by multiplying the full load current times 30%.

92 (full load amps) X 30% = 28 estimated no-load amps

2. Multiply 28 no-load amps by 90%.

28 no-load amps X 90% = 25 no-load amps

3. Now examine the capacitor pricing and selection chart for 480 volt, 3-phase capacitors. Refer again to Table 1. Here it will be seen that the closest capacitor to 25 amps full load current without going over is a 20 kvar unit, rated at 24.1 amps.

4. The correct selection, then, is 20 kvar!

NOTE

The formula method corrects power factor to approximately .95

TABLE 1
480 VOLT, 60 Hz., 3-Phase

Enclosure Size	kvar Rating	Rated Current Per Phase	Approx. Shipping Weight (Lbs.)	Indoor – Nema 1	Outdoor – Nema 3R	Indoor – Nema 12
				Catalog Number	Catalog Number	Catalog Number
	1.5	1.8	8	C484G1.5	C484R1.5	C484D1.5
	2	2.4	8	C484G2	C484R2	C484D2
	2.5	3.0	8	C484G2.5	C484R2.5	C484D2.5
	3	3.6	8	C484G3	C484R3	C484D3
	4.8	4.8	8	C484G4.8	C484R4.8	C484D4.8
	6	6	13	C484G6	C484R6	C484D6
	7.5	7.5	13	C484G7.5	C484R7.5	C484D7.5
	9	9	13	C484G9	C484R9	C484D9
	11.25	11.25	13	C484G11.25	C484R11.25	C484D11.25
	13.5	13.5	13	C484G13.5	C484R13.5	C484D13.5
	15.75	15.75	13	C484G15.75	C484R15.75	C484D15.75
	18	18	13	C484G18	C484R18	C484D18
	19	22.8	13	C484G19	C484R19	C484D19
	20	24.1	13	C484G20	C484R20	C484D20
	21	25.3	13	C484G21	C484R21	C484D21
	22	26.5	13	C484G22	C484R22	C484D22
	22.5	27.1	13	C484G22.5	C484R22.5	C484D22.5
	24	28.9	13	C484G24	C484R24	C484D24
	25	30	13	C484G25	C484R25	C484D25
	27	32.5	13	C484G27	C484R27	C484D27

Sizing capacitors at the motor load Using charts

An Alternate Selection Method – Using Charts

TABLE 2: Suggested Maximum Capacitor Ratings for T-Frame NEMA Class B Motors

Induction motor rating (HP)	NOMINAL MOTOR SPEED											
	3600 R/Min		1800 R/Min		1200 R/Min		900 R/Min		720 R/Min		600 R/Min	
	Capacitor rating (kvar)	Line current reduction (%)	Capacitor rating (kvar)	Line current reductions (%)	Capacitor rating (kvar)	Line current reduction (%)	Capacitor rating (kvar)	Line current reduction (%)	Capacitor rating (kvar)	Line current reduction (%)	Capacitor rating (kvar)	Line current reduction (%)
3	1.5	14	1.5	23	2.5	28	3	38	3	40	4	40
5	2	14	2.5	22	3	26	4	31	4	40	5	40
7.5	2.5	14	3	20	4	21	5	28	5	38	6	45
10	4	14	4	18	5	21	6	27	7.5	36	8	38
15	5	12	5	18	6	20	7.5	24	8	32	10	34
20	6	12	6	17	7.5	19	9	23	12	25	18	30
25	7.5	12	7.5	17	8	19	10	23	12	25	18	30
30	8	11	8	16	10	19	14	22	15	24	22.5	30
40	12	12	13	15	16	19	18	21	22.5	24	25	30
50	15	12	18	15	20	19	22.5	21	24	24	30	30
60	18	12	21	14	22.5	17	26	20	30	22	35	28
75	20	12	23	14	25	15	28	17	33	14	40	19
100	22.5	11	30	14	30	12	35	16	40	15	45	17
125	25	10	36	12	35	12	42	14	45	15	50	17
150	30	10	42	12	40	12	52.5	14	52.5	14	60	17
200	35	10	50	11	50	10	65	13	68	13	90	17
250	40	11	60	10	62.5	10	82	13	87.5	13	100	17
300	45	11	68	10	75	12	100	14	100	13	120	17
350	50	12	75	8	90	12	120	13	120	13	135	15
400	75	10	80	8	100	12	130	13	140	13	150	15
450	80	8	90	8	120	10	140	12	160	14	160	15
500	100	8	120	9	150	12	160	12	180	13	180	15

Applies to three-phase, 60Hz motors when switched with capacitors as a single unit.

Another method of selecting the proper capacitor employs the use of only a selection chart shown in Table 2 or 3. These tables take other variables such as motor RPM into consideration in making recommendations for capacitor applications. They are convenient because they only require that the user know the horsepower and RPM of the motor. Both tables estimate the percentage reduction in full load current drawn by the motor as a result of the capacitor's installation.

WARNING!

NEVER OVERSIZE CAPACITORS OR EXCEED 1.0 POWER FACTOR OR RESULTING PROBLEMS WITH THE MOTOR CAN OCCUR!!

If calculations or a kvar determination chart indicate a kvar rating not found in a pricing and selection chart, always refer to the next lower kvar rating!

EXAMPLE: A manufacturer needs to determine the proper capacitors required for a 1200 RPM, 75HP T-Frame NEMA class B motor.

1. First find 75 in the horsepower column of the chart.
2. Locate the 1200 RPM capacitor rating (kvar) column. Note the figure of 25 kvar.
3. Now refer to the appropriate pricing and selection chart Table 1, page 6.11. The appropriate kvar rating is 25 kvar. Depending on the desired enclosure, the price and catalog number can then be easily determined.

NOTE

Using the above charts for selecting capacitors will correct power to approximately .95.

TABLE 3: Suggested Maximum Capacitor Ratings for U-Frame NEMA Class B Motors

H.P. Rating	NEMA Motor Design A or B Normal Starting Torque Normal Running Current											
	3600 RPM		1800 RPM		1200 RPM		900 RPM		720 RPM		600 RPM	
	kvar	%AR	kvar	%AR	kvar	%AR	kvar	%AR	kvar	%AR	kvar	%AR
3	1.5	14	1.5	15	1.5	20	2	27	2.5	35	3.5	41
5	2	12	2	13	2	17	3	25	4	32	4.5	37
7.5	2.5	11	2.5	13	2	15	4	22	5.5	30	6	34
10	3	10	3	11	3.5	14	5	21	6.5	27	7.5	31
15	4	9	4	10	5	13	6.5	18	8	23	9.5	27
20	5	9	5	10	5	11	7.5	18	10	20	10	25
25	5	6	5	8	7.5	11	7.5	13	10	20	10	21
30	5	5	5	8	7.5	11	10	15	15	22	15	25
40	7.5	8	10	8	10	10	15	16	15	18	15	20
50	10	7	10	8	10	9	15	12	20	15	25	22
60	10	6	10	8	15	10	15	11	20	15	25	20
75	15	7	15	8	15	9	20	11	30	15	40	20
100	20	8	20	8	25	9	30	11	40	14	45	18
125	20	6	25	7	30	9	30	10	45	14	50	17
150	30	6	30	7	35	9	40	10	50	17	60	17
200	40	6	40	7	45	8	55	11	60	12	75	17
250	45	5	45	6	60	9	70	10	75	12	100	17
300	50	5	50	6	75	9	75	9	80	12	105	17

Applies to three-phase, 60Hz motors when switched with capacitors as a single unit.

Sizing capacitors at the motor load

Using charts

Power factor correction chart

Original power factor in percent	DESIRED CORRECTED POWER FACTOR IN PER CENT																				
	80	81	82	83	84	85	86	87	88	89	90	91	92	93	94	95	96	97	98	99	100
50	0.982	1.008	1.034	1.060	1.086	1.112	1.139	1.165	1.192	1.220	1.248	1.276	1.306	1.337	1.369	1.403	1.442	1.481	1.529	1.590	1.732
51	.937	.962	.989	1.015	1.041	1.067	1.094	1.120	1.147	1.175	1.203	1.231	1.261	1.292	1.324	1.358	1.395	1.436	1.484	1.544	1.687
52	.893	.919	.945	.971	.997	1.023	1.050	1.076	1.103	1.131	1.159	1.187	1.217	1.248	1.280	1.314	1.351	1.392	1.440	1.500	1.643
53	.850	.876	.902	.928	.954	.980	1.007	1.033	1.060	1.088	1.116	1.144	1.174	1.205	1.237	1.271	1.308	1.349	1.397	1.457	1.600
54	.809	.835	.861	.887	.913	.939	.966	.992	1.019	1.047	1.075	1.103	1.133	1.164	1.196	1.230	1.267	1.308	1.356	1.416	1.669
55	.769	.795	.821	.847	.873	.899	.926	.952	.979	1.007	1.035	1.063	1.090	1.124	1.156	1.190	1.228	1.268	1.316	1.377	1.519
56	.730	.756	.782	.808	.834	.860	.887	.913	.940	.968	.996	1.024	1.051	1.085	1.117	1.151	1.189	1.229	1.277	1.338	1.480
57	.692	.718	.744	.770	.796	.822	.849	.875	.902	.930	.958	.986	1.013	1.047	1.079	1.113	1.151	1.191	1.239	1.300	1.442
58	.655	.681	.707	.733	.759	.785	.812	.838	.865	.893	.921	.949	.976	1.010	1.042	1.076	1.114	1.154	1.202	1.263	1.405
59	.618	.644	.670	.696	.722	.748	.775	.801	.828	.856	.884	.912	.939	.973	1.005	1.039	1.077	1.117	1.165	1.226	1.368
60	.584	.610	.636	.662	.688	.714	.741	.767	.794	.822	.850	.878	.907	.939	.971	1.005	1.043	1.083	1.131	1.192	1.334
61	.549	.575	.601	.627	.653	.679	.706	.732	.759	.787	.815	.843	.870	.907	.936	.970	1.008	1.048	1.096	1.157	1.299
62	.515	.541	.567	.593	.619	.645	.672	.698	.725	.753	.781	.809	.836	.870	.902	.936	.974	1.014	1.062	1.123	1.265
63	.483	.509	.535	.561	.587	.613	.640	.666	.693	.721	.749	.777	.804	.838	.870	.904	.942	.982	1.030	1.091	1.233
64	.450	.476	.502	.528	.554	.580	.607	.633	.660	.688	.716	.744	.771	.805	.837	.871	.909	.949	.997	1.058	1.200
65	.419	.445	.471	.497	.523	.549	.576	.602	.629	.657	.685	.713	.740	.774	.806	.840	.878	.918	.966	1.027	1.169
66	.388	.414	.440	.466	.492	.518	.545	.571	.598	.626	.654	.682	.709	.743	.775	.809	.847	.887	.935	.996	1.138
67	.358	.384	.410	.436	.462	.488	.515	.541	.568	.596	.624	.652	.679	.713	.745	.779	.817	.857	.905	.966	1.108
68	.329	.355	.381	.407	.433	.459	.486	.512	.539	.567	.595	.623	.650	.684	.716	.750	.788	.828	.876	.937	1.079
69	.299	.325	.351	.377	.403	.429	.456	.482	.509	.537	.565	.593	.620	.654	.686	.720	.758	.798	.840	.901	1.043
70	.270	.296	.322	.348	.374	.400	.427	.453	.480	.508	.536	.564	.591	.625	.657	.691	.729	.769	.811	.872	1.014
71	.242	.268	.294	.320	.346	.372	.399	.425	.452	.480	.508	.536	.563	.597	.629	.663	.701	.741	.783	.844	.986
72	.213	.239	.265	.291	.317	.343	.370	.396	.423	.451	.479	.507	.535	.568	.600	.634	.672	.712	.754	.815	.957
73	.186	.212	.238	.264	.290	.316	.343	.369	.396	.424	.452	.480	.507	.541	.573	.607	.645	.685	.727	.788	.930
74	.159	.185	.211	.237	.263	.289	.316	.342	.369	.397	.425	.453	.480	.514	.546	.580	.616	.658	.700	.761	.903
75	.132	.158	.184	.210	.236	.262	.289	.315	.342	.370	.398	.426	.453	.487	.519	.553	.591	.631	.673	.734	.876
76	.105	.131	.157	.183	.209	.235	.262	.288	.315	.343	.371	.399	.426	.460	.492	.526	.564	.604	.652	.713	.855
77	.079	.105	.131	.157	.183	.209	.236	.262	.289	.317	.345	.373	.400	.434	.466	.500	.538	.578	.620	.681	.823
78	.053	.079	.105	.131	.157	.183	.210	.236	.263	.291	.319	.347	.374	.408	.440	.474	.512	.552	.594	.655	.797
79	.026	.052	.078	.104	.130	.156	.183	.209	.236	.264	.292	.320	.347	.381	.413	.447	.485	.525	.567	.628	.770
80	.000	.026	.052	.078	.104	.130	.157	.183	.210	.238	.266	.294	.321	.355	.387	.421	.459	.499	.541	.602	.744
81	-	.000	.026	.052	.078	.104	.131	.157	.184	.212	.240	.268	.295	.329	.361	.395	.433	.473	.515	.582	.724
82	-	-	.000	.026	.052	.078	.105	.131	.158	.186	.214	.242	.269	.303	.335	.369	.407	.447	.489	.556	.698
83	-	-	-	.000	.026	.052	.079	.105	.132	.160	.188	.216	.243	.277	.309	.343	.381	.421	.463	.530	.672
84	-	-	-	-	.000	.026	.053	.079	.106	.134	.162	.190	.217	.251	.283	.317	.355	.395	.437	.504	.646
85	-	-	-	-	-	.000	.027	.053	.080	.108	.136	.164	.191	.225	.257	.291	.329	.369	.411	.478	.620
86	-	-	-	-	-	-	.000	.026	.053	.081	.109	.137	.167	.198	.230	.265	.301	.343	.390	.451	.593
87	-	-	-	-	-	-	-	.000	.027	.055	.082	.111	.141	.172	.204	.238	.275	.317	.364	.425	.567
88	-	-	-	-	-	-	-	-	.000	.028	.056	.084	.114	.145	.177	.211	.248	.290	.337	.398	.540
89	-	-	-	-	-	-	-	-	-	.000	.028	.056	.086	.117	.149	.183	.220	.262	.309	.370	.512
90	-	-	-	-	-	-	-	-	-	-	.000	.028	.058	.089	.121	.155	.192	.234	.281	.342	.484
91	-	-	-	-	-	-	-	-	-	-	-	.000	.030	.061	.093	.127	.164	.206	.253	.314	.456
92	-	-	-	-	-	-	-	-	-	-	-	-	.000	.031	.063	.097	.134	.176	.223	.284	.426
93	-	-	-	-	-	-	-	-	-	-	-	-	-	.000	.032	.066	.103	.145	.192	.253	.395
94	-	-	-	-	-	-	-	-	-	-	-	-	-	-	.000	.034	.071	.113	.160	.221	.363
95	-	-	-	-	-	-	-	-	-	-	-	-	-	-	-	.000	.037	.079	.126	.187	.329
96	-	-	-	-	-	-	-	-	-	-	-	-	-	-	-	-	.000	.042	.089	.150	.292
97	-	-	-	-	-	-	-	-	-	-	-	-	-	-	-	-	-	.000	.047	.108	.251
98	-	-	-	-	-	-	-	-	-	-	-	-	-	-	-	-	-	-	.000	.061	.203
99	-	-	-	-	-	-	-	-	-	-	-	-	-	-	-	-	-	-	-	.000	.142

Sizing Capacitors for Improving System Power Factor

Sizing and selecting capacitors for system power factor correction is calculated using a Power Factor Correction Chart. Before this chart can be used, however, the total kW requirement needs to be known for the ENTIRE system in addition to the PRESENT and DESIRED power factors.

EXAMPLE: A plant has a present power factor level of .75; a load draws 806 amps at 480V; average power consumption of 500kW; and a desired power factor level of .90. Compute the necessary capacitance required and select the proper automatic and fixed bank unit.

1. First, look at the left hand column of the Power Factor Correction chart entitled "Original Power Factor". Find your current power factor level of .75.
2. Second, follow the column of figures to the right of the .75 figure until you come to the column entitled ".90" (your desired power factor level).

3. The number in that row is .398. Now multiply this figure by the total plant kW of 500:

$$.398 \times 500\text{kW} = 199 \text{ kvar}$$

4. The resulting total of 199 represents the amount of capacitive power (kvar) required to bring the power factor to the desired level of .90.
5. Referring to the sample selection charts (See Table 4 or Table 5, next page), select the appropriate kvar rating.

NOTE: When selecting automatic bank units, select the closest kvar rating to the amount of kvar desired based on present and future applications. If the desired rating is not listed, the next higher kvar rating should be selected. When selecting fixed bank units, however, select the kvar rating WITHOUT GOING OVER (See Warning, page 6.12) the desired capacitance level.

In this example for the automatic capacitor bank, 200 kvar is the closest to the desired 199 kvar. For the fixed capacitor bank, 180 kvar should be selected without going over the desired kvar of 199.

Sizing capacitors at the motor load Using charts

What if Present Power Factor Cannot Be Determined Because kVA is Unknown?

1. First, find the apparent power (kVA). kVA demand on a 3-phase system is equal to:

$$\text{kVA} = \text{VOLTS} \times \text{AMPS} \times \sqrt{3} \div 1000$$

2. The voltage and amperage of the distribution system will be known. Again, using the above example, we know that the distribution system is 480 volts and draws 806 amps. Therefore:

$$480 \text{ VOLTS} \times 806 \text{ AMPS} \times \sqrt{3} \div 1000 = 670 \text{ kVA}$$

3. Now power factor can be solved for:

$$500 \text{ kW} / 670 \text{ kVA} = .746 \text{ pf}$$

4. With the power factor now known, the Power Factor Improvement chart can be used as before.

How is the Power Factor Correction Chart Used if Existing Power Factor Level is Unknown?

1. First, power factor has to be calculated. Power factor is equal to active power (kW) divided by apparent power (kVA). kW will be known because it is the total amount of power consumed over a given period of time and is the amount shown on a utility bill. Therefore:

$$\text{pf} = \text{kW} / \text{kVA}$$

2. Using the above example, 500kW divided by 670kVA equals a present power factor (pf) of .746.

$$500 \text{ kW} / 670 \text{ kVA} = .746 \text{ pf}$$

3. When DETERMINING power factor, always round off to the next higher rating. Therefore, the .746 power factor figure is rounded off to .75.

NOTE: Don't confuse rounding UP a power factor figure that is manually calculated with the warning on page 46 that tells you to round DOWN when using a catalog selection chart!

4. Now that present power factor is known, the above problem can be solved as before.

FINAL EXAMPLE: A manufacturer has a 480 volt, 3-phase metered demand of 460kW. An ammeter on the system shows total current draw of 770 amps. Existing power factor and apparent power (kVA) are unknown. What is the existing system power factor and how much capacitance is required to correct to .92?

1. First, solve for kVA.

$$480 \text{ VOLTS} \times 770 \text{ AMPS} \times \sqrt{3} \div 1000 = 640 \text{ kVA}$$

2. Next, solve for Power Factor.

$$460 \text{ kW} / 640 \text{ kVA} = .72 \text{ POWER FACTOR}$$

3. To correct the power factor from .72 to .92 refer to the Power Factor

TABLE 4 - Fixed Capacitor Banks

110	2/55	F246G110
120	2/60	F246G120
130	1/40, 2/45	F246G130
150	3/50	F246G150
160	2/80	F246G160
180	3/60	F246G180
200	4/50	F246G200
200	4/50	F246G200

TABLE 5 - Automatic Capacitor Banks

125	AA4G150B6A	AA4D125B
150	AA4G150B6A	AA4D150B6A
175	AA4G175B7A	AA4D175B7A
200	AA4G200B8A	AA4D200B8A
225	AA4G225B9A	AA4D225B9A
250	AA4G250B10A	AA4D250B10A
300	AA4G300B12A	AA4D300B12A

Correction Chart on page 47. A factor of .534 will be determined.

4. The final step is to multiply the 460kW figure by the correction factor of .534.

$$460 \text{ kW} \times .534 = 245 \text{ kvar}$$

This system would require the installation of 245 kvar of capacitance to improve the power factor to .92. Refer to the appropriate automatic or fixed bank catalog pages, select the proper voltage and phase, then identify the proper catalog number.

Typical recommended ratings of cables & protected devices

**Low Voltage
Network Quality**

Typical recommended ratings of cables and protected devices

3- Phase Capacitor kVar	Rated Current Per Phase (amps)	Minimum Copper Cable Size for 75oC Insulation	Recommended fuse amps Type Class RK5 (Time Delay)	Recommended Disconnect Switch Amps	Recommended MCCB Trip Amps
240 Volt					
2.5	6	#14	10	30	15
3.5	8.4	#14	15	30	15
5	12	#14	20	30	20
7.5	18	#12	30	30	30
10	24	#10	40	60	40
15	36	#6	60	60	60
20	48	#4	80	100	80
25	60	#4	100	100	90
30	72	#2	125	200	110
40	96	#1	175	200	150
50	120	1/0	200	200	200
60	144	2/0	250	400	225
75	180	250 kcmil	300	400	300
100	241	400 kcmil	400	400	400
125	301	(2) - 4/0	500	600	500
150	361	(2) - 250 kcmil	600	600	600
200	481	(2) - 400 kcmil	800	800	750
250	601	(3) - 300 kcmil	1000	1000	900
300	722	(3) - 400 kcmil	1200	1200	1100
480 Volt					
1.5	1.8	#14	3	30	15
2	1.8	#14	3	30	15
2.5	3	#14	6	30	15
3	3.6	#14	6	30	15
3.5	4.2	#14	10	30	15
4	4.8	#14	10	30	15
5	6	#14	10	30	15
6	7.2	#14	15	30	15
6.5	7.8	#14	15	30	15
7.5	9	#14	15	30	15
10	12	#14	20	30	20
15	18	#12	30	30	30
20	24	#10	40	60	40
25	30	#8	50	60	50
30	36	#6	60	60	60
35	42	#6	70	100	70
40	48	#4	80	100	80
45	54	#4	90	100	90
50	60	#4	100	100	90
60	72	#2	125	200	110
70	84	#1	150	200	150
75	90	#1	150	200	150
80	96	#1	175	200	150
90	108	1/0	200	200	175
100	120	2/0	200	200	200
150	180	250 kcmil	300	400	300
200	241	400 kcmil	400	400	400
250	301	(2) - 4/0	500	600	500
300	361	(2) - 250 kcmil	600	600	600
350	421	(2) - 300 kcmil	700	800	650
400	481	(2) - 400 kcmil	800	800	750
500	601	(3) - 300 kcmil	1000	1000	902

Typical recommended ratings of cables & protected devices

Typical recommended ratings of cables and protected devices

3-Phase Capacitor kvar	Rated Current Per Phase (amps)	Minimum Copper Cable Size for 75oC Insulation	Recommended fuse amps Type RK5 (Time Delay)	Recommended Disc Switch Amps	Recommended MCCB Trip Amps
600 Volt					
2	2	#14	3	30	15
3	3	#14	6	30	15
4	4	#14	6	30	15
5	5	#14	10	30	15
7.5	7	#14	15	30	15
10	10	#14	20	30	15
15	14	#14	25	30	25
20	19	#10	35	60	30
25	24	#10	40	60	40
30	29	#8	50	60	50
35	34	#8	60	60	60
40	38	#6	70	100	60
45	43	#6	80	100	70
50	48	#4	80	100	80
60	58	#4	100	100	90
70	67	#2	125	200	110
80	77	#2	150	200	125
90	87	#1	150	200	150
100	96	#0	175	200	150
150	144	3/0	250	400	225
200	192	300 kcmil	350	400	300
250	241	400 kcmil	400	400	400
300	289	(2) - 3/0	500	600	450
350	337	(2) - 4/0	600	600	550
400	385	(2) - 300 kcmil	650	800	600
500	481	(2) - 400 kcmil	800	800	750

NOTE: Cable sizes are derived from Article 310, Table 310-16 of 2002 **NEC**®

The above table gives recommended ratings of cables, disconnect switches, and/or molded case circuit breakers for use with capacitor loads. For requirements not covered in the table, the following application guidelines may be used for capacitor switching duty:

- Power Cable Sizing 135% of Capacitor Current
- Disconnect Switch 165% of Capacitor Current
- Molded Case Circuit Breaker 135% of Capacitor Current

Note: For specific applications, refer to the NEC®.

Extract from NEC® Separate overcurrent protection

Extract from 2002 NEC® Code Requirements

460-8. Conductors.

(A) Ampacity. The ampacity of capacitor circuit conductors shall not be less than 135 percent of the rated current of the capacitor. The ampacity of conductors that connect a capacitor to the terminals of a motor or to motor circuit conductors shall not be less than one third the ampacity of the motor circuit conductors and in no case less than 135 percent of the rated current of the capacitor.

(B) Overcurrent Protection. An overcurrent device shall be provided in each ungrounded conductor for each capacitor bank. The rating or setting of the overcurrent device shall be as low as practicable.

Exception: A separate overcurrent device shall not be required for a capacitor connected on the load side of a motor overload protective device.

(C) Disconnecting Means. A disconnecting means shall be provided in each ungrounded conductor for each capacitor bank and shall meet the following requirements.

- (1) The disconnecting means shall open all ungrounded conductors simultaneously.
- (2) The disconnecting means shall be permitted to disconnect the capacitor from the line as a regular operating procedure.
- (3) The rating of the disconnecting means shall not be less than 135 percent of the rated current of the capacitor.

Exception: A separate disconnecting means shall not be required where a capacitor is connected on the load side of a motor controller.

460-9. Rating or Setting of Motor Overload Device. Where a motor installation includes a capacitor connected on the load side of the motor overload device, the rating or setting of the motor overload device shall be based on the improved power factor of the motor circuit.

The effect of the capacitor shall be disregarded in determining the motor circuit conductor rating in accordance with Section 430-22.

NOTE: National Electric Code® and NEC® are registered trademarks of the National Fire Protection Association, Inc., Quincy, MA 02269

Reprinted with permission from NFPA 70-2002, The National Electrical Code®, 2002, National Fire Protection Association, Quincy, MA 02269. This reprinted material is not the complete and official position of the NFPA, on the referenced subject which is represented only by the standard in its entirety.

Separate overcurrent protection

A separate overcurrent device is not necessary when an ABB capacitor is electrically connected on the load side of the motor starter fused safety switch or breaker. Personnel and facility short circuit protection is provided within the capacitor by ABB's patented Sequential Protection System. Short circuit protection between the main feed and the capacitor is provided by the motor starter fused safety switch or breaker. A disconnect switch can be provided when the capacitor is connected as illustrated in Option C (See Fig. 12). When the capacitor is connected as shown in Option C, the capacitor remains energized when the motor is off. The optional disconnect switch provides a means to disconnect the capacitor when the motor is not in operation.

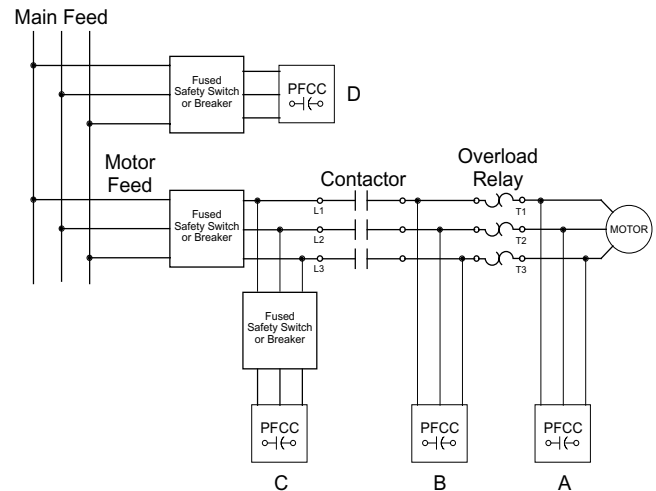

Fig. 12

