

# PROTECTION UNIT PR223EF



---

# INDEX

1 IDENTIFICATION .....	3
<b>1.1 Standard .....</b>	<b>3</b>
2 SAFETY NOTES .....	4
<b>2.1 Notes for dielectric strength tests .....</b>	<b>4</b>
3 ABBREVIATIONS AND MISCELLANEOUS NOTES .....	5
<b>3.1 Abbreviations .....</b>	<b>5</b>
<b>3.2 Miscellaneous notes .....</b>	<b>5</b>
4 SPECIFICATIONS .....	6
<b>4.1 General .....</b>	<b>6</b>
<b>4.2 Electrical characteristics .....</b>	<b>6</b>
4.2.1 Self-supply .....	6
4.2.2 Auxiliary power supply .....	6
<b>4.3 Environmental characteristics .....</b>	<b>7</b>
<b>4.4 Inputs/Outputs .....</b>	<b>7</b>
4.4.1 Output contacts .....	7
4.4.2 System bus .....	7
4.4.3 Interlock Bus (IL) .....	7
<b>4.5 Protection functions .....</b>	<b>7</b>
4.5.1 Calculating the RMS and Peak .....	8
4.5.2 “L” protection .....	8
4.5.3 “S” protection .....	8
4.5.4 “T” protection .....	9
4.5.5 “G” protection .....	9
4.5.6 "EF" protection .....	9
4.5.7 “Inst” protection .....	10
4.5.8 Back-up protection .....	10
4.5.9 Trip reset .....	10
4.5.10 Programmable signalling contact S51/P1 .....	10
<b>4.6 Zone selectivity .....</b>	<b>11</b>
4.6.1 Interlock (IL) .....	11
4.6.2 Type of connection .....	12
4.6.3 SOS Function .....	14
<b>4.7 Measuring functions .....</b>	<b>15</b>
4.7.1 Current measurements .....	15
4.7.2 Voltage measurements .....	15
4.7.3 Frequency measurements .....	15
<b>4.8 INFORMATION .....</b>	<b>15</b>
4.8.1 Trip history .....	16
<b>4.9 Communication .....</b>	<b>17</b>
<b>4.10 Test .....</b>	<b>17</b>
4.10.1 Self-diagnosis .....	17
4.10.2 Test unit .....	17
4.10.3 Trip Test Unit .....	17
4.10.4 Electronic Trip Test .....	17

---

4.10.5 Autotest .....	17
5 USER INTERFACE .....	18
<b>5.1 Front plate</b> .....	<b>18</b>
<b>5.2 Meanings of alarm and status leds</b> .....	<b>18</b>
<b>5.3 REM-LOC push button</b> .....	<b>19</b>
<b>5.4 Default settings</b> .....	<b>20</b>
6 SETTING UP .....	21
<b>6.1 Connections</b> .....	<b>21</b>
<b>6.2 Test</b> .....	<b>21</b>
<b>6.3 Initial settings</b> .....	<b>21</b>
7 OPERATING INSTRUCTIONS / OPERATION IN SERVICE .....	22
<b>7.1 Programming</b> .....	<b>22</b>
8 TROUBLESHOOTING .....	23
9 WARNING .....	24
<b>9.1 In the event of a fault</b> .....	<b>24</b>
10 ACCESSORIES .....	25
<b>10.1 PR010/T test unit</b> .....	<b>25</b>
<b>10.2 TT1 test unit</b> .....	<b>25</b>
<b>10.3 BT030 connection unit</b> .....	<b>25</b>
<b>10.4 Display unit FDU</b> .....	<b>25</b>
<b>10.5 HMI030 display unit</b> .....	<b>25</b>
<b>10.6 Voltage Module VM210</b> .....	<b>25</b>
<b>10.7 PR021/K signalling unit</b> .....	<b>26</b>
<b>10.8 SW210 switch module.</b> .....	<b>26</b>
11 APPENDIX .....	27
<b>11.1 Trip curves</b> .....	<b>27</b>
<b>11.2 Wiring diagram</b> .....	<b>30</b>

---

# 1 IDENTIFICATION

The PR223EF unit is available in combination with the following circuit-breakers:

- Tmax T4
- Tmax T5
- Tmax T6

---

## 1.1. Standard

The PR223EF has been designed to work in accordance with the international standard:  
IEC60947-2 Low voltage apparatus. Circuit-breakers.

---

## 2 SAFETY NOTES

**WARNING:** This symbol identifies information on practices, actions and circumstances which might result in injury or harm to personnel, damage to the unit or economic loss.

Read this manual carefully and completely.

This device should only be used by qualified competent personnel.

If there are any doubts about safe use the unit should be placed out of service protecting it against unintentional use.

Safe use must be assumed to be impossible if:

1. There is visible damage to the unit.
2. The unit is not operating (for example in the test).
3. The unit has suffered damage during transport.

---

### 2.1. Notes for dielectric strength tests

**WARNING:** Dielectric strength tests on PR223EF inputs and outputs are not permitted.

---

## 3 ABBREVIATIONS AND MISCELLANEOUS NOTES

---

### 3.1. Abbreviations

Abbreviation	Meaning
CB	Circuit Breaker (E.g. Emax/Tmax)
Emax	ABB SACE air circuit-breaker series
FDU	Front Display Unit
HMI	Human Machine Interface
HW	Hardware
IL	Interlock connection
In	Rated current of the current transformers (CT) installed in the circuit-breaker
PR021/K	ABB SACE signalling unit
PR010/T	ABB SACE test unit
PR223EF	Protection relay for Tmax CB
Relay	Also known as "Protection unit" or "Protection release" or "Release"
RMS	Effective Value
SdZ	Zone Selectivity
SW	Software
CT	Current Transformer
TC	Trip coil. This is the actuator through which the relay controls opening of the CB
Tmax	ABB SACE moulded case circuit breaker series
Trip	Action opening the CB, generated by PR223EF
TT1	ABB SACE test unit
Vaux	Auxiliary power supply
VM210	ABB Voltage Module
W1	System Bus
W2	Uplink communication bus for interlock
W3	Downlink communication bus for interlock

---

### 3.2. Miscellaneous notes

Use screened 2-core braided 2-wire cable for RS485 (not supplied by ABB SACE).  
E.g. Belden 3105A

# 4 SPECIFICATIONS

## 4.1. General

The PR223EF unit is a high performance protection unit with Protection, Measurement, Self-diagnosis, Signalling, Test, Circuit-breaker monitoring, Communication and Memory functions for Low Voltage circuit-breakers of the ABB SACE 3-pole and 4-pole moulded-case type Tmax series.

The protections available are:

Symbol	Protection against ...
L	overload with inverse long time delay
S	short-circuit with adjustable delay
I	instantaneous short-circuit
G	earth fault with adjustable delay
EF	Ultrafast instantaneous short-circuit

**Table 1.** Protections available

The PR223EF is available on both three-pole, three-pole with external neutral and four-pole CB.

The reference current for PR223EF is  $I_n$  (rated current of the CT mounted on the CB) and not  $I_u$  (the uninterrupted rated current of the CB itself). Example: The T4L-320 CB with 160 A CT has an  $I_u$  of 320 A and an  $I_n$  of 160 A.

The unit opens the circuit-breaker in which it is installed by means of the TC, which acts directly on the device's mechanical lever system.

The CT provides both energy to power the relay and the signal to calculate the current in the CB busbars.

For more information on self- and auxiliary supply see section Electrical characteristics.

The VM210 module (see section 10.6 Voltage Module VM210) provides the signals used for further measurement functions.

The unit is constructed using microprocessor digital technology. There are 8 single colour leds on the front of the release which provide status and alarm indications.

The parameters for the protections and in general the unit's operating modes can be fully programmed by the user using external devices. (see section 10.1 PR010/T test unit) (see section 10.3 BT030 connection unit)

## 4.2. Electrical characteristics

Rated operating frequency	50/60 Hz $\pm 10\%$
Peak factor	14@2In

### 4.2.1. Self-supply

The L, S, I, G protection functions (see Table 1. Protections available) are active even without external auxiliary power supply. The self-supply is ensured by the CT installed in the CB.

Minimum busbar current for tripping the release:

- 0.20 x  $I_n$  with single phase current
- 0.10 x  $I_n$  with two phase current
- 0.10 x  $I_n$  with three-phase current

**Note:** the relay has full control over protection functions under any load conditions. All possible situations are completely controlled.

### 4.2.2. Auxiliary power supply

The auxiliary power supply ensures that the PR223EF will operate under any conditions, even with the CB open or with less current flowing than the values mentioned in the preceding section.

ABB SACE		PR223EF	1SDH000538R0002	L5055	6/31
----------	---	---------	-----------------	-------	------

The auxiliary power supply also makes it possible to take advantage of the developed functions of the release (EF protection, Modbus communication, interlock and measurement signals).

An unexpected fall or loss of Vaux will not affect the safety of the equipment and persons. The L, S, I, G protection functions are in any event also guaranteed by self-supply alone.

The relay is fully operational after a max of 1s after Vaux has been fed in.

**WARNING:** As a Vaux which is isolated from earth is required "galvanically separated converters" must be used in accordance with standard IEC 60950 (UL 1950) or its equivalents [which ensure a common current or leakage current (see IEC 478/1, CEI 22/3) of not more than 3.5 mA], IEC 60364-41 and CEI 64-8.

Characteristics	PR223EF
Power supply voltage	24 Vdc $\pm$ 20%
Maximum ripple	5%
Inrush Current @ 24 V	~4 A for 0.5 ms
Start-up Current @ 24 V	~0.5 A for 50 ms
Rated Current @ 24 V	~80 mA
Rated Power @ 24 V	~2 W

**Table 2.** Auxiliary power supply characteristics

### 4.3. Environmental characteristics

Operating environmental temperature	-25 °C ... +70 °C
Storage temperature	-40 °C ... +70 °C
Relative humidity	0% ... 98% with condensation

### 4.4. Inputs/Outputs

#### 4.4.1. Output contacts

S51/P1:	Relay output for programmable signalling (see PR223EF Modbus™ System Interface doc. 1SDH000566R0002) Monostable contact, also active when self-powered. Contact type: photoMos    Vmax: 48 Vdc/ 30 Vac Rmax: 35 Ohm Pmax: 200 mW (resistive load)
---------	--

#### 4.4.2. System bus

W1:	RS485 system bus, Baud rate 19200, Modbus™ RTU protocol (see PR223EF Modbus™ System Interface doc. 1SDH000566R0002)
-----	---

#### 4.4.3. Interlock Bus (IL)

W2:	Communication bus (uplink) for interlock to upstream circuit-breaker.
W3:	Communication bus (downlink) for interlock from downstream circuit-breaker.

### 4.5. Protection functions

The PR223EF protection unit carries out 5 independent protection functions. In particular:

1. Inverse time protection against overload "L";
2. Protection against short-circuit with adjustable delay "S";
3. Protection against instantaneous short-circuit "I";
4. Protection against earth fault with adjustable delay "G";
5. Enhanced "EF" short-circuit protection "EF";

The following relationship applies for constant time protections (S and I):

$t = \text{constant}$

The relationship between trip time and fault current provided by the formula:

$$t = \frac{k}{I^2/I_s^2}$$

applies to inverse time protections (L, S and G).

This formula defines a constant energy curve, in which:

t	= trip time
k	= parameter defining the trip curve
I	= fault current
I <sub>s</sub>	= trip threshold selected by the user

With the PR223EF unit the neutral pole current signal can be processed using two different relationships relating to the value of the phases (Off – 50% – 100%).

All protections also have the following common functional characteristics:

- Exclusively electronic programming (no dipswitch on the front)
- The information and the status of each protection can be seen in various ways via the front led (L protection) or other devices (see section 4.8. INFORMATION).

#### 4.5.1. Calculating the RMS and Peak

The "L, S and G" protection functions measure current on the basis of the true effective value (RMS).

The L protection uses the RMS current up to a fault current of 6 I<sub>n</sub>; for larger currents it uses the effective value obtained from the peak current.

The S protection uses the RMS current up to a fault current of 2 I<sub>n</sub>; for larger currents it uses the effective value obtained from the peak current.

#### 4.5.2. "L" protection

The "L" protection is the only one that can't be disabled as it provides self-protection against overload for the release itself. It is active both with an auxiliary power supply and when self-powered.

The trip of protection "L" is defined by the following parameters:

Name	Description	Range	Step
I1	Threshold	0.18...1.0 I <sub>n</sub> <sup>1</sup>	0.01 I <sub>n</sub>
t1	Trip time @ 6 I1	0.5...18 <sup>2</sup> s	0.5 s

1. for 0.18 ≤ I1 ≤ 0.39 protection N at 100%I<sub>n</sub>
2. for CB T4/320A, T5/630A and T6/1000A t1 max is 10,5 s.

**Table 3.** L protection - System parameters

The PR223EF release has an L pre-alarm function (LED indication on the front). The pre-alarm, which can be disabled by the user, is fixed at 0.9 x I1

#### 4.5.3. "S" protection

The protection, which can be disabled, can be inverse time or constant time (see section 4.5. Protection functions).

##### 4.5.3.1 Inverse time curve

The protection curve is established by the following parameters:

Name	Description	Range	Step
I2	Threshold	0.6...10 I <sub>n</sub> <sup>1</sup>	0.1 I <sub>n</sub>
t2	Trip time @ 8I <sub>n</sub>	0.05...0.5 s	0.01 s

1. for CB T4/320A, T5/630A and T6/1000A I2 max is 9,5I<sub>n</sub>.

**Table 4.** Inverse time S protection - System parameters

#### 4.5.3.2 Constant time curve

The protection curve is established by the following parameters:

Name	Description	Range	Step
I2	Threshold	0.6...10 In <sup>1</sup>	0.1 In
t2	Trip time	0.05...0.5 s	0.01 s

1. for CB T4/320A, T5/630A and T6/1000A I2 max is 9,5In

**Table 5.** Constant time S protection - System parameters

#### 4.5.4. "I" protection

The protection, which can be disabled, is provided with an intentional delay of zero.

The protection curve is established by the following parameters:

Name	Description	Min	Step
I3	Threshold	1.5...12 <sup>1</sup> In	0.1 In

1. for CB T4/320A, T5/630A and T6/1000A I3 max is 9,5In, for CB T6/800A I3 max is 10,5In.

**Table 6.** I protection - System parameters

#### 4.5.5. "G" protection

The protection, which can be disabled, is inverse time.

Protection G is inhibited if current I is greater than a specific level depending upon the setting for value I4; (see section 11.1. Trip curves).

The protection curve is established by the following parameters

Name	Description	Range	Step
I4	Threshold	0.2...1.0In	0.1 In
t4	Minimum trip time	0.1...0.8 s	0.01 s

**Table 7.** G protection - System parameters

#### 4.5.6. "EF" protection

The EF protection, which can be disabled, is designed to detect the occurrence of a short circuit during the first few instants to trip before the current reaches excessively high values. This protection function makes it possible to identify a fault extremely quickly.

The EF and I protections are mutually exclusive. If the EF protection is enabled and active protection I is inactive.

Through parameter *Trip Delayed*, it is possible to delay the trip of protection EF.

With this parameter active selectivity is obtained with the protection devices downstream, closer to the load, which do not have a PR223EF release (e.g. CB Tmax T1, T2 and modular circuit-breakers, etc.). This parameter must be set for the last device in the chain as shown in the following picture.

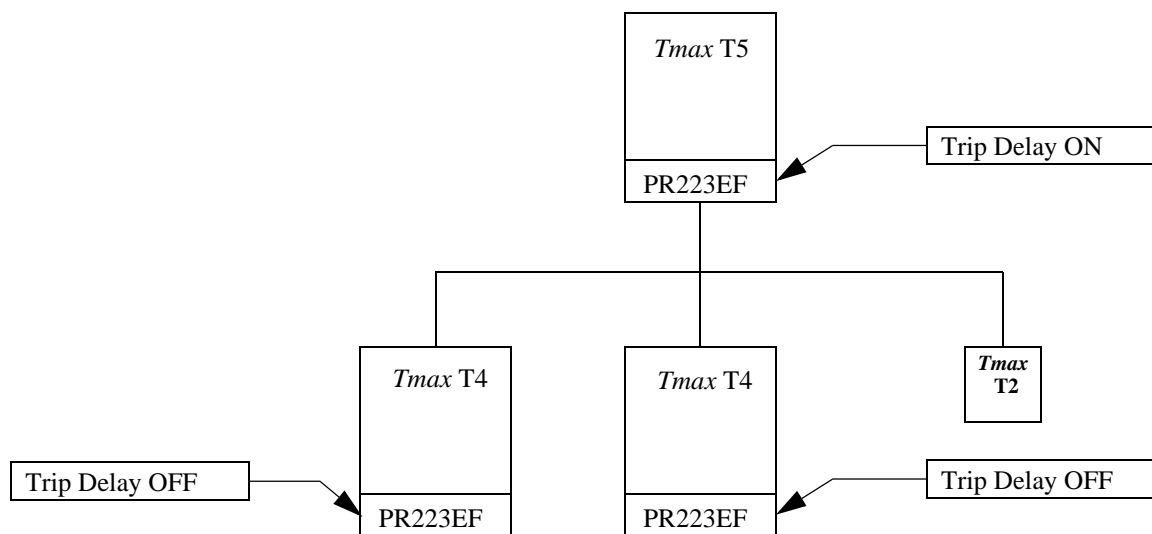

Figure 1. Trip Delay connection diagram

#### 4.5.7. “linst” protection

This is a protection used to protect the circuit-breaker from very high short-circuit currents. It is active under the following conditions:

- Self-supply (Vaux absent)
- EF disabled by user setting
- EF unavailable due to internal fault

#### 4.5.8. Back-up protection

In order to further increase the safety of the system, release PR223EF implements a back-up mechanism to deal with any problems in opening the CB through TC.

When a protection reaches the end of the time delay, it sends an opening command to TC.

After sending the command, the release checks that current is flowing in the circuit-breaker. If this is the case a further opening command is sent through the MOE-E motor control (if present) and the command to TC is repeated. The procedure is repeated every 100 ms (except for the command to MOE-E which is only sent the first time) until the relay continues to read the current passing through the CB.

#### 4.5.9. Trip reset

After a trip, the CB status indication on the system bus has to be reset.

The possible modes are:

- Remote control (Trip reset/CB reset) via a system bus
- Manual operation (CB reset), or the control lever set to Off

The release is also capable of carrying out the Trip Reset operation in the absence of auxiliary contacts (AUX-E) using current as a basis.

#### 4.5.10. Programmable signalling contact S51/P1

There is a contact S51/P1 in device PR223EF which can be programmed by the user by selecting between numerous events (see PR223EF Modbus™ System Interface doc. 1SDH000566R0002).

A PR10/T palm unit or a supervision program connected to the system bus will have to be used to change this parameter.

This contact can also be used to perform load control functions such as for example disconnecting non-priority loads. This protection can be used to detach individual loads before the overload protection L acts to open the circuit-breaker.

When self-powered operation of the contact is ensured by a current of more than 0.3In

S51/P Configuration	
1	Parameters changed
2	Test unit connected
3	Test unit not connected
4	CB tripped
5	CB closed
6	CB open
7	CB status undefined
8	CB status defined
9	Trip command fail
10	Local operating mode
11	Remote operating mode
12	Any alarm
13	L prealarm
14	L timing
15	S timing
16	G timing
17	EF alarm
18	EF interlocked
19	S interlocked
20	G interlocked
21	IL fault uplink
22	IL fault downlink
23	SOS requested
24	TC error
25	MOE-E overtemperature
26	Frequency Out Of Range
27	Any trip
28	L trip
29	S trip
30	I trip
31	Iinst trip
32	G trip
33	EF trip
34	SOS trip
35	Trip reset
36	Aux On
37	Aux Off
38	MOE-E present
39	MOE-E absent
40	Clock failure
41	S Zone Selectivity
42	G Zone Selectivity

## 4.6. Zone selectivity

The Tmax circuit-breakers with the PR223EF release are provided with zone selectivity functionality (logic).

The zone selectivity functionalities are active when an auxiliary power supply is present.

### 4.6.1. Interlock (IL)

The interlock can be used to implement the zone selectivity concept in the moulded-case circuit-breakers of the Tmax range. With this system, together with the EF protection function, it is possible to obtain a very high level of selectivity in the system.

The Tmax circuit-breakers provided with the PR223EF release are connected together through a serial connection (IL Bus). Selectivity between devices can be obtained through this connection, ensuring that the CB closest to the fault trips in such a way as to cut off power only from the area affected by the fault thus ensuring that the remaining part of the circuit continues to be powered. The interlock function is brought into play for faults detected by the EF, S (with both curves) and G protections.

In order to achieve selectivity, if A is the supply side circuit breaker and B is the load side circuit breaker, the following must be valid:

- $t_2 A \geq t_2 B + 10 \text{ ms}$ .
- $t_4 A \geq t_4 B + 10 \text{ ms}$ .

The interlock is brought into play using a proprietary communication protocol.

The PR223EF releases are capable of constantly and automatically monitoring the continuity of the interlock line IL (MONITOR function).

If the IL Bus is interrupted, the INTERLOCK led lights up.

The maximum cable length at one level for the IL bus, without the end of the line, is 1000 meters with SW 3.xx or later; 200 meters with SW 2.xx or earlier (see Figure 2.).

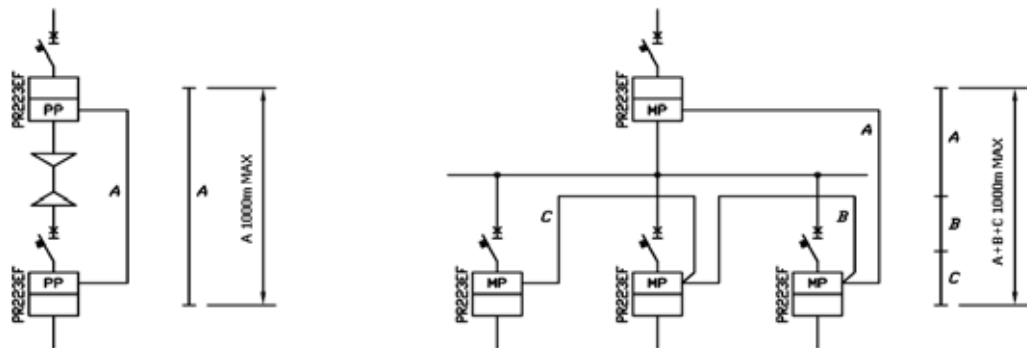

**Figure 2.** Wiring diagram

Use of a cable of the type indicated in section 3.2. Miscellaneous notes.

For other configurations (greater lengths, different type of cable, etc., etc.) proper balancing of the interlock line needs to be evaluated bearing in mind that the signal speed is 100 kbits/s.

For further information consult ABB SACE.

#### 4.6.2. Type of connection

The following active members are defined within the interlock function (IL):

- *CB/Master Relay*: it is the CB/Relay which occupies the hierarchically higher level in the IL connection (upstream towards the power supply)
- *CB/Slave Relay*: it is the CB/Relay which is at the hierarchically lower level in the IL connection (downstream towards the load)

Two different types of connection are possible:

- *Point-to-Point connection*: provision of one master and one slave only (two CB/relays)
- *Multi-Point connection*: providing only one master but several slaves (three or more CB/relays, up to 16)

Finally for each relay there is also:

- *Bus Downlink*: connects the relay to the lower hierarchical level (downstream)

- *Bus Uplink*: connects the relay to the master, and then to the hierarchically higher level (upstream). The Bus Uplink from the slave is then connected to the master's Downlink channel.

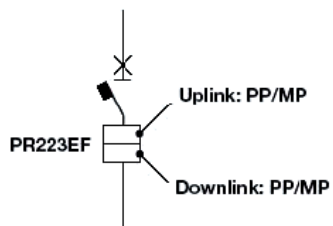
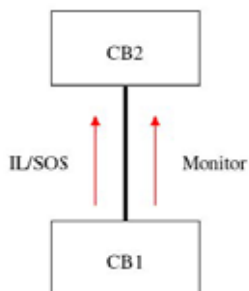

**Figure 3.** Connection and channels diagram for PR223EF.

Bus termination: if necessary, the line termination shall be carried out with AC terminators (R=100ohm series C=15nF).

**WARNING:** The type of connection must be configured for all the relays making up the IL chain.

Point-to-Point connection



**Figure 4.** Point-to-Point connection diagram

This connection is of the single direction type, the slave (CB1) sends both alarms and monitoring messages.

Multi-Point connection

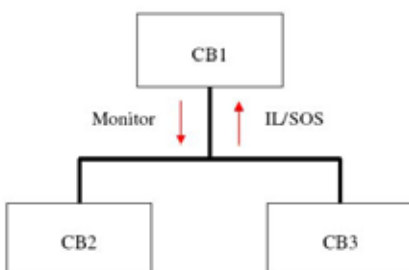

**Figure 5.** Multi-Point connection diagram

This is a connection of the two-directional type: the master (CB1) sends monitoring messages while the slaves (CB2 and CB3) send alarm messages.

Some typical connection configurations are shown in the figure below

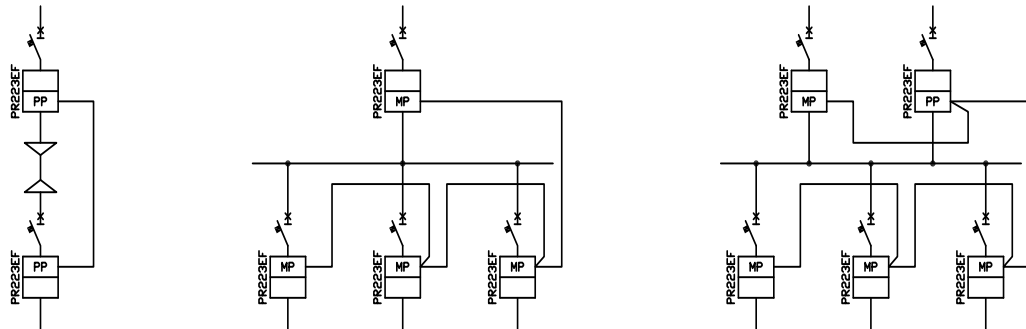

Figure 6. Examples of interlock configurations

Using PR223EF with software version 02.xx connected to PR223EF with software version 03.xx or later, it is necessary setting on these last ones the previous kind of interlock ( max 200 meters).

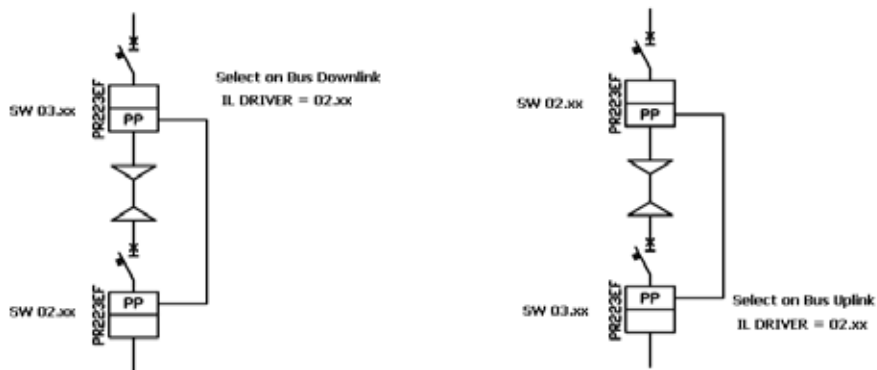

Figure 7. Examples of interlock configurations between trip units with different software versions.

#### 4.6.3. SOS Function

When after a EF, S or G trip the relay finds that the command to the Trip Coil has not had an effect and the fault condition persists, this requires backup action from the master relay through sending the SOS message.

The SOS message is handled as a matter of priority by the master relay which controls opening of the CB after it has checked that an alarm condition is present (active interlock signal received by the downlink bus).

:

---

## 4.7. Measuring functions

Measurements, except for current measurements, are available in the case of an auxiliary power supply.

The measurements can be displayed as follows:

- Front display unit FDU (see section 10.4. Display unit FDU) also when self-powered.
- HMI030 display unit (see section 10.5. HMI030 display unit), with Vaux.
- PR010/T test and configuration unit (see section 10.1. PR010/T test unit) even when self-powered.
- On PDA or Pc, through the BT030 connection unit (see section 10.3. BT030 connection unit).
- Remote supervision system.

### 4.7.1. Current measurements

The PR223EF release is capable of providing a measure of the currents in the three phases, the neutral, the earth current and the peak factors.

The minimum displayable current is 10%  $I_n$ .

Range	0.2...1,2x $I_n$
Accuracy of measurement	+/-3 % +/-1 digit

**Table 8.** Current measurement accuracy

### 4.7.2. Voltage measurements

For this measurements Vaux and the VM210 module must be present (see section 10.6. Voltage Module VM210).

The PR223EF unit is capable of providing measurements of the voltages in the three phases and if present the neutral and phase- to- phase voltages.

The measurable phase voltage range is 50 Vac - 1200 Vac.

Range	100...1000V
Accuracy of measurement	+/-1 % +/-1 digit

**Table 9.** Voltage measurement accuracy

### 4.7.3. Frequency measurements

For this measurement Vaux and the VM210 module must be present (see section 10.6. Voltage Module VM210).

The value of the rated mains frequency is set by the user configuring the appropriate parameter (50 Hz or 60 Hz).

If the value found differs from the set value by more than 10%, a "Frequency out of range" alarm is signalled on the system bus.

Frequency measurement is not available for voltage values lying within the range specified in 4.7.2. Voltage measurements.

Range	45...66 Hz
Accuracy of measurement	+/-2 % +/-1 digit

**Table 10.** Frequency measurement accuracy

---

## 4.8. INFORMATION

The information is available when there is an auxiliary power supply.

The information can be displayed through:

- Front display unit FDU (see section 10.4. Display unit FDU) also when self-powered.
- HMI030 display unit (see section 10.5. HMI030 display unit), with Vaux.
- PR010/T test and configuration unit (see section 10.1. PR010/T test unit) even when self-powered.

- 
- On PDA or Pc, through the BT030 connection unit (see section 10.3. BT030 connection unit).
  - Remote supervision system.
  - For details on information available consult the document, PR223EF Modbus™ System Interface doc. 1SDH000566R0002.

#### 4.8.1. Trip history

PR223EF has a historical database into which it records the latest trip events in time sequence: there is an index going from 1 (most recent) to 20 (least recent). This function is also available if Vaux is absent.

##### 4.8.1.1 Trip Report

The PR223EF device places the data for the last trip which it detected in memory. The information placed in memory is:

- Currents (L1, L2, L3, Ne) which have resulted in opening
- CB/Relay status
- Alarms
- Trip
- Type of protection tripped
- Parameters for the protection tripped

Recording of curves when the trip condition is detected.

The CB opens on receiving a SOS request. This operation is saved as a trip.

---

## 4.9. Communication

- The PR223EF device communicates with external devices via the system bus (see section 10.5. HMI030 display unit) (see section 10.7. PR021/K signalling unit) or control system through the RS485 serial (W1) with Modbus RTU protocol. For details of the protocol see document PR223EF Modbus™ System Interface doc. 1SDH000566R0002.

The communication parameters to the remote system can be configured through a PR010/T unit or ABB SACE SD TestBus2 software:

Parameter	Range	Default value
Address	1 ... 247	247
Baud Rate	9600   19200 bit/s	19200 bit/s
Parity	Even   Odd   None	Even
Type of address	Standard   ABB	Standard

**Table 11.** Communication parameters on the system bus

---

## 4.10. Test

### 4.10.1. Self-diagnosis

The PR223EF unit is provided with some self-diagnosis functions which can ensure that the release handles malfunctions correctly.

The PR223EF's self-diagnosis can be used to check:

- Presence of auxiliary power supply
- TC Connection
- Self-diagnosis of correct microprocessor and miscellaneous electronic component functioning
- Interlock monitoring
- Parameter congruence
- Status of the Aux-E and DFU (when connected)

### 4.10.2. Test unit

Using the PR010/T unit (see section 10.1. PR010/T test unit) connected to the relay it is possible to carry out a complete series of tests with a report which can be downloaded to a PC.

### 4.10.3. Trip Test Unit

Functioning of the TC and release electronics is tested using unit TT1 (see section 10.2. TT1 test unit).

### 4.10.4. Electronic Trip Test

A command is sent to release PR223EF via the system bus.

Functioning of the TC and the release electronics is tested in this way.

### 4.10.5. Autotest

The unit also provides for the possibility of carrying out a certain number of tests to check that the board is fully operational by activating the mode described as "Self-test".

When the self-test is in progress the protection functions are temporarily suspended.

If all the tests yield a positive outcome the unit resumes its normal operating status in automatic mode (within 10 seconds).

If one of the tests yields a negative outcome the device will lock up and display WATCHDOG on the front.

The self-test function may be activated either locally when starting up the device with Vaux (Start-Up with Rem-Loc push button pressed for at least 1s).

## 5 USER INTERFACE

### 5.1. Front plate

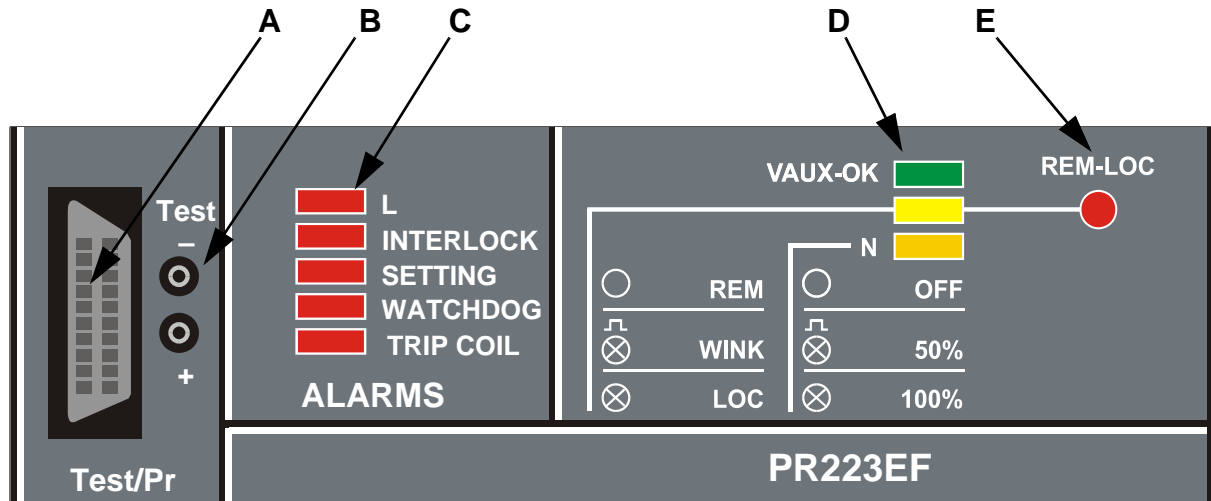

Figure 8. Front plate of the PR223EF unit

#### Key

- A TEST connector for the accessories PR010/T and BT030.
- B TEST connector for the accessory TT1.
- C Led unit to signal release alarms.
- D Led unit for indicating the status of the release.
- E Push button for the selection of operating mode (Local/Remote) and to carry out the Self-Test operation.

### 5.2. Meanings of alarm and status leds

Table 12. Meanings of the leds on the front of PR223EF

LED	Colour	Meaning		
		OFF	ON	Flashing (2 Hz)
L	Red	No alarm	L pre-alarm	L alarm
Interlock	Red	No alarm	IL bus malfunction	---
Setting	Red	Set parameters	Default parameters	---
Rem/Loc/Wink	Yellow	Remote	Local	Wink
N	Yellow	Neutral=OFF	Neutral=100 %	Neutral=50 %
Watchdog	Red	No alarm	µP malfunction or current < 0,18xIn	Oscillator blocked
Trip Coil	Red	TC OK	TC missing or cabling problems	---
VAUX – OK	Green	Auxiliary power supply off	Auxiliary power supply on	---

---

## Explanation of LEDs

- L

Operated both under auxiliary power and when self-powered.

Flashes at 2 Hz in the case of a pre-alarm and shows a fixed light in the case of a protection alarm.

- Interlock

Only operated under auxiliary power when the interlock function is only active under that condition.

Lit if the IL is not functioning (no MONITORING message)

- Setting

Operated both under auxiliary power and when self-powered.

Lit if the user has not yet altered the default settings.

- Rem / Loc / Wink

Only operated under auxiliary power when communication to the remote system is only active under that condition.

The "Rem/Loc" signal is linked to pressing the corresponding push button for at least 1s.

The "Wink" signal is associated with a command originating from the remote system to physically identify the device.

Changeover to "Local" mode is a priority over the "Wink" state.

- N

Operated both under auxiliary power and when self-powered.

This led shows the setting status of the neutral (see section 4.5. Protection functions).

- Watchdog

Operated both under auxiliary power and when self-powered.

If lit, indicates a probable release malfunction.

If it is flashing the oscillator is blocked. The trip unit will continue to protect with less accuracy.

- Trip Coil

Operated both under auxiliary power and when self-powered.

If lit, indicates a TC connection/function problem.

---

### 5.3. REM-LOC push button

This push button is used to select the operating mode (Local/Remote). This push button also makes it possible to carry out the device self-test (see section 4.10.5. Autotest).

In remote mode all operations are transferred to the remote system.

In local mode it is not possible to change parameters, and opening/closing commands sent from remote are carried by the system bus.

## 5.4. Default settings

The PR223EF is supplied by ABB SACE with the following preset parameter:

#	Parameter	On/Off	Value	Time	Curve	Interlock
1	L	--	1 In	3 s	--	--
2	L Pre-alarm	On	0.9 In			
3	S	Off	3 In	0.5 s	$I^2t=K$	On
4	I	Off	5,5 In	--	--	--
5	G	Off	1 In	0.8 s	--	On
6	EF	On	--	--	--	On
7	Trip delayed	Off	--	--	--	--
8	Up-link	--	Multi-point	--	--	--
9	Down-link	--	Point-to-Point	--	--	--
10	Frequency	--	50 Hz	--	--	--
11	VM210 N presence	--	Off	--	--	--
12	Neutral	On	50%	--	--	--

**Table 13.** Default settings (preset by ABB SACE)

---

## 6 SETTING UP

---

### 6.1. Connections

**WARNING:** For the connections provided by the user, it is recommended that you comply strictly with the recommendations contained in this document. This will enable us to satisfy all the international reference standards and guarantee perfect operation of the relay even under severe environmental and electromagnetic conditions. Pay particular attention to the types of cable, the earth connections and the recommended maximum distances.

---

### 6.2. Test

Before it is put into service a test can be performed by using the specific external unit PR010/T and TT1.

A positive outcome to this test is shown by the CB opening.

It is recommended that a self-test should also be carried out (see section 4.10.5. Autotest).

---

### 6.3. Initial settings

**WARNING:** It is absolutely essential that the user should carefully define each modifiable parameter before putting the PR223EF into service.

## 7 OPERATING INSTRUCTIONS / OPERATION IN SERVICE

### 7.1. Programming

One of these systems may be used to programme the PR223EF device:

- PR010/T test and programming unit (see section 10.1. PR010/T test unit) connected to the front test connector
- Programming via the system Bus using ABB SD-TestBus2 software
- Programming via BT030 using ABB SD-Pocket software (see section 10.3. BT030 connection unit)
- Programming via the system bus using the supervision system (for example ABB SD-View 2000).

Changing protection functions

The protection functions for the PR223EF release can be configured within the values shown in the following table:

**Table 14.** Selectable values for configuring protections

Protection	Disabling	Interlock (IL)	Trip delayed	Threshold Range	Time Range	Threshold tolerance	Time tolerance
L ( $t=k/i^2$ )	<input type="checkbox"/>	<input type="checkbox"/>	<input type="checkbox"/>	$0.18xI_n \leq I_1 \leq 1xI_n$ step $0.01xI_n$	@ $6xI_n \ 3s \leq t_1^1 \leq 18s$ , step $0,5s$	=	$\pm 10\%$ , $I_1 < 6xI_n$ $\pm 20\%$ , $I_1 \geq 6xI_n$
S ( $t=k$ )	<input checked="" type="checkbox"/>	<input checked="" type="checkbox"/>	<input type="checkbox"/>	$0.6xI_n \leq I_2 \leq 10xI_n$ step $0.1xI_n$	$0.05s \leq t_2 \leq 0.5s$ , step $0.01s$	$\pm 10\%$	$\pm 10\%^2$
S ( $t=k/i^2$ )	<input checked="" type="checkbox"/>	<input checked="" type="checkbox"/>	<input type="checkbox"/>	$0.6xI_n \leq I_2 \leq 10xI_n$ step $0.1xI_n$	@ $8xI_n \ 0.05s \leq t_2 \leq 0.5s$ , step $0.01s$	$\pm 10\%$	$\pm 10\%$ , $I_2 < 6xI_n$ $\pm 20\%$ , $I_2 \geq 6xI_n$
I ( $t=k$ )	<input checked="" type="checkbox"/>	<input type="checkbox"/>	<input type="checkbox"/>	$1.5xI_n \leq I_3^a \leq 12xI_n$ step $0.1xI_n$	Instantaneous	$\pm 10\%$	
G ( $t=k/i^2$ )	<input checked="" type="checkbox"/>	<input checked="" type="checkbox"/>	<input type="checkbox"/>	$0.2xI_n \leq I_4 \leq 1xI_n$ step $0.1xI_n$	$0.1s \leq t_4 \leq 0.8s$ , step $0.01s$	$\pm 20\%$	$\pm 20\%$
EF	<input checked="" type="checkbox"/>	<input checked="" type="checkbox"/>	<input checked="" type="checkbox"/>	--	--		
Iinst	<input type="checkbox"/>	<input type="checkbox"/>	<input type="checkbox"/>	$>12I_n$	Instantaneous	$\pm 20\%$	10%

1. For T4 with  $I_n = 320$  A, T5 with  $I_n = 630$  A and T6 with  $I_n = 1000$  A;  $t_1 = 10,5s$  max,  $I_2$  and  $I_3 = 9,5I_n$  max, T6 with  $I_n=800A$   $I_3 = 10,5I_n$  max
2. Tolerance  $\pm 10$  ms up to  $t_2=0.1$  s

# 8 TROUBLESHOOTING

The following table lists a series of typical service conditions, to help you understand and solve hypothetical faults or malfunctions.

**N.B.:**

1. Before consulting the following table, check for a few seconds for any signals provided by the led.
2. FN indicates the normal operation of the PR223EF.
3. If the suggestions proposed do not lead to a solution of the problem, please contact the ABB SACE assistance service.

**Table 15.** Possible causes of error.

No.	Situation	Possible causes	Suggestions
1	Trip times lower than expected	<ol style="list-style-type: none"> <li>1. Threshold too low</li> <li>2. Curve too low</li> <li>3. Incorrect selection of Neutral</li> </ol>	<ol style="list-style-type: none"> <li>1. Correct threshold</li> <li>2. Correct curve</li> <li>3. Correct neutral selection</li> </ol>
2	Trip times longer than expected	<ol style="list-style-type: none"> <li>1. Threshold too high</li> <li>2. Curve too high</li> <li>3. Curve I<sup>2</sup>t enabled</li> <li>4. Incorrect selection of Neutral</li> <li>5. Oscillator fault</li> </ol>	<ol style="list-style-type: none"> <li>1. Correct threshold</li> <li>2. Correct curve</li> <li>3. Exclude if not necessary</li> <li>4. Correct neutral selection</li> <li>5. If watchdog led is flashing, restart the PR223EF.</li> </ol>
3	Fast trip with I3=Off	Inst tripped	FN with short-circuit at high I
4	High earth I, but no tripping	Function G prevented with I>4In	FN
5	V Reading	VM210 incorrectly connected	Check VM210 connections
6	Anomalous led indications	Miscellaneous faults	(see section 5.2. Meanings of alarm and status leds)
7	Remote commands or settings not actuated	Relay set to local "Loc"	Push appropriate push button and set to remote "Rem"
8	Interlocking led lit	IL lines incorrectly connected	Check IL connections
9	Interlocking led lit	Relay with SW 02.xx connected with relay with Sw 03.xx	Modify the interlock typology ( IL DRIVER) of relay with SW 03.xx from DEFAULT to 02.xx
10	Not possible to carry out the trip test with TT1	Current is flowing	FN, the test is only carried out if the current is zero

---

## 9 WARNING

---

### 9.1. In the event of a fault

If the PR223EF is suspected of being faulty, there are signs of malfunctions or it has tripped unexpectedly, we advise you to strictly follow the recommendations below:

1. Do not reset the relay.
2. Check if any indicator lights (leds) on the front are lit.
3. After a trip the relay will have placed the most important data in memory, so it is recommended that these be displayed through the display system.
4. Note down the type of circuit-breaker, number of poles, any accessories connected, In, Serial Number, SW version.
5. Prepare a brief description of opening (when did it happen?, how many times?, was it always under the same conditions? what type of load? what voltage? what current? is the event reproducible?)
6. Send/communicate all the information collected, together with the circuit diagram for the circuit-breaker, to your nearest ABB Customer Support service.

**WARNING:** The completeness and accuracy of the information given to the ABB Support service will facilitate technical analysis of the problem encountered, and will allow us to carry out all actions useful for the user rapidly.

---

# 10 ACCESSORIES

---

## 10.1. PR010/T test unit

The test with the PR010/T unit enables you to check the proper operation of the inputs, outputs, thresholds and the tripping times of the protection functions. It is also possible to obtain a test report and change all the settings for the PR223EF unit.

The unit is connected to the PR223EF release through the front connector. The PR010/T unit provides a current and tests the L, S, I, G protection algorithms.

When connected the system bus is disconnected.

For operation of the PR010/T accessory consult the appropriate user manual.

---

## 10.2. TT1 test unit

The test with the TT1 unit is used to check that the TC is operating correctly. The device is connected to the appropriate front connector.

---

## 10.3. BT030 connection unit

The BT030 is a temporary Bluetooth communication unit.

This connects to the release through the front connector. Using this module in combination with the SD-Pocket Sw installed on a PDA (palm computer) or a portable PC (Laptop) it is possible to communicate via Bluetooth to change settings, analyse measurements, send commands, read trip history, etc.

---

## 10.4. Display unit FDU

The front display FDU is a display unit fitted to the front of the circuit-breaker. It is incompatible with front-mounted accessories: rotary handle control, motor control and front flange for lever control.

The unit also operates on a self-powered basis.

---

## 10.5. HMI030 display unit

The HMI030 interface is a display unit installed on the front of the switchboard. It consists of a graphic display and navigation push buttons.

The HMI unit is connected to the release through the system bus.

The unit needs Vaux, and is an alternative to connection of the PR223EF release to a supervision system.

---

## 10.6. Voltage Module VM210

When this module is connected to release PR223EF a variety of additional electrical quantities can be measured (see section 4.7.2. Voltage measurements)(see section 4.7.3. Frequency measurements).

---

## 10.7. PR021/K signalling unit

The PR021/K signalling unit can be used to signal the status of the protection functions and the trip of PR223EF itself through the power contacts (250 Vac, 5 A) when connected to the PR223EF system bus.

The user is able to "combine" the alarm signals from the PR223EF release with each of the 7 K51 power relays within the PR021/K individually.

The unit needs Vaux, and is an alternative to connection of the PR223EF release to a supervision system.

For the installation and operation of the PR021/K accessory see the specific user manual.

---

## 10.8. SW210 switch module.

The SW210 switch module reverses the connections of the interlock bus ( Downlink <=>Uplink ) .

This module can be used in open loop network in order to keep the opposite direction of the interlock with the power flow.

# 11 APPENDIX

## 11.1. Trip curves

The trip curves provided are merely for guidance and only show a sub-group of the possible selections.

### PR223EF - Vaux ON

### T4L 250/320 - T5L 400/630 - T6L 630/800/1000

### L-S-EF Functions

Note

The dotted curve of function L corresponds to the maximum delay ( $t_1$ ) which can be set at  $6 \times I_1$  in the case where 320A CTs are used for T4 and 630A for T5. For all the CT sizes  $t_1 = 18s$  except with 320 A CT (T4) and 630A CT (T5) where  $t_1 = 10.5s$ .

For T4  $I_n = 320A$ , T5  $I_n = 630A$  and T6  $I_n = 1000A \Rightarrow I_2 \text{ max} = 9.5 \times I_n$ . For T6  $I_n = 800A \Rightarrow I_3 \text{ max} = 10.5 \times I_n$

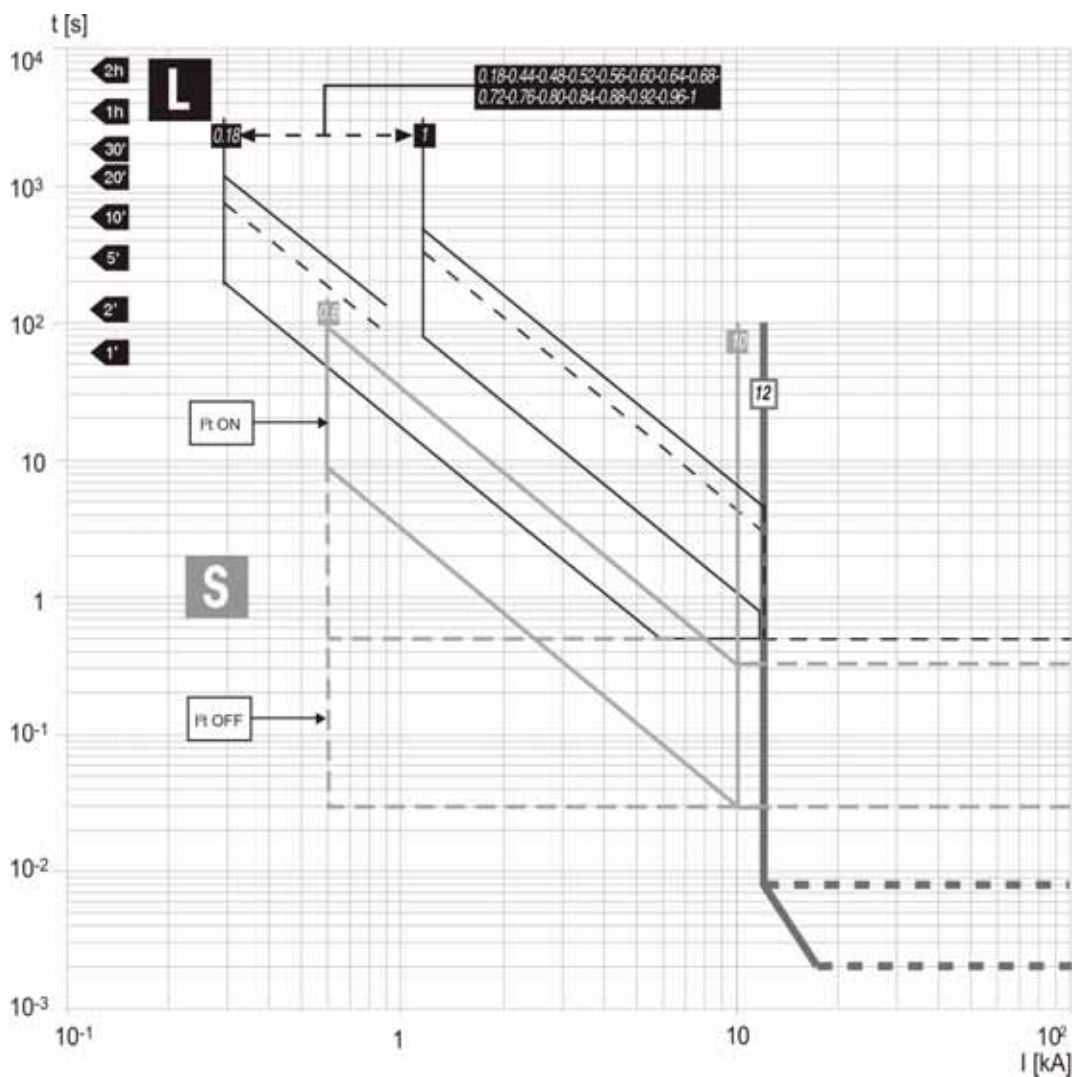

**PR223EF - Vaux OFF**

**T4L 250/320 - T5L 400/630 - T6L 630/800/1000**

**L-S- I Functions**

Note

The dotted curve of function L corresponds to the maximum delay ( $t_1$ ) which can be set at  $6 \times I_l$  in the case where 320A CTs are used for T4 and 630A for T5. For all the CT sizes  $t_1 = 18s$  except with 320 A CT ( T4) and 630A CT ( T5) where  $t_1 = 10.5s$ .

For T4  $I_n = 320A$ , T5  $I_n = 630A$  and T6  $I_n = 1000A \Rightarrow I_2 \text{ max} = 9.5 \times I_n$ . For T6  $I_n = 800A \Rightarrow I_3$

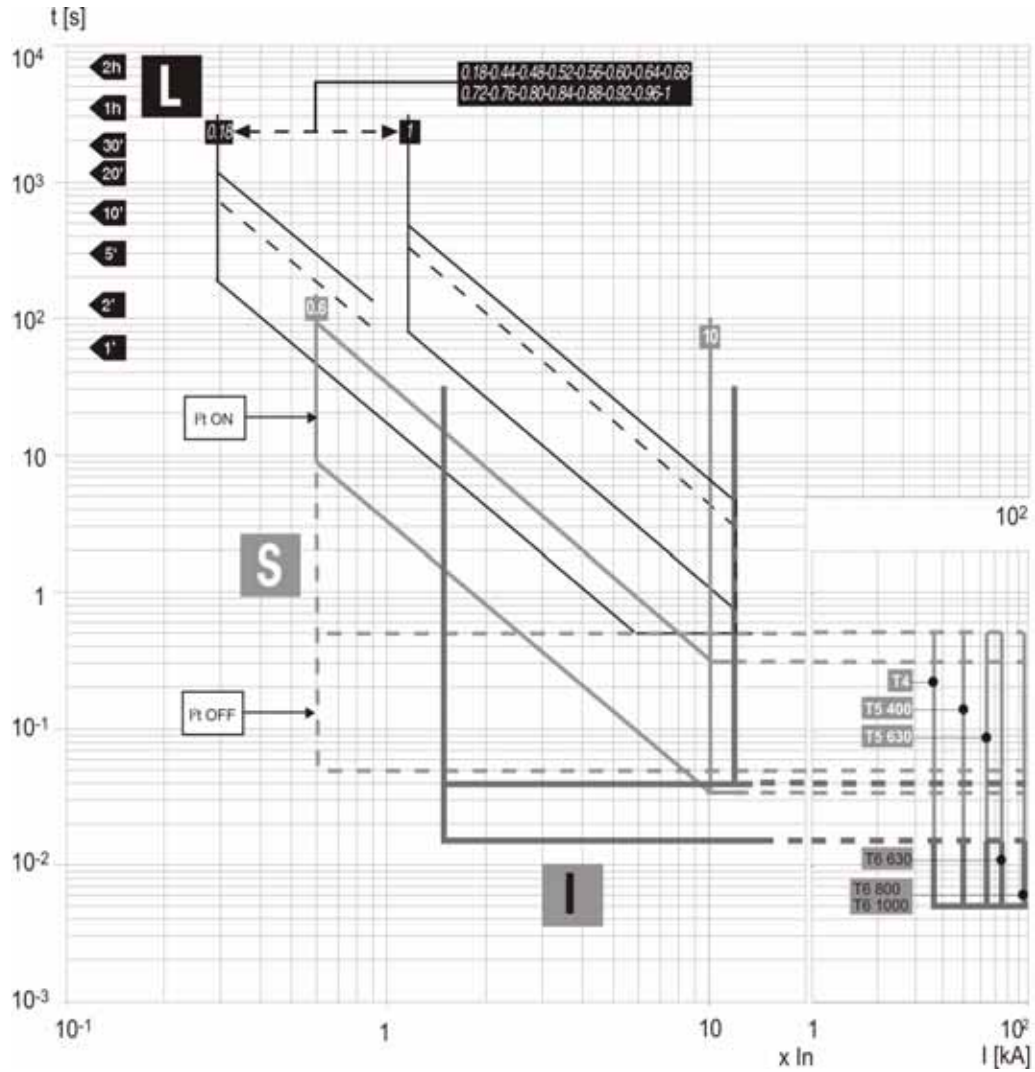

PR223EF - Vaux ON/ OFF  
 T4L 250/320 - T5L 400/630 - T6L 630/800/1000  
 G Function

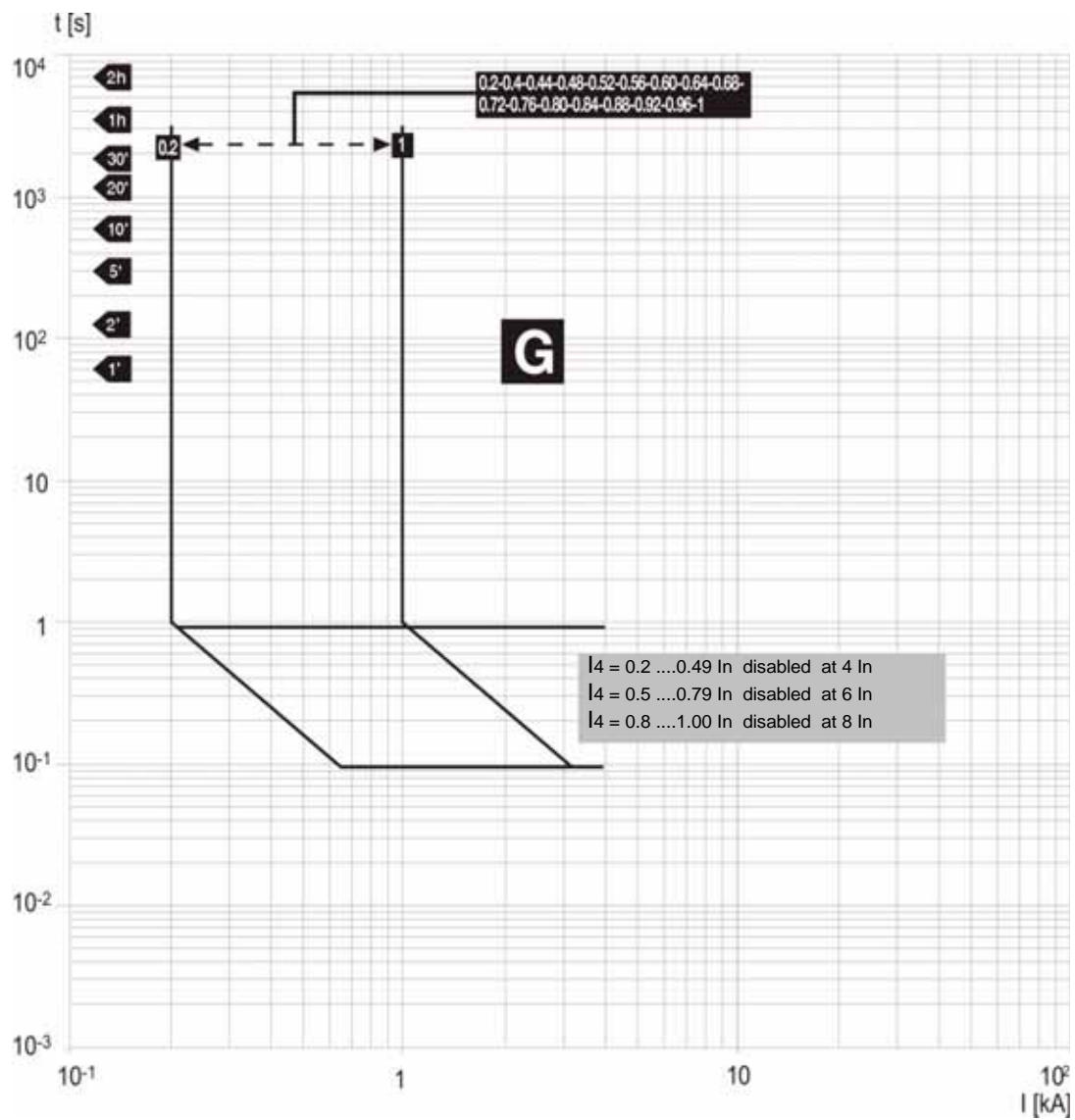

## 11.2. Wiring diagram

Application diagram for PR223EF with VM210

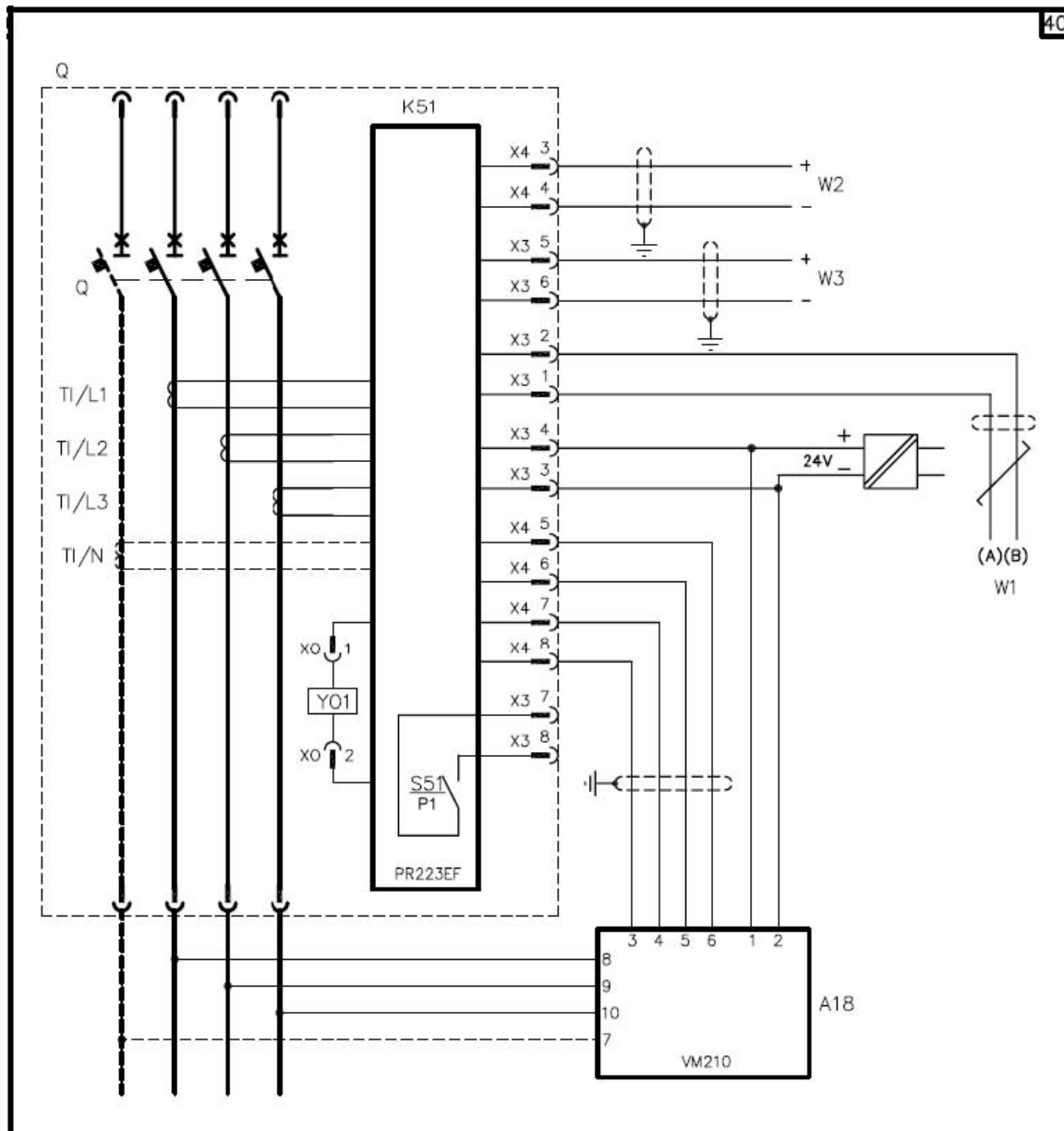

---

**Key**

---

□	= Figure number of the diagram
K51	= Electronic release: <ul style="list-style-type: none"><li>- PR223EF overcurrent release, with the following protection functions</li><li>- L overload protection with inverse long time-delay trip</li><li>- S short-circuit protection with inverse or definite short time-delay trip</li><li>- I short-circuit protection with instantaneous time-delay trip</li><li>- G protection against earth faults with inverse short time-delay trip</li></ul>
Q	= Main circuit-breaker
S51/P1	= Programmable contact for electrical signalling of overload in progress
TI/L1	= Current transformer located on phase L1
TI/L2	= Current transformer located on phase L2
TI/L3	= Current transformer located on phase L3
TI/N	= Current transformer located on neutral
W1	= System bus (EIA RS485 interface) to the control system
W2	= Uplink communication bus for interlock to the upstream circuit-breaker
W3	= Downlink communication bus for the interlock to the downstream circuit-breaker
X3,X4	= Connectors for the circuits of the electronic overcurrent release (with plug-in circuit-breakers, the connectors are pulled out at the same time as the circuit-breaker).
YO1	= Opening solenoid of the electronic overcurrent release

---