



Actively improving quality

ABB's PQC active filters enhance system performance and efficiency

KURT SCHIPMAN, FRANÇOIS DELINCÉ – The increasing use of non-linear loads in all types of industrial and commercial applications has resulted in the introduction of potentially harmful current harmonics into the power network that can lead to overheating of cables, motors and transformers, damage to sensitive equipment, tripping of circuit breakers and blowing of fuses as well as premature aging of the installation.

ABB modular PQC active filters provide a reliable and cost-effective solution to this problem by continuously monitoring the current in real time to determine what harmonics are present and then injecting harmonic currents in the network with exactly the opposite phase to the components that are to be filtered. The two harmonics effectively cancel each other out so that the feeding transformer sees a clean sine wave.

1 Examples of financial loss due to power quality incidents

Sector	Financial loss per incident (in euros)
Semi-conductors production(*)	3.8 million (\$5.3 million)
Financial trade(*)	6 million (\$8.4 million)
Computer center(*)	750,000 (\$1 million)
Telecommunication(*)	30,000 (\$42,000)
Steel industry(*)	350,000 (\$490,000)
Glass industry(*)	250,000 (\$350,000)
Offshore platforms	250,000 - 750,000 (\$350,000 - \$1 million)
Dredging/land reclamation	50,000 - 250,000 (\$70,000 - \$350,000)

overview of typical financial losses due to a power quality incident (stop) in electrical installations for various industries [1]. The data marked as (*) have been concluded after a European-wide power-quality survey undertaken by the European Copper Institute in 2002. The remaining information is based on ABB data.

One possible method to quantify theoretically the extra losses introduced by harmonics in transformers is to use the IEEE C57.110 standard [2]. The calculated impact will depend on the local situation but what is clear is that losses quickly accumulate.

Most of the harmonic pollution nowadays is created as harmonic current produced by loads in individual installations. This harmonic current, injected into the network impedance is translated into harmonic voltage (Ohm's law), and then ap-

This can result in operational issues in the other installations.

Most utility plants have adopted and comply with power quality standards and regulations to limit this type of problem. Non-compliance with these regulations leads to a refusal of a new installation connection.

Addressing harmonic pollution and load imbalance

Historically, passive filters have been proposed to mitigate harmonic pollution. In low-voltage (LV) installations, these solutions become less and less applicable when:

- LV installations are very dynamic leading to relatively fast passive filter overload
- Modern loads (eg, variable-speed drives, modern lighting systems) already have a very good $\cos \varphi$ (possibly even capacitive) leading to overcompensation when a passive filter is installed. This in combination with the limited capability of typical backup generators to run on capacitive $\cos \varphi$ reduces the reliability of the installation.
- Passive filters installed in LV installations typically address the lower harmonic orders. Currently, however, it is the higher frequency harmonics that are problematic in installations.
- The filtering efficiency of a passive filter is defined by the ratio of the passive filter impedance and the network impedance and therefore cannot be guaranteed. Hence, it is virtually impossible to guarantee compliance with regulations by using passive filters.

For these reasons there is a worldwide tendency to move away from passive filtering solutions in favour of active filtering solutions in LV and MV applications.

Electrical networks with poor power quality result in financial loss, environmental impacts or safety concerns. There are three significant causes of poor power quality:

- Harmonic pollution
- Load imbalances resulting in voltage imbalance
- Reactive power

These conditions, when excessive, lead to frequent equipment failures or reduced lifetime of the equipment, production losses, reduced safety levels of installations, increased carbon footprint, non-compliance with utility regulations and other undesired effects. In addition to financial losses there are costs incurred due to extra kWh losses in typical network components such as transformers, cables and motors. These losses are cascaded back to the utility power plants and, depending on the process and fuel from which the electrical power is generated, result in increased CO₂ emissions. Nuclear power plants, for example, have almost no CO₂ footprint per kWh while coal power plants generate around 900 to 1,000 g/kWh.

If, due to poor power quality, the production is stopped, major costs are incurred. This is illustrated in → 1, which gives an

ABB modular PQF active filters are used to counter the effect of potentially harmful current harmonics into the power network.

plied to all the loads within that user's installation. In addition, the harmonic current produced in one installation, if not filtered, will also flow through the feeding transformers into the utility supply and create harmonic voltage distortion on the public network. As a result, any utility user connected to the same supply will become affected by the pollution created by another utility customer.

2 Connection diagram of the most commonly found active filters

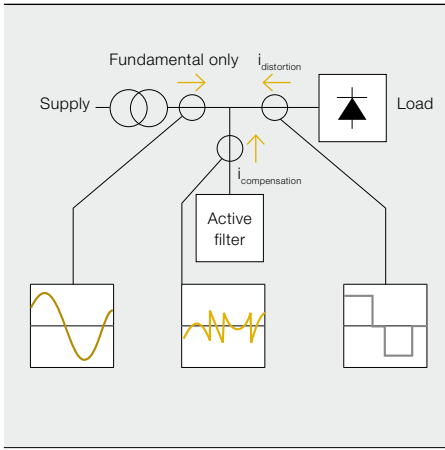

3 Closed-loop and open-loop active filter principle

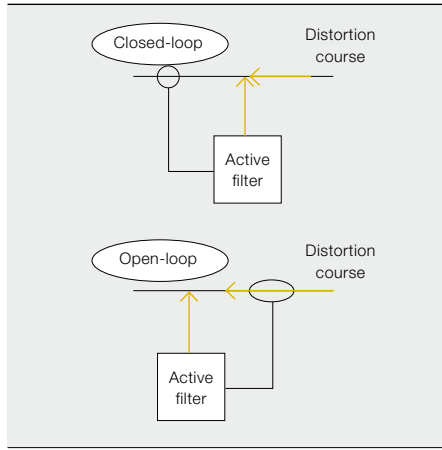

4 Principle of the frequency-domain filtering approach

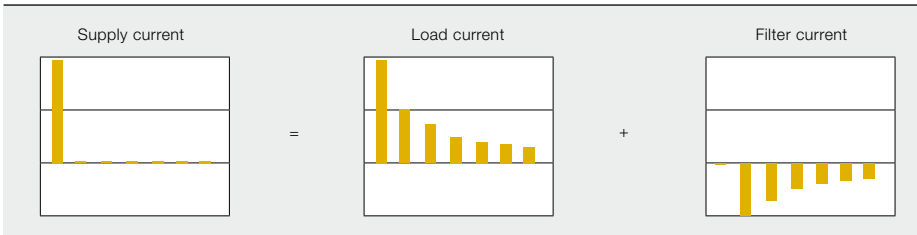

The most commonly found active filters are power electronics-based electrical equipment that are installed on a parallel feeder to the polluting loads → 2.

The controller of an ABB power quality filter (PQF) analyzes the line current harmonics, as well as the customer requirements. It can then generate for each harmonic frequency a harmonic current (compensation current) that is opposite in phase to the measured polluting current.

Since the PQF does not operate according to the conventional low harmonic impedance principle employed by passive filters, it remains unaffected by changes in network parameters and can not be overloaded. Also, compared to passive filter units, active units can be easily extended.

In order to obtain effective performance throughout the filter bandwidth, two control aspects, both of which can be implemented in the PQF, are critical:

- The use of a closed-loop control system
- The frequency domain approach for processing and controlling the polluted current.

For active filters the closed-loop and open loop aspect can be found in the location where the active filter measurement current transformers (CTs) have to be installed → 3.

The tendency now is to move away from passive filtering solutions in favour of active solutions in low and medium-voltage applications.

In closed-loop systems, the current upstream of the load and filter connection are measured and corrective action is taken. Any measurement or other inaccuracies can be automatically cancelled out and compensated by the closed-loop concept. In open-loop systems, the load current is measured and processed and the resultant inverted signal drives the insulated gate bipolar transistor (IGBT) bridge. As no feedback exists, the resulting line current may typically contain er-

ror components, which are not detected by the control system.

In summary, the advantages of using a closed-loop system over an open-loop one are [3]:

- Closed-loop systems allow the canceling of errors in the control loop and in the behavior in response to external disturbance. Open-loop systems do not have this capability.
- Closed-loop control systems can react as fast as open-loop control systems providing that the control loop parameters are set for this behavior.

The frequency domain approach is preferred over the time domain approach, and the following paragraph explains why.

In the time-domain approach, the fundamental frequency component is removed from the measured current signal. The remaining waveform is then inverted and the resultant signal drives the IGBT-bridge of the active filter. This approach ignores the fact that the network characteristics are different for different frequencies, as well as the characteristics of the CT's and the control system. The performance of active filters using this control approach deteriorates with increasing frequency. In the frequency-domain approach each harmonic and its corresponding system characteristics are treated individually and performance can be optimized for the harmonic components in the filtering bandwidth. As a result the same (high) filtering performance can be maintained through the filtering bandwidth. The principle of the frequency-domain filtering approach is illustrated in → 4.

The best filtering performance will be obtained with an active filter using a closed-loop control system and an individual frequency domain approach. Other advantages of such filters include:

- User requirements can be preset for each harmonic (eg, standard compliance requirement).
- Individual harmonics can be selected to allow optimal use of the filter resources (eg, no need to filter the fifth harmonic if this harmonic is already filtered by another existing filtering device).

5 Example of a balancing application by using a closed-loop active filter

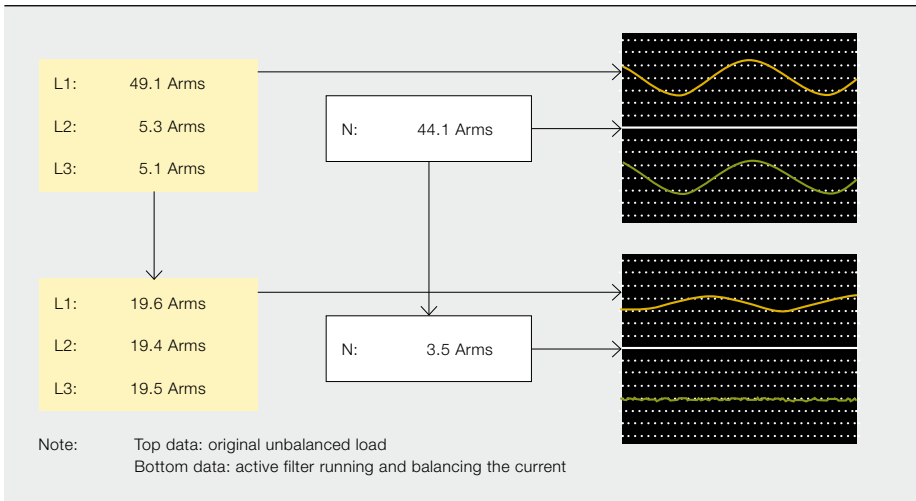

The best filtering performance will be obtained with an active filter using a closed-loop control system and an individual frequency domain approach.

- Precise targets for $\cos \varphi$ can be set and maintained. This allows such active filters to operate in applications where accurate $\cos \varphi$ control is required to avoid disturbances in the installation (e.g. tripping of a generator). ABB active filter units can compensate both inductive and capacitive loads.
- Precise load balancing can be implemented allowing neutral systems to be offloaded and ensuring that neutral to earth voltage is kept to minimal levels. Also, it can be ensured that the load seen by eg, a UPS is balanced. → 5 gives an example of a balancing application by using a closed loop control ABB PQF active filter.

In addition to the functional aspects, more advanced active filters such as the ABB units contain functions that minimize equipment running losses and provide extra reliability to the installation. This is due to the presence of valuable secondary functions (eg, automatic temperature de-rating function etc.).

Field results

ABB PQF active filters and other ABB power quality equipment are applied in several fields.

For example, an oil field exploitation facility comprises one central power station feeding many pumping clusters. The vast majority of the loads are AC drive controlled. There are approximately 40 clusters, each with a load in the range of 2 MW. Without active filters, the total harmonic distortion voltage (THDV) at the LV side of the cluster would be equal to 12

percent and the total harmonic distortion current (THDI) would be 27 percent → 6.

With active filters, the THDV has been reduced to 2 percent and THDI to 3 percent → 7.

Overall, the power quality of the clusters has been hugely improved, allowing the plant to run within IEEE 519 standard limits and ensuring trouble free operation of the different clusters.

A second example considers the power quality on board a vessel → 8. The vessel in question has an electrical power plant consisting of two generators running at around 600 kVA each. The main loads are two DC-drive based propulsion units. Before compensation, the THDI was around 25 percent and the corresponding THDV around 22 percent. The $\cos \varphi$ of the installation was around 0.76. Typical fuel consumption of the vessel was in the range 14,000 to 15,000 liters per month.

The customer requirements were to:

- Reduce the harmonic pollution to acceptable levels to avoid technical problems with the propulsion units.
- Perform reactive power compensation without the risk of overcompensation.

For this reason, ABB active filters were selected and installed. The customer feedback was highly encouraging since the technical problems were resolved and there was scope to save around 10 percent of fuel costs. On a yearly basis, the customer has the potential to save around 18,000 liters of fuel. The primary reason is that one generator could be switched off more frequently thanks to the improved network quality.

As seen in previous examples, power quality issues often arise in industrial networks due to the presence of a non-negligible number of (large) pollution loads. In commercial applications however, power quality is also a concern. In such applications, many single-phase polluting loads are present which create problems such as:

- Increased harmonic stress, which is put on equipment that is typically more vulnerable than industrial equipment.
- Resonance excitation due to the presence of 3rd harmonic compo-

6 Voltage (top) and current (bottom) waveforms before filtering at the LV cluster side

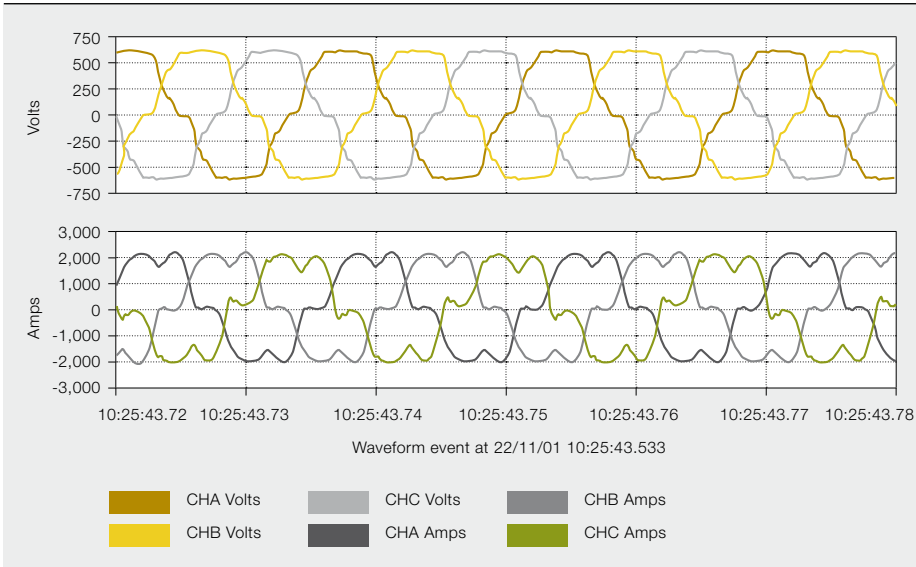

7 Voltage (top) and current (bottom) waveforms after filtering at the LV cluster side

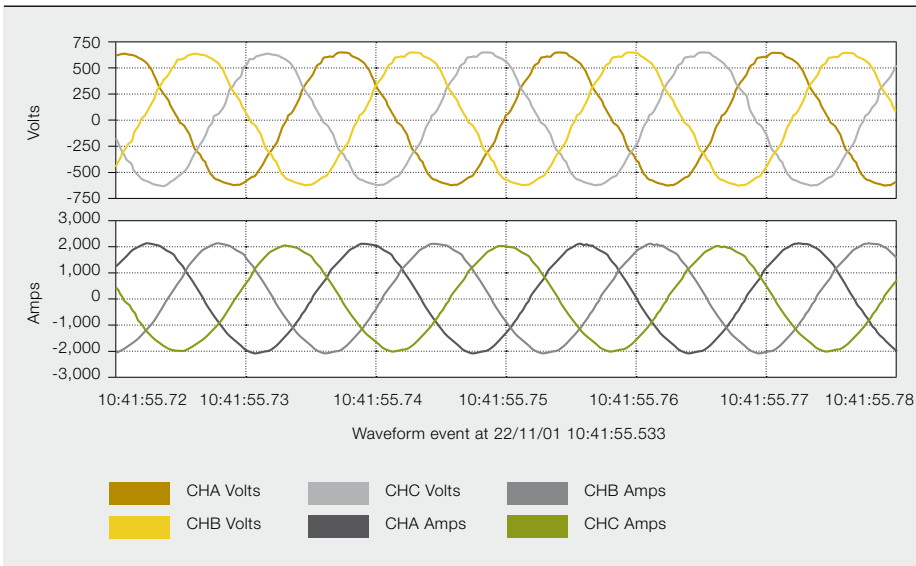

nents in combination with capacitor banks with a wrongly chosen detuning reactor or no reactor at all.

- Neutral currents in excess of neutral conductors and bus-risers rating.
- Too high neutral to earth voltages which may not be acceptable for product operation and/or from a safety point of view.
- The presence of capacitive $\cos \varphi$ due to modern server hardware, eventually leading to the need to derate UPS-systems etc.

An example of a commercial application is the power quality in a prestigious multi-star hotel. This hotel incorporates guest rooms, suites, function rooms and business centers. Typical loads encountered are high-speed lifts, dimmer switches and other sophisticated lighting equip-

ment, as well as typical office equipment including PCs, printers, etc. As a result of all these loads, the power quality had deteriorated to such an extent that the voltage was unstable. Simply changing the operating point of loads in one side of the building would affect the operation of other loads in other rooms. This was clearly unacceptable as it could lead to a loss of customers because of a low standard of service. ABB filtering equipment resolved these issues.

8 ABB reduced fuel consumption of this vessel by 10 percent



ABB PQC active filters contain additional functions that minimize equipment running losses and provide extra reliability to the installation.

Kurt Schipman
François Delincé
 ABB Power Products
 Charleroi, Belgium
 kurt.schipman@be.abb.com
 francois.delince@be.abb.com

References

- [1] European Copper Institute (2002). European power quality survey.
- [2] IEEE C57.110-2008: IEEE recommended practice for establishing transformer capability when supplying non-sinusoidal load currents. 2008.
- [3] Kuo, B.C. Automatic Control Systems. John Wiley & Sons, Inc. New York, NY, The United States.