

# MNS

Normal design



ABB LV Systems



# Contents

---

General _____	Page 3
Rated data _____	4 - 5
Service conditions _____	6 - 7
Design and construction _____	8 - 9
Protection against electric shock _____	10 - 11
Requirements related to accessibility for inspection _____	12 - 13
Short-circuit protection and short-circuit withstand strength _____	14 - 15
Parts included in assembly _____	16 - 17
Internal separation of assemblies by barriers and partitions _____	18 - 19
Requirements for electronic equipment supply circuits _____	20 - 21
Electromagnetic compatibility (EMC) _____	20 - 21
Type test _____	22 - 23
Routine test _____	22 - 23
Identification labels _____	24
Documentation _____	25
Examples of separately forwarded documentation _____	26 - 31
Symbols used in diagrams _____	32
Explanation of particulars in single-line diagrams _____	33

Switchgear assemblies of type MNS are designed and tested in compliance with EN 60 439-1 or IEC 439-1 Low Voltage Switchgear and Controlgear assemblies. At a number of places in the standard it states that '*agreement should be reached between manufacturer and user*'. In those cases where no special agreement is reached the switchgear will be delivered as per the information on normal design provided here.

The switchgear is available in its basic designs, which allow for different interpretations of IEC 439-1, as is apparent from this information brochure. The basic designs are:

- Apparatus cubicles with removable apparatus units
- Apparatus cubicles with withdrawable apparatus units
- Unequipped apparatus cubicles

The normal design described is intended for setting up in operation rooms and is to be attended by specially trained personnel.

The switchgear systems are very flexible and a number of other design forms can therefore be obtained, e.g. other enclosure classes, extra screening, adaptation to special environments, etc.

This information brochure contains both original excerpts from IEC 439-1 and particulars of the normal design that is supplied unless some other agreement is reached.

## Agreement between manufacturer and user

The following items are among those referred to by the expression '*agreement should be reached between manufacturer and user*'.

- 4.7 Rated diversity factor
- 6.1.1.2 (Note) Use of assemblies in an arctic climate
- 6.1.3 (Note) Use of electronic equipment at altitudes above 1000 m
- 6.2 Special service conditions
- 6.2.10 Electrical and radiated interferences
- 6.3.1 Conditions during transport, storage and erection
- 7.1.3 Terminals for external conductors
- 7.2.1.1 Degree of protection required for the intended installation. For floor-mounted assemblies also the degree of protection of the bottom to be indicated.
- 7.4.2 Choice of protective measure against direct contact
- 7.4.3 Choice of protective measure against indirect contact
- 7.4.6 Accessibility in service by authorized personnel
- 7.4.6.1 Accessibility for inspection and similar operations
- 7.4.6.2 Accessibility for maintenance
- 7.4.6.3 Accessibility for extension under voltage
- 7.5.2.3 Values of prospective short-circuit current for an assembly in case of several incoming or outgoing units for high-power rotating machines
- 7.5.4 Co-ordination of short-circuit protective devices
- 7.6.4.3 Degree of protection after removal of removable or withdrawable part
- 7.7 Form of internal separation
- 7.9.1 Input voltage variations for electronic equipment supply
- 7.9.4, b) Supply frequency deviation
- 8.2.1.3.4 Temperature-rise test for values of test current higher than 3150 A
- 8.2.1.6 Ambient air temperature during temperature-rise test
- 8.2.3.2.3, d) Value of test current in the neutral bar at short-circuit withstand test
- 8.3.1 Repetition of electric operation test on site

# Rated data according to IEC 439-1

**4.1 Rated voltages**  
An ASSEMBLY is defined by the following rated voltages of its various circuits:

**4.1.1 Rated operational voltage (of a circuit of an ASSEMBLY)**  
A rated operational voltage ( $U_o$ ) of a circuit of an ASSEMBLY is the value of voltage which, combined with the rated current of this circuit, determines its application.  
For polyphase circuits, it is stated as the voltage between phases.

**NOTE** *Standard values of rated control circuit voltages are found in the relevant standards for the incorporated devices.*

The manufacturer of the ASSEMBLY shall state the limits of voltage necessary for correct functioning of the main and auxiliary circuits. In any case, these limits must be such that the voltage at the control circuit terminals of incorporated components is maintained under normal load conditions, within the limits specified in the relevant IEC standards.

**4.1.2 Rated insulation voltage ( $U_i$ ) (of a circuit of an ASSEMBLY)**  
The rated insulation voltage ( $U_i$ ) of a circuit of an ASSEMBLY is the voltage value to which dielectric test voltages and creepage distances are referred.  
The maximum rated operational voltage of any circuit of the ASSEMBLY shall not exceed its rated insulation voltage. It is assumed that the operational voltage of any circuit of an ASSEMBLY will not, even temporarily, exceed 110% of its rated insulation voltage.

**NOTE** *For single-phase circuits derived from IT systems (see IEC 364-3), the rated insulation voltage should be at least equal to the voltage between phases of the supply.*

**4.2 Rated current (of a circuit of an ASSEMBLY)**  
The rated current of a circuit of an ASSEMBLY is stated by the manufacturer, taking into consideration the ratings of the components of the electrical equipment within the ASSEMBLY, their disposition and application. This current must be carried without the temperature-rise of its several parts exceeding the limits specified in 7.3 (table 3) when verified according to 8.2.1.

**NOTE** *Due to the complex factors determining the rated currents, no standard values can be given.*

**4.3 Rated short-time withstand current ( $I_{cw}$ ) (of a circuit of an ASSEMBLY)**  
The rated short-time withstand current of a circuit of an ASSEMBLY is the r.m.s. value of short-time current assigned to that circuit by the manufacturer, which that circuit can carry without damage under the test conditions specified in 8.2.3. Unless otherwise stated by the manufacturer, the time is 1 s. (IEV 441-17-17 modified)

For a.c. the value of the current is the r.m.s. value of the a.c. component and it is assumed that the highest peak value likely to occur does not exceed n times this r.m.s. value, the factor n being given in 7.5.3.

**NOTE 1** *If the time is shorter than 1 s, both the rated short-time withstand current and the time should be stated, for example 20 kA, 0.2 s.*

**NOTE 2** *The rated short-time withstand current can be either a prospective current when the tests are conducted at the rated operational voltage or an actual current when the tests are conducted at a lower voltage. This rating is identical to the rated prospective short-circuit current defined in the previous edition of this standard if the test is conducted at the rated maximum operational voltage.*

**4.4 Rated peak withstand current ( $I_{pk}$ ) (of a circuit of an ASSEMBLY)**

The rated peak withstand current of a circuit of an ASSEMBLY is the value of peak current, assigned to that circuit by the manufacturer, which that circuit can withstand satisfactorily under the test conditions specified in 8.2.3. (see also 7.5.3). (IEV 441-17-18 modified).

**4.5 Rated conditional short-circuit current ( $I_{cc}$ ) (of a circuit of an ASSEMBLY)**

The rated conditional short-circuit current of a circuit of an ASSEMBLY is the value of prospective short-circuit current, stated by the manufacturer, which that circuit, protected by a short-circuit protective device specified by the manufacturer, can withstand satisfactorily for the operating time of the device under the test conditions specified in 8.2.3 (see also 7.5.2.).

The details of the specified short-circuit protective device shall be stated by the manufacturer.

**NOTE 1** *For a.c., the rated conditional short-circuit current is expressed by the r.m.s. value of the a.c. component.*

**NOTE 2** *The short-circuit protective device may either form an integral part of the ASSEMBLY or be a separate unit.*

**4.6 Rated fused short-circuit current ( $I_{cf}$ ) (of a circuit of an ASSEMBLY)**

The rated fused short-circuit current of a circuit of an ASSEMBLY is the rated conditional short-circuit current when the short-circuit protective device is a fuse according to IEC 269. (IEV 441-17-21 modified).

**4.7 Rated diversity factor**

The rated diversity factor of an ASSEMBLY or a part of an ASSEMBLY having several main circuits (e.g. a section or sub-section) is the ratio of the maximum sum, at any one time, of the assumed currents of all the main circuits involved, to the sum of the rated currents of all the main circuits of the ASSEMBLY or the selected part of the ASSEMBLY.

When the manufacturer states a rated diversity factor, this factor shall be used for the temperature-rise test in accordance with 8.2.1.

**NOTE** *In the absence of information concerning the actual currents, the following conventional values may be used:*

Table 1

Number of main circuits	Diversity factor
2 and 3	0.9
4 and 5	0.8
6 to 9 inclusive	0.7
10 (and above)	0.6

## 4.1 **Rated voltage**

### 4.1.1 **Rated operational voltage and frequency**

Main circuit 690 V, 50 and 60 Hz.

*On request: Switchgear for AC with other rated operating voltages and frequencies. Switchgear for DC is also available.*

Auxiliary circuit 230 V, 50 and 60 Hz.

*On request: Other rated operating voltages, but max. 500 V AC. DC is also available.*

### 4.1.2 **Rated insulation voltage**

Cubicles and busbars up to 1000 V AC, 1500 V AC and incorporated apparatus according to the ratings of the apparatus and their connections.

### 4.2 – 4.6 **Rated current**

The rated currents of the switchgear's incorporated apparatus are selected according to the information provided by the orderer. The switchgear is supplied with its busbar equipment sized according to the apparatus incorporated, using the diversity factor as laid down in item 4.7 in IEC 439.1, and according to the plant's short-circuit current. The busbar ratings can be obtained from the MNS catalogue.

---

# Service conditions according to IEC 439-1

## 6.1 Normal service conditions

ASSEMBLIES conforming to this standard are intended for use under the following service conditions.

**NOTE** *If components, for example relays, electronic equipment, are used which are not designed for these conditions, appropriate steps should be taken to ensure proper operation (see 7.6.2.4, second paragraph).*

### 6.1.1 Ambient air temperature

#### 6.1.1.1 Ambient air temperature for indoor installations

The ambient air temperature does not exceed +40 °C and its average over a period of 24 h does not exceed +35 °C.

The lower limit of the ambient air temperature is –5 °C.

### 6.1.2 Atmospheric conditions

#### 6.1.2.1 Atmospheric conditions for indoor installations

The air is clean and its relative humidity does not exceed 50 % at a maximum temperature of +40 °C. Higher relative humidities may be permitted at lower temperatures, for example 90 % at +20 °C. Care should be taken of moderate condensation which may occasionally occur due to variations in temperature.

#### 6.1.2.3 Pollution degree

The pollution degree (see 2.9.10) refers to the environmental conditions for which the ASSEMBLY is intended.

For switching devices and components inside an enclosure, the pollution degree of the environmental conditions in the enclosure is applicable.

For the purpose of evaluating clearances and creepage distances, the following four degrees of pollution in the micro-environment are established (clearances and creepage distances according to the different pollution degrees are given in tables 14 and 16):

##### Pollution degree 1:

No pollution or only dry, non-conductive pollution occurs.

##### Pollution degree 2:

Normally, only non-conductive pollution occurs. Occasionally, however, a temporary conductivity caused by condensation may be expected.

##### Pollution degree 3:

Conductive pollution occurs, or dry, non-conductive pollution occurs which becomes conductive due to condensation.

##### Pollution degree 4:

The pollution generates persistent conductivity caused, for instance, by conductive dust or by rain or snow.

##### Standard pollution degree of industrial applications:

Unless otherwise stated, ASSEMBLIES for industrial applications are generally for use in a pollution degree 3 environment. However, other pollution degrees may be considered to apply, depending upon particular applications or the micro-environment.

**NOTE** *The pollution degree of the micro-environment for the equipment may be influenced by installation in an enclosure.*

### 6.1.3 Altitude

The altitude of the site of installation does not exceed 2 000 m (6 600 ft).

**NOTE** *For electronic equipment to be used at altitudes above 1 000 m it may be necessary to take into account the reduction of the dielectric strength and of the cooling effect of the air. Electronic equipment intended to operate in these conditions should be designed or used in accordance with an agreement between manufacturer and user.*

## 6.2 Special service conditions

Where any of the following special service conditions exist, the applicable particular requirements shall be complied with or special agreements shall be made between user and manufacturer. The user shall inform the manufacturer if such exceptional service conditions exist.

Special service conditions are for example:

6.2.1 Values of temperature, relative humidity and/or altitude differing from those specified in 6.1.

6.2.2 Applications where variations in temperature and/or air pressure take place at such a speed that exceptional condensation is liable to occur inside the ASSEMBLY.

6.2.3 Heavy pollution of the air by dust, smoke, corrosive or radioactive particles, vapours or salt.

6.2.4 Exposure to strong electric or magnetic fields.

6.2.5 Exposure to extreme temperatures, for example radiation from sun or furnaces.

6.2.6 Attack by fungus or small creatures.

6.2.7 Installation in locations where fire or explosion hazards exist.

6.2.8 Exposure to heavy vibration and shocks.

6.2.9 Installation in such a manner that the current-carrying capacity or breaking capacity is affected, for example equipment built into machines or recessed into walls.

6.2.10 Consideration of appropriate remedies against conducted and radiated disturbances other than EMC.

Consideration of appropriate remedies against EMC disturbances in environments other than those described in 7.10.1.

## 6.3 Conditions during transport, storage and erection

6.3.1 A special agreement shall be made between user and manufacturer if the conditions during transport, storage and erection, for example, temperature and humidity conditions, differ from those defined in 6.1.

Unless otherwise specified, the following temperature range applies during transport and storage: between –25 °C and +55 °C and, for short periods not exceeding 24 h, up to +70 °C.

Equipment subjected to these extreme temperatures without being operated, shall not undergo any irreversible damage and shall then operate normally in the specified conditions.

6.1 **Normal service conditions**

The switchgear is designed for indoor erection.

6.2 **Special service conditions**

*On request: The switchgear can be adapted to special operating conditions.*

6.3 **Conditions during transport, storage and erection**

For road transport:

Separate cubicles on wooden pallets, encased in transparent plastic sheeting, fastened down with straps.

For sea transport:

Separate cubicles in hermetically sealed plastic covers placed in wooden boxes and with a moisture-absorbing agent in the cubicles.

For air transport:

Separate cubicles in hermetically sealed plastic covers placed in plywood boxes or wooden crates.

For container transport:

Separate cubicles on wooden pallets fastened down with straps. The space between cubicle door to the pallet edges to be filled with corrugated cardboard or foam plastic chips.

---

# Design and construction according to IEC 439-1

## 7.1 Mechanical design

### 7.1.3 Terminals for external conductors

7.1.3.1 The manufacturer shall indicate if the terminals are suitable for connection of copper or aluminium conductors or both. The terminals shall be such that the external conductors may be connected by a means (screws, connectors, etc.) which ensures that the necessary contact pressure corresponding to the current rating and the short-circuit strength of the apparatus and the circuit is maintained.

7.1.3.2 In the absence of a special agreement between manufacturer and user, terminals shall be capable of accommodating conductors and cables of copper from the smallest to the largest cross-sectional areas corresponding to the appropriate rated current (see annex A).

Where aluminium conductors are used, terminals which cater for the maximum sizes of conductors given in column c of table A.1 of annex A are usually dimensionally adequate. In those instances where the use of this maximum size of aluminium conductor prevents the full utilization of the rated current of the circuit, it will be necessary, subject to agreement between manufacturer and user, to provide means of connection for an aluminium conductor of the next larger size.

In the case where external conductors for electronic circuits with low level currents and voltages (less than 1 A and less than 50 V a.c. or 120 V d.c.) have to be connected to an ASSEMBLY, table A.1 of annex A does not apply (see note 2 of table A.1).

7.1.3.3 The available wiring space shall permit proper connection of the external conductors of the indicated material and, in the case of multicore cables, spreading of the cores.

The conductors must not be subjected to stresses which reduce their normal life.

7.1.3.4 Unless otherwise agreed between manufacturer and user, on three-phase and neutral circuit, terminals for the neutral conductor shall allow the connection of copper conductors having a current-carrying capacity:

- equal to half the current-carrying capacity of the phase conductor, with a minimum of 10 mm<sup>2</sup>, if the size of the phase conductor exceeds 10 mm<sup>2</sup>;
- equal to the full current-carrying capacity of the phase conductor if the size of the latter is less than or equal to 10 mm<sup>2</sup>.

**NOTE 1** For conductors other than copper conductors, the above cross-sections should be replaced by cross-sections of equivalent conductivity, which may require larger terminals.

**NOTE 2** For certain applications in which the current in the neutral conductor may reach high values, for example large fluorescent lighting installations, a neutral conductor having the same current-carrying capacity as the phase conductors may be necessary, subject to special agreement between manufacturer and user.

7.1.3.5 If connecting facilities for incoming and outgoing neutral, protective and PEN conductors are provided, they shall be arranged in the vicinity of the associated phase conductor terminals.

7.1.3.6 Openings in cable entries, cover plates, etc., shall be so designed that when the cables are properly installed, the stated protective measures against contact and degree of protection shall be obtained. This implies the selection of means of entry suitable for the application as stated by the manufacturer.

## 7.2 Enclosure and degree of protection

### 7.2.1 Degree of protection

7.2.1.1 The degree of protection provided by any ASSEMBLY against contact with live parts, ingress of solid foreign bodies and liquid is indicated by the designation IP... according to IEC 529.

For ASSEMBLIES for indoor use where there is no requirement for protection against ingress of water, the following IP references are preferred:

IP00, IP2X, IP3X, IP4X, IP5X

Where some degree of protection against ingress of water is required, the following table gives the preferred IP numbers.

Table 2 List of preferred IP numbers

First characteristic numeral	Second characteristic numeral				
	1	2	3	4	5
Protection against contact and protection against ingress of solid foreign bodies	Protection against harmful ingress of water				
2	IP21				
3	IP31	IP32			
4		IP42	IP43		
5			IP53	IP54	IP55
6				IP64	IP65

## 7.3 Temperature rise

The temperature rise limits given in Table 3 shall not be exceeded for ASSEMBLIES when verified in accordance with 8.2.1.

**NOTE** The temperature rise of an element or part is the difference between the temperature of this element or part measured in accordance with 8.2.1.5 and the ambient air temperature outside the ASSEMBLY.

(Extract from Table 3) Temperature rise limits

Parts of ASSEMBLIES	Temperature rise (K)
Terminals for external insulated conductors	70
Busbars and conductors, plug-in contacts of removable or withdrawable parts which connect to busbars	Limited by: <ul style="list-style-type: none"> <li>- mechanical strength of conducting material;</li> <li>- possible effect on adjacent equipment;</li> <li>- permissible temperature limit of the insulating materials in contact with the conductor;</li> <li>- the effect of the temperature of the conductor on the apparatus connected to it;</li> <li>- for plug-in contacts, nature and surface treatment of the contact material</li> </ul>
Manual operating means: <ul style="list-style-type: none"> <li>- of metal</li> <li>- of insulating material</li> </ul>	15 <sup>1)</sup> 25 <sup>1)</sup>
Accessible external enclosures and covers: <ul style="list-style-type: none"> <li>- metal surfaces</li> <li>- insulating surfaces</li> </ul>	30 <sup>2)</sup> 40 <sup>2)</sup>

<sup>1)</sup> Refers to operating devices accessible from the outside of an ASSEMBLY with closed doors.

<sup>2)</sup> Unless otherwise specified in the case of covers and enclosures which are accessible but need not be touched during normal operation, an increase in the temperature-rise limits by 10 K is permissible.

## 7.1

### 7.1.3 Terminals for external conductors

#### **Circuit-breaker cubicle and disconnecter cubicle; cable connection from below**

Main circuits: Connection bars with pre-drilled holes  $d = 14$ .

Auxiliary circuits: Connected to terminal board rows with screwed clamps.

#### **Circuit-breaker cubicle and disconnecter cubicle; connection from above**

Main circuits: Connection bars through roof with pre-drilled holes for bars.

Auxiliary circuits: Connected to terminal board row with screwed clamps.

#### **Apparatus units, W design**

Main circuits:

Size 4M/4	Connected to terminal board row, cable cross-sectional area max. $10 \text{ mm}^2$
Size 2M	Connection device with screwed clamps for cable cross-sectional area max. $25 \text{ mm}^2$
Size 4 - 12M	Connection device with threaded holes for cable lug connection of max. $1 \times 120 \text{ mm}^2$ cable cross-sectional area for 160 A device max. $2 \times 240 \text{ mm}^2$ cable cross-sectional area for 400 A device
Size 8 - 12M	Connection device with threaded holes for cable lug connection of max. $4 \times 240 \text{ mm}^2$ cable cross-sectional area for 800 A device.

Auxiliary circuits: Connected to terminal board with screwed clamps, max.  $1 \times 2.5 \text{ mm}^2$ .

#### **Apparatus units, R design**

Main circuits: Connected directly to the apparatus terminals with cable lugs or clamps.

Auxiliary circuits: Connected to 10-pole terminal board devices with screwed clamps max.  $1 \times 4 \text{ mm}^2$ .

### 7.1.3.5 Connection of neutral and protective conductors

Pre-drilled neutral bar, holes  $d = 8 \text{ mm}$  separated by  $50 \text{ mm}$ .

*On request: Auxiliary earth bar with 15 terminals for  $10 \text{ mm}^2$  copper conductors.*

*On request: Earth bar for the screening of the signal cables.*

### 7.1.3.6 Laying of external cables in separate cable compartments for main and auxiliary current paths

From below: Four cable fixing iron pieces on the right-hand side and rear are supplied.

Where the degree of protection so demands, base-plates are also supplied with two openings and cover plates intended for hole drilling when inserting cables.

*On request: Connection from above (roof plates for apparatus cubicles are provided with flange openings FL21).*

## 7.2 Enclosure and degree of protection

### 7.2.1 Degree of protection

The switchgear has degree of protection IP31. Also see 7.4.6.1, 7.4.6.2 and 7.6.4.3.

*On request: Other degree of protection up to IP54.*

## 7.3 Temperature rise

An 85 degree temperature rise in horizontal and vertical busbars.

*On request: Lower temperature rise.*

---

# Protection against electric shock according to IEC 439-1

## 7.4.2 Protection against direct contact (see 2.6.8.)

Protection against direct contact can be obtained either by appropriate constructional measures on the ASSEMBLY itself or by additional measures to be taken during installation; this may require information given by the manufacturer.

An example of additional measures to be taken is the installation of an open-type ASSEMBLY without further provisions in a location where access is only permitted for authorized personnel.

## 7.4.3 Protection against indirect contact (see 2.6.9)

The user shall indicate the protective measure which is applied to the installation for which the ASSEMBLY is intended. In particular, attention is drawn to IEC 364-4-41, where requirements for protection against indirect contact are specified for the complete installation, for example the use of protective conductors.

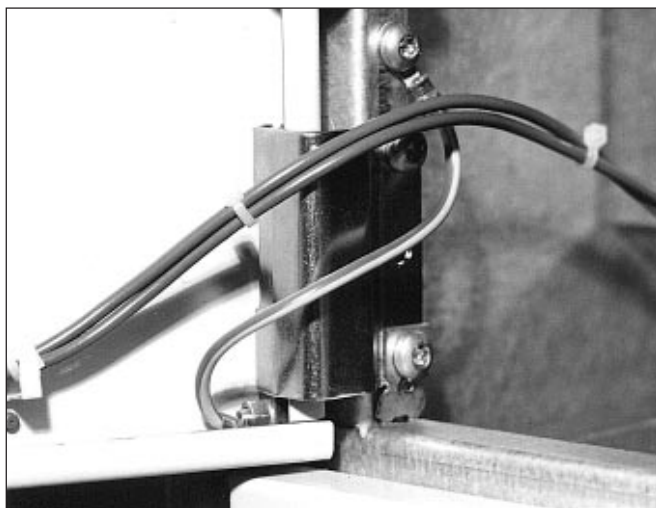

*Open door with protective conductor between door and frame.*

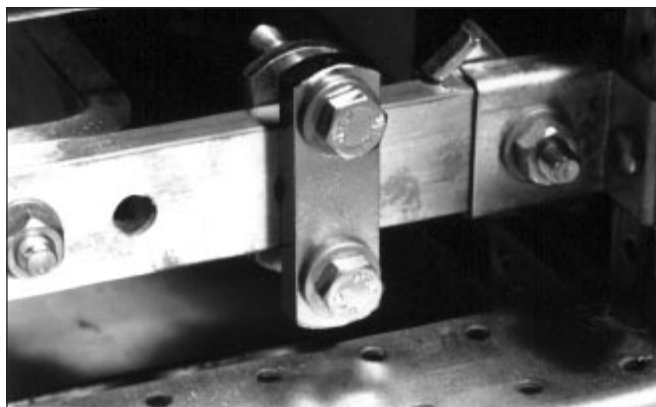

*Extra clamp for connection of earth line in circuit-breaker cubicle.*

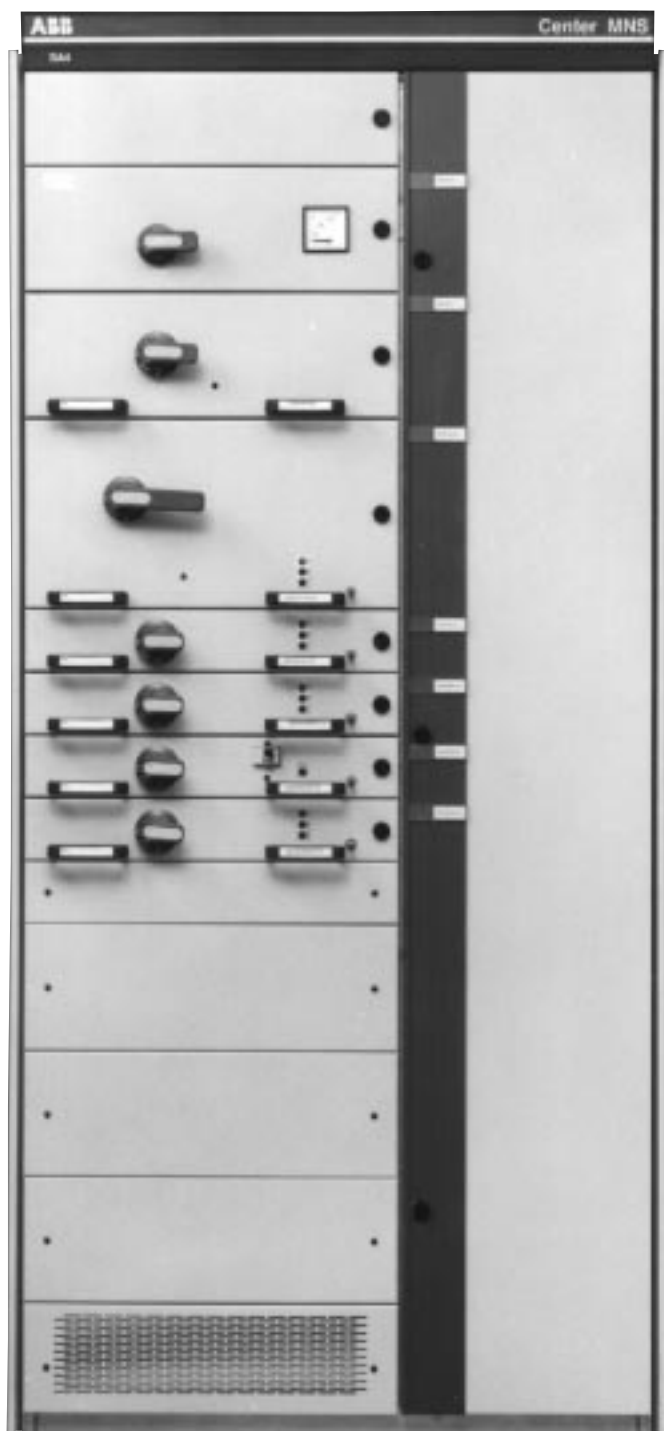

*Switchgear with normal locks on doors.*

### 7.4.2 **Protection against direct contact**

The switchgear is designed for erection in an switchgear room where only specially authorized personnel are allowed in. Tools are required to open doors.

*On request: Keylock.*

### 7.4.3 **Protective measures against indirect contact**

The switchgear is protected against dangerous voltages in the event of faults involving protective current paths in contact with the protective conductor bar at the bottom of the cubicle. Upon installation, this protective conductor bar is to be connected together with other cubicles and external protective conductors. Doors fitted with equipment are earthed to the cubicle frame or the unit by means of a copper conductor.

---

# Requirements related to accessibility for inspection according to IEC 439-1

7.4.6 Requirements related to accessibility in service by authorized personnel  
For accessibility in service by authorized personnel, as agreed between manufacturer and user, one or more of the following requirements shall be fulfilled subject to agreement between manufacturer and user. These requirements shall be complementary to the protective measures specified in 7.4.

**NOTE** *This implies that the agreed requirements shall be valid when an authorized person can obtain access to the ASSEMBLY, for example by the use of tools or by overriding an interlock (see 7.4.2.2.3) when the ASSEMBLY or part of it is under voltage.*

7.4.6.1 Requirements related to accessibility for inspection and similar operations  
The ASSEMBLY shall be designed and arranged in such a way that certain operations, according to agreement between manufacturer and user, can be performed when the ASSEMBLY is in service and under voltage. Such operations may be:

- visual inspection of:
  - switching devices and other apparatus,
  - settings and indicators of relays and releases,
  - conductor connections and marking;
- adjusting and resetting of relays, releases and electronic devices;
- replacement of fuse-links;
- replacement of indicating lamps;
- certain fault location operations, for example voltage and current measuring with suitably designed and insulated devices.

7.4.6.2 Requirements related to accessibility for maintenance  
To enable maintenance agreed upon between manufacturer and user on a disconnected functional unit or group of the ASSEMBLY, with adjacent functional units or groups still under voltage, necessary measures shall be taken. The choice, which is subject to agreement between manufacturer and user, depends on such factors as service conditions, frequency of maintenance, competence of the authorized personnel, local installation rules, etc.

- Such measures may be:
- sufficient space between the actual functional unit or group and adjacent functional units or groups. It is recommended that parts likely to be removed for maintenance have as far as possible retainable fastening means;
  - use of barrier-protected sub-sections for each functional unit or group;
  - use of compartments for each functional unit or group;
  - insertion of additional protective means provided or specified by the manufacturer.

7.4.6.3 Requirements related to accessibility for extension under voltage

When it is required to enable future extension of the ASSEMBLY with additional functional units or groups, with the rest of the ASSEMBLY still under voltage, the requirements specified in 7.4.6.2 apply, subject to agreement between manufacturer and user. These requirements also apply for the insertion and connection of additional outgoing cables when the existing cables are under voltage.

The connection of additional units to their incoming supply shall not be made under voltage, unless the design of the ASSEMBLY permits such connections.



Upon request, a resetting button for a thermal relay can be placed on the door.



The unit handle can be locked with up to three padlocks.



Door deblocking is done with the help of a screwdriver or similar.

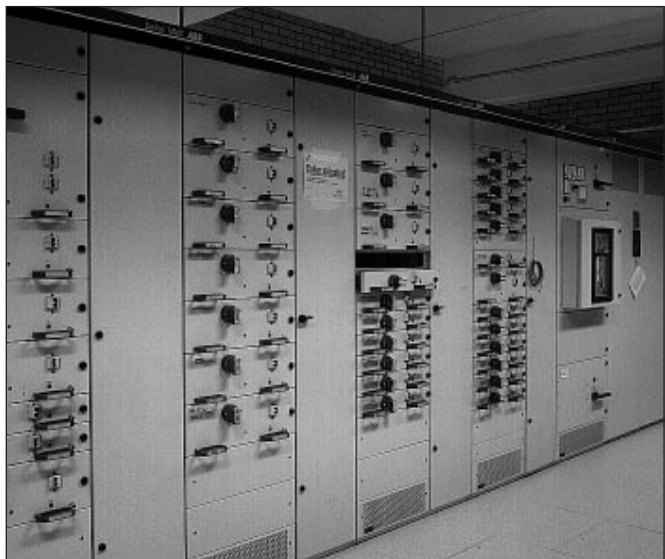

Possibilities for extension.

## 7.4.6.1 Requirements related to accessibility for inspection and similar operations

### **Door interlocking**

The door in front of each functional unit can only be opened when the unit circuit-breaker is tripped.

### **Door deblocking using a screwdriver**

The door interlock can be deblocked using a screwdriver. The door can then be opened with the outgoing branch under voltage or when in service.

### **Degree of protection with open door**

Inside the cubicle front, circuit-breaker off: IP20.

Inside the cubicle front, door deblocked: IP00.

On the door in front of the outgoing branch: IP20.

In cable cubicles: IP20 for W units, IP00 for R units.

### **Apparatus**

The setting range for the thermal relay is set using a screwdriver.

The setting screw on the thermal relay is accessible with door open from the front of the switchgear.

The resetting button on the thermal relay is accessible with door open from the front of the switchgear.

For replacing knife-blade fuse cartridges in the main circuit, insulated screened cartridge insertion and removal devices are used in accordance with SEN 28 05 05.

*Upon request: Electric remote resetting of thermal relay. For local resetting, the resetting button is available placed on the door.*

## 7.4.6.2 Requirements related to accessibility for maintenance

### **Replacement under voltage**

Removable and withdrawable units can be replaced under voltage.

### **Protective screening**

Only the outgoing branch concerned need be laid free since each unit has an individual door.

There are protective screens between the outgoing branches.

The incoming supply to the first apparatus in the outgoing branch is screened.

The cubicle busbars are screened.

Apparatus cubicles and separate cable compartments are screened against horizontal busbars. There are rubber shrouds for cable connections in separate cable compartments.

### **Door interlocking**

The door in front of each functional unit can only be opened when the unit circuit-breaker is tripped.

### **Degree of protection with open door**

Inside the cubicle front, circuit-breaker off: IP20.

On the door in front of the outgoing branch: IP20.

Cubicle busbars (also applies when the unit is taken out): IP20.

Incoming supply to the first apparatus: IP20.

When a unit is removed, against adjacent live parts: IP20.

In cable cubicles: IP20 for W units, IP00 for R units.

## 7.4.6.3 Requirements related to accessibility for extension under voltage

Switchgear assemblies of standard design are not intended for extension under voltage.

Cubicles for W and R designs can be extended with further outgoing branches under voltage, provided that the connections on other outgoing branches in separate cable compartments are protectively screened and space has been reserved.

---

# Short-circuit protection and short-circuit withstand strength according to IEC 439-1

- 7.5.2 Information concerning the short-circuit withstand strength
- 7.5.2.3 For an ASSEMBLY having several incoming units which are likely to be in operation simultaneously, and for an ASSEMBLY having one incoming unit and one or more outgoing units for high-power rotating machines likely to contribute to the short-circuit current, a special agreement shall be made to determine the values of prospective short-circuit current in each incoming unit, in each outgoing unit and in the busbars.
- 7.5.4 Co-ordination of short-circuit protective devices
- 7.5.4.1 The co-ordination of protective devices shall be the subject of an agreement between manufacturer and user. Information given in the manufacturer's catalogue may take the place of such an agreement.
- 7.5.4.2 If the operating conditions require maximum continuity of supply, the settings or selection of the short-circuit protective devices within the ASSEMBLY should, where possible, be so graded that a short-circuit occurring in any outgoing branch circuit is cleared by the switching device installed in the faulted branch circuit without affecting the other outgoing branch circuits, thus ensuring selectivity of the protective system.

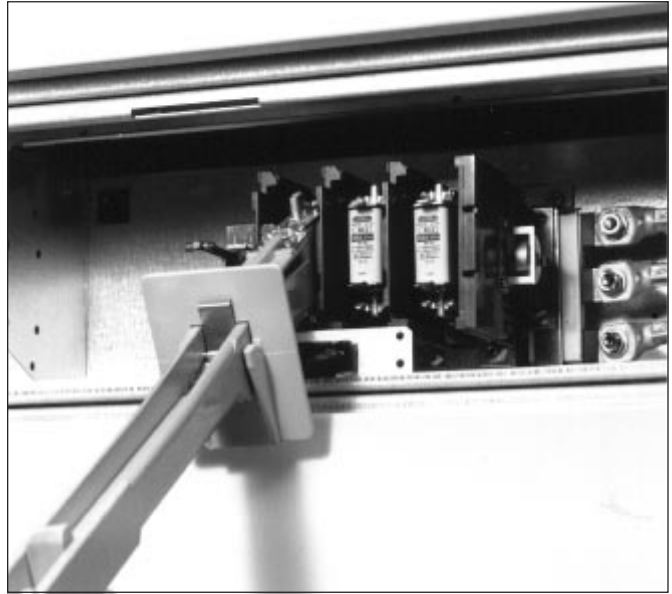

*Replacing of fuses in units  $\geq 4M$  takes place from the front using a cartridge insertion and removal device in accordance with SEN 28 05 05.*



*Replacing of fuses in 2M units takes place with the unit removed from the cubicle.*

**7.5.2 Information concerning the short-circuit withstand strength**

See under rated data in the catalogue.

**7.5.4 Co-ordination of short-circuit protective devices**

Switchgear assemblies of standard design with a circuit-breaker in the incoming supply unit, cubicle fuse and fuse in the outgoing branches are selective, i.e., a short circuit in the unit trips the unit's short-circuit protection before the cubicle fuse and the circuit-breaker.

Information on the tripping curves of the fuses and the circuit-breaker can be obtained from catalogues.

---

## Parts included in assembly according to IEC 439-1

---

### 7.6.4.2 Interlocking and padlocking of withdrawable parts

Unless otherwise specified, withdrawable parts shall be fitted with a device which ensures that the apparatus can only be withdrawn and/or re-inserted after its main circuit has been interrupted.

In order to prevent unauthorized operation, withdrawable parts may be provided with means for a padlock or lock to secure them in one or more of their positions (see 7.1.1).

### 7.6.4.3 Degree of protection

The degree of protection (see 7.2.1.) indicated for ASSEMBLIES normally applies to the connected position (see 2.2.9) of the removable and/or withdrawable parts. The manufacturer shall indicate the degree of protection obtained in the other positions and during the transfer between positions.

ASSEMBLIES with withdrawable parts may be so designed that the degree of protection applying to the connected position is also maintained in the test and disconnected positions and during transfer from one position to another.

If, after the removal of a removable and/or withdrawable part, the original degree of protection is not maintained, an agreement shall be reached as to what measures shall be taken to ensure adequate protection. Information given in the manufacturer's catalogue may take the place of such an agreement.

## 7.6.4.2 Interlocking and padlocking of withdrawable parts

The unit is interlocked so that it cannot be moved between different positions until the unit circuit-breaker is tripped and thus its main current path has been opened.

The unit is blocked against transfer in the Connected and Disconnected positions.

The unit can be locked using a padlock in the Connected and Disconnected positions when the unit handle is in the 'O' or test position.

The ACB circuit-breaker is interlocked so as not be moved between different positions until it is switched off and consequently its main circuits is open. The circuit-breaker is blocked against transfer in Connected, Test and Disconnected position.

## 7.6.4.3 Degree of protection

### Units:

Connected position: IP31.

Disconnected position: IP20.

Transfer between different positions: IP20.

Unit removed while adjacent units of W design are in service or under voltage: IP20.

Unit removed while adjacent units of R design are in service or under voltage: IP00.

Cover panel mounted on post: IP20.

To retain the original degree of protection when a unit is removed, a cover panel shall be mounted.

*On request: Extra cover panels with fixing brackets.*

### Air circuit-breaker:

Connected position: IP21.

Test position: IP20.

Disconnected position: IP20.

Transfer between different positions: IP20.

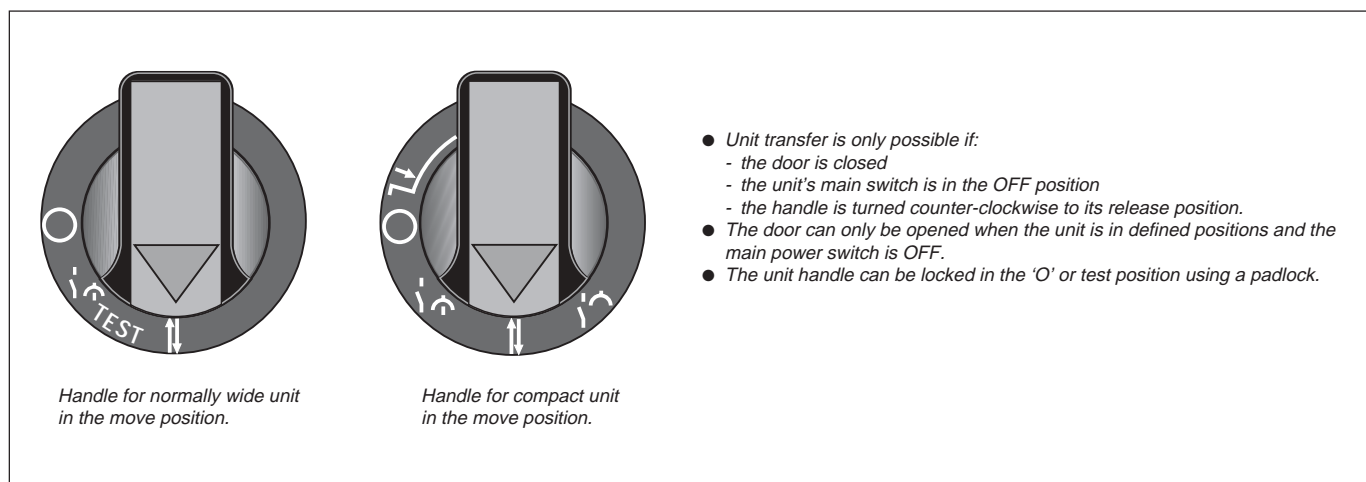

# Internal separation of assemblies by barriers and partitions according to IEC 439-1

7.7 One or more of the following conditions can be obtained by dividing ASSEMBLIES by means of partitions or barriers (metallic or non-metallic) into separate compartments or enclosed protected spaces:

- protection against contact with hazardous parts belonging to the adjacent functional units. The degree of protection shall be at least IPXXB;
- protection against the passage of solid foreign bodies from one unit of an ASSEMBLY to an adjacent unit. The degree of protection shall be at least IP2X.

Unless otherwise stated by the manufacturer, both conditions shall apply.

**NOTE** *The degree of protection IP2X covers the degree of protection IPXXB.*

The following are typical forms of separation by barriers or partitions (for examples, see annex D).

Main criteria	Subcriteria	Form
No separation		Form 1
Separation of busbars from the functional units	Terminals for external conductors not separated from busbars	Form 2a
	Terminals for external conductors separated from busbars	Form 2b
Separation of busbars from the functional units and separation of all functional units from one another. Separation of the terminals for external conductors from the functional units, but not from each other.	Terminals for external conductors not separated from busbars	Form 3a
	Terminals for external conductors separated from busbars	Form 3b
Separation of busbars from the functional units and separation of all functional units from one another, including the terminals for external conductors which are an integral part of the functional unit.	Terminals for external conductors in the same compartment as the associated functional unit	Form 4a
	Terminals for external conductors not in the same compartment as the associated functional unit, but in individual, separate, enclosed protected spaces or compartments	Form 4b

The form of separation and higher degrees of protection shall be the subject of an agreement between manufacturer and user.

See 7.4.2.2.2 with regard to stability and durability of barriers and partitions.

See 7.4.6.2 with regard to accessibility for maintenance on disconnected functional units.

See 7.4.6.3 with regard to accessibility for extension under voltage.

## 7.7 Form classes regarding internal separation

ACB cubicles	4a
Disconnecter cubicles	4a
Removeable units	4a
Withdrawable units	4b
Group boards	4a
SlimLine units	4a

Apart from using protective screening, the risk of causing injurious arcs can be limited by including an insulated, vertical busbar system in the apparatus cubicles.

---

# Requirements for electronic equipment supply circuits according to IEC 439-1

---

Unless otherwise specified in the relevant IEC specifications for electronic equipment, the following requirements apply:

- 7.9.1 Input voltage variations
- 1) Supply voltage range for battery sources equal to the rated supply voltage  $\pm 15\%$ .  
*Note – This range does not include the additional voltage range required for charging batteries.*
  - 2) Range of the input direct voltage which is obtained by rectification of the alternating supply voltage, see item 3.
  - 3) Supply voltage range for a.c. sources equal to the rated input voltage  $\pm 10\%$ .
  - 4) If a wider tolerance is necessary this is subjected to agreement between manufacturer and user.
- 7.9.4 Temporary variations in voltage and frequency
- The equipment shall operate without damage when there are temporary variations in the following conditions:
- a) Voltage drops not exceeding 15 % of rated voltage for periods not longer than 0.5 s.
  - b) Supply frequency deviation of up to  $\pm 1\%$  of rated frequency. If a wider tolerance is necessary, this is subject to agreement between manufacturer and user.
  - c) The maximum admissible duration of an interruption of the supply voltage for equipment shall be indicated by the manufacturer.

## Electromagnetic compatibility (EMC) according to IEC 439-1

---

- 7.10.1 EMC environment
- Unless subject to special agreement (see section 6.2.10), ASSEMBLIES conforming to this standard are intended for use in environmental condition Environment 1 and/or Environment 2 as described below.
- Environment 1  
Mainly relates to low-voltage public network such as residential, commercial and light-industrial locations/installations, as per clause 5 of EN 50081-1.
- NOTE** *The following list, although not comprehensive, gives an indication of locations which are included.*
- residential properties, e.g. houses, apartments;
  - retail outlets, e.g. shops, supermarkets;
  - business premises, e.g. offices, banks
  - areas of public entertainment, e.g. cinemas, public bars, dance halls;
  - outdoor locations, e.g. petrol stations, car parks, sport centres;
  - light-industrial locations, e.g. workshops, laboratories, service centres.
- Environment 2  
Mainly relates to low-voltage non-public or industrial networks/locations/installations, as per clause 5 of EN 50081-2.
- NOTE** *Industrial locations are characterized by one or more of the following conditions:*
- industrial, scientific and medical apparatus, e.g. working machines are present;
  - heavy inductive or capacitive loads are frequently switched;
  - currents and associated magnetic fields are high.
- The environmental condition 1 or 2 shall be stated in the manufacturer's documentation

- 7.9.1 **Input voltage variations**  
Voltage ranges stated in IEC 439-1 apply.
- 7.9.4 **Temporary variations in voltage and frequency**  
Voltage and frequency ranges stated in IEC 439-1 apply.  
The longest permissible interruption in the supply voltage is zero.
- 

- 7.10.1 **EMC environment**  
Environment class 1 or 2 according to what is agreed in the completed form  
'Confirmation of requirements according to EN 60 439-1, annex E'  
(article no. of form: 1TSC241-EN).  
*Upon request: Other design.*
-

## Type test according to IEC 439-1

- 8.2.1 Verification of temperature-rise limits
- 8.2.1.3.4 For values of test current higher than 3 150 A  
Agreement shall be reached between manufacturer and user on all relevant items of the test, such as: type of supply, number of phases and frequency (where applicable), cross-sections of test conductors, etc. This information shall form part of the test report.
- 8.2.1.6 Ambient air temperature  
The ambient air temperature shall be measured during the last quarter of the test period by means of at least two thermometers or thermocouples equally distributed around the ASSEMBLY at about half its height and at a distance of about 1 m from the ASSEMBLY. The thermometers or thermocouples shall be protected against air currents and heat radiations.  
If the ambient temperature during the test is between +10 °C and +40 °C, the values of table 3, are the limiting values of temperature rise.  
If the ambient air temperature during the test exceeds +40 °C or is lower than +10 °C, this standard does not apply and the manufacturer and the user shall make a special agreement.
- 8.2.3.2.3 Testing of the main circuits  
For ASSEMBLIES with busbars, the tests according to items a), b) and d) below apply.  
For ASSEMBLIES without busbars, the test according to item a) applies.  
For ASSEMBLIES where the requirements of 7.5.5.1.2 are not fulfilled, in addition the test according to item c) applies.
- a) Where an outgoing circuit includes a component which has not previously been subjected to the appropriate test, the following test shall apply:  
For testing an outgoing circuit, the associated outgoing terminals shall be provided with a bolted short-circuit connection. When the protective device in the outgoing circuit is a circuit-breaker, the test circuit may include a shunting resistor in accordance with 8.3.4.1.2 b) of 947-1 in parallel with the reactor used to adjust the short-circuit current.

For circuit-breakers having a rated current up to and including 630 A, a cable of 0.75 m in length having a cross-sectional area corresponding to the conventional thermal current (see IEC 947-1, tables 9 and 10) shall be included in the test circuit. The switching device shall be closed and held closed in the manner normally used in service. The test voltage shall then be applied once and for a time sufficiently long to enable the short-circuit protective device in the outgoing unit to operate to clear the fault, and, in any case, for not less than 10 cycles (test voltage duration).

- b) ASSEMBLIES containing main busbars shall be subjected to one additional test to prove the short-circuit withstand strength of the main busbars and the incoming circuit including any joints. The point where the short-circuit is produced shall be 2 m  $\pm$  0.40 m distant from the nearest point of supply. For the verification of rated short time withstand current (see 4.3) and rated peak withstand current (see 4.4), this distance may be increased if the tests are conducted at lower voltage providing the test current is the rated value (see item b) of 8.2.3.2.4). Where the design of the ASSEMBLY is such that the length of the busbars to be tested is less than 1.6 m and the ASSEMBLY is not intended to be extended, then the complete length of busbar shall be tested, the short-circuit being established at the end of these busbars. If a set of busbars consists of different sections (as regards cross-sections, distance between adjacent busbars, type and number of supports per metre), each section shall be tested separately. The test may be conducted concurrently, provided that the above conditions are met.
- c) A short-circuit is obtained by bolted connections on the conductors connecting the busbars to a single outgoing unit, as near as practicable to the terminals on the busbar side of the outgoing unit. The value of the short-circuit current shall be the same as that for the main bars.
- d) If a neutral bar exists, it shall be subjected to one test to prove its short-circuit withstand strength in relation to the nearest phase busbar including any joints. For the connection of the neutral bar to this phase busbar, the requirements of item b) of 8.2.3.2.3 apply. Unless otherwise agreed between manufacturer and user, the value of the test current in the neutral bar shall be 60 % of the phase current during the three-phase test.

## Routine test according to IEC 439-1

- 8.3.1 Inspection of the ASSEMBLY including inspection of wiring and, if necessary, electrical operation test.  
The effectiveness of mechanical actuating elements, interlocks, locks, etc., shall be checked. The conductors and cables shall be checked for proper laying and the devices for proper mounting. A visual inspection is also necessary to ensure that the prescribed degree of protection, creepage and clearance distances are maintained. The connections, especially the screwed connections, shall be checked for adequate contact, possibly by random tests.  
Further it shall be verified that the information and markings specified in 5.1 and 5.2 are complete, and that the ASSEMBLY corresponds to these. In addition, the conformity of the ASSEMBLY to the circuit and wiring diagrams, technical data, etc., provided by the manufacturer shall be checked.  
Depending on the complexity of the ASSEMBLY, it may be necessary to inspect the wiring and to carry out an electrical functioning test. The test procedure and the number of tests depend on whether or not the ASSEMBLY includes complicated interlocks, sequence control facilities, etc.  
In some cases, it may be necessary to make or repeat this test on site when putting the installation for which the ASSEMBLY is intended into operation. In this case, a special agreement shall be made between manufacturer and user.



Testing of function.

**8.2.1.3.4 Temperature-rise test for values of test current higher than 3150 A**

According to SECRC/G/LR-96/001.

**8.2.1.6 Ambient air temperature during temperature-rise test**

According to SECRC/G/LR-96/001.

**8.2.3.2.3 Value of test current in the neutral bar at short-circuit withstand test**

According to GLBZ 000 075/KEMA 620-85.

---

8.3 Before delivery the cubicles have been checked according to all items under section 8.3 in IEC 439-1, including electrical operation test and conformity with circuit diagram.

8.3.1 *Upon request: Repetition of electrical operation test on site.*

---

It shall be possible to identify the functional units and apparatus of the switchgear assembly. To attain this, identification labels shall be affixed to cubicles, units and apparatus.

**Labels on cubicles**

There shall be a cubicle label at the top of the cubicle stating the cubicle no. (e.g. SA.1).

*Upon request: Another text can be used.*

*Upon request: Identification of the apparatus units can be done on the cable cubicle door using text provided.*



**Labels on unit (G unit)**

A label stating the G unit's item designation (e.g. G1).

The cubicles are divided up into height modules of 50 mm. The digital designation indicates at which height module the G unit is placed, starting from the top and giving the number of the first module seat that the G unit occupies.

When G units are placed side by side, the digital designation consists of 1 - 2 digits + 1 letter. The digits show the G unit's height location. The letter shows the G unit's sequence from the left.

*Upon request: Another text can be used.*

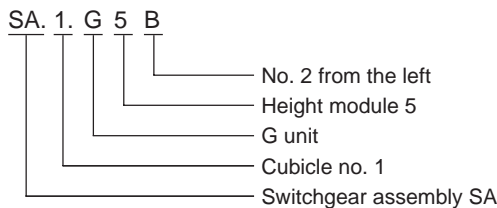
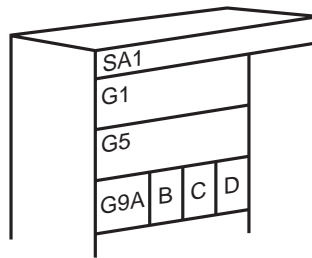

Item designation	Functional unit, apparatus
Q	Circuit-breaker, disconnecter, MCCB, switch, fuse-switch
F	Main fuse, service fuse, miniature circuit-breaker, fuse other than main fuse or service fuse, thermal overload relay, overcurrent relay
X	Neutral terminal, terminal blocks
K	Main contactor, auxiliary contactor, auxiliary relay, time-lag device, time-lag relay
T	Current transformer for thermal overload relay, current transformer for overcurrent, current transformer for measuring, measuring voltage transformer, frame transformer, operating voltage transformer, power transformer
R	Resistor, thermistor
S	Control switch
H	Indications, lamps
P	Measurements: voltage, current, power, energy, operating time
U	Rectifier, current measuring unit, transducer, converter
C	Capacitor device
B	Detector
E	Cubicle lighting, heating element, amplifier, arc monitor
Y	Motor operating device
M	Motor
N	Analogue/digital device

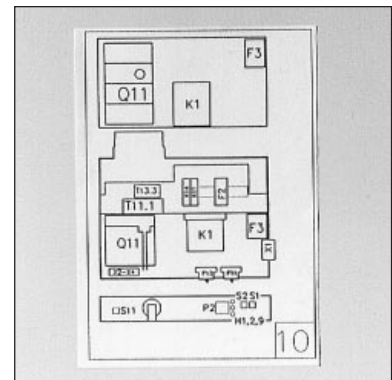

Label showing item designation of the apparatus.

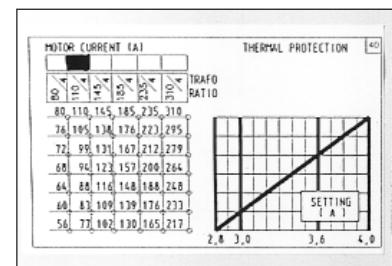

Label showing current transformer ratio where this occurs.

---

**Phase marking of horizontal busbars**

No marking is made. The phases are identified from their positions.

L1, L2, L3 are located from left to right - from top to bottom - from front to rear.

*Upon request: Marking can be carried out at the places specified.*

---

## Documentation

## MNS normal design

---

Upon delivery of a switchgear assembly, documentation verifying what is being delivered is sent separately to the customer. An installation, handling and operation instruction for the switchgear accompany the switchgear.

**Separately forwarded documentation comprises:**

Completed form 1TSC241-EN 'Confirmation of requirements according to EN 60 439-1, annex E' (see Example 1)

Single-line diagram (see Example 2)

Block diagram (see Example 3)

Circuit diagram (see Example 4)

Front layout (see Example 5)

List of apparatus (see Example 6)

List of labels (see Example 7)

Instruction for installation, handling and operation

Instructions, if any, for apparatus

---

# Examples of separately forwarded documentation

## Example 1: Form 1TSC241-EN 'Confirmation of requirements according to EN 60 439-1, annex E'

We reserve all rights in this document and in the information contained therein. Reproduction, use or disclosure to third parties without express authority is strictly forbidden. © ABB 1994

### Confirmation of requirements according to EN 60 439-1 annex E

Confirmation of basic requirements when standard EN 60 439-1 refers to agreement between manufacturer and user. The sections below refer to corresponding section in the standard. Fill in appropriate alternative for each section below.

Section in the standard		Normal design	Other design agreed on
4.7	Rated diversity factor	<input type="checkbox"/>	
6.1.1.2	(Note) Use of assemblies in an arctic climate	<sup>1)</sup>	
6.1.3	(Note) Use of electronic equipment at altitudes above 1000 m	<input type="checkbox"/>	
6.2	Special service conditions	<input type="checkbox"/>	
6.2.10	Electrical and radiated interferences	<input type="checkbox"/>	
6.3.1	Conditions during transport, storage and erection	<input type="checkbox"/>	
7.1.3	Terminals for external conductors	<input type="checkbox"/>	
7.2.1.1	Degree of protection considering intended installation, also against the floor	<input type="checkbox"/>	
7.3	Temperature rise allowed for horizontal busbar system	<input type="checkbox"/>	
7.4.2	Choice of protective measure against direct contact	<input type="checkbox"/>	
7.4.3	Choice of protective measure against indirect contact	<input type="checkbox"/>	
7.4.6	Accessibility in service by authorized personnel	<input type="checkbox"/>	
7.4.6.1	Accessibility for inspection and similar operations	<input type="checkbox"/>	
7.4.6.2	Accessibility for maintenance	<input type="checkbox"/>	
7.4.6.3	Accessibility for extension under voltage	<input type="checkbox"/>	
7.5.2.3	Values of prospective short-circuit current for an assembly in case of several incoming or outgoing units for high-power rotating machines	<input type="checkbox"/>	
7.5.4	Co-ordination of short-circuit protective devices	<input type="checkbox"/>	
7.6.4.3	Degree of protection after removal of removable or withdrawable part	<input type="checkbox"/>	
7.7	Form of internal separation	<input type="checkbox"/>	
7.9.1	Input voltage variations for electronic equipment supply	<input type="checkbox"/>	
7.9.4 item b)	Supply frequency deviation	<input type="checkbox"/>	
7.10.1	Environment 1 (Public network) considering EMC <sup>2)</sup>	<input type="checkbox"/>	
	alt. environment 2 (Industrial network) considering EMC <sup>2)</sup>	<input type="checkbox"/>	
8.2.1.3.4	Temperature-rise test for values of test current higher than 3150 A	<input type="checkbox"/>	
8.2.1.6	Ambient air temperature during temperature-rise test	<input type="checkbox"/>	
8.2.3.2.3 item d)	Value of test current in the neutral bar at short-circuit withstand test	<input type="checkbox"/>	
8.3.1	Repetition of electric operation test on site	<input type="checkbox"/>	
Documentation	Customer documentation: Extent and form	<input type="checkbox"/>	
Labels	Labels on cubicles	<input type="checkbox"/>	
	Labels on apparatus units	<input type="checkbox"/>	
	Phase marking of horizontal busbars	<input type="checkbox"/>	

<sup>1)</sup> Only applicable for outdoor installations      <sup>2)</sup> Only one of the alternatives to be chosen

1TSC241-EN

				Issued by	Dept	Year	Week	Quotation No	Cont
									—
Rev Ind	Revision	Appd	Year	Week	<b>ABB</b>			Order No	<b>1</b>
					ABB Installation				





Example 4.3: Circuit diagram

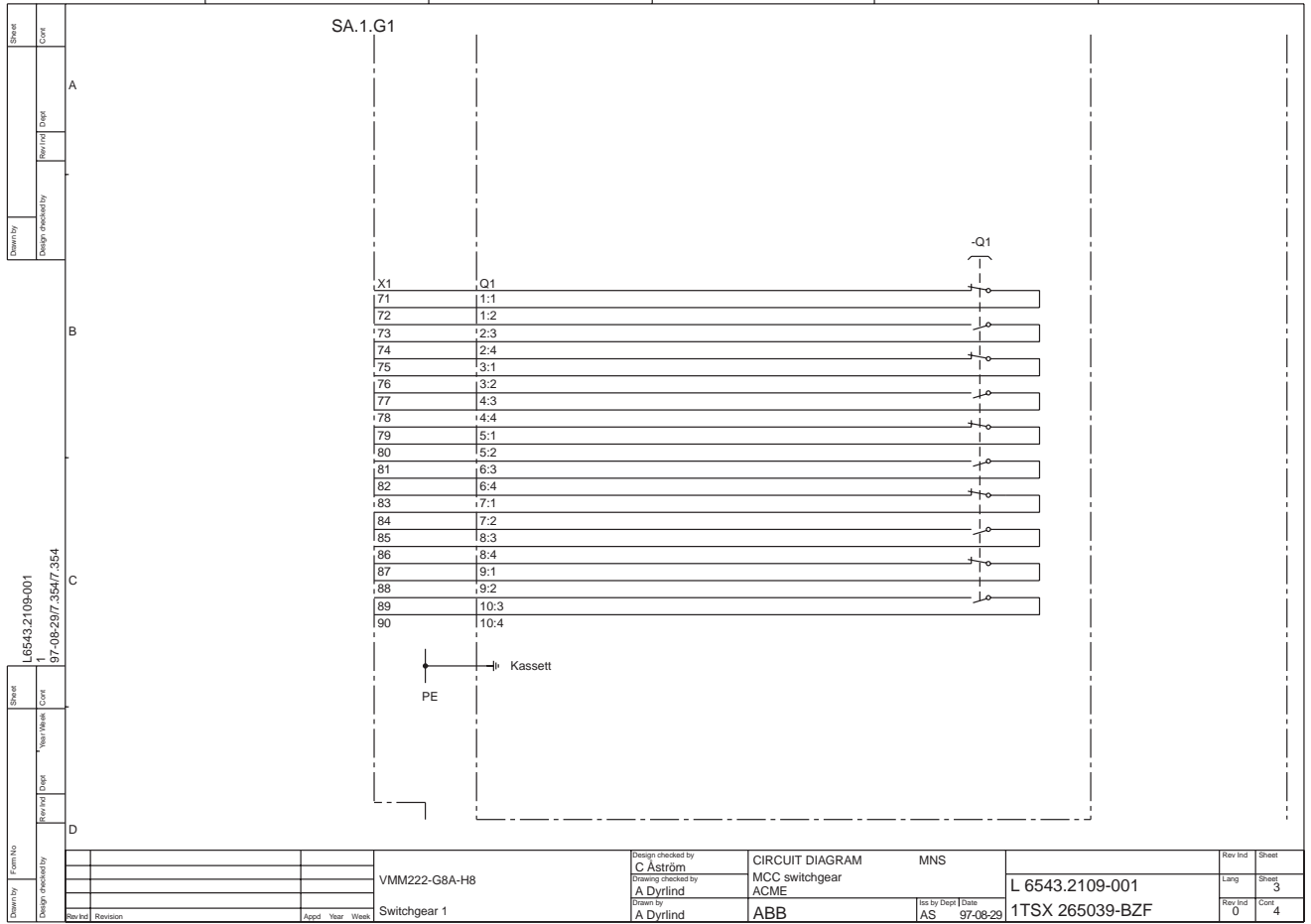

Example 4.4: Circuit diagram

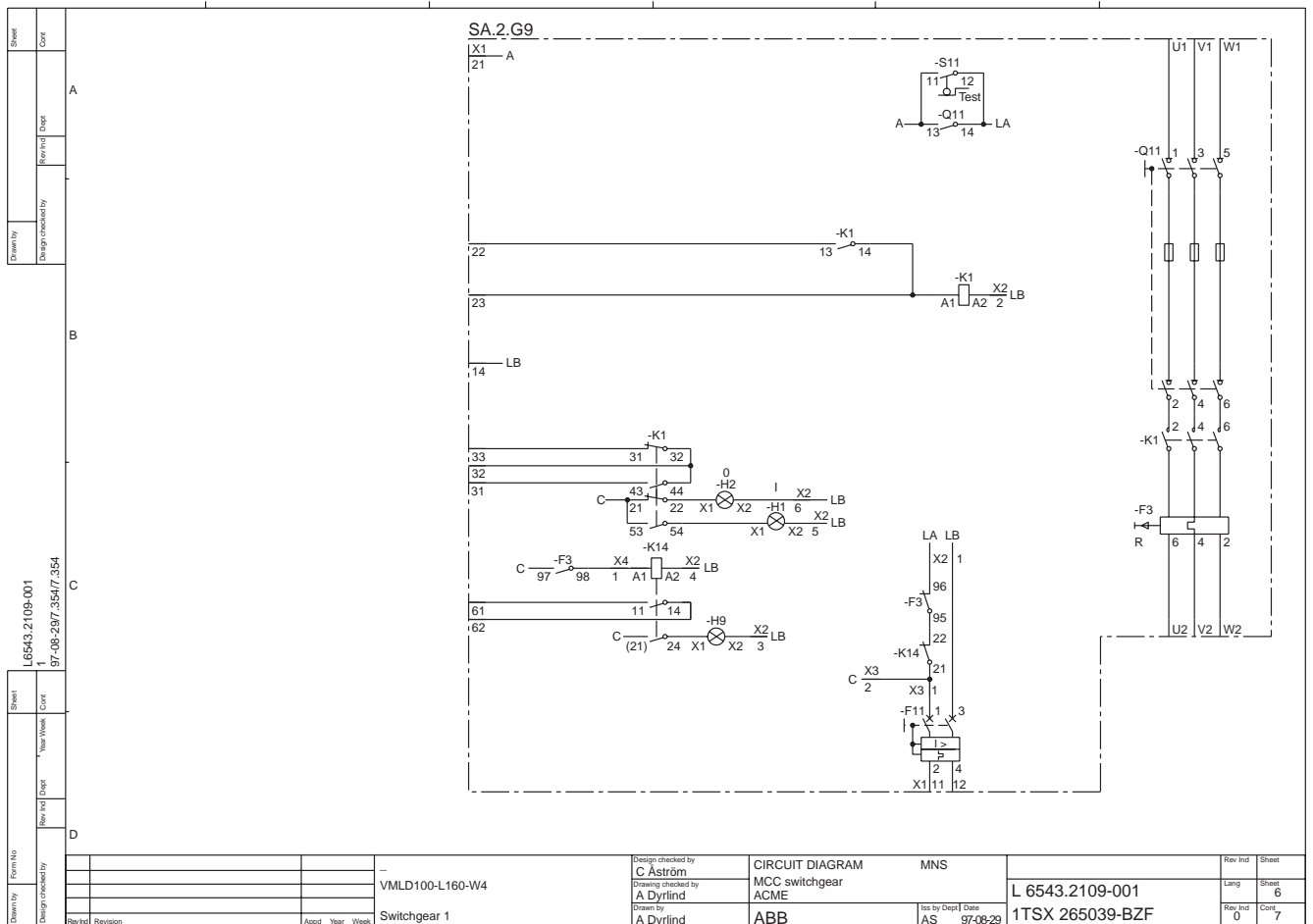























Example 7: List of labels

MCC switchgear	6543.2109-001
ACME	L6543.2109-001
	A Dyrbind
	97-08-29







































LIST OF LABELS					
Item des	Text	Pos	Height	Op	Label
SA.1	SA.1		12	G	2
SA.2	SA.2		12	G	2
SA.2.G1	G1	L	4	M	5
	—		2.5	M	
			2.5	M	
			2.5	M	
SA.2.G5	G5	L	4	M	5
	—		2.5	M	
			2.5	M	
			2.5	M	
SA.2.G9	G9	L	4	M	5
	—		2.5	M	
			2.5	M	
			2.5	M	
SA.2.G13	G13	L	4	M	5
	—		2.5	M	
			2.5	M	
			2.5	M	
SA.2.G17	G17	L	4	M	5
	—		2.5	M	
			2.5	M	
			2.5	M	

# Symbols used in diagrams

## Single-line diagram

	PLUG-IN CONTACT
	POINT OF CONNECTION FOR CABLE
	D-TYPE FUSE
	BLADE FUSE
	CIRCUIT-BREAKER
	SWITCH-DISCONNECTOR
	SWITCH-FUSE
	CONTACTOR
	THERMAL OVERLOAD RELAY
	THERMAL OVERLOAD RELAY FED FROM CURRENT TRANSFORMER
	EARTHING SWITCH
	MCB
	VOLTMETER WITH SWITCH
	CURRENT TRANSFORMER (ONE-PHASE MEASURING)
	CURRENT TRANSFORMER WITH AMPEREMETER AND MEASURING TRANSDUCER (THREE-PHASE MEASURING)
	MOTOR OPERATOR
	MANUAL SPRING CHARGING DEVICE
	SPRING CHARGING DEVICE WITH MOTOR
	OVERLOAD PROTECTION
	SHORT-CIRCUIT PROTECTION
	UNDERVOLTAGE PROTECTION

## Circuit diagram

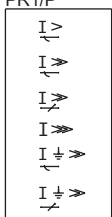
	RELAY OR CONTACTOR COIL		MEASURING TRANSDUCER
	MAKE CONTACT		VOLTAGE TRANSFORMER
	BREAK CONTACT		CURRENT TRANSFORMER
	CHANGE-OVER CONTACT		D-TYPE FUSE
	MAKE CONTACT, DELAYED WHEN CLOSING		NEUTRAL TERMINAL
	MAKE CONTACT, DELAYED WHEN OPENING		BLADE-FUSE (TOGETHER WITH SWITCH-FUSE FUSES DO NOT GET THEIR OWN ITEM DESIGNATION)
	BREAK CONTACT, DELAYED WHEN OPENING AND CLOSING		AUXILIARY RELAY
	CIRCUIT-BREAKER CONTACT		CONTACTOR WITH AUXILIARY CONTACTS
	DISCONNECTER CONTACT		THERMAL OVERLOAD RELAY WITH AUXILIARY CONTACTS
	SWITH-DISCONNECTOR CONTACT		SWITCH-DISCONNECTOR WITH AUXILIARY CONTACTS
	CONTACTOR CONTACT		SWITCH-FUSE WITH AUXILIARY CONTACTS
	MOTOR		MCB OR MCCB
	PLUG AND SOCKET (MALE AND FEMALE)		AIR CIRCUIT-BREAKER
	EARTHED SCREEN		CURRENT LIMITER TYPE PROLIM
	LAMP		EARTHING SWITCH WITH INTERLOCK MAGNET AND AUXILIARY CONTACTS
	PUSH-BUTTON SWITCH		ELECTRONIC PROTECTION FOR CIRCUIT-BREAKER
	POSITION CONTACT		
	SWITCH WITH CLOSED TRANSITION		
	SWITCH WITH SPRING RETURN FROM THE UPPER POSITION TO THE MIDDLE ONE		
	VOLTMETER SWITCH		
	VOLTMETER		
	AMPEREMETER		
			ELECTRONIC PROTECTION FOR CIRCUIT-BREAKER Overload protection, inverse time function Delayed short-circuit protection, inverse time function Delayed short-circuit protection, definite time Instantaneous short-circuit protection Earth fault protection, inverse time function Earth fault protection, definite time

# Explanation of particulars in single-line diagrams

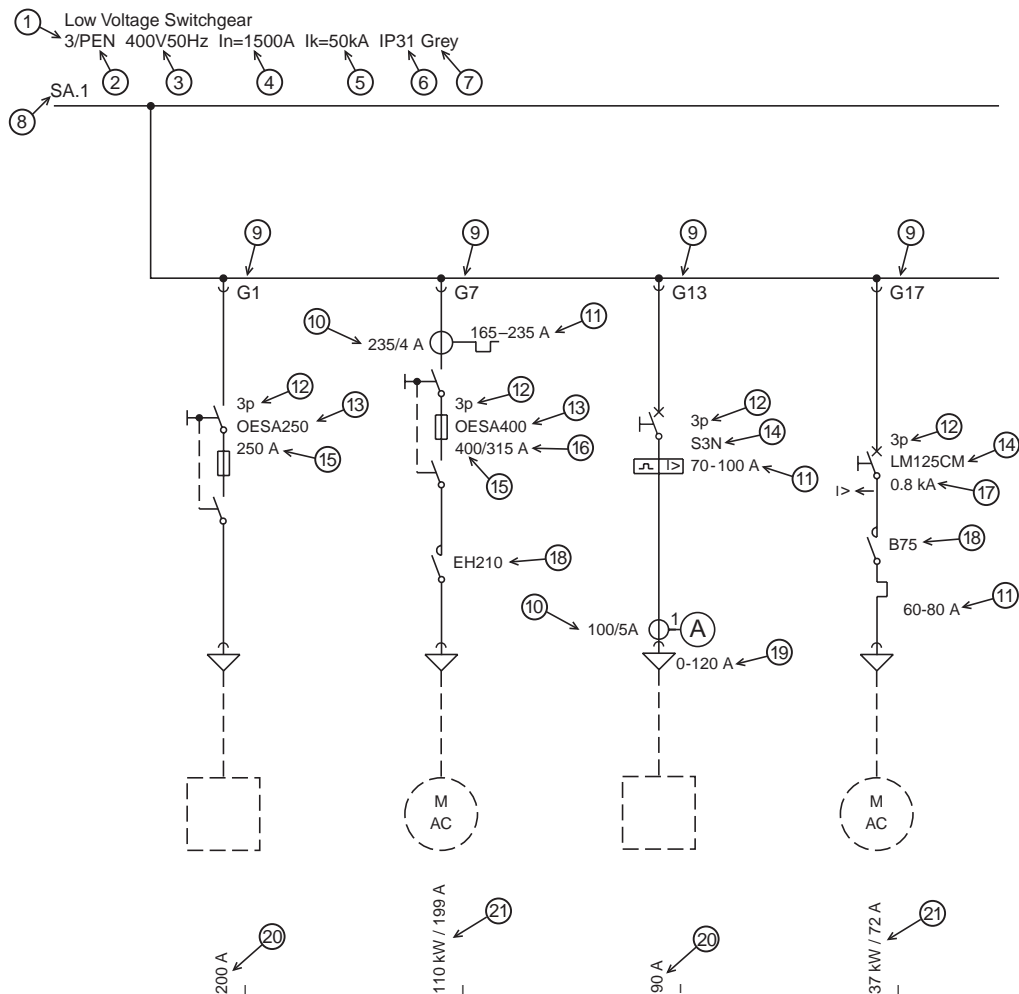

- 1 Number of phases
- 2 Earthing system
- 3 Line voltage and frequency
- 4 Rated current of horizontal busbar system
- 5 Rated short-circuit strength of the switchgear
- 6 Degree of protection
- 7 The colour of the painted panels of the switchgear
- 8 Item designation of the cubicle
- 9 Item designation of the unit
- 10 Ratio of current transformer
- 11 Setting range of overload protection
- 12 Number of poles
- 13 Type designation of switch-fuse
- 14 Type designation of circuit-breaker
- 15 Maximum allowed fuse for the fuse apparatus at the voltage and the short-circuit strength in question
- 16 Recommended fuse and normally also maximum allowed fuse with maintained coordination type 2
- 17 Recommended instantaneous setting and normally also maximum allowed setting with maintained coordination type 2
- 18 Type designation of contactor
- 19 Range scale of instrument
- 20 Current data, that which the distribution unit has been chosen according to
- 21 Power/current data, that which the motor starter has been chosen according to







---

ABB LV Systems AB  
SE-721 62 Västerås, Sweden  
Tel. +46 21 34 60 00  
Fax. +46 21 34 61 10  
[www.abb.se/lvs](http://www.abb.se/lvs)