

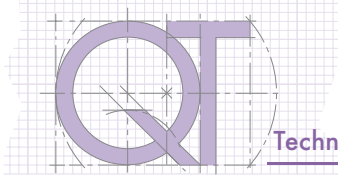
Technical Application Papers No.5

ABB circuit-breakers for direct current applications

ABB circuit-breakers for direct current applications

Index

1 Introduction	2	7 Choice of the protective device	20
2 Generalities on direct current	3	8 Use of alternating current equipment in direct current	
3 Applications	5	8.1 Variation of the magnetic field	37
3.1 Conversion of alternative energies into electrical energy	5	8.2 Connection of the CB poles in parallel	39
3.2 Electric traction	7	9 ABB offer	40
3.3 Supply of emergency services or auxiliary services	8	9.1 Automatic circuit-breakers	40
3.4 Particular industrial applications	8	9.2 Switch-disconnectors	49
4 Generation	9	<hr/>	
4.1 Storage batteries	9	Annex A: Direct current distribution systems	51
4.2 Static conversion	10	Annex B: Calculation of short-circuit currents	54
4.3 Dynamo	11	Annex C: Circuit-breakers and switch-disconnectors for applications up to 1000Vd.c.	57
5 Remarks on the interruption of direct current	12	Glossary	61
6 Typologies of d.c. networks			
6.1 Network insulated from earth	14		
6.2 Network with one polarity earthed.....	16		
6.3 Network with the middle point of the supply source connected to earth	18		



1 Introduction

Direct current, which was once the main means of distributing electric power, is still widespread today in the electrical plants supplying particular industrial applications.

The advantages in terms of settings, offered by the employ of d.c. motors and by supply through a single line, make direct current supply a good solution for railway and underground systems, trams, lifts and other transport means.

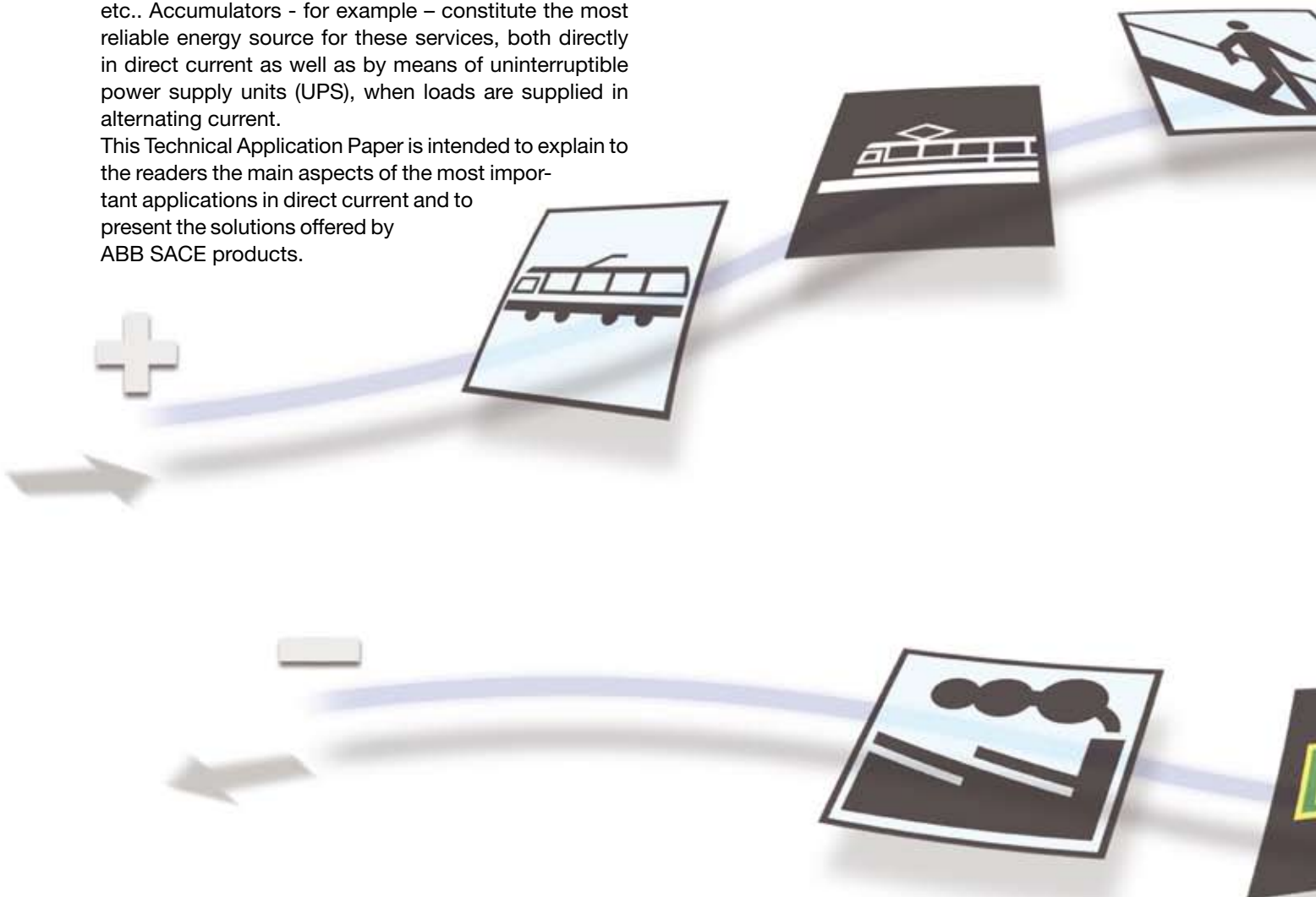
In addition, direct current is used in conversion plants (installations where different types of energy are converted into electrical direct energy, e.g. photovoltaic plants) and, above all, in those emergency applications where an auxiliary energy source is required to supply essential services, such as protection systems, emergency lighting, wards and factories, alarm systems, computer centers, etc.. Accumulators - for example - constitute the most reliable energy source for these services, both directly in direct current as well as by means of uninterruptible power supply units (UPS), when loads are supplied in alternating current.

This Technical Application Paper is intended to explain to the readers the main aspects of the most important applications in direct current and to present the solutions offered by ABB SACE products.

The main purpose is giving precise information by means of tables providing a rapid choice of the protection/disconnection device and paying particular attention to the installation characteristics (fault typologies, installation voltage, earthing arrangement).

There are also some annexes giving further information about direct current, and more precisely:

- information about the distribution systems in compliance with the international Standard IEC 60364-1;
- calculation of the short-circuit current in d.c. in compliance with the international Standard IEC 61660-1;
- circuit-breakers and disconnectors for applications up to 1000Vd.c.



2 Generalities on direct current

Knowing the electrical characteristics of direct current and its differences in comparison with alternating current is fundamental to understand how to employ direct current.

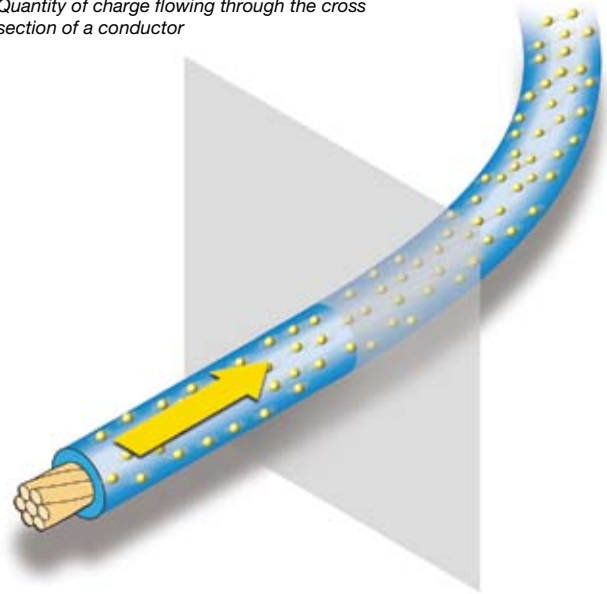
For definition, the electric current called “direct” has a unidirectional trend constant in time. As a matter of fact, by analyzing the motion of the charges at a point crossed by a direct current, it results that the quantity of charge (Q) flowing through that point (or better, through that cross section) in each instant is always the same.

The sources which can provide direct current are batteries or dynamos; besides, through a rectifying process it is possible to convert an alternating current into a direct current.

However, a “pure” direct current, that is a current which does not present any periodic fluctuation, is generated exclusively by batteries (or accumulators). In fact,

the current produced by a dynamo can present small variations which make it not constant in time; nonetheless, from a practical point of view, this is considered a direct current.

Figure 1
Quantity of charge flowing through the cross section of a conductor



In a d.c. system, respecting the current direction has a remarkable importance; therefore it is necessary to connect correctly the loads by respecting the polarities, since, in case of a wrong connection, operation and safety problems could arise.

For example, if a d.c. motor were supplied by reversing the polarities, it would rotate in the reverse direction and many electronic circuits when supplied in the wrong way could also suffer irreversible damages.



R.m.s. value of a sinusoidal quantity

The r.m.s. value is the parameter which relates alternating to direct current.

The r.m.s. value of an alternating current represents the direct current value which causes the same thermal effects in the same period of time; for example, a direct

current of 100A produces the same thermal effects of a sinusoidal alternating current with the maximum value of 141A.

Thus the r.m.s. value allows alternating current to be treated as direct current where the instantaneous value varies in time.

$$I_{r.m.s} = \sqrt{\frac{1}{T} \int_0^T i^2(t) dt} \quad (\text{where } T \text{ is the period})$$

Figure 2 Periodic waveform at 50Hz

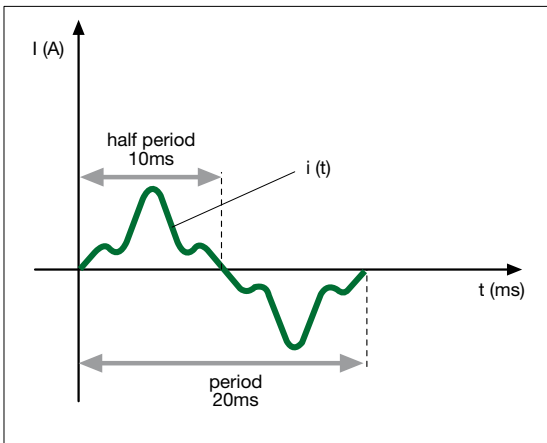
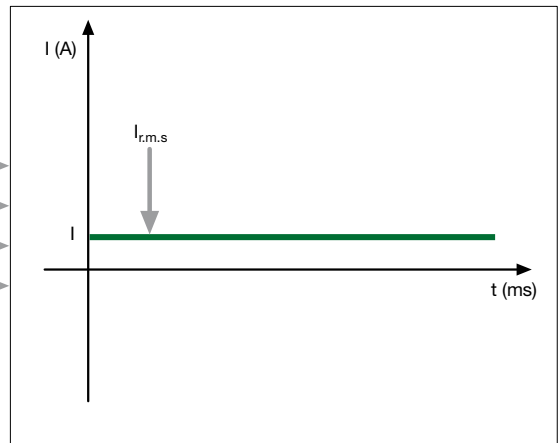


Figure 3 R.m.s. value (value of the equivalent direct current)



The r.m.s. value of a perfectly sinusoidal waveform is equal to:

$$I_{r.m.s} = \frac{I_{max}}{\sqrt{2}} \quad (\text{where } I_{max} \text{ is the maximum value of the amplitude of the sinusoidal waveform})$$

Figure 4 Sinusoidal waveform at 50Hz

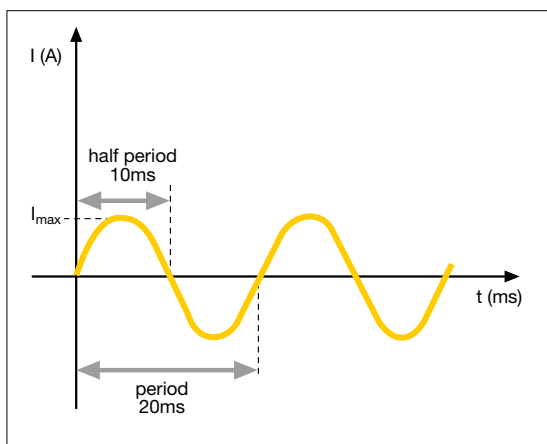
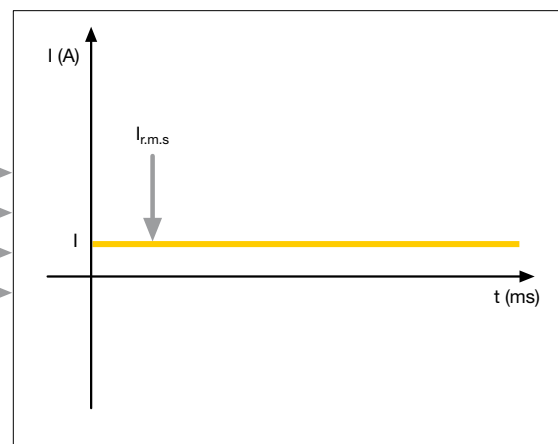


Figure 5 R.m.s. value (value of the equivalent direct current)



3 Applications

In the low voltage field, direct current is used for different applications, which, in the following pages, have been divided into four macrofamilies including:

- conversion into other forms of electrical energy (photovoltaic plants, above all where accumulator batteries are used);
- electric traction (tram-lines, underground railways, etc.);
- supply of emergency or auxiliary services;
- particular industrial installations (electrolytic processes, etc.).

3.1 Conversion of alternative energies into electrical energy

Photovoltaic plants

A photovoltaic plant permits to convert the energy associated with solar irradiation into electrical energy of direct type; these plants are constituted by panels of semiconducting material, which can generate electrical power once exposed to the rays of the sun.

Photovoltaic plants can be grid-connected or supply a single load (stand alone plant). In this last case an accumulator battery shall be present to provide power supply in case of lack of solar radiation.

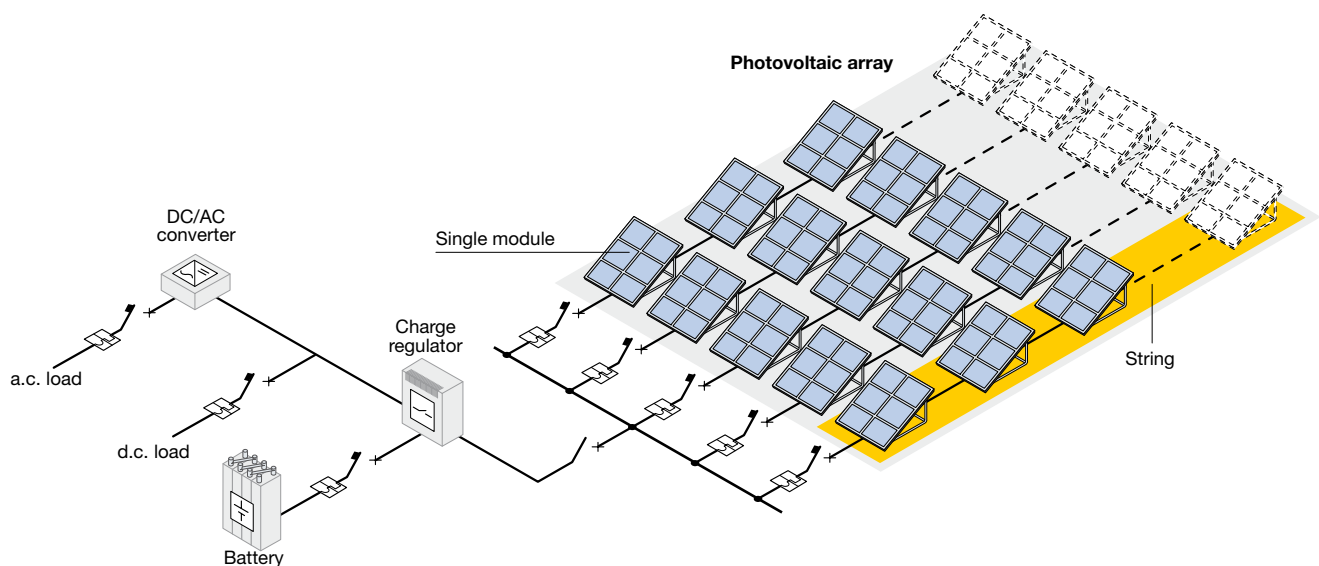
The basic element of a photovoltaic plant is the photovoltaic cell constituted by semiconducting material (amorphous silicon or monocrystalline silicon); this cell, exposed to the rays of the sun, is able to supply a maximum current I_{mpp} at a maximum voltage V_{mpp} , which a maximum power called W_p corresponds to. More photovoltaic cells are connected in series to form a string to raise the voltage level; by connecting more strings in parallel, the current level is increased.

For example, if a single cell can provide 5A at 35.5 Vd.c., in order to reach the level of 100A at 500 Vd.c., it is necessary to connect 20 strings in parallel, each of them constituted by 15 cells.

Generally speaking, a stand alone photovoltaic plant is constituted by the following devices:

- **photovoltaic array:** constituted by the photovoltaic cells suitably interconnected and used for the conversion of sunlight energy into electrical energy;
- **charge regulator:** it is an electronic device able to regulate charging and discharging of accumulators;
- **accumulator batteries:** they can provide power supply in case of lack of solar radiation;
- **DC/AC inverter:** it has the function of turning direct current into alternating current by controlling it and stabilizing its frequency and waveform.

The following figure shows the block diagram of a stand alone photovoltaic plant.



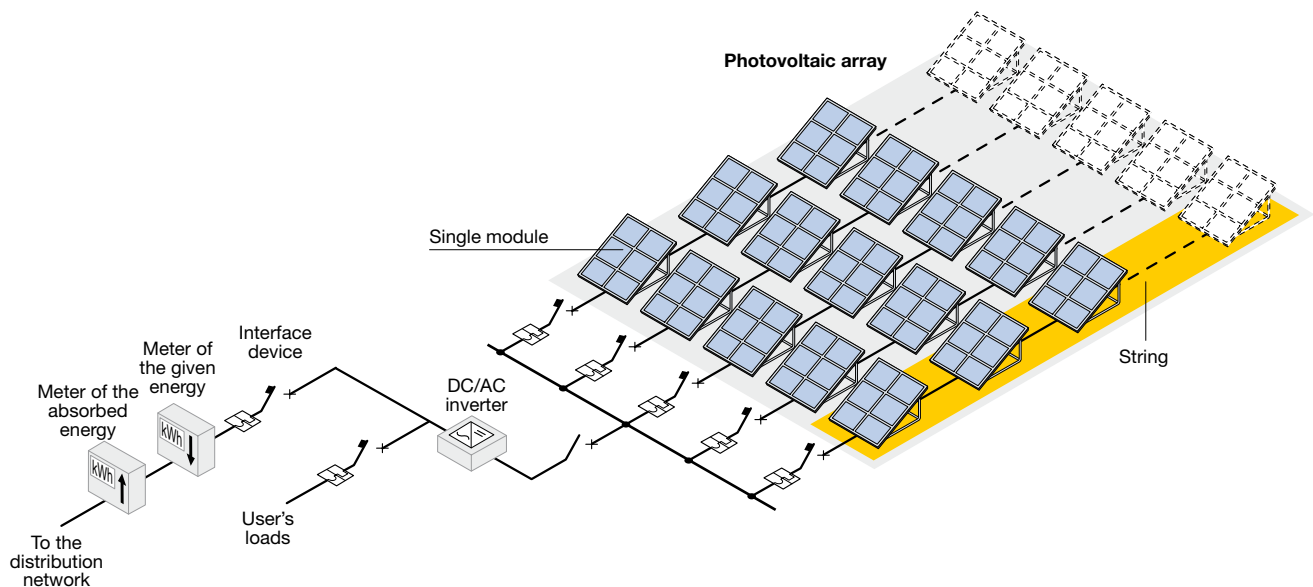
The general diagram of a grid-connected photovoltaic plant, unlike a stand alone one, may leave out the accumulator battery since, when solar irradiation is unavailable, the user is supplied by the network.

A photovoltaic plant of this type is constituted by the following equipment:

- **photovoltaic array:** constituted by the photovoltaic cells suitably interconnected and used for the conversion of sunlight energy into electrical energy;
- **DC/AC inverter:** it has the function of turning direct

- current into alternating current by controlling it and stabilizing its frequency and waveform;
- **interface device:** it is constituted by a circuit-breaker equipped with an undervoltage release or with a switch-disconnector able to guarantee the total separation of the power generation units from the public utility network;
- **energy meters:** they are present to measure and invoice the energy supplied and absorbed by the distribution network.

The following figure shows the block diagram of a grid-connected photovoltaic plant.



Photovoltaic plants can supply currents from a few dozens of Amperes (domestic applications and similar) up to several hundreds of Amperes (service industry and small industry).

3.2 Electric traction

The particular torque-speed characteristic curve and the ease with which the speed itself can be regulated have led to the use of d.c. motors in the field of electric traction. Direct current supply gives also the great advantage of having the contact line consisting of a single conductor since the rails provide the return conductor.

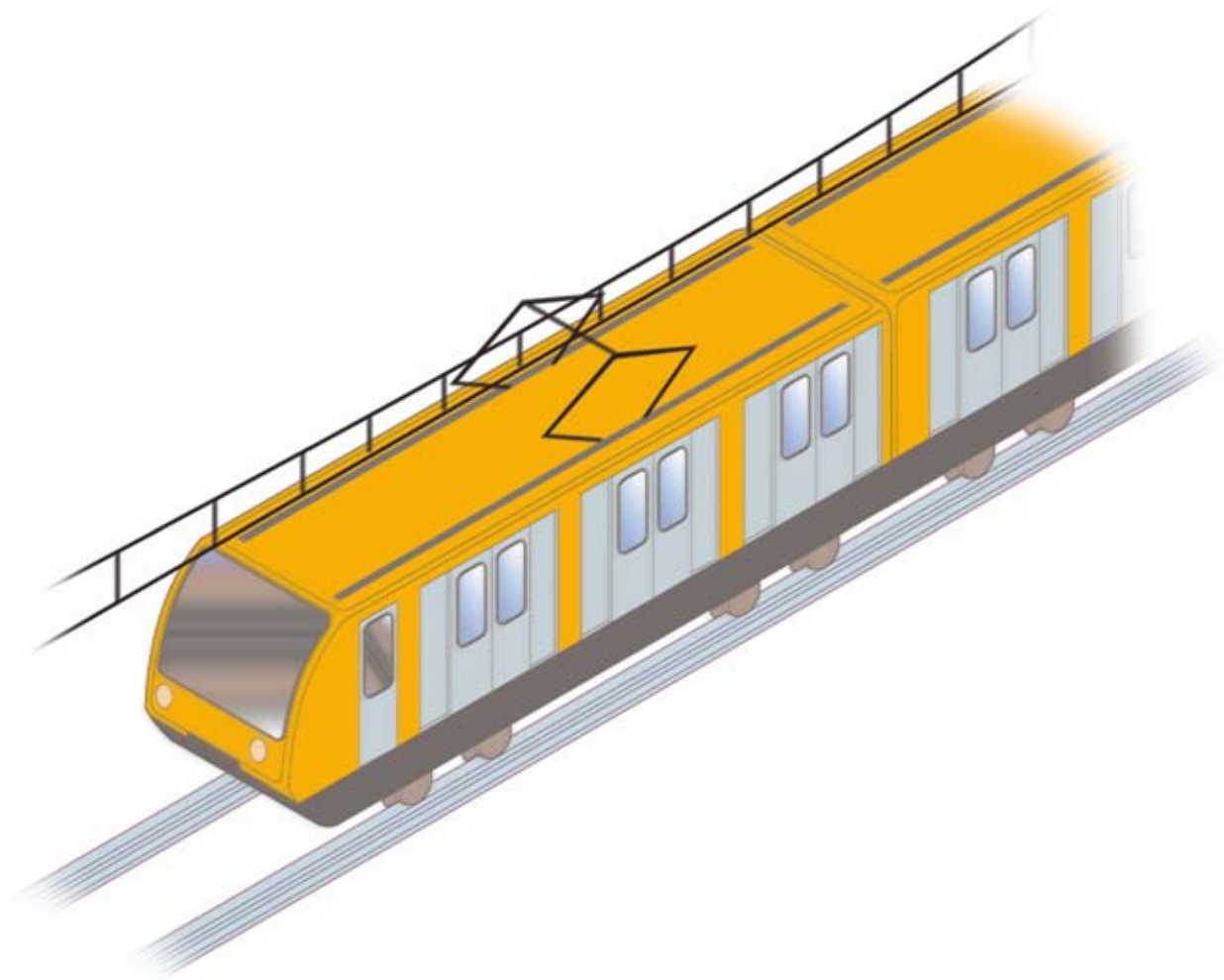
In the present scenario, direct current is used above all in urban transport, that is trolleybuses, trams, underground railways with a supply voltage of 600V or 750V, up to 1000V.

The use of direct current is not limited to vehicle traction only, but direct current represents a supply source for the auxiliary circuits on board vehicles; in such cases accumulator batteries are installed, which constitute an auxiliary power supply source to be used if the external one should fail.

It is very important that this power supply is guaranteed since the auxiliary circuits may supply essential services, such as: air conditioning plants, internal and external lighting circuits, emergency brake systems, electrical heating systems, etc....

The applications of circuit-breakers in d.c. circuits for electric traction in general can be summarized as follows:

- protection and operation of both overhead and rail contact lines;
- protection of air compressors on board underground and train cars;
- protection of distribution plants for services and signaling systems;
- protection of d.c. supply sources (accumulator batteries)
- protection and operation of d.c. motors.



3.3 Supply of emergency services or auxiliary services

Direct current is used (directly or indirectly through accumulator batteries) for all those plants for which service continuity represents a fundamental requirement.

Such plants, which cannot tolerate a power failure caused, for example, by a loss of energy, need a ready-to-use supply source, which, even if limited in time, can be however able to cover the times necessary for the starting of an emergency generating set.

Here are some examples of this type of user plants:

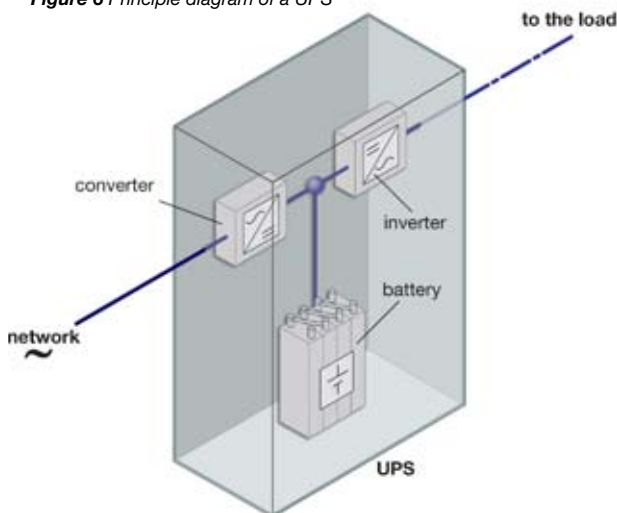
- industrial applications (process control systems);
- safety and emergency installations (lighting, alarms);
- hospital applications;
- telecommunication;
- applications in the data processing field (data centers, work stations, servers, etc...).

In these installations, energy interruptions cannot be permitted; therefore, it is necessary to insert in the plant systems able to store energy during the presence of supply and to give it back immediately when energy fails.

Accumulator batteries constitute the most reliable electric energy source for the supply of such services, both directly in direct current (if allowed by the loads) as well as in alternating current by using an inverter able to develop an outgoing sinusoidal waveform starting from an incoming continuous one.

The above is carried out by the uninterruptible power supply units (UPS):

Figure 6 Principle diagram of a UPS



3.4 Particular industrial applications

The use of direct current is often required in many industrial applications, such as:

- arc furnaces;
- electrowelding plants;
- graphite manufacturing plants;
- metal production and refining plants (aluminum, zinc, etc...).

In particular, many metals, as aluminum, are produced through an electrolytic process. Electrolysis is a process which converts electric energy into chemical energy. It is the opposite of what occurs in the battery process. In fact, with the battery, a chemical reaction is exploited to produce d.c. electric energy, whereas electrolysis uses d.c. electric energy to start a chemical reaction which otherwise would not occur spontaneously.

The procedure consists in immersing the metal to be refined, which acts as an anode, in a conductive solution, while a thin plate made of the same pure metal acts as a cathode; by applying a direct current from the rectifiers, it is possible to observe that the metal atoms on the anode dissolve in the electrolytic solution and, at the same time, an equivalent quantity of metal settles on the cathode. In these applications, the service currents are very high >3000A.

Another very common application is represented by galvanizing plants, where processes are carried out to obtain the plating of metallic surfaces with other metals or alloys (chromium plating, nickeling, coppering, brass coating, galvanization zinc plating, tinning, etc...). The metallic piece to be plated usually acts as a cathode: by the current flow, the ions shall move from the anode and shall settle on the piece surface.

Also in these installations, the operations are carried out by means of an electrolytic cell with high service currents (up to 3000A and over).

4 Generation

Direct current can be generated:

- by using batteries or accumulators where the current is generated directly through chemical processes;
- by the rectification of alternating current through rectifiers (static conversion);
- by the conversion of mechanical work into electrical energy using dynamos (production through rotating machines).

The following indications are not intended to be an exhaustive tool, but they are aimed at giving, in an easy language, some useful information to help in the understanding of the main technologies for the production of direct current; it is clear that the technology and techniques used nowadays are manifold and complex, but since they are not the main topic of this technical paper, only the basic indications necessary for a quick comprehension are given.

4.1 Storage batteries

A storage battery, or accumulator, is an electrochemical generator able to convert chemical energy directly into electrical energy of direct type.

The structure of a storage battery is analogous to that of a normal battery. The main difference is that with accumulator batteries the discharging/charging process is reversible: in fact, by using a DC generator, it is possible to restore the initial status of the electrodes which have been altered during discharge; such process cannot be carried out with a normal battery.

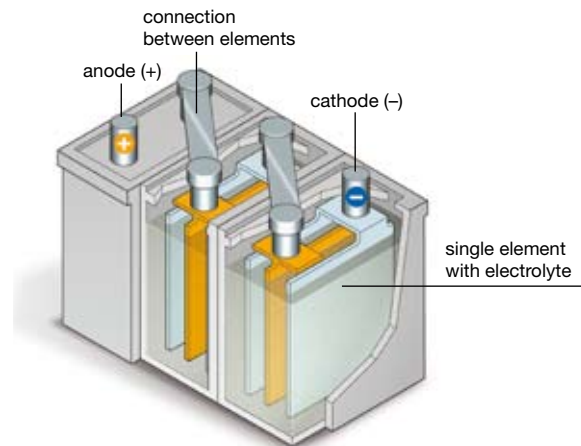
The main electrical characteristics of storage batteries are:

- **nominal voltage:** potential difference existing between the negative and positive plates immersed in the electrolyte; the voltage value usually reported is related to each single cell (2V, 4V, 6V, 12V); to obtain the required voltage it is necessary to use more cells in series
- **capacity:** quantity of electricity which a battery can deliver for a defined time; capacity is expressed in ampere-hours (Ah) and can be obtained by multiplying the value of the intensity of the discharge current (Ampere) by the discharge time (hours)
- **internal resistance:** the value of the internal resistance of the battery; this value is given by the manufacturer
- **power:** power which the battery can deliver; it is obtained from the average discharge voltage multiplied by the current and it is expressed in watt (W).

Structure of a storage battery

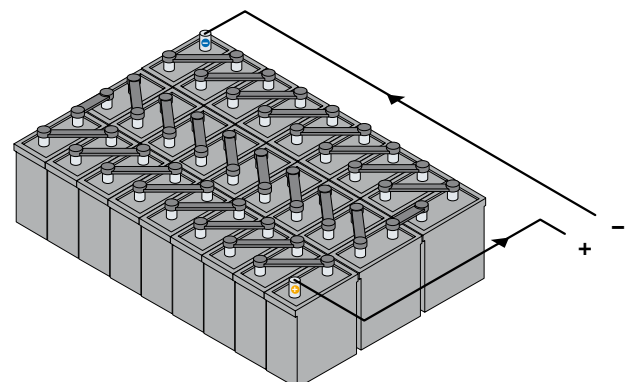
A stationary battery in its easiest form is constituted by a recipient containing a sulfuric acid solution with distilled water (the electrolyte) where the two electrodes – the positive one and the negative one - are immersed. Each of them is formed by one or more plates connected in parallel; the terminals of these electrodes, to which the loads shall be connected or where the connections in series or in parallel shall be made, are the anode (+) and the cathode (-).

The following figure shows the possible structure of three elements connected in series:



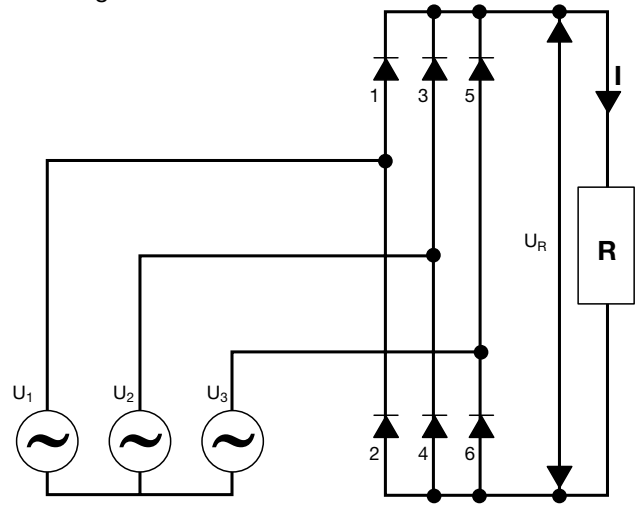
In addition to these components, there are also current collectors and separators. The collectors direct the generated current towards the electrodes (discharging phase) and vice versa from the electrodes towards the elements (charging phase) and the separators, usually constituted by insulating plates, avoid the contact between anode and cathode to prevent the formation of short-circuits. To obtain the voltage level related to the installation requirements, it is necessary to connect (through suitable connectors, see figure) more cells in series or in parallel to increase the voltage or the current level.

The following figure shows the possible structure of three elements connected in series:



4.2 Static conversion

Direct current can be supplied by using electronic devices (rectifiers) able to convert alternating current input into direct current output. Such devices are also called static converters to distinguish them from the rotating ones, nowadays obsolete equipment, which use more electrical machines suitably coupled. The operating principle of rectifiers exploits the properties of the electronic components made of semiconductor materials (diodes, thyristors, etc.), that is their capacity of carrying currents only when positively polarized. The operating principle can be described by taking into consideration the three-phase bridge rectifier (Graetz rectifier) shown in the figure:

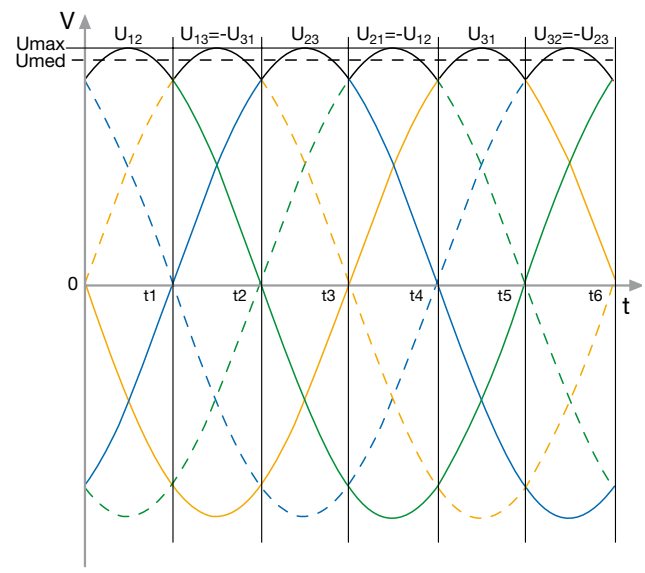


In this diagram it is possible to identify the three forward diodes (1,3,5) having the cathodes connected in common and the three backward diodes (2,4,6) which instead have the anodes connected in common.

Having established that a diode carries current only if positively polarized, that is when the voltage at its ends is higher than zero, by supplying the bridge circuit with a set of three-phase voltages, it results:

- a) during the first sixth of period, the line-to-line voltage U_{12} is the prevailing voltage; as a consequence diodes 1 and 4 shall carry the current
- b) during the second sixth of period, the line-to-line voltage U_{13} is the prevailing voltage; as a consequence, diodes 1 and 6 shall carry the current.

The same occurs in the subsequent fractions of period. The voltage U_R at the terminals of the load R is the voltage represented by the envelope of the line-to-line voltages as shown in the figure.



The continuous lines represent the three sine curves of the line-to-line voltages (U_{12} ; U_{23} ; U_{31}), whereas the dotted lines represent the sine curves of the same voltages but reversed ($U_{13} = -U_{31}$; $U_{21} = -U_{12}$; $U_{32} = -U_{23}$).

The resulting output voltage (represented by the continuous black line) takes the waveform of a ripple voltage with average value not null. Therefore, the direct current which flows through the resistance R shall be equal to:

$$I = \frac{U_{med}}{R}$$

In fact the electronic circuit of a rectifier is more complex than the circuit just shown; for example, a capacitor which "smoothes" the output voltage is often present to reduce ripple. Besides, thyristors can be used instead of diodes; thyristors, thanks to the possibility of controlling their switching-on time in relation with their switching instant, allow to vary the output voltage value at the bridge; in this case, this device is referred to as a controlled bridge rectifier.

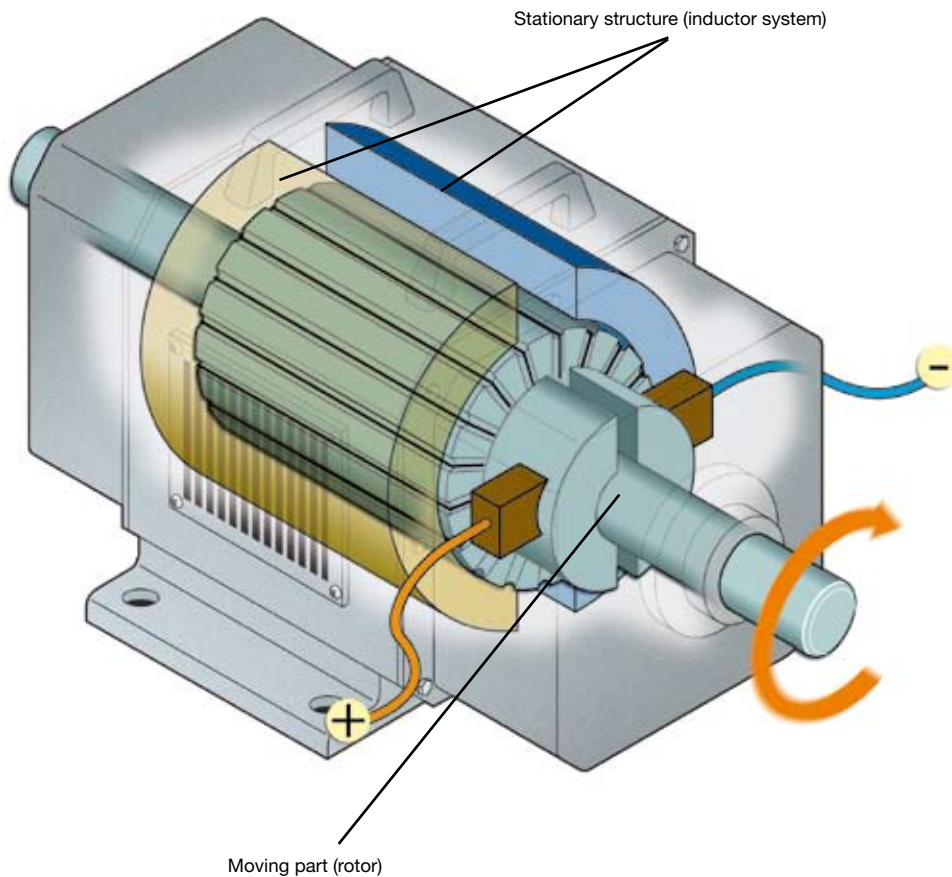
4.3 Dynamo

A dynamo is a direct current generator used to convert kinetic energy into electrical energy of direct type.

As shown in the figure, these devices consist chiefly of a stationary structure (called inductor system), having the task of generating a magnetic field, and of a moving part (called rotor), constituted by a system of conductors, which shall be “struck” by the magnetic field generated by the inductor.

Starting from the assumption that a straight-line conductor (positioned along a cylinder rotating at constant speed) cutting the lines of force of the magnetic field becomes the seat of an induced electromotive force (emf) variable in time, it is easy to understand that with more conductors suitably connected (so that the positive and negative values of the electromotive forces induced in the conductors are compensated), it is possible to obtain a resulting emf of constant value having always the same direction.

The following figure shows the structure of a dynamo:



5 Remarks on the interruption of direct current

Direct current presents different problems than alternating current with regard to the phenomena associated to the interruption of high value currents since the arc extinction results to be particularly difficult.

As Figure 7 shows, with alternating current there is natural passage of current through zero at each half cycle, which corresponds to the quenching of the arc during the circuit opening. With direct current there is not such natural passage and therefore, to guarantee arc extinction, the current must decrease to null (forcing the current passage through zero).

Figure 7 Alternating current

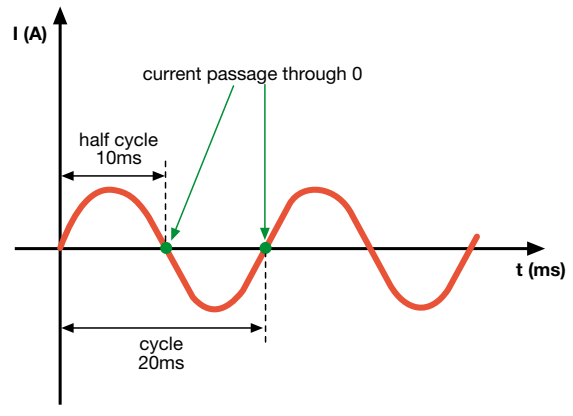
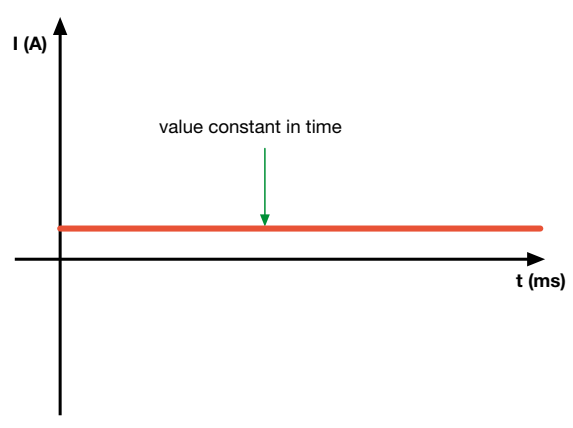
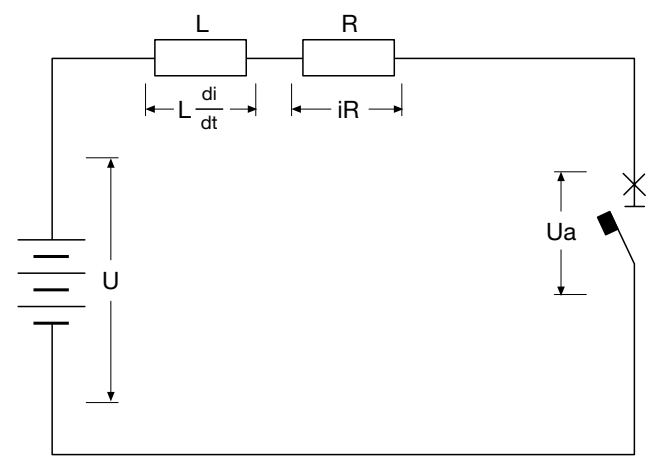


Figure 8 Direct current



To understand the above, reference to the circuit shown in the figure shall be made:



In this case:

$$U = L \frac{di}{dt} + Ri + Ua$$

where:

- U is the rated voltage of the supply source
- L is the inductance of the circuit
- R is the resistance of the circuit
- Ua is the arc voltage.

The formula can be written also as:

$$L \frac{di}{dt} = U - Ri - Ua \quad (1)$$

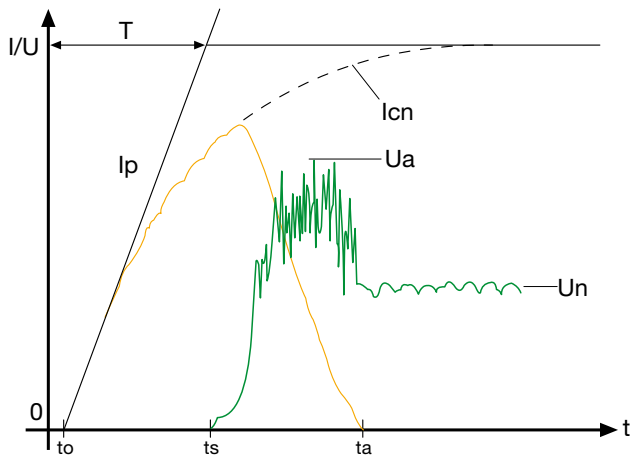
To guarantee arc extinction, it is necessary that:

$$\frac{di}{dt} < 0$$

This relationship shall be verified when the arc voltage (Ua) is so high that the first member of the formula (1) becomes negative. Apart from mathematical considerations deriving from the integration of formula (1), it is possible to conclude that the extinction time of a direct current is proportional to the time constant of the circuit $T = L/R$ and to the extinction constant.

The extinction constant is a parameter depending on the arc characteristic and on the circuit supply voltage.

The following figure shows an oscillogram relative to a short-circuit test carried out in ABB SACE power testing laboratories.



- I_p = short-circuit making current
- I_{cn} = prospective short-circuit current
- U_a = maximum arc voltage
- U_n = network voltage
- T = time constant
- t_0 = instant of beginning of short-circuit
- t_s = instant of beginning of separation of the CB contacts
- t_a = instant of quenching of the fault current

When a short-circuit occurs, in correspondence to the instant t_0 , the current starts rising according to the time constant of the circuit. The circuit-breaker contacts begin separating, thus striking an arc starting from the instant t_s .

The current keeps on rising for a short instant also after the beginning of contact opening, and then decreases depending on the value higher and higher of the arc

resistance progressively introduced in the circuit. As it can be noticed in the graph, the arc voltage keeps higher than the supply voltage of the circuit during the interruption. In correspondence of t_a , the current is completely quenched.

As the graph shows, the short-circuit current represented by the red line is extinguished without abrupt interruptions which could cause high voltage peaks.

As a consequence, to obtain a gradual extinction (the graph represents the descent of I_p), it is necessary to cool and extend the arc, so that a higher and higher arc resistance is inserted in the circuit (with the consequent increase of the arc voltage U_a). This extinction involves energetic phenomena which depend on the voltage level of the plant (U_n) and lead to install circuit-breakers according to connection diagrams in series to the advantage of the performances under short-circuit conditions (as a matter of fact, the higher is the number of contacts opening the circuit, the higher is the breaking capacity of the circuit-breaker).

This means that, when the voltage rises, it is necessary to increase the number of current interruptions in series, so that a rise in the arc voltage is obtained and consequently a number of poles for breaking operation suitable to the fault level.

As regards the pole connection referred to network typologies, see Chapter 7: "Choice of the protective device".

To summarize: in order to guarantee breaking of a short-circuit current in a d.c. system it is necessary to employ circuit-breakers which can ensure:

- rapid tripping with adequate breaking capacity;
- high fault current limiting capacity;
- overvoltage reduction effect.

6 Typologies of d.c. networks

As previously explained, in order to break a short-circuit current in a d.c. system, it is necessary to connect the CB poles in a suitable way.

To carry out this operation, it is necessary to know the earthing typology of the plant.

Such information allow any possible fault condition to be evaluated and consequently the most suitable connection type to be selected according to the other characteristics of the plant (short-circuit current, supply voltage, rated current of the loads, etc.).

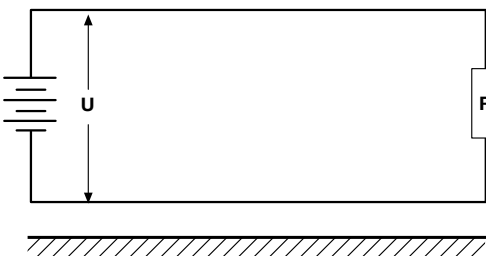
The following pages shall give for each network typology these fundamental information:

- description of the network;
- fault typologies;

(as regards the pole connection and the relevant breaking capacity see Chapter 7: "Choice of the protective device").

Common solution

Figure 9 Network insulated from earth



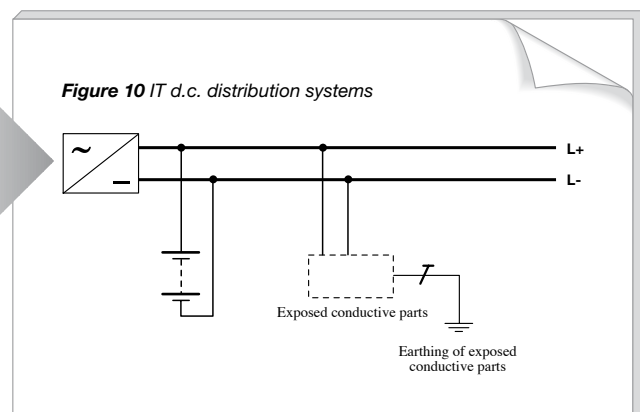
6.1 Network insulated from earth

This type of network represents the easiest connection to carry out, since no connection between the battery polarities and earth are provided.

These types of systems are widely used in those installations where earthing results to be difficult, but above all where service continuity is required after a first earth fault (see the following pages).

On the other hand, since no polarities are earthed, this connection presents the inconvenience that dangerous overvoltages could occur between an exposed conductive part and earth due to static electricity (such hazards can be limited by overload dischargers).

Representation in compliance with Std. IEC 60364-1*

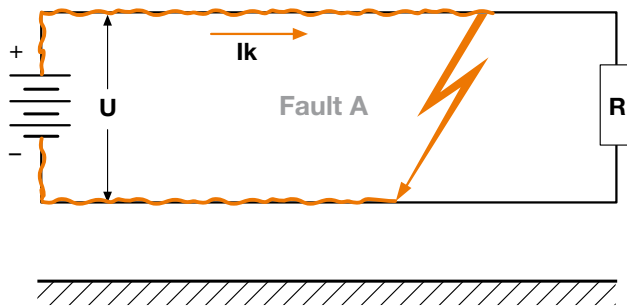


*such analogy is valid for the earthing of the supply source only and not for the earthing of the exposed-conductive-parts; besides, as far as the prescriptions concerning indirect contacts are concerned, please refer to Std. IEC 60364-4.

Fault typologies in a network insulated from earth

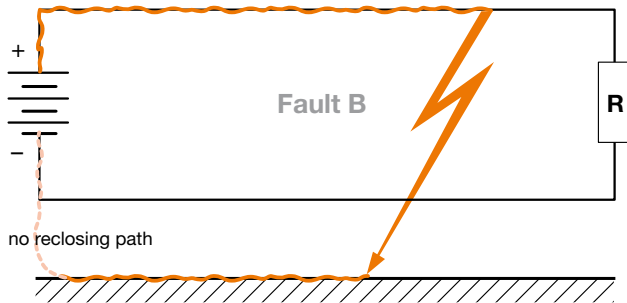
Fault A:

the fault between the two polarities is a short-circuit current fed by the full voltage U . The breaking capacity of the circuit-breaker shall be chosen according to the short-circuit current relevant to such fault.



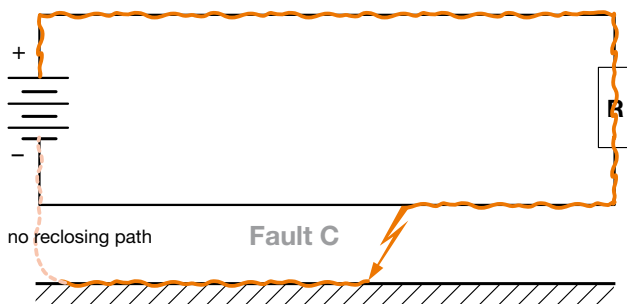
Fault B:

the fault between a polarity and earth has no consequences from the point of view of the plant operation since such current has no reclosing paths and consequently it cannot circulate.



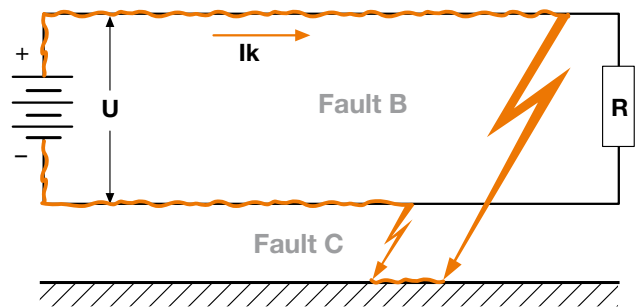
Fault C:

also this fault (as fault B) between a polarity and earth has no consequences from the point of view of the plant operation.



Double fault (fault B + fault C):

in case of a double fault, as shown in the figure, the current might circulate and find a reclosing path; in this case, it is advisable that a device capable of signaling an earth fault or a decrease of the insulation to earth of a polarity is installed in the plant; thus, the fault is eliminated in good time to prevent the occurrence of a second earth fault on the other polarity and the consequent total inefficiency of the plant due to the tripping of the CB caused by the short-circuit generated on the two polarities to earth.

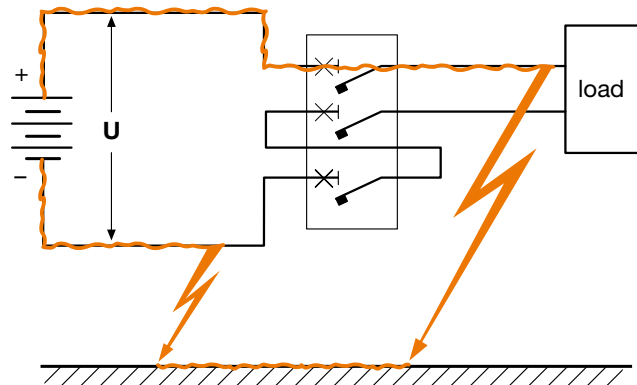


Conclusions

with this typology of network, the fault type which affects the version and connection of the CB poles is fault A (between the two polarities).

In an insulated network it is necessary to install a device able to signal the presence of the first earth fault so that it can be eliminated to avoid any problem arising from a second earth fault. In fact, in case of a second earth fault, the CB could have to interrupt the fault current, under the worst conditions, with the full voltage applied to a single polarity and consequently with an insufficient arc voltage (see figure).

Figure 11 Double fault in a network insulated from earth

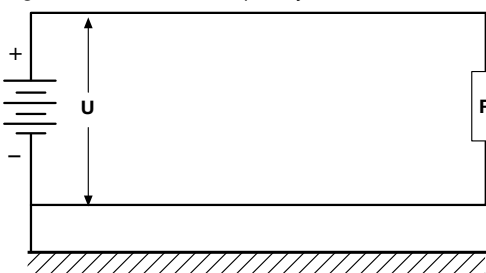


6.2 Network with one polarity earthed

This typology of network is obtained by connecting to earth one polarity (either the negative or the positive one).

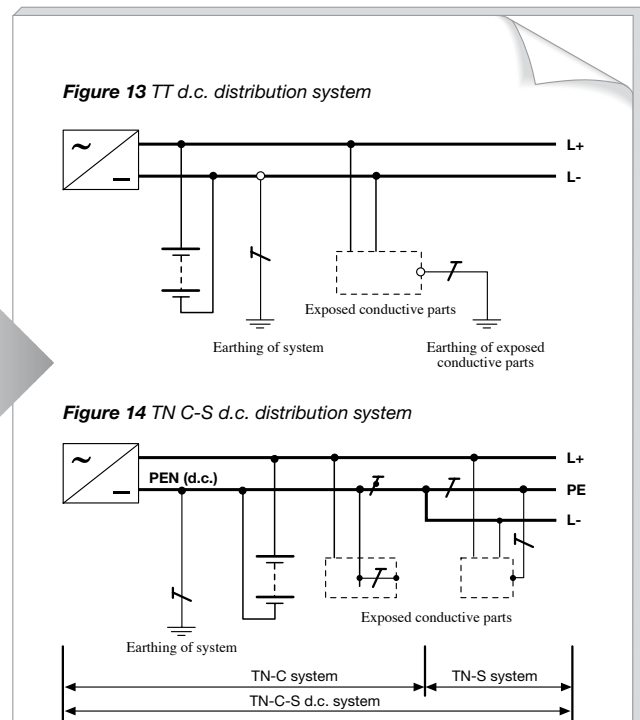
Common solution

Figure 12 Network with one polarity earthed



This connection type allows the overvoltages due to static electricity to be discharged to earth.

Representation in compliance with Std. IEC 60364-1*



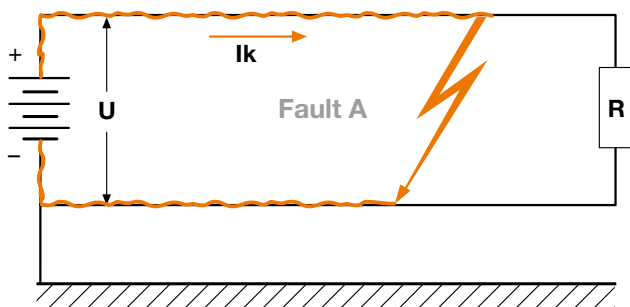
*such analogy is valid for the earthing of the supply source only and not for the earthing of the exposed-conductive-parts; besides, as far as the prescriptions concerning indirect contacts are concerned, please refer to Std. IEC 60364-4.

Fault typologies in a network with one polarity earthed

(in the following examples the earthed polarity is the negative one)

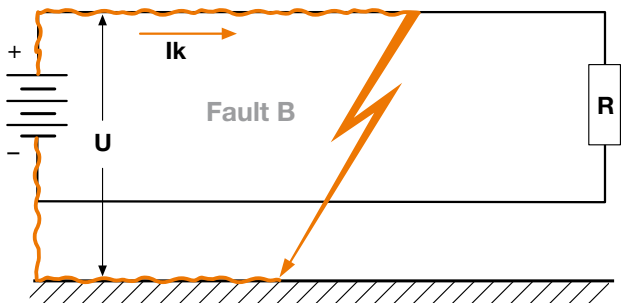
Fault A:

the fault between the two polarities is a short-circuit current fed by the full voltage U . The breaking capacity of the circuit-breaker shall be chosen according to the short-circuit current relevant to such fault.



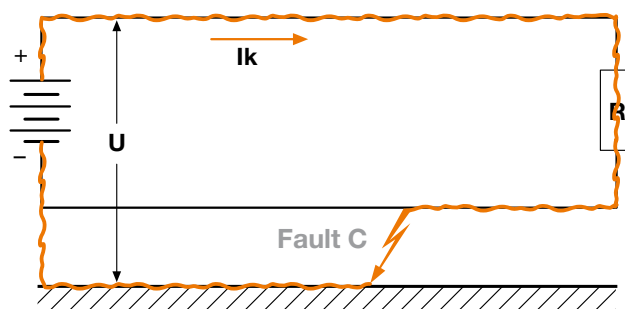
Fault B:

the fault on the non-earthed polarity sets up a current involving the overcurrent protections as a function of the soil resistance.



Fault C:

the fault on the earthed polarity sets up a current which affects the overcurrent protections as a function of the soil resistance; such current presents an extremely low value because it depends on the impedance of the soil and the U is next to zero (since the voltage drop on the load further reduces its value).



Conclusions

with this typology of network, the fault type which affects the version of the CB and the connection of the poles is fault A (between the two polarities), but it is necessary to take into consideration also the fault between the non-earthed polarity and the earth itself (fault B) since, as described above, a current (with the value depending also by the impedance of the soil and consequently difficult to assess) could flow at full voltage; for this reason, all the CB poles necessary for protection shall be connected in series on the non-earthed polarity.

6.3 Network with the middle point of the supply source connected to earth

This typology of network is obtained by connecting the middle point of the battery to earth.

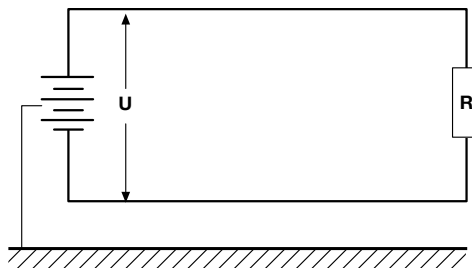
This type of connection reduces the value of static over-

voltages, which otherwise could be present at full voltage in an insulated plant.

The main disadvantage of this connection, if compared with other types, is that a fault between a polarity, both a negative as well a positive one, and earth gives rise to a fault current at a voltage $\frac{U}{2}$.

Common solution

Figure 15 Network with the middle point connected to earth



Representation in compliance with Std. IEC 60364-1*

Figure 16 TT d.c. distribution system

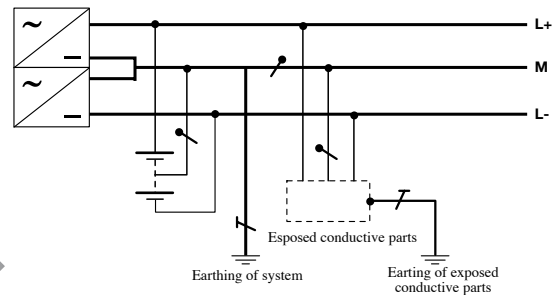
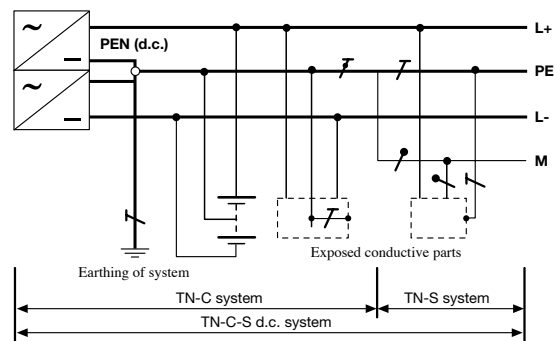


Figure 17 TN-C-S d.c. distribution system

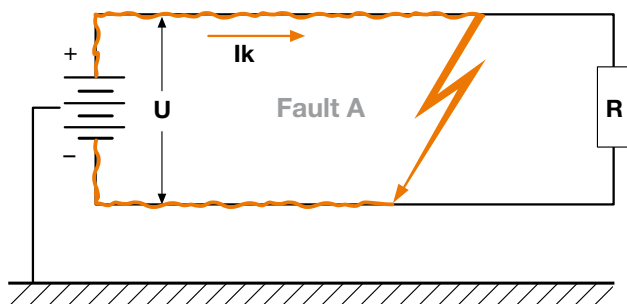


*such analogy is valid for the earthing of the supply source only and not for the earthing of the exposed-conductive-parts; besides, as far as the prescriptions concerning indirect contacts are concerned, please refer to Std. IEC 60364-4.

Fault typologies in a network with the middle point connected to earth

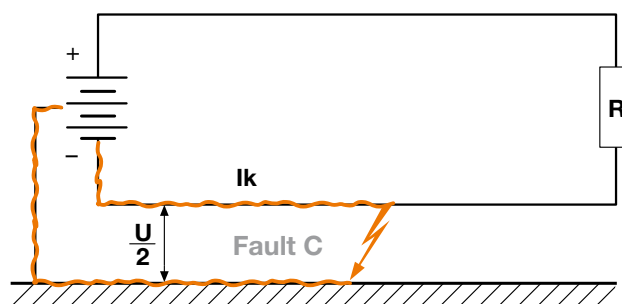
Fault A:

the fault between the two polarities is a short-circuit current fed by the full voltage U . The breaking capacity of the circuit-breaker shall be chosen according to the short-circuit current relevant to such fault.



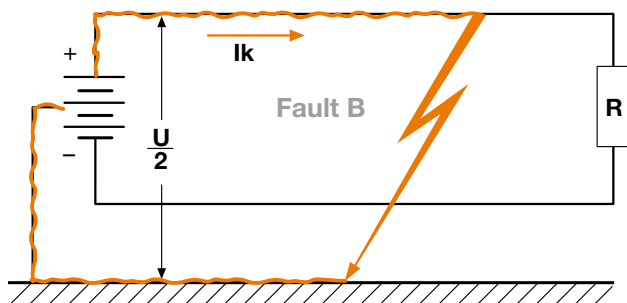
Fault C:

in this case, the fault is analogous to the previous case, but it concerns the negative polarity.



Fault B:

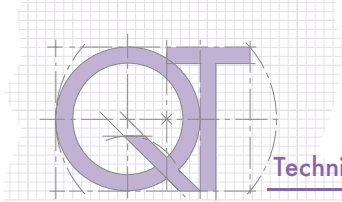
the fault between the polarity and earth sets up a short-circuit current lower than that relevant to the fault between the two polarities, since it is supplied by a voltage equal to $\frac{U}{2}$ depending on the soil resistance.



Conclusions

with this typology of network the fault which affects the version of the CB and the connection of the poles is fault A (between the two polarities); however, also the fault between a polarity and earth (with reference to the above diagrams) should be taken into consideration because, as previously described, a current (the value of which depends also on the impedance of the soil) could flow at a voltage equal to $\frac{U}{2}$.

In a network with the middle point of the supply connected to earth, the circuit-breaker must be inserted necessarily on both the polarities.



7 Choice of the protective device

For the correct dimensioning of a circuit-breaker in a direct current network, some electrical parameters which characterize the device itself must be evaluated.

Here is a short description of these parameters, which are mentioned in the following pages.

Rated operational voltage U_e

It represents the value of voltage which determines the application of the equipment and to which all the other parameters typical of the equipment are referred.

Rated uninterrupted current I_u

It represents the value of current which the equipment can carry for a indefinite time (uninterrupted duty). This parameter is used to define the size of the circuit-breaker.

Rated current I_n

It represents the value of current which characterizes the protection trip unit mounted on the circuit-breaker and determines the protection characteristic of the circuit-breaker itself according to the available settings of the trip unit.

This current is often referred to the rated current of the load protected by the circuit-breaker itself.

Rated ultimate short-circuit breaking capacity I_{cu}

The rated ultimate short-circuit breaking capacity of a circuit-breaker is the maximum short-circuit current value which the circuit-breaker can break twice (in accordance with the sequence O - t - CO) at the corresponding rated operational voltage. After the opening and closing sequence the circuit-breaker is not required to carry its rated current.

Rated service short-circuit breaking capacity I_{cs}

The rated service short-circuit breaking capacity of a circuit-breaker is the maximum short-circuit current value which the circuit-breaker can break three times in accordance with a sequence of opening and closing operations (O - t - CO - t - CO) at a defined rated operational voltage (U_e) and at a defined time constant (for direct current). After this sequence the circuit-breaker is required to carry its rated current.

Rated short-time withstand current I_{cw}

The rated short-time withstand current is the current that the circuit-breaker in the closed position can carry during a specified short time under prescribed conditions of use and behaviour; the circuit-breaker shall be able to carry this current during the associated short-time delay in order to ensure discrimination between the circuit-breakers in series.

Rating plates of the circuit-breakers

SACE Tmax XT molded-case circuit-breakers for direct current

CIRCUIT-BREAKER TYPE			
Series XT	Size 1 2 3 4	Rated ultimate short-circuit breaking capacity at 250 Vd.c. (with 2 poles in series) B = 18 kA (XT1) C = 25 kA (XT1) N = 36 kA S = 50 kA H = 70 kA L = 85 kA (XT2-XT4) V = 100 kA (XT2-XT4)	Size 160 A 250 A

Tmax XT1B 160	Ue=690V AC/500V DC Ui=800V Uimp=8kV				S/N: _____
Ue (V)	230	415	525	690	250
Icu (kA)	25	18	6	3	18
Ics (% Icu)	100	100	100	100	100
Cat A	~ 50-60Hz			--- 2P in series	

ABB SACE Tmax XT1B 160 IEC 60947-2 ABB SACE Italy

on off In = 160A TEST

Compliance with the International Standard IEC60947-2: "Low-voltage switchgear and controlgear - Circuit-Breakers"

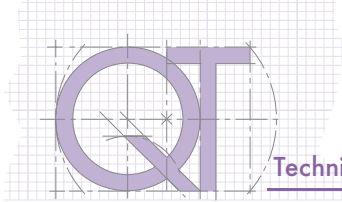
CE marking affixed on ABB circuit-breakers to indicate compliance with the following CE directives:
 -"Low Voltage Directive" (2006/95/EC)
 -"Electromagnetic Compatibility Directive" (2004/108/EC)

Rated ultimate short-circuit breaking capacity (**Icu**) and rated service short-circuit breaking capacity (**Ics**)

According to the international Standard IEC 60947-2, the circuit-breakers can be divided into:

- **category A**, i.e. circuit-breakers without a specified short-time withstand current rating;
- **category B**, i.e. circuit-breakers with a specified short-time withstand current rating

In Rated current



Moulded-case circuit-breaker: Tmax T

CIRCUIT-BREAKER TYPE			
Series T	Size 1 2 3 4 5 6	Rated ultimate short-circuit breaking capacity at 250 Vd.c. (with 2 poles in series) N = 36 kA S = 50 kA H = 70 kA L = 85 kA (for T2) L = 100 kA V = 150 kA	Rated uninterrupted current 160 A 250 A 320 A 400 A 630 A 800 A

Rated operational voltage	Rated ultimate short-circuit breaking capacity (Icu) and rated service short-circuit breaking capacity (Ics)	Rated uninterrupted current	Rated insulation voltage	Rated impulse withstand voltage	Compliance with the International Standard IEC60947-2: "Low-voltage switchgear and controlgear - Circuit-Breakers"																																									
<table border="1"> <tr> <td>Tmax T2L 160</td> <td>Iu=160A</td> <td>Ue=690V</td> <td>Ui=800V</td> <td>Uimp=8kV</td> <td>IEC 60947-2</td> </tr> <tr> <td>Ue (V)</td> <td>230</td> <td>400/415</td> <td>440</td> <td>500</td> <td>690</td> <td>250</td> <td>500</td> <td>Made in Italy by ABB SACE</td> </tr> <tr> <td>Icu (kA)</td> <td>150</td> <td>85</td> <td>75</td> <td>50</td> <td>10</td> <td>85</td> <td>85</td> <td rowspan="2"> </td> </tr> <tr> <td>Ics (% Icu)</td> <td>75</td> <td>75</td> <td>75</td> <td>75</td> <td>75</td> <td>75</td> <td>75</td> </tr> <tr> <td>Cat A</td> <td colspan="4">~ 50-60Hz</td> <td colspan="2">2 P. --- 3 P in series</td> <td colspan="2"></td> </tr> </table>						Tmax T2L 160	Iu=160A	Ue=690V	Ui=800V	Uimp=8kV	IEC 60947-2	Ue (V)	230	400/415	440	500	690	250	500	Made in Italy by ABB SACE	Icu (kA)	150	85	75	50	10	85	85		Ics (% Icu)	75	75	75	75	75	75	75	Cat A	~ 50-60Hz				2 P. --- 3 P in series			
Tmax T2L 160	Iu=160A	Ue=690V	Ui=800V	Uimp=8kV	IEC 60947-2																																									
Ue (V)	230	400/415	440	500	690	250	500	Made in Italy by ABB SACE																																						
Icu (kA)	150	85	75	50	10	85	85																																							
Ics (% Icu)	75	75	75	75	75	75	75																																							
Cat A	~ 50-60Hz				2 P. --- 3 P in series																																									
<p>Part relevant to direct current according to the number of poles connected in series called to extinguish the fault current the rated operational voltage and the breaking capacities (Icu and Ics) are indicated</p> <p>According to the international Standard IEC 60947-2, the circuit-breakers can be divided into:</p> <ul style="list-style-type: none"> - category A, i.e. circuit-breakers without a specified short-time withstand current rating; - category B, i.e. circuit-breakers with a specified short-time withstand current rating <p>CE marking affixed on ABB circuit-breakers to indicate compliance with the following CE directives:</p> <ul style="list-style-type: none"> - "Low Voltage Directive" (2006/95/EC) - "Electromagnetic Compatibility Directive" (2004/108/EC) 																																														

Emax air circuit-breakers for direct current

CIRCUIT-BREAKER TYPE			
Series	Size	Rated ultimate short-circuit breaking capacity at 500 Vd.c.	Rated uninterrupted current
E	2	B = 35 kA (E2) N = 50 kA (E2) N = 60 kA (E3) S = 75 kA (E4) H = 65 kA (E3) H = 100 kA (E4-E6)	800 A
	3		1000 A
	4		1250 A
	6		1600 A


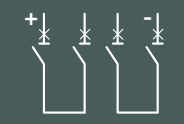


Rated ultimate short-circuit breaking capacity (**I_{cu}**) and rated service short-circuit breaking capacity (**I_{cs}**)

Rated operational voltage (**U_e**)

Rated short-time withstand current (**I_{cw}**)

Rated uninterrupted current

International Standard IEC60947-2: "Low voltage switchgear and controlgear - Circuit-breakers"

SACE E2B 800		I_u=800A U_e=1000V			Upper supply	
U_e (V)		500	750	1000	IEC 60947-2 U _{imp} = 12kW	
I_{cu}=I_{cs} (kA)		35	25	25	ABB-SACE Italy 	
I_{cw}(0.5s) (kA)		35	25	25		
Cat B		4P 				

Connection modality to the circuit-breaker poles: the connection in series shown in the scheme is carried out in the factory by ABB SACE

According to the international Standard IEC 60947-2, the circuit-breakers can be divided into:

- **category A**, i.e. circuit-breakers without a specified short-time withstand current rating;
- **category B**, i.e. circuit-breakers with a specified short-time withstand current rating.

CE marking affixed on ABB circuit-breakers to indicate compliance with the following CE directives:

- "Low Voltage Directive" (2006/95/EC)
- "Electromagnetic Compatibility Directive" (2004/108/EC)

Dimensioning of circuit-breakers

In the previous pages the main electrical characteristics of a circuit-breaker have been defined, which are necessary for a correct choice of the circuit-breaker so that protection of the plant is guaranteed.

To proceed with the dimensioning it is necessary to know the following characteristics of the network:

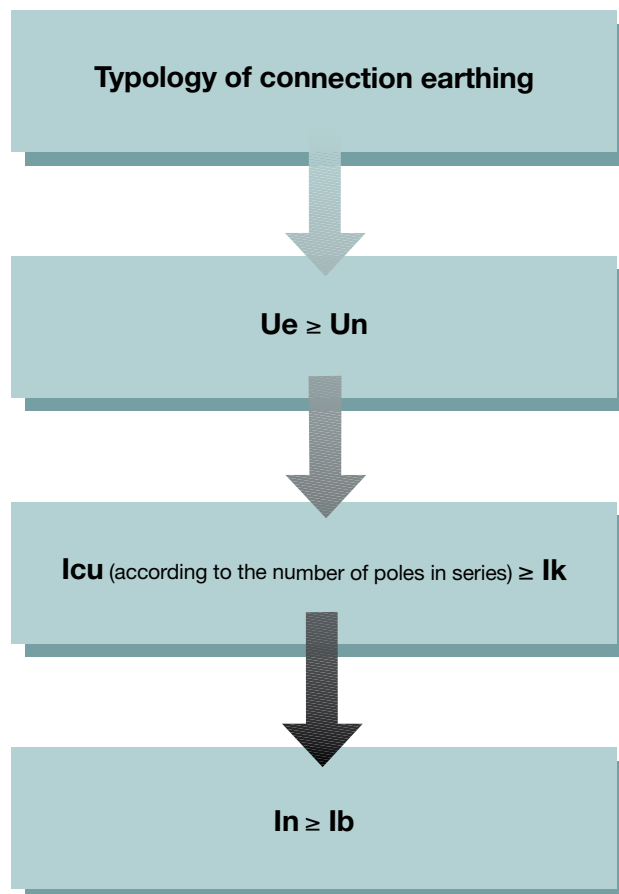
- the type of network (see Chapter 6) to define the connection of the circuit-breaker poles according to the possible fault conditions;
- the rated voltage of a plant (U_n) to define the operational voltage (U_e) depending on the pole connection by verifying the relation: $U_n \leq U_e$;
- the short-circuit current at the installation point of the circuit-breaker (I_k) to define the circuit-breaker version (depending on the connection of the poles) by verifying

the relation $I_k \leq I_{cu}$ (at the reference rated operational voltages U_e);

- the rated current absorbed by the load (I_b) to define the rated current (I_n) of the thermal-magnetic trip unit or of the new d.c. electronic release (PR122-PR123/DC for Emax) by verifying the relation $I_b \leq I_n$.

Procedures to guarantee the correct dimensioning of a circuit-breaker

The following diagram summarizes schematically the choices to be carried out for a correct dimensioning of the circuit-breaker in relation to the characteristics of the plant.



The values given in the following tables indicate the performances of circuit-breakers under the heaviest fault conditions which characterize the typology of network under consideration (see Chapter 6: “Typologies of d.c. networks”); the prescribed connections shall be carried out by the customer. As regards the electrical characteristics of the mentioned circuit-breakers see Chapter 9 “ABB offer”.

Table 1-2 Connection modality of poles (for MCBs type S280 UC-S800S UC) in an insulated network

INSULATED NETWORK			
Rated voltage (Un)		≤ 500	≤ 750
Protection + isolation function			
S800S UC	In = 10...125 A	50	50

INSULATED NETWORK		
Rated voltage (Un)		≤ 440
Protection + isolation function		
S280 UC	In = 0,5...2 A	50
	In = 3...40 A	6
	In = 50...63 A	4,5

Table 3-4 Connection modality of poles (for MCBs type S280 UC-S800S UC) in a network with one polarity earthed

NETWORK WITH ONE POLARITY EARTHED				
Rated voltage (Un)		≤ 250	≤ 500	≤ 750
Protection function				
S800S UC	In = 10...125 A	50	50	50

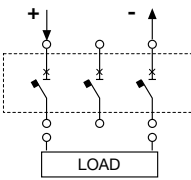
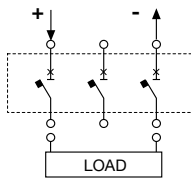
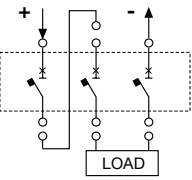
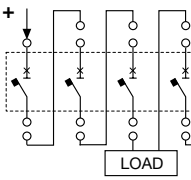
NETWORK WITH ONE POLARITY EARTHED				
Rated voltage (Un)		≤ 220		≤ 440
Protection function				
Protection + isolation function				
S280 UC	In = 0,5...2 A	50	50	50
	In = 3...40 A	6	10	6
	In = 50...63 A	4,5	6	4,5

Table 5-6 Connection modality of poles (for MCBs type S280 UC) in a network with the middle point earthed

NETWORK WITH THE MIDDLE POINT CONNECTED TO EARTH		
Rated voltage (Un)		≤ 220
Protection + isolation function		
S280 UC	In = 0,5...2 A	50
	In = 3...40 A	10
	In = 50...63 A	6

NETWORK WITH THE MIDDLE POINT CONNECTED TO EARTH		
Rated voltage (Un)		≤ 500
Protection + isolation function		
S800S UC	In = 10...125 A	50

Table 7 Connection modality of poles (for MCCBs type SACE Tmax XT) in an insulated network*

			INSULATED NETWORK			
Rated voltage (Un)		≤ 250	≤ 500			
Protection + isolation function						
XT1 160	B	18			18	
	C	25			25	
	N	36			36	
	S	50			50	
	H	70			70	
XT2 160	N	36			36	
	S	50			50	
	H	70			70	
	L	85			85	
	V	100			100	
XT3 250	N	36	36			
	S	50	50			
XT4 160/250	N	36	36			
	S	50	50			
	H	70	70			
	L	85	85			
	V	100	100			

The positive pole (+) can be inverted with the negative pole (-).

* with these typologies of pole connection the possibility of a double fault to earth is considered unlikely (see Chapter 6: "Typologies of d.c. networks")

for higher voltages, ask ABB

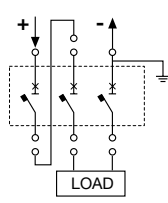
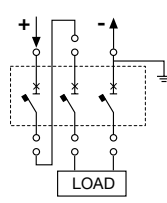
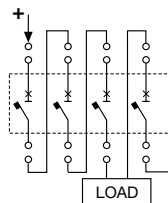

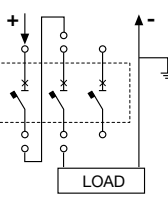
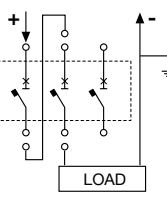
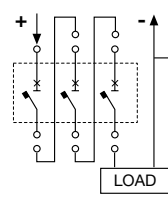
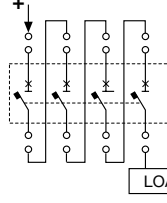
Table 8 Connection modality of poles (for MCCBs type Tmax) in a insulated network*

		INSULATED NETWORK						
Rated voltage (Un)		≤ 250		≤ 500		≤ 750		
Protection + isolation function								
T1 160	B	16	20		16			
	C	25	30		25			
	N	36	40		36			
T2 160	B	16	20		16			
	C	25	30		25			
	N	36	40		36			
	S	50	55		50			
	H	70	85		70			
T3 250	N	36	40		36			
	S	50	55		50			
T4 250/320	N	36		25		16		
	S	50		36		25		
	H	70		50		36		
T5 400/630	L	100		70		50		
	V	150		100		70		
T6 630/800	N	36		20		16		
	S	50		35		20		
	H	70		50		36		
	L	100		65		50		

The positive pole (+) can be inverted with the negative pole (-).

* with these typologies of pole connection the possibility of a double fault to earth is considered unlikely (see Chapter 6: "Typologies of d.c. networks")

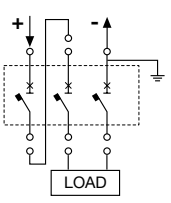
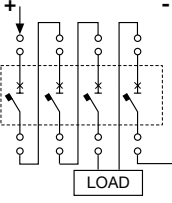
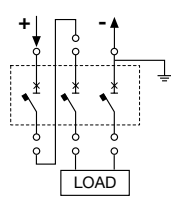
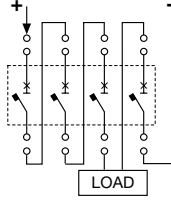
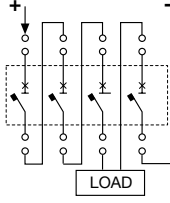

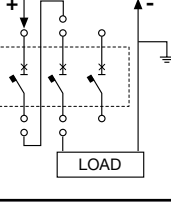
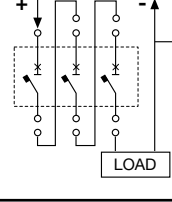
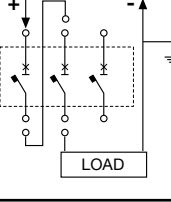
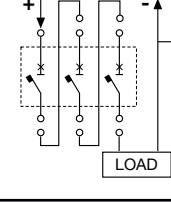
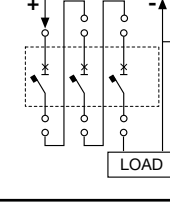

Table 9 Connection modality of poles (for MCCBs type SACE Tmax XT) in a network with one polarity earthed (in the considered connections, the earthed polarity is the negative one)

			NETWORK WITH ONE POLARITY EARTHED			
Rated voltage (Un)		≤ 250	≤ 500			
Protection + isolation function						
Protection function						
XT1 160	B	18				18
	C	25				25
	N	36				36
	S	50				50
	H	70				70
XT2 160	N	36				36
	S	50				50
	H	70				70
	L	85				85
	V	100				100
XT3 250	N	36	36			
	S	50	50			
XT4 160/250	N	36	36			
	S	50	50			
	H	70	70			
	L	85	85			
	V	100	100			

* earthing shall be carried out on the supply side of the circuit-breakers

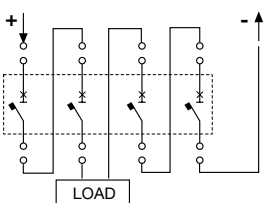
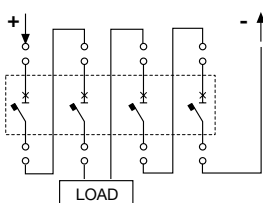
for higher voltages, ask ABB

Table 10 Connection modality of poles (for MCCBs type Tmax) in a network with one polarity earthed (in the considered connections, the earthed polarity is the negative one)

		NETWORK WITH ONE POLARITY EARTHED					
Rated voltage (Un)		≤ 250		≤ 500		≤ 750	
Protection + isolation function							
Protection function							
T1 160	B	16	20		16		
	C	25	30		25		
	N	36	40		36		
T2 160	B	16	20		16		
	C	25	30		25		
	N	36	40		36		
	S	50	55		50		
	H	70	85		70		
T3 250	N	36	40		36		
	S	50	55		50		
T4 250/320	N	36		25	16		
	S	50		36	25		
	H	70		50	36		
T5 400/630	L	100		70	50		
	V	150		100	70		
	N	36		20	16		
T6 630/800	S	50		35	20		
	H	70		50	36		
	L	100		65	50		

* earthing shall be carried out on the supply side of the circuit-breakers

Table 11 Connection modality of poles (for MCCBs type SACE Tmax XT) in a network with the middle point earthed

NETWORK WITH THE MID-POINT EARTHED			
Rated voltage (Un)	≤ 250	≤ 500	
Protection + isolation function			
XT1 160	B	18	18
	C	25	25
	N	36	36
	S	50	50
	H	70	70
XT2 160	N	36	36
	S	50	50
	H	70	70
	L	85	85
	V	100	100
XT3 250	N	36	36
	S	50	50
XT4 160/250	N	36	36
	S	50	50
	H	70	70
	L	85	85
	V	100	100

for higher voltage ask ABB

Table 12 Connection modality of poles (for MCCBs type Tmax T) in a network with the middle point earthed

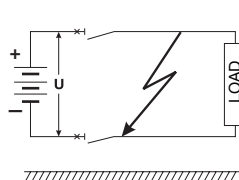
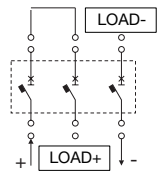
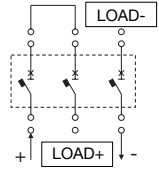
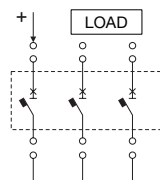
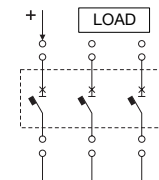
		NETWORK WITH THE MID-POINT EARTHED		
Rated voltage (Un)		≤ 250*	≤ 500**	≤ 750
Protection + isolation function				
T1 160	B	20	16	
	C	30	25	
	N	40	36	
T2 160	B	20	16	
	C	30	25	
	N	40	36	
	S	55	50	
	H	85	70	
	L	100	85	
T3 250	N	40	36	
	S	55	50	
T4 250/320	N	36	25	
	S	50	36	25
	H	70	50	36
T5 400/630	L	100	70	50
	V	100	100	70
T6 630/800	N	36	20	16
	S	50	35	20
	H	70	50	36
	L	100	65	50

* for the use of three-phase circuit-breakers please ask ABB

** for the use of three-phase circuit-breakers (T4-T5-T6) please ask ABB

The values given in the following tables indicate the performances of circuit-breakers under the heaviest fault conditions which characterize the typology of network under consideration (see Chapter 6: “Typologies of networks”); the connections prescribed in the table (carried out in the factory by ABB SACE) refer to Emax air circuit-breakers equipped with the new d.c. electronic trip unit type PR122/PR123 DC. As regards the electrical characteristics of the mentioned circuit-breakers see Chapter 9 “ABB offer”.

Table 13 Connection modality of poles for (ACBs type Emax) in an insulated network

				INSULATED NETWORK ⁽¹⁾			
Rated voltage (Un)			≤ 500	≤ 750	≤ 1000		
							
Isolation			■	■	■	■	
Protection			■	■	■	■	
PR122/DC			■	■	■	■	
PR123/DC			■	■	■	■	
Icu ⁽²⁾			(kA)	(kA)	(kA)	(kA)	
E2	B	800	35	25	25	25	
		1000					
		1250					
		1600					
	N	1600	50	25	40	25	
E3	N	800	60	40	50	35	
		1000					
		1250					
		1600					
		2000					
	H	1600	65 ⁽³⁾	40	50	40	
		2000					
2500							
E4	S	1600	75	65	65	50	
		2000					
		2500					
	H	3200	100	65	65	65	
E6	H	3200	100	65	65	65	
		4000					
		5000					

⁽¹⁾ the possibility of a double earth fault is considered negligible with this type of pole connections.

⁽²⁾ Icu with L/R = 15ms according to IEC 60946-2 Standard. For Icu with L/R = 5ms and L/R = 30ms, ask ABB.

⁽³⁾ 85kA only if supplied from lower terminals.

Table 14 Connection modality of poles for (ACBs type Emax) in a network with one polarity earthed (in the considered connections, the earthed polarity is the negative one)

Rated voltage (Un)		NETWORK WITH EARTHED NEGATIVE POLARITY ⁽¹⁾								
		≤ 500 ⁽²⁾								
Isolation		■		■						
Protection		■		■						
PR122/DC		■		■						
PR123/DC		■		■						
Type of fault		a		b						
Poles in series affected by the fault		3		4						
Icu ⁽³⁾		(kA)		(kA)						
E2	B	800	35	20	35	35				
		1000								
1250										
1600										
E3	N	1600	60	30	60	60				
		2000								
2500										
H		1600					65 ⁽⁴⁾	40	65 ⁽⁴⁾	65 ⁽⁴⁾
		2000								
	2500									
E4	S	1600	75	50	75	75				
		2000								
		2500								
		3200								
E6	H	3200	100	65	100	100				
		4000								
		5000								

(1) for networks with positive earthed polarity, ask ABB.

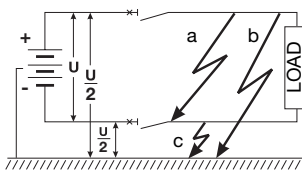
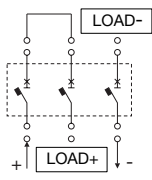
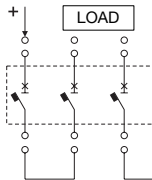
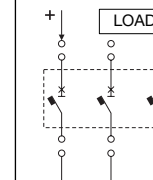
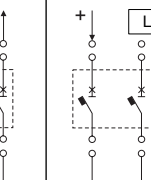
(2) for higher voltages, ask ABB.

(3) Icu with L/R = 15ms according to IEC 60946-2 Standard. For Icu with L/R = 5ms and L/R = 30ms, ask ABB.

(4) 85kA only if supplied from lower terminals.

Earthing shall be carried out on the supply side of the circuit-breaker.

Table 15 Connection modality of poles for (ACBs type Emax) in a network with the middle point earthed

NETWORK WITH THE MID-POINT EARTHED														
Rated voltage (Ue)		≤ 500			≤ 500			≤ 750			≤ 1000			
														
PR122/DC		-			-			-			-			
PR123/DC		■			■			■			■			
Type of fault		a	b	c	a	b	c	a	b	c	a	b	c	
Poles in series affected by the fault		3	2 (U/2)	1 (U/2)	4	2 (U/2)	2 (U/2)	4	2 (U/2)	2 (U/2)	4	2 (U/2)	2 (U/2)	
Icu ⁽¹⁾		kA			kA			kA			kA			
E2	B	800	35	35	18	35	35	35	25	25	25	25	25	25
		1000												
		1250												
N	1600	50	50	25	50	50	50	40	40	40	25	25	25	
	2000	60	60	30	60	60	60	50	50	50	35	35	35	
	2500													
H	1600	65 ⁽²⁾	65	40	65 ⁽²⁾	65 ⁽²⁾	65 ⁽²⁾	50	50	50	40	40	40	
	2000													
	2500													
E4	S	1600	75	75	35	75	75	75	65	65	65	50	50	50
		2000												
		2500												
		3200												
H	3200	100	100	50	100	100	100	65	65	65	65	65	65	
E6	H	3200	100	100	65	100	100	100	65	65	65	65	65	65
		4000												
		5000												

⁽¹⁾ Icu with L/R = 15ms according to IEC 60946-2 Standard. For Icu with L/R = 5ms and L/R = 30ms, ask ABB.

⁽²⁾ 85kA only if supplied from below

The following tables show the pole connections of Tmax T, SACE Tmax XT and Emax switch-disconnectors according to the installation voltage; the connections shown in the table shall be carried out by the customer.

Table 16 Connection modality of poles for SACE Tmax XT switch-disconnectors

Rated voltage (Un)	≤ 250	≤ 500
Pole connection		
XT1D 160	■	■
XT3D 250	■	■
XT4D 250	■	■

Table 17 Connection modality of poles for Tmax T switch-disconnectors

Rated voltage (Un)	≤ 250	≤ 500		≤ 750
Pole connection				
T1D 160	■	-	■	-
T3D 250	■	-	■	-
T4D 250/320	■	■	-	■
T5D 400/630	■	■	-	■
T6D 630/800/1000	■	■	-	■
T7D 1000/1250/1600	■	■	■	■

Table 18 Connection modality of poles for Emax switch-disconnectors

Rated voltage (Un)	≤ 500	≤ 750	≤ 1000	
Pole connection				
X1-E1...E6 / MS	■	-	-	-
E1...E6 E/ MS	■	■	■	■

Choice of a molded-case circuit-breaker type SACE Tmax XT

Example

Characteristics of the plant:

- **Type of network:** one polarity earthed (the negative one)
- **Network voltage:** $U_n = 250\text{Vd.c.}$
- **Rated voltage absorbed by the loads (I_b):** 180A
- **Short-circuit current:** 40kA

Choice of the circuit-breaker

Making reference to the indications given on page 23, to proceed with a correct dimensioning of the circuit-breaker the following prescriptions must be complied with:

- $U_e \geq U_n$
- $I_{cu} \geq I_k$
- $I_n \geq I_b$

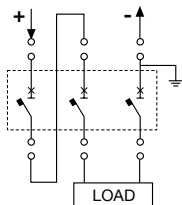
With reference to the type of network, the suitable table shall be identified among the tables 7-9-11; in this case the table relevant to a network with one polarity earthed (Table 9) shall be chosen.

The column with the performances referred to a network voltage $U_n \leq 250\text{V}$.

The load current is the reference necessary to identify the row of the table referred to the circuit-breakers with uninterrupted rated current I_u higher than or equal to the load current; in the case considered as example a circuit-breaker type SACE Tmax XT3 with $I_n=200\text{A}$ can be used.

The version (N-S) is chosen according to the relation $I_{cu} \geq I_k$. In this example, since $I_k=40\text{kA}$, version S can be used.

With these bonds limiting the choice, two possible schemes for the pole connection can be identified and assuming that also the earthed polarity is to be disconnected the connection scheme to be used is the following:



Among the rated currents available for the thermomagnetic trip units of the circuit-breaker SACE Tmax XT3 250, that with $I_n=200\text{A}$ shall be chosen; therefore, to summarize, a three-pole thermomagnetic circuit-breaker XT3 250 TMD 200 shall be used connected as shown in the figure, i.e. with two poles in series on the polarity insulated from earth and the other one connected on the earthed polarity.

Choice of a an air circuit-breaker type Emax

Example

Characteristics of the plant:

- **Type of network:** insulated
- **Network voltage:** $U_n = 500\text{Vd.c.}$
- **Rated voltage absorbed by the loads (I_b):** 1800A
- **Short-circuit current:** 45kA

Choice of the circuit-breaker

Making reference to the indications given on page 23, to proceed with a correct dimensioning of the circuit-breaker the following prescriptions must be complied with:

- $U_e \geq U_n$
- $I_{cu} \geq I_k$
- $I_n \geq I_b$

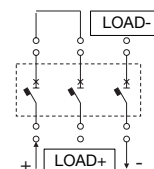
With reference to the type of network, the suitable table shall be identified among the tables 13-14-15; in this case the table relevant to an insulated network (Table 13) shall be chosen.

The column with the performances referred to a network voltage $U_n \leq 500\text{Vd.c.}$

From the column considered, the circuit-breaker which would seem suitable for its performances under short-circuit conditions is the CB type E2N ($N=50\text{kA} > I_k$), but according to the table relevant to the rated uninterrupted current (page 47) it is necessary to pass to a CB type E3N since it has $I_u=2000\text{A}$ (this value corresponds to the I_n of the trip unit), value higher than the current absorbed by the loads; in this way, the third relationship is complied with.

Therefore the suitable circuit-breaker is a three-pole circuit-breaker type E3N 2000 with PR122-123/DC $I_n=2000\text{A}$ (the connection of the poles is carried out in the factory by ABB SACE).

The solution of the table shows the connections between three-pole circuit-breaker, load and supply source.



8 Use of alternating current equipment in direct current

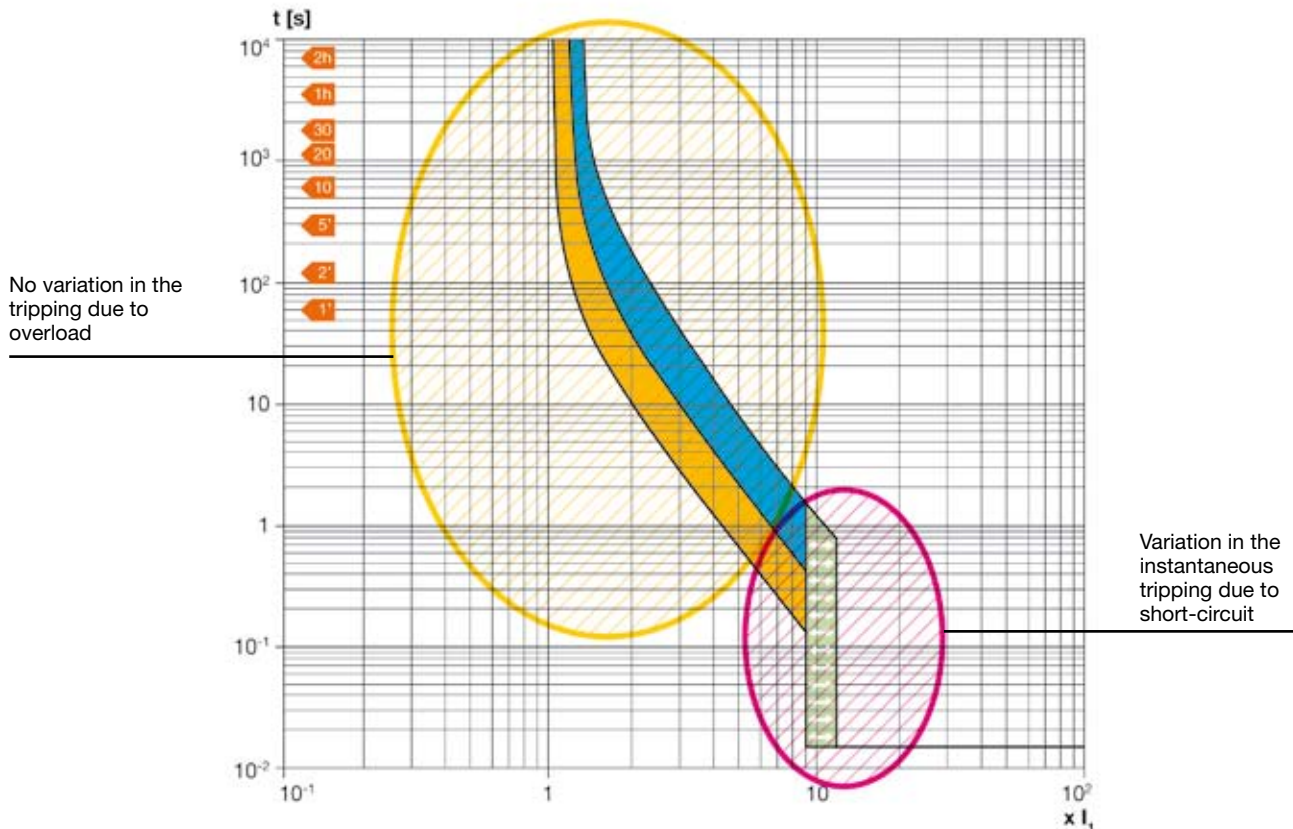
8.1 Variation of the magnetic tripping

The thermal magnetic trip units fitted to a.c. circuit-breakers are also suitable to be used with direct current.

The part relevant to the thermal protection does not change with reference to its tripping characteristic since the bimetal strips of the trip units are influenced by the heating caused by the current flow, it does not matter whether alternating or direct: in fact the bimetal strips are sensitive to the r.m.s. value.

As regards the instantaneous protection against short-cir-

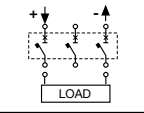
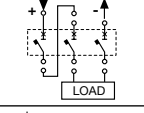
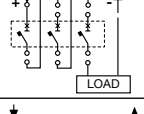
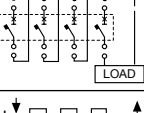
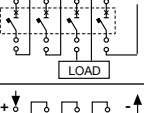
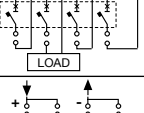
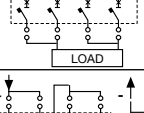
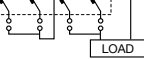
cuit, due to ferromagnetic phenomena, the instantaneous tripping occurs at a different value in comparison with the analogous case in alternating current (the green area in the figure shows the shifting of the magnetic tripping). A coefficient, called k_m , variable as a function of the circuit-breaker and of the connection type of its poles, allows to derive the d.c. instantaneous trip threshold starting from the relevant value in alternating current; therefore, this coefficient is to be applied to the threshold I_3 .



On the contrary, there is no derating for Emax series circuit-breakers equipped with the new d.c. electronic releases type PR122-PR123/DC because the trip times comply with the curve set on the electronic trip unit. The following table reports the coefficient km according

to the circuit-breaker type and to the connection modality of the poles (the given diagrams are valid for all typologies of networks because the coefficient km depends exclusively on the circuit-breakers characteristics).

Table 19 Coefficient km according to the connection modality of the CB poles

Connection modality	Circuit-breaker									
	XT1	XT2	XT3	XT4	T1	T2	T3	T4	T5	T6
	1.3	1.3	1.3	1.3	1.3	1.3	1.3	1.3	1.1	1.1
	1	1.15	1.15	1.15	1	1.15	1.15	1.15	1	1
	1	1.15	1.15	1.15	1	1.15	1.15	1.15	1	1
	-	-	-	-	-	-	-	1	0.9	0.9
	-	-	-	-	-	-	-	1	0.9	0.9
	-	-	-	-	-	-	-	1	0.9	0.9
	-	-	-	-	-	-	-	-	-	1
	-	-	-	-	-	-	-	-	-	0.9

Example

With a circuit-breaker type XT2N 160 TMA In=160 (with I3=10xIn) and choosing a pole connection corresponding to the first figure of Table 19, it is possible to visualize the coefficient km equal to 1.3; the d.c. magnetic tripping shall be equal to:

$$I_3 = 10 \times I_n \times k_m = 10 \times 160 \times 1.3 = 2080 \text{ A} \quad (\pm 20\% \text{ tolerance})$$

8.2 Connection of the CB poles in parallel

Molded-case circuit-breakers of series Tmax equipped with thermal magnetic trip units can be used both for alternating current as well as for direct current; when used for d.c. applications, they are available for rated current from 1.6A (XT2 CBs) up to 800A (T6 CBs).

For applications where higher currents are required, it is possible to connect the CB poles in parallel, so that the required current carrying capacity can be obtained.

When choosing a circuit-breaker, it is necessary to consider the fact that the connection of the poles in parallel involves, in addition to the variation of the magnetic tripping, also a derating to be applied to the rated current of the trip unit; such derating varies based on the number of poles connected in parallel.

The following table reports the correction factors for the pole connected in parallel (when using a 4-pole circuit-breaker the neutral conductor shall be always at 100%):

	number of poles in parallel		
	2	3	4 (neutral at 100%)
derating coefficient	0.9	0,8	0,7

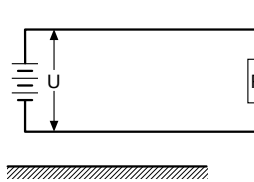
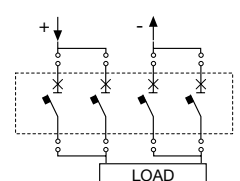
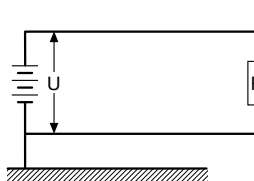
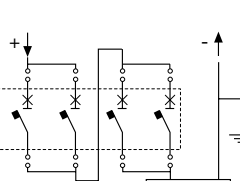
For example, by using a circuit-breaker type T6N 800 and connecting two poles in parallel for each polarity, the rated uninterrupted current shall be equal to:

$$I_n = I_n \times n^{\circ}_{\text{no.of poles in parallel}} \times K = 800 \times 2 \times 0.9 = 1440 \text{ A}$$

However, it is necessary to take into consideration the likely fault typologies in relation to the earthing arrangement of the plant.

ABB SACE advises against the connection in parallel, since it results quite difficult to realize a connection which can guarantee that the currents flowing in the CB poles are perfectly balanced. Therefore, for rated operational currents exceeding 800 A, the use of air circuit-breakers of Emax series equipped with electronic releases type PR122 - PR123/DC is suggested.

The following table shows the connections of poles in parallel with the relevant derating and performances under short-circuit conditions referred to the adopted network typology:

type of network	connection of the poles in parallel	electrical characteristics
<p>insulated network</p> 		<p>To obtain such connection it is necessary to use a four-pole circuit-breaker with the neutral conductor at 100%.</p> <p>With a CB type T6 800, the available settings are:</p> <ul style="list-style-type: none"> - maximum line current = 1440 A - instantaneous tripping = 14400 A (±20% tolerance) <p>This application can be obtained with an installation voltage not exceeding 500Vd.c.</p> <p>The breaking capacities are (according to the different versions):</p> <p>N= 36kA with Un< 250Vd.c. - 20kA with Un< 500Vd.c. S= 50kA with Un< 250Vd.c. - 35kA with Un< 500Vd.c. H= 70kA with Un< 250Vd.c. - 50kA with Un< 500Vd.c. L= 100kA with Un< 250Vd.c. - 65kA with Un< 500Vd.c.</p>
<p>network with one polarity earthed</p> 	<p>protection function without insulation function</p> 	<p>To obtain such connection it is necessary to use a four-pole circuit-breaker with the neutral conductor at 100%.</p> <p>With a CB type T6 800, the available settings are:</p> <ul style="list-style-type: none"> - maximum line current = 1440 A - instantaneous tripping = 12960 A (±20% tolerance) <p>This application can be obtained with an installation voltage not exceeding 500Vd.c.</p> <p>The breaking capacities are (according to the different versions):</p> <p>N= 36kA with Un< 250Vd.c. - 20kA with Un< 500Vd.c. S= 50kA with Un< 250Vd.c. - 35kA with Un< 500Vd.c. H= 70kA with Un< 250Vd.c. - 50kA with Un< 500Vd.c. L= 100kA with Un< 250Vd.c. - 65kA with Un< 500Vd.c.</p>

9 ABB offer

9.1 Automatic circuit-breakers

ABB SACE offers the following range of products for the protection and disconnection of d.c. networks.

Automatic circuit-breakers

Automatic circuit-breakers, that are devices carrying out the protection function against overcurrents, are divided into three families:

Miniature circuit-breakers

For the use in direct current, both miniature circuit-breakers series S280 UC as well as series S800S UC and S800 PV are available

Miniature circuit-breakers series S280 UC comply with Standard IEC 60947-2 and differ from the standard versions in that they are equipped with permanent magnetic elements on the internal arcing chambers. Such elements allow the electric arc to be broken up to voltages equal to 484 Vd.c.

The presence of these permanent magnetic elements establishes the circuit-breaker polarity (positive or negative); as a consequence, their connection shall be carried out in compliance with the polarity indicated on the circuit-breakers.

An incorrect connection of the polarities could damage the circuit-breaker.

Circuit-breakers series S280 UC, special version for d.c. applications, are available with characteristics B, C, K and Z.

As regards the connection modalities of the poles according to network typology and supply voltage see the tables of Chapter 7: "Choice of the protective device".

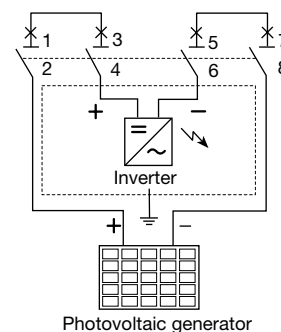


The following table shows the electrical characteristics of the MCBs type S280 UC:

		S280 UC	
Reference Standard		CEI EN 60947-2, UL 1077, CSA 22.2 No. 235	
Rated current I_n	[A]	$0.5 \leq I_n \leq 40$	$50 \leq I_n \leq 63$
Poles		1P, 2P	
Rated voltage U_e according to CEI EN 60947-2	d.c. 1P [V]	220	
	d.c. 2P, 3P, 4P [V]	440	
Rated voltage U_e according to UL 1077/CSA 22.2 No. 235	d.c. 1P [V]	250	
	d.c. 2P, 3P, 4P [V]	500	
Insulation voltage U_i	[V]	500	
Max. operating voltage U_b max according to CEI EN 60947-2	d.c. 1P [V]	242	
	d.c. 2P, 3P, 4P [V]	484	
Max. tensione di esercizio U_b max according to UL 1077/CSA 22.2 No. 235	d.c. 1P [V]	250	
	d.c. 2P, 3P, 4P [V]	500	
Rated breaking capacity IEC 60947-2 1P - 220 Vd.c., 2P - 440 Vd.c.	estremo lcu [kA]	6	4.5
	servizio lcs [kA]	6	4.5
Rated impulse voltage (1.2/50) U_{imp}	[kA]	5	
Dielectric test voltage at industrial frequency for 1 min.	[kA]	2.5	
Characteristics of the thermomagnetic release	B: $3I_n < I_m < 5 I_n$	■	
	C: $5I_n < I_m < 10 I_n$	■	
	K: $8I_n < I_m < 14 I_n$	■	
	Z: $2I_n < I_m < 3 I_n$	■	
Number of electrical operations		1000	
Number of mechanical operations		20000	

For the pole connections please refer to the following electrical scheme:

S 284 UC Z - IT System



Unlike S280 UC, the miniature circuit-breakers series S800S UC can be connected without respect of the polarity (+/-).



For the circuit-breakers series S800S UC the available characteristic curves are B and K and both typologies have rated currents up to 125A and breaking capacity of 50kA.

As regards the connection modalities of the poles according to network typology and supply voltage see the tables of Chapter 7: "Choice of the protective device".

The following table shows the electrical characteristics of the MCBs type S800S UC:

			S800S UC
Reference Standard			IEC 60947-2
Rated current I_n	[A]		10...125
Poles			1, 2, 3, 4
Rated voltage U_e	d.c./poles	[V]	250
Max. operating voltage $U_b \text{ max}$	d.c./poles		250
Insulation voltage U_i	d.c./poles	[V]	250
Rated impulse voltage U_{imp}	d.c./poles	[kV]	8
Rated ultimate short-circuit breaking capacity I_{cu} IEC 60947-2		[kA]	50
Rated service short-circuit breaking capacity I_{cs} IEC 60947-2		[kA]	50
Suitable for isolation in compliance with CEI EN 60947-2		[kA]	3
Characteristics of the thermomagnetic release	B: $4I_n < I_m < 7 I_n$		■
	K: $7I_n < I_m < 14 I_n$		■

The series of products S800 PV includes devices suitable to be used in d.c. circuits with high voltages, typical of photovoltaic plants (in the connection section between panels and inverter).

The S800PV-S providing maximum safety even in the event of reverse polarisation, the S800PV-S series offers high performance in a compact design. The interchangeable terminals (ring lugs or cage terminals) make the system even more convenient. In addition, busbar are available for fast and easy serial pole connection.

The switch disconnecter S800PV-M is used as a main switch for PV systems - the whole DC side can be safely isolated, either locally or remotely. The device offers safety-relevant isolation properties. The disconnecter is guaranteed up to 125A rated current up to 60°C ambient temperature. S800PV-M guarantees safe switching under load and is suitable for international use.



The following table shows the electrical characteristics of the MCBs and switch-disconnectors of the series S800 PV

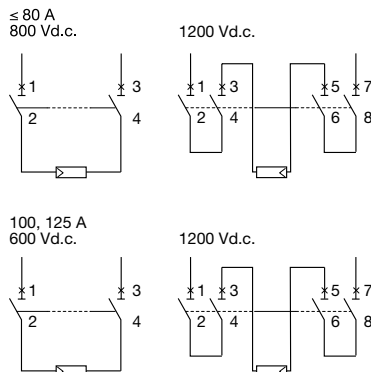
		S800 PV-S	S800 PV-M
Reference standard		CEI EN 60947-2	CEI EN 60947-3
Rated service current, I _n	[A]	10...125	32, 63, 125
Poles		2, 4	2, 4
Rated service voltage, U _e	2 poles (d.c.)*	800 (I _n =10...80A); 600 (I _n =100, 125A)	800 (I _n =32...125A)
	4 poles (d.c.)*	1200	1200
Rated insulation voltage, U _i	[V]	1500	
Rated impulse withstand voltage, U _{imp}	[kV]	8	
Rated ultimate short-circuit current, I _{cu}	800 Vd.c. (2 poles)*	5	-
	1200 Vd.c. (4 poles)*	5	-
Rated service breaking capacity, I _{cs}	800 Vd.c. (2 poles)*	5	-
	1200 Vd.c. (4 poles)*	5	-
Rated short-time withstand current, I _{cw}	800 Vd.c. (2 poles)*	-	1.5
	1200 Vd.c. (4 poles)*	-	1.5
Rated short-circuit making capacity, I _{cm}	800 Vd.c. (2 poles)*	-	0,5
	1200 Vd.c. (4 poles)*	-	0,5
Utilization category		A	DC-21A

* Please refer to the connection diagrams

For the pole connections please refer to the following modalities:

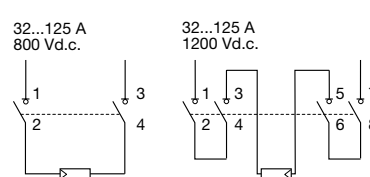
S 800 PV-S

Non-earthed network



S 800 PV-M

Non-earthed network



Molded-case circuit-breakers

Molded-case circuit-breakers series SACE Tmax XT, complying with the Standard IEC 60947-2 and equipped with thermal magnetic trip units, are divided into four basic sizes, with an application field from 1.6A to 250A and current breaking capacities ranging from 16 kA to 100 kA (at 250Vd.c. with two poles in series).

The available molded-case circuit-breakers are:

- SACE Tmax XT CBs type XT1, XT2, XT3 and XT4 equipped with TMD thermomagnetic trip units with adjustable thermal threshold ($I_1 = 0.7...1 \times I_n$) and fixed magnetic threshold ($I_3^* = 10 \times I_n$);
- SACE Tmax XT CBs type XT2 and XT3 equipped with TMG thermomagnetic trip units with low magnetic threshold for the protection of long cables provide adjustable thermal threshold ($I_1 = 0.7...1 \times I_n$) and fixed ($I_3^* = 3 \times I_n$) or adjustable ($I_3^* = 2.5...5 \times I_n$) magnetic threshold;
- SACE Tmax XT CBs type XT2 and XT4 with TMA thermomagnetic trip units with adjustable thermal threshold ($I_1 = 0.7...1 \times I_n$) and adjustable magnetic threshold ($I_3^* = 5...10 \times I_n$).

As regards the connection modality of poles required according to network typology and supply voltage please refer to Chapter 7: "Choice of the protective device".

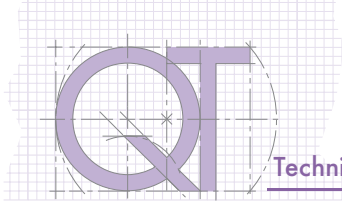


Three-pole circuit-breakers type XT2, XT3 and XT4 can be equipped also with magnetic only trip units MF and MA.

*As reported in Chapter 8 "Use of alternating current equipment in direct current", the trip threshold value varies depending on the connection modality of the poles.

The following table shows the electrical performances of d.c. MCCBs type SACE Tmax XT

Size	[A]	XT1					XT2					XT3		XT4				
		B	C	N	S	H	N	S	H	L	V	N	S	N	S	H	L	V
Poles	[Nr.]	3/4					3/4					3/4		3/4				
Rated service voltage U_e	Vd.c.	500					500					500		500				
Rated impulse withstand voltage U_{imp}	[kV]	8					8					8		8				
Rated insulation voltage U_i	[V]	800					1000					800		1000				
Rated ultimate short circuit breaking capacity I_{cu}		B	C	N	S	H	N	S	H	L	V	N	S	N	S	H	L	V
250Vd.c. - 2 poles in series	[kA]	18	25	36	50	70	36	50	70	85	100	36	50	36	50	70	85	100
500Vd.c. - 2 poles in series	[kA]	-	-	-	-	-	-	-	-	-	-	-	-	36	50	70	85	100
500Vd.c. - 3 poles in series	[kA]	18	25	36	50	70	36	50	70	85	100	36	50	36	50	70	85	100
Utilization category (IEC 60947-2)		A					A					A		A				
Isolation behaviour		■					■					■		■				
Thermomagnetic releases																		
T adjustable, M fixed	TMD	■					■ (up to 32A)					■		■ (up to 32A)				
T adjustable, M adjustable	TMA	-					■					-		■				
Magnetic only releases	MF/MA						■					■		■				
Interchangeability		-					■					-		■				
Versions		F-P					F-P-W					F-P		F-P-W				



Power distribution

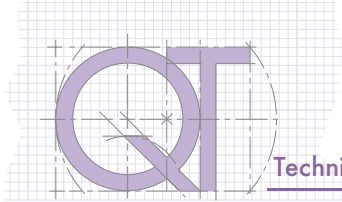
MCCBs	XT1	XT2	XT3	XT4	
In size	160	160	250	250	
1,6	TMD	TMD	TMD	TMD	
2					
2,5					
3,2					
4					
5					
6,3					
8					
10					
12,5					
16	TMD	TMD TMG	TMD	TMD	
20					
25					
32					
40					
50		TMA TMG		TMD TMG	TMA
63					
80					
100					
125					
160	-	TMD/TMG	TMA		
200					
225					
250					

Motor protection

MCCBs	XT2	XT3	XT4
In size	160	250	250
1	MF	TMD	TMD
2			
4			
8,5			
10			
12,5	MF		MA
20	MA		
32			
52			
80			
100			
125	MA		
160			
200			

Caption

TMG= thermomagnetic release with low magnetic threshold
 TMD = thermomagnetic release with adjustable thermal and fixed magnetic threshold
 TMA = thermomagnetic release with adjustable thermal and magnetic threshold
 MF = fixed magnetic only release
 MA = adjustable magnetic only release



The following table shows the rated currents available for the circuit-breakers with the different typologies of trip units

Power distribution

MCCBs In size	T1	T2	T3	T4	T5		T6	
	160	160	250	250	400	630	630	800
1,6								
2								
2,5								
3,2								
4								
5								
6,3								
8								
10								
12,5								
16		TMD						
20		TMD TMG		TMD				
25		TMD TMG						
32		TMD		TMD				
40	TMF TMD	TMD TMG	TMG					
50		TMD		TMD				
63								
80								
100		TMD TMG						
125			TMD TMG	TMA				
160								
200								
250								
320					TMA TMG	TMA TMG		
400								
500								
630							TMA	
800								TMA

Motor protection

MCCBs In size	T2	T3	T4
	160	250	250
1			
1,6			
2			
2,5			
3,2			
4			
5			
6,5			
8,5			
10			MA
11			
12,5			
20	MA		
25			MA
32			
52			
80	MA		
100			MA
125		MA	
160			
200			

Caption

- TMG= thermomagnetic release with low magnetic threshold
- TMF = thermomagnetic release with fixed thermal and magnetic threshold
- TMD = thermomagnetic release with adjustable thermal and fixed magnetic threshold
- TMA = thermomagnetic release with adjustable thermal and magnetic threshold
- MF = fixed magnetic only release
- MA = adjustable magnetic only release

Air circuit-breakers

Air circuit-breakers series Emax, which comply with the Standard IEC 60947-2, equipped with the new d.c. electronic releases type PR122/DC-PR123/DC, are divided into four basic sizes, with an application field from 800A (with E2 CB) to 5000A (with E6 CB) and current breaking capacities ranging from 35 kA to 100 kA (at 500Vd.c.). By using the dedicated voltage module PR120/LV the minimum rated operational voltage becomes equal to 24 Vd.c.

As regards the connection modality of the poles required according to network typology and supply voltage please refer to Chapter 7: "Choice of the protective device".

Thanks to their exclusive technology, the new d.c. electronic releases type PR122DC-PR123/DC designed by ABB SACE allow to cover any possible installation requirement and to perform the protection functions previously available for a.c. applications only.

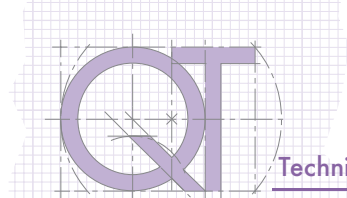
The circuit-breakers series Emax DC keep unchanged

the overall dimensions and the electrical and mechanical accessories common to the Emax range for a.c. applications.



The following table shows the electrical characteristics of ACBs type Emax DC

		E2		E3		E4		E6
Rated operational voltage, Ue	[V]	1000		1000		1000		1000
Rated impulse withstand voltage, Uimp	[kV]	12		12		12		12
Rated insulation voltage, Ui	[V]	1000		1000		1000		1000
Poles	[Nr.]	3/4		3/4		3/4		3/4
Rated uninterrupted current, Iu		B	N	N	H	S	H	H
	[A]	800		800				
	[A]	1000		1000				
	[A]	1250		1250				
	[A]	1600	1600	1600	1600	1600		
	[A]			2000	2000	2000		
	[A]			2500	2500	2500		
	[A]					3200	3200	3200
	[A]							4000
[A]							5000	
Rated ultimate breaking capacity under short-circuit, Icu		see pages 32, 33, 34						
Rated short-time withstand current, Icw (0.5 s)	[kA]							
	500V DC (III)	35	50	60	65	75	100	100
	750V DC (III)	25	25	40	40	65	65	65
	750V DC (IV)	25	40	50	50	65	65	65
	1000V DC (IV)	25	25	35	40	50	65	65
Utilization category (IEC 60947-2)		B	B	B	B	B	B	B
Insulation behaviour		■		■		■		■
Versions		F-W		F-W		F-W		F-W



In addition to the “standard” protection functions (i.e. protection against overload and short-circuit), the new trip units type PR122-PR123DC offer some “advanced” protection functions; all the available functions are summed up in the following table:

Characteristics

Protection functions		PR122	PR123
L	Protection against overload with inverse long time-delay trip	■	■
S	Selective protection against short-circuit inverse or definite short time-delay trip	■	■
S	Second selective protection against short-circuit inverse or definite short time-delay trip		■
I	Protection against instantaneous short-circuit with adjustable trip current threshold	■	■
G	Protection against earth fault		■
U	Protection against phase unbalance		■
OT	Protection against overtemperature (check)	■	■
UV	Protection against undervoltage		■
OV	Protection against overvoltage		■
RP	Protection against reverse active power		■
M	Thermal memory for functions L and S	■	■

For further information please refer to the Annex of Emax technical catalogue

The new electronic trip units, thanks to a new human-machine interface, allow a complete control over the system. More precisely, such releases provide the following measuring and control functions:

Measurements	PR122/DC-PR123/DC
Currents	■
Voltage	■ ⁽¹⁾
Power	■ ⁽¹⁾
Energy	■ ⁽¹⁾
Event marking and maintenance data	
Event marking with the instant it occurred	■
Chronological event storage	■
Counting the number of operations and contact wear	■
Communication with supervision system and centralised control	
Remote parameter setting of the protection functions, unit configuration, communication	opt. ⁽²⁾
Transmission of measurements, states and alarms from circuit-breaker to system	opt. ⁽²⁾
Transmission of the events and maintenance data from circuit-breaker to system	opt. ⁽²⁾
Watchdog	
Alarm and trip for release overtemperature	■
Check of release status	■
Interface with the user	
Presetting parameters by means of keys and LCD viewer	■
Alarm signals for functions L, S, I and G	■
Alarm signal of one of the following protections: undervoltage, overvoltage, residual voltage, active reverse of power, phase unbalance, overtemperature	■
Complete management of pre-alarms and alarms for all the self-control protection functions	■
Enabling password for use with consultation in “READ” mode or consultation and setting in “EDIT” mode	■
Load control	
Load connection and disconnection according to the current passing through the circuit-breaker	■
Zone selectivity	
Can be activated for protection functions S, G ⁽¹⁾	■

(1) for PR 123/DC only

(2) with communication module PR120/D-M

9.2 Switch-disconnectors

To carry out the isolating function and to cut off the power supply from all or from a discrete section of the d.c. installation, the product range offered by ABB SACE is:

- Switch-disconnectors derived from Tmax PV molded-case circuit-breakers

Tmax PV is a new range of T Generation; these are four-pole switch-disconnectors, fixed version, for applications with high DC values, suitable for photovoltaic installations.

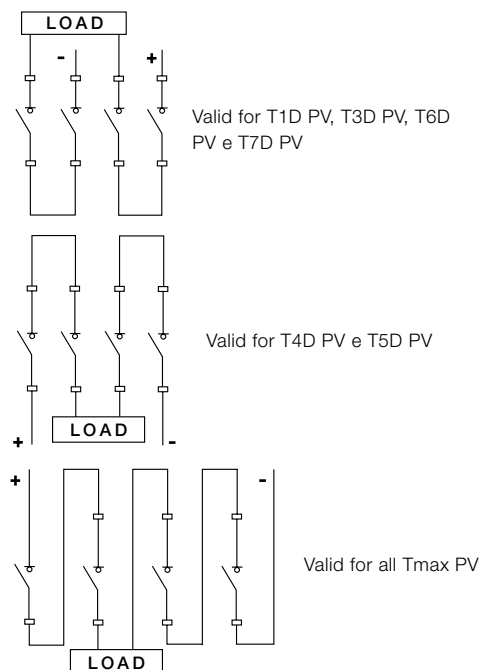
They comply with the Std. IEC 60947-3, have a rated insulation voltage up to 1150V DC, service currents up to 1600A and a rated short-time withstand current I_{cw} for 1 s up to 19.2 kA.

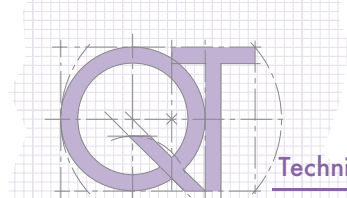
Tmax PV range includes six different sizes: from the compact T1D PV (which can be mounted on a DIN rail) to the T7D PV available in two versions, either with operating lever or motor operated mechanism. The accessories are the same as the standard series. The whole range can be remote-controlled by adding the motor operators.

Available size and main characteristics Tmax PV

	T1D PV	T3D PV	T4D PV	T5D PV	T6D PV	T7D PV
Conventional thermal current I_{th} [A]	160	250	250	630	800	1600
Rated service current in category DC22 B, I_e [A]	160	200	250	500	800	1600
Rated service voltage U_e [V]	1100 V DC	1100 V DC	1100 V DC	1100 V DC	1100 V DC	1100 V DC
Rated impulse withstand voltage U_{imp} [kV]	8	8	8	8	8	8
Rated insulation voltage U_i [V]	1150 V DC	1150 V DC	1150 V DC	1150 V DC	1150 V DC	1150 V DC
Test voltage at industrial frequency for 1 minute [V]	3500	3500	3500	3500	3500	3500
Rated short-time withstand current for 1s, I_{cw} [kA]	1.5	2.4	3	6	9.6	19.2
Versions	F	F	F	F	F	F
Terminals	FC Cu	FC Cu	FC Cu	FC Cu	FC CuAl	FC CuAl
Mechanical life [No. of operations]	25000	25000	20000	20000	20000	10000

The connection diagrams valid for networks insulated from earth are shown hereunder:





- Switch-disconnectors derived from SACE Tmax XT and Tmax T molded-case circuit-breakers

SACE Tmax XT and Tmax T switch-disconnectors derive from the corresponding circuit-breakers of which they keep unchanged the overall dimensions, the versions, the fixing systems and the possibility of mounting the same accessories. This version only differs from the circuit-breakers for the absence of the

protection trip units.

These switch-disconnectors can be used up to 750Vd.c. (with T4D-T5D-T6D-T7D).

As regards the connection modalities of the poles required according to the supply voltage see the tables of Chapter 7: "Choice of the protective device".

The following table shows the electrical characteristics of the switch-disconnectors derived from Tmax molded-case circuit-breakers:

	XT1D	XT3D	XT4D	T1D	T3D	T4D	T5D	T6D	Tmax T7D
Conventional thermal current, I _{th} [A]	160	250	250	160	250	250/320	400/630	630/800/1000	1000/1250/1600
Rated service in category DC22 [A]	160	250	250	160	250	250/320	400/630	630/800/1000	1000/1250/1600
Poles [No.]	3/4	3/4	3/4	3/4	3/4	3/4	3/4	3/4	3/4
Rated service voltage, U _e [V]	500	500	500	500	500	750	750	750	750
Rated impulse withstand voltage, U _{imp} [kV]	8	8	8	8	8	8	8	8	8
Rated insulation voltage, U _i [V]	800	800	800	800	800	800	800	1000	1000
Rated short-time withstand current I _{cw} [kA]	2	3.6	3.6	2	3.6	3.6	6	15	20
Reference Standard	CEI EN 60947-3								
Versions	F - P	F - P	F - P - W	F	F - P	F - P - W	F - P - W	F-W	F-W

- Switch-disconnectors derived from Emax air circuit-breakers

Emax switch-disconnectors derive from the corresponding circuit-breakers of which they maintain the overall dimensions and the possibility of mounting the same accessories. This version differs from the circuit-breakers only for the absence of overcurrent trip units. These switch-disconnectors are available both

in fixed, as well as in withdrawable version, three- or four-pole, and can be used according to utilization category DC 23A (switching of motors or other highly inductive loads, e.g. motors in series). As regards the connection modalities of the poles required according to the supply voltage see Table 13.

The following table shows the electrical characteristics of the Emax switch-disconnector

		X1B/MS	E1B/MS	E1N/MS	E2B/MS	E2N/MS	E2S/MS	E3N/MS	E3S/MS	E3V/MS	E4S/MS	E4H/fMS	E4H/MS	E6H/MS	E6H/fMS
Rated uninterrupted current (at 40 °C) I _u	[A]	1000	800	800	1600	1000	1000	2500	1000	800	4000	3200	3200	4000	4000
	[A]	1250	1000	1000	2000	1250	1250	3200	1250	1250		4000	4000	5000	5000
	[A]	1600	1250	1250		1600	1600		1600	1600				6300	6300
	[A]		1600	1600		2000	2000		2000	2000					
	[A]								2500	2500					
	[A]								3200	3200					
Rated operational voltage U _e	[V ~]	250	250	250	250	250	250	250	250	250	250	250	250	250	250
Rated insulation voltage U _i	[V ~]	1000	1000	1000	1000	1000	1000	1000	1000	1000	1000	1000	1000	1000	1000
Rated impulse withstand voltage U _{imp}	[kV]	12	12	12	12	12	12	12	12	12	12	12	12	12	12
Rated short-time withstand current I _{cw}	1s [kA]	42	42	50	42	55	65	65	75	85	75	85	100	100	100
	3s [kA]		42	42	42	42	42	65	65	65	75	75	75	85	85

Annex A

Direct current distribution systems

The Standard IEC 60364-1 defines the direct current distribution systems analogously to the alternating current ones:

TT system

a polarity of the system and the exposed conductive-parts are connected to two electrically independent earthing arrangements. If necessary, the middle point of the supply can be connected to earth.

Figure 18 TT d.c. system

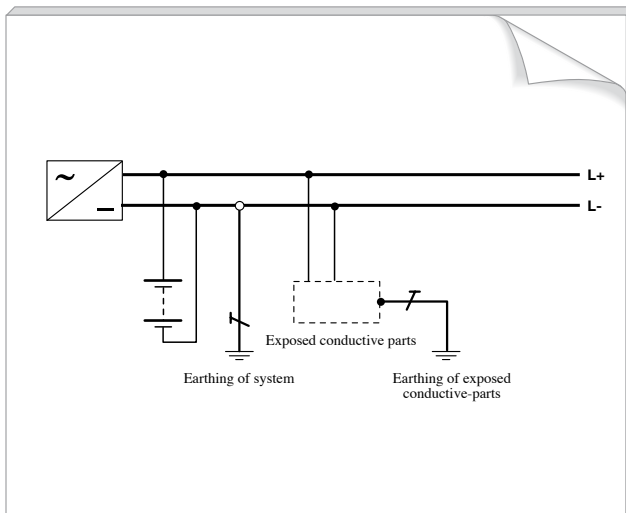
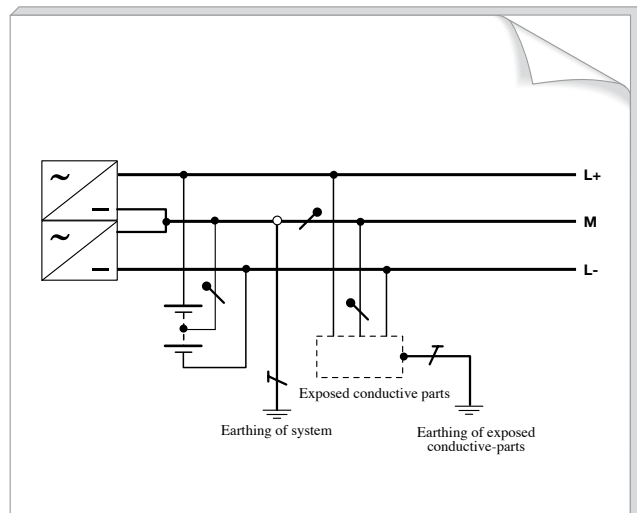


Figure 19 TT d.c. system with the middle point of the supply connected to earth



The choice of earthing either the positive or the negative polarity is made according to considerations not treated in this Annex.

TN system

a polarity, or the middle point of the supply, is directly earthed; the exposed-conductive-parts are connected to the same earthed point. Three types of TN system are defined according to whether the earthed polarity and the protective conductor are separated or not:

1.TN-S system – the conductor of the polarity connected to earth and the protective conductor PE are separated

Figure 20 TN-S d.c. distribution system

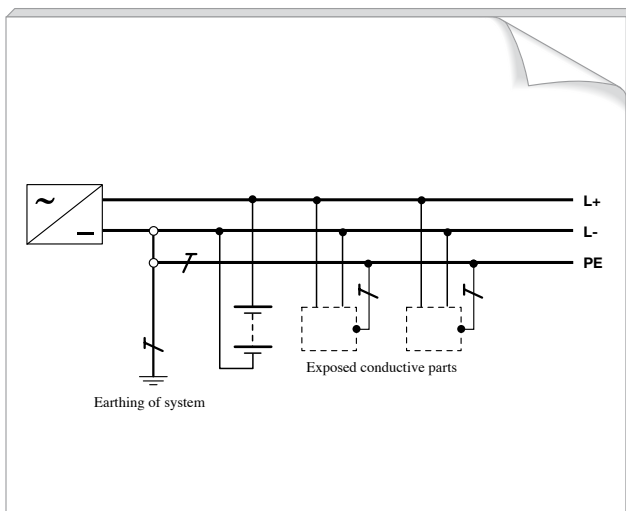
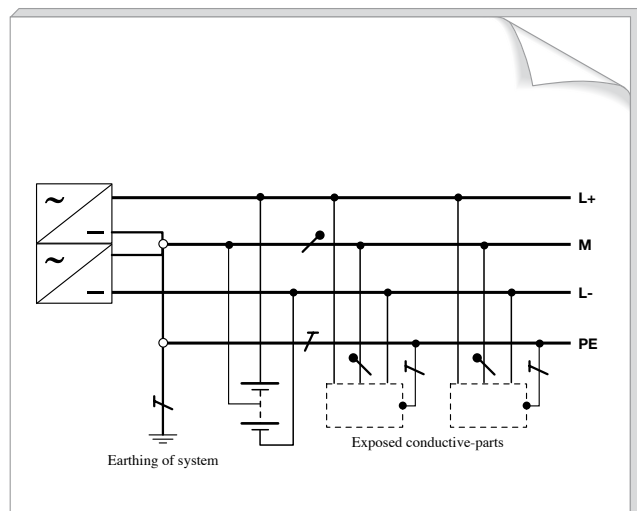


Figure 21 TN-S d.c. system with the middle point of the supply connected to earth



2. TN-C system – the functions earthed polarity and protective conductor are partially combined in a single conductor called PEN

Figure 22 TN-C d.c. distribution system

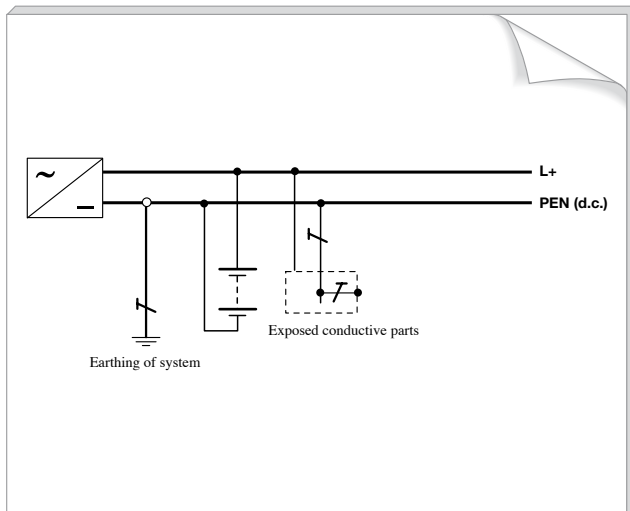
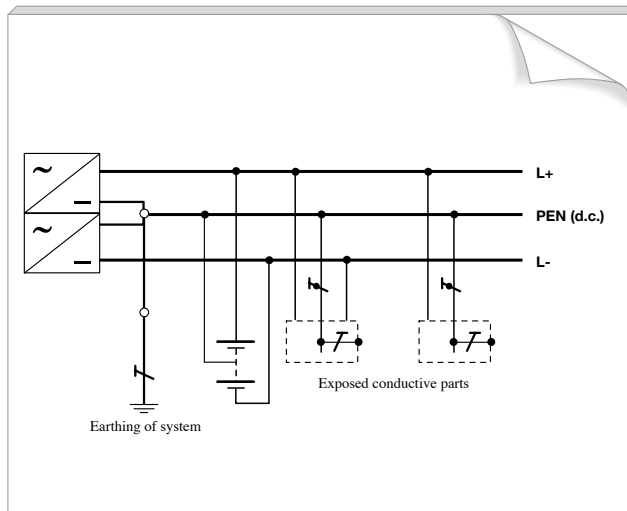


Figure 23 TN-C d.c. distribution system with the middle point of the supply source connected to earth



3. TN-C-S system – the functions of earthed polarity and of protective conductor are partially combined in a single conductor called PEN and partially separated

Figure 24 TN-C-S d.c. distribution system

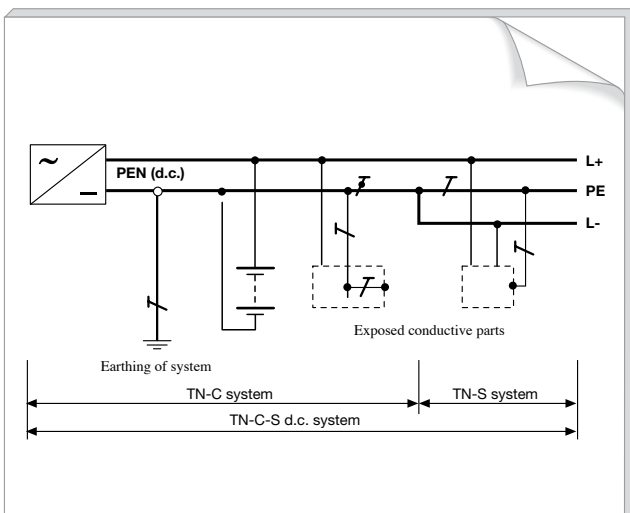
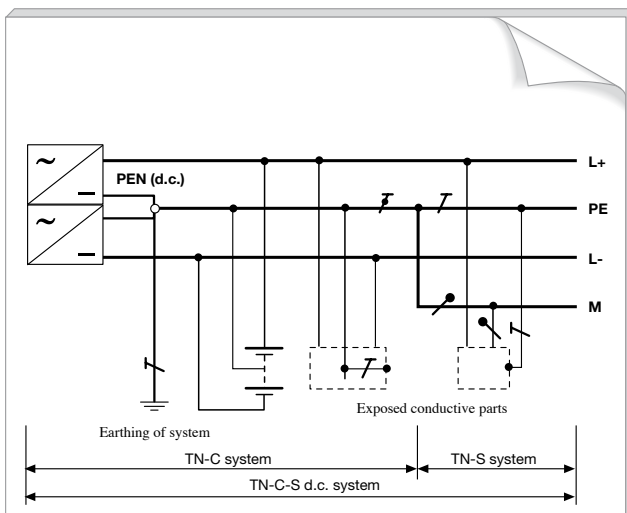


Figure 25 TN-C-S d.c. distribution system with the middle point of the supply source connected to earth



IT system

the supply source is not earthed; the exposed-conductive-parts are connected to the same earthing point.

Figure 26 IT d.c. distribution system

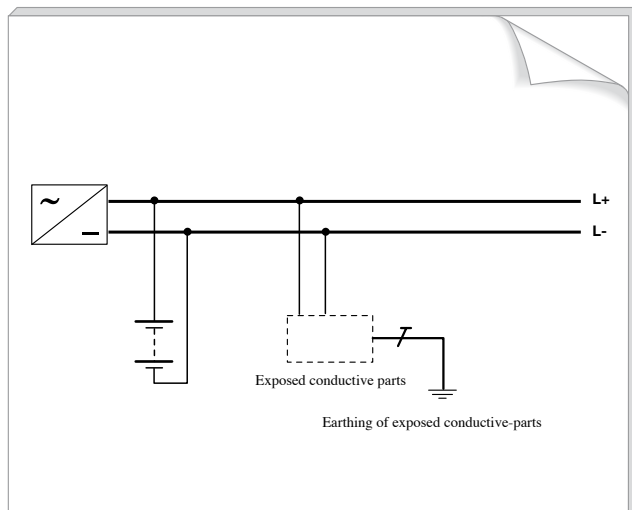
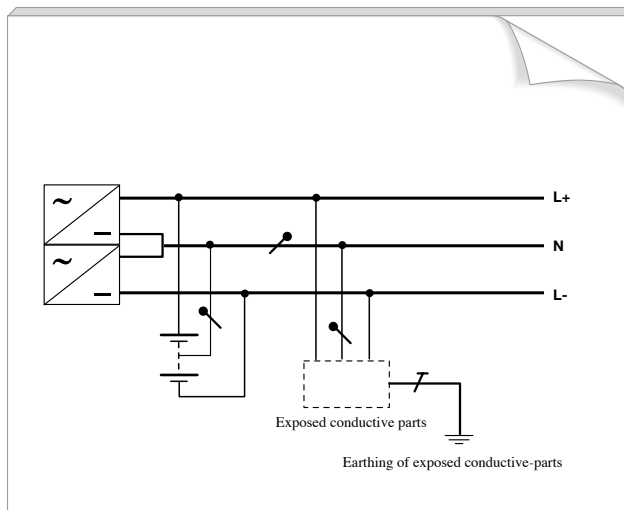


Figure 27 IT d.c. distribution system with the middle point of the supply isolated from earth



Protection against indirect contact

To the purpose of protection against direct and indirect contacts, the Standard IEC 60364-4 prescribes that the protective device shall automatically disconnect the supply so that in the event of a fault between a live part and an exposed-conductive-part or a protective conductor, a voltage exceeding 120 V (d.c.) does not persist for a time sufficient to cause harmful physiological effects for a human body⁽¹⁾.

For particular environments tripping times and voltage values lower than the above mentioned ones may be required. Further requirements for d.c. systems are being studied at present.

⁽¹⁾ For IT systems, the automatic opening of the circuit is not necessarily required in the presence of a first fault

Annex B

Calculation of short-circuit currents

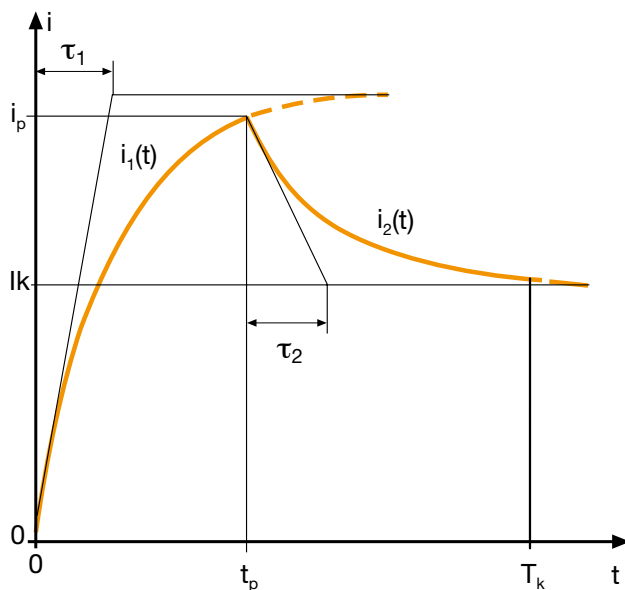
The study of short-circuit currents is fundamental to a correct dimensioning of the components constituting the plant; as a matter of fact, a wrong evaluation could involve a selection of undersized devices for the performances under short-circuit conditions.

Here are some brief considerations on how to assess the short-circuit current in compliance with the prescriptions of the international Standard IEC 61660-1: "Short-circuit currents in d.c. auxiliary installations in power plants and substations".

The above mentioned Standard provides some calculation methods which produce results of sufficient accuracy as regards the variations of the short-circuit currents relevant to electrical components acting as short-circuit current sources.

Although the Standard gives indications by analyzing different supply sources, we would take into consideration only the information about stationary lead-acid batteries and to give the time-current curves of the other sources (rectifiers in three-phase a.c. bridge connection for 50 Hz, smoothing capacitors and d.c. motors with independent excitation).

The terms used in the formulas refer to the following figure, which represents the typical curve of a direct short-circuit current:



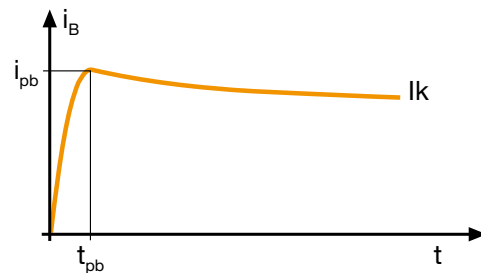
Where:

- I_k is the quasi steady-state short-circuit-current
- i_p is the peak short-circuit current
- T_k is the short-circuit duration
- t_p is the time to peak
- τ₁ is the rise time constant
- τ₂ is the decay-time constant.

Calculation of the short-circuit current provided by a stationary lead-acid battery

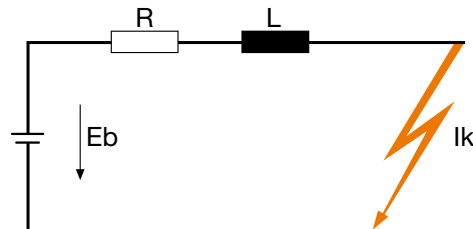
The following figure shows the curve of the short-circuit current delivered by a stationary lead-acid battery; as it can be seen in the figure, after the time t_{pb}, that is the time necessary to reach the peak (i_{pb}), the short-circuit value decreases to the quasi steady-state short-circuit current.

Figure 28 Curve of the short-circuit current in a stationary lead-acid battery



The calculations on the following pages refer to this schema:

Figure 29 Schema referred to the d.c. circuit



Where:

$$R = 0.9 \cdot R_b + R_{bl} + R_y$$

- R_b = resistance of the battery in case of short-circuit (value specified by the manufacturer)
- R_{bl} = resistance of the conductor in the battery branch
- R_y = resistance of the common branch with other supply sources, if it exists

$$L = L_b + L_{bl} + L_y$$

- L_b = inductance of the battery in case of short-circuit (value specified by the manufacturer)
- L_{bl} = inductance of the conductor in the battery branch
- L_y = inductance of the common branch, if it exists
- E_b = open-circuit voltage of the battery

Peak short-circuit current:

$$i_{pb} = \frac{E_b}{R}$$

Quasi steady-state short-circuit current:

$$I_{kb} = \frac{0.95 E_b}{R + 0.1 R_b}$$

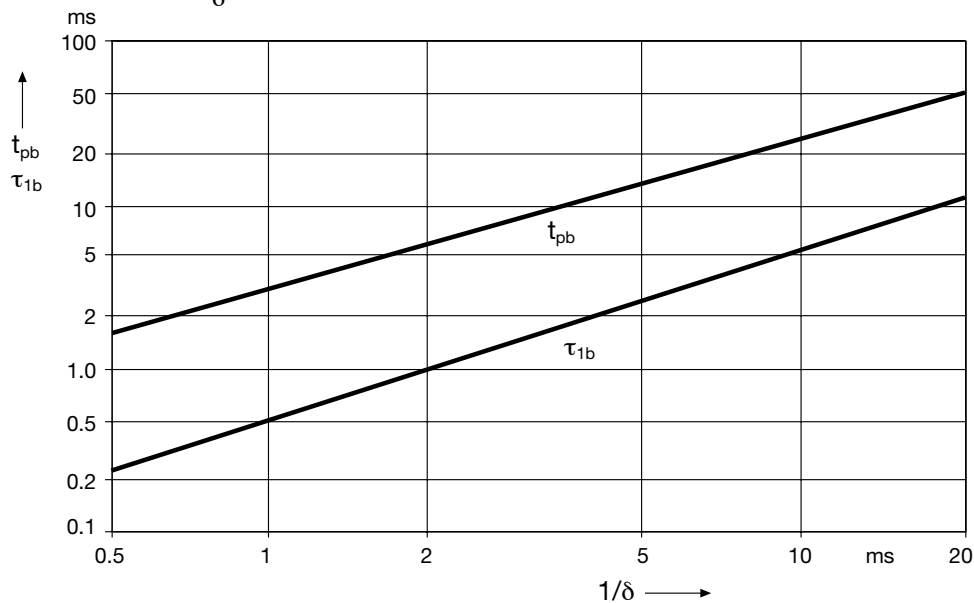
Time to peak t_p and rise time constant τ_1

To determine these parameters it is necessary to calculate the relationship:

$$\frac{1}{\delta} = \frac{1}{\frac{R}{L} + \frac{1}{T_B}}$$

with the time constant $T_B = 30\text{ms}$

Once the ratio $\frac{1}{\delta}$ has been calculated, it is possible to determine t_p and τ_1 from the following graph:

**Decay-time constant τ_2**

The decay-time constant is equal to $\tau_2 = 100\text{ms}$

Calculation example of the short-circuit current of an accumulator batteries

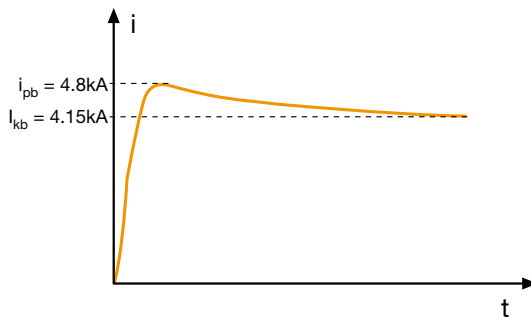
Calculate the short-circuit current of a battery having the following characteristics:

- maximum discharge voltage = 240Vd.c.
- capacity of the battery = 50 Ah
- number of monoblocks in series = 110 (2.2 V for each monoblock)
- internal resistance of the single monoblock = 0.5 mΩ

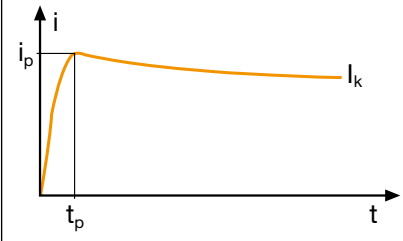
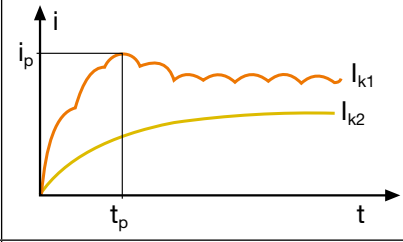
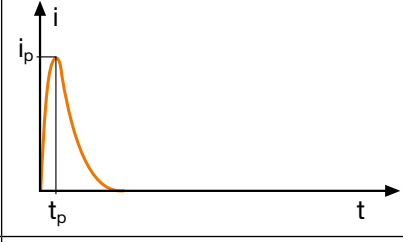
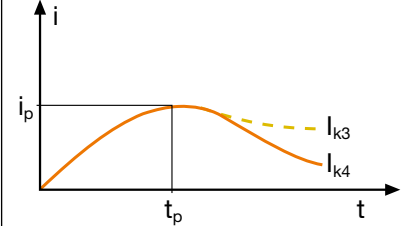
$$R_{tot} = N^{\circ}_{\text{no. of monoblocks}} \times R_i = 110 \times 0.5 \times 10^{-3} = 0.055 \Omega$$

$$I_{kb} = \frac{0.95 \times E_b}{R_{tot}} = \frac{0.95 \times 240}{0.055} = 4.15 \text{ kA}$$

$$i_{pb} = \frac{E_b}{0.9 \times R_{tot}} = \frac{240}{0.9 \times 0.055} = 4.8 \text{ kA}$$



The following table summarizes all the variations of the short-circuit currents indicated and described in the Standard IEC 61660-1 and relevant to the different equipment acting as short-circuit sources:

Equipment acting as short-circuit sources	Short-circuit current variations	Description
Stationary lead-acid battery		i_p = peak short-circuit current t_p = time to peak I_k = quasi steady-state short-circuit current
Rectifiers in three-phase a.c. bridge connections for 50Hz without (I_{k2}) and with smoothing reactor (I_{k1})		
Smoothing capacitors		
D.c. motors with independent excitation without additional inertia mass (I_{k4}) or with additional inertia mass (I_{k3})		

Annex C

Circuit-breakers and switch-disconnectors for applications up to 1000Vd.c.

The main installations at 1000Vd.c. are used for traction, mines, road tunnels, railway applications and industrial applications in general.

The use of this high voltage value finds an application in those plants where it is necessary to have distribution lines longer than normal LV lines or in those applications requiring big power. In those circumstances, to keep the rated and the short-circuit currents reduced, it is necessary to increase the rated voltage of the plant.

Thus, it is possible to use conductors with smaller cross sectional areas both in the switchboards as well as in the distribution lines with a consequent reduction in the initial investment costs and in the running costs due to the decrease in the power losses caused by the joule effect.

Another advantage is represented by the saving of the space taken up by the cable runs thanks to the reduction in their cross sectional area. For further applications, such as for example installations in mines, the narrowness of the available spaces amplifies enormously the problem of the arrangement of the run and of the positioning of the conductors in relation to air/suction ducts and air conditioning.

Besides, with a voltage of 1000V, it is possible to reduce the percentage voltage drop, thus obtaining longer distribution lines; that is the reason why such voltage is used in installations with particular requirements of length.

The increase in voltage brings with it also better service

conditions thanks to the reduction in the short-circuit levels, thus limiting the consequences of possible faults and improving safety.

However, the use at 1000V affects the choice, the availability and the cost of the switching and protection devices which can be used and which, in comparison with the available range of products available for the voltages usually employed in the normal LV distribution systems (up to 690Va.c. or up to 750Vd.c.) constitute a dedicated special version.

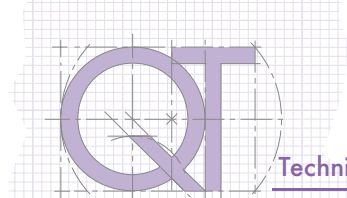
These special versions have constructional characteristics necessary to meet the most severe requirements (increase in the test voltage).

ABB SACE offer for use up to 1000Vd.c.

The range of products offered by ABB SACE for applications up to 1000Vd.c. includes products which guarantee the protection function or the isolation function only.

When choosing a circuit-breaker, it is necessary to take into consideration the earthing modality of the plant in order to define the number of poles to be connected in series with the purpose of realizing working conditions under which, if a short-circuit occurs, the current breaking is carried out by the series of the 4 CB contacts, thus guaranteeing the assigned breaking capacity for the device (in case of a protective circuit-breaker).

In the following pages both the electrical characteristics of the products as well as the connection modalities of poles are reported.



Circuit-breakers for use up to 1000Vd.c.

Tmax circuit-breakers equipped with thermomagnetic trip unit

Tmax circuit-breakers for use in direct current up to 1000V have the same dimensions as the standard ones and are available in the fixed, plug-in and withdrawable version; they can be fed from the top only and can be equipped only with adjustable thermomagnetic trip units; besides, they are compatible with all the accessories provided for the standard version except for the residual current release.

The following table shows the electrical characteristics of Tmax circuit-breakers for 1000Vd.c. applications

		Tmax T4	Tmax T5	Tmax T6
Rated uninterrupted current, Iu	[A]	250	400/630	630/800
Poles	[Nr.]	4	4	4
Rated service voltage, Ue	[V]	1000	1000	1000
Rated impulse withstand voltage, Uimp	[kV]	8	8	8
Rated insulation voltage, Ui	[V]	1150	1150	1000
Test voltage at power frequency for 1 min.	[V]	3500	3500	3500
Rated ultimate short-circuit breaking capacity, Icu		V	V	L
(DC) 4 poles in series	[kA]	40	40	50
Rated service short-circuit breaking capacity, Ics				
(DC) 4 poles in series	[kA]	20	20	
Utilization category (IEC 60947-2)		A	B (400 A)(1) - A (630 A)	B(2)
Insulation behaviour		■	■	■
Reference Standard		IEC 60947-2	IEC 60947-2	IEC 60947-2
Thermomagnetic trip units	TMD	■	-	-
	TMA	■	■	■

(1) Icw = 5kA

(2) Icw = 7.6kA (630A) - 10kA (800A)

Emax circuit-breakers equipped with electronic trip units

Emax circuit-breakers for use in direct current up to 1000Vd.c. can cover installation requirements up to 5000A. These circuit-breakers have the same dimensions as the standard ones, are available in the fixed and withdrawable version and can be equipped with electronic trip units type PR122-PR123DC; they are compatible with all the accessories provided for the standard version.

The following table shows the electrical characteristics of Emax circuit-breakers equipable with the new PR122-PR123/DC trip unit referred to 1000Vd.c.

		E2		E3		E4		E6
Rated uninterrupted current, Iu	(A)	B	N	N	H	S	H	H
	(A)	800	1600	800	1600	1600	3200	3200
	(A)	1000		1000	2000	2000		4000
	(A)	1250		1250	2500	2500		5000
	(A)	1600		1600		3200		
	(A)			2000				
	(A)			2500				
Poles	(Nr)	3/4		3/4		3/4		3/4
Rated voltage service, Ue	V	< 1000		< 1000		< 1000		< 1000
Rated impulse withstand voltage, Uimp	kV	12		12		12		12
Rated insulation voltage, Ui	V	1000		1000		1000		1000
Rated ultimate breaking capacity under short-circuit, Icu	1000 Vd.c. (kA)	see chapter 7						
Rated service breaking capacity under short-circuit, Ics	1000 Vd.c. (kA)	100%	100%	100%	100%	100%	100%	100%
Rated short-time withstand current Icw (0.5s)	1000 Vd.c. (kA)	25	25	35	40	50	65	65
Utilization category (IEC 60947-2)		B		B		B		B
Insulation behaviour		■		■		■		■
Electronic releases	PR122/DC	■		■		■		■
	PR123/DC	■		■		■		■

The table below shows the pole connection modalities with circuit-breakers up to 1000Vd.c. according to the network connection typologies. This table is valid for both Tmax MCCBs equipped with thermomagnetic trip units (the prescribed connections shall be carried out by the customers) as well as for Emax ACBs equipped with the new d.c. electronic trip units PR122-P123/DC (connections carried out in the factory by ABB SACE).

Table 20 Connection modalities of poles with circuit-breakers for applications up to 1000Vd.c

Rated voltage (Un)	1000 Vd.c.		
Type of network	INSULATED NETWORK	NETWORK WITH ONE POLARITY CONNECTED TO EARTH*	NETWORK WITH THE MIDDLE POINT OF THE SUPPLY SOURCE CONNECTED TO EARTH
Description	<p>With this network typology, a fault is considered to be significant when it occurs between the positive and the negative polarity, which makes the series of the 4 CB poles open the circuit.</p> <p>The possibility of a double fault to earth (the first fault on the supply side of the poles of one polarity and the second one on the load side of the poles of the other polarity) is not considered, therefore it is suggested the use of a device to monitor the insulation to earth, capable of signaling the decrease of the insulation to earth as a consequence of a first fault to earth.</p>	<p>With this network typology, the poles connected on the polarity insulated from earth are called to break a fault current at 1000V; therefore it is necessary to provide on this polarity the series of 4 poles. As a consequence, the earthed polarity cannot be interrupted and often this is not even necessary since it is bound to the earth potential.</p>	<p>With this network typology, the 2 poles connected on one polarity are called to break a fault current at 500V, whereas in case of a fault between the two polarities, the voltage supporting it returns to be 1000V and the proposed diagram allows breaking with 4 poles in series.</p>
Tmax			
Emax			

(*) For Emax circuit-breaker please ask ABB.

Switch-disconnectors for applications up to 1000Vd.c.

ABB SACE has developed a range of switch-disconnectors (Emax/E MS family) for applications in direct current up to 1000V in compliance with the international Standard IEC 60947-3.

These non-automatic circuit-breakers are particularly suitable for use as bus ties or main isolators.

These switch-disconnectors are available both in fixed and withdrawable, three-pole and four-pole versions.

The switch-disconnectors of Emax/E MS family maintain the same overall dimensions and can be equipped with the accessories common to the Emax circuit-breakers.

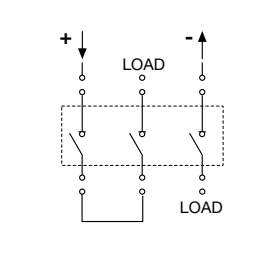
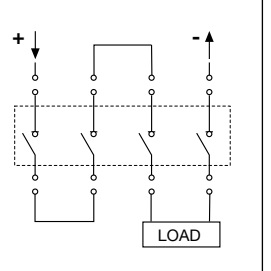
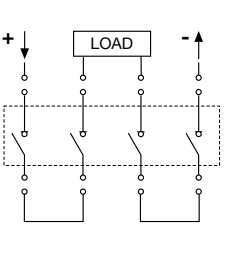
The following table shows the electrical characteristics of the Emax switch-disconnector

		E1B/E MS		E2N/E MS		E3H/E MS		E4H/E MS		E6H/E MS	
Rated current (at 40°C), I _u	[A]	800		1250		1250		3200		5000	
	[A]	1250		1600		1600		4000		6300	
	[A]			2000		2000					
	[A]					2500					
	[A]					3200					
Poles	[Nr.]	3	4	3	4	3	4	3	4	3	4
Rated service voltage, U _e	(d.c.) [V]	750	1000	750	1000	750	1000	750	1000	750	1000
Rated insulation voltage, U _i	(d.c.) [V]	1000	1000	1000	1000	1000	1000	1000	1000	1000	1000
Rated impulse withstand voltage, U _{imp}	[kV]	12	12	12	12	12	12	12	12	12	12
Rated short-time withstand current, I _{cw} (1s)	[kA]	20	20 ⁽¹⁾	25	25 ⁽¹⁾	40	40 ⁽¹⁾	65	65	65	65

⁽¹⁾ The performances at 750 V are:
 for E1B/E MS I_{cw}=25 kA
 for E2N/E MS I_{cw}=40 kA
 for E3H/E MS I_{cw}=50 kA

Hereunder are the wiring diagrams suggested by ABB SACE; the connection of the switch-disconnector poles shall be realized in compliance with them. Also in this case the division of the different connection modalities is carried out according to the installation voltage. As it can be seen from the table below, by connecting three breaking poles in series, it is possible to reach a rated voltage of 750Vd.c, whereas with four poles in series the rated voltage is 1000Vd.c.

Table 21 Connection modalities of poles with Emax/E MS switch-disconnectors for applications up to 1000Vd.c

Rated voltage	750 Vd.c.	1000 Vd.c.	
Poles connection			
E1...E6/E MS	■	■	■

Glossary

I_{max}	maximum current
I_p	short-circuit making current
I_{cn}	prospective short-circuit current
U_a	maximum arc voltage
U_n	line voltage
T	time constant
I_n	rated current of the trip unit
I_{r.m.s}	r.m.s. value of an alternating current
I₃	setting of the instantaneous protection against short-circuit
I₂	setting of the protection against short-circuit with time delay
I₁	setting of the protection against overload
I_{cu}	ultimate short-circuit breaking capacity
I_{cs}	service short-circuit breaking capacity
I_{cw}	rated short time withstand current
U_e	rated operational voltage
TMG	thermomagnetic trip unit with low magnetic threshold
TMF	thermomagnetic trip unit with fixed thermal and magnetic threshold
TMD	thermomagnetic trip unit with adjustable thermal and fixed magnetic threshold
TMA	thermomagnetic trip unit with adjustable thermal and magnetic threshold
MF	magnetic only trip unit, fixed
MA	magnetic only trip unit, adjustable
L	overload protection
S	protection against short-circuit with time-delay trip
I	instantaneous short-circuit protection
I_k	quasi steady-state short-circuit current
i_p	peak short-circuit current
T_k	short-circuit duration
t_p	time to peak
τ₁	rise time constant
τ₂	decay-time constant
i_{pb}	peak short-circuit current supplied by a stationary lead-acid battery
t_{pb}	time to peak in a stationary lead-acid battery
I_{kb}	quasi steady-state short-circuit current of a stationary lead-acid battery

Technical Application Papers

QT1

Low voltage selectivity with ABB circuit-breakers

QT7

**Three-phase asynchronous motors
Generalities and ABB proposals for the coordination of protective devices**

QT2

MV/LV transformer substations: theory and examples of short-circuit calculation

QT8

Power factor correction and harmonic filtering in electrical plants

QT3

Distribution systems and protection against indirect contact and earth fault

QT9

Bus communication with ABB circuit-breakers

QT4

ABB circuit-breakers inside LV switchboards

QT10

Photovoltaic plants

QT5

ABB circuit-breakers for direct current applications

QT11

Guidelines to the construction of a low-voltage assembly complying with the Standards IEC 61439 Part 1 and Part 2

QT6

Arc-proof low voltage switchgear and controlgear assemblies

QT12

Generalities on naval systems and installations on board

QT13

Wind power plants

Contact us

ABB SACE

A division of ABB S.p.A.

L.V. Breakers

Via Baioni, 35

24123 Bergamo - Italy

Phone: +39 035 395 111

Fax: +39 035 395 306-433

www.abb.com

The data and illustrations are not binding.
We reserve the right to make changes in the
course of technical development of the product.

Copyright 2011 ABB. All rights reserved.