



Contents	
1. ESD Warning	2
2. Tools	2
3. Step by step	3

1. ESD Warning

Please note!

The life span of electronics can be affected by damage caused by electrostatic discharge. This can happen if a charged tool or person touches a component. Therefore, it is very important that all tools and personnel are discharged by touching an earthed point before the printed circuit board or any of the components are touched. It is equally important to discharge the package with the new component before opening it.

A person walking on carpet can be charged with up to fifteen thousand volts (15,000V). Compare this with the fact that some sensitive components can be destroyed when discharged on a much lower level (about 100V). We kindly ask you to pay close attention to this, as this is a vital point in order to ensure the life span of the product.

2. Tools

Torx T20 for the cover, gable and contactor to PSTB370...470.

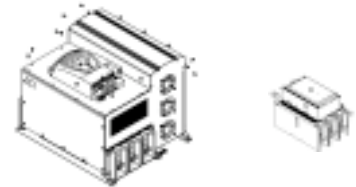

Pozi drive is required to remove the contactor PSTB570

Phillips screwdriver required to remove the contactor PSTB720...1050



Two hexagon key 16 mm for connection between flexi bar and copper bar PSTB370...570.

Two hexagon key 18 mm for connection between flexi bar and copper bar PSTB720...1050.



Hex socket head cap key 8 mm for connection between contactor and bar PSTB370...570.

Hex socket head cap key 10 mm for connection between contactor and bar PSTB720...1050.



3. Step by step

1. Before disconnecting the cables mark them.
2. Disconnect the cables from terminals 1L1, 3L2 and 5L3 (main voltage) and 2T1, 4T2 and 6T3 if necessary (motor connection).
3. Disconnect all cables from terminals 1 to 20, external keypad, PTC sensor and the Fieldbus plug.
4. Remove the top cover (twenty screws).
5. Move the top cover to the right and fix it.

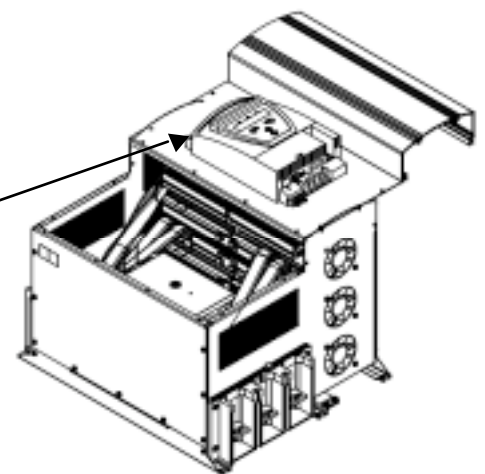
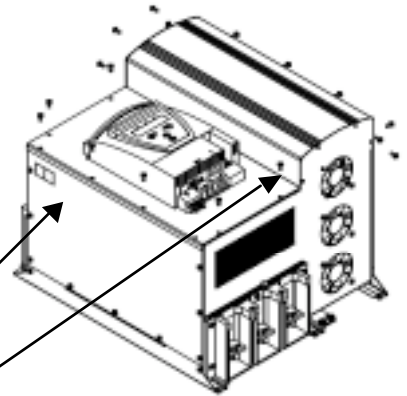

To the contactor

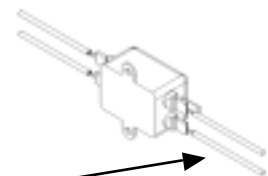

To the PCB

6. For PSTB370...470 remove the connection between the filter and PCB.

7. Remove the nine screws on the left gable.

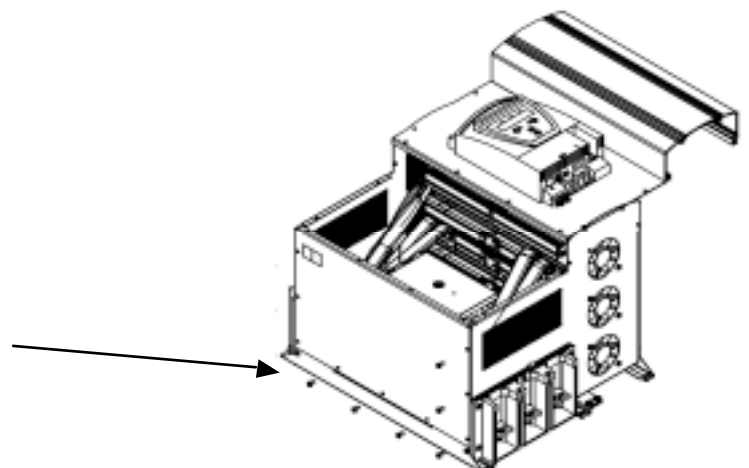

8. To exchange the Main Contacts, Arc Chutes or Coils see Operating instruction for Contactors.
For PSTB370...470 1SFC 380003-89.
For PSTB570...1050 1SFC 380023-en.
Go to step 17

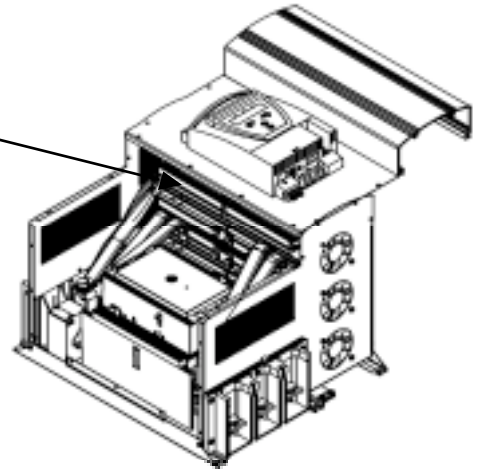

9. Disconnect the flexi bar from the contactor.

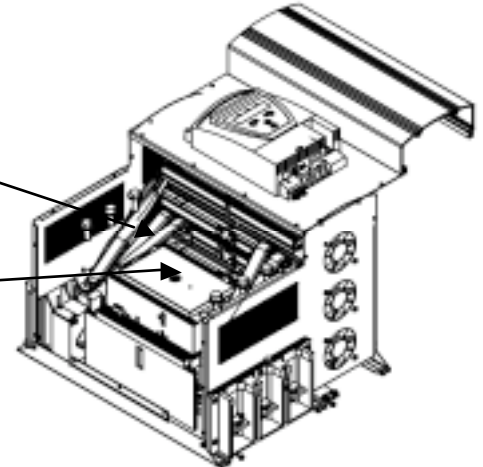

10. Remove the cables from contactor coil.

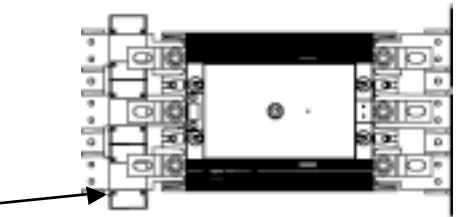

11. Unfasten the six hex socket head cap screws.

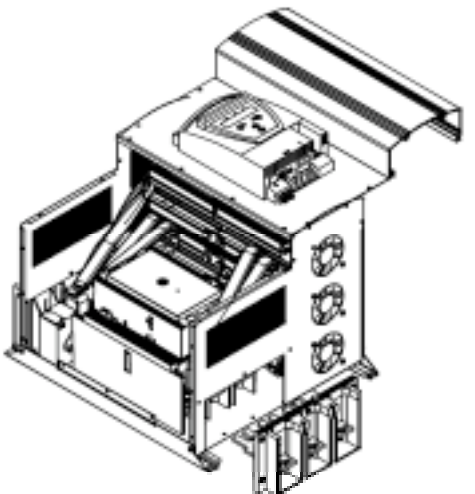

12. Remove the five screws on the bar holder.

13. If there is only three screws in the front of the bar holder, the other two screws are at the bottom.

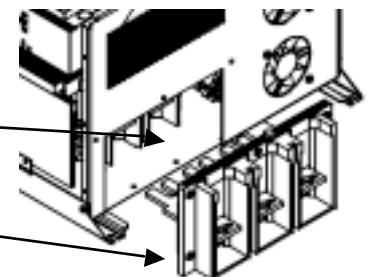

14. Move the Contactor as far as possible in direction of the arrow.

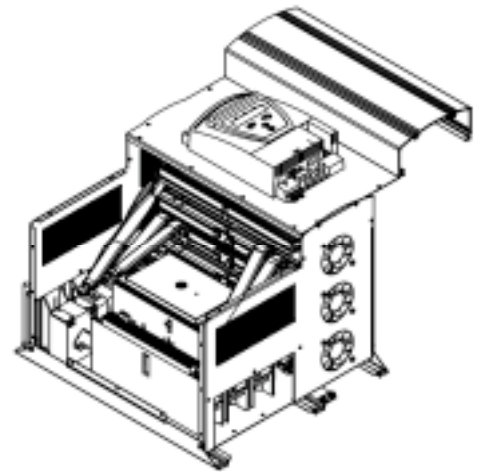

15. Remove the Contactor.

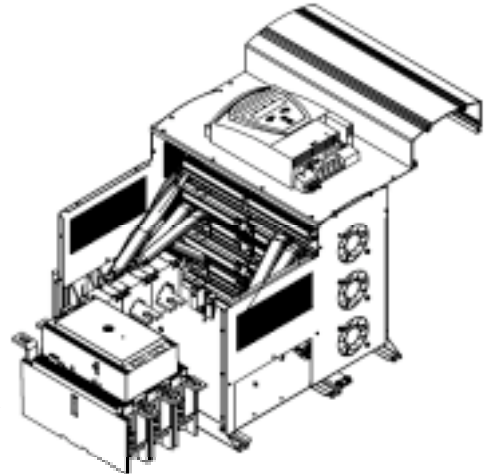

16. Change the Contactor and reassemble the six copper bars with the hex socket head cap screws.

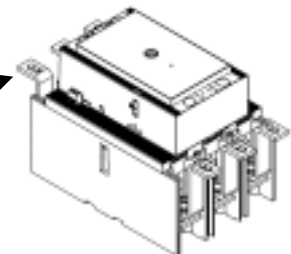

17. Reassemble the softstarter

18. Connect the cables to terminals 1L1, 3L2 and 5L3 (main voltage) and 2T1, 4T2 and 6T3 if necessary (motor connection).

19. Connect all cables to the terminals 1 to 20, external keypad, PTC sensor and the Fieldbus plug.

Ready for start!!



ABB Low Voltage Products & Systems

ABB Inc.

1206 Hatton Road

Wichita Falls, TX 76302

Tel. 888-385-1221

940-397-7000

Fax 940-397-7085

Web www.abb-control.com

1SXU132165M0201 [AC 1006.1]

April, 2004
