

**EIB Delta-Meter Plus  
Electricity Meters**

Intelligent Installation Systems



This manual describes the function and configuration of the EIB Delta-Meter Plus.

Subject to changes and errors excepted.

**Exclusion of liability:**

Despite checking that the contents of this document match the hardware and software, deviations cannot be completely excluded. We therefore cannot accept any liability for this. Any necessary corrections will be inserted in new versions of the manual.

Please inform us of any suggested improvements.

Version: October 2004

---

<b>Contents</b>		<b>Page</b>
<b>1</b>	<b>General description</b> .....	<b>2</b>
<b>2</b>	<b>Device technology</b> .....	<b>3</b>
2.1	Technical data .....	3
2.2	Dimension drawings.....	5
2.3	Important notes.....	6
2.4	Labelling of the EIB Delta-Meter Plus .....	6
<b>3</b>	<b>Assembly and installation</b> .....	<b>7</b>
3.1	Circuit diagrams .....	8
3.2	Adjustable values .....	9
3.3	Pulse outputs (S0) .....	10
<b>4</b>	<b>Function and operation</b> .....	<b>12</b>
4.1	LCD display .....	12
4.2	Light sensor .....	13
4.3	Programming button .....	13
4.4	Indicators in the display .....	14
4.5	Installation self-test .....	14
4.6	Reading out the error codes .....	15
4.7	Network monitoring function.....	15
<b>5</b>	<b>Parameterisation in ETS</b> .....	<b>16</b>
5.1	General.....	16
5.2	Communication objects .....	17
5.3	Parameter options.....	20
5.4	Parameter window: General.....	21
5.5	Parameter window: Meter readings .....	22
5.6	Parameter window: Instantaneous power.....	23
5.7	Parameter window: Status .....	24
5.8	Status byte key table.....	25
<b>6</b>	<b>Appendix</b> .....	<b>26</b>
6.1	Measurement of energy .....	26
6.2	Error codes.....	30
6.3	Standard EIB Delta-Meter Plus with network monitoring function.....	32
6.4	PTB-approved EIB Delta-Meter Plus with official authentication and network monitoring function .....	33

## EIB Delta-Meter Plus Electricity Meters

### 1 General information



DZ+4105 W E

2CDC 101 155 F0004

EIB Delta-Meters Plus are PTB-approved, electronic energy meters with an integrated ABB i-bus® EIB / KNX communication interface.

EIB Delta-Meters Plus are compact, reliable, immune to interference impulses and suitable for use in single-phase and polyphase voltage networks. As the meters have no mechanical moving parts, they can easily be snapped in any position onto DIN rails. The EIB communication interface enables remote reading of the meter data via the ABB i-bus® EIB for billing, energy optimisation, visualisation or installation monitoring purposes.

They can be universally employed for submetering applications in industrial installations, commercial buildings, offices, leisure complexes and private households.

#### Special features:

- Precise measurement of energy consumption (kWh, kvarh with combination meter)
- For 2-, 3- and 4-wire voltage networks with any load
- Integrated EIB / KNX interface for remote reading of meter data
- Network monitoring function: recording and display of up to 24 electrical measured variables
- Automatic wiring check with an installation self-test
- Easy to read LCD display, LED indicator for energy consumption
- Direct connection up to 80 A
- Transformer connection (/1A or /5 A) with transformer rated meter
- Accuracy classes 1 or 2
- Tariff meter with 4 tariffs
- Fulfils standards IEC 61036/61268
- Resistant to shocks and vibration, can be mounted in any position
- System pro M design: can be snapped onto 35 mm DIN rail, sealable

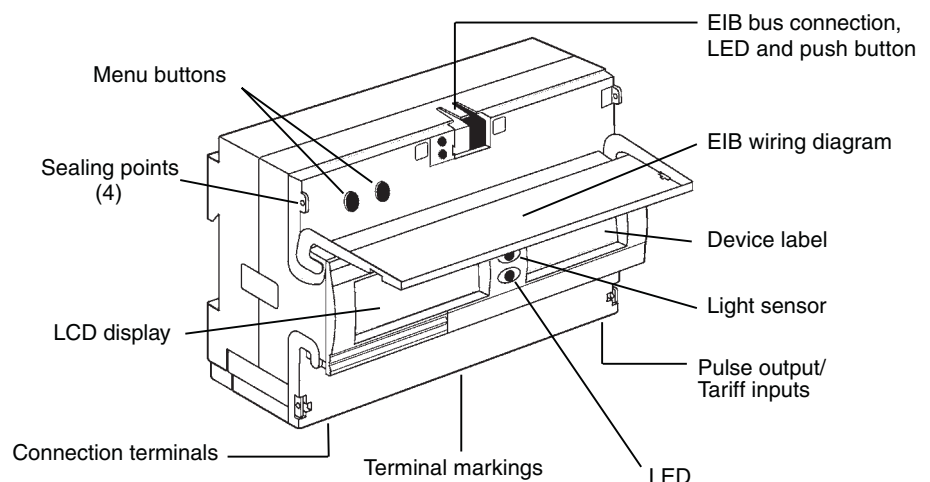

## 2 Device technology

### 2.1 Technical data

<b>Accuracy class:</b>	Transformer rated meter:	Class 1 acc. to IEC 61036
	Direct connected meter:	Class 1 or 2 acc. to IEC 61036
<b>Operating voltage:</b>	Nominal voltage:	See ordering information
	Permitted deviation:	- 20 % ... + 15 % of nominal value
<b>Nominal current <math>I_b</math> (limit current <math>I_{max}</math>):</b>	Transformer rated meter:	1 (6) A
	Direct connected meter:	5 (80) A
<b>Starting current:</b>	Transformer rated meter: (/1 A or /5A transformer)	< 2 mA
	Direct connected meter:	< 20 mA
<b>Power consumption:</b>	Voltage circuit:	< 3 VA, 2 W per phase
	Current circuit:	
	- Transformer rated meter - Direct connected meter	< 0.08 VA per phase < 6 VA per phase
<b>Frequency:</b>	Nominal frequency:	50 Hz/60 Hz ± 5 %
<b>Electromagnetic compatibility (EMC):</b>	Surge voltage:	6 kV, 1.2/50 µs (IEC 600-60)
	Burst:	4 kV (IEC 61000-4-4)
	Electromagnetic fields:	
	- Interference immunity, field: Interference immunity, mains-borne	10 V/m, 80 MHz - 1 GHz (IEC 61000-4-3) 150 kHz – 80 MHz (IEC 61000-4-6)
	- Emitted radiation	according to CISPR 22 class B
	Electrostatic discharge:	15 kV (IEC 61000-4-2)
<b>Overload capability:</b>	All meters:	unlimited $1.2 \times I_{max}$
	Direct connected meter:	1 hour $1.5 \times I_{max}$ 2 sec $15 \times I_{max}$ 10 kA peak
	- Short circuit	
	Transformer rated meter:	0.5 sec $20 \times I_{max}$
<b>Circuit protection:</b>	Transformer rated meter:	max. 10 A B characteristic or gL/gG
	Direct connected meter:	max. 80 A NH00 gL/gG
<b>Environmental conditions:</b>	Ambient temperature (operation):	- 40 °C ... + 55 °C
	Storage temperature:	- 40 °C ... + 70 °C
	Relative humidity:	< 75 % annual average, 95 % max. 30 days/year

## EIB Delta-Meter Plus Electricity Meters

### Mechanical data:

Housing material:	
– Front window and housing	Polycarbonate
– Terminal area	Glass-fibre-reinforced polycarbonate
Dimensions (H x W x D):	97 x 122.5 x 64.8 mm
Protection class:	II
Resistance to heat and fire:	Equivalent to IEC 60695-2-1
Protection against penetration of dust and water:	Equivalent to IEC 60529
Type of protection:	IP 20
Wire range:	
– Transformer rated meter	0.5 to 10 mm <sup>2</sup>
– Direct connected meter	1.0 to 25 mm <sup>2</sup>
Tightening torque:	
– Transformer rated meter	Max. 1 Nm
– Direct connected meter	Max. 2 Nm
Weight:	0.4 kg

### Display:

LCD display:	7-digit, height of figures 7 mm
LED display; pulse length	40 ms
– Direct connected meter	Red LED, 1000 Imp/kWh (kvarh)
– Transformer rated meter	Red LED, 5000 Imp/kWh (kvarh)

### EIB connection:

Communication protocol:	ABB i-bus®, EIB (European Installation Bus) / KNX
Transmission medium:	Twisted twin-core cable, YCYM or J-Y(St)Y 2 x 2 x 0.8 mm
EMC:	Between meter and EIB terminals
– Surge voltage:	6 kV, 1.2/50 µs (IEC 255-4)
– Burst:	4 kV, 5/50 ns (IEC 801-4)
Operating and display elements:	
– ABB i-bus®, EIB/KNX terminal	Bus connection terminal supplied
– Red LED and push button	For entering the physical address

### Pulse output:

Terminals	For conductors with 0.2 to 2.5 mm <sup>2</sup> (combination meter max. 0.5 mm <sup>2</sup> )
Voltage	0-247 V AC/DC (any polarity)
Current	Max. 100 mA
Pulse length	100 ms
Pulse frequency	Adjustable

### Standards/norms:

Active energy meter, Class 1 and 2:	IEC 61036
Reactive energy meter, Class 2:	IEC 61268
ABB i-bus®, EIB / KNX:	EIB handbook release 3.0
PTB approval number:	20.15/04.28

## 2.2 Dimension drawings

Dimensions in mm

**EIB Delta-Meter Plus**  
Single-phase meter  
Polyphase meter  
Transformer rated meter  
Direct connected meter

### Transformer rated meters

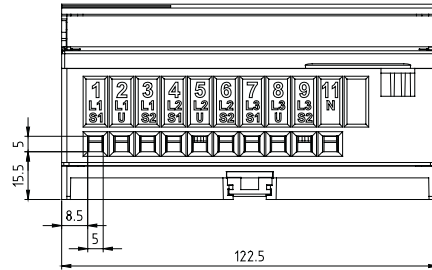

### Direct connected meters

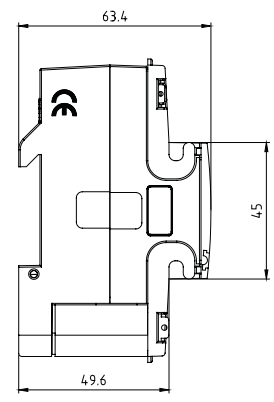
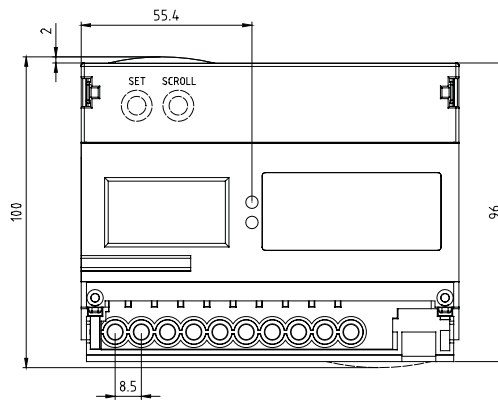
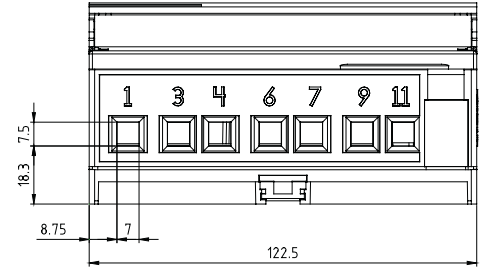

### Panel mounting kit

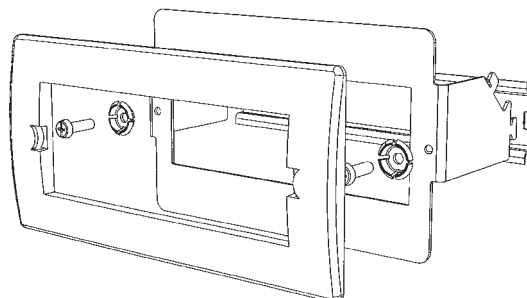
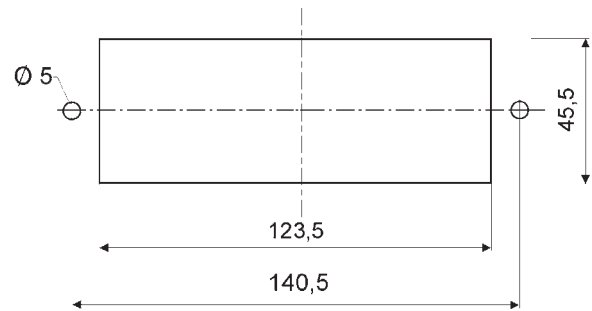
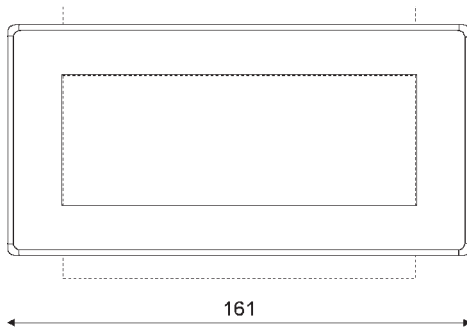

## 2.3 Important note

EIB Delta-Meters are intended solely for the measurement of electrical energy. The installation and commissioning may only be carried out by electrical specialists. The appropriate norms, guidelines, regulations and specifications should be observed when planning and setting up electrical installations.

### Advisory:

- EIB Delta-Meters should be protected from damp, dirt and damage during transport, storage and operation.
- EIB Delta-Meters should not be operated outside the specified technical data.
- Sufficient cooling for the EIB Delta-Meter must be allowed for.

**Cleaning:** If devices become dirty, they can be cleaned using a slightly damp cloth and soap solution should a dry cloth not remove the dirt. Corrosive materials or solutions should never be used. EIB Delta-Meters should always be disconnected from the supply prior to cleaning.

**Maintenance:** EIB Delta-Meters are maintenance-free. No repairs should be carried out if damage occurs (e.g. during transport or storage).

**The warranty expires if the EIB Delta-Meter is opened.**

## 2.4 Labelling of the EIB Delta-Meter (Example)

### Standard meters

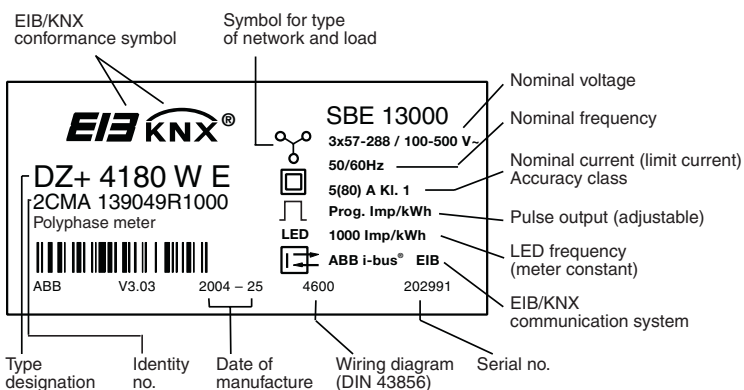

### PTB-zugelassene Zähler zusätzlich

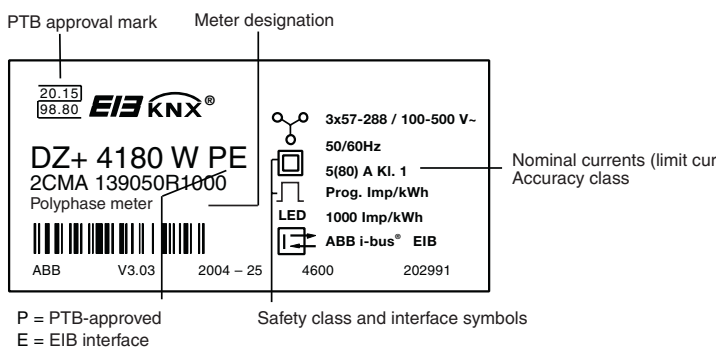

**3 Assembly and  
installation**

The EIB Delta-Meters are suitable for installation in distribution boards or small enclosures, for wall mounting or panel mounting. They can be snapped onto 35 mm mounting rails, according to DIN EN 60 715.

**Connection:** The electrical connection is carried out via screw terminals. The terminal markings and insulation strip lengths are embossed in the terminal area of the meter. (Wiring diagrams can be found in section 3.1). The connecting screws should be tightened using the following torque:

Main terminal:

- Direct connected meter (M5 screw) 2.0 Nm
- Transformer rated meter (M4 screw) 1.0 Nm

When connecting aluminium conductors, the contact surfaces of the conductors should be cleaned, brushed and greased. The connecting terminals should be re-tightened after approx. 6 to 8 weeks.

Maintenance procedures can be simplified by using external terminal blocks when connecting a transformer.

**Fuse protection:** The voltage circuit should be protected by a series-connected, miniature circuit-breaker, in order to prevent the meter from being damaged in the event of a short circuit or overload.

- Direct connected meter max. 80 A NH00 gL/gG
- Transformer rated meter max. 10 A circuit-breaker with B characteristic or gL/gG



**Seal:** To protect the EIB Delta-Meter from being tampered with after installation and programming, it is possible to seal the device at four points.

**3.1 Circuit diagrams (with schematic numbers in accordance with DIN 43 856)**

**Direct connected meter**

**Transformer rated meter**

**Two-wire, polyphase voltage network**

DZ+ 2280  
Direct measurement up to 80 A

DZ+ 2105  
Measurement with current transformer

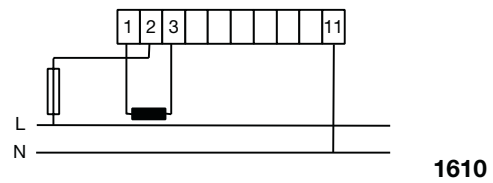
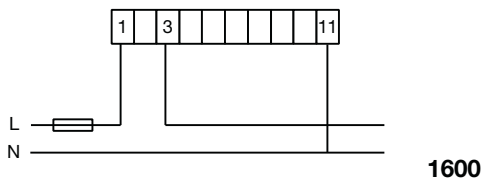

**Three-wire, polyphase voltage network, any load**

DZ+ 3280  
Direct measurement up to 80 A

DZ+ 3105  
Measurement with current transformers

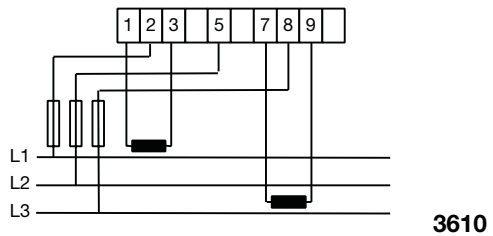
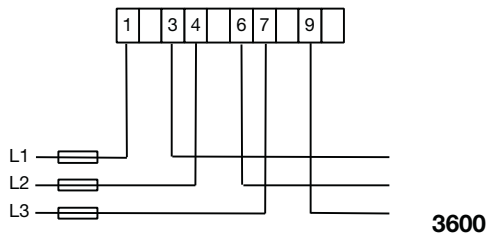

**Four-wire, polyphase voltage network, any load**

DZ+ 4180, DZ+ 4280  
Direct measurement up to 80 A

DZ+ 4105  
Measurement with current transformers

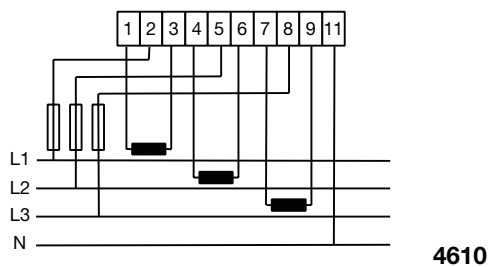
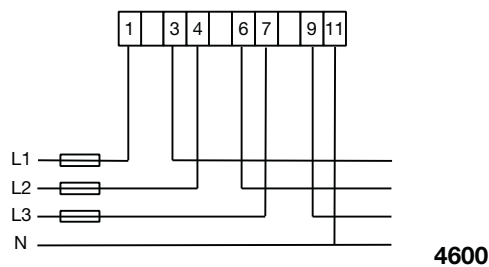

### 3.2 Adjustable values

All the settings start by pressing the SET button. You can find an overview of the settings in Chapter 4.4.

The hand symbol in the display flashes if the input mode is active.



Both the PTB-approved and standard EIB transformer rated meters have an adjustable transformation ratio. This ratio only influences the displayed values for the LCD display. Consumption and measured values are always transferred on the EIB as **secondary values**. If these values should be indicated on a display or visualisation terminal, they must be multiplied by the transformation ratio..

#### Setting the transformation ratio (Ct)\* of the current transformer

Step	Action	Display	Result
1	Press 1 x <b>S</b>	Ct 1	In SET mode
2	Press 1 x <b>S</b>	Ct-0	Hand symbol shows activation of the input mode, hand flashes
3	Press n x <b>Sc</b>	Ct -0	Changes the value of the number (increases by 1 each time it is pressed)
4	Press 1 x <b>S</b>	Ct -0n	Confirms the value and activates the next digit
5	Steps 4 – 5	Ct nnnn	Repeat steps 4-5 until the correct ratio is entered
6	Press 1 x <b>LSc</b>	Normal mode	Back to normal mode

$$*Ct = \frac{\text{Primary current } (I_p)}{\text{Secondary current } (I_s)}$$

This menu is only visible for transformer rated meters

#### Example

A meter is connected to a current transformer 500/5.  
The transformation ratio is 100.

Step	Action	Display	Result
1	Press 1 x <b>S</b>	Ct 1	In SET mode
2	Press 1 x <b>S</b>	Ct 1	Hand symbol shows activation of the input mode, hand flashes
3	Press 2 x <b>S</b>	Ct -000	Confirms 0 as the value for the last two digits. Activates the second digit.
4	Press 1 x <b>Sc</b>	Ct -100	Increases the value of the second digit by 1
5	Press 1 x <b>S</b>	Ct 0100	Activates the first digit
6	Press 1 x <b>S</b>	CT 100	Confirms the ratio is 100
7	Press 1 x <b>LSc</b>	Normal mode	Back to normal mode

## Setting the transformation ratio (Ut-)\* of the voltage transformer

Step	Action	Display	Result
1	Press 1 x <b>S</b>	Ct 1	In SET mode
2	Press 1 x <b>Sc</b>	Ut 1	In transformation ratio mode
3	Press 1 x <b>S</b>	Ut-0	Hand symbol shows activation of the input mode, hand flashes
4	Press 1 x <b>Sc</b>	Ut -n	Changes the value of the number (increases by 1 each time it is pressed)
5	Press 1 x <b>S</b>	Ut -0n	Confirms the value and activates the next digit
6	Step 4 – 5	Ut nnnn	Repeat steps 4-5 until the correct ratio is entered
7	Press 1 x <b>LSc</b>	Normal mode	Back to normal mode

$$*U_t = \frac{\text{Primary voltage } (U_p)}{\text{Secondary voltage } (U_s)}$$

This menu is only visible for transformer rated meters

### Example:

$$U_t = \frac{10,000}{100} = 100$$

## Setting the pulse frequency (P - -)

Step	Action	Display	Result
1	Press 1 x <b>S</b>	Ct 1	In SET mode
2	Press 1 x <b>Sc</b>	P nnnnn	In pulse frequency menu
3	Press 1 x <b>S</b>	P nnnnn	Hand symbol shows activation of the input mode, hand flashes
4	Press 1 x <b>Sc</b>	P nnnnn	Changes the pulse frequencies (press until the required pulse frequency appears)
5	Press 1 x <b>S</b>	P nnnnn	Confirms the value
6	Press 1 x <b>LSc</b>	Normal mode	Back to normal mode

### 3.3 Pulse outputs (S0)

The Delta-Meters are usually equipped with pulse meters (terminals 20 and 21) for the output of the active power. The DZ+ ends an adjustable number of pulses per kilowatt hour.

The pulse outputs are electrically isolated from the electronics of the meter and comply with both DIN 43 864 (also denoted as S0) and the IEC norm 62053-31.

The maximum voltage at the pulse outputs is 247 V AC/350 V DC while the maximum current is 100 mA. The equivalent circuit diagram of the pulse outputs appears as follows:

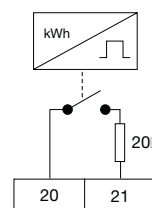

Standard meter

### Frequency and pulse length of the pulses

The pulse outputs send pulses according to the primary values of the meter. In the case of transformer rated meters, the set transformation ratio (Ct and Vt) is taken into account and the pulses are issued according to the primary values calculated using the ratio.

The pulse length of the pulse outputs is fixed at 100 ms.

The pulse frequency is adjustable (not possible for all meters). The following values are possible:

Direct connected meter: 1/10/100/500/640/1000/5000

Transformer rated meter: 0.01/0.1/1/10/100/500/640/1000

As the pulse length is fixed, it must be ensured when selecting the pulse frequency that the frequency is not set so high that a continuous signal is issued at the pulse output.

The following formula can be used for the calculation:

$$\text{Maximum pulse frequency} = 1000 * 3600 / U / I / n / (P_{\text{pause}} + P_{\text{width}})$$

U = Expected maximum primary value of the voltage (note Vt)

 I = Expected maximum primary value of the current (note Ct)

N = Number of measuring elements

(1...3, see also: chapter on measurement of energy)

Pwidth = Pulse length = 100 ms (fixed)

Ppause = Pause between 2 pulses

(should be at least 0.03 s = 30 ms to comply with the S0 standard)

### Example 1:

For a direct connected meter with 3 measuring elements and the maximum primary values of 250 V and 65 A, the maximum pulse frequency should be determined at a pulse length of 100 ms, so that the minimum pause of 30 ms between 2 pulses can be maintained.

$$\text{Maximum pulse frequency} = 1000 * 3600 / 250 / 65 / 3 / (0.030 + 0.100) = 568 \text{ pulses / kWh (kvarh)}$$

### Example 2:

For a transformer rated meter with 3 measuring elements and the maximum primary values  $63 * 100 \text{ V} = 6300 \text{ V}$  (VT = 100) and  $6 * 50 \text{ A} = 300 \text{ A}$  (CT = 50), the maximum pulse frequency should be determined at a pulse length of 100 ms, so that the minimum pause of 30 ms between 2 pulses can be maintained.

$$\text{Maximum pulse frequency} = 1000 * 3600 / 6300 / 300 / 3 / (0.030 + 0.100) = 6.16 \text{ pulses / kWh (kvarh)}$$

### 4 Function and operation

#### 4.1 LCD display

In addition to the energy consumption values, the multifunctional LCD display shows the user the parameters outlined below.

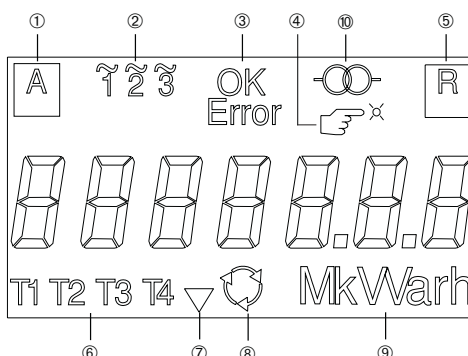

- ① **Active power indicator:** The symbol flashes dependent on the instantaneous active power consumption.  
 Direct connected meter: 1000 Imp/kWh  
 Transformer rated meter: 5000 Imp/kWh
- ② **Voltage indicators:** The symbols L1, L2 and L3 are constantly lit if the corresponding phase voltage has been connected.  
**Note:** In the case of three-wire, polyphase meters, only voltage indicators L1 and L3 normally light up.
- ③ **Status indicator:** The text indicates whether the device is 'OK' or there is an 'Error', i.e., device or installation errors present.
- ④ **Operational indicator:** The 'Hand' symbol lights up if a push button action is expected.
- ⑤ **Reactive power indicator:** The symbol flashes dependent on the instantaneous reactive power consumption.  
 Direct connected meter: 1000 Imp/kvarh  
 Transformer rated meter: 5000 Imp/kvarh
- ⑥ **Tariff indicators:** The symbols T1, T2, T3 and T4 indicate the active tariff and the tariff that is currently on the LCD display.  
 No symbol is lit – The sum of all tariffs is displayed.  
 Only TX flashes – Tariff X is active and is displayed.  
 TX flashes and TY is constantly lit – Tariff X is active, tariff Y is displayed.
- ⑦ **Mode indicator:** The arrow symbol changes with the display mode.  
 No arrow – 'Normal mode'  
 Arrow lights up – 'Alternative mode'  
 Arrow flashes – 'Instrument mode'
- ⑧ **Function indicator:** The arrow symbols rotate at a constant speed, if the current lies in at least one phase above the starting current.  
**Note:** The arrows rotate even if the direction of current flow is incorrect.
- ⑨ **Unit of measurement:** Indicates the unit of the measured value in the LCD display.
- ⑩ **Transformer indicator:** Indicates that the transformer rated meter is using a transformation ratio ( $\neq 1$ ).

**Displayed energy:** The meter reading is indicated on the LCD display. In “Alternative mode”, the consumption value is displayed with an additional decimal place after the point.

In the case of combination meters, the displayed consumption value alternates approx. every 6 seconds between active and reactive power. The type of value can be seen by the unit of measurement, i.e., kWh or kvarh.

In the case of tariff meters, the displayed consumption value also alternates approx. every 6 seconds between each of the four tariffs and the sum of the tariffs. Using the tariff indicators, it can be determined which tariff value is currently being shown.

**Note:** The measurement of energy consumption takes place in all display and programming modes. In the event of voltage failure or disconnection of the device, the current measured consumption value is maintained, in spite of the LCD display being inactive.

### 4.2 Light sensor

The EIB Delta-Meters have a light sensor). This has the same function as the ‘SCROLL’ button if a torch for example is shone on the sensor. This enables the meter readings to be queried both in the case of programmed devices and installed or sealed devices.

**It is not possible to modify any settings with the light sensor.**

### 4.3 Programming buttons

The various read-out options of the EIB Delta-Meter are activated using a menu-driven software. This menu is operated via two buttons:

**‘SET’ button:** It is used to change between “Display mode” and “Set mode”.

**‘SCROLL’ button:** It has two different functions depending on the length of the push button action:

- When the ‘SCROLL’ button is pressed briefly, you can jump between the individual items in the respective menu.
- A long push button action (> 3s) switches from ‘Normal mode’ to ‘Alternative mode’ and from ‘Alternative mode’ to ‘Instrument mode’. In all other modes, a long push button action acts as a “Escape” function. (The software jumps back one menu level).

**Only one button may be pressed at a time.**

**The commands are only carried out once the button has been released.**

If no buttons are pressed for two minutes during the programming, the EIB Delta-Meter cancels the action and jumps back one menu level. This is repeated until the meter is in ‘Normal mode’.



## 4.4 Indicators in the display

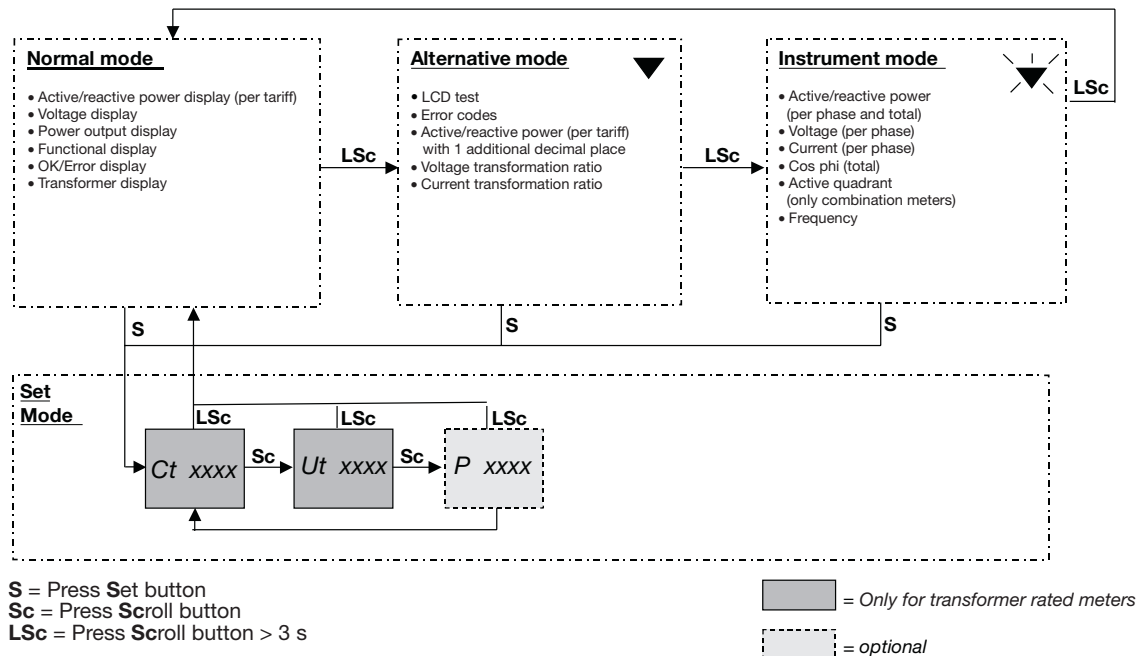

## 4.5 Installation self-test

The installation self-test checks the connection and wiring of EIB Delta-Meters and can detect the following installation errors:

- current or voltage connections that are missing or have reverse polarity
- current, voltage or frequency values that are outside the specified tolerance
- internal errors

The installation self-test is carried out automatically approx. every 8 seconds. If device or installation errors occur, they are reported on the LCD display with the 'Error' signal.

To simplify the fault rectification process, the various types of errors are also displayed as installation error codes. These errors can be read out in "Alternative mode". A detailed description of the error codes and notes on remedying the fault can be found in Chapter 6.2.

**Note:** So that the EIB Delta-Meters can successfully carry out the installation self-test, the meter must be connected with all phases and there must be a load current of at least 100 mA per phase in the secondary circuit.

**4.6 Reading out the error codes** To read out the error codes when starting from **Normal mode**, it is necessary to carry out the push button actions in the sequence described. The descriptions should be used in connection with the explanations about the indicators on the display in Chapter 4.4.

- Press the SC button for more than 3 seconds
- When the button is released, you go into "Alternative mode" (see 4.4)
- A display test is first carried out i.e. all the available symbols are shown in the display
- After 4 seconds, the display automatically changes to the next entry – the error code. You can also browse through "Alternative mode" by pressing the SC button briefly and view the error codes one after the other
- You can find an explanation about the error codes in the appendix

**4.7 Network monitoring function**

All electrical measured variables, which are measured by the EIB Delta-Meter in order to record the energy consumption, can be displayed on the LCD display. These values can be used for network monitoring and servicing purposes. The following table indicates which measured variables are available depending on the EIB Delta-Meter.

- W** – Active energy meter
- T** – Tariff meter
- K** – Combination meter

The electrical measured variables are generally displayed in the following format on the LCD display:

- Ux XXX.X V** U = Measured variable, e.g., voltage (U), current (A)
- x = Phase (1, 2, 3) or Total value (t)
- XXX.X = Measured value
- V = Unit of measurement

Measured variables	Meter type			Format	Unit	Example	Comment
	W	T	K				
Active power L1, L2, L3, Σ	■	■	■	Px XXXX Px XX.XX	W kW	P1 1250 W P2 14.50 kW	< 10.000 W ≥ 10.000 W
Reactive power L1, L2, L3, Σ			■	Px XXXX Px XX.XX	var kvar	P3 35 Var Pt 1.50 kVar	< 10.000 var ≥ 10.000 var
Voltage L1-N, L2-N, L3-N (L1-L2, L2-L3) <sup>1</sup>	■	■	■	Ux XXX.X	V	U1 230.4 V	<sup>1</sup> Three-wire meter
Current L1, L2, L3	■	■	■	Ax XX.XX	A	A3 22.93 A	
Power factor L1, L2, L3, Σ	■ <sup>2</sup>	■ <sup>2</sup>	■	Pfx X.XX		Pf1 0.95	<sup>2</sup> Only total power factor. The total power factor is calculated from the total active and reactive power. The power factor is positive in the first and fourth quadrants (active power consumption) and negative in the second and third quadrants.
Frequency	■	■	■	Fr XX.XX	Hz	Fr 50.03	

The measured variables are measured again approx. every 5 seconds and can either be read out in 'Instrument mode'.

The measuring accuracy of all the values corresponds to the requirements of the norm IEC61036 within the supply voltage tolerance of ± 20 % and the current range of 0.05 I<sub>b</sub> (nominal current) to I<sub>max</sub> (limit current).

## 5 Parameterisation in ETS

### 5.1 General

Depending on the type of meter, the following three application programs are available for the EIB Delta-Meter electricity meters:

- Active energy meter/1.1
- Tariff meter/1.1
- Combination meter/1.1



Both the PTB-approved and standard EIB transformer rated meters have an adjustable transformation ratio. This ratio only influences the displayed values for the LCD display. Consumption and measured values are always transferred on the EIB as secondary values. If these values should be indicated on a display or visualisation terminal, they must be multiplied by the transformation ratio.

**Active energy meter/1.1:** The application software “Active energy meter/1.1” can be used for all EIB Delta-Meter electricity meters except for the tariff and combination meters. This applies irrespective of other meter properties (e.g. whether the meter is a direct connected or transformer rated meter, is used for two-, three- or four-wire systems or which operating voltage the meter is connected to). The application software enables the transfer of the meter reading with various transmission procedures as well as the transfer of the instantaneous power and the status of the meter via the ABB i-bus® EIB.

**Tariff meter/1.1:** The application software “Tariff meter/1.1” is used with all tariff meters that have EIB capability, i.e., the following meter types:

DZ+ 4105 WT E  
 DZ+ 4280 WT E  
 DZ+ 4105 WT PE  
 DZ+ 4280 WT PE

In addition to transferring the meter readings (4 tariffs and sum), the meter status and instantaneous power, the tariffs can be controlled via the ABB i-bus® EIB with this application software.

**Combination meter/1.1:** The following combination meters are programmed using the application software “Combination meter/1.1”:

DZ+ 4105 K E  
 DZ+ 4280 K E  
 DZ+ 4105 K PE  
 DZ+ 4280 K PE

This application software enables the meter reading and instantaneous power to be read out via the ABB i-bus® EIB. This applies to the proportion of both active and reactive power consumption.

ETS2 from Version 1.2b or a newer version of ETS (e.g. ETS2 V1.3) is used for the programming.



The EIB Tool Software ETS2 V1.1 without Service Release B or higher does not program DZ+ correctly.

It is therefore necessary to install Service Release B or higher on the commissioning PC before programming the application software. If this is not carried out, the device cannot function and can no longer be programmed. Service Release B or higher is available on the ABB CD-ROM and on the Internet page [www.eiba.com](http://www.eiba.com).

## 5.2 Communication objects

The three application programs “Active energy meter/1.1”, “Tariff meter/1.1” and “Combination meter/1.1” have various communication objects according to the functionality of the EIB Delta-Meter (see graphic).

Many of the communication objects are dynamic and only visible if the corresponding parameters have been activated in the application software. These communication objects are inactive or disabled at the start of the project design process. Only one group address can be assigned to each communication object.

Building View [EIB Delta-Meter]										
Building		Building part		Room		Device		Show Objects		
Phys. Addr.	Product	Order number	Medium Type	Program	Manufacturer					
no.	Function	Object name	Type							
01.01.001	EIB Delta-Meter	GHQ 630 1752 R0001	Twisted Pair	Active Energy Meter/1.1	ABB					
0	Output Telegram	Meter Reading, Active Energy	4 Byte							
1	Output Telegram	Instantaneous Power	2 Byte							
2	Input Telegram	Request Meter Reading	1 Bit							
3	Output Telegram	Fault	1 Bit							
4	Output Telegram	Status Byte	1 Byte							
5	Output Telegram	Communication Fault	1 Bit							
6	Input Telegram	Acknowledgement "Meter Reading Received"	1 Bit							
7	Input Telegram	Fault Acknowledgement	1 Bit							
01.01.002	EIB Delta-Meter	GHQ 630 1752 R0001	Twisted Pair	Tariff Meter/1.1	ABB					
0	Output Telegram	Meter Reading, Total	4 Byte							
1	Output Telegram	Meter Reading, Tariff 1	4 Byte							
2	Output Telegram	Meter Reading, Tariff 2	4 Byte							
3	Output Telegram	Meter Reading, Tariff 3	4 Byte							
4	Output Telegram	Meter Reading, Tariff 4	4 Byte							
5	Output Telegram	Instantaneous Power	2 Byte							
6	Input Telegram	Request Meter Readings	1 Bit							
7	Input Telegram	Switch Tariff	1 Byte							
8	Output Telegram	Fault	1 Bit							
9	Output Telegram	Status Byte	1 Byte							
10	Output Telegram	Communication Fault	1 Bit							
11	Input Telegram	Acknowledgement "Meter Reading Received"	1 Bit							
12	Input Telegram	Fault Acknowledgement	1 Bit							
01.01.003	EIB Delta-Meter	GHQ 630 1752 R0001	Twisted Pair	Combination Meter/1.1	ABB					
0	Output Telegram	Meter Reading, Active Energy	4 Byte							
1	Output Telegram	Meter Reading, Reactive Energy	4 Byte							
2	Output Telegram	Instantaneous Active Power	2 Byte							
3	Output Telegram	Instantaneous Reactive Power	4 Byte							
4	Output Telegram	Instantaneous Reactive Power	2 Byte							
5	Output Telegram	Reactive Power Type	1 Bit							
6	Input Telegram	Request Meter Readings	1 Bit							
7	Output Telegram	Fault	1 Bit							
8	Output Telegram	Status Byte	1 Byte							
9	Output Telegram	Communication Fault	1 Bit							
10	Input Telegram	Acknowledgement "Meter Reading Received"	1 Bit							
11	Input Telegram	Fault Acknowledgement	1 Bit							

**Meter reading [EIS 11; 32 bit counter]:** The measured energy consumption values or meter readings are transferred via the 4 byte output communication object “Meter reading”. The application software “Tariff meter/1.1” has five meter reading objects altogether, one for each of the four tariffs and one for the total. The application software “Combination meter/1.1” has one object for the active energy and one for the reactive energy. The transmitted data correspond to the values that are displayed on the LCD display. The sending behaviour of these objects is defined in the parameter window “Meter readings”.

Object type	Measuring range	Resolution	Unit
4-Byte	0 .. 999 999 990	10 Wh (varh)	Wh (varh)

**Instantaneous power (active/reactive) [EIS 10; 16 bit counter]:** The 2 byte output communication object “Instantaneous power” is used to transfer the instantaneous power or energy consumption. The sending behaviour of these objects is defined in the parameter window “Instantaneous power”.

Object type	Measuring range	Resolution	Unit
2-Byte	0 .. 65534 (65535 = Überlast)	1 W (var)	W (var)

The application software “Combination meter/1.1” has separate communication objects for the instantaneous active power and the instantaneous reactive power. In addition, it is possible to transfer the reactive power as:

- a 2 byte object [EIS 10; 16 bit counter] (see above) with a separate “Reactive power type” [EIS 1; switching] object in order to transfer the type of reactive power.  
Telegram value “0”: inductive reactive power  
Telegram value “1”: capacitive reactive power
- or as a 4 byte object with sign [EIS 11; 32 bit counter].

Object type	Measuring range	Resolution	Unit
4-Byte	- 65534 ..... + 65534	1 var	var

If the actual instantaneous power lies above 65534 W (var), the value 65535 (FF FF<sub>h</sub> or 7F FF FF FF<sub>h</sub> for the 4 byte object) is sent as an “overload signal”.

**Request meter reading [EIS 1; switching]:** The read request for the current meter readings of the EIB Delta-Meter is transferred to the meter via the 1 bit input communication object “Request meter reading”. Once a request signal telegram with the value “1” has been received, the meter reading is stored and sent on the bus once the transmission delay  $T_w$  has elapsed (if selected). This sending behaviour is defined in the parameter window “Meter readings”.

The communication object is only visible if the option “Send on request” is selected.

Telegram value “1”: Send meter reading  
“0”: No function

**Switch tariff [EIS 14; 8 bit counter]:** The 1 byte input communication object “Switch tariff” enables the control of four different tariffs of an EIB Delta-Meter tariff meter via the ABB i-bus® EIB. On receipt of a valid object value (1, 2, 3 or 4), the meter switches to the required tariff. Once the transmission delay  $T_w$  has elapsed (if selected), the current data of the old and new tariffs as well as the total of all the tariffs at the time of the change are sent on the bus.

Telegram value	“1”:	Switch to tariff 1
	“2”:	Switch to tariff 2
	“3”:	Switch to tariff 3
	“4”:	Switch to tariff 4
	“other values”:	no function

Approximately 6 seconds after a reset or bus voltage recovery, the actual status of the communication object “Switch tariff” is queried via the bus. Once a response has been received, a corresponding tariff change is carried out and the current data and total of all the tariffs is sent on the bus. However, if there is no response after approximately a further 4 seconds, the meter switches to the last selected tariff (prior to the reset or bus voltage failure) and the data is sent. To guarantee this function the ‘update flag’ of the “switch tariff” communication object must be set to active (default setting).

The tariff control signal from the power supply company can be decoupled via a ripple-control relay and made available to the EIB via floating contacts (one per tariff). To generate the required 8-bit values for changing the tariff from this binary information, it is possible e.g. to use a binary input with the corresponding application software.

**Acknowledgement “Meter reading received” [EIS 1; switching]:** If the function “Active acknowledgement “Meter reading received”” is activated, the EIB Delta-Meter expects an acknowledgement from the receiving EIB devices after *each* transmission of a meter reading. This confirms that the data has reached the recipient. If no acknowledgement is received after approx. 2 seconds after the meter reading has been sent, the transmission is repeated. The 1 bit input communication object is only visible if the parameter “Active acknowledgement “Meter reading received”” in the parameter window “Meter readings” is activated.

Telegram value	“1”:	Meter reading received
	“2”:	No function

**Communication fault [EIS 1; switching]:** If the EIB Delta-Meter has not received a telegram at the communication object “Acknowledgement “Meter reading received”” after sending the meter reading twice (see above), a telegram is sent from the 1 bit output communication object “Communication fault” to signal that there is a transmission fault. If a subsequent transmission of the meter reading is acknowledged correctly, this error message is removed. The communication object is only visible if the parameter “Active acknowledgement “Meter reading received”” in the parameter window “Meter readings” is activated.

Telegram value	“1”:	Communication fault
	“0”:	No communication fault

**Fault [EIS 1; switching]:** The 1 bit output communication object “Fault” sends the state of the EIB Delta-Meter via the ABB i-bus® EIB in the form of a group error message. An error message can have several causes and can be decoded with the help of the communication object “Status byte” or by reading out the error codes in the meter (see section 5.8). The sending behaviour of these objects is defined in the parameter window “Status”.

Telegram value	“1”:	Fault
	“0”:	No fault

**Fault acknowledgement [EIS 1; switching]:** The 1 bit input communication object enables the EIB Delta-Meter to be reset after an error has occurred and is only visible if the parameter “Fault acknowledgement” in the parameter window “Status” is activated. The error message is only reset after an acknowledgement if all the errors have previously been rectified.

Telegram value      “1”: Reset error message  
                             “0”: No function

**Status byte [Non EIS; 8 bit coded]:** Each EIB Delta-Meter has a 1 byte output communication object “Status byte” which can send the various status information of the meter via the ABB i-bus® EIB. Each individual bit of the 1 byte telegram corresponds to a specific meter state or error type. Whenever a new error is detected, the corresponding bit is set and the status byte is sent on the bus (if selected). The sending behaviour of this object is defined in the “Status” parameter window. The following applies for all the bits:

Bit value              “1”: Error  
                             “0”: No error

The following table represents the connection between the individual bits, the error type and the error codes in the meter.

Bit	Error type	Equivalent error code (see section 6.2 “Error codes”)
0 (LSB)	Phase voltage error	100, 101, 102
1	Overvoltage	103, 107, 111
2	Undervoltage	104, 108, 112
3	Overload	105, 109, 113
4	Frequency error	115, 116
5	Installation error	118, 119, 120, 121, 122
6	Negative active power	123, 124, 125, 126
7 (MSB)	Internal error	127, 128, 129 and unmentioned error codes

The status byte key table in section 5.8 enables the transmitted status byte value to be quickly converted to the individual error types.

### 5.3 Parameter options

During the initial configuration of the application software “Active energy meter/1.1”, “Tariff meter/1.1” and “Combination meter/1.1”, the parameter options are pre-programmed with a specific basic setting (in general, they are set to inactive or disabled).

To avoid a high bus load, it is important to only activate functions and parameters that are actually required. When selecting cyclic times or setting the sending behaviour dependent on variable measured values, the resulting bus traffic must also be taken into consideration to avoid communication problems.

The reaction of the EIB Delta-Meter to a Reset or the restoration of the bus voltage is dependent on the application software used and the parameter settings. This is described in detail in the respective sections concerning the communication objects, the parameter options and the parameter windows.

**5.4 Parameter window: General** The sending interval of the EIB Delta-Meter is defined in the “General” parameter window.

**Transmission delay:** To prevent any possible communication problems due to the simultaneous transmission of meter data, e.g., in installations where several EIB Delta-Meters are used and/or where communication takes place via area or line couplers, it is possible to send the telegrams of different meters with a time delay using the parameter “Transmission delay”. The delay influences the sending of the following telegrams: “Meter reading”, “Fault” and “Status byte”.

If “no” is selected, telegrams are sent without a delay via the ABB i-bus® EIB, i.e., telegrams are sent immediately after a meter reading request via the communication object “Request meter reading” is received or after a change in the fault status of the EIB Delta-Meter (if selected).

If “yes” is selected, information is sent after each meter reading request or change in the fault status via the ABB i-bus® EIB once a set period  $T_W$  has elapsed. The transmission delay  $T_W$  (tolerance  $\pm 1.5\%$ ) is produced from the set values:

$$\text{Transmission delay } T_W = \text{“Device number”} \times \text{“Base delay time”}$$

In this way, it is possible to assemble groups of EIB Delta-Meters (up to 128 per group) with the same base delay time. A number is assigned to each of the Delta-Meters in the group using the parameter “Device number”. In the event of a simultaneous meter reading request via the communication object “Request meter reading”, the meters send their values in sequence according to their device number via the ABB i-bus® EIB.

If the options “Transmission delay” and “Send cyclically” are activated at the same time, the sending of the meter reading telegrams is only delayed once directly after a reset, bus voltage recovery or after a tariff change, i.e., after each of these events, the meter waits until the set transmission delay  $T_W$  has elapsed until it starts to send the telegrams cyclically. With each subsequent transmission, only the cyclic time is observed since the meters are already sending with a time delay with respect to one another.

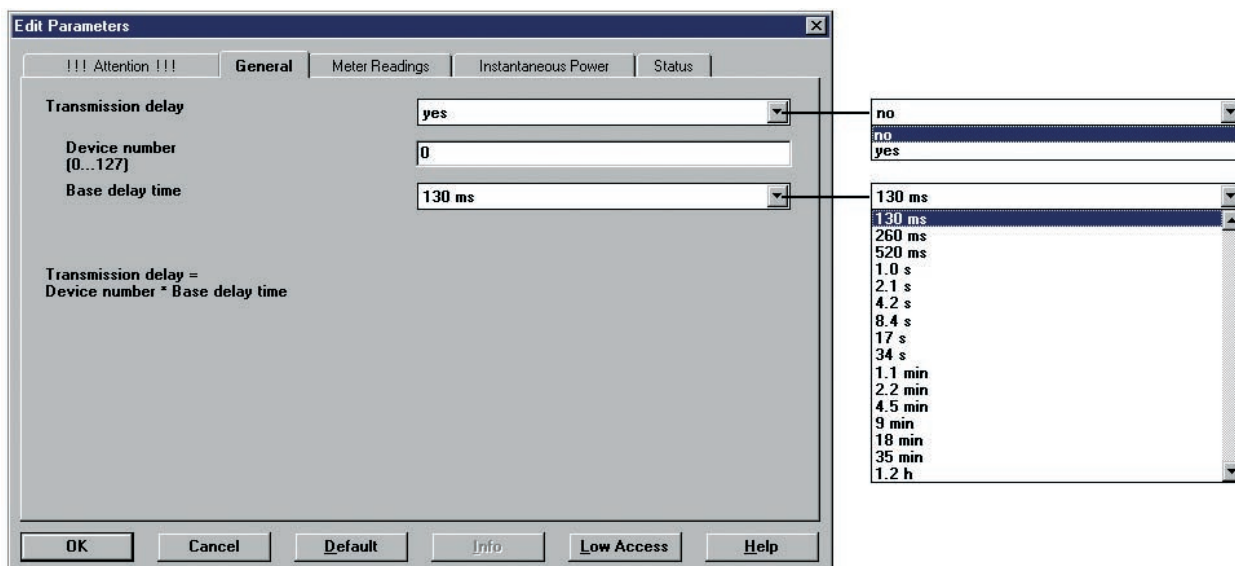

Default settings are highlighted

## 5.5 Parameter window: Meter readings

The sending behaviour of the communication objects “Meter reading” is defined in the parameter window “Meter readings”.

**Do not send:** If this setting is selected, the EIB Delta-Meter does not automatically send its meter reading on the bus. It is only possible to read out the current meter readings by reading out the object values via “Value\_Read”, e.g., using the EIB Tool Software ETS. The meter readings are updated every 8 seconds.

**Send cyclically:** In this setting, the meter readings are sent cyclically via the ABB i-bus® EIB. The sending interval (tolerance  $\pm 1.5\%$ ) is defined with the parameter “Period”. If several meters have the same cyclic time, they can send with a time delay  $T_W$  (if selected), in order to avoid possible communication problems.

**Send on request:** This setting enables the current meter readings to be actively read out using the communication object “Request meter reading”. Once a request telegram with the value “1” has been received, the meter reading is stored and sent after the transmission delay  $T_W$  (if selected) via the ABB i-bus® EIB. The transmission delay  $T_W$  prevents telegrams from being sent simultaneously if several meters react to the same meter reading request telegram.

**Active acknowledgement “Meter reading received”:** With the settings “Send cyclically” and “Send on request”, the user can choose to send with or without a receipt confirmation. If “yes” is selected, the EIB Delta-Meter expects to receive an acknowledgement telegram via the communication object “Acknowledgement “Meter reading received”” after *each* transmission of a meter reading. If an acknowledgement is not received after approx. 2 seconds, the meter reading is sent again. If the second repetition is not acknowledged, an error message is sent via the communication object “Communication fault”. During this period, the stored meter readings are maintained. They are only updated once a transmission has been acknowledged or a communication fault has been reported.

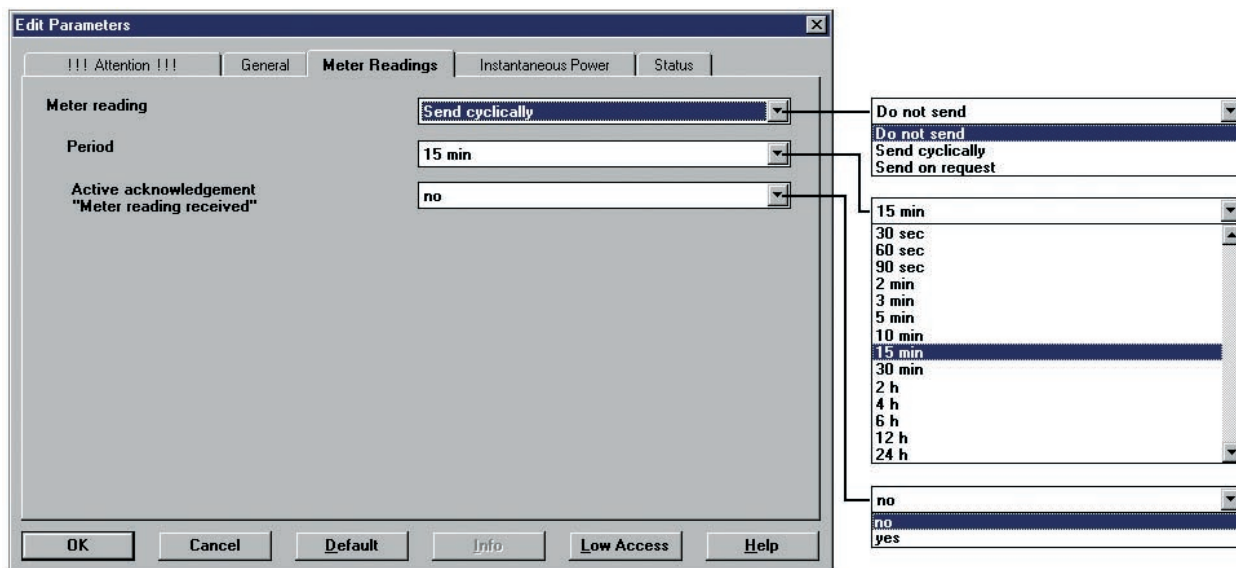

Default settings are highlighted

## 5.6 Parameter window: Instantaneous power

The sending behaviour of the communication objects “Instantaneous power” is defined in the parameter window “Instantaneous power”.

**Send instantaneous active/reactive power:** If “yes” is selected, the instantaneous power is transmitted on the bus. These values are updated every 8 seconds.

**Send reading on change of more than +/-:** The instantaneous power is sent via the ABB i-bus® EIB as a 2 byte telegram (also 4 byte for reactive power). In order to reduce telegram traffic, e.g., in installations where the energy consumption frequently fluctuates around an average value, the instantaneous power is only sent when there is a defined change compared to the last sent value. The size of this change can be set as a parameter. In the setting +/- 0 W (var), the new value is sent every 8 seconds.

**Note:** With large set values, the current instantaneous power can differ considerably from the last sent value.

After a reset or a restoration of the bus voltage, the instantaneous power will also only be sent on the EIB once the set difference value has been exceeded.

**Reactive power to be sent as:** Since the reactive power can be represented as both a positive value (inductive) and a negative value (capacitive), the combination meter also sends the reactive power type in addition to the measured value of the instantaneous power. In the setting “EIS 10 (2 byte value) and EIS 1 (sign)”, the polarity information is transmitted with a separate 1 bit telegram via the communication object “Reactive power type”. If the setting “EIS 11 (32 bit signed integer)” is selected, the power and the polarity information are sent in the form of a single 4 byte telegram.

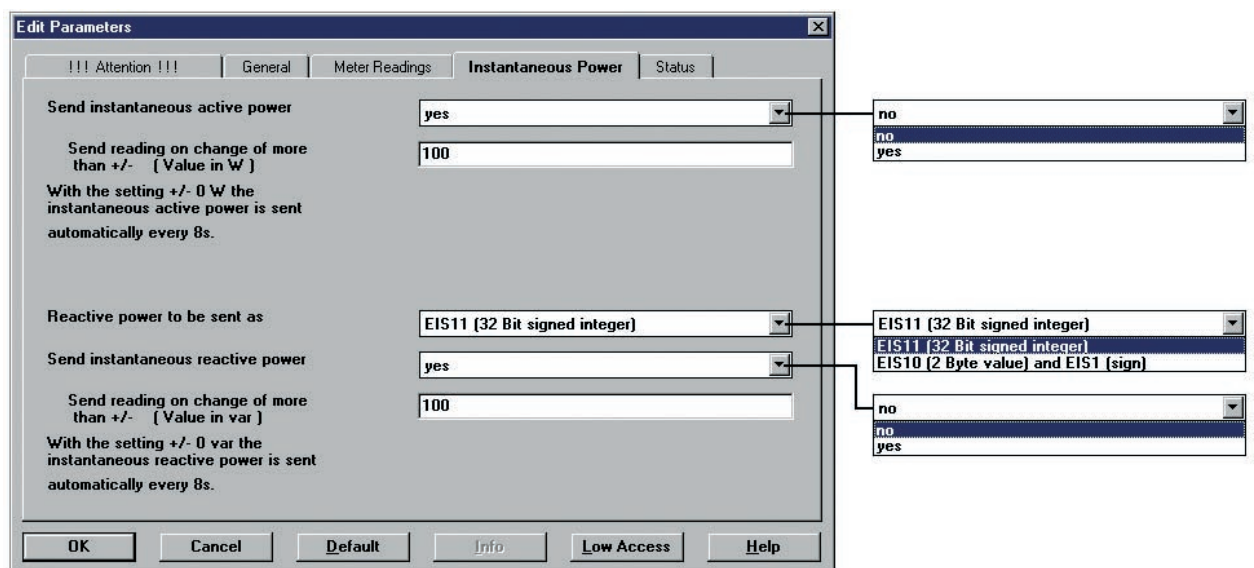

Default settings are highlighted

## 5.7 Parameter window: Status

The behaviour of the communication objects “Fault”, “Fault acknowledgement” and “Status byte” is defined in the “Status” parameter window.

**Fault acknowledgement:** If “no” is selected, a telegram is sent via the communication object “Fault” via the ABB i-bus® EIB after the first occurrence of a fault in the meter and once the transmission delay  $T_w$  has elapsed (if selected). The corresponding bits in the status byte object are set at the same time. These bits are set or reset after each new fault or after each removal of an fault. If all faults have been rectified, a telegram with the value “0” is sent automatically via the communication object “Fault”.

If “yes” is selected, a telegram is also sent via the communication object “Fault” via the ABB i-bus® EIB after the first occurrence of a fault in the meter. This error message remains set however until all the faults are rectified and the error message has been reset via the communication object “Fault acknowledgement”. The corresponding bits in the status byte object are also set after the first occurrence of a specific fault and remain set until the relevant fault is rectified and an acknowledgement telegram has been received via the communication object “Fault acknowledgement”.

**Send status byte on fault:** If the setting “no” is selected, the status byte is not automatically sent via the ABB i-bus® EIB. In order to receive the current value of the status byte, the object value must be read out by “Value\_Read”, e.g., using the EIB Tool Software ETS.

If “yes” is selected, the status byte is sent after each change via the communication object “Status byte” via the ABB i-bus® EIB, once the transmission delay  $T_w$  has elapsed (if selected)

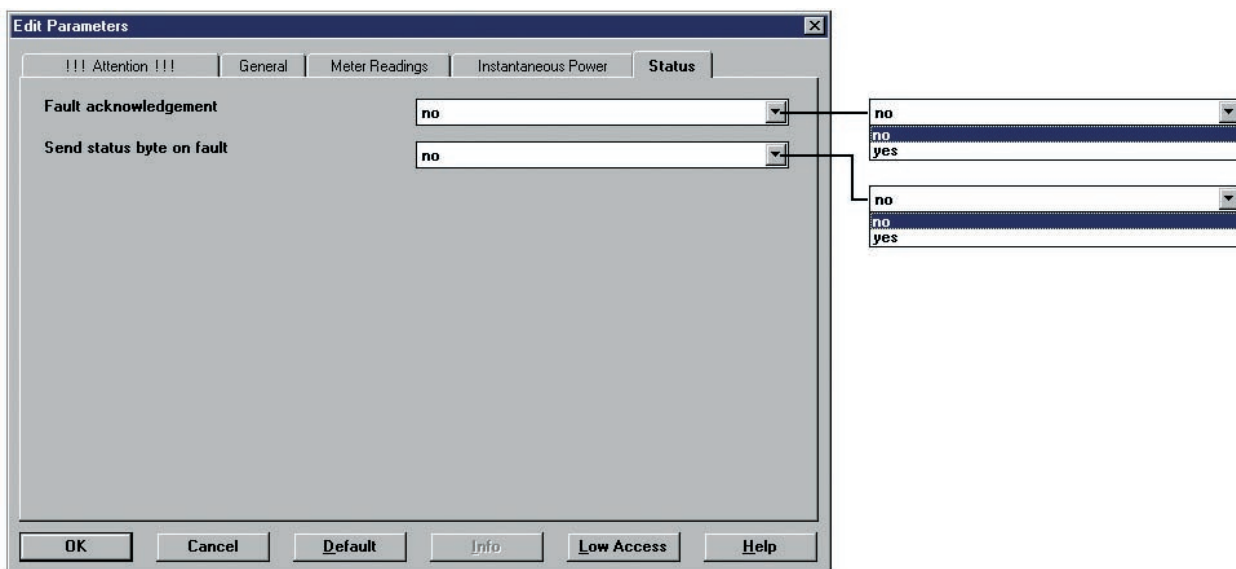

Default settings are highlighted

## 5.8 Status byte key table

Status byte value	Internal error	Negative active power	Installation error	Frequency error	Overload	Undervoltage	Overvoltage	Phase voltage error
0								
1								
2								
3								
4								
5								
6								
7								
8								
9								
10								
11								
12								
13								
14								
15								
16								
17								
18								
19								
20								
21								
22								
23								
24								
25								
26								
27								
28								
29								
30								
31								
32								
33								
34								
35								
36								
37								
38								
39								
40								
41								
42								
43								
44								
45								
46								
47								
48								
49								
50								
51								
52								
53								
54								
55								
56								
57								
58								
59								
60								
61								
62								
63								
64								
65								
66								
67								
68								
69								
70								
71								
72								
73								
74								
75								
76								
77								
78								
79								
80								
81								
82								
83								
84								
85								

Status byte value	Internal error	Negative active power	Installation error	Frequency error	Overload	Undervoltage	Overvoltage	Phase voltage error
86								
87								
88								
89								
90								
91								
92								
93								
94								
95								
96								
97								
98								
99								
100								
101								
102								
103								
104								
105								
106								
107								
108								
109								
110								
111								
112								
113								
114								
115								
116								
117								
118								
119								
120								
121								
122								
123								
124								
125								
126								
127								
128								
129								
130								
131								
132								
133								
134								
135								
136								
137								
138								
139								
140								
141								
142								
143								
144								
145								
146								
147								
148								
149								
150								
151								
152								
153								
154								
155								
156								
157								
158								
159								
160								
161								
162								
163								
164								
165								
166								
167								
168								
169								
170								
171								

Status byte value	Internal error	Negative active power	Installation error	Frequency error	Overload	Undervoltage	Overvoltage	Phase voltage error
172								
173								
174								
175								
176								
177								
178								
179								
180								
181								
182								
183								
184								
185								
186								
187								
188								
189								
190								
191								
192								
193								
194								
195								
196								
197								
198								
199								
200								
201								
202								
203								
204								
205								
206								
207								
208								
209								
210								
211								
212								
213								
214								
215								
216								
217								
218								
219								
220								
221								
222								
223								
224								
225								
226								
227								
228								
229								
230								
231								
232								
233								
234								
235								
236								
237								
238								
239								
240								
241								
242								
243								
244								
245								
246								
247								
248								
249								
250								
251								
252								
253								
254								
255								

**6 Appendix**

**6.1 Measurement of energy**

**6.1.1 Basic measurement techniques**

Various measurement methods are used in the EIB Delta-Meters depending on the type of meter. The following equations are vector equations.



**Measurement method with one measuring element**

This method only produces the correct result if the phase load is symmetrical.

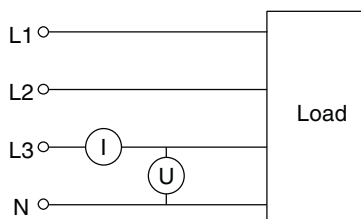

$$P = 3 \cdot I_{L3} \cdot U_{L3}$$

This method is not suitable for carrying out accurate measurements in polyphase voltage networks as 100% symmetrical loading seldom occurs.



**Measurement method with two measuring elements**

This method is used in polyphase voltage networks without a neutral conductor (three-wire network) with symmetrical or asymmetrical loading.

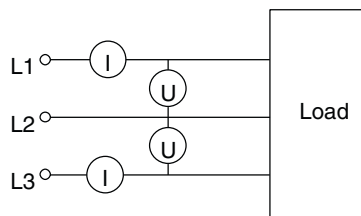

$$P = U_{L1} \cdot I_{L1} + U_{L2} \cdot I_{L2} + U_{L3} \cdot I_{L3}$$

$$\Sigma I = I_{L1} + I_{L2} + I_{L3} = 0$$

$$P = U_{L1} \cdot I_{L1} - U_{L2} (I_{L1} + I_{L3}) + U_{L3} \cdot I_{L3}$$

$$P = I_{L1}(U_{L1} - U_{L2}) + I_{L3}(U_{L3} - U_{L2})$$

This method (with 2 measuring elements) is not suitable for carrying out accurate measurements in networks with inductive or capacitive loads with a low  $\cos \varphi$ . In this case, the method that uses 3 measuring elements should be selected.



**Measurement method with three measuring elements**

This method is used in polyphase voltage networks with a neutral conductor (four-wire network). It can however also be used in networks without a neutral conductor, provided that an artificial neutral point is created.

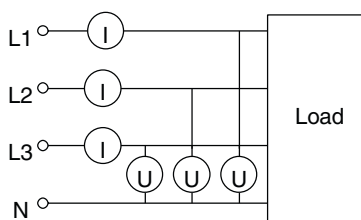

$$P = U_{L1} \cdot I_{L1} + U_{L2} \cdot I_{L2} + U_{L3} \cdot I_{L3}$$

This method is very accurate, even in the case of asymmetrical loads and low  $\cos \varphi$ .

## EIB Delta-Meter Plus Electricity Meters

**Active and reactive power:** Capacitive or inductive loads cause a phase angle shift between the phase current and phase voltage.

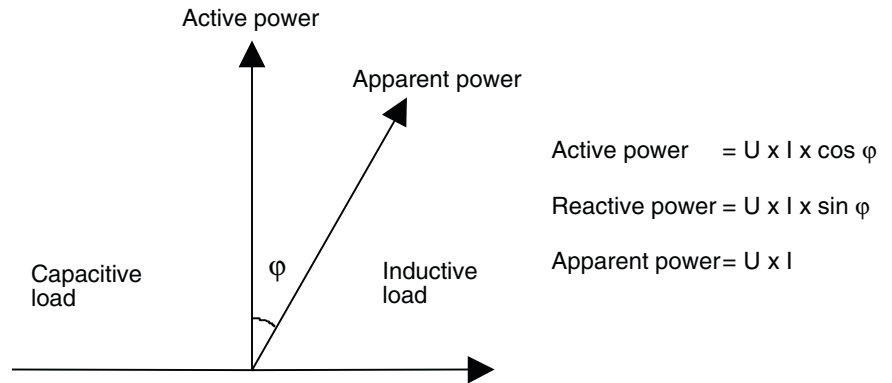

The maximum permitted phase angle shift is often contractually defined by the power supply companies. So that the specified values are not exceeded, power factor correction systems are often installed and the consumption is monitored using reactive energy meters or combination meters.

### 6.1.2 Measurements with current and voltage transformers

So that energy consumption can be measured in installations with current and voltage levels beyond the nominal measuring range of the EIB Delta-Meter, it is necessary to use current and/or voltage transformers. It is important that the secondary current and voltage of the measurement transformers, lie within the permitted measuring ranges of the transformer rated meter. In order to guarantee the required level of accuracy, the selected transformers should have a higher accuracy class than the meter. The current transformers must be connected with the correct polarity ( $K1 \Rightarrow L1$ ,  $k1 \Rightarrow l1$ ).

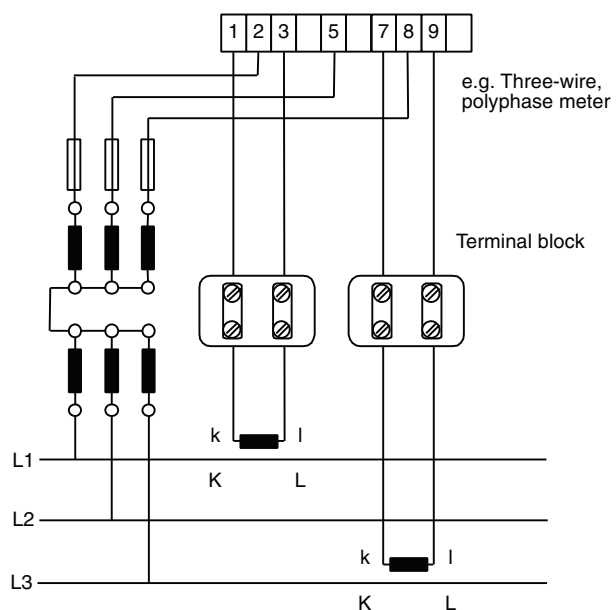

**Note:** The secondary measuring circuits of the transformers must be laid separately to the main power cables to eliminate induced current errors. The terminal block indicated above is not absolutely necessary for the installation but simplifies servicing procedures.

## EIB Delta-Meter Plus Electricity Meters

**Power consumption of the secondary measuring circuits:** If current transformers are to be connected to an EIB Delta-Meter, it is necessary to consider the power consumption of the entire secondary measuring circuits when selecting the current transformers, so that accurate measured values are achieved. The nominal power of the current transformer ( $S_{sec}$ ) must be selected according to the power loss of the connected meter and the power loss of the secondary measuring circuits.

The following applies:

$$S_{sec} \geq S_{cable} + S_{meter} \quad S = \text{Apparent power (VA)}$$

The table of recommended values below represents the power consumption of the cable ( $S_{cable}$ ) as a function of the cable length and cross section.

Secondary current A	Cross section mm <sup>2</sup>	Power consumption of cable						
		Cable lengths (outgoing and return cable)						
		1 m	2 m	5 m	10 m	20 m	50 m	100 m
1 A	1.0	0.04	0.07	0.18	0.36	0.71	1.78	3.57
1 A	2.5	0.01	0.03	0.07	0.14	0.29	0.72	1.43
1 A	4.0	–	–	–	0.09	0.18	0.45	0.89
5 A	2.5	0.36	0.71	1.78	3.57	7.10	17.8	–
5 A	4.0	0.22	0.45	1.12	2.24	4.50	11.2	22.4
5 A	6.0	0.15	0.30	0.74	1.49	3.00	7.40	14.9

**Energy summation:** If the energy of several loads is to be measured using a single electricity meter connected to more than one current transformer per phase, the individual lines that are assigned to the current transformer must be operated in parallel. All current transformers used must have the same transformer ratio. The total of all the currents may not exceed 6 A. In the example shown (three-wire network), the meter measures the total energy consumption of cable 1 and cable 2. The type of load (asymmetrical or symmetrical) is not significant in this case.

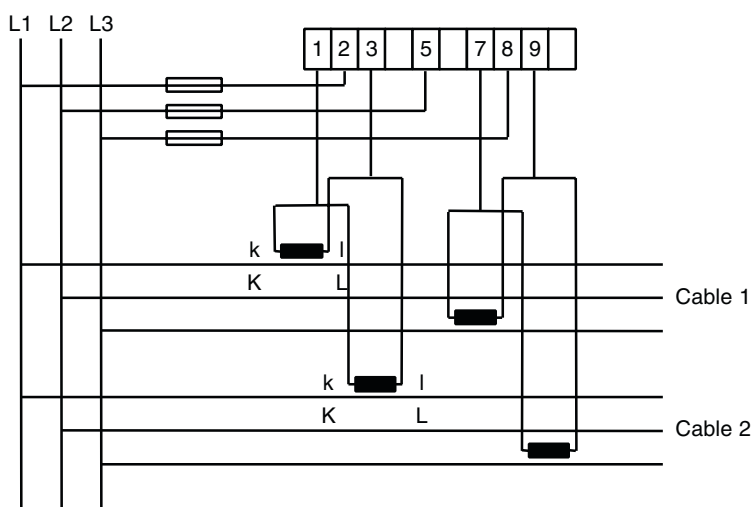

The same application is possible in a four-wire network. Current transformers must then be operated in L1, L2, L3. The current transformers must be connected with the correct polarity (K1 ⇒ L1, k1 ⇒ I1).

### 6.1.3 Calculation of energy

The energy consumption can be read out from the LCD display of the EIB Delta-Meter and can also be recorded and processed remotely using the EIB communication interface.

In the case of direct connected EIB Delta-Meters, the energy in the LCD display is identical to the energy that has been consumed. If current and/or voltage transformers have been used, the displayed consumption value must be multiplied by the transformer ratio (CT x VT) in order to determine the actual, primary energy consumption.

The light-emitting diodes next to the meter readout and the LCD display symbols [A] and [R], flash at a rate [Z<sub>k</sub>] of:

Direct connected meter 1000 Imp/kWh (kvarh)

Transformer rated meter 5000 Imp/kWh (kvarh)

The equations in the following example can be used in order to calculate the LED/LCD flash rate at the given power.

#### Three-wire polyphase network with current and voltage transformers:

Type of current transformer: 250/5 A/A

Type of voltage transformer: 600/100 V/V

Secondary current (I): 3 A

Secondary voltage (U): 100 V

Power factor (cos φ): 0.9

Meter constant (LED, LCD) (Z<sub>k</sub>): 5000 Imp/kWh

#### Transformer ratio of voltage transformer (VT):

$$VT = \frac{\text{Primary voltage (U}_p\text{)}}{\text{Secondary voltage (U}_s\text{)}} = \frac{600 \text{ V}}{100 \text{ V}} = 6$$

#### Transformer ratio of current transformer (CT):

$$CT = \frac{\text{Primary current (I}_p\text{)}}{\text{Secondary current (I}_s\text{)}} = \frac{250 \text{ A}}{5 \text{ A}} = 50$$

#### Secondary power (P<sub>s</sub>):

$$P_s = \frac{\sqrt{3} \cdot U \cdot I \cdot \cos \varphi}{1000} = \frac{\sqrt{3} \cdot 100 \text{ V} \cdot 3 \text{ A} \cdot 0.9}{1000} = 0.47 \text{ kW}$$

#### Primary power (P<sub>p</sub>):

$$P_p = P_s \cdot CT \cdot VT = 0.47 \text{ kWh} \cdot 50 \cdot 6 = 141 \text{ kW}$$

#### LED/LCD flash frequency (B<sub>f</sub>):

$$B_f = \frac{P_s \cdot Z_k}{3600} = \frac{0.47 \text{ kW} \cdot 5000 \text{ Imp/kWh}}{3600} = 0.65 \text{ Hz}$$

#### LED/LCD flash period (B<sub>p</sub>):

$$B_p = \frac{1}{B_f} = \frac{1}{0.65 \text{ Hz}} = 1.53 \text{ s}$$

When connected correctly, the LED and the LCD display symbol [A] should flash approx. every 1.5 seconds in the above example.

**6.2 Error codes**

Once the installation self-test has been carried out, possible errors are displayed in **'Menu mode' [3 Error]** as installation error codes. The displayed error codes can have different meanings for two-wire, single-phase meters or three-wire and four-wire, polyphase meters.

- Err 100:** Phase voltage L1 is not available  
**Note:** Phase voltage L1 is not connected
- Err 101:** **Three-wire, polyphase meter:** Not used. (The absence of phase voltage L2 is also reported by phase angle error code 119).  
**Four-wire, polyphase meter:** Phase voltage L2 is not available.  
**Note:** Phase voltage L2 is not connected.
- Err 102:** Phase voltage L3 is not available.  
**Note:** Phase voltage L3 is not connected.
- Err 103:** **Two-wire, single-phase meter:** Voltage L1 lies above the given maximum value.  
**Three-wire, polyphase meter:** Voltage between phase L1 and L2 lies above the given maximum value.  
**Four-wire, polyphase meter:** Phase voltage L1 lies above the given maximum value.  
**Note:** Meter has the wrong nominal voltage value for this application. Wrong voltage transformer.  
**Risk of damage. Disconnect the voltage immediately.**
- Err 104:** **Two-wire, single-phase meter:** Voltage L1 lies below the given minimum value.  
**Three-wire, polyphase meter:** Voltage between phase L1 and L2 lies below the given minimum value.  
**Four-wire, polyphase meter:** Phase voltage L1 lies below the given minimum value.  
**Note:** Meter has the wrong nominal voltage value for this application. Wrong voltage transformer.
- Err 105:** Phase current L1 lies above the given maximum value.  
**Note:** Meter has the wrong nominal current for this application. Wrong current transformer.
- Err 107:** **Four-wire, polyphase meter:** Phase voltage L2 lies above the given maximum value.  
**Note:** Meter has the wrong nominal voltage value for this application. Wrong voltage transformer.  
**Risk of damage. Disconnect the voltage immediately.**
- Err 108:** **Four-wire, polyphase meter:** Phase voltage L2 lies below the given minimum value.  
**Note:** Meter has the wrong nominal voltage value for this application. Wrong voltage transformer.
- Err 109:** Phase current L2 lies above the given maximum value.  
**Note:** Meter has the wrong nominal current value for this application. Wrong current transformer.
- Err 111:** **Three-wire, polyphase meter:** Voltage between phase L1 and L2 lies above the given maximum value.  
**Four-wire, polyphase meter:** Phase voltage L3 lies above the given maximum value.  
**Note:** Meter has the wrong nominal voltage value for this application. Wrong voltage transformer.  
**Risk of damage. Disconnect the voltage immediately.**
- Err 112:** **Three-wire, polyphase meter:** Voltage between phase L1 and L2 lies below the given minimum value.  
**Four-wire, polyphase meter:** Phase voltage L3 lies below the given minimum value.  
**Note:** Meter has the wrong nominal voltage value for this application. Wrong voltage transformer.

- Err 113:** Phase current L3 lies above the given maximum value.  
**Note:** Meter has the wrong nominal current for this application.  
Wrong current transformer.
- Err 115:** System frequency lies above the given maximum value (> 65 Hz).
- Err 116:** System frequency lies below the given minimum value (< 45 Hz).
- Err 118:** **Two-wire, single-phase meter:** Phase angle between the voltage and current does not lie within the normal range.  
**Three-wire, polyphase meter:** Phase angles between phase voltages L1, L2 and phase current L1 do not lie within the normal range.  
**Four-wire, polyphase meter:** Phase angles between phase voltage L1 and phase current L1 do not lie within the normal range.  
**Note:** Polarity of the load current connection has been reversed.  
Direction of current flow in the current transformer is incorrect.  
Phase voltages have been wrongly connected.
- Err 119:** **Four-wire, polyphase meter:** Phase angle between phase voltages L1 and L2 does not lie within the normal range.  
**Note:** Phase voltages have been wrongly connected.
- Err 120:** **Four-wire, polyphase meter:** Phase angles between phase voltage L1 and phase current L2 does not lie within the normal range.  
**Note:** Polarity of the load current connection has been reversed.  
Direction of current flow in the current transformer is incorrect.  
Phase voltages have been wrongly connected.
- Err 121:** **Three-wire, polyphase meter:** Phase angles between phase voltages L1 and L3 as well as L2 and L3 do not lie within the normal range.  
**Four-wire, polyphase meter:** Phase angle between phase voltage L1 and L3 does not lie within the normal range.  
**Note:** Phase voltages have been wrongly connected.
- Err 122:** **Three-wire, polyphase meter:** Phase angles between phase voltages L1, L2 and phase current L3 do not lie within the normal range.  
**Four-wire, polyphase meter:** Phase angle between phase voltage L1 and phase current L3 does not lie within the normal range.  
**Note:** Polarity of the load current connection has been reversed.  
Direction of current flow in the current transformer is incorrect.  
Phase voltages have been wrongly connected.
- Err 123:** **Two-wire, single-phase meter:** Negative active power.  
**Four-wire, polyphase meter:** Negative active power in phase L1.  
**Note:** Polarity of the load current connection has been reversed.  
Direction of current flow in the current transformer is incorrect.  
Phase voltages have been wrongly connected.
- Err 124:** **Four-wire, polyphase meter:** Negative active power in phase L2.  
**Note:** Polarity of the load current connection has been reversed.  
Direction of current flow in the current transformer is incorrect.  
Phase voltages have been wrongly connected.
- Err 125:** **Four-wire, polyphase meter:** Negative active power in phase L1.  
**Note:** Polarity of the load current connection has been reversed.  
Direction of current flow in the current transformer is incorrect.  
Phase voltages have been wrongly connected.
- Err 126:** Total active power is negative.  
**Note:** Polarity of the load current connection has been reversed.  
Direction of current flow in the current transformer is incorrect.  
Phase voltages have been wrongly connected.
- Err 127, 128, 129:** Internal error. Installation self-test could not be carried out.  
**Note:** Repeat the test. If the error message remains, contact your dealer.

**Error codes that have not been mentioned:**

Internal errors. Contact your dealer.

**6.3 Standard EIB Delta-Meters Plus with network monitoring function**

**Selection table:**

**Transformer rated meters for /1 A and /5 A current transformers**

Voltage V	Current A	Class	Ordering info.		bbn 73 92696 EAN	Unit weight kg	Pack unit (Pc.)
			Short code	Product code			

**Active energy meters**

1 x 57..288	5	1	<b>DZ+ 2105 W E</b>	2CMA139121R1000	<b>39121 4</b>	0.4	1
3 x 100..500	5	1	<b>DZ+ 3105 W E</b>	2CMA139045R1000	<b>39045 3</b>	0.4	1
3 x 57..288/100..500	5	1	<b>DZ+ 4105 W E</b>	2CMA139046R1000	<b>39046 0</b>	0.4	1

**Combination meters (active and reactive power)**

3 x 57..288/100..500	5	1	<b>DZ+ 4105 K E</b>	2CMA139056R1000	<b>39056 9</b>	0.4	1
----------------------	---	---	---------------------	-----------------	----------------	-----	---

**Tariff meters (4 tariffs)**

3 x 57..288/100..500	5	1	<b>DZ+ 4105 WT E</b>	2CMA139048R1000	<b>39048 4</b>	0.4	1
----------------------	---	---	----------------------	-----------------	----------------	-----	---

**Note:** Both the PTB-approved and standard EIB transformer rated meters have an adjustable transformation ratio. This ratio only influences the displayed values for the LCD display. Consumption and measured values are always transferred on the EIB as secondary values. If these values should be indicated on a display or visualisation terminal, they must be multiplied by the transformation ratio.

**Selection table: Direct connected meters**

Voltage V	Current A	Class	Ordering info.		bbn 73 92696 EAN	Unit weight kg	Pack unit (Pc.)
			Short code	Product code			

**Active energy meters**

1 x 57..288	5(80)	2	<b>DZ+ 2280 W E</b>	2CMA139051R1000	<b>39051 4</b>	0.4	1
3 x 100..500	5(80)	2	<b>DZ+ 3280 W E</b>	2CMA139052R1000	<b>39052 1</b>	0.4	1
3 x 57..288/100..500	5(80)	1	<b>DZ+ 4180 W E</b>	2CMA139049R1000	<b>39049 1</b>	0.4	1
3 x 57..288/100..500	5(80)	2	<b>DZ+ 4280 W E</b>	2CMA139053R1000	<b>39053 8</b>	0.4	1

**Combination meters (active and reactive power)**

3 x 57..288/100..500	5(80)	2	<b>DZ+ 4280 K E</b>	2CMA139127R1000	<b>39127 6</b>	0.4	1
----------------------	-------	---	---------------------	-----------------	----------------	-----	---

**Tariff meters (4 tariffs)**

3 x 57..288/100..500	5(80)	2	<b>DZ+ 4280 WT E</b>	2CMA139055R1000	<b>39055 2</b>	0.4	1
----------------------	-------	---	----------------------	-----------------	----------------	-----	---

## EIB Delta-Meter Plus Electricity Meters

### 6.4 PTB-approved EIB Delta-Meters Plus with official authentication<sup>①</sup> and mains monitoring function

#### Selection table:

##### Transformer rated meters for /1 A and /5 A current transformers

Voltage V	Current A	Class	Ordering info.		bbn 73 92696 EAN	Unit weight kg	Pack unit (Pc.)
			Short code	Product code			

##### Active energy meters

1 x 57..288	5	1	<b>DZ+ 2105 W PE</b>	2CMA139044R1000	<b>39044 6</b>	0.4	1
3 x 100..500	5	1	<b>DZ+ 3105 W PE</b>	2CMA139122R1000	<b>39122 1</b>	0.4	1
3 x 57..288/100..500	5	1	<b>DZ+ 4105 W PE</b>	2CMA139047R1000	<b>39047 7</b>	0.4	1

##### Combination meters (active and reactive power)

3 x 57..288/100..500	5	1	<b>DZ+ 4105 K PE</b>	2CMA139057R1000	<b>39057 6</b>	0.4	1
----------------------	---	---	----------------------	-----------------	----------------	-----	---

##### Tariff meters (4 tariffs)

3 x 57..288/100..500	5	1	<b>DZ+ 4105 WT PE</b>	2CMA139123R1000	<b>39123 8</b>	0.4	1
----------------------	---	---	-----------------------	-----------------	----------------	-----	---

**Note:** Both the PTB-approved and standard EIB transformer rated meters have an adjustable transformation ratio. This ratio only influences the displayed values for the LCD display. Consumption and measured values are always transferred on the EIB as secondary values. If these values should be indicated on a display or visualisation terminal, they must be multiplied by the transformation ratio.

#### Selection table: Direct connected meters

Voltage V	Current A	Class	Ordering info.		bbn 73 92696 EAN	Unit weight kg	Pack unit (Pc.)
			Short code	Product code			

##### Active energy meters

1 x 57..288	5(80)	2	<b>DZ+ 2280 W PE</b>	2CMA139124R1000	<b>39124 5</b>	0.4	1
3 x 100..500	5(80)	2	<b>DZ+ 3280 W PE</b>	2CMA139125R1000	<b>39125 2</b>	0.4	1
3 x 57..288/100..500	5(80)	1	<b>DZ+ 4180 W PE</b>	2CMA139050R1000	<b>39050 7</b>	0.4	1
3 x 57..288/100..500	5(80)	2	<b>DZ+ 4280 W PE</b>	2CMA139054R1000	<b>39054 5</b>	0.4	1

##### Combination meters (active and reactive power)

3 x 57..288/100..500	5(80)	2	<b>DZ+ 4280 K PE</b>	2CMA139128R1000	<b>39128 3</b>	0.4	1
----------------------	-------	---	----------------------	-----------------	----------------	-----	---

##### Tariff meters (4 tariffs)

3 x 57..288/100..500	5(80)	2	<b>DZ+ 4280 WT PE</b>	2CMA139126R1000	<b>39126 9</b>	0.4	1
----------------------	-------	---	-----------------------	-----------------	----------------	-----	---

<sup>①</sup> The ABB i-bus® EIB connection is not able to be certified.

#### Accessories

Panel mounting kit for Delta-Meter			<b>DZ-FTB</b>	2CMA132635R1000	<b>32635 3</b>	0.21	1
------------------------------------	--	--	---------------	-----------------	----------------	------	---



The information in this leaflet is subject to change without further notice.

Pub. No. 2CDC 512 038 D0201

---

Your EIB-Partner