

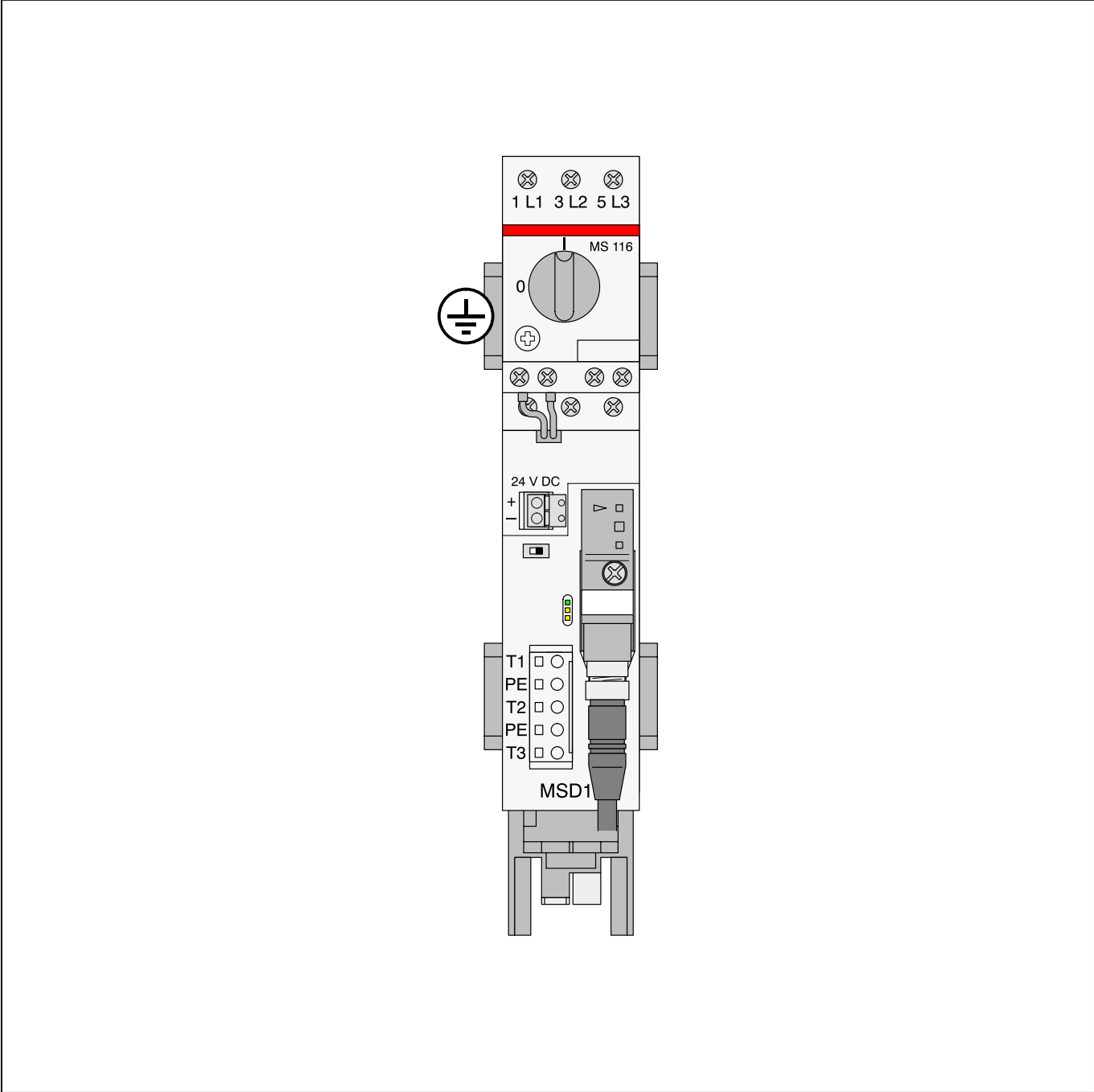

V6

Motor Starter Direct
MSD11-FBP



MSD11-FBP Motor Starter Direct

1 motor, 1 direction of rotation, 0.1...12 A
 Technical description



V 6

MSD11-FBP: Motor branch connection

1 motor, 1 direction of rotation

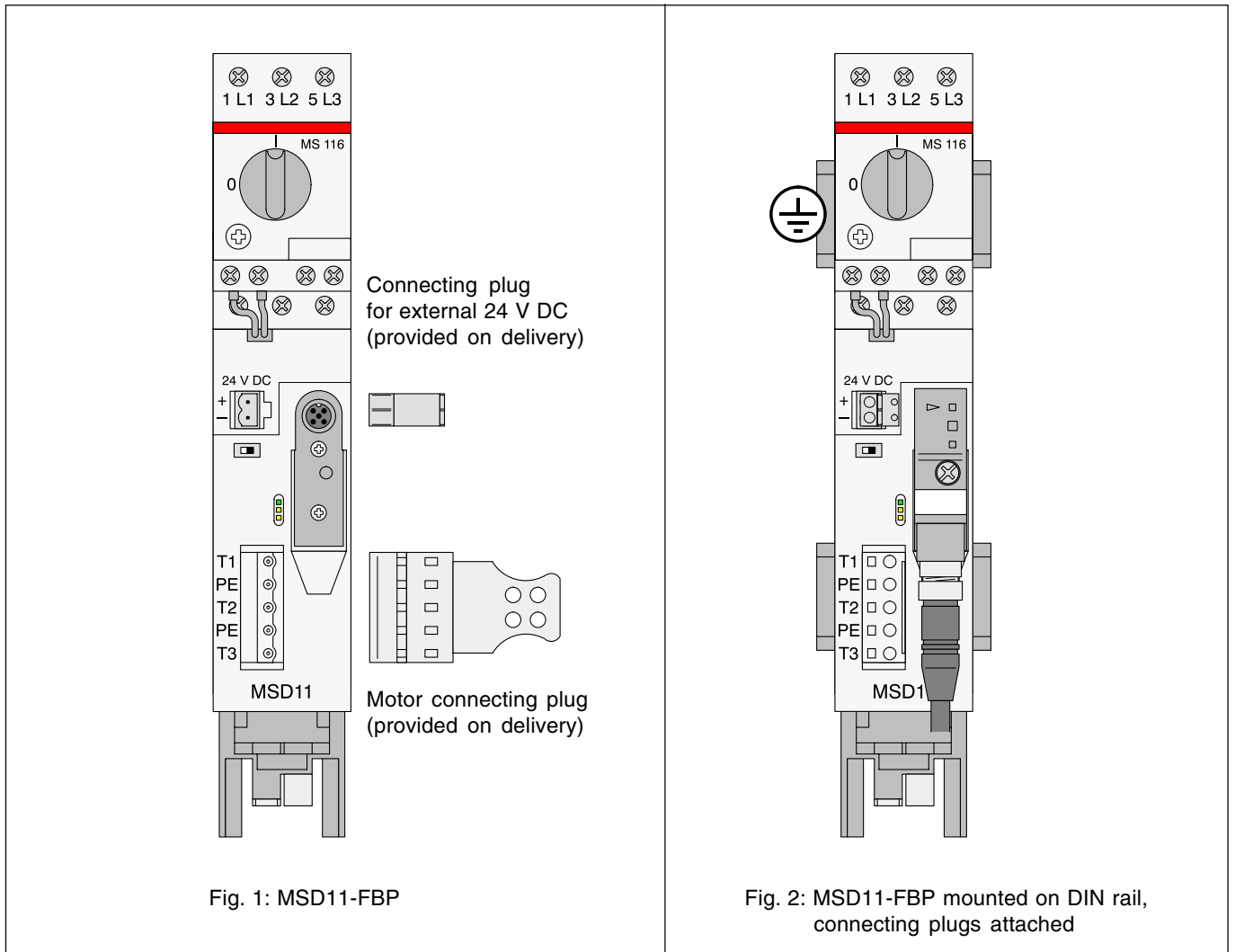

Contents

Page

Purpose	4
Terminals, indicators and operating elements on the front plate	4
Mounting and removal	5
Three-phase current connection	6
Application example	7
Usage of MSD11-FBP with field bus	8
Technical data	9
Ordering data	10
Mechanical dimensions	11



MSD11-FBP Motor Starter Direct

1 motor, 1 direction of rotation, 0.1...12 A

Technical description

V 6

Purpose

The direct motor starter MSD11-FBP is a line tap for switching and protecting three-phase motors and their supply lines with nominal currents of up to 12 A. The unit is assembled on a mounting plate and contains

- the ABB motor protecting switch MS 116,
- an ABB contactor of the series B 7,
- a front plate with indicators and operating elements
- a field bus-neutral interface.

The control signal for switching the connected motor is received via the inserted field bus plug. The field bus plug type depends on the desired bus system.

The unit is mounted on one or two DIN rails (for improved vibration resistance). The power supply for this combination of units is provided via the field bus. The integrated contactor (coil) as well as the electronic circuitry can be supplied via the field bus plug or by an external power supply.

Terminals, indicators and operating elements on the front plate

Fig. 3 shows the MSD11-FBP with its terminals, indicators and operating elements.

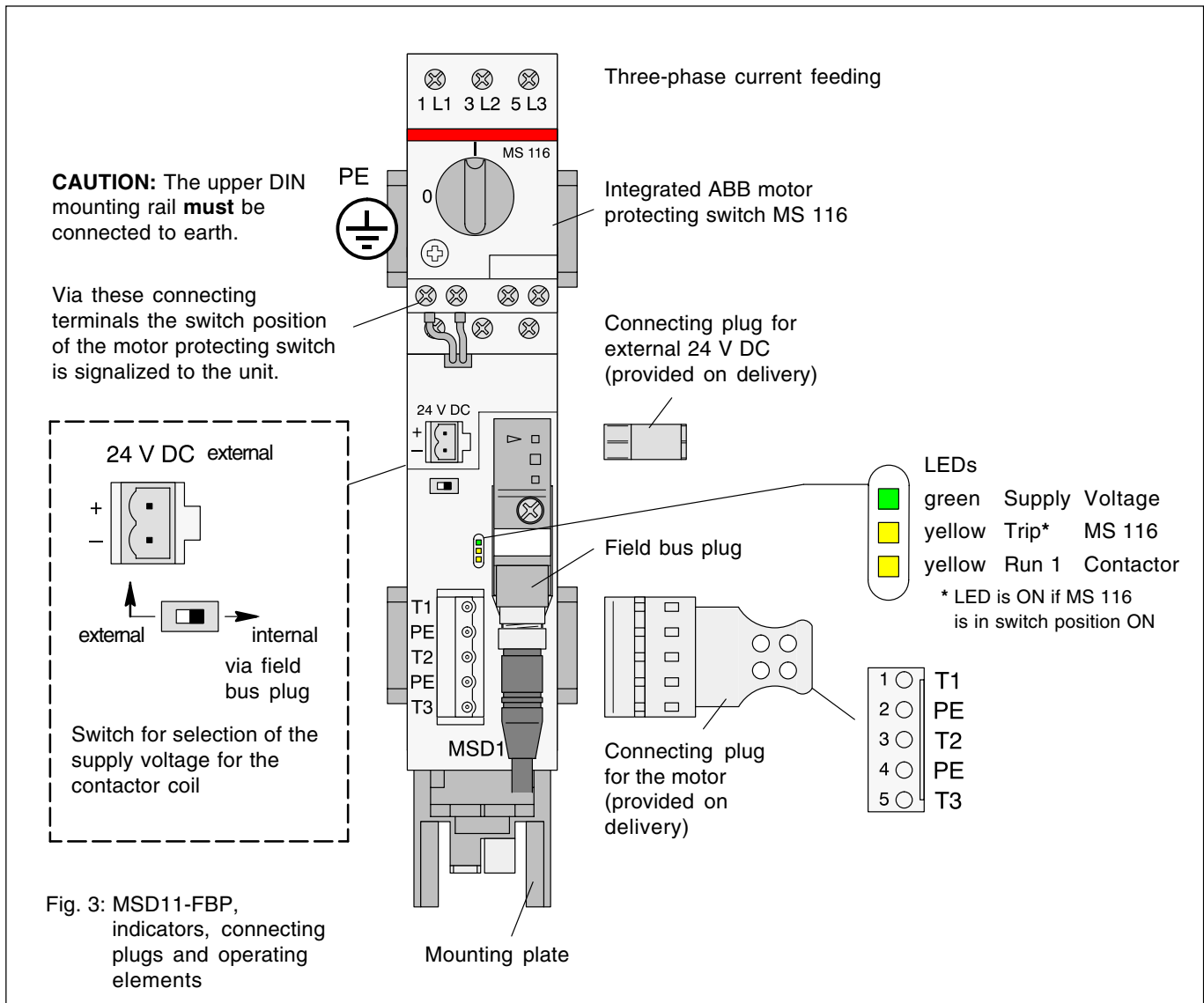



Mounting and removal

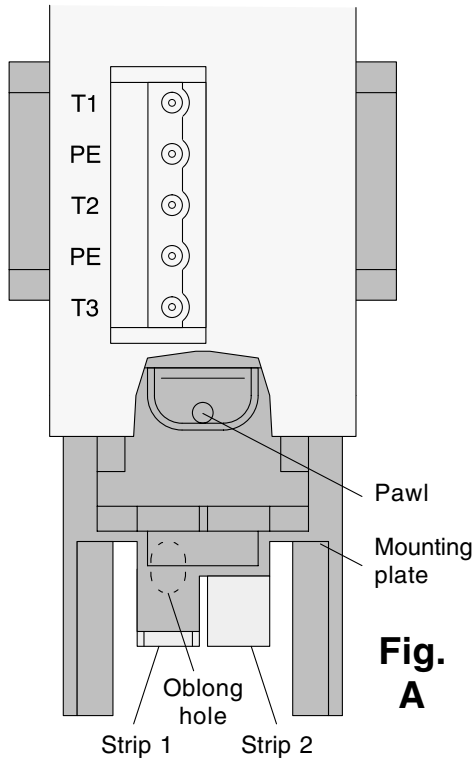

Fig. A

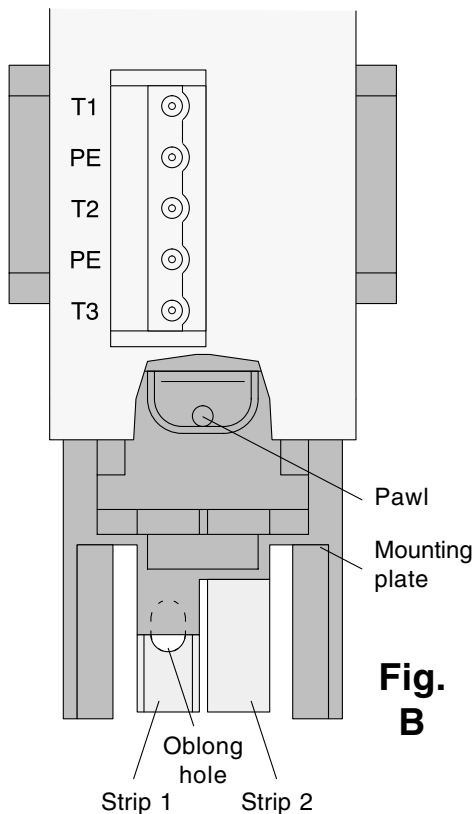

Fig. B

Mounting

1. Use a screw driver to pull the oblong hole strip 1 downwards until it audibly locks. Refer to Fig. A (before) and Fig. B (afterwards).
2. Insert the unit on the upper mounting rail, so that the earthing connection is established.
3. Press the unit onto the lower mounting rail and hold it in this position.
4. Press strip 2 to the rear. Strip 1 is unlocked and the unit is now fixed on the mounting rail.

Removal

1. Use a screw driver to pull the oblong hole strip 1 downwards until it audibly locks. Refer to Fig. A (before) and Fig. B (afterwards).
2. Lift the unit a little bit off from the lower mounting rail.
3. Take the unit off from the upper mounting rail and remove it.
4. Press strip 2 to the rear. Strip 1 is unlocked again (refer to Fig. A).

Connecting or disconnecting the three-phase current feeding

The front part of the unit can be unlatched and slipped downwards on the mounting plate (refer to Fig. C). This way, the three-phase current feeding can be easier removed (e.g. from a conductor rail).

For this purpose, the pawl (refer to Fig. B) must be pressed to the rear.

When sliding the front part of the unit back to the top position, the pawl locks again (audibly).

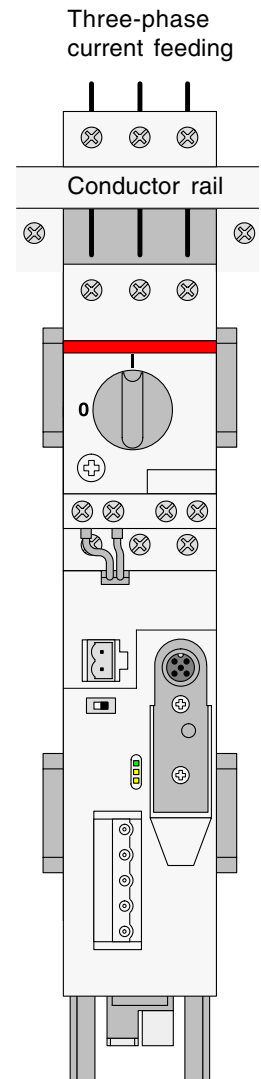

Fig. C

Fig. 4: Mounting and removal of the MSD11-FBP



MSD11-FBP Motor Starter Direct

1 motor, 1 direction of rotation, 0.1...12 A

Technical description

V 6

Three-phase current connection

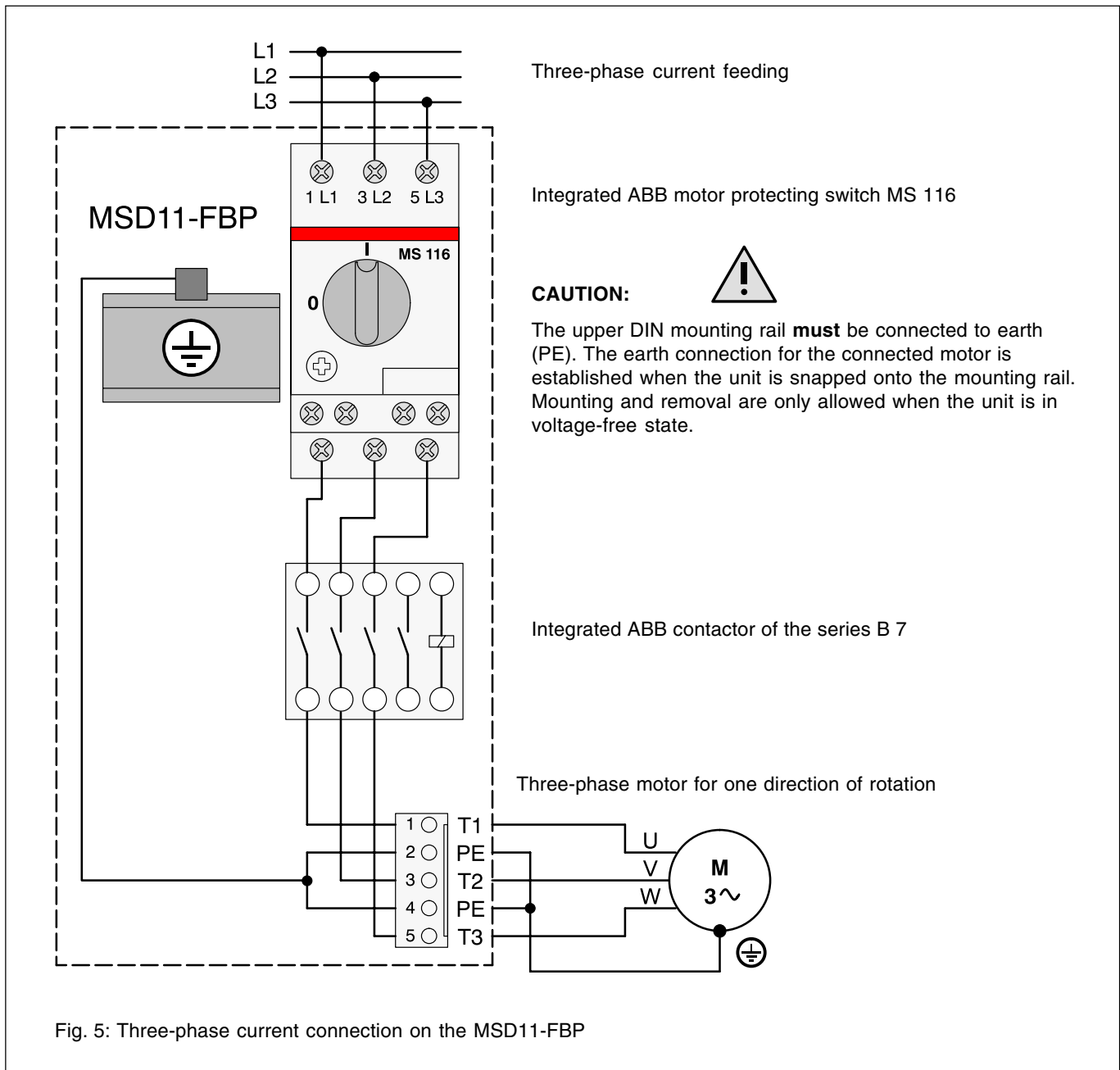

MSD11-FBP Motor Starter Direct

1 motor, 1 direction of rotation, 0.1...12 A
 Technical description



V 6

Application example

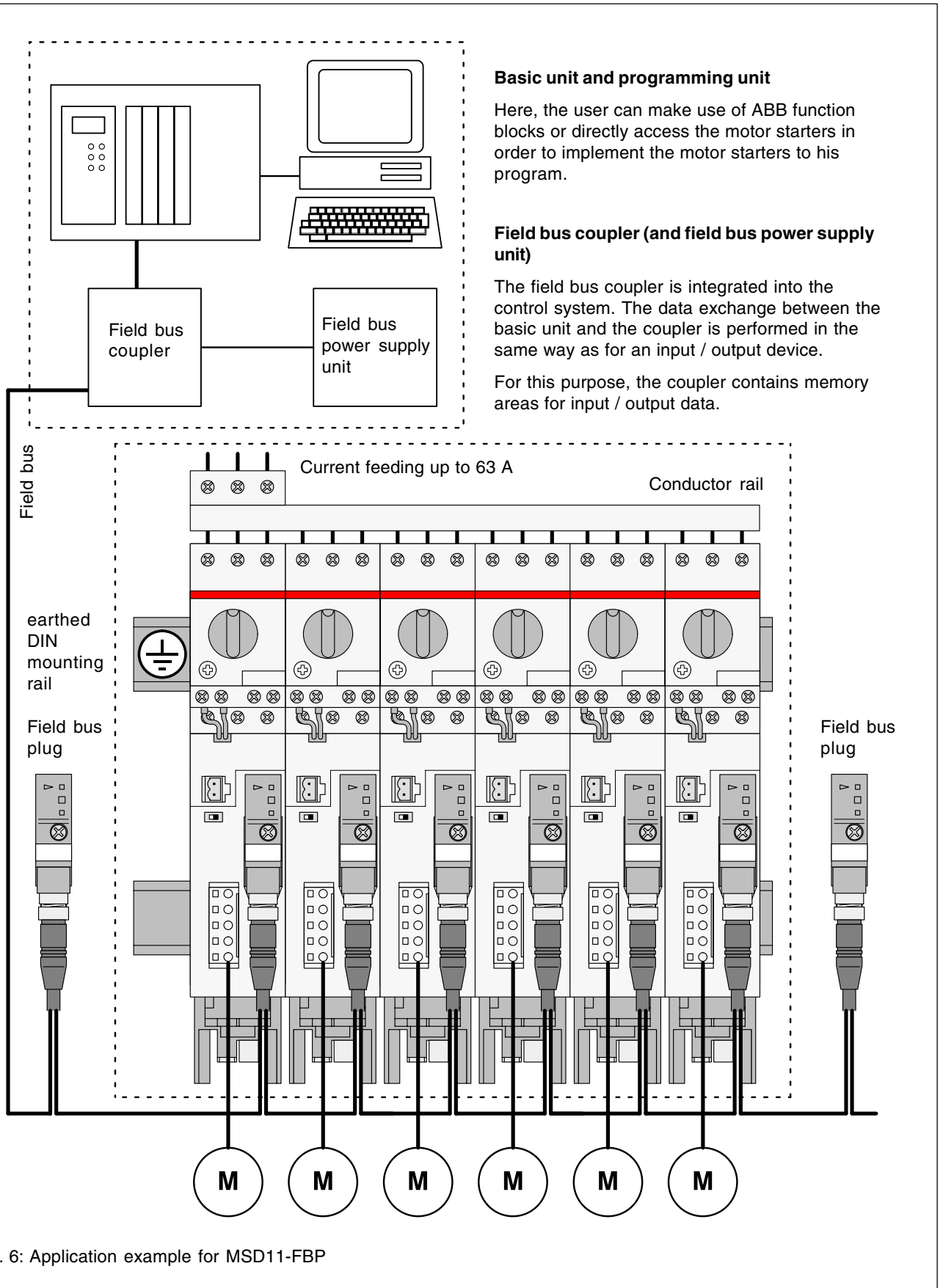

Fig. 6: Application example for MSD11-FBP



MSD11-FBP Motor Starter Direct

1 motor, 1 direction of rotation, 0.1...12 A

Technical description

V 6

Usage of MSD11-FBP with field bus

Behavior, features, addressing and restrictions for the MSD11-FBP when used on the AS-Interface bus:
Refer to the description of the AS-Interface bus.

Behavior, features, addressing and restrictions for the MSD11-FBP when used on the DeviceNet bus:
Sorry, we are still working on it.

Behavior, features, addressing and restrictions for the MSD11-FBP when used on the PROFIBUS:
Sorry, we are still working on it.

MSD11-FBP Motor Starter Direct

1 motor, 1 direction of rotation, 0.1...12 A

Technical description

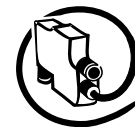

V 6

Technical data

General data

Nominal operating voltage	400 V AC, 50 Hz and 60 Hz, three-phase current
max. motor current AC-3	12 A
Mounting	on one or two DIN rails (spacing 125 mm, for increased vibration resistance)
Optional mounting and current feeding	Wöhner conductor rail system, D-Rittal
Motor connection	
plug connector on front side	5-pole plug provided on delivery
conductor cross section	max. 2.5 mm ²
Earthing connection (PE) for upper mounting rail	min. 10 mm ² , carries the earthing of the motor
Degree of protection	IP20
Ambient temperature	
storage	-25...+80 °C
operation	0...+55 °C
Dimensions	refer to Fig. 7
width	45 mm
height	260 mm
depth	138 mm (incl. field bus plug and connecting plug for motor)
Total power dissipation of the unit	9 W
Weight	0.65 kg
Bus address setting	depending on the field bus type (address switch, field bus plug, PLC software)
Diagnostics	3 LEDs on the front plate
green LED	24 V supply voltage present
yellow LED	MS 116 ON
yellow LED	contactor ON
Intended approvals	CE, UL, CSA, GL, BV, LRS
Motor protection	by integrated ABB motor protecting switch MS 116 (overload, short circuit)
Integrated contactor	ABB series B 7
Supply of contactor (coil) and electronics	selectable (by switch) from field bus plug or external 24 V DC
Current consumption	140 mA at 24 V DC
Connection for external 24 V DC	
plug-in conn. on front side	2-pole plug provided on delivery
conductor cross section	max. 1.5 mm ²

Data for the integrated motor protecting switch MS 116 (in extracts)

Three-phase current feeding	via screw terminals M 3.5, Pozidrive No. 2
conductor cross sections	single- or multiple wire 2 x 1...4 mm ² , fine-wire with wire-end ferrules 2 x 0,75...2,5 mm ² , usage of conductor rails possible
Ranges for operating current setting	0.1 ... 12 A divided in 11 ranges, see also "Ordering data"
Switching frequency (for motor starting)	up to 15 starts per hour or up to 60 starts per hour at 40 % duty ratio at a starting time of 1 s
Short-circuit strength at 400 V AC	
range 0.1...10 A	short-circuit proof up to a prospective short-circuit current of 50 kA
range 8...12 A	short-circuit breaking capacity up to 25 kA, fuse on line side required, gL max. 80 A



MSD11-FBP Motor Starter Direct

1 motor, 1 direction of rotation, 0.1...12 A
Technical description

V 6

Data for the integrated B7 contactor (in extracts)

Contact rating	max. 12 A, AC-3, 400 V AC
Contact lifetime at 12 A, AC-3	700 000 switching cycles

Field bus plug connection

Mounting	plug connection, fastening with supplied screw
Suitable ABB field bus plug types	AS-Interface-P yes AS-Interface-D yes DeviceNet yes PROFIBUS DP yes
Parameter assignment via field bus	none

Ordering data for MSD11-FBP

Scope of delivery	MSD11-FBP incl. connecting plugs for motor and external 24 V DC supply
-------------------	--

Ordering numbers	
range 0.10...0.16 A	1SAJ 3100 00 R0001
range 0.16...0.25 A	1SAJ 3100 00 R0002
range 0.25...0.40 A	1SAJ 3100 00 R0003
range 0.40...0.63 A	1SAJ 3100 00 R0004
range 0.63...1.0 A	1SAJ 3100 00 R0005
range 1.0...1.6 A	1SAJ 3100 00 R0006
range 1.6...2.5 A	1SAJ 3100 00 R0007
range 2.5...4.0 A	1SAJ 3100 00 R0008
range 4.0...6.3 A	1SAJ 3100 00 R0009
range 6.3...10 A	1SAJ 3100 00 R0010
range 8...12 A	1SAJ 3100 00 R0011

MSD11-FBP Motor Starter Direct

1 motor, 1 direction of rotation, 0.1...12 A
Technical description



V 6

Mechanical dimensions

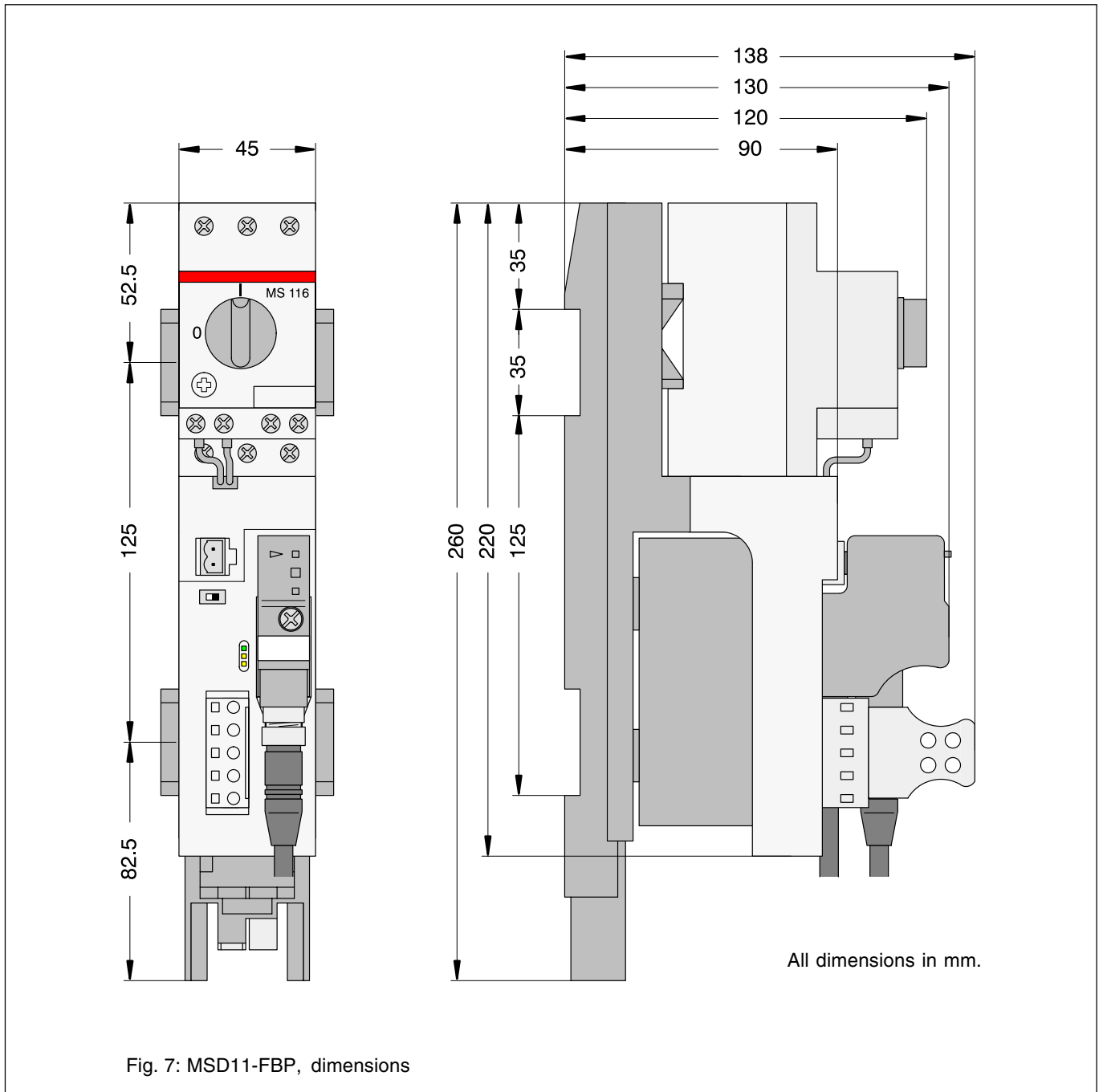



MSD11-FBP Motor Starter Direct

1 motor, 1 direction of rotation, 0.1...12 A

Technical description

V 6



ABB STOTZ-KONTAKT GmbH

Eppelheimer Straße 82 Postfach 101680
69123 Heidelberg 69006 Heidelberg
Germany Germany

Telephone +49 6221 701-0
Telefax +49 6221 701-240
E-Mail desst.help@de.abb.com
Internet <http://www.abb.de/stotz-kontakt>