

TWS-1

EG5738
GHV0215738R 0001



Istruzioni per l'uso
dell'interruttore crepuscolare



Operating Instructions for
twilight switch



Bedienungsanleitung
Lichtsteuergerät



Notice d'utilisation de
l'interrupteur



Instrucciones de empleo del
interruptor crepuscular



Instruções de serviço para o
interruptor crepuscular

System proM

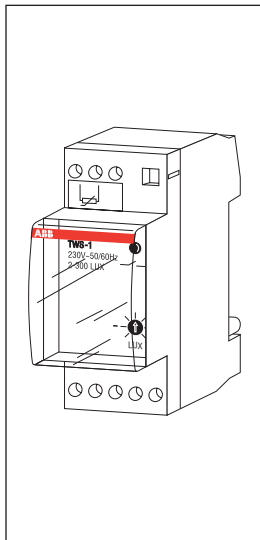

49971

ABB



Descrizione generale

L'interruttore crepuscolare consente l'accensione / spegnimento di apparecchi illuminanti, considerando il livello di luminosità preimpostato sull'apparecchio (TWS-1) con il livello di luminosità esterno rilevato dal sensore (LS-1), quando quest'ultimo scende al di sotto di quello preimpostato, l'apparecchio TWS-1 dà il consenso alla chiusura del circuito.

Istruzioni di montaggio

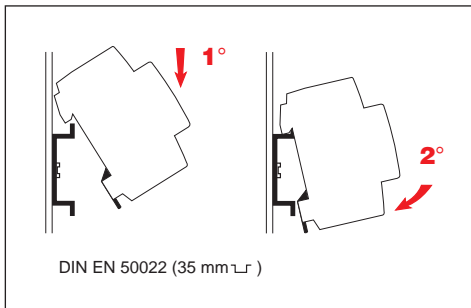

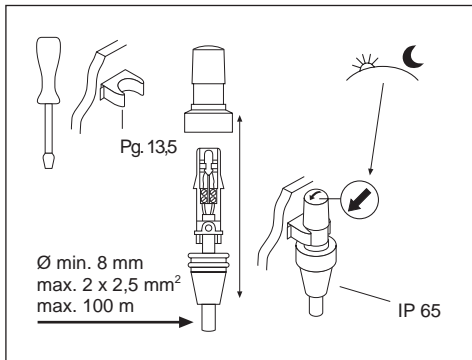

Schema di collegamento

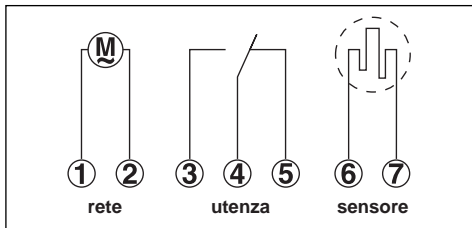

Principio di funzionamento

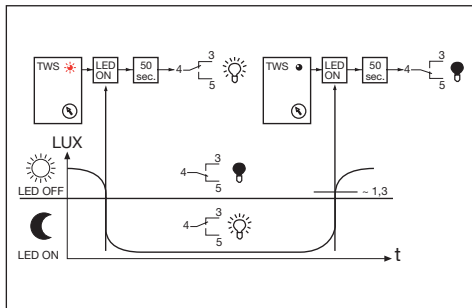

Caratteristiche tecniche

Tensione nominale Un	V	230 c.a.
Portata del contatto c.a.	A	16 (carico resistivo $\cos\varphi= 1$) 2,5 (carico induttivo $\cos\varphi= 0,6$)
	W	1000 (lampade a fluorescenza rifasate)
Frequenza	Hz	50/60
Portata del contatto c.c.	mA	800 (a 24 V) 300 (a 60 V) 150 (a 220 V)
Natura del contatto		In commutazione
Campo di regolazione	Lux	da 2 a 300
Regolazione		Elettronica
Isteresi	%	1,3 (del valore impostato)
Ritardo di commutazione	s.	50 (all'accensione) 50 (allo spegnimento)
Temp. di funzionamento crepuscolare	°C	-20 / +55
Temp. di funzionamento sensore	°C	-30 / +70
Grado di protezione del crepuscolare	IP	20
Grado di protezione del sensore	IP	65
Lunghezza max cavo tra crepuscolare e sensore	m	100
Potenza dissipata	W	5
Numero di moduli	N°	2

• DIMENSIONI D'INGOMBRO

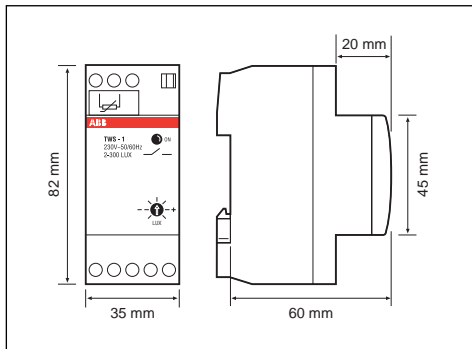

General description

The twilight switch allows lights to be automatically switched on and off according to the lighting level. The external lighting level detected by the sensor (LS-1) is compared with the lighting level previously set on the device (TWS-1): the circuit closes when the latter is higher.

Mounting Instructions

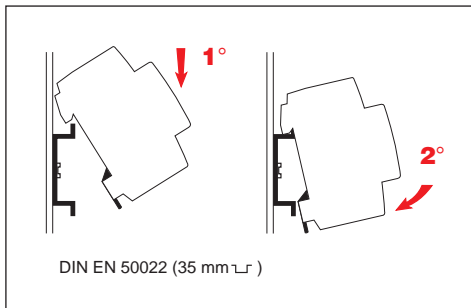

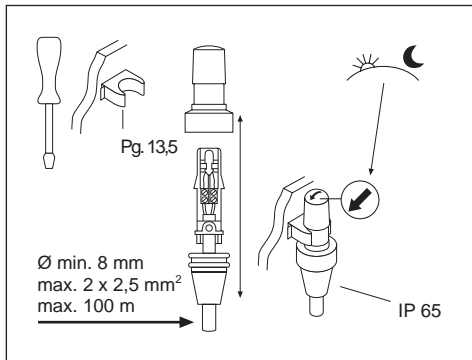

Connection diagram

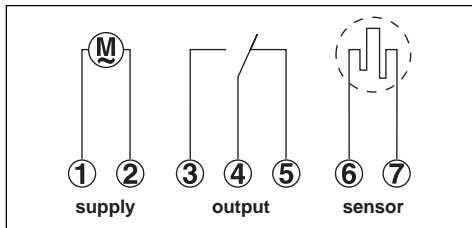

Principle of operation

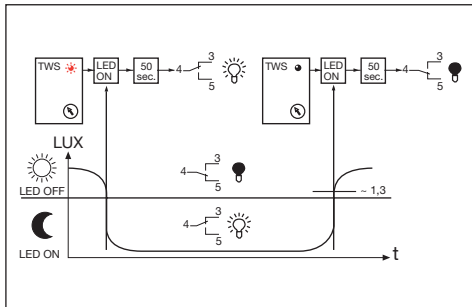

Technical specifications

Nominal voltage Un	V	230 a.c.
AC contact capacity	A	16 (resistive load $\cos\varphi = 1$) 2.5 (inductive load $\cos\varphi = 0.6$)
	W	1000 (power factor corrected fluorescent lamps)
Frequency	Hz	50 / 60
DC contact capacity	mA	800 (at 24V)
		300 (at 60V)
		150 (at 220V)
Contact type		Switched
Range of adjustment	Lux	2 to 300
Control		Electronic
Hysteresis	%	1,3 (of setting)
Switching delay	s.	50 (switch-on)
		50 (switch-off)
Twilight switch operating temperature	°C	-20 / +55
Sensor operating temperature	°C	-30 / +70
Twilight switch protection degree	IP	20
Sensor	IP	65
Maximum cable length from twilight switch to sensor	m	100
Power consumption	W	5
Number of modules	N°	2

• OVERALL DIMENSIONS

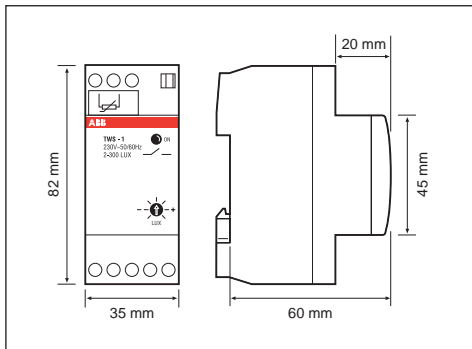

Allgemeine Beschreibung

Mit dem Lichtsteuergerät können Beleuchtungen ein- und ausgeschaltet werden, unter Berücksichtigung der auf dem Gerät (TWS-1) voreingestellten Helligkeitsstufe mit der externen Helligkeitsstufe, die vom Sensor (LS-1) gemessen wird. Übersteigt diese den voreingestellten Wert, gibt das Gerät TWS-1 den Befehl zum Schließen des Schaltkreises.

Bauanleitungen

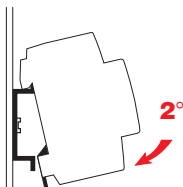
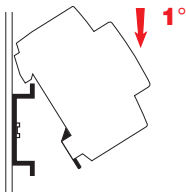

DIN EN 50022 (35 mm \perp)

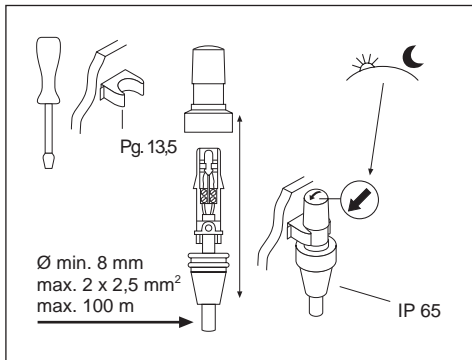

Anschlußplan

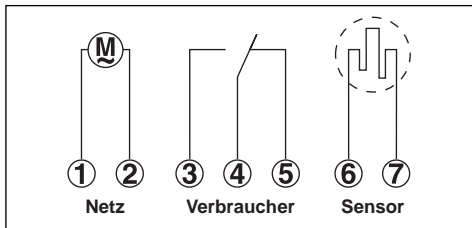

Funktionsprinzip

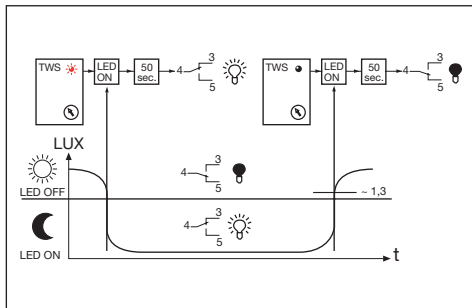

Technische Daten

Bemessungsspannung	V	230 AC
Schaltleistung AC	A	16 (ohmsche Last $\cos\varphi = 1$) 2,5 (Induktive Last $\cos\varphi = 0,6$)
	W	1000 (Leuchtstofflampen mit Blindleistungskompensation)
Frequenz	Hz	50/60
Schaltleistung DC	mA	800 (bei 24 V DC) 300 (bei 60 V DC) 150 (bei 220 V DC)
Schaltkontakt		1 Wechsler
Helligkeitsbereich	Lux	2 - 300
Regelung		elektronisch
Hysterese	%	1,3 (des eingestellten Wertes)
Ein-Aus Schaltverzögerung	s	50 (beim Einschalten) 50 (beim Ausschalten)
Betriebstemperatur		
- Lichtsteuergerät	°C	-20...+55
- Sensor	°C	-30...+70
Schutzart		
- Lichtsteuergerät	IP	20
- Sensor	IP	65
Max. Kabellänge zwischen Lichtsteuergerät und Sensor	m	100
Verlustleistung	W	5
Modulzahl		2 (35 mm)

• ABMESSUNGEN

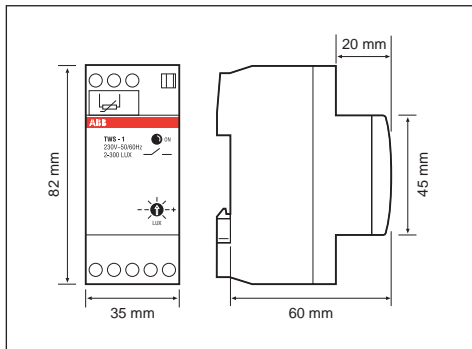

Description générale

Cet interrupteur permet d'allumer et d'éteindre des appareils d'éclairage en comparant le niveau de luminosité programmé sur l'appareil (TWS-1) avec celui de la luminosité externe détecté par la cellule (LS-1). Lorsque ce dernier dépasse le niveau programmé, le TWS-1 autorise la fermeture du circuit..

Instructions de montage

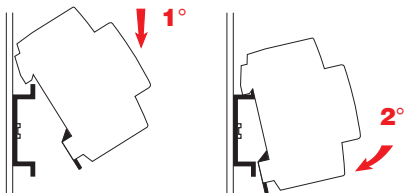

DIN EN 50022 (35 mm \sqcup)



Schéma de raccordement



Principe de fonctionnement

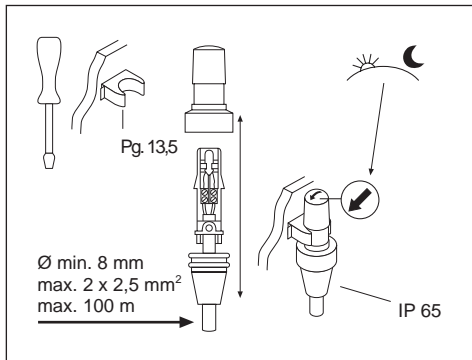
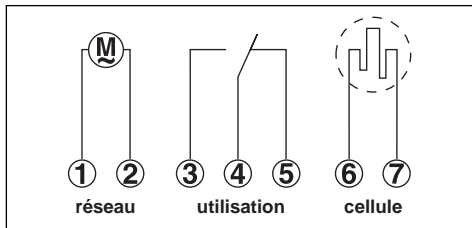
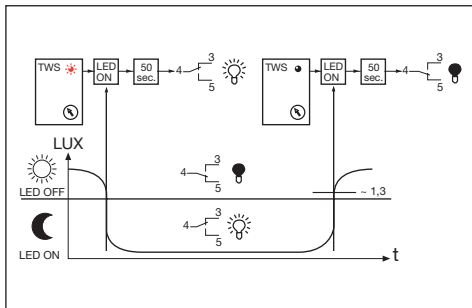

Caractéristiques techniques

Tension nominal	V	230 c.a.
Portée du contact c.a.	A	16 (charge résistive $\cos\varphi= 1$) 2,5 (charge inductive $\cos\varphi= 0,6$) W 1000 (fluorescent compense)
Fréquence	Hz	50 / 60
Portée du contact c.c.	mA	800 (à 24 V) 300 (à 60V) 150 (à 220V)
Nature du contact		contact inverseur
Plage de réglage	Lux	de 2 à 300
Réglage		Electronique
Hystérésis	%	1,3 (de la valeur programmée)
Retard de commutation	sec.	50 (à l'allumage) 50 (à l'extinction)
Temp. de fonctionnement de l'interrupteur	°C	-20 / +55
Temp. de fonctionnement de la cellule	°C	-30 / +70
Degré de protection de l'interrupteur	IP	20
Degré de protection de la cellule	IP	65
Longueur max. du câble entre l'interrupteur et la cellule	m	100
Puissance dissipée	W	5
Nombre de modules	N°	2

• DIMENSIONS HORS TOUT

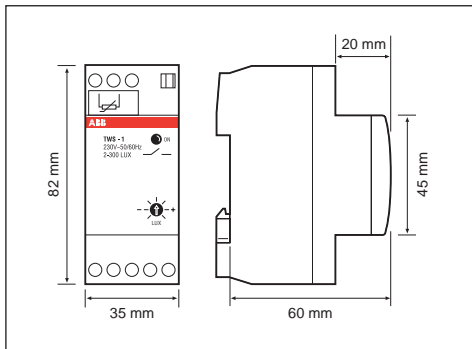

Descripción general

El interruptor crepuscular permite el encendido / apagado de aparatos de iluminación, considerando el nivel de luminosidad preprogramado en el aparato (TWS-1) con respecto al nivel de luminosidad externo detectado por el sensor (LS-1); cuando el nivel de luminosidad exterior es superior al preprogramado en el aparato, se produce la conmutación del contacto de salida.

Instrucciones de montaje

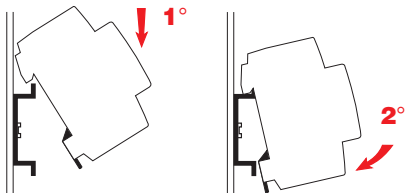

DIN EN 50022 (35 mm \lrcorner)

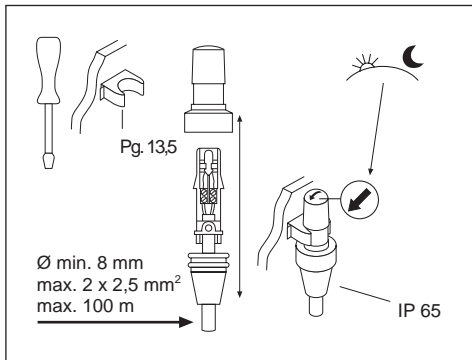

Esquema de conexión

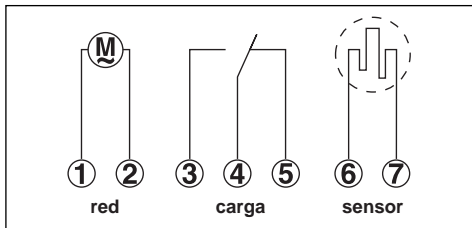

Principio de funcionamiento

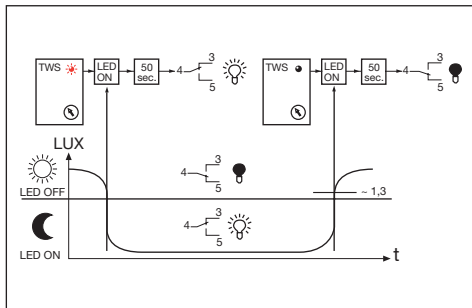

Características técnicas

Tensión nominal Un	V	230 c.a.
Capacidad del contacto en c.a.	A	16 (carga resistiva $\cos\varphi=1$) 2,5 (carga inductiva $\cos\varphi=0,6$)
	W	1000 (lámparas de fluorescencia de fase corregida)
Frecuencia	Hz	50/60
Capacidad del contacto en c.c.	mA	800 (a 24 V) 300 (a 60 V) 150 (a 220 V)
Tipo de contacto		conmutado
Campo de regulación	Lux	de 2 a 300
Regulación		Electrónica
Histéresis	%	1,3 (del valor programado)
Retardo de conmutación	seg.	50 (al encendido) 50 (al apagado)
Temp. de funcionamiento del interruptor crepuscular	°C	-20 / +55
Temp. de funcionamiento sensor	°C	-30 / +70
Grado de protección del interruptor crepuscular	IP	20
Grado de protección del sensor	IP	65
Longitud máxima cable entre del interruptor crepuscular	m	100
Potencia consumida	W	5
Número de módulos		2

• DIMENSIONES MÁXIMAS EXTERNAS

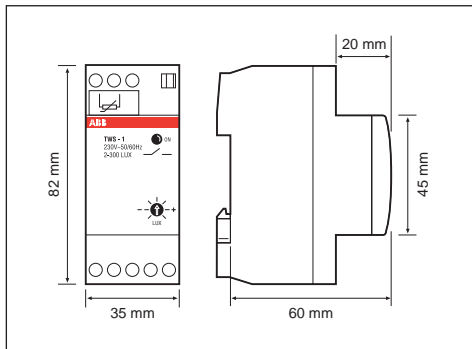



Descrição geral

O Interruptor Crepuscular permite ligar / desligar circuitos de iluminação levando em consideração o nível de luminosidade previamente programado no aparelho (TWS-1). Quando este nível ultrapassar o nível de luminosidade exterior detectado pelo sensor (LS-1), o Interruptor Crepuscular dará ordem para o fecho do circuito.

Instruções para montagem

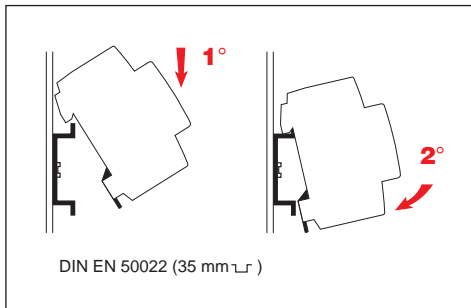

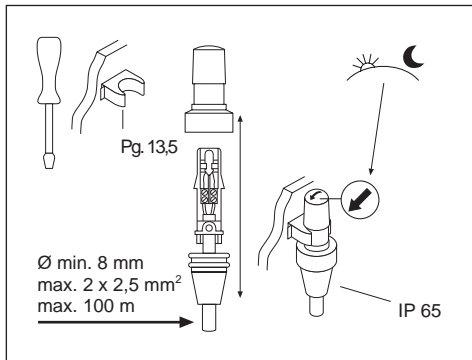

Esquema de ligação

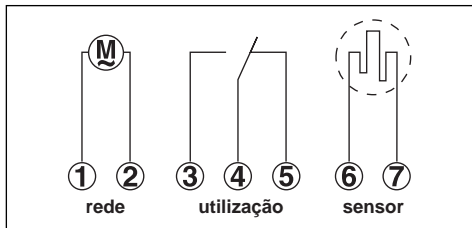

Princípio de funcionamento

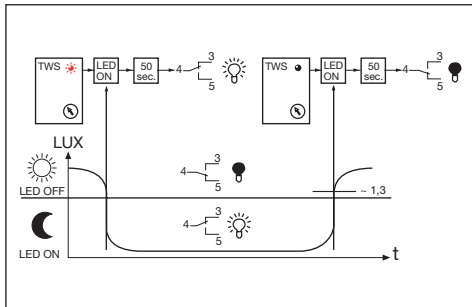

Características técnicas

Tensão nominal Un.	V	230 C.A.
Capacidade de contacto C.A.	A.	16 (carga de resistência $\cos\varphi= 1$) 2,5 (carga indutiva $\cos\varphi= 0,6$) W. 1000 (lâmpadas com fluorescência refasada)
Frequência	Hz.	50 / 60
Capacidade de contacto C.C.	mA	800 (com 24 V.) 300 (com 60 V.) 150 (com 220 V.).
Natureza do contacto		Em comutação
Faixa de regulação	Lux	Desde 2 até 300
Regulação		Electrónica
Histerese	%	1,3 (do valor programado)
Atraso na comutação	Seg.	50 (para acender) 50 (para apagar).
Temp. de funcionamento crepuscular	°C	-20 / +55
Temp. de funcionamento sensor	°C	-30 / +70
Grau de protecção crepuscular	IP	20
Grau de protecção sensor	IP	65
Cumprimento máx. do cabo entre crepuscular e sensor	m.	100
Potência dissipada	W.	5
Número de módulos	N.º	2

• DIMENSÕES MÁXIMAS

