

Contents

R 421.2	Store with LED	4/2
R 422.2	Store	4/3
R 422.3	Step chain, 3 stages	4/4
R 425.4	Latching store with LED	4/5
R 426.1	Latching store, 3 functions	4/6
R 427.1	Fast memory with LED	4/7
R 428.1	Dynamic memory with LED	4/8

Store with LED R 421.2

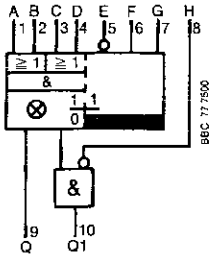

Description

The store R 421.2 consists of a statically operating bistable trigger stage and series connected logical functions. The outputs Q and Q 1 are brought out on the setting side.

With a set store, the outputs carry a 1-signal and the LED is illuminated. With a cleared store the outputs carry a 0-signal.

For setting, a 1-signal must appear at the inputs A or B and at the same time at C or D and E. For clearing, an 0-signal must be applied to E or a 1-signal to F or G.

If setting and clearing conditions are fulfilled simultaneously, the store will reset to the cleared state (predominantly clearing). Without input signals, the store will reset to cleared state when the supply voltage is applied (preferred position).

With a 1-signal on input H the set output Q 1 can be screened. In this case output Q gives a 1-signal.

The outputs Q and Q 1 can switch inductive loads **without** use of free running diodes.

For noise suppression, the store operates with delay.

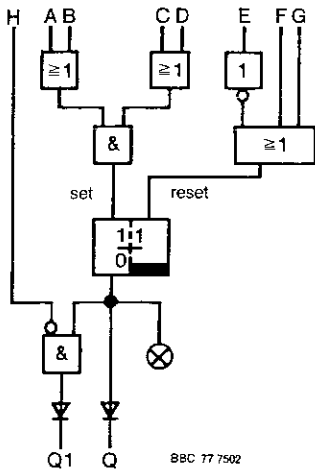

Order code for module:

Order code for circuit symbol transparency:

Order code for application:

Identifying colour:

Mechanical structure:

Weight:

GH R421 0002 R1

GH R700 1901 R59

D NG 3200 80 D

black

single width

approx. 130 g

Technical data

Current consumption, reset store
set store

6 mA

18 mA

Input

1 load

Fan out at Q or Q 1

each

100 loads

Setting delay t_E

typically

8 ms

Resetting delay t_A

typically

2.5 ms

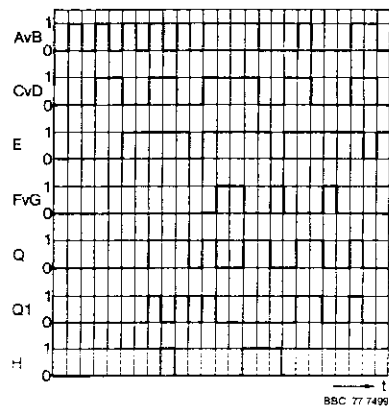

Store R 422.2

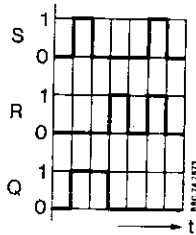
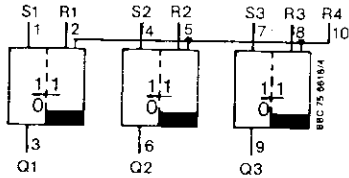

Description

The store R 422.2 consists of three independent bistable trigger stages with an additional common reset input.

Each function has a set input (s-set), a reset input (R-reset) and an output Q which shows a 1-signal when the store is set.

To set a store a 1-signal must be applied to the input S, to reset a 1-signal at the input R. A 1-signal on input R4 clears all three functions.

If a 1-signal appears simultaneously at S and R then at the output Q there appears an 0-signal (predominantly clearing). Without input signals, the store will reset to the cleared state (output Q 0-signal) when the supply voltage is applied (preferred position).

The stores are suitable for operation in conjunction with Logic units for sequence control purposes.

The outputs Q can switch inductive loads **without** use of free running diodes.

For noise suppression the stores operate with delay.

Order code for module:

Order code for circuit symbol transparency:

Order code for application:

Identifying colour:

Mechanical structure:

Weight:

GH R422 0002 R1

GH R700 1901 R72

D NG 3200 80 D

black

single width

approx. 130 g

Technical data

Current consumption, reset stores		10 mA
set stores		35 mA
Input		1 load
Fan out		100 loads
Setting delay t_E	typically	5.5 ms
Resetting delay t_A	typically	3.5 ms

Step chain, 3-stages R 422.3

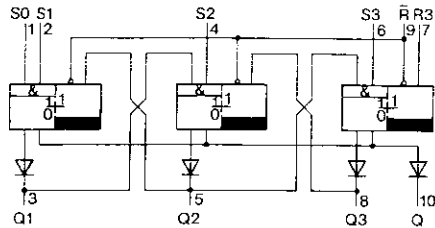

Description

The step chain R 422.3 comprises three statically operating bistable multivibrators which are already interconnected for providing step by step commands. In addition to the step outputs Q1, Q2 and Q3, it also has a collective signal output Q.

The first step is set by a 1 signal at inputs S0, S1, and \bar{R} . Each further step is set when the corresponding input S has a 1 signal and the preceding step is set. After setting the command step, the preceding command step is once again cleared. A 0 signal at the input \bar{R} resets all memories.

The step chain can be expanded to any extent. For this purpose, the inputs and outputs are further interconnected in the same way as in the case of the internal wiring at the clear inputs \bar{R} and collective signal outputs Q are parallel connected.

The outputs can switch inductive loads **without** use of free running diodes.

The memories operate with a delay for noise suppression.

Order code for module:

GH R422 0300 R1

Order code for circuit symbol transparency:

GH R700 1901 R85

Identifying colour:

black

Mechanical structure:

single width

Weight:

approx. 120 g

Technical data

Current consumption
all memories cleared
one memory set

25 mA
28 mA

Input load

1 load

Fan out,

Outputs Q1, Q2, Q3 each:

100 loads less load
at Q

Output Q:

100 loads less load
at Q1 or Q2 or Q3

Memory setting delay

8 ms

Memory clearing delay

2.5 ms

Latching store with LED R 425.4

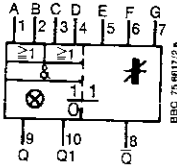

Description

The latching store R 425.4 consists of a statically operating bistable trigger stage with remanence reaction and series connected logical functions. The outputs Q and Q 1 are brought out on the setting side. They therefore show the same signal, but are decoupled via diodes. The output \bar{Q} is brought out of the reset side and thus always carries the opposite signal to Q.

An LED indicated the state of the outputs Q and Q 1. With set store the outputs Q and Q 1 carry 1-signals and the built-in LED is illuminated. Output \bar{Q} gives a 0-signal. With reset store \bar{Q} gives a 1-signal, Q and Q 1 0-signals. In this case the LED remains unilluminated.

The outputs Q, Q 1 and \bar{Q} can switch inductive loads **without** use of free running diodes.

For setting, a 1-signal must be applied at the inputs A or B and at the same time at C or D. For clearing, a 1-signal must be applied to E, F or G.

If the setting and clearing conditions are simultaneously fulfilled, the latching store will reset to the cleared state (predominantly clearing). Without input signals, the latching store will reset when the operation voltage is applied to the state which it held before switching off (remanence reaction).

Example:

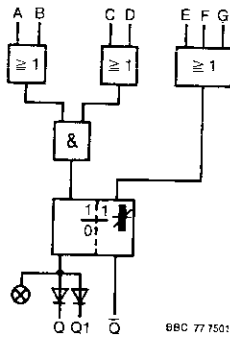

Situation		Disconnection and reconnection of supply voltage	
Reset:			
Output Q and Q 1	0-signal	Q and Q 1	0-signal
Output \bar{Q}	1-signal	\bar{Q}	1-signal
Set:			
Output Q and Q 1	1-signal	Q and Q 1	1-signal
Output \bar{Q}	0-signal	\bar{Q}	0-signal

For noise suppression, the latching store operates with a delay.

Note

Delivered latching stores may show a 1-signal at either output Q and Q 1 or \bar{Q} when the supply voltage is applied to the unit (important when exchanging latching stores in control gear).

Order code for module:
Order code for circuit symbol transparency:
Order code for application:
Identifying colour:
Mechanical structure:
Weight:

GH R425 0004 R1
GH R700 1901 R18
D NG 3200 80 D
black
single width
approx. 130 g

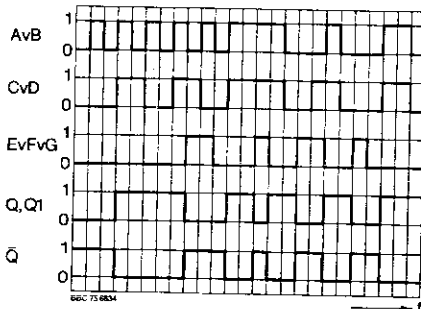

Technical data

Current consumption, reset store	20 mA
set store	40 mA
Input	1 load
Fan out at Q and Q 1 singly or together	100 loads
at \bar{Q}	100 loads
Setting delay t_E	typically 6 ms
Resetting delay t_A	typically 3 ms

Depending on the voltage rise time during reactivation of the supply voltage after interruptions, the following values apply to appearance of the 1 signal at the memory output: Typical supply voltage rise 15 V, tolerance 14 to 16.5 V. In the event of a voltage drop, the 1 signal at the memory output is switched off at voltages between 9.2 V and 12 V.

Latching store, 3 functions R 426.1

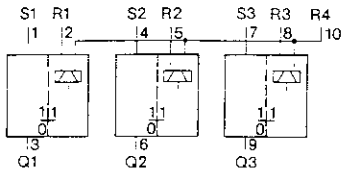

Description

The latching store R 426.1 comprises three mutually independent bistable multivibrators with remanence behavior.

Each function has a set input (S-set), a reset input (R-reset) and an output Q which has a 1 signal when the memory is set.

A 1 signal must be applied to inputs to set a memory and a 1 signal must be applied to input R to reset. A 1 signal at input R4 resets all three memories.

If set and reset conditions are simultaneously fulfilled, the latching store assumes a reset state (reset dominating). When the supply voltage is activated without an input signal having been applied, the latching store assumes the state it had before deactivation (remanence behavior).

The outputs Q can switch inductive loads **without** free running diodes.

The memories operate with a delay for the purpose of noise suppression.

In the event of a slow voltage increase after failure of the supply voltage, the output already assumes the correct signal stage when the supply voltage U_s has small values. However, the signals at the inputs are not processed until the supply voltage has exceeded a value of approximately 15 V.

Note:

When delivered, latching stores may be set or reset when supply voltage is applied (this is important when replacing latching stores in a control).

Order code for module:

GH R426 0100 R1

Order code for circuit symbol transparency:

GH R700 1901 R84

Identifying colour:

black

Mechanical structure:

single width

Weight:

approx. 130 g

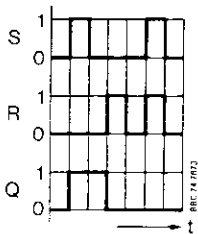

Technical data

Current consumption of the unit

All memories reset

all inputs 0 signal

30 mA

all reset inputs 1 signal

63 mA

All memories set

all inputs 0 signal

51 mA

all set inputs 1 signal

80 mA

Input load

1 load

Fan out

100 loads

Setting delay t_E

typically

8 ms

Resetting delay t_A

typically

4 ms

Fast memory with LED R 427.1

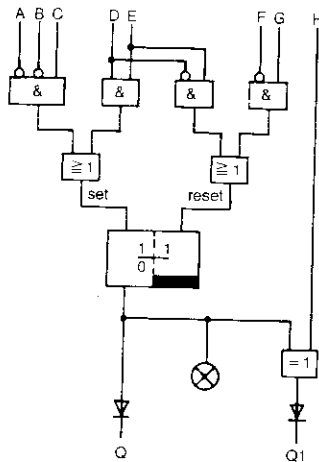
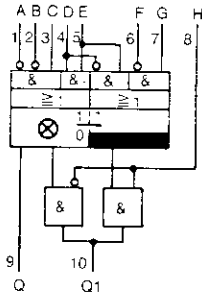

Description

The fast memory R 427.1 consists of a statically operating bistable multivibrator with additional logic functions on the setting and resetting sides.

Within the scope of the counter unit concept R 445, the memory serves as a supplementary unit for implementing various applications such as evaluation of a preselected number or configuration of a counter for arithmetic counting. In addition, the module is also suitable for general applications.

Output Q has a 1 signal when the memory is set. Output Q1 can be controlled via input H. If a 1 signal is applied to H, Q1 is inverted with respect to Q and, in the case of a 0 signal at H, both outputs agree.

A built-in yellow LED lights up when the memory is set.

If setting and resetting conditions are simultaneously fulfilled, the memory assumes the reset state (resetting dominating). Without input signals, the memory assumes reset stage (preferred state) when the supply voltage is connected.

The outputs can switch inductive loads **without** free running diodes.

Order code for module:

Order code for circuit symbol transparency:

Order code for application:

GH R427 0100 R1

GH R700 1901 R76

see modules

R 445.1, R 445.2

and R 445.3

black

single width

approx. 120 g

Identifying colour:

Mechanical structure:

Weight:

Technical data

Current consumption, all inputs 0 signal
memory reset
memory set

15 mA

35 mA

Input loads, per input

1 load

Fan out, per output

100 loads

Setting delay t_E

typically

0.2 ms

Resetting delay t_A

typically

0.2 ms

Maximum cut-off frequency

2 kHz

Dynamic memory with LED R 428.1

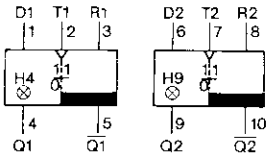

Description

The dynamic memory R 428.1 consists of two mutually independent bistable multivibrators. Each functional unit has a data input (D), a clock input (T), a reset input (R) and a true and inverted output (Q, \bar{Q}).

Input D and R operate statically while input T operates dynamically.

Information pending at the input D is transferred to the memory with the 0-1 edge at the clock input. A 1 signal at input R resets the memory independently of inputs D and T (resetting dominating). Without input signals, the memories have a 0 signal at output Q or a 1 signal at \bar{Q} (preferred state) when the supply voltage is connected. In order to ensure reliable processing, the signal at input D should be applied at least 10 ms before and after arrival of the 0-1 edge at the clock input. During a static 0 or 1 signal at input T, the information at D is ignored.

A built-in yellow LED (H4 and H9) lights up when the memory is set.

All signal inputs operate with a delay for the purpose of noise suppression.

Order code for module:	GH R428 0100 R1
Order code for circuit symbol transparency:	GH R700 1901 R88
Order code for application:	D NG 3154 81 D
Identifying colour:	black
Mechanical structure:	single width
Weight:	approx. 120 g

Technical data

Current consumption, all memories reset	24 mA
all memories set	35 mA
Input load, per input	1 load
Fan out, per output	100 loads
Signal delays (typical values)	
Inputs D1, D2	
0-1 delay	9 ms
1-0 delay	7 ms
Inputs T1, T2, R1, R2,	
0-1 delay	4 ms
1-0 delay	3 ms