



APC03 capacitor bank series

Installation, operation and maintenance instructions

Table of contents

1	Introduction	3
2	Safety instructions	3
3	Upon reception	4
3.1	Lifting and transportation guidelines	4
3.2	Identification tag	4
3.3	Storage	4
3.4	Packing & unpacking	5
4	Products overview and description	6
4.1	APC03 series	6
4.2	APC03 layouts	6
4.3	APC03 internal layouts	7
4.4	Power Factor Controllers	8
4.5	CLMD03 Power module	9
4.6	Ventilation system	9
4.7	Thermal cutoff switch	9
5	Installation	11
5.1	Working conditions: dust, moisture and temperature	11
5.2	Harmonics pollution	11
5.3	Mechanical installation	11
5.3.1	APCL03 capacitor banks	11
5.3.2	APCM03 and APCR03 capacitor banks	12
5.4	Electrical installation	12
5.4.1	Electrical insulation test	12
5.4.2	Electrical connections overview	12
5.4.3	Earth connection	13
5.4.4	Power cables selection	14
5.4.5	APCL03 electrical connections	14
5.4.6	APCM03 and APCR03 electrical connections – Bottom entry	15
5.4.7	APCM03 and APCR03 electrical connections – Top entry	17
5.4.8	Auxiliary power supply	18
5.4.9	Optional auxiliary transformer	18
5.4.10	Current transformer selection	18
5.4.11	Current transformer connection	19
5.4.12	Multi ratio CT and summation transformer	20
5.4.13	ON/OFF release contact	21
5.4.14	Connection of several banks in parallel	21
5.4.15	Circuit breaker connections	22
6	Easy commissioning	24
7	Troubleshooting	27
8	Maintenance	28
9	Dimensions and weights	29
10	Technical Specifications	30
11	Contact us	32

1 Introduction

This manual is intended for qualified electricians that are involved in integrating, installing, operating and/or maintaining an APC03 automatic capacitor bank. They are supposed to know the general electrical wiring practices, electronic components and electrical schematic symbols.

The present manual applies to all APC03 capacitor banks.

2 Safety instructions



These safety instructions are intended for all work on the APC03 series.

Neglecting these instructions can cause physical injuries and death.

All electrical installation and maintenance work on the APC03 automatic capacitor banks should be carried out by qualified electricians.

Do not attempt to work on a powered APC03.



After switching off the power supply to the APC03, always wait at least 5 minutes before working on the unit (i.e. time for the power capacitors to be discharged). Always verify by measurement that capacitors are discharged.

Note: AC capacitor may be charged at higher voltage than network nominal value.

Before manipulating current transformers (CT), make sure that the secondary is short-circuited. Never open the secondary connections of a loaded CT.

You must always wear isolating gloves and eye-protection when working on electrical installations. Also make sure that all local safety regulations are followed.

DANGER:

To ensure safe access, all power supplies (power and auxiliary) of each individual enclosure must be isolated before entry / opening.

This equipment contains capacitors. Check for residual voltage before working inside the equipment.

3 Upon reception

APC03 equipments are delivered in carton box bolded on pallet as per [Figure 2](#) below.

Make sure that the packing is in good conditions.

After removal of the packing (see § 3.4), check visually the exterior and interior of your APC03 capacitor bank.

Any loss or damage should be immediately notified to your ABB representative.

Please also check the presence of following documentation:

- Instruction manual
- Wiring diagram
- RVC or RVT manual

3.1 Lifting and transportation guidelines

Please note that APC03 weighs up to hundreds of kilograms. Care should be taken to ensure that correct handling facilities are used.

During handling and transportation, no shock is allowed.

- In their packing, APC03 equipment must be handled by their pallet.
- When unpacked, APCM03 and APCR03 must be lifted by their lifting lugs. APCM03 and APCR03 can be transported vertically (preferably) or horizontally but without any shock.



Figure 1: lifting lugs

APCL03 must be transported horizontally.

3.2 Identification tag

The APC03 nameplate is located on the front door, at the outside. A second similar nameplate is present inside the cubicle.

The nameplate information should always remain readable to ensure proper identification during the whole life of the APC03 capacitor bank. The bank nameplate includes key data like the type, the nominal voltage and frequency as well as an ABB internal article code and data as per international regulations.

3.3 Storage

The APC03 must be stored indoors, in a dry, dust free, non-corrosive atmosphere and protected from vibrations or shocks.

The storage temperature must be between -20°C (or -4°F) and +60°C (or +140°F).

3.4 Packing & unpacking

APCL, APCM and APCR are delivered in carton boxes.

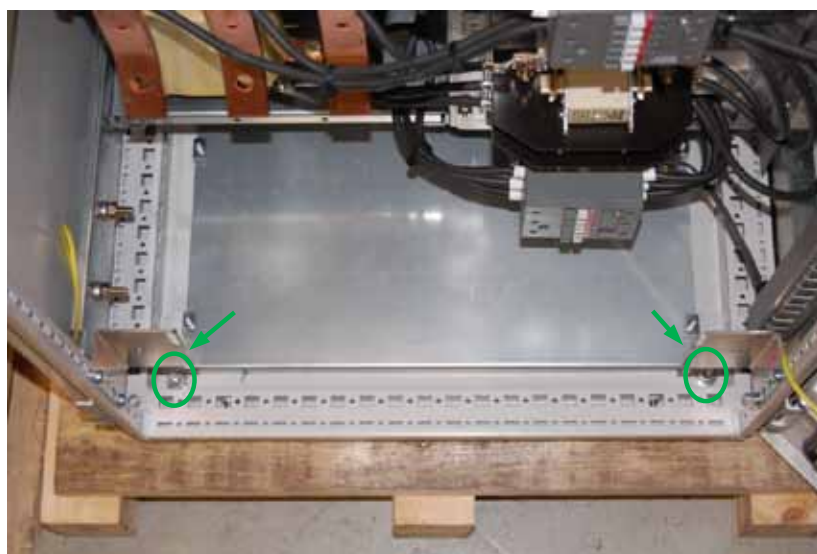

Figure 2: APC03 boxes

	APCM03 & APCR03	APCL03
Box dimensions (including pallet)	720*720*2490 (mm)	870*650*535 (mm)
Packing Weight	16 kg	8 kg
Transportation	Vertical only	Horizontal only

To unpack:

- Remove the nails between the carton box and the pallet and removes the carton
- Unbolt the pallet (four screws). For APCM/R03 remove the back plate to access the back screws.



4 Products overview and description

4.1 APC03 series

There are 3 types of APC03:

- APCL03: wall-mounted cubicles without reactor.
- APCM03: free floor-standing cubicles without reactor.
- APCR03: free floor-standing cubicles with reactors.

All APC03 are available in master execution only, equipped by default with a RVC controller (RVT as an option).

4.2 APC03 layouts

Note: external layouts of APCM03 and APCR03 are identical.



APCM03 and APCR03

APCL03

Figure 3: APC03 layouts

4.3 APC03 internal layouts

Number	APCL03 Description
1	Air outlet
2	Auxiliary transformer (optional)
3	Auxiliary connections
4	Power Factor controller (RVC by default or RVT as an option)
5	UA contactors (Part of CLMD03 Power Module)
6	Main busbar (3-Phase)
7	CLMD03 Power Module
8	Internal protection grid
9	Fan (Air inlet)

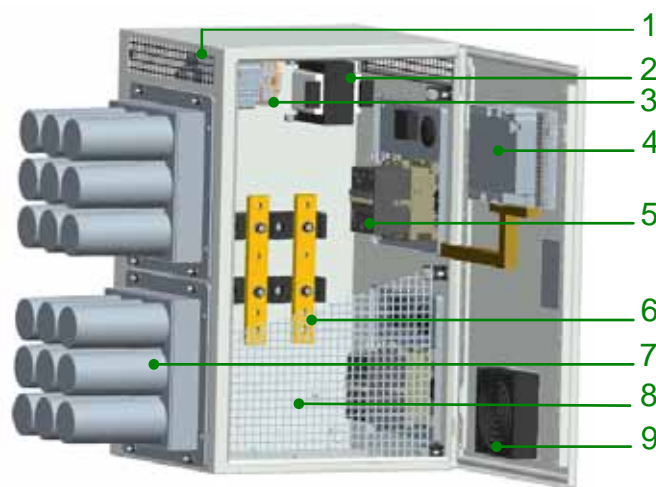

Figure 4: APCL03 internal layout

Number	APCM03 & APCR03 Description
1	Fans (Air outlet)
2	Auxiliary transformer (optional)
3	Power Factor controller (RVC by default or RVT as an option)
4	Auxiliary connectors and fuses
5	CLMD03 Power Module
6	Main busbar (3-Phase)
7	HRC fuses (Part of CLMD03 Power Module)
8	UA contactors (Part of CLMD03 Power Module)
9	Air inlet
10	Reactor
11	Internal protection grid
12	Circuit breaker (optional)

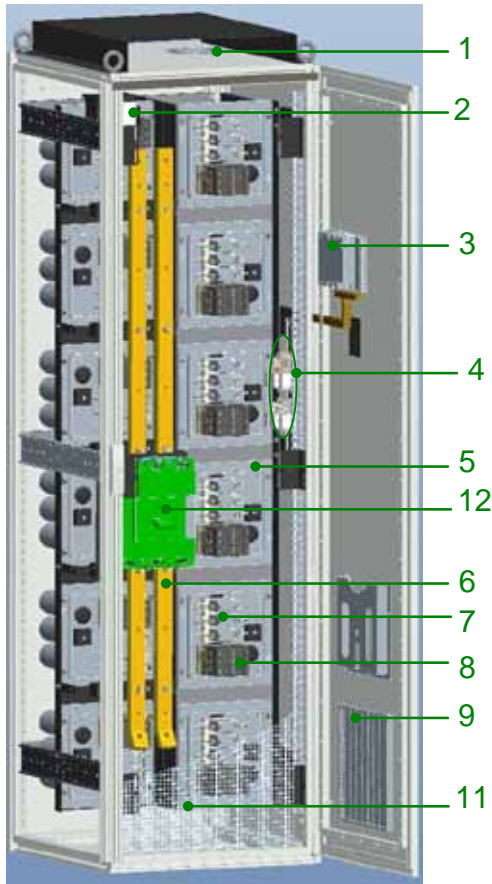

Figure 5: APCM03 internal layout

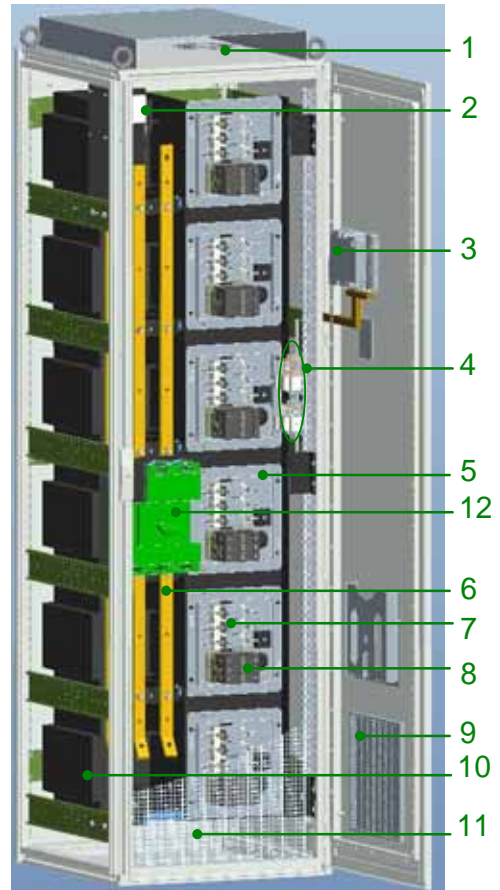

Figure 6: APCR03 internal layout

4.4 Power Factor Controllers

- RVC controller (by default)
- RVT (optional)

Note: the manual of the power factor controller is provided within the capacitor bank.



Figure 7: RVC and RVT Power Factor controllers

4.5 CLMD03 Power module

CLMD03 Power Module is all-in-one pre-wired module, which include capacitor – CLMD03 type, contactor, fuses and discharge resistors.

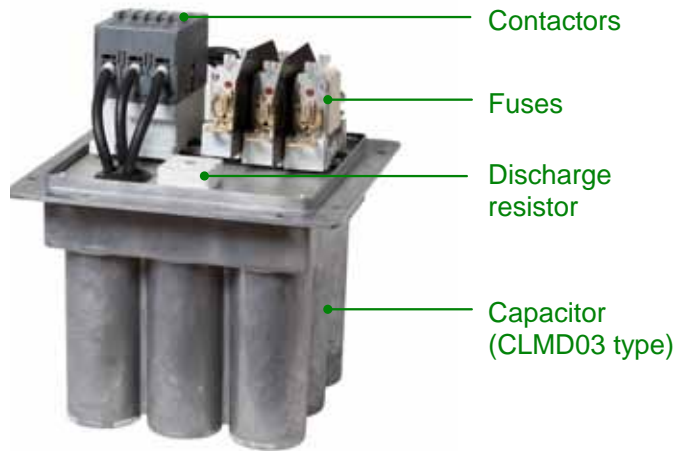

Figure 8: CLMD03 Power module

4.6 Ventilation system

All APC03 capacitor banks are air forced ventilated.

	APCL03	APCM03 & APCR03
Fan quantity	1	2
Fan location	Door	Top

As a matter of protection, the bank does not operate as long as the ventilation circuit is not fed.

Important note: the ventilation system is fed by auxiliary power supply (230V 50Hz or 120V 60Hz) which has to be provided locally except if optional auxiliary transformer is ordered.

4.7 Thermal cutoff switch

Each APC03 cubicle includes a temperature-sensitive switch that cuts the controller power supply (hence RVC/RVT controller will be off) in case of over temperature above 60°C (or 140°F) inside the enclosure. In such event, all the capacitors are switched off while fans keep running. Thermal cutoff switch automatically closes when temperature goes down to normal conditions.



DANGER

When the thermal protection switches on, RVC/RVT controller is off but the capacitor bank is still connected to the power supplies.



Figure 9: Thermal cutoff switch



Figure 10: Location of thermal cutoff switch in APC03



Figure 11: Location of thermal cutoff switch in APCM03 and APCR03

5 Installation

5.1 Working conditions: dust, moisture and temperature

The APC03 capacitor banks are for indoor installation only. Protect your APC03 against dust and moisture and place it in a well-ventilated area where the ambient temperature doesn't exceed the following values:

- 40°C (or 104°F) maximum.
- 35°C (or 95°F) over 24h.
- 25°C (or 77°F) over one year.

5.2 Harmonics pollution

The installation of a capacitor bank on networks polluted by harmonics requires special precautions to avoid any risk of resonance.

In such case, consult your ABB Power Quality specialist.

Only the APCR03 bank includes de-tuning reactors which enable the capacitor bank to operate in polluted network up to a THDV of 8% with following spectrum:

- $U3/U1 = 0.5\%$ $U5/U1 = 6.0\%$
- $U7/U1 = 5.0\%$ $U11/U1 = 3.5\%$
- $U13/U1 = 3.0\%$

5.3 Mechanical installation

5.3.1 APCL03 capacitor banks

- To be fixed on a wall with 4 fixation points located as per below drawing.

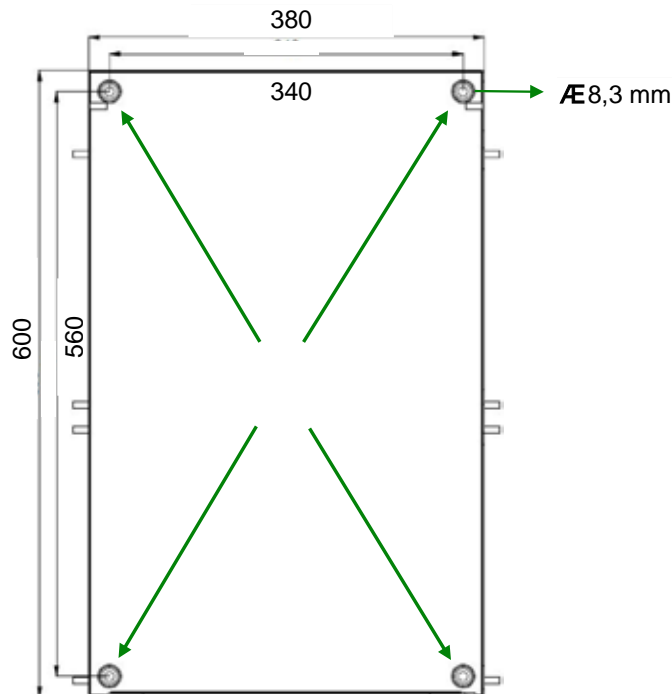

Figure 12: APCL03 fixing points

- APCL03 weight: max 65 kg.
- At least M8 screw must be used. The anchors should enable a 5 mm fixture thickness.

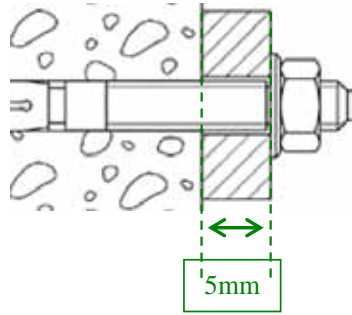

Figure 13: Anchor fixture details

- Minimum clearance at any side (but the back) of the APCL03 unit is 100 mm.

5.3.2 APCM03 and APCR03 capacitor banks

- Free floor standing cubicles - minimum clearance distance at the back: 50 mm.
- Can be placed immediately side by side with other cubicles
- Lateral panels **CANNOT** be removed, even if cubicles are side by side.

5.4 Electrical installation

5.4.1 Electrical insulation test

All APC03 are fully factory tested including an insulation test between power terminals and earth (2500V 50Hz 10s).

If additional insulation test is required on site, the following procedure should be followed:

- Short-circuit the three busbars.
- Apply between earth and short-circuited busbars 2000V 50Hz 10s.

Any damage resulting of this test should be notified immediately to your local ABB agent.

Remove short circuit after the test.

5.4.2 Electrical connections overview

Each APC03 cubicle requires individual:

- Earth connection
- Power connection
- Auxiliary power supply connection (230V 50Hz or 120V 60Hz) which has to be provided locally except if optional auxiliary transformer is ordered (then no auxiliary power connection is required).
- Current transformer (CT) connection.

Each APC03 cubicle is equipped with a power release contact for switching on and off the whole APC03 capacitor bank remotely.

5.4.3 Earth connection

- APCL03 earth connection: one M6 stud located inside the bank plate next to the lower left corner.



Figure 14: Earth connection in APCL03

- APCM03 and APCR03 earth connections: two M8 bolt located on an earthing bar (either on top or bottom acc to cable entry).

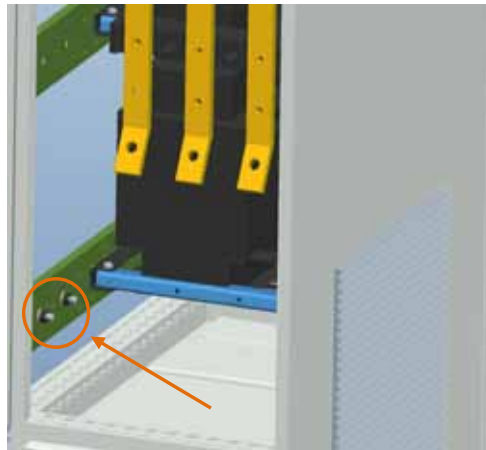

Figure 15: Earth connection in APCM03 and APCR03 for bottom cable entry



Figure 16: Earth connection in APCM03 and APCR03 for top cable entry

5.4.4 Power cables selection

Cables and isolating switchgear should be rated at **1.5 times** the nominal capacitor bank current rating and it should always be coordinated with the current rating of the backup fuses.

Note: when selecting the appropriate cable, please also consider possible future extension of the equipment (i.e. additional power modules).

Cross section of supply cables

The different parameters like localization, temperature, etc... and other factors which may exist, do not allow covering all the possible cases of installation and simple rules. The standards in force in the concerned country have to be taken into consideration keeping in mind that the current must be considered as a minimum 1.5 times the nominal current.

Master switch, fuses and circuit breaker

At the location of the bank installation, the power of the network short-circuit must be taken into consideration to define the main connection fuses, or rating of the circuit breaker.

To disconnect the unit from the network, ABB suggests preferably a circuit breaker. A 3-phase disconnecting fuse or a 3-phase switch with fuses may nevertheless be used.

The circuit breaker should be chosen with a nominal current rating of minimum **1.5 times** the rating of the capacitor bank.

However, the fuses must be calibrated at least at **1.6 times** the rating current of the capacitor bank.

5.4.5 APCL03 electrical connections

- Electrical connection from bottom only.



Figure 17: APCL03 bottom entry

- Unscrew the bottom plate (1.5 mm thickness, painted steel) and pass all cables through.
- Connect earth (see 5.4.3).
- Connect the power cables to busbars.

Thickness: 30/10 mm

Hole diameter: 11 mm

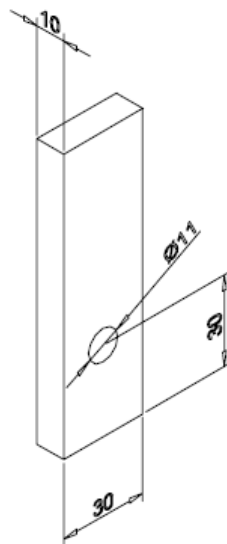

Figure 18: APCL03 power cables connection to busbars

- Connect CT cable.
- Connect auxiliary power supply (unless auxiliary transformer ordered).



Figure 19: APCL03 cables connection

- Make sure the bottom plate is properly mounted back.

5.4.6 APCM03 and APCR03 electrical connections – Bottom entry

- The APCM03 and APCR03 cubicles are bottom cable entry by default (for optional top entry, refer to 5.4.7).
- Unscrew the bottom plate (1.5 mm thickness, zinc plated steel) and pass all cables through.

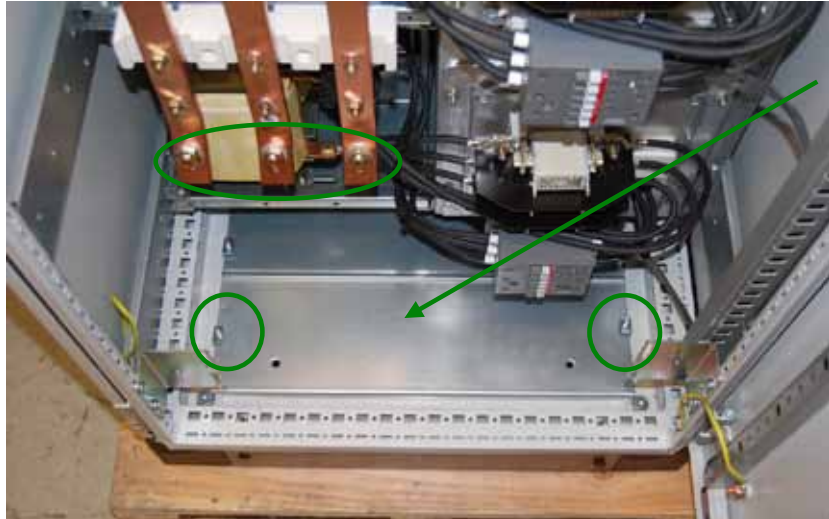

Figure 20: APCM03 and APCR03 bottom entry

- Connect earth (see 5.4.3).
- Connect the power cables to busbars.

Thickness: $L = 30 / T = 10$ mm up to 300 kvar 400V or 40 / 20 mm (above 300 kvar)

Hole diameter: 13 mm

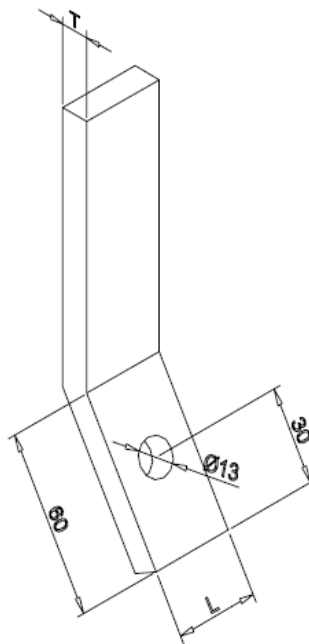

Figure 21: APCM03 and APCR03 power cables connection to busbars

- Connect CT cable.
- Connect auxiliary power supply (unless auxiliary transformer ordered).

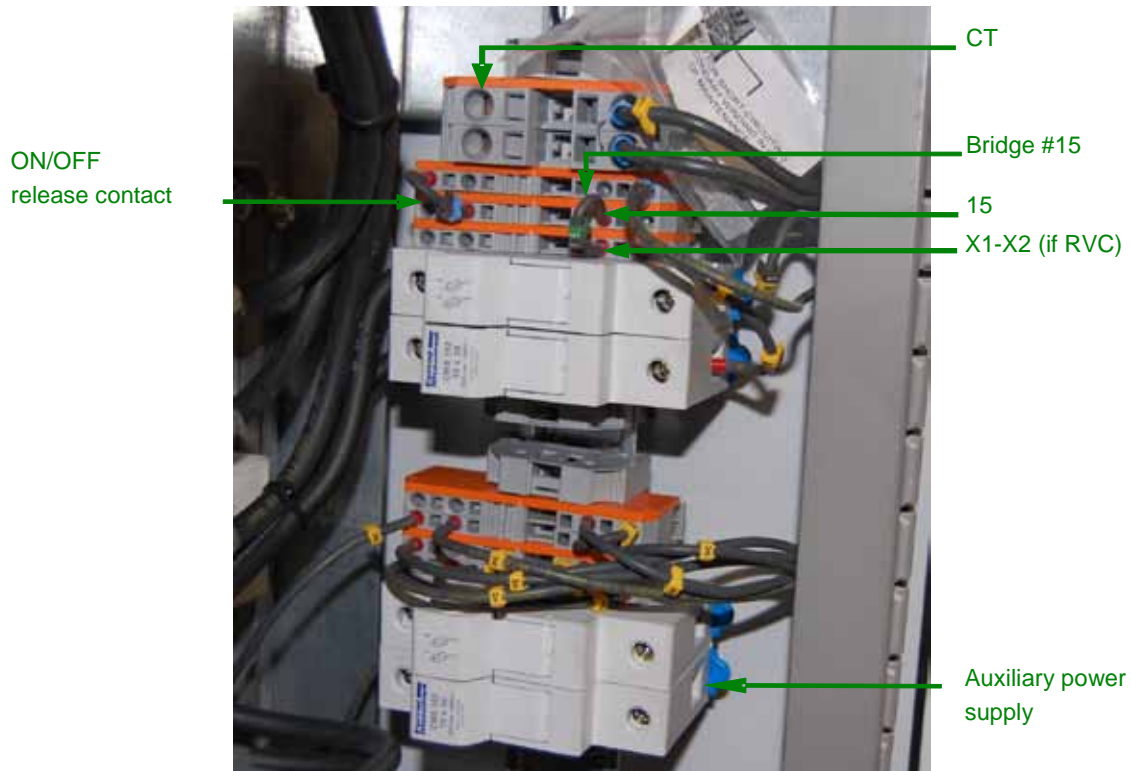

Figure 22: APCM03 and APCR03 auxiliary connections

- Make sure the bottom plate is properly mounted back.

5.4.7 APCM03 and APCR03 electrical connections – Top entry

- Unscrew the two plates (190 x 100 mm, 2 mm thickness, Aluminum) of the cubicle and pass all cables through.

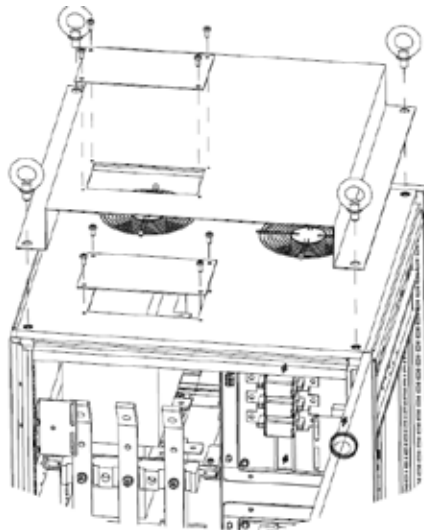

Figure 23: APCM03 and APCR03 top cable entry

- Connect earth (see 5.4.3).
- Connect power cables to busbar.
- For all other connections: please refer to previous section 5.4.6.

5.4.8 Auxiliary power supply

Each APC03 cubicle requires an auxiliary power supply connection (230V 50Hz or 120V 60Hz) which has to be provided locally unless optional auxiliary transformer is ordered.

Auxiliary power supply has to be connected to auxiliary power terminals, as per section 5.4.5 and 5.4.6.

Power supply ratings:

- APCL03: 150 VA
- APCM03 and APCR03: 250 VA

5.4.9 Optional auxiliary transformer

When optional auxiliary transformer is ordered, there is no need for auxiliary power supply connection (factory cabling).

5.4.10 Current transformer selection

Current transformer (CT) has to be provided locally (not provided with APC03).

A range of ring and split core CTs exists on the market to ease installation.

CT connection must be in closed loop. It means that the CT should monitor the total current (i.e. both the load current and APC03 current).

CT specification:

- 1 or 5 A secondary current rating.
- 15 VA burden for up to 30 meters with 2.5 mm² cable. For longer cables lengths refer to [Figure 24](#) here below. In case of the CT is shared with other loads, the VA burden shall be adapted accordingly.
- Class 1 resolution or better.
- Primary side current rating should be sufficient to monitor the total line current (including transient phenomena such as drive/motor starts).

The APC03 bank is provided with ABB RVC/RVT controller with automatic adaptation to network phase-rotation.

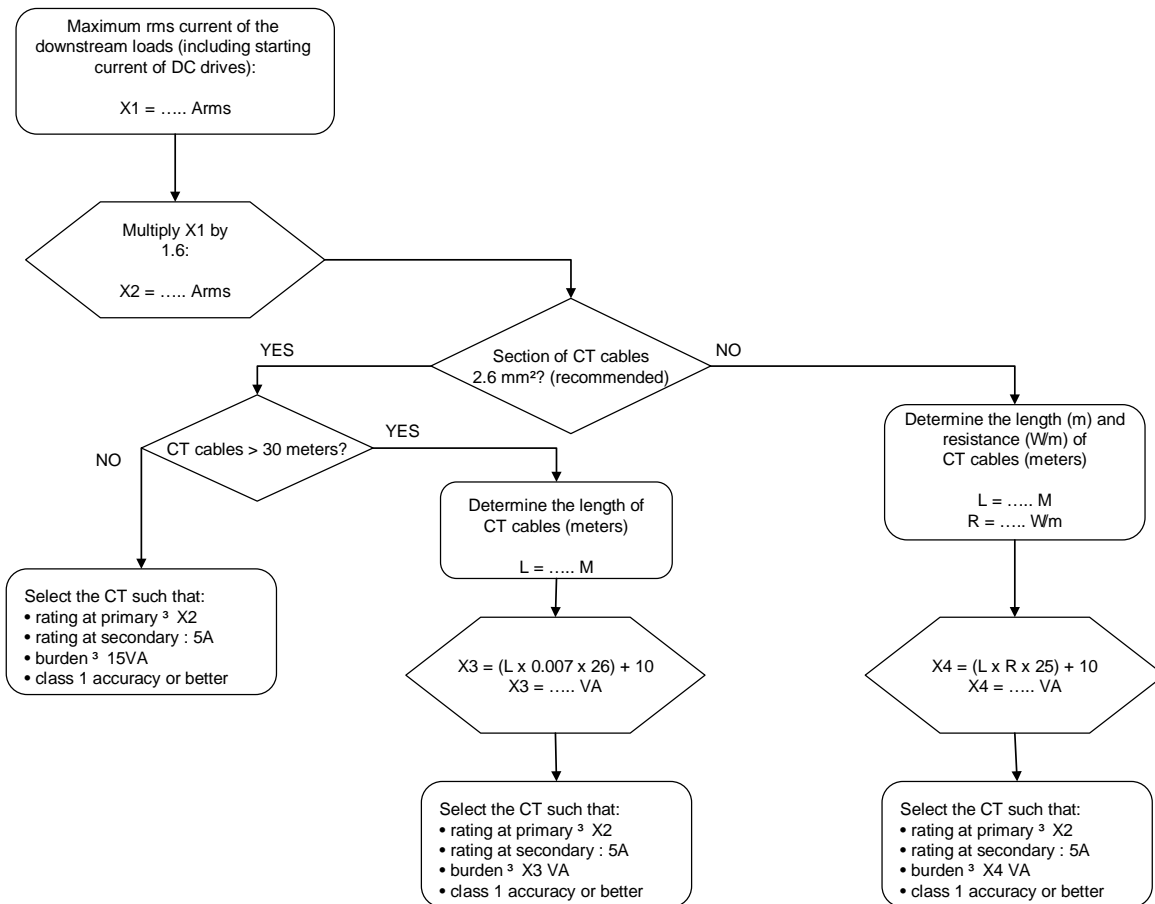

Figure 24: Flow chart for CT determination

5.4.11 Current transformer connection



WARNING: When connecting the CT(s), the secondary terminals of each CT have to be shorted. Failure to do so may result in CT destruction and consequent damage to the installation. Once the connections to the APC03 have been made, remove the short circuit.

WARNING: CT can be connected to several equipments BUT must be in series.

CT must be connected to CT's terminals as per 5.4.5 and 5.4.6.

The CT terminal block can handle control cable wiring with sections from 0.75 mm² to 10 mm².

Run CT cables inside the cubicle. The cables can be installed in the cable duct fixed on the right of the cubicle.

CT's are normally marked P1/P2 and S1/S2 and should face the supply transformer while P2 the load side.

S1 control wires terminal goes to terminal marked k and S2 to terminal marked l.

Note: A gray jumper is provided with the bank in a small plastic bag. Use this gray jumper in case shorting of the CT secondary winding is required (e.g. RVC/RVT controller removal). As long as the RVC/RVT controller remains wired to the capacitor bank, the gray jumper must be removed for proper operation of the bank.

5.4.12 Multi ratio CT and summation transformer

When a multi ratio split core CT is used the appropriate ratio is selected by connecting either S2 or S3 or S4 to terminal marked I. The CT ratio should be selected as close as possible to the requested CT specification.

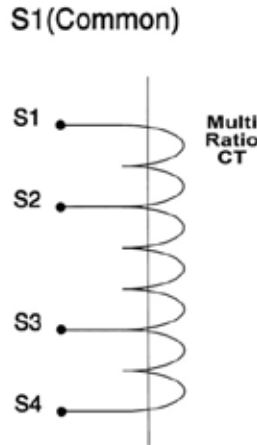

Figure 25: Multi ratio CT

Summation transformer

For more complex situation (i.e.: two or more power source connections) the current has to be measured in different points in order the APC03 receives correct measurement in any circumstances.

Then, when several CT's are requested, one or several summing transformer should to be used.

When a summation current transformer is used the terminal markings will usually be P1, P2, P3, P4 and S1, S2. The secondary connections S1 and S2 should be connected to K and I respectively as before.

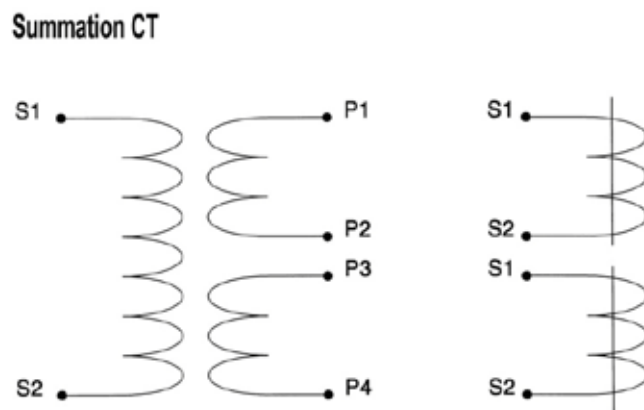

Figure 26: Summation CT

The first CT should be connected to P1 and P2 while the second CT should be connected to P3 and P4 on the summation CT. **It is important that all CT's monitor current in the same direction.**

5.4.13 ON/OFF release contact

All APC03 are fitted with a release contact which allows for switching on and off the whole APC03 capacitor bank remotely.

The release contact is internally fed under 230V 50Hz or 120V 60Hz. The contact could draw up to 15VA.

Make sure the switch used for this feature is free from potential and is designed for the above-mentioned power and voltage.

Procedure:

- Before cabling the contact, disconnect the whole APC03 bank from all power supplies.
- Remove the connection wire (jumper) situated next to the gray CT jumper as per [Figure 19](#) and [Figure 22](#).
- Connect the cable for remote control in place of the jumper.
- Only when the contact is closed the Power Factor controller is fed and the bank operates.

5.4.14 Connection of several banks in parallel

Several APC03 capacitor banks can be connected in parallel.

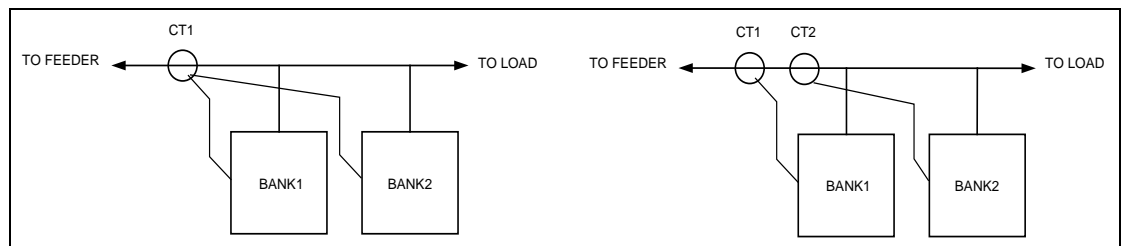

Figure 27: Connection of several capacitor banks in parallel

The parameter “switching delay” of each RVC/RVT Controller must be set differently.

If the RVC/RVT controllers are set to normal mode, we recommend using a switching time delay difference of 1 sec. (e.g. 40s, 41s, 42s ...).

If the controllers are set to integral mode, we recommend using a switching time delay difference of at least 21 sec. (e.g. 120s, 141s, 162s ...).

5.4.15 Circuit breaker connections

If circuit breaker is ordered, power terminals should be connected to the circuit breaker directly as per figure here below:

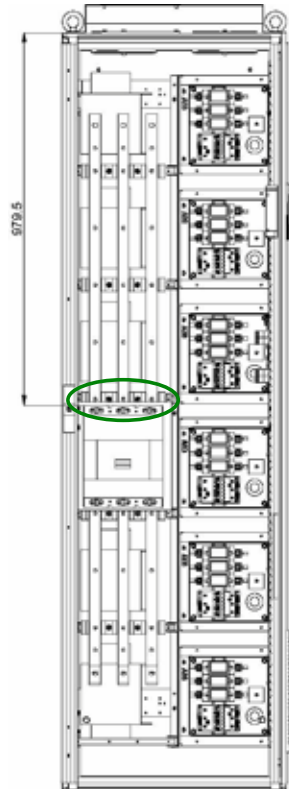

Figure 28: connection for top entry

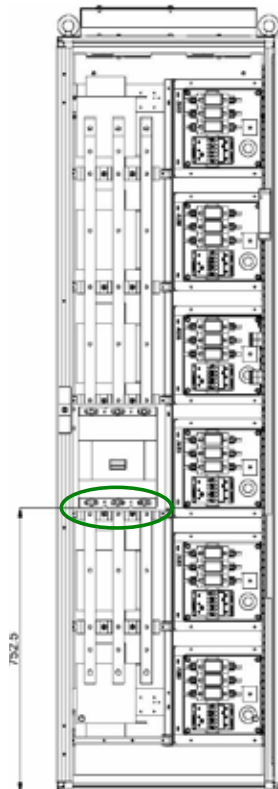

Figure 29: connection for bottom entry

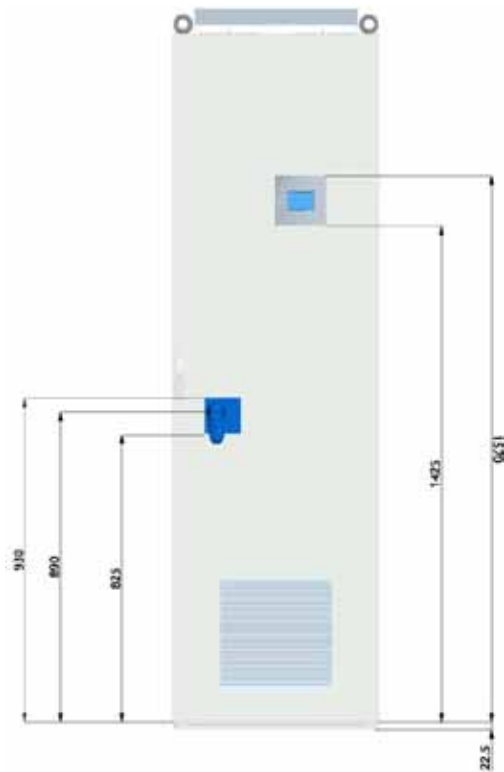
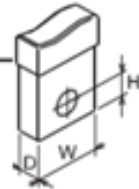

Figure 30: External layout with circuit breaker

Front terminals - F

Allow connection of busbars or cables terminated with cable terminal



Type	Version	Pieces	Busbars/cable terminal [mm]				Tightening [Nm]
			W	H	D	Ø	
T2	F-P	1	20	7.5	5	6.5	6
T3	F-P	1	24	9.5	8	8.5	8
T4	F	1	25	9.5	8	8.5	18
T5	F	1	35	11	10 ⁽¹⁾	10.5	28
T6 630	F	2	40	12	5	2 x 7	9
T6 800	F	2	50	12	5	2 x 7	9
T7 1250⁽²⁾	F	2	50	20	8	2 x 11	18
T7 1600	F	2	50	20	10	2 x 11	18

⁽¹⁾ minimum 5 mm

⁽²⁾ up to 1250 A

Pieces = Number of busbars, cables or cable terminals

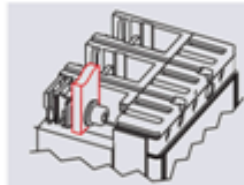

F = Front terminals

6 Easy commissioning

1. General check of the capacitor bank: tightness of all connections, earth, fuses, contactors, etc.
Note: the APC03 should be isolated from all power supplies (power and auxiliary).
2. Check cable cross sections and fuses: they should be compliant to the capacitor bank rating.
3. Check that the CT('s) is (are) properly installed (closed loop) and connected.
4. Remove the CT short circuit.

Note: If your APC03 is equipped with an optional RVT, refer to RVT instruction manual and don't follow the points below.

5. Switch on main and auxiliary power supplies (auxiliary supply may not be required if optional auxiliary transformer ordered).

Note: after a power outage, there's a reset time. During this period of time, the disconnection icons will be blinking and the alarm contact will remain closed. After, the APC03 will resume its normal operation.

Check that the fan(s) are working properly.

If not working properly, refer to Chapter 7.

6. RVC Power Factor Controller auto setting.

WARNING: if several units are connected in parallel, please refer to 5.4.14.

WARNING: The parameter "switching delay" of the RVC should be higher than 40 s. Lower value may damage your capacitor bank.

Activate the AUTO SET Mode by pressing twice the Mode button. "Au" appears on the LCD display.

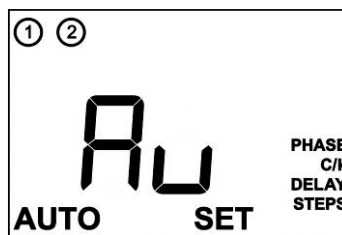

Figure 31: View of the AUTO SET mode in RVC

Press the + button once: Phase, C/k, and Delay parameters will appear. Steps have been already set in factory.

Press the + and – buttons simultaneously to start the automatic setting.

"Au" starts flashing. Phase, C/k and Delay parameters are automatically set. Note that the delay value remains unchanged if it is set above or equal to 40 sec. before commissioning.

If an error is detected, the AUTO SET procedure is stopped and an error message is displayed.

For more details, please refer to RVC manual.

7. Setting target $\cos \phi$.

Press the Mode button once to activate manual setting of target $\cos \phi$.

The previous value will appear. If the RVC has never been programmed before, "100" appears on the LCD display.

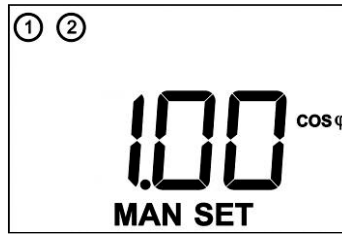



Figure 32: View of target $\cos \phi$ setting

Set your target $\cos \phi$ by pressing either the – or + button.

 indicates an inductive PF and  indicates a capacitive $\cos \phi$.

8. Reactivate the AUTO Mode by pressing the mode button repeatedly.

During this procedure, the parameters previously set will be displayed first: Phase, C/k, Delay and Steps.

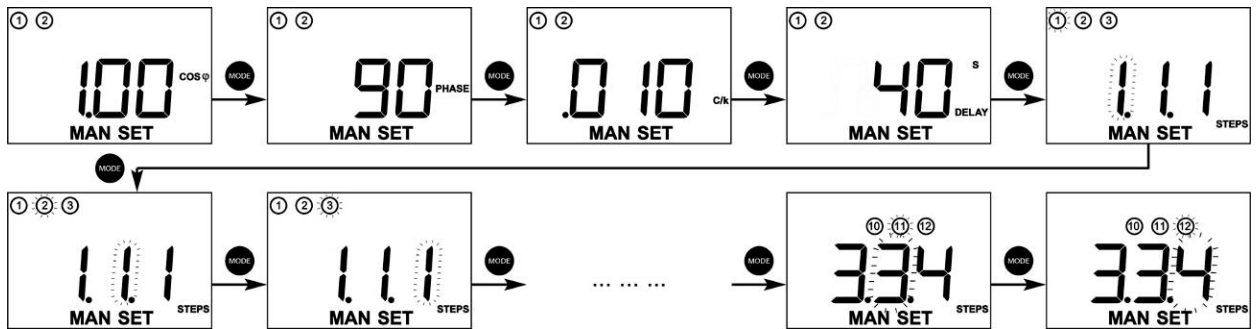

Figure 33: View of programmable parameters

Then, select: Feature 1 (linear / circular) and Feature 2 (generative / regenerative target $\cos \phi$).

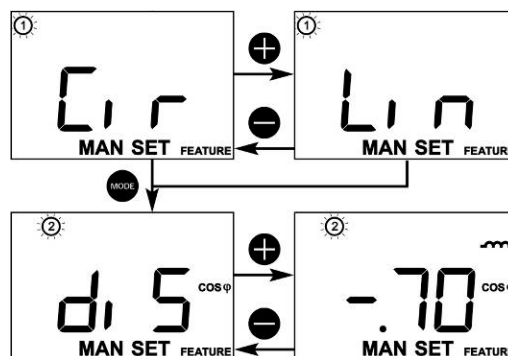

Figure 34: View of the "Feature" parameters

Finally, set the protections: Protection 1 (overvoltage - Max Vrms), Protection 2 (undervoltage - Min Vrms) and Protection 3 (over THDV - Max THDV).

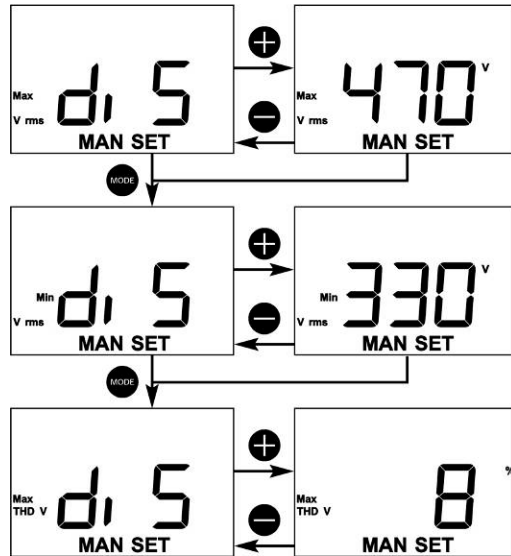

Figure 35: View of the Protections parameters

Once back in AUTO Mode, the RVC automatically switches on the necessary steps to reach the programmed target $\cos \phi$.

The actual $\cos \phi$ appears on the LCD display.

Note: a negative $\cos \phi$ indicates that the load is re-injecting reactive power on the network. The RVC continues to work normally.

For RVT, please refer to RVT manual provided within the capacitor bank.

7 Troubleshooting

Most of the APC03 operating problems may be identified with the help of error messages or icons display on the RVC/RVT controller. Refer to the troubleshooting paragraph of the RVC/RVT controller instruction manual.

If the RVC/RVT controller is properly connected but nothing appears on its display, this may be due to one of the following reasons (by order of precedence):

- No power supply (check the wiring, fuses, etc...).
- ON/OFF release contact for remote control is left open in a remote room.
- Thermal cut-off switch fails or opens due to too high temperature (> 60°C or 140°F) in the cubicle. RVC/RVT controller is thus no longer fed. This high temperature may be due to an ambient temperature (i.e. outside the bank enclosure) above the maximum allowed temperature. (> 40°C or 104°F).
- Failure of both fans and thermal cutoff switch. This would end up in such a higher temperature that the internal protection of RVC/RVT controller activates (about 85°C or 185°F).
- Faulty RVC/RVT controller.

8 Maintenance

All maintenance operations should be carried on by qualified electrician. Please refer to [Chapter 2](#).

The interval between two maintenances will depend on working conditions but should not be longer than one year.

Regular maintenance procedure:

- Check ambient temperature and equipment ventilation (should be within specification).
- Isolate the APC03 from power supplies (including auxiliary power supply).
- Open the front door panel and remove internal grid.
- Clear air inlet and outlet.
- Clean all parts from dust and dirt.
- Check fuses (shouldn't be brown).

Replace internal grid and energize the APC03:

- Switch on each power step manually with RVC/RVT controller.
- Check contactors and their good operation – replace them if necessary.
- Check operation of RVC/RVT Controller.
- Measure capacitors currents (in the three phases) for every power step and record the measurements.

Note: current measurements should be compared to previous measurements. If current is 10% lower than first measurement, capacitors have to be replaced.

Nominal current is normally given by: $I_n = \frac{Q_x}{U_n \sqrt{3}}$

Where:

- I_n = current in one phase
- Q_x = Reactive power (kvar) on the power step
- $\sqrt{3}$ = square root of three
- U_n = RMS value of phase to phase voltage

Fan replacement:

Fans have to be replaced every 5 years (40 000 hours).

9 Dimensions and weights

Type	H (mm)	W (mm)	D (mm)	Weight
APCL03	600	770	350	Max 65 kg
APCM03	2075	600	600	Max 280 kg
APCR03	2075	600	600	Max 465 kg

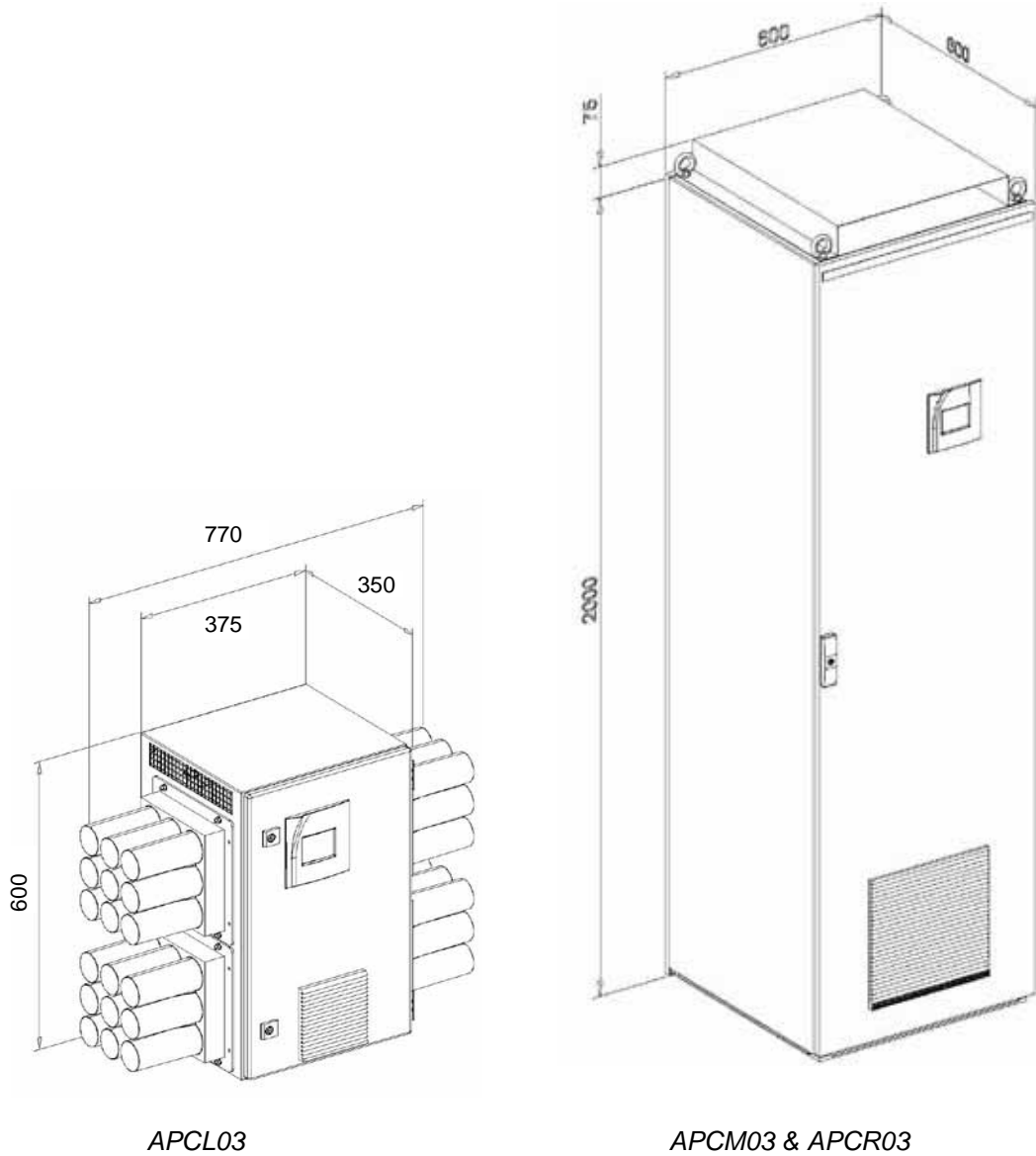

APCL03

APCM03 & APCR03

Figure 36: APC03 series dimensions and weights

10 Technical Specifications

Voltage range	400V and 415V at 50Hz 380V and 480V at 60Hz For other voltages, please consult us.
Working ambient temperature	-5°C (23°F)/+40°C (104°F) according to EN 61921
Installation	- APCL03: wall mounting, bottom cable entry Clearance lateral & top: 100 mm - APCM03 and APCR03 cubicles: free floor standing, bottom cable entry. (top cable entry optional) Clearance lateral & back: 50 mm (but no clearance required between two APC03 cubicles)
Connection	Three-phase, balanced network.
Protection	- APCM03 and APCR03: IP23 (closed door) - APCL03: IP21 (closed door) - Protected against direct and accidental contact (open door)
Execution	Indoor
Color	Beige RAL 7035
Ventilation	Forced air cooling
Power factor setting	From 0.7 inductive to 0.7 capacitive
Starting current setting (C/k)	From 0.01A to 3A for the RVC controller From 0.01A to 5A for the RVT controller (optional)
Operation	During operation, RVC (RVT) controller displays: - the number of active outputs - the inductive or capacitive power factor - the alarm conditions: target $\cos \phi$, over/undervoltage, THDV, overtemperature - the demand for switching on/off a capacitor step
Losses at 400V 50Hz	- Without reactors: less than 1.5 Watt/kvar - With reactors: less than 5.5 Watt/kvar
Capacitors – CLMD03 type	- Dry type self healing according to IEC 60831 – 1&2 - Dielectric: 2.15 Un between terminals during 10 sec at rated frequency - Acceptable overvoltage: +10% max. intermittently - Acceptable overcurrent: +30% permanently - Temperature range: -25°C (-13°F) / class D according to IEC 60831 – 1&2
Reactors (APCR03 only)	- Dry type resin embedded according to IEC 289, IEC 76 - Maximum harmonic pollution: 8% THDV with specific spectrum: U3/U1 = 0.5% U5/U1 = 6% U7/U1 = 5.0% U11/U1 = 3.5% U13/U1 = 3.0%
Standards	EN 61921 CE marked
Options	RVT controller Top cable entry Circuit breaker Temperature probe (with RVT only) Auxiliary transformer 100 or 200 mm base frame

11 Contact us

ABB n.v.

Power Quality Products

Avenue Centrale 10

Zoning Industriel de Jumet

B-6040 Charleroi (Jumet), Belgium

Phone: +32(0) 71 250 811

Fax: +32 (0) 71 344 007

E-Mail: Power.Quality@be.abb.com

www.abb.com/lowvoltage