



Warning! Dangerous electrical voltage!

Before commencing the installation

- Disconnect the power supply of the device.
- Ensure that devices cannot be accidentally restarted.
- Verify isolation from the supply.
- Earth and short circuit.
- Cover or enclose neighbouring units that are live.
- Follow the operating and installation instructions of the device concerned.
- Only suitably qualified personnel in accordance with EN 50110-1/-2 (VDE 0105 Part 100) may work on this device/system.
- Before installation and before touching the device ensure that you are free of electrostatic charge.
- The functional earth (FE) must be connected to the protective earth (PE) or to the potential equalisation. The system installer is responsible for implementing this connection.
- Connecting cables and signal lines should be installed in such a way that inductive or capacitive interference does not impair the automation functions.
- Install automation devices and related operating elements in such a way that they are well protected against unintentional operation.
- Suitable safety hardware and software measures should be implemented for the I/O interface so that a line or wire breakage on the signal side does not result in undefined states in the automation devices.
- Ensure a reliable electrical isolation of the low voltage for the 24 volt supply. Only use power supply units complying with IEC 60364-4-41 (VDE 0100 Part 410) or HD 384.4.41 S2.
- Deviations of the mains voltage from the rated value must not exceed the tolerance limits given in the specifications, otherwise this may cause malfunction and dangerous operation.
- Emergency stop devices complying with IEC/EN 60204-1 must be effective in all operating modes of the automation devices. Unlatching the emergency-stop devices must not cause restart.
- Devices that are designed for mounting in housings or control cabinets must only be operated and controlled after they have been installed with the housing closed. Desktop or portable units must only be operated and controlled in enclosed housings.

- Measures should be taken to ensure the proper restart of programs interrupted after a voltage dip or failure. This should not cause dangerous operating states even for a short time. If necessary, emergency-stop devices should be implemented.
- Wherever faults in the automation system may cause damage to persons or property, external measures must be implemented to ensure a safe operating state in the event of a fault or malfunction (for example, by means of separate limit switches, mechanical interlocks etc.).

Table of Contents

<hr/>	
About this manual	3
Explanation of terms	3
Additional manuals	4
Reading conventions	4
<hr/>	
1 About the remote display	5
Intended users	5
Proper use	5
Overview	6
– Remote display at a glance	8
Operation	10
Main menu	11
<hr/>	
2 Installation	13
Mounting	13
– Mounting protective cover CL-LAD.FD001	14
– Mounting protective cover CL-LAD.FD011	15
– Mounting the display module (front mounting)	18
– Demounting the display module (front mounting)	20
– Mounting remote display connection module	21
– Demounting remote display connection module	22
Connections	22
– Terminals	22
– Connecting the power supply	23
– Connecting connection cable	24
<hr/>	
3 Commissioning	27
Switching on	27
Initial commissioning	28

4	Device application	29
	Point-to-point connection	29
	CL-NET operation	30
	Connection faulty	31
	Graphic mode on the remotely operated device	31
5	Settings	33
	Station selection	33
	Setting the menu language	34
	Changing the lighting	35
	Changing the contrast	36
6	Appendix	37
	Dimensions	37
	– Display module CL-LDD...	37
	Technical data	38
	– General ambient conditions	38
	– Display module CL-LDD...	40
	– Protective cover CL-LAD.FD001	42
	– Protective cover CL-LAD.FD011	42
	– Remote display connection module CL-LDC.S...	43
	Index	45

About this manual

This manual describes the installation, commissioning and possible settings on the remote display.

Explanation of terms

The remote display described here consists of the CL-LDC.S... remote display connection module, the CL-LDD... display module and a CL-LAD.TK007/CL-LAD.TK005 connection cable to the CL basic units.

If the remote display is connected with a CL basic unit, it can be used to read the text and status display of the basic unit or operate the basic unit remotely via the keypad.

The following tables shows the individual components of the display/operator system with their type designations. Components that can be ordered are indicated by a grey background.

Table 1: Components of the remote display with type designation and possible order combinations

Display-/ Module	Remote display- connection module	Connection cable to CL basic units
CL-LDD.XK CL-LDD.K		CL-LAD.TK007 CL-LAD.TK005
	CL-LDC.SAC2 CL-LDC.SDC2	

Additional manuals

The CL-LDC.S... can be connected to CL-LSR/CL-LST, CL-LMR/CL-LMT or CL-LDC.L... basic units.

These CL basic units are described in separate manuals:

- Logic relay (1SVC 440 795 M0000)
- Display system (1SVC 440 795 M1000).

All manuals can be downloaded as PDF files from the Internet. It is available on the Internet at:
<http://www.abb.com/lowvoltage> --> Control Products.

Reading conventions

Symbols used in this manual have the following meanings:

► indicates actions to be taken.



Attention!

Warns of the risk of material damage.



Caution!

Warns of the possibility of serious damage and slight injury.



Warning!

Indicates the risk of major damage to property, or serious or fatal injury.



Draws your attention to interesting tips and supplementary information.

For greater clarity, the name of the current chapter is shown in the header of the left-hand page and the name of the current section in the header of the right-hand page. This does not apply to pages at the start of a chapter and empty pages at the end of a chapter.

1 About the remote display

Intended users

The CL-LDC.S... must only be installed and connected up by trained electricians or persons familiar with the installation of electrical equipment.

A specialist knowledge of electrical engineering is needed for commissioning. When controlling active components such as motors or pressure cylinders, parts of the system can be damaged and persons put at risk if the CL-LDC.S... is connected or programmed incorrectly.

Proper use

The CL-LDC.S... must be properly installed before use:

- The CL-LDD.XK/CL-LDD.K display module is protected to IP 65 and does not normally need any special housing protection.
- The rear of the CL-LDC.S... unit is designed as a mounting unit and must be installed in an enclosure, control cabinet or a service distribution board.
- The installation must comply with regulations for electromagnetic compatibility (EMC).
- The power up of the CL-LDC.S... must not cause any hazards arising from activated devices, such as unexpected motor startups or power ups.

Overview

In conjunction with the connected CL-LSR/CL-LST, CL-LMR/CL-LMT or CL-LDC.L... basic units, the remote display fulfills the following tasks:

- Display on the CL-LDC.S... of the status or text display of the connected basic unit.
- Remote operation of the connected basic unit via the CL-LDC.S... keypad.

The devices can be linked together easily via the serial interface.

If the remote display is connected to a CL basic unit in the CL-NET network, it can be used for operating each device on the CL-NET and displaying their display content. This is possible regardless of the device in the CL-NET to which the remote display is connected.

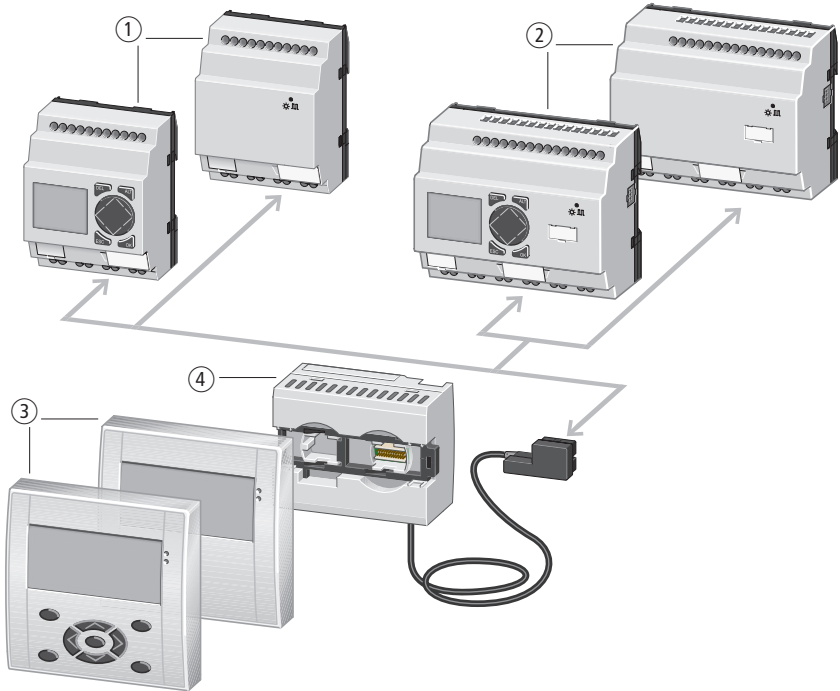

Figure 1: System overview

- ① CL-LSR/CL-LST logic relays
- ② CL-LMR/CL-LMT logic relays
- ③ CL-LDC.XK/CL-LDC.K display module
- ④ CL-LDC.S... remote display connection module with connection cable

Remote display at a glance

The remote display consists of the remote display connection module and the display module.

Display module

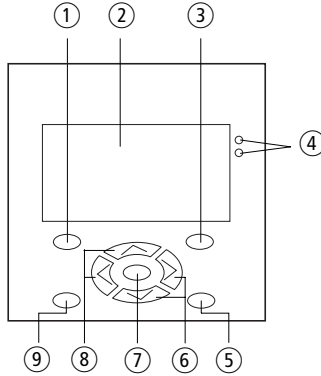

Figure 2: Display module

- ① DEL key
- ② Graphic display
- ③ ALT key
- ④ LEDs for signalling
- ⑤ Mode button
- ⑥ Right, down cursor buttons
- ⑦ OK key
- ⑧ Left, up cursor buttons
- ⑨ ESC button

Remote display connection module

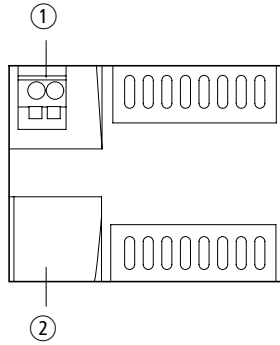

Figure 3: Remote display connection module

- ① Supply voltage
- ② Serial interface for point-to-point connection

Operation

The buttons on the display module have the following functions:



Move to next menu level, call menu item activate, change, store entries



Move to previous menu level, cancel entries since last **OK**



^ v Change menu item
< > Change value
Change place



Toggle between Terminal mode and main menu.

Main menu

Status display

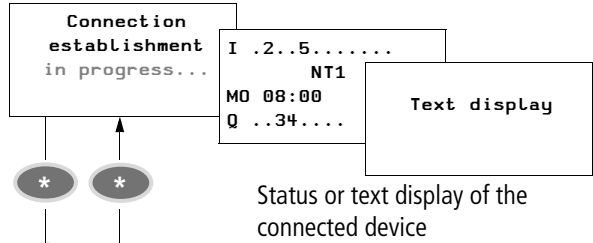

Main menu
Current selection flashes in CL-LDC.S... menu

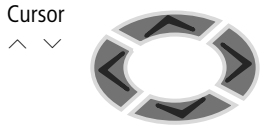
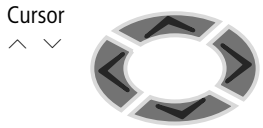
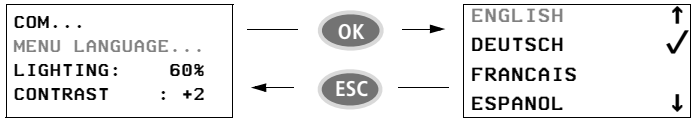
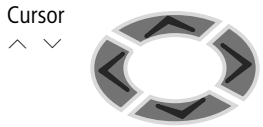
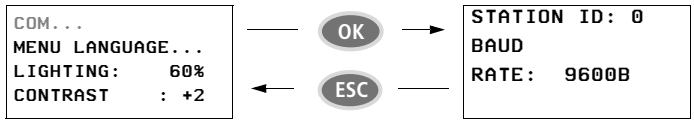

Setting values

```

COM...
MENU LANGUAGE...
LIGHTING: 60
CONTRAST : +2

```



```

COM...
MENU LANGUAGE...
LIGHTING: 60%
CONTRAST : +2

```

Selection mode: Black rectangle flashing

or

Entry mode: Number flashing



Press **OK** to toggle between Selection and Entry modes.

Press **OK** or **ESC** to move from Entry mode to Selection mode of the main menu

```

COM...
MENU LANGUAGE...
LIGHTING: 60%
CONTRAST : +2

```



^ v Change value

The result of the value change is immediately visible

Special function



If the remotely operated device is a display system in graphic mode, this button combination can be used to close the graphic mode on this device. The button „*” has the same function on the remotely operated local display system.

2 Installation

The CL-LDC.S... must only be installed and connected up by trained electricians or persons familiar with the mounting of electrical equipment.

The CL-LDC.S... is installed in the following order:

- Mounting,
- Connecting the serial interface,
- Connecting the power supply.

Mounting

Install the display module in the front of a control cabinet, a service distribution board, operator panel or in an enclosure. You can protect the display module with a protective cover, depending on the environment in which it is to be used. This must be fitted before the CL-LDC.S... is mounted and is therefore described below.

When installing the CL-LDC.S... remote display connection module, all connections must be protected against liquid and dust.

For sufficient heat circulation around the device, the rear of the CL-LDC.S... and the terminals must have a clearance of at least 3 cm from the wall or adjacent devices.

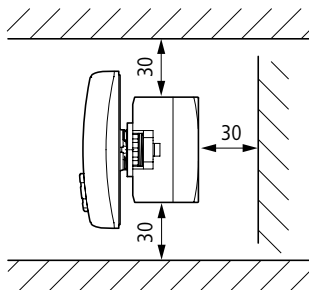

Figure 4: Minimum clearance to CL-LDC.S...

Mounting protective cover CL-LAD.FD001

For special applications such as in the food industry, the keypad must be protected against the ingress of dust, liquids etc. In this case fit a CL-LAD.FD001 protective cover over the display module .



Mount the CL-LAD.FD001 protective cover before mounting the display module.

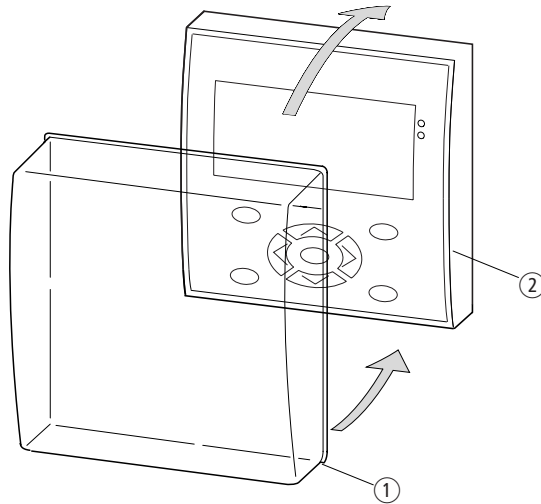

Figure 5: Mounting the CL-LAD.FD001 protective cover

- ① Protective cover
- ② Display module



Caution!

Ensure that the CL-LAD.FD001 protective cover is fitted in the groove of the display module.

Otherwise a proper seal cannot be guaranteed and particles may enter underneath the protective cover. This may cause malfunctions in the keypad.

In food industry applications, there is the risk of bacteria building up underneath the protective cover.

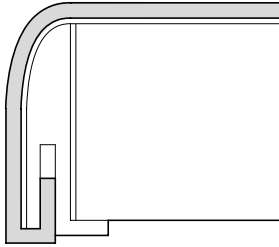

Figure 6: Correct position of the CL-LAD.FD001 protective cover



Remove the display module in order to replace the CL-LAD.FD001 protective cover. Replace the cover and remount the device.

Mounting protective cover CL-LAD.FD011

The protective cover CL-LAD.FD011 is provided for using the device in aggressive environments. This protects the display and the operating unit against mechanical damage or destruction. Protection to IP 65 is maintained.

The protective cover CL-LAD.FD011 can be opened so that the operating unit can be used.

The protective cover CL-LAD.FD011 can be closed with a sealing facility to provide protection against unauthorised operation.



Fit the CL-LAD.FD011 protective cover before mounting the display module.

► First remove the front frame before mounting.

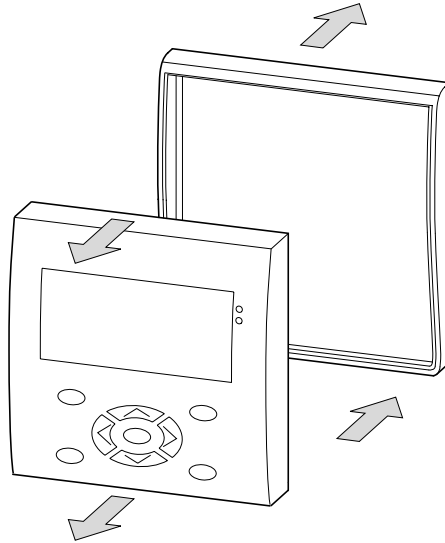

Figure 7: Removing the front frame

The protective cover CL-LAD.FD011 can be mounted in two different positions.

► Choose the position that is most suitable for the application at hand and your requirements.

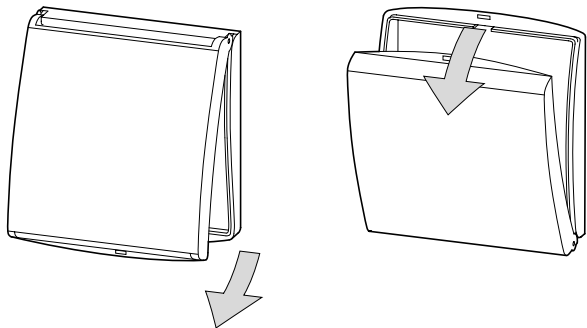

Figure 8: Position protective cover CL-LAD.FD011

- Mount the protective cover CL-LAD.FD011 as shown in the figure.

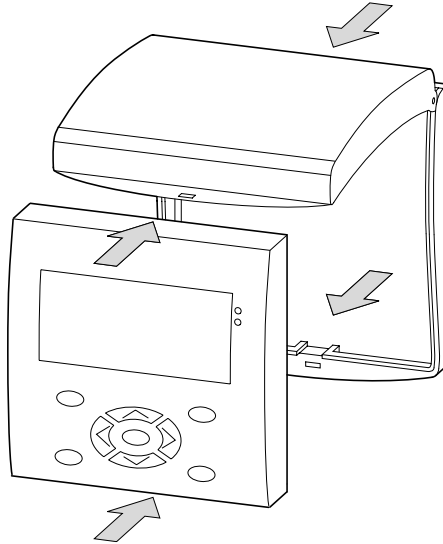

Figure 9: Mounting the CL-LAD.FD011 protective cover

Sealing the protective cover CL-LAD.FD011

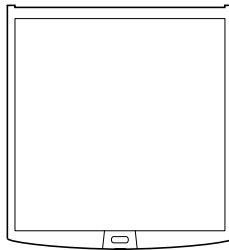

Figure 10: Sealing the protective cover CL-LAD.FD011

The grip handle of the protective cover is provided with holes that can be used in any mounting position. You can fit a wire or similar material through these holes in order to seal the cover. If the wire is provided with a lead seal, the cover is sealed. The cover can then only be opened by breaking the seal or the wire.

Mounting the display module (front mounting)



The CL-LAD.FD001 or CL-LAD.FD011 protective cover must be mounted beforehand!

- ▶ Drill and punch out two 22.5 mm diameter holes in the front plate. The diameter is the same as is normally required for control circuit devices.



Observe the following technical requirements:

- The hole spacing is 30 mm.
- The maximum thickness of the front plate for mounting the remote display connection module must not exceed 6 mm.
- Ensure that the minimum clearances for the remote display connection module (→ page 13) are observed.
- In order to ensure protection to IP 65, the surface of the mounting front must be even and smooth.

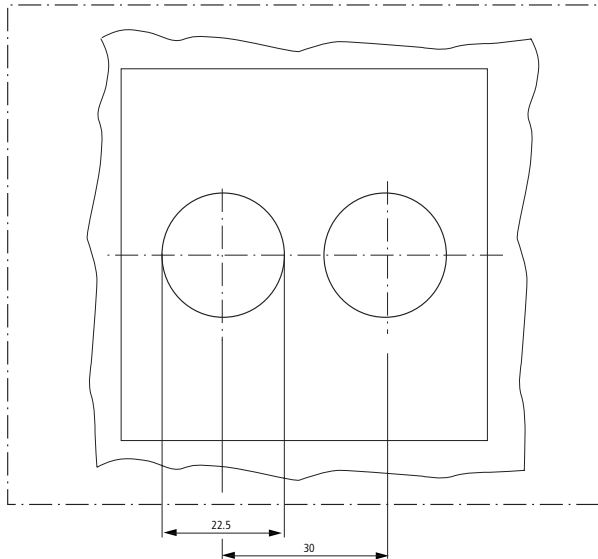

Figure 11: Drill holes CL-LDD...

- ▶ Fit the display module in the fixing holes provided.

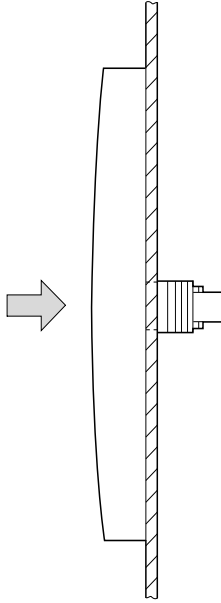

Figure 12: Mounting display module

- ▶ Screw on the display module as shown in (→ figure 13).

The tightening torque must be between 1.2 and 2 Nm



Ensure that the correct torque is used. If the tightening torque is too low or high, this may impair the seal.

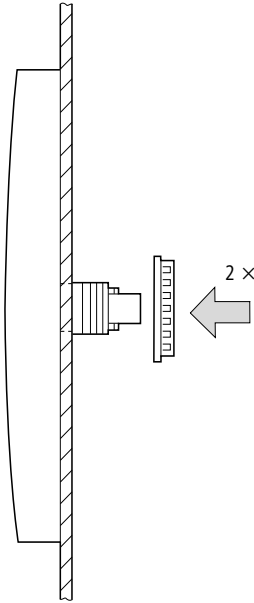

Figure 13: Screw fastening the display module

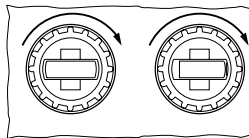

Figure 14: Rear of mounted display module

Demounting the display module (front mounting)

- ▶ Unscrew the fixing element and remove the display module.

Mounting remote display connection module

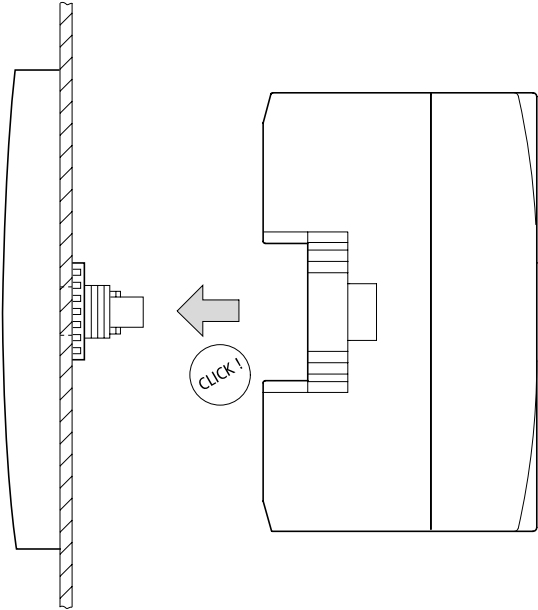

Figure 15: Mounting remote display connection module

Demounting remote display connection module

Use a screwdriver with a 100 x 3.5 mm slot width.

- ▶ Insert the screwdriver into the lug of the fixing shaft catch **1**.
- ▶ Lever out the slide catch **2**.
- ▶ Pull out the remote display connection module from the fixing shafts **3**.

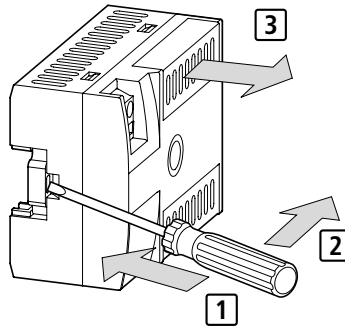

Figure 16: Releasing the fixing shaft

Connections

Terminals

The CL-LDC.S... is fitted with cage clamp terminals for connecting the power supply and the connection cable to the serial interface.

Tool for cage clamp terminals

Slot-head screwdriver, width 3.5 mm x 0.6 mm.

Connection cross-sections of the cage clamp terminal cables

- Power supply terminal: 0.08 to 2.5 mm² (AWG 28 – 12)
- Interface terminal
0.14 to 0.5 mm² (AWG 26 – 20)

Connecting the power supply



The required connection data for the CL-LDC.S... are provided in the section "Technical data", Page 38.

DC power supply CL-LDC.SDC2

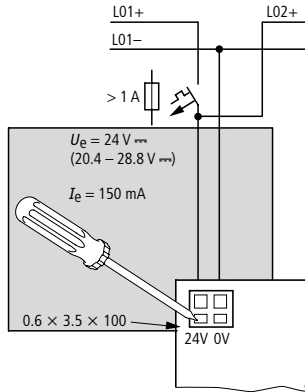

Figure 17: Supply voltage



The CL-LDC.S... is protected against reverse polarity. Ensure the correct polarity of the terminals to ensure that the CL-LDC.S... functions correctly.

Cable protection

Provide cable protection (F1) of at least 1 A (slow) on the CL-LDC.S...



When the CL-LDC.S... is switched on for the first time, its power supply circuit behaves like a capacitor. The switching device and the supply device for switching on the power supply must be designed for this, i.e. no Reed relay contacts, no proximity switches.

With the power supply ensure that the response threshold for the short-circuit current is higher than the inrush current of the CL-LDC.S....

Connecting connection cable

The CL-LDC.S... has a serial interface. This is used for point-to-point communication between the CL-LDC.S... and a CL-LSR/CL-LST, a CL-LMR/CL-LMT or a CL-LDC.L..., provided that no PC is connected to these devices.

Selecting suitable connection cable

Different connection cables are required depending on which device is connected to the CL-LDC.S...:

Table 2: Selecting connection cable

CL-LDC.S... connect with...	Connection cable
CL-LSR/CL-LST	CL-LAD.TK007
CL-LMR/CL-LMT	
CL-LDC.L...	CL-LAD.TK005

The CL-LAD.TK007/CL-LAD.TK005 connection cables are 5 m long.



In order to ensure correct EMC, the CL-LAD.TK.007 and CL-LAD.TK.005 connection cables must not be lengthened.

Connecting connection cable

- ▶ Remove the interface cover carefully. **1**.
- ▶ Use a screwdriver to press down the recess next to the terminal **2** and connect the wires of the connection cable to the terminals **3** in the order stated. Proceed accordingly in the reverse order to remove the connection cable **4**.
- ▶ Refit the interface cover. **5**

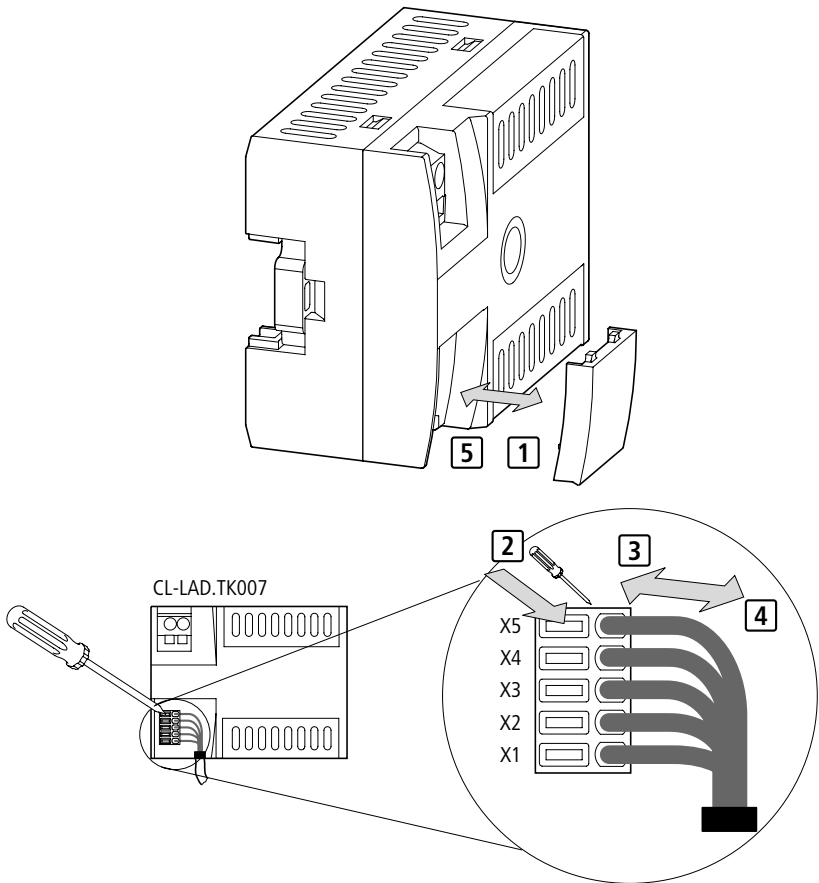

Figure 18: Connecting connection cable

X1 = grey, X2 = brown, X3 = yellow, X4 = white, X5 = green

► Fit the connection cable plug into the CL basic unit.

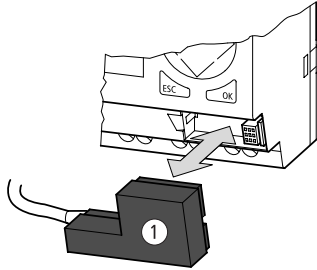

Figure 19: Fitting the connection plug ① to the CL basic unit
left side: CL-LDC.L..., right side: CL-LSR/CL-LST, CL-LMR/CL-LMT

3 Commissioning

Switching on

Before switching on check that the power supply and the connection cable are properly connected:

- Terminal +24 V: voltage +24 V
- Terminal 0 V: voltage 0 V

If you have already integrated devices into a system, secure any parts of the system connected to the working area to prevent access and ensure that no-one can be injured if, for example, motors start up unexpectedly.



Caution!

The remote display allows you to operate a device that may be positioned far from your actual location. All access rights that you would also require "locally" are granted to you. However, it is not always possible to obtain a view of the situation "locally". Use of this operating mode and the execution of any changes to device settings should therefore only be carried out with the utmost caution.

You can also carry out settings locally on the device whilst you are operating a device remotely via the keypad. In this case, the local operation on the device is always faster than the remote operation in Terminal mode. Bear in mind that this may lead to conflicts that may trigger faults or unforeseen events.



A remote display makes its display and keypad available to the connected device. Only data for the display and the status of the buttons is sent via the connection. This ensures that the local data of the connected device is not destroyed in the event of a communication fault.

Initial commissioning

When you switch on the remote display for the first time, you will be asked to select the menu language.

- ▶ Select the required menu language and confirm the setting by pressing the OK button.
- ▶ Press ESC to exit language selection.



If you do not set the language, the remote display will display this menu every time you switch on and wait for you to select a language.

You can change the language setting at a later time as required (→ section “Setting the menu language”, Page 34).

```
Connection
  establishme
nt
in progress...
```

If the device was switched on for the first time, the remote display will try to establish a connection with the default settings to a connected device. The status and text display of the remotely operated device is displayed as soon as the connection can be established.

4 Device application

You can use the remote display for a point-to-point connection or in the CL-NET network. CL-NET operation is only possible in combination with the CL-LDC.LN.. display base module.

Point-to-point connection

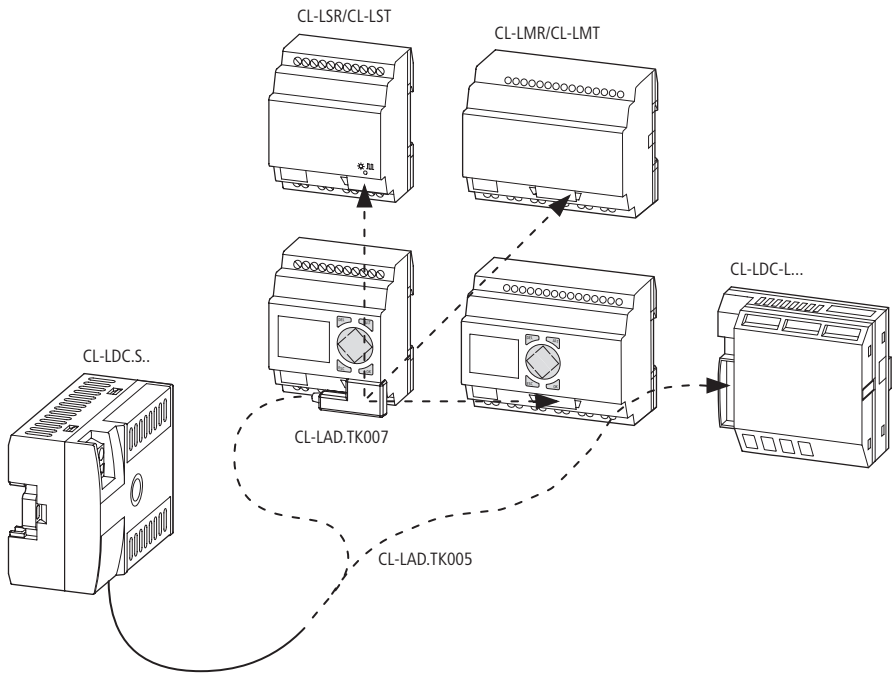
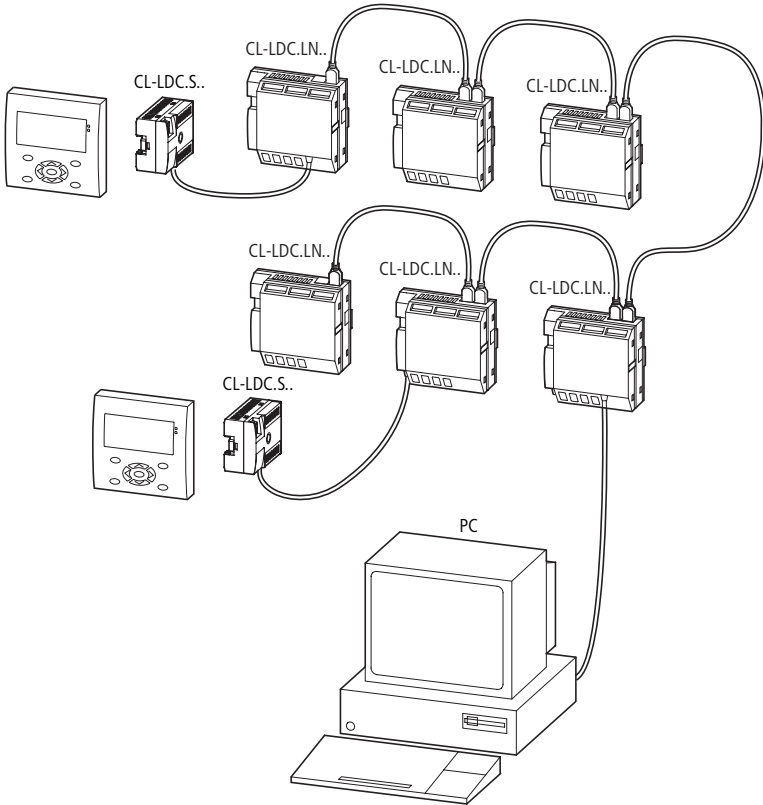

Figure 20: Possible point-to-point connection via the serial interface

CL-NET operation



Communication via CL-SOFT is no longer possible if a network station (CL-LDC.LN...) is connected to a PC and is being accessed by a CL-LDC.S... This also applies to program uploads and downloads.

To enable communication simply set a different station ID in the main menu of the CL-LDC.S... in the COM menu (→ page 11).



Avoid data conflicts between the connected devices!

Connection faulty

If the connection is faulty or interrupted, the CL-LDC.S... will display the message "Connection establishment in progress..." continuously. However, this message may also be due to an incorrect COM setting (→ section "Main menu", Page 11).



```
Connection
establishment
in progress...
```

Graphic mode on the remotely operated device

If the remote display is connected with another display system and if this remotely operated display system is in graphic mode, this graphic will not be shown on the remote display. You can terminate graphic mode from the remote display by pressing ALT + ESC. This can also be achieved by pressing the "*" button on the remotely operated display system provided that another function was not assigned to this button (→ section "Special function", Page 12).

5 Settings

The following settings to the connected basic unit can be made via the remote display.

Station selection

Pressing the "*" button activates the main menu of the remote display system.

- ▶ Press the * button.

```
COM . . .
MENU LANGUAGE . . .
LIGHTING: 60%
CONTRAST: +2
```

The main menu will appear.

- ▶ Select the COM menu item and press the **OK** button.

```
STATION ID: 0
BAUDRATE: 9600B
```

The Station ID menu will appear.

- ▶ Press the **OK** button and select the station number with ^ and v.
- ▶ Confirm with **OK**.



Station ID 0 is always assigned to the device directly connected via the interface. All other station IDs are assigned to the NET-IDs of the individual NET stations in a CL-NET.

```
STATION ID: 0
BAUDRATE: 9600B
```

- ▶ Press the **OK** button and select the baud rate using ^ and v.
- ▶ Confirm with **OK**.



The transfer rate for CL-LSR/CL-LSM and CL-LMR/CL-LMT is restricted to 9600 baud. The transfer rate for CL-LDC.L... can be set to a maximum baud rate of 19200 baud.

```

COM...
MENU LANGUAGE...
LIGHTING: 60%
CONTRAST: +2

```

► Exit the COM menu with **ESC**.

You can leave the main menu at any time by pressing the "*" button.

```

Connection
  establishme
nt
in progress...

```

When you exit the main menu, the CL-LDC.S... will try to establish connection to the selected device. The status and text display of the remotely operated device is displayed as soon as the connection can be established.

Setting the menu language

If the main menu of the remote display is not active, press the "*" button to enter the menu.

```

COM...
MENU LANGUAGE...
LIGHTING: 60%
CONTRAST: +2

```

► Use the ^ and v buttons to select the Menu language menu item.

► Confirm with **OK**.

```

ENGLISH      ↑
DEUTSCH      ✓
FRANCAIS
ESPANOL      ↓

```

► Use the cursor buttons ^ or v to select the language required.

- English
- German
- French
- Spanish
- Italian
- Portuguese
- Dutch
- Swedish
- Polish
- Turkish
- Hungarian
- Czech
- Russian

► Press **OK** to confirm your choice and press **ESC** to exit the menu.

You can leave the main menu at any time by pressing the "*" button.

Changing the lighting

If the main menu of the remote display is not active, press the "*" button to enter the menu.

```
COM...
MENU LANGUAGE...
LIGHTING: 60
CONTRAST: +2
```

► Use the ^ and v buttons to select the Lighting menu item. The cursor moves to the percentage value of the lighting.



When Selection mode is active, the cursor appears as a black flashing rectangle. Pressing **OK** will activate Edit mode in which the cursor will disappear and the number will flash. In Edit mode, use the ^ and v buttons to change the value. The changes are displayed immediately.

► Press **OK**.

```
COM...
MENU LANGUAGE...
LIGHTING: 70%
CONTRAST: +2
```

Now change the value in 10 % steps with the ^ and v buttons.

► Press the ^ or v buttons to change the value.

► Press **OK** or **ESC** to exit Edit mode

If Selection mode is active, you can exit the main menu at any time by pressing the "*" button.

Changing the contrast

If the main menu of the remote display is not active, press the "*" button to enter the menu.

```

COM...
MENU LANGUAGE...
LIGHTING: 70%
CONTRAST : +2

```

► Use the ^ and v buttons to select the Contrast menu item.

The cursor moves to the percentage value of the contrast.



When Selection mode is active, the cursor appears as black flashing rectangle. Pressing OK will activate Edit mode in which the cursor will disappear and the number will flash. In Edit mode, use the ^ and v to change the value. The changes are displayed immediately.

► Confirm with OK.

```

COM...
MENU LANGUAGE...
LIGHTING: 70%
CONTRAST : +1

```

Use the ^ and v buttons to change the value between -2 and +2 in increments of 1.

► Press the ^ or v buttons to change the value.

► Press **OK** or **ESC** to exit Edit mode

If Selection mode is active, you can exit the main menu at any time by pressing the "*" button.

6 Appendix

Dimensions

Display module CL-LDD...

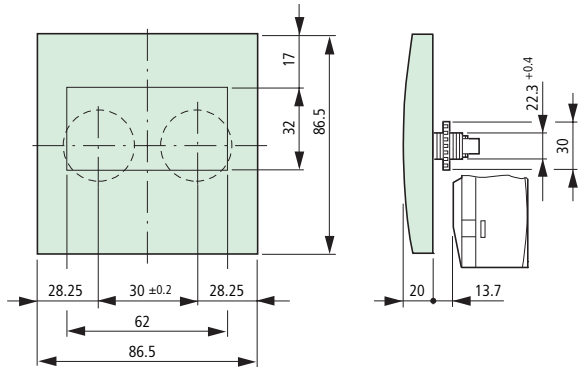

Protective cover CL-LAD.FD001

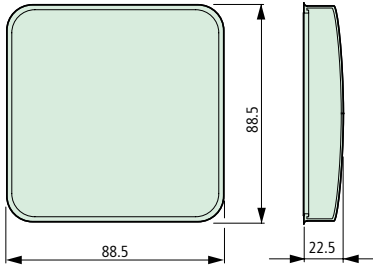

Protective cover CL-LAD.FD011

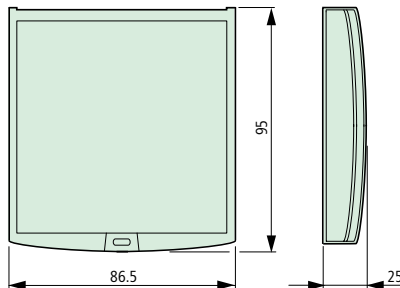

Remote display connection module CL-LDC.S...

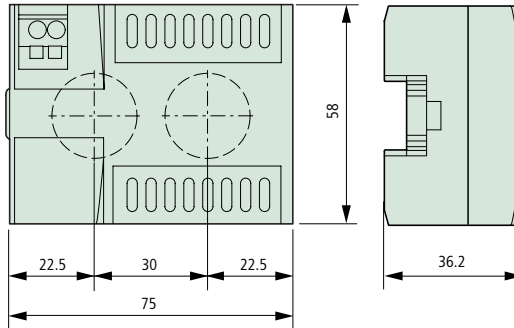

Technical data	General ambient conditions	
Climatic conditions (damp heat constant to IEC 60068-2-78; cyclical to IEC 60068-2-30)(cold to IEC 60068-2-1, heat to IEC 60068-2-2)		
Ambient temperature Installed horizontally/vertically	°C, (°F)	-25 to 55, (-13 to 131)
Condensation		Prevent condensation with suitable measures
Display legibility	°C, (°F)	-5 to 50, (23 to 122)
Storage/transport temperature	°C, (°F)	-40 to 70, (-40 to 158)
Relative humidity (IEC 60068-2-30), non-condensing	%	5 to 95
Air pressure (operation)	hPa	795 to 1080

Mechanical ambient conditions			
Pollution degree			
Remote display connection module			2
Display module			3
Degree of protection (EN 50178, IEC 60529, VBG4)			
Remote display connection module			IP20
Display module			IP65
Display module with protective cover, CL-LAD.FD011			IP65
Display module with protective cover, CL-LAD.FD001			IP65, NEMA 4x
Oscillations (IEC 60068-2-6)			
Constant amplitude 0.15 mm	Hz		10 to 57
Constant acceleration 2 g	Hz		57 to 150
Shock (IEC 60068-2-27) half-sinusoidal 15 g/11 ms	Shocks		18
Drop (IEC 60068-2-31)	Drop height	mm	50
Free fall, when packed (IEC 60068-2-32)		m	1
Electromagnetic compatibility (EMC)			
Electrostatic discharge (ESD), (IEC/EN 61000-4-2, severity level 3)			
Air discharge		kV	8
Contact discharge		kV	6
Electromagnetic fields (RFI), (IEC/EN 61000-4-3)		V/m	10
Radio interference suppression (EN 55011, EN 55022), limit class			B
Fast transient burst (IEC/EN 61000-4-4, severity level 3)			
Power cables		kV	2
Signal cables		kV	2
High energy pulses (Surge) MFD (IEC/EN 61000-4-5, severity level 2), power cable symmetrical		kV	1
Line-conducted interference (IEC/EN 61000-4-6)		V	10

Insulation resistance		
Overvoltage category		II
Clearance and creepage distances		EN 50178, UL 508, CSA C22.2, No 142
Insulation resistance		EN 50178
Tools and cable cross-sections		
Power supply terminal		
Solid and flexible with ferrule, minimum to maximum	mm ²	0.08 to 2.5
	AWG	28 to 12
Interface terminal		
Flexible, tin-coated, minimum to maximum	mm ²	0.14 to 0.5
	AWG	26 to 20
Slot-head screwdriver, width	mm	3.5 × 0.5
	inch	0.14 × 0.02

Display module CL-LDD...

Front dimensions W × H × D		
With buttons	mm	86.5 × 86.5 × 21.5
	inches	3.41 × 3.41 × 0.85
Without buttons	mm	86.5 × 86.5 × 20
	inches	3.41 × 3.41 × 0.79
Overall dimensions with fixing shaft W × H × D		
With buttons	mm	86.5 × 86.5 × 43
	inches	3.41 × 3.41 × 1.69
Thickness of fixing wall (minimum; maximum)	mm	1; 6
	inches	0.04; 0.24
Weight	g	130
	lb	0.287

Mounting		2 22.5 mm (0.886 in) holes Display fastened with two fixing rings
Maximum tightening torque of the fixing rings [Nm]		1.2 to 2
Power supply		via remote display connection module CL-LDC.S...
LCD display		
Type		Graphic/monochrome
Visible area W x H	mm	62 x 33
Size of pixels	mm	0.4 x 0.4
Number of pixels (W x H)		132 x 64
Spacing (pixel centre to pixel centre)	mm	0.42
LCD backlight		Yes
Backlight colour		Yellow/green
The backlight can be used and programmed in visualization applications		Yes
LEDs		
Number of LEDs		2
Operating buttons		
Quantity		9
Pushbutton illumination (LED)		
Quantity		5
Colour		green

Protective cover CL-LAD.FD001

Dimensions W x H x D	mm	88 × 88 × 25
	inches	3.46 × 3.46 × 0.98
Weight	g	25
	lb	0.055
Mounting		Fitted over the display module (with Titan front ring)

Protective cover CL-LAD.FD011

Dimensions W x H x D	mm	86.5 × 94 × 25
	inches	3.41 × 3.41 × 0.98
Weight	g	36
	lb	0.079
Mounting		Fitted over the display module (without Titan front ring)

Remote display connection module CL-LDC.S...

Dimensions W x H x D	mm	75 × 58 × 36.2
	inches	2.95 × 2.28 × 1.43
Weight	g	164
	lb	0.362
Mounting		Plug-fitted to the display fixing shaft
Power supply		
Rated voltage		
Nominal value	V DC, (%)	24, (+20, -15)
Permissible range	V DC	20.4 bis 28.8
Residual ripple	%	≅ 5
Input current		
at 24 V DC, CL-LDC.S..., CL-LDD..., typical	mA	150
Voltage dips, IEC/EN 61131-2	ms	10
Heat dissipation		
at 24 V DC, CL-LDC.S..., CL-LDD..., typical	W	3.6

Index

B	Baud rate	11
C	Cable protection	23
	Commissioning	27
	Communication via CL-SOFT	30
	Connecting connection cable	24
	Connecting power supply	23
	Connection faulty	31
	Connection plug	26
	Contrast	36
D	Dimensions	37
	Drill holes	18
G	Graphic mode	12, 31
K	Keypad	8, 10
L	Language setting	28
	Lighting	35
M	Menu language	28
	Minimum clearances, to display module	13
	Mounting	
	display module	18
	protective cover	15
	remote display connection module	21
N	Network operation	6
P	Point-to-point connection	29
	Protective cover	
	mounting	15
	sealing	17

R	Range of applications	5
----------	-----------------------------	---

S	Sealing	
	protective cover	17
	Select main menu	11
	select system menu	11
	Serial interface	9
	Set value	12
	Setting the menu language	34
	Settings	33
	Station ID	11
	Station selection	33
	Status display	11, 12
	Supply voltage	9
	Switching on	27
	System overview	7

T	Task	6
	Terminals	22
	Transfer rate	33



ABB STOTZ-KONTAKT GmbH

Postfach 10 16 80, 69006 Heidelberg
Eppelheimer Straße 82, 69123 Heidelberg
GERMANY

www.abb.com/lowvoltage → Electronic Relays