

Comando solenoide sovrapposto
Superimposed solenoid operator
Solenoidsteuerung übereinanderliegend
Commande solénoïde superposé
Comando solenoide sobrepuesto

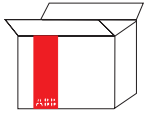

Tensione nominale di impiego Rated service voltage Bemessungsbetriebsspannung Tension assignée de service Tensión nominal de servicio	cc 48-60-110-220v 50 Hz 110-220 v	Tempo di manovra Operation time Schaltzeit Temps de manoeuvre Tiempo de maniobra	≤ 0.1 s
Potenza nominale Rated power Nennleistung Puissance nominale Potencia nominal	cc 700-900 W 50 Hz 2300-2500VA	Percentuali di funzionamento Operating percentages ED % Pourcentages de fonctionnement Porcentaje de funcionamiento	IEC 947-2

S1

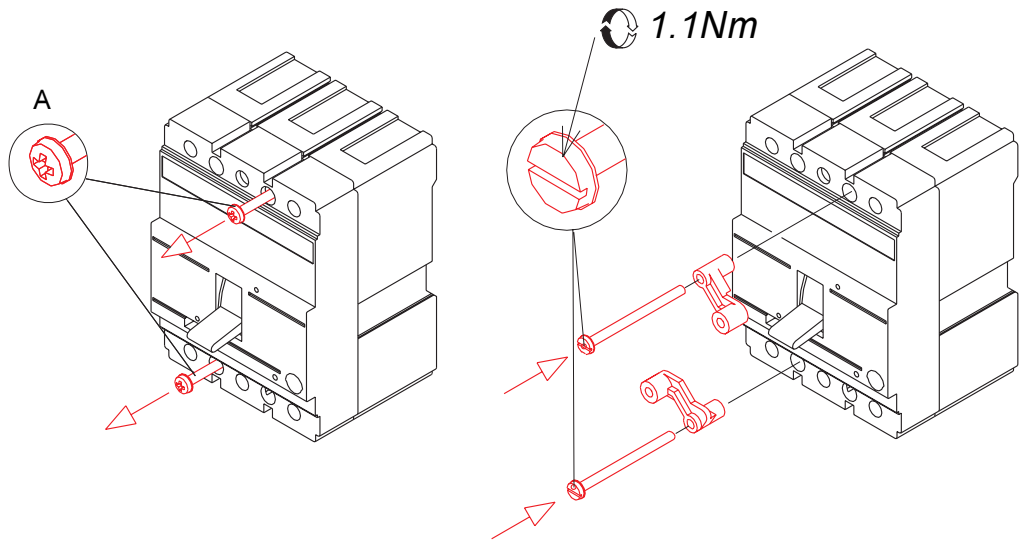
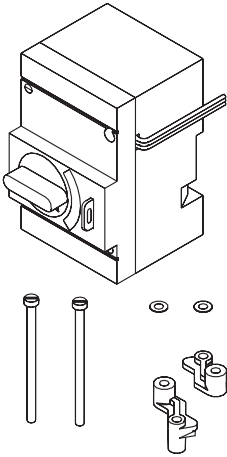

A

B

S2

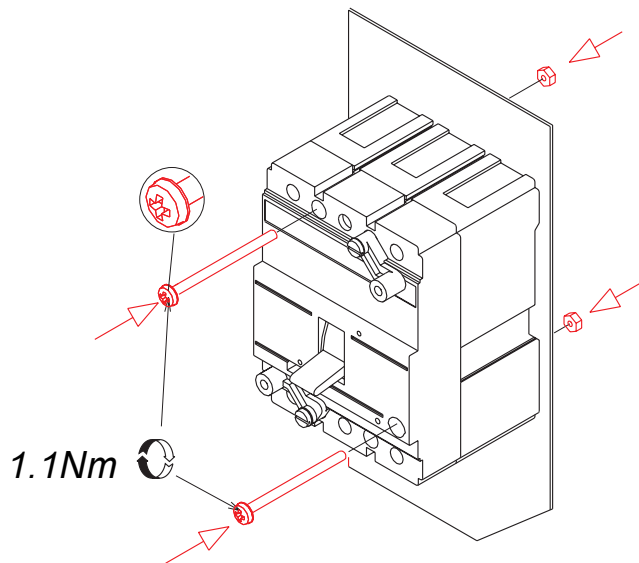
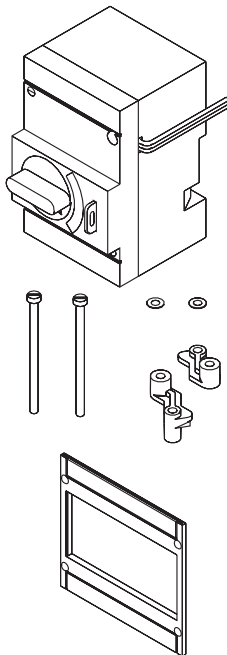

C

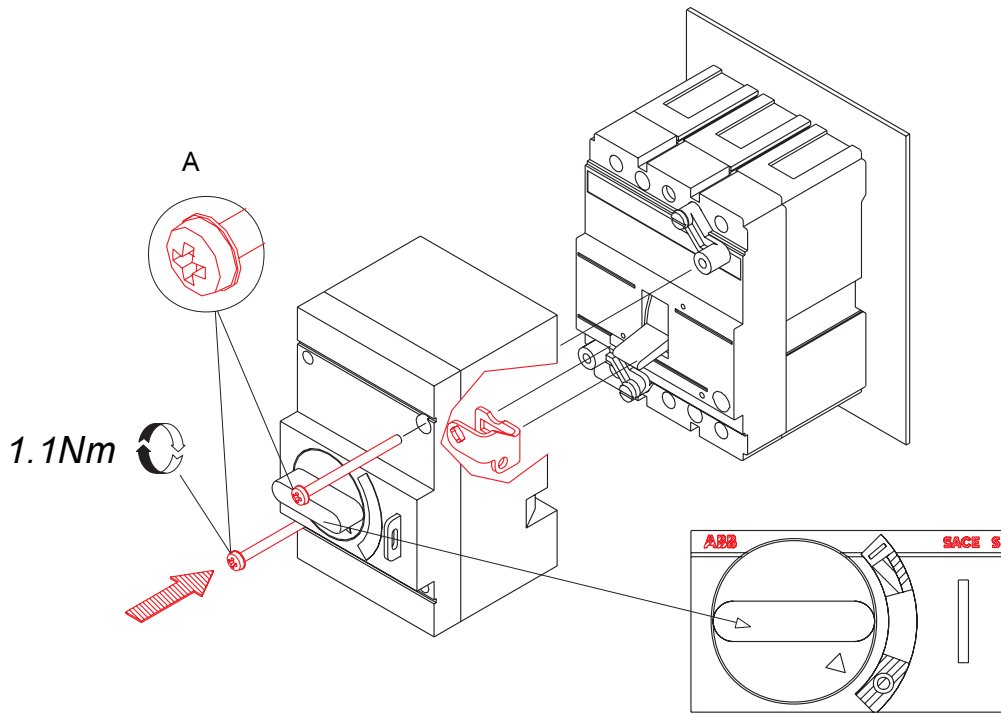

D

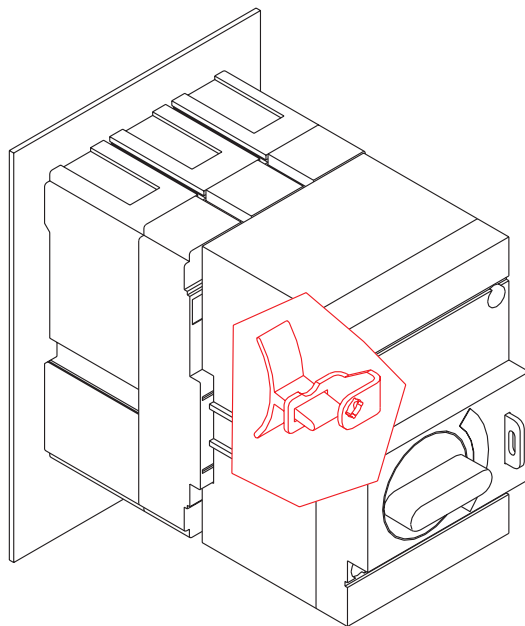

E

-Verificare con alcune manovre manuali che l'indice si posizioni correttamente (I - 0).

-Make several manual movements to check that the index goes to the correct position(I - 0).

-Mit einigen manuellen Schaltungen überprüfen, ob sich der Zeiger in die richtige Stellung begibt (I - 0).

-Vérifier avec quelques manoeuvres manuelles que l'aiguille se positionne correctement (I - 0).

-Verificar con algunas maniobras manuales que el índice se coloque correctamente (I - 0).

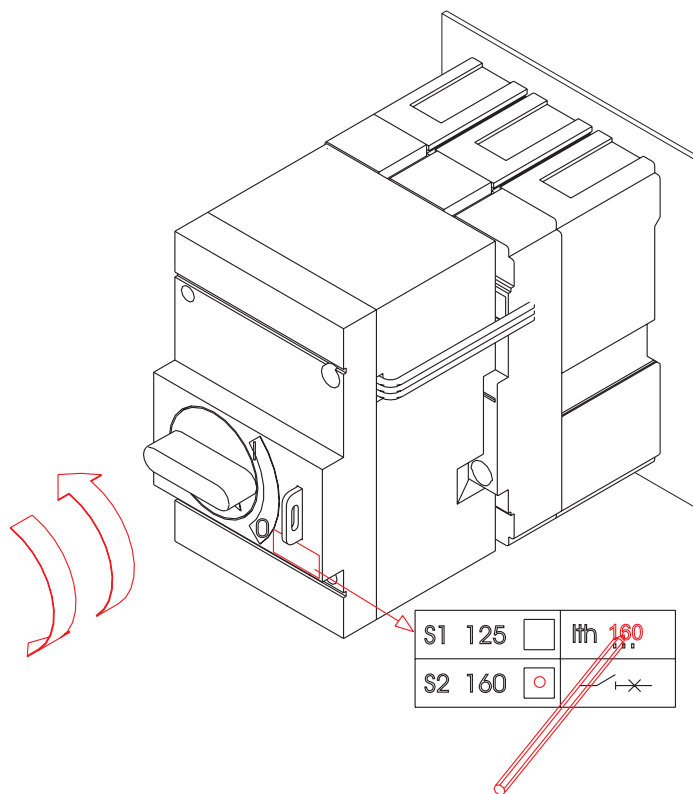

F

-Blocco a lucchetti solo in aperto.

-Padlock block open only.

-Schloßverriegelung nur im geöffneten Zustand.

-Verrouillage avec cadenas uniquement sur ouvert.

-Bloqueo con candados solo en abierto.

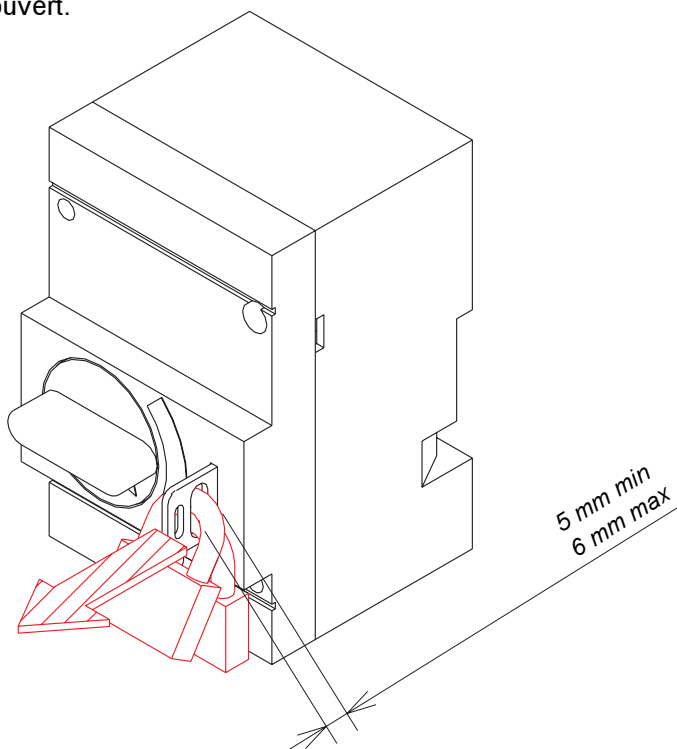

G

- Foratura porta della cella.
- Compartment door drilling.
- Bohrung Tür.
- Perçage porte.
- Perforación puerta.

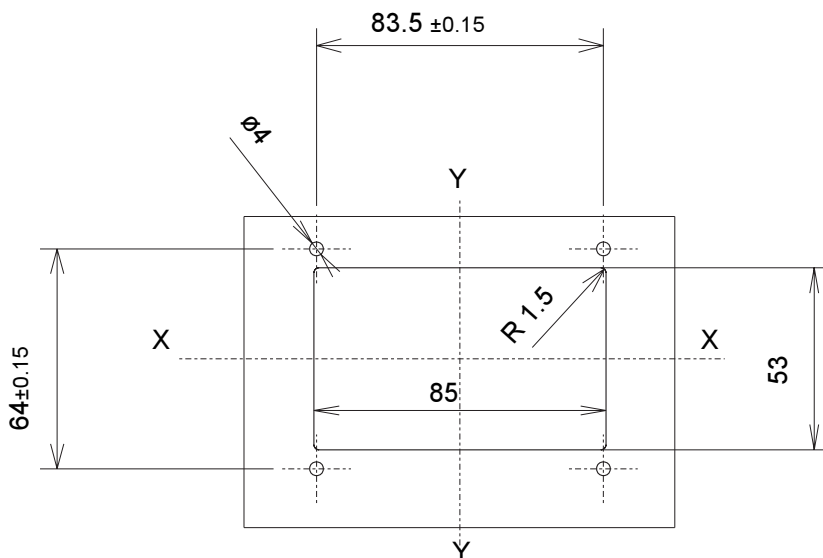

H

Legenda:

- SC= pulsante o contatto per la chiusura dell'interruttore*
- SO= pulsante o contatto per l'apertura dell'interruttore*
- X3= connettori per i circuiti ausiliari
- YC-Y02= bobina di manovra
- S1-S2= contatto di posizione
- S3= contatto di sicurezza azionato dal blocco lucchetti
- *Il comando deve avere una durata non inferiore a 100 ms.

Key:

- SC= push-button or contact for closing the switch*
- SO= push-button or contact for opening the switch*
- X3= auxiliary circuit connector
- YC-Y02= movement coil
- S1-S2= position contact
- S3= safety contact activated by the padlock block
- *The operating mechanism must have a time of not less than 100 ms.

Legende:

- SC= Drucktaste oder Kontakt zum Schließen des Schalters*
- SO= Drucktaste oder Kontakt zum Öffnen des Schalters*
- X3= Anschluß für Hilfsstromkreise
- YC-Y02= Schaltspule
- S1-S2= Positionsmeldeswitcher
- S3= Von der Schloßverriegelung betätigter Sicherheitsschalter
- * Die Dauer des Befehls nicht nuter 100 ms liegen.

Légende:

- SC= Bouton-poussoir ou contact pour la fermeture de l'interrupteur*
- SO= Bouton-poussoir ou contact pour l'ouverture de l'interrupteur*
- X3= Connecteur pour circuits auxiliaires
- YC-Y02= Bobine de manoeuvre
- S1-S2= Contact de position
- S3= Contact de sécurité actionné par le verrouillage cadenas
- *La commande doit avoir une durée non inférieure à 100 ms.

Leyenda:

- SC= Botón o contacto para cerrar el interruptor*
- SO= Botón o contacto para abrir el interruptor*
- X3= Conector para circuitos auxiliares
- YC-Y02= Bobina de maniobra
- S1-S2= Contacto de posición
- S3= Contacto de seguridad accionado por el bloqueo de los candanas
- * El mando debe poseer una duración no inferior a 100 ms.

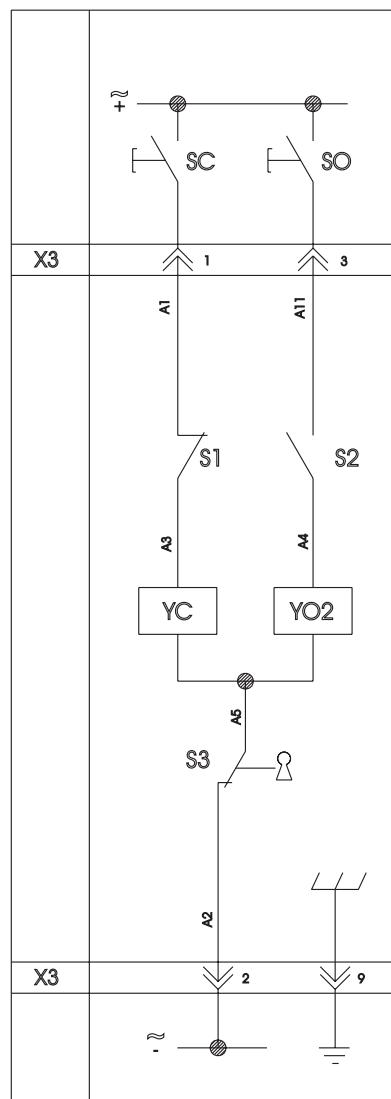

I