

Instruction manual

PR223EF

Modbus™ System Interface

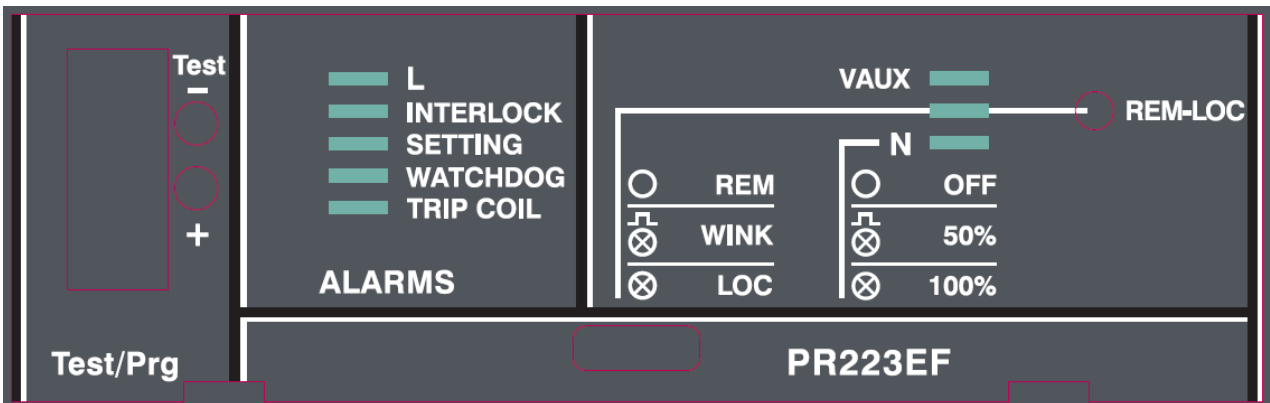

Author Autore	LB-DTA	L3793	Title Titolo	PR223EF Modbus™ System Interface	ENG
ABB			Doc. No N. Doc.	1SDH000566R0001	Tot. Pag. 1/55

1. GENERAL.....	6
1.1 APPLICABILITY	6
1.1.1 SW version	6
1.2 APPLICABLE DOCUMENTS	6
ACRONYMS AND DEFINITIONS	7
1.2.1 Acronyms.....	7
1.2.2 Definitions.....	8
2. INTRODUCTION.....	10
2.1 MODBUS PROTOCOL AND MAP ORGANIZATION	10
2.1.1 Communication parameters	10
2.1.2 Device RTU Framing	10
2.1.3 Response Timeout	12
2.1.4 Reception Checks	12
2.1.5 Function Codes	12
2.1.6 Data Addressing (Map organization)	14
2.1.7 Data Field.....	16
2.1.8 Exception Responses	17
2.1.9 Broadcast messaging	18
2.2 INSTALLATION AND CONFIGURATION	19
3. START-UP BEHAVIOUR.....	20
4. OPERATING MODE.....	21
4.1 LOCAL OPERATING MODE	21
4.2 REMOTE OPERATING MODE.....	21
5. CONFIGURATION PARAMETERS PROGRAMMING MODEL.....	22
5.1 PROGRAMMING MODEL.....	22
5.1.1 Programming Model.....	23
6. COMMANDS.....	24
6.1 COMMAND CATEGORIES	24
6.1.1 Wink Command.....	24
6.1.2 Trip Reset	24
6.1.3 CB Reset.....	24
6.1.4 Remote CB Close command after Trip Command Fail.....	25
6.1.5 CB commands inhibition	25
6.2 COMMANDS MANAGEMENT	25
6.2.1 Commands completion.....	25
6.2.2 Commands inhibition	26
6.3 LOCAL COMMANDS MANAGEMENT.....	27
6.3.1 CB Open.....	27
6.3.2 CB Close	27
6.3.3 CB Reset.....	27
7. HUMAN MACHINE INTERFACE / LOCAL USER INTERFACE.....	28
7.1 LEDS	28
8. MODBUS LOGICAL MAP	29
8.1 DATA ORGANIZATION	29
8.1.1 Byte	29
8.1.2 Word.....	29
8.1.3 Double word.....	29
8.2 BIT FIELD ORGANIZATION	29

Author Autore	LB-DTA	L3793	Title Titolo	PR223EF Modbus™ System Interface	ENG
ABB			Doc. No N. Doc.	1SDH000566R0001	Tot. Pag.
					2/55

8.3	REGISTERS	30
8.3.1	Buffer “Communication statistics”	31
8.3.2	Buffer “Process Statistics”	32
8.3.3	Buffer “Reports”	33
8.3.4	Buffer “Program fail code”	37
8.3.5	Buffer “Currents”	38
8.3.6	Buffer “Voltages”	38
8.3.7	Buffer “Other measurements”	39
8.3.8	Buffer “Trip currents”	40
8.3.9	Buffer “Trip reports”	41
8.3.10	Buffer “Parameters”	42
8.3.11	Buffer “Device Serial Number”	46
8.3.12	Buffer “Communication parameters”	46
8.3.13	Buffer “System disconnection timeout”	46
8.3.14	Buffer “Nominal current”	47
8.3.15	Buffer “CB type”	47
8.3.16	Buffer “SW version”	48
8.3.17	Buffer “TAG name & User data”	49
8.3.18	Buffer “Historical trips”	50
8.4	COMMANDS	52
8.4.1	Buffer “CB Open” command	52
8.4.2	Buffer “CB Close” command	52
8.4.3	Buffer “CB Reset” command	52
8.4.4	Buffer “Start programming session” command	53
8.4.5	Buffer “Abort programming session” command	53
8.4.6	Buffer “Stop programming session” command	53
8.4.7	Buffer “Trip Reset” command	53
8.4.8	Buffer “Wink” command	54
8.4.9	Buffer “Trip history acquisition” command	54
8.4.10	Buffer “Reset communication statistics” command	54
9.	REVISION HISTORY	55
9.1	REVISION A – 2006/02/24	55

Author Autore	LB-DTA		L3793	Title Titolo	PR223EF Modbus™ System Interface	ENG
ABB				Doc. No N. Doc.	1SDH000566R0001	Tot. Pag. 3/55

Index of figures

Pag.

FIGURE 1. REMOTE PROGRAMMING MODEL STATE CHART 23
 FIGURE 2. "WINK COMMAND" FSM..... 24
 FIGURE 3. LED "REM/LOC/WINK" FSM 28

				Title		ENG
Author Autore	LB-DTA	L3793		Titolo	PR223EF Modbus™ System Interface	
ABB				Doc. No N. Doc.	1SDH000566R0001	Tot. Pag.
						4/55

TABLE 1. SERIAL PARAMETERS.....	10
TABLE 2. MODBUS MESSAGE	10
TABLE 3. RESPONSE TIMEOUT	12
TABLE 4. PR223EF FUNCTION CODES	12
TABLE 5. DIAGNOSTIC QUERY DATA FIELD STRUCTURE.....	13
TABLE 6. REPORT SLAVE ID RESPONSE DATA FIELD STRUCTURE	13
TABLE 7. SLAVE ID	13
TABLE 8. MODBUS LOGICAL MEMORY MAP	15
TABLE 9. QUERY DATA FIELD STRUCTURE.....	16
TABLE 10. READ FUNCTION RESPONSE DATA FIELD STRUCTURE.....	16
TABLE 11. MULTIPLE ITEMS WRITE FUNCTION RESPONSE DATA FIELD STRUCTURE	17
TABLE 12. EXCEPTION RESPONSE ERROR CODES.....	17
TABLE 13. PR223EF EXCEPTION RESPONSES USE.....	18
TABLE 14. BROADCAST MESSAGES	18
TABLE 15. COMMUNICATION PARAMETERS.....	19
TABLE 16. START-UP TIME.....	20
TABLE 17. COMMAND RESULTS	25
TABLE 18. CONDITIONS FOR COMMANDS' INHIBITION	26
TABLE 19. LEDS	28
TABLE 20. BIT FIELD ORGANIZATION.....	29
TABLE 21. BUFFER "COMMUNICATION STATISTICS".....	31
TABLE 22. BUFFER "PROCESS STATISTICS"	32
TABLE 23. BUFFER "REPORTS".....	35
TABLE 24. BUFFER "PROGRAM FAIL CODE"	37
TABLE 25. PROGRAM FAIL CODES	37
TABLE 26. BUFFER "CURRENTS"	38
TABLE 27. BUFFER "VOLTAGES"	38
TABLE 28. BUFFER "OTHER MEASUREMENTS"	39
TABLE 29. BUFFER "TRIP CURRENTS"	40
TABLE 30. BUFFER "TRIP REPORTS"	41
TABLE 31. BUFFER "PARAMETERS"	42
TABLE 32. PLANT NOMINAL VOLTAGES	43
TABLE 33. DO CONFIGURATION	44
TABLE 34. PARAMETERS LIMITATION ACCORDING TO CB TYPE/TA SIZE	44
TABLE 35. PARAMETERS DEFAULT VALUES	45
TABLE 36. BUFFER "COMMUNICATION PARAMETERS"	46
TABLE 37. BUFFER "SYSTEM DISCONNECTION TIMEOUT"	46
TABLE 38. BUFFER "NOMINAL CURRENT"	47
TABLE 39. NOMINAL CURRENT ALLOWED VALUES	47
TABLE 40. BUFFER "CB TYPE"	47
TABLE 41. BUFFER "SW VERSION"	48
TABLE 42. BUFFER "TAG NAME & USER DATA"	49
TABLE 43. BUFFER "HISTORICAL TRIP REPORT"	51
TABLE 44. BUFFER "CB OPEN" COMMAND.....	52
TABLE 45. BUFFER "CB CLOSE" COMMAND.....	52
TABLE 46. BUFFER "CB RESET" COMMAND	52
TABLE 47. BUFFER "START PROGRAMMING SESSION" COMMAND.....	53
TABLE 48. BUFFER "ABORT PROGRAMMING SESSION" COMMAND.....	53
TABLE 49. "STOP PROGRAMMING SESSION" COMMAND	53
TABLE 50. BUFFER "TRIP RESET" COMMAND	53
TABLE 51. BUFFER "WINK" COMMAND	54
TABLE 52. BUFFER "TRIP HISTORY ACQUISITION" COMMAND.....	54
TABLE 53. BUFFER "RESET COMMUNICATION STATISTICS" COMMAND.....	54

Author Autore	LB-DTA	L3793	Title Titolo	PR223EF Modbus™ System Interface	ENG
ABB			Doc. No N. Doc.	1SDH000566R0001	Tot. Pag.
					5/55

1. General

This document describes the Modbus interface regarding:

- Network management of the device (installation, configuration, ...).
- Application objects and slave variables.

1.1 Applicability

This document applies to the devices PR223EF.

1.1.1 SW version

This document applies to the device PR223EF with SW version 02.02.

1.2 Applicable Documents

[1] “MODBUS over serial line – Specification & Implementation Guide”, 12/02/2002, v 1.0

Author Autore	LB-DTA		L3793	Title Titolo	PR223EF Modbus™ System Interface	ENG
ABB				Doc. No N. Doc.	1SDH000566R0001	Tot. Pag.
						6/55

Acronyms and Definitions

1.2.1 Acronyms

AI	Analog Input
AO	Analog Output
AUX-E	I²C bus module for acquisition of CB status
CB	Circuit Breaker (MCCB Tmax family)
CP	Configuration Parameter
CT	Current Transformer
DI	Digital Input
DO	Digital Output
ER	Exception Response
ETT	Electronic Trip Test
In	Nominal current
LSb	Least Significant bit
LSB	Least Significant Byte
LSW	Least Significant Word
MOE-E	I²C bus module for CB commands sending and for acquisition of MC temperature
MSb	Most Significant bit
MSB	Most Significant Byte
MSW	Most Significant Word
MTT	Mechanical Trip Test
OR	(Main) Opening Release
SOR	Shunt Opening Release
TC	Trip Coil
TU	Trip Unit (PR223EF)
UVR	Under Voltage Release
Vaux	Auxiliary Supply

Author Autore	LB-DTA		L3793	Title Titolo	PR223EF Modbus™ System Interface	ENG
ABB				Doc. No N. Doc.	1SDH000566R0001	Tot. Pag.
						7/55

1.2.2 Definitions

ALARM: there are two types of alarm:

Alarm Type	Definition
Alarm	It's similar to a status. It will be frozen after a protection trip in the "Trip Reports" structure. A Trip Reset is NOT necessary to reset it. Ex. L Pre-Alarm, S Alarm, ...
Trip	Only a command can reset it, i.e. a new trip alarm won't be signalled until the reset. Ex. L Tripped, S Tripped, ...

TRIP: Trips are reset after a Trip Reset command or CB Reset command.
meaningful part of a Modbus Map section.
It's defined by the Modbus Map of the device.

CB RESET: event (Any Trip) /alarm reset of any information related to the (last) trip.
It changes also the CB status (i.e. the CB goes to OPEN).

DEVICE: protection Unit (i.e. PR223EF)

EVENT: information that signals foreseen device behaviour.
Typically, the producer of an event is the device, while the consumer (who resets it) is the system.
Reset of an event is automatically done after a read operation from the system.

ITEM: analog (register) Modbus data type.

OPERATION: every CB status transition towards OPEN state, regardless from the starting state (TRIPPED or CLOSED).

OTHER TRIPS: sum of CB status transitions towards the TRIPPED state, either from the OPEN or CLOSED starting state, but not caused by the protection.
So they are all the transitions caused by an electronic / mechanical trip test, under voltage release and secondary shunt opening release.

PARAMETER: information that allows configuration of device functionality (e.g. a protection algorithm).

PERSISTENCE: "volatile/non-volatile" attribute concerning information, i.e. the information is/is not still available after a power fail/HW reset/...

PERSISTENCE	Description
Temporary (Default)	Information is NOT still available after a power fail/HW reset/...
Permanent	Information is still available after a power fail/HW reset/...

For example, parameters and trip data have this attribute set to PERMANENT, while states/events/alarms settings are TEMPORARY.

Author Autore	LB-DTA	L3793	Title Titolo	PR223EF Modbus™ System Interface	ENG
ABB			Doc. No N. Doc.	1SDH000566R0001	Tot. Pag. 8/55

- PROTECTION TRIPS:** sum of real protection trips.
 “Real” means ‘not caused by the Test Unit PR010/T.
- PROTECTION UNIT:** PR223EF electronic board that implements protection algorithms
- PROTECTION X TRIPS:** sum of trip of protection X (e.g. L, S, I, G).
- REGISTER:** the least analogue information container (one word = 2 bytes)
- REMOTE SYSTEM:** a device (SCADA) who behaves as Modbus Master on the external bus. It polls the information provided by the device and sends to it commands and parameters.
- STATUS:** information that represents the dynamics of a functionality (e.g. the CB or a protection algorithm). It can be managed (i.e. set/reset) only by the device itself.
- TRIP COMMAND FAIL:** after a protection trip, with relevant opening command to the release, CB stays in CLOSED state. In this case, the device tries to open the CB by starting a back-up procedure. Meanwhile, the device tries also to open the CB using the YO (through the I/O).
- TRIP RESET:** command equal to CB Reset, but it doesn’t change the “real” CB status (i.e. the CB remains TRIPPED).
- (PROCESS) VARIABLE:** information strictly connected to device functionality. Examples are:
- Commands
 - States/events
 - Alarms
 - Measurements
 - Historical/statistical data
 - ...

Author Autore	LB-DTA		L3793	Title Titolo	PR223EF Modbus™ System Interface	ENG
ABB				Doc. No N. Doc.	1SDH000566R0001	Tot. Pag.
						9/55

2. Introduction

The information contained into the device is described according to the Modbus protocol [1].
When the Test Unit is connected, the device stops communicating with the Remote System when:

- It has read the “Events” structure
or
- A time-out has expired.

Test Unit can access the information contained in this document.

2.1 Modbus Protocol and Map Organization

2.1.1 Communication parameters

1. Transmission mode: RTU (2 four bits hexadecimal chars for each byte).
2. Serial parameters:

Start Bit	Data Bits	Parity Bit	Stop Bit
1	8 (LSb first)	1 (even odd none)	1

Table 1. Serial parameters

Please note that transmission mode and serial parameters MUST be the same for all devices on a Modbus network.

3. Baud Rate: [9600 | 19200] bit/s

2.1.2 Device RTU Framing

START	SLAVE ADDRESS	FUNCTION	DATA	CRC CHECK	END
T1 – T2 – T3 – T4	8 bits	8 bits	n * 8 bits	16 bits	T1 – T2 – T3 – T4

Table 2. Modbus message

Up to 64 bytes can be sent.

The allowed inter-character silent interval is been relaxed from “at least 2 characters” to “at least 4 characters” (the same silent interval to recognise the end of a message). This means:

2.1.2.1 Silent interval < 4 char between two characters inside the message

In this case the receiver filters the silent interval and the following characters will be appended to those already received.
The difference from the protocol specification is:

1. Silent interval < 2 char between two characters inside the message

Transmitter

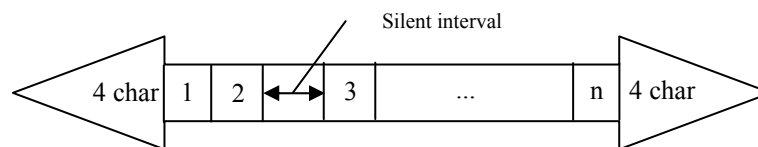

Receiver

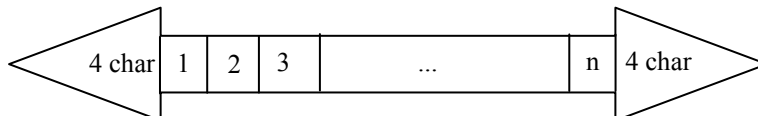

The behaviour is exactly as specified by the protocol.

Author Autore	LB-DTA	L3793	Title Titolo	PR223EF Modbus™ System Interface	ENG
ABB			Doc. No N. Doc.	1SDH000566R0001	Tot. Pag.
					10/55

2. Silent interval ≥ 2 char and < 4 char between two characters inside the message
 The received characters are NOT flushed and the following ones will be appended.

Transmitter

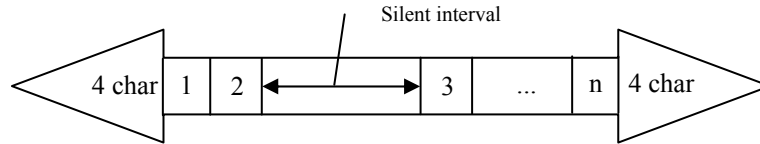

Receiver

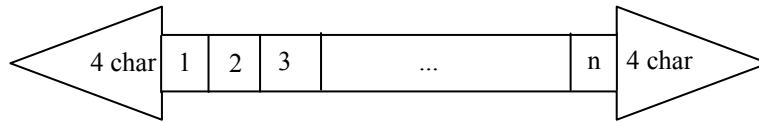

Note that after flushing, the standard protocol specification allows:

- reception of the remaining characters of a partially received message
- reception of a completely new message

The device behaviour **doesn't cover the second case** because it always appends new incoming characters to the previous ones, leading to a CRC error.

So the behaviour is exactly the same if and only if the incoming characters are NOT a new message. In this case the received packet will lead to a CRC error and the CRC error counter will be incremented.

2.1.2.2 Silent interval ≥ 4 char between two characters inside the message

If the message transmission is NOT ended, all the previously received characters are managed as a message because this is exactly the protocol specification regarding the end of a message.

2.1.2.3 New frame before 4 character silent interval at the end of a frame

In this case the receiver filters the silent interval and the following characters (of the new frame) will be appended to those already received (see case 2 of par. 2.1.2.1).

This will lead to a CRC error.

Transmitter

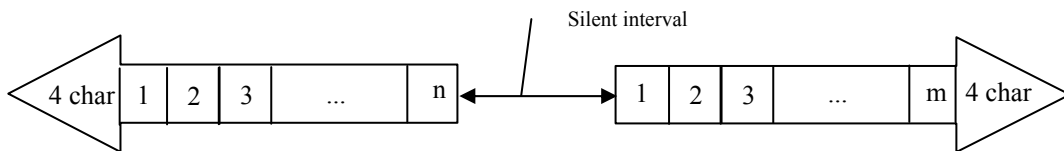

Receiver

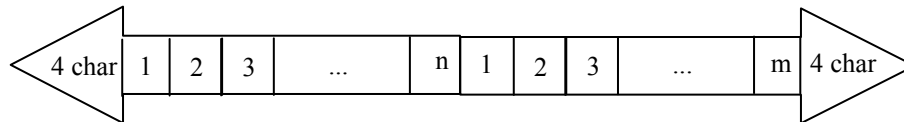

So the CRC error counter will count both the 'real' CRC errors and the inter-character errors.

Author Autore	LB-DTA	L3793	Title Titolo	PR223EF Modbus™ System Interface	ENG
ABB			Doc. No N. Doc.	1SDH000566R0001	Tot. Pag.
					11/55

2.1.3 Response Timeout

The reported timeouts have been measured between the end of the query and the beginning of the transmission of the relevant response. The measurement has been executed with baudrate set to 19200 bit/s and with the device in “normal” status, i.e. NO alarm conditions are satisfied

Query	Min (ms)	Max (ms)	Average (ms)
Read 1 RAM register	2.493	2.925	2.538
Read RAM 24 registers	2.685	3.266	2.910
Read 1 EEPROM register	2.524	3.051	2.594
Read 12 EEPROM registers	2.597	3.305	2.731
Read 1 Flash register	2.528	3.052	2.602
Read 8 Flash registers	2.573	3.281	2.697
Write standard command	2.574	3.280	2.710
Write delayed response command	2.651	12.500	5.400

Table 3. Response Timeout

Please note that the multiple items read has been performed on maximum number of items allowed by the device map:

- for data contained into EEPROM, 12 items
- for data contained into RAM, 24 items
- for data contained into FLASH, 8 items
- for commands with delayed response (i.e. Stop Programming Command)

2.1.4 Reception Checks

After reception, the device performs the following checks:

1. Slave Address
2. CRC
3. Message Length

If any of this information is not correct, the received message is discarded and no response message is sent back to the Master.

2.1.5 Function Codes

According to [1], the following standard functions have to be supported:

Code	HEX Code	Name	Applies to
03	0x03	Read Holding Register	AO
04	0x04	Read Input Register	AI
06	0x06	Preset Single Register	AO
08	0x08	Diagnostic - Sub-function: 0	---
16	0x10	Preset Multiple Registers	AO
17	0x11	Report Slave ID	---

Table 4. PR223EF function codes

All other NOT supported function codes lead to an Exception response “ILLEGAL_FUNCTION”.

These functions can be grouped into two different categories:

1. Data Management functions.
Functions applied to device data into the Modbus Map (codes 03, 04, 06, 16).
2. Network / Device Management functions.
Functions applied to device that can:
 - request / setting general information
 - change the device behaviour / status
 - ...
Function codes 08 and 17 belong to this category.

Author Autore	LB-DTA	L3793	Title Titolo	PR223EF Modbus™ System Interface	ENG
ABB			Doc. No N. Doc.	1SDH000566R0001	Tot. Pag.
					12/55

2.1.5.1 08 (0x08) Diagnostic

This function uses a two-byte sub-function code field in the query to define the type of test to be performed. Most of the diagnostic queries use a two-byte data field to send diagnostic data or control information to the slave.

Sub-function Hi	Sub-function Lo	Data Hi	Data Lo

Table 5. Diagnostic query data field structure

where the only supported sub-function code is:

Sub-function code	HEX code	Name	Description
00	0x00	Return Query Data	The data passed in the information field will be returned to the Master via the addressed Modbus Slave. The entire message returned should be identical to the message transmitted by the Master, field-per-field.

NOTE: the protocol specification on data field is NOT clear. The device allows both a generic field length (i.e. more than two bytes) and a generic value range.

2.1.5.2 17 (0x11) Report Slave ID

A normal response has some fields defined and others device dependent:

Byte Count	Slave ID	Run Indicator Status	Additional Data ...

Table 6. Report Slave ID response data field structure

where:

- **Byte Count** depends on ‘Additional Data’. Its minimum value is 2. In this application its value is 22.
- **Slave ID** is the identifier of the device of a specific manufacturer (i.e. devices from different manufacturers could have the same ‘Slave ID’):

Slave ID	Device
66 = 0x42	PR223EF

Table 7. Slave ID

- **Run Indicator Status** reports the current Slave Run status, fixed to ON (0xFF).
- **Additional Data** contains device dependent information. In this application it is so organized:
 - SW version (2 bytes)
 - Event section address (2 bytes)
 - Device serial number (16 bytes)

Author Autore	LB-DTA	L3793	Title Titolo	PR223EF Modbus™ System Interface	ENG
ABB			Doc. No N. Doc.	1SDH000566R0001	Tot. Pag.
					13/55

2.1.6 Data Addressing (Map organization)

Two different data addressing types are implemented:

1. Standard Modbus addressing
2. ABB SACE addressing (old ABB SACE Modbus Communication Units)

Standard		Data Type	ABB	
Starting Address	Item Address		Starting Address	Item Address
0	1	DO	1	1
...
9999	10000		10000	10000
0	10001	DI	10001	10001
...
9999	20000		20000	20000
0	30001	AI	30001	30001
...
9999	40000		40000	40000
0	40001	AO	40001	40001
...
9999	50000		50000	50000

The organization of every section of the map (i.e. AI, AO) can be partitioned into different areas, called “*buffers*”, containing a contiguous number of items. For example the white cells in the following figure

Item Address	Item Value
30001	
...	
30027	
30028	
30029	
30030	
30031	
...	
...	
39999	

defines a AI buffer starting at 30027 and with length 5 (grey cells are map items not defined for the device).

Author Autore	LB-DTA	L3793	Title Titolo	PR223EF Modbus™ System Interface	ENG
ABB			Doc. No N. Doc.	1SDH000566R0001	Tot. Pag.
					14/55

Please note that:

Item Address	Item Value
30001	
...	
30027	
30028	
30029	
30030	
30031	
...	
...	
39999	

defines two different AI buffers. The first one starts at 30027 with length 2, while the second one starts at 30030 with length 3.

It's possible to query a buffer, as a whole or a portion of it, but **it's NOT possible to query two buffers within the same message: an exception response will rise up.**

Please note that PR223EF doesn't implement Digital Items.

2.1.6.1 Standard Modbus Addressing

In Modbus messages Start Address is always referred to zero.

Every single item in these sections is identified by a LOGICAL ABSOLUTE ADDRESS in the following ranges:

Data	Logical Absolute Address Range	Offset / Reference (decimal)	Offset / Reference (hex)
AI	(MIN_AI_ADDR) 30001 – 40000 (MAX_AI_ADDR)	30000 (AI_OFFSET)	0x7530
AO	40001 – 50000 (MAX_AO_ADDR)	40000 (AO_OFFSET)	0x9C40

Table 8. Modbus logical memory map

Please note that when the Master specifies the “Starting Address” into the Modbus message, it uses a LOGICAL RELATIVE ADDRESS, calculated from the LOGICAL ABSOLUTE ADDRESS:

$$\begin{aligned}
 \text{Starting Address} &= \text{LOGICAL RELATIVE ADDRESS} \\
 &= \text{LOGICAL ABSOLUTE ADDRESS} - \text{XX_OFFSET} - 1 \\
 &= \text{Item Address} - \text{XX_OFFSET} - 1
 \end{aligned}$$

Equation 1.

So the Logical Relative Address Range is 00000 – 09999 (= 0x270F, MAX_RELATIVE_ADDR) for all data types.

Moreover, items like 10005, 40001, ... are addressed like 0004, 0000, ... because the function code uniquely identifies the portion of Modbus map they belong to.

Example

Register with LOGICAL ABSOLUTE ADDRESS = 32475 will be addressed by the Master with the LOGICAL RELATIVE ADDRESS = 32475 – 30000 – 1 = 2474.

So the device performs the following check on the Starting Address field:

- Starting Address range between 0 and 9999
- Starting Address belongs to a valid part of the section pointed by the Function Code

Author Autore	LB-DTA	L3793	Title Titolo	PR223EF Modbus™ System Interface	ENG
ABB			Doc. No N. Doc.	1SDH000566R0001	Tot. Pag.
					15/55

2.1.6.2 ABB SACE Addressing

The item address is:

$$\text{Starting Address} = \text{LOGICAL ABSOLUTE ADDRESS} = \text{Item Address}$$

Equation 2

The device performs the following check on the Starting Address field:

- Starting Address congruency with the section pointed by the Function Code (see Table 8).
- Starting Address belongs to a valid part of the pointed section

2.1.7 Data Field

The data field is formed by a header part and a data value part: following points consider only the header part of this field.

In some function, there could be a 0 length data field (i.e. the message contains only the function code like in the Report Slave ID function).

There is no restriction to max data length except the maximum message length (64 bytes).

2.1.7.1 Query

Number of items [2 bytes] (except writing function 6)	Byte Count (only for writing function 16) [1 byte]
How many items to read/write	How many data bytes follow

Table 9. Query data field structure

Function Code	Data Type	Max number of items	Max byte count	Min query length	Max query length
3	AO	24	N/A	8	8
4	AI	20	N/A	8	8
6	AO	N/A (1 fixed)	N/A	8	8
16	AO	20	40	11	49

The device performs the following checks on the above-mentioned fields:

- Max number of items, conforming to the Function Code
- Byte Count congruency with the Number of Items
- Data value field length congruency with the Byte Count

Moreover, also the following checks are performed:

- (Starting Address + Number Of Items) belongs to the section pointed by the Function Code
- (Starting Address + Number Of Items) belongs to a valid part of the pointed section

2.1.7.2 Response

1. Read function codes

Byte Count (only for writing function 16) [1 byte]
How many data bytes follow

Table 10. Read function response data field structure

Function Code	Data Type	Max number of items	Max byte count	Min response length
3	AO	24	48	7
4	AI	20	40	7

2. Single item Write function codes (6)

Author Autore	LB-DTA	L3793	Title Titolo	PR223EF Modbus™ System Interface	ENG
ABB			Doc. No N. Doc.	1SDH000566R0001	Tot. Pag.
					16/55

It's simply an echo of the query message.

Function Code	Data Type	Max number of items	Max byte count	Min response length
6	AO	8	N/A	8

3. Multiple items Write function codes (16)

Starting Address [2 bytes]	Number of items [2 bytes]
Starting item	How many items to read/write

Table 11. Multiple items Write function response data field structure

So the message length is fixed and equal to 8.

Function Code	Data Type	Max number of items	Max byte count	Min response length
16	AO	20	N/A	8

2.1.8 Exception Responses

In this case, the MSb of the function code in the response message is set to one and an error code is added.

Error Code	Error Name	Meaning
01	ILLEGAL FUNCTION	The function code received in the query is not an allowable action for the slave. If a 'Poll Program Complete' command is issued, this code indicates that no program function preceded it.
02	ILLEGAL DATA ADDRESS	The data address received in the query is not an allowable address for the slave.
03	ILLEGAL DATA VALUE	A value contained in the query data field is not an allowable value for the slave.
04	SLAVE DEVICE FAILURE	An unrecoverable error occurred while the slave was attempting to perform the requested action.
06	SLAVE DEVICE BUSY	The slave is processing a long-duration program command. The master should retransmit the message later when the slave is free.

Table 12. Exception response error codes

The slave device sends no response if there is a communication error (i.e. a parity or a CRC error).

Author Autore	LB-DTA	L3793	Title Titolo	PR223EF Modbus™ System Interface	ENG
ABB			Doc. No N. Doc.	1SDH000566R0001	Tot. Pag.
					17/55

Error Code	Error Name	When
01	ILLEGAL FUNCTION	1. Device does NOT support the received Function Code.
02	ILLEGAL DATA ADDRESS	1. Starting Address is > 9999 (Standard Addressing Type). 2. Starting Address is outside a map section (ABB SACE Addressing Type). 3. Starting Address not defined. 4. Starting Address not supported by function.
03	ILLEGAL DATA VALUE	1. The message is too long. 2. Diagnostic function: sub-function is not supported ($\neq 0$) 3. The Number of Items is NOT in range ($= 0$ or $>$ Max number of items, see 2.1.7). 4. Byte Count is different from the number of bytes calculated using the number of items and the relevant data type. 5. The whole query requested buffer (Starting Address + Number of Items) doesn't belong to a device map buffer. 6. Command value different from 0 or 1.
04	SLAVE DEVICE FAILURE	1. Data with congruency byte not valid. 2. Wrong parameters (after Stop Programming command).
06	SLAVE DEVICE BUSY	1. EEPROM busy 2. Commands inhibition (see par. 6.2.2)

Table 13. PR223EF exception responses use

2.1.9 Broadcast messaging

According to Modbus protocol (see [1]), the device handles broadcast messages.

The device handles to slave address 0x00 (for functions supporting broadcast, see table below), but it hasn't to reply.

Function	Broadcast supported
0x03	No
0x04	No
0x06	Yes
0x08	No
0x10	Yes
0x11	No

Table 14. Broadcast messages

Author Autore	LB-DTA	L3793	Title Titolo	PR223EF Modbus™ System Interface	ENG
ABB			Doc. No N. Doc.	1SDH000566R0001	Tot. Pag.
					18/55

2.2 Installation and Configuration

At the first start-up, the device is configured for communication to the Remote System, i.e. Operating Mode = REMOTE. If the communication parameters are not defined (i.e. the reading of the relevant register returns an ER = 04), the device uses the following default communication parameters:

Communication parameters	Allowed values	Default values
Slave Address	{1 ... 247}	247
Baud Rate	9600 19200 bit/s	19200 bit/s
Parity	Even Odd None	Even
Addressing Type	Standard ABB SACE	Standard

Table 15. Communication Parameters

These parameters can be changed locally only using Test Unit.

Author Autore	LB-DTA	L3793	Title Titolo	PR223EF Modbus™ System Interface	ENG
ABB			Doc. No N. Doc.	1SDH000566R0001	Tot. Pag.
					19/55

3. Start-up behaviour

At start-up, data are available in a time that depends on the master polling frequency (scan rate).

The following table contains some measurements of the time passing between the reset of the device and the first valid response sent towards the Remote System. They have been obtained with different values of scan rate and for different query lengths.

The slave timeout set is 100 ms, while the scan rate is set to the maximum available: 50 ms.

All test have been done with both allowed baud rate: 19200 bit/s e 9600 bit/s, but no noticeable difference has been found.

Rather in some cases the higher transmission delay of 9600 baud rate promoted a reduced response delay, probably because the SW started the query handling later when start-up was completely ended.

Query	Min (ms)	Max (ms)	Average (ms)
Read 1 EEPROM register	36	158	87
Read 12 EEPROM registers	28	62	50
Read 1 RAM register	23	151	74
Read RAM 24 registers	26	104	62
Read 1 Flash register	20	160	88
Read 8 Flash registers	42	202	93

Table 16. Start-up time

Author Autore	LB-DTA	L3793	Title Titolo	PR223EF Modbus™ System Interface	ENG
ABB			Doc. No N. Doc.	1SDH000566R0001	Tot. Pag.
					20/55

4. Operating Mode

The device can operate in two different modes, Local and Remote. The mode can be selected through a button (LOCAL/REMOTE).

The button has toggle behaviour: its value is stored permanently. Its status is showed through a LED.

4.1 Local Operating Mode

From the remote point of view, the device has the following behaviour:

Actions forbidden	Actions allowed
No remote parameterization allowed	Consultation of measurements
No remote command allowed	Consultation of configuration parameters of the device
	Consultation of protection unit information

4.2 Remote Operating Mode

From the remote point of view, the device has the following behaviour:

Actions forbidden	Actions allowed
None	Remote parameterization allowed
	Remote command allowed
	Consultation of measurements
	Consultation of configuration parameters of the device
	Circuit Breaker commands (open / close)
	Trip Reset / CB Reset

Author Autore	LB-DTA	L3793	Title Titolo	PR223EF Modbus™ System Interface	ENG
ABB			Doc. No N. Doc.	1SDH000566R0001	Tot. Pag. 21/55

5. Configuration parameters programming model

The Protection Unit has one parameter set.

5.1 Programming model

All configuration parameters are readable, while only some of them are remotely modifiable.

All configuration parameters are items. They can be:

- READ ONLY (the system can't modify them)
The configuration parameter is associated only to an Input Item (AI)
- READ/WRITE (the system can modify them)
The configuration parameter is associated both to an Input (AI) **and** to an Output (AO) Item

Obviously, "READ/WRITE" configuration parameters are a subset of those "READ ONLY".

Author Autore	LB-DTA		L3793	Title Titolo	PR223EF Modbus™ System Interface	ENG
ABB				Doc. No N. Doc.	1SDH000566R0001	Tot. Pag.
						22/55

5.1.1 Programming Model

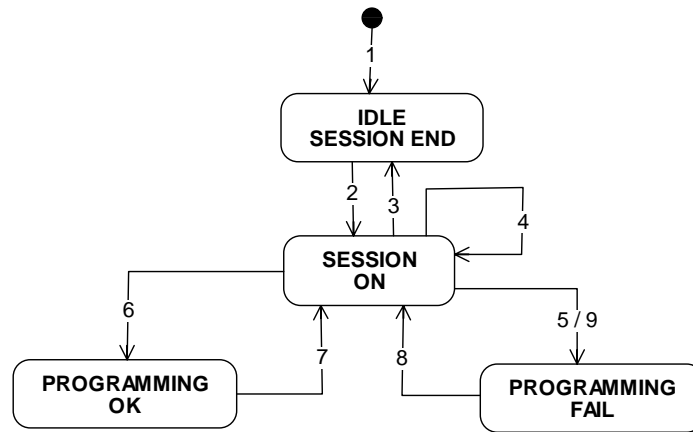

Figure 1. Remote Programming Model state chart

STATE NAME	STATE DESCRIPTION	PROGRAMMING OK Item	PROGRAMMING FAIL Item
INIT	Initial state	0	0
IDLE / SESSION END	Session is ended	0	0
SESSION ON	Session is active	1	1
PROGRAMMING OK	Session ended without errors	1	0
PROGRAMMING FAIL	Session ended with errors	0	1

TRANSITION	INITIAL STATE	FINAL STATE	TRANSITION CONDITION
1	INIT	IDLE / SESSION END	Start-up.
2	IDLE / SESSION END	SESSION ON	“Start programming” command received.
3	SESSION ON	IDLE / SESSION END	“Abort programming” command received. “Stop programming” command received with no parameter modified.
4	SESSION ON	SESSION ON	“Start programming” command received.
5	SESSION ON	PROGRAMMING FAIL	“Stop programming” command received and errors detected.
6	SESSION ON	PROGRAMMING OK	“Stop programming” command received and no error detected.
7	PROGRAMMING OK	SESSION ON	“Start programming” command received.
8	PROGRAMMING FAIL	SESSION ON	“Start programming” command received.
9	SESSION ON	PROGRAMMING FAIL	A “local” aborting event has occurred: 1. Operating Mode from REMOTE to LOCAL 2. Test Unit connection

The actions associated to each transition are:

TRANSITION	ACTION
1	N/A
2	1. Set the programming items (Programming OK Programming FAIL). 2. Reset “Programming Fail Code” item. 3. Copy the “Present parameters” buffer into “New Parameters”.
3	1. Reset the programming items.
4	1. Copy the “Present parameters” buffer into “New Parameters”.
5	1. Reset the “Programming OK” item 2. Write the “Programming Fail Code” item. 3. Return response to command with ER = 04.
6	1. Reset the “Programming Fail” item 2. Set the “Parameters Changed” item (event: reset after read).
7	1. Set the “Programming Fail” item. 2. Copy the “Present parameters” buffer into “New Parameters”.
8	1. Set the “Programming OK” item. 2. Reset “Programming Fail Code” item. 3. Copy the “Present parameters” buffer into “New Parameters”.
9	1. Reset “Programming OK” item. 2. Write the “Programming Fail Code” item.

Author Autore	LB-DTA	L3793	Title Titolo	PR223EF Modbus™ System Interface	ENG
ABB			Doc. No N. Doc.	1SDH000566R0001	Tot. Pag. 23/55

6. Commands

The device manages two different command sources:

1. Remote Operator, i.e. a remote command from the system (remote command)
2. Local Operator, i.e. an action performed locally on the circuit breaker (local command)

From now on, the word “command” means “remote command”.

6.1 Command Categories

Remote commands handled by device can be organised in two different categories:

- a) Trip Unit Commands
 - Start Programming
 - Stop Programming
 - Abort Programming
 - Trip Reset
 - Wink
 - Trip History Acquisition
 - Reset Communication Statistics
- b) Circuit Breaker Commands
 - CB Open
 - CB Close
 - CB Reset

Only the values 0 and 1 are allowed for a command.

Value 0 doesn't execute the requested action.

If a different value is sent, an exception response `ILLEGAL_DATA_VALUE` will be returned.

The commands concerning only the TU (e.g. Trip Reset) and not the Circuit Breaker are independent from CB states.

“CB Reset” command implies the “Trip Reset” command too, so this command concerns both the TU and the CB.

6.1.1 Wink Command

The “wink” command is used for recognising a device by making its LED flash.

The command is sent from the remote system and has toggle behaviour, i.e., to stop the LED flashing, another “wink” command has to be sent.

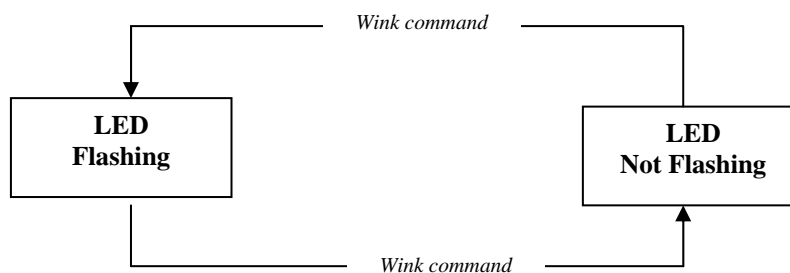

Figure 2. "Wink command" FSM

The ‘Wink’ condition is also signalled to the Remote System through a relevant Modbus register.

The same LED is used for operating mode signalling, which has priority (see also Figure 3).

6.1.2 Trip Reset

This command resets the trip signalling towards the Remote System.

6.1.3 CB Reset

This command resets the trip signalling towards the Remote System and changes the mechanical status from TRIPPED to OPEN.

This is also the behaviour when a LOCAL CB Reset command is issued by opening the CB (i.e. changing its mechanical status from TRIPPED to OPEN). CB Reset is refused if:

Author Autore	LB-DTA	L3793	Title Titolo	PR223EF Modbus™ System Interface	ENG
ABB			Doc. No N. Doc.	1SDH000566R0001	Tot. Pag.
					24/55

- CB closed
- CB open without Trip Command Fail condition

6.1.4 Remote CB Close command after Trip Command Fail

When a “Trip Command Fail” condition occurs (see its definition in par. 1.2.2), the CB reaches the Open position: in this situation, the “CB Close” command is accepted and causes a trip reset.

NB: this behaviour is different from the other ABB SACE Modbus devices (PR212/D-M, PR112/PD-M, PR113/PD-M). In this condition, it is better to send a “Trip Reset” command before the “CB Close” command to give an acknowledgement to trip.

6.1.5 CB commands inhibition

When the device sends the command, the event “CB command executed” is set. However no remote CB commands can be fulfilled if:

- the frontal AUTO / MANUAL selector on the Motor Operator is set to MANUAL
- the Motor Command is damaged
- the I²C bus connection is damaged

6.2 Commands management

6.2.1 Commands completion

After receiving a command, the device verifies the inhibition conditions and sends the response.

If there is an error, an exception response is sent and the requested command is NOT processed.

Even if there is an error or not, during this time, the relevant command item is NOT reset, signalling that the command is pending, and command completion will be signalled by the relevant item reset.

If there is NO error, the command result is signalled in the following way:

	Command result
<i>Start Programming</i>	Programming OK = Programming Fail = 1 (i.e. Remote programming session ON)
<i>Abort Programming</i>	Programming OK = Programming Fail = 0 (i.e. Remote programming session OFF)
<i>Stop Programming</i>	<ol style="list-style-type: none"> Programming result = OK <ul style="list-style-type: none"> Programming OK = 1, Programming Fail = 0 Parameter changed = 1 Present parameters are updated Programming result = FAIL <ul style="list-style-type: none"> Programming OK = 0, Programming Fail = 1 Set Programming Fail Code ER = 04 returned to “Stop Programming” query Nothing changed <ul style="list-style-type: none"> Programming OK = Programming Fail = 0
<i>Trip Reset</i>	<ol style="list-style-type: none"> Trip Command Fail reset, if previously set (mutually exclusive with CB Tripped Item). Other Trip reset, if previously set (mutually exclusive with Protection Trip Item). Relevant Trip Item reset → Any Trip reset
<i>Wink</i>	<ol style="list-style-type: none"> If Wink status = 0 <ul style="list-style-type: none"> LED blinking Wink status = 1 If Wink status = 1 <ul style="list-style-type: none"> LED stops blinking Wink status = 0
<i>Trip History Acquisition</i>	New data showed
<i>CB Open</i>	CB Open / Closed = 0
<i>CB Close</i>	CB Open / Closed = 1
<i>CB Reset</i>	<ol style="list-style-type: none"> Open command to the CB CB Tripped = 0, if previously set (mutually exclusive with Trip Command Fail Item) Trip Command Fail reset, if previously set (mutually exclusive with CB Tripped Item) Other Trip reset, if previously set (mutually exclusive with Protection Trip Item) Relevant Trip Item reset → Any Trip reset

Table 17. Command results

Author Autore	LB-DTA	L3793	Title Titolo	PR223EF Modbus™ System Interface	ENG
ABB			Doc. No N. Doc.	1SDH000566R0001	Tot. Pag.
					25/55

6.2.2 Commands inhibition

There are three different levels of command inhibition conditions:

1. functional conditions (highest)
Ex.: Abort / Stop Programming command outside a remote programming session.
2. feasibility conditions
3. security conditions (lowest)
Ex.: any remote command in Operating Mode = LOCAL

Moreover, only one command at a time can be processed, i.e. if there is another pending command (i.e. in one register the value 1 is written), the latter will be refused.

	Operating Mode LOCAL	Pending Command	CB Tripped	AUX-E Unknown	L-S-G Alarm	Current not Zero	Functional conditions for command execution
<i>Start Programming</i>	X	X			X		
<i>Abort Programming</i>	X	X			X		Programming Session ON
<i>Stop Programming</i>	X	X			X		Programming Session ON
<i>Trip Reset</i>	X	X					
<i>Wink</i>	X	X					
<i>CB Open</i>	X	X					
<i>CB Close</i>	X	X	X	X			CB OPEN & Trip Command Fail OFF
<i>CB Reset</i>	X	X		X			CB TRIPPED (CB OPEN & Trip Command Fail ON)
<i>Electronic Trip Test</i>	X	X				X	
<i>Historical Trip</i>	X	X					Value 1 ... 20

Table 18. Conditions for commands' inhibition

The refused command is signalled via an exception response 'SLAVE_DEVICE_BUSY', that means 'the device is not ready to perform the requested command'.

Author Autore	LB-DTA	L3793	Title Titolo	PR223EF Modbus™ System Interface	ENG
ABB			Doc. No N. Doc.	1SDH000566R0001	Tot. Pag. 26/55

6.3 Local Commands management

The device manages three local commands:

1. CB Open
2. CB Close
3. CB Reset

6.3.1 CB Open

A local user performs this command when she/he switches manually the circuit breaker from CLOSED to OPEN.

The device manages this command in the following way:

- CB status change
- Number of CB operations update
- Number of CB manual operations update

6.3.2 CB Close

A local user performs this command when she/he switches manually the circuit breaker from OPEN to CLOSED.

The device manages this command in the following way:

- CB status change

6.3.3 CB Reset

A local user performs this command when he switches manually the circuit breaker either from TRIPPED to OPEN (after a protection trip or another kind of trip) or from OPEN to CLOSED (after a Trip Command Fail).

The device manages this command in the following way:

- CB status change
- If the CB was in TRIPPED state, reset the relevant event and perform a Trip Reset
- If the CB was in OPEN state for TCF, reset the relevant event and perform a Trip Reset
- Reset of relevant event (any trip or another kind of trip)

Author Autore	LB-DTA		L3793	Title Titolo	PR223EF Modbus™ System Interface	ENG
ABB				Doc. No N. Doc.	1SDH000566R0001	Tot. Pag.
						27/55

7. Human Machine Interface / Local User Interface

HMI is made of one (1) button and eight (8) LEDs.

7.1 LEDS

PR223 has 8 LEDS.

LED	Colour	Description		
		OFF	ON	Blinking (2Hz, d.c. 50 %)
Protection L	Red	No alarm	L pre-alarm	L alarm
Interlocking Status	Red	Interlocking OK	Interlocking out of service	---
Settings	Red	Set parameters	Default parameters	---
Rem/Loc/Wink (*)	Yellow	Remote	Local	Wink
Neutral Selection	Yellow	OFF	100 %	50 %
Watchdog	Red	No alarm	Watchdog	---
Trip Coil	Red	TC OK	TC out of service	---
VAUX Status	Green	Self supply	Auxiliary supply	---

Table 19. LEDS

(*) "Local" signalling has priority on "Wink" one

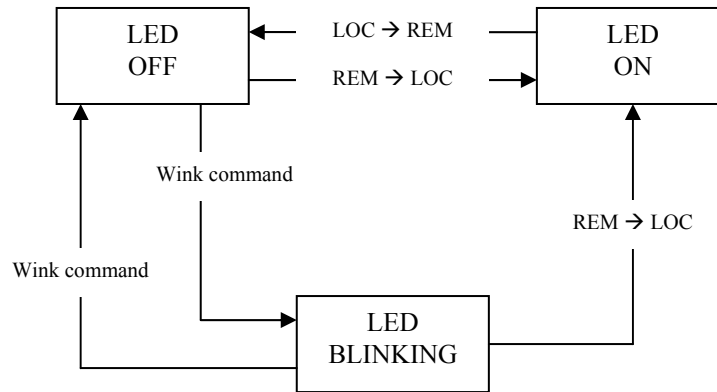

Figure 3. LED "Rem/Loc/Wink" FSM

Author Autore	LB-DTA	L3793	Title Titolo	PR223EF Modbus™ System Interface	ENG
ABB			Doc. No N. Doc.	1SDH000566R0001	Tot. Pag. 28/55

8. Modbus Logical Map

In this section are contained all the Modbus variables, both in input and in output, handled by device and accessible from the Remote System. They are divided according to their Modbus data type: Analog Input, Analog Output.
 “Persistence = PERMANENT” means that value is saved into non-volatile memory.

8.1 Data organization

8.1.1 Byte

Inside a byte, bits are organized in BIG ENDIAN structure (MSb first).

8.1.2 Word

Inside a word, bytes are organized in BIG ENDIAN structure (MSB first).

8.1.3 Double word

Inside a double word, words are organized in LITTLE ENDIAN structure (LSW first).

8.2 Bit field organization

There are some registers that are organized as bit fields. The bit field structure is:

15	14	13	12	11	10	9	8	7	6	5	4	3	2	1	0
bit 7	bit 6	bit 5	bit 4	bit 3	bit 2	bit 1	bit 0	bit 7	bit 6	bit 5	bit 4	bit 3	bit 2	bit 1	bit 0
MSB								LSB							

Table 20. Bit field organization

Each bit can be identified in two ways:

- a) MSB bit 6
- b) bit 14

In the following sections, the bit are identified in the b) way.

Author Autore	LB-DTA				L3793				Title Titolo	PR223EF Modbus™ System Interface				ENG
ABB					Doc. No N. Doc.	1SDH000566R0001				Tot. Pag.	29/55			

8.3 Registers

In this section there are all the registers that can be accessed.

- Description: it indicates name of the variable.
- Data type: it indicates how the variable can be accessed.
 - R: Read only
 - RW: Read / Write
- Range: it indicates the values that the variable can assume.
- Format: it indicates which kind of data it is
 - Integer
 - Bit field
- Function allowed: it indicates which Modbus functions can be used to access the variable.
- Absolute Address (READ): it indicates the absolute address for reading the variable.
- Absolute Address (WRITE): it indicates the absolute address for writing the variable.
- Relative Address – 1 (HEX): it indicates the relative address, in hexadecimal format, to be used into Modbus message.
- Number of registers: it indicates the number of registers that compose the variable.
- Unit of measures: it indicates the unit of measure in which the variable is represented.
- Semantics/Notes: it indicates the semantics of the value that the variable can assume or any note considered useful to correctly understand the value.

Author Autore	LB-DTA		L3793	Title Titolo	PR223EF Modbus™ System Interface	ENG
ABB				Doc. No N. Doc.	1SDH000566R0001	Tot. Pag. 30/55

8.3.1 Buffer “Communication statistics”

Description	Data Type	Range	Format	Function Allowed	Absolute Address (READ)	Absolute Address (WRITE)	Relative Address -1 (HEX)	Number of registers	Unit of measure	Semantics Notes
Communication Statistics	R		Integer	4	30001	---	0000	5		
Number of received messages	R	0 - 65535	Integer	4	30001	---	0000	1		
Number of received messages with error	R	0 - 65535	Integer	4	30002	---	0001	1		
Number of responses	R	0 - 65535	Integer	4	30003	---	0002	1		
Number of Slave Device Busy responses	R	0 - 65535	Integer	4	30004	---	0003	1		
Number of exception responses	R	0 - 65535	Integer	4	30005	---	0004	1		

Table 21. Buffer "Communication statistics"

This read-only buffer contains the counters of Modbus messages handled by the device.

They are volatile counters: at power off, their values are lost.

It is possible to reset them with a command (See paragraph 8.4.10).

When any of them reaches its maximum value, it restarts from 0.

- Number of received messages: messages received with the Slave Address of the device.
- Number of received messages with error: low level transmission errors (i.e. overrun, parity), also called “char errors”, and the CRC errors, also called “frame errors”.
- Number of responses: responses sent by trip unit (both correct and exception ones).
- Number of Slave Device Busy responses: exception responses sent by trip unit.
- Number of exception responses: exception responses ‘Slave Device Busy’ sent by trip unit. It contains also “Number of Slave Device Busy responses”.

Author Autore	LB-DTA	L3793	Title Titolo	PR223EF Modbus™ System Interface	ENG
ABB			Doc. No N. Doc.	1SDH000566R0001	Tot. Pag.
					31/55

8.3.2 Buffer "Process Statistics"

Description	Data Type	Range	Format	Function Allowed	Absolute Address (READ)	Absolute Address (WRITE)	Relative Address -1 (HEX)	Number of registers	Unit of measure	Semantics Notes
Process Statistics	R		Integer	4	30007	---	0006	12		
CB number of operations	R	0 - 65535	Integer	4	30007	---	0006	1		
CB number of manual opens	R	0 - 65535	Integer	4	30008	---	0007	1		
CB number of protection trips	R	0 - 65535	Integer	4	30009	---	0008	1		
CB number of protection trips fail	R	0 - 65535	Integer	4	30010	---	0009	1		
CB number of other trips (trip test)	R	0 - 65535	Integer	4	30011	---	000A	1		
CB number of SOS trips	R	0 - 65535	Integer	4	30012	---	000B	1		
Protection L number of trips	R	0 - 65535	Integer	4	30013	---	000C	1		
Protection S number of trips	R	0 - 65535	Integer	4	30014	---	000D	1		
Protection I number of trips	R	0 - 65535	Integer	4	30015	---	000E	1		
Protection G number of trips	R	0 - 65535	Integer	4	30016	---	000F	1		
Protection EF number of trips	R	0 - 65535	Integer	4	30017	---	0010	1		
Protection SOS number of trips	R	0 - 65535	Integer	4	30018	---	0011	1		

Table 22. Buffer "Process statistics"

This read-only buffer contains the counters of process statistics: in particular, they concern CB operations and statistics about protection trips.

They are non-volatile counters.

They can't be reset.

When any of them reaches its maximum value, it restarts from 0.

These data are protected with congruency bits into EEPROM memory: if the value is invalid, an exception response (ER = 04) is returned.

- CB number of operations: transitions towards 'Open', regardless from the cause.
- CB number of manual opens: transitions from 'Closed' to 'Open' due to opening command (local or remote).
- CB number of protection trips: transitions from 'Closed' to 'Tripped' due to device intervention after a trip.
- CB number of protection trips fail: transitions from 'Closed' to 'Tripped' due to backup procedure (through TC); transitions from 'Closed' to 'Open' due to backup procedure (through YO).
- CB number of other trips (trip test): transitions from 'Closed' to 'Tripped' due to trip test through TT1; transitions from 'Closed' to 'Tripped' due to trip test through Test Unit; transitions from 'Open' to 'Tripped' due to local test through CB test button.
- CB number of SOS trips: transitions from 'Closed' to 'Tripped' due to a SOS request from IL downlink.
- Protection L number of trips: interventions of the protection L, regardless from the result.
- Protection S number of trips: interventions of the protection S, regardless from the result.
- Protection I number of trips: interventions of the protection I, regardless from the result.
- Protection G number of trips: interventions of the protection G, regardless from the result.
- Protection EF number of trips: interventions of the protection EF, regardless from the result.
- Protection SOS number of trips: interventions for a SOS downlink request, regardless from the result.

Author Autore	LB-DTA	L3793	Title Titolo	PR223EF Modbus™ System Interface	ENG
ABB			Doc. No N. Doc.	1SDH000566R0001	Tot. Pag. 32/55

8.3.3 Buffer “Reports”

Description	Data Type	Range	Format	Function Allowed	Absolute Address (READ)	Absolute Address (WRITE)	Relative Address -1 (HEX)	Number of registers	Unit of measure	Semantics Notes
Reports	R		Integer	4	30033	---	0020	6		
Events	R		Bitfield	4	30033	---	0020	1		
NOT USED		[0 1]	Bit 0							0
Parameters changed		[0 1]	Bit 1							
CB Command executed		[0 1]	Bit 2							
Electronic trip test		[0 1]	Bit 3							
Power up after self supply		[0 1]	Bit 4							
Test Unit connected		[0 1]	Bit 5							
NOT USED		[0 1]	Bit 6							0
NOT USED		[0 1]	Bit 7							0
NOT USED		[0 1]	Bit 8							0
NOT USED		[0 1]	Bit 9							0
NOT USED		[0 1]	Bit 10							0
NOT USED		[0 1]	Bit 11							0
NOT USED		[0 1]	Bit 12							0
NOT USED		[0 1]	Bit 13							0
NOT USED		[0 1]	Bit 14							0
NOT USED		[0 1]	Bit 15							0
Status	R		Bitfield	4	30034	---	0021	1		
Any alarm		[0 1]	Bit 0							
Any trip		[0 1]	Bit 1							
CB tripped		[0 1]	Bit 2							
CB status		[0 1]	Bit 3							0 = CB open 1 = CB closed
Trip Command Fail		[0 1]	Bit 4							
Other trip		[0 1]	Bit 5							
Operating mode		[0 1]	Bit 6							0 = Remote 1 = Local
Programming OK		[0 1]	Bit 7							
Programming Fail		[0 1]	Bit 8							
NOT USED		[0 1]	Bit 9							0
NOT USED		[0 1]	Bit 10							0
EEPROM parameters error		[0 1]	Bit 11							
AUX-E unknown		[0 1]	Bit 12							
Nominal current unknown		[0 1]	Bit 13							
Serial parameters unknown		[0 1]	Bit 14							
Trip data available		[0 1]	Bit 15							
Alarms	R		Bitfield	4	30035	---	0022	1		
L Pre-alarm		[0 1]	Bit 0							
L alarm (timing/tripping)		[0 1]	Bit 1							
S alarm (timing/tripping)		[0 1]	Bit 2							
G alarm (timing/tripping)		[0 1]	Bit 3							
Motor Command overheated		[0 1]	Bit 4							
EF Alarm (Trip Delayed)		[0 1]	Bit 5							
EF Interlocked		[0 1]	Bit 6							
S Interlocked		[0 1]	Bit 7							
G Interlocked		[0 1]	Bit 8							
IL Fault uplink		[0 1]	Bit 9							
IL Fault downlink		[0 1]	Bit 10							
DSP Fault		[0 1]	Bit 11							
SOS Requested		[0 1]	Bit 12							

Author Autore	LB-DTA	L3793	Title Titolo	PR223EF Modbus™ System Interface	ENG
ABB			Doc. No N. Doc.	1SDH000566R0001	Tot. Pag. 33/55

TC error		[0 1]	Bit 13						
Frequency out of range		[0 1]	Bit 14						
NOT USED		[0 1]	Bit 15						0
Trips	R		Bitfield	4	30036	---	0023	1	
L tripped		[0 1]	Bit 0						
S tripped		[0 1]	Bit 1						
I tripped		[0 1]	Bit 2						
G tripped		[0 1]	Bit 3						
I inst tripped		[0 1]	Bit 4						
EF tripped		[0 1]	Bit 5						
SOS Tripped		[0 1]	Bit 6						
NOT USED		[0 1]	Bit 7						0
NOT USED		[0 1]	Bit 8						0
NOT USED		[0 1]	Bit 9						0
NOT USED		[0 1]	Bit 10						0
NOT USED		[0 1]	Bit 11						0
NOT USED		[0 1]	Bit 12						0
NOT USED		[0 1]	Bit 13						0
NOT USED		[0 1]	Bit 14						0
NOT USED		[0 1]	Bit 15						0
DO status	R		Bitfield	4	30037	---	0024	1	
DO1 – k51/1 status		[0 1]	Bit 0						0 = Reset 1 = Set
DO2 – k51/2 status		[0 1]	Bit 1						0 = Reset 1 = Set
DO3 – k51/3 status		[0 1]	Bit 2						0 = Reset 1 = Set
DO4 – k51/4 status		[0 1]	Bit 3						0 = Reset 1 = Set
DO5 status		[0 1]	Bit 4						0 = Reset 1 = Set
DO6 – k51/6 status		[0 1]	Bit 5						0 = Reset 1 = Set
DO7 – k51/7 status		[0 1]	Bit 6						0 = Reset 1 = Set
DO8 – k51/8 status		[0 1]	Bit 7						0 = Reset 1 = Set
NOT USED		[0 1]	Bit 8						
NOT USED		[0 1]	Bit 9						
NOT USED		[0 1]	Bit 10						
NOT USED		[0 1]	Bit 11						
NOT USED		[0 1]	Bit 12						
NOT USED		[0 1]	Bit 13						
NOT USED		[0 1]	Bit 14						
NOT USED		[0 1]	Bit 15						
Information	R		Bitfield	4	30038	---	0025	1	
Wink ON		[0 1]	Bit 0						
MOE-E unknown		[0 1]	Bit 1						
I ² C error		[0 1]	Bit 2						
Vaux present		[0 1]	Bit 3						
Valid statistics		[0 1]	Bit 4						
NOT USED		[0 1]	Bit 5						0
NOT USED		[0 1]	Bit 6						0
NOT USED		[0 1]	Bit 7						0
NOT USED		[0 1]	Bit 8						0
NOT USED		[0 1]	Bit 9						0
NOT USED		[0 1]	Bit 10						0
NOT USED		[0 1]	Bit 11						0
NOT USED		[0 1]	Bit 12						0

Author Autore	LB-DTA L3793			Title Titolo	PR223EF Modbus™ System Interface			ENG
ABB				Doc. No N. Doc.	1SDH000566R0001			Tot. Pag. 34/55

NOT USED	[0 1]	Bit 13							0
NOT USED	[0 1]	Bit 14							0
NOT USED	[0 1]	Bit 15							0

Table 23. Buffer "Reports"

This read-only buffer contains all the run-time information concerning:

- Events: events happened on trip unit and CB. They are reset after reading.
- Status: trip unit and CB status. They remain freeze until any changes.
- Alarms: alarms concerning protection algorithms. They remain freeze until any changes.
- Trips: trips concerning protection algorithms. They remain freeze until a trip reset.
- DO status: DO and k51 contacts status. They remain freeze until any changes.
- Information: general information.

These registers are organized as bit field (See § 8.2).
They are volatile data.

- Power up after self supply: event set in a transition from self-supply to auxiliary supply.
- Any alarm: set if any of alarm item is set. It is reset when all the alarm items are equal to 0.
- Any trip: set if any of trip item is set. It is reset after either a remote "Trip Reset" or a local / remote "CB Reset".
- CB tripped: the CB is in tripped mechanical state: also "CB Open" is set.
- Trip command fail: set when the device haven't succeeded in opening the CB at first attempt. After that two different back-up procedures are started:
 - the device sends periodically (100 ms) a command to TC. If successful, the CB goes into "Tripped" state.
 - if auxiliary supply and the CB I/O are present, the device sends once a command to the YO after 100 ms. If successful, the CB goes into 'Open' state.
- Other trip: set if the CB tripped state is due to a trip test, a UVR trip or a SOR trip.
- Programming OK
Programming Fail: remote programming status

Programming OK	Programming Fail	Description
0	0	Idle / Remote programming session OFF
0	1	Programming Fail
1	0	Programming OK
1	1	Remote programming session ON

- EEPROM parameters error: data in EEPROM are invalid.
- AUX-E unknown: AUX-E is not present or is not responding.
- Nominal current unknown: nominal current is not set. Current measurements are provided as percentage of In.
- Serial parameters unknown: serial parameters are not set. The defaults ones are used (see § 2.2).
- Trip data available: always ON, but when the device is storing trip data after a trip or data are not valid.
- Motor command overheated: motor command (MOE-E) overheating.
- EF Alarm: protection has reached the threshold but it doesn't intervene because it is blocked.
- EF Interlocked: protection remains interlocked because of an IL signal.
- S Interlocked: protection remains interlocked because of an IL signal.
- G Interlocked: protection remains interlocked because of an IL signal.
- IL fault uplink: there is an IL problem on uplink line (only if multi-point connection).
- IL fault downlink: there is an IL problem on downlink line (only if point-to-point connection).
- DSP fault: the DSP has problems and it doesn't work properly.
- SOS requested: an opening request is sent to upper CB.
- TC error: the TC is not connected.
- Frequency out of range: frequency value is $\pm 10\%$ of the nominal value.
- Wink status: it replies status of Wink LED. See Figure 2
- MOE-E unknown: MOE-E is not present.

Author Autore	LB-DTA	L3793	Title Titolo	PR223EF Modbus™ System Interface	ENG
ABB			Doc. No N. Doc.	1SDH000566R0001	Tot. Pag.
					35/55

- I²C error: detection of a Bus failure
- Vaux present: auxiliary supply ON: if read from system bus is always one
- Valid statistics: validity of process statistics (see § 8.3.2)

Author Autore	LB-DTA		L3793	Title Titolo	PR223EF Modbus™ System Interface	ENG
ABB				Doc. No N. Doc.	1SDH000566R0001	Tot. Pag.
						36/55

8.3.4 Buffer "Program fail code"

Description	Data Type	Range	Format	Function Allowed	Absolute Address (READ)	Absolute Address (WRITE)	Relative Address -1 (HEX)	Number of registers	Unit of measure	Semantics Notes
Program Fail Code	R		Integer	4	30051	---	0032	1		
Program Fail Code	R		Integer	4	30051	---	0032	1		

Table 24. Buffer "Program fail code"

This read-only buffer contains the program error code. It is a volatile datum: the error codes are showed into Table 25. During a programming session, the device makes some checks on the configuration parameters to find possible errors. The relevant codes are subdivided into three categories:

- 0: NO ERROR
- 1 – 1000: Error concerning device conditions
- 1001 – 2000: Errors concerning parameters
- 2001 – 3000: Other errors

Inside every block, the error codes are not consecutive to let spaces for further upgrades.

The not used error codes are intentionally left empty because they are used into the other devices (e.g. PR112/PD-M, PR113/PD-M, PR212/D-M, PR222DS/PD), so that two different devices have the same code for the same error.

System Error Code	Description
0	NO ERROR
1	EEPROM Busy
11	S Alarm
12	G Alarm
13	L Alarm
31	S Threshold \leq L Threshold (°)
32	I Threshold \leq S Threshold (°)
48	NE Setting Incompatible With L Threshold
1008	Nominal Voltage Out Of Range
1031	L Threshold Out Of Range
1033	L Time Delay Out Of Range
1042	S Threshold Out Of Range
1043	S Time Delay Out Of Range
1051	I Threshold Out Of Range
1062	G Threshold Out Of Range
1063	G Time Delay Out Of Range
1200	EF Insensibility Threshold Out Of Range
1201	EF Max Threshold Out Of Range
1300	(VM210) Neutral Presence
1301	Smart IO 1 Out Of Range
1302	Smart IO 2 Out Of Range
1303	Smart IO 3 Out Of Range
1304	Smart IO 4 Out Of Range
1305	Smart IO 5 Out Of Range
1306	Smart IO 6 Out Of Range
1307	Smart IO 7 Out Of Range
1308	Smart IO 8 Out Of Range
1309	Remote contact Out Of range
2002	Abort Program – Local
2005	Abort Program – TU connected

Table 25. Program fail codes

(°) These error codes are not generated if any of the relevant protections are disabled.

Author Autore	LB-DTA	L3793	Title Titolo	PR223EF Modbus™ System Interface	ENG
ABB			Doc. No N. Doc.	1SDH000566R0001	Tot. Pag. 37/55

8.3.5 Buffer "Currents"

Description	Data Type	Range	Format	Function Allowed	Absolute Address (READ)	Absolute Address (WRITE)	Relative Address -1 (HEX)	Number of registers	Unit of measure	Semantics Notes
Run time currents	R		Integer	4	30101	---	0064	5		
Rms current phase 1	R	0 - 65535	Integer	4	30101	---	0064	1	[A]	
Rms current phase 2	R	0 - 65535	Integer	4	30102	---	0065	1	[A]	
Rms current phase 3	R	0 - 65535	Integer	4	30103	---	0066	1	[A]	
Rms current neutral	R	0 - 65535	Integer	4	30104	---	0067	1	[A]	
Rms current ground	R	0 - 65535	Integer	4	30105	---	0068	1	[A]	

Table 26. Buffer "Currents"

This read-only buffer contains the RMS current values.
They are volatile data.

If the Nominal current is not set (see Table 23, "Nominal current unknown" = 1), values are expressed as percentage of In.
If the Nominal current is set (see Table 23, "Nominal current unknown" = 0), values are expressed in Ampere [A].

For example: if the value read 150
Nominal current unknown = 1 → 1.5 In
Nominal current unknown = 0 → 150 A

Value limits	
$I \leq 0.2 I_n$	0

8.3.6 Buffer "Voltages"

Description	Data Type	Range	Format	Function Allowed	Absolute Address (READ)	Absolute Address (WRITE)	Relative Address -1 (HEX)	Number of registers	Unit of measure	Semantics Notes
Run time voltages	R		Integer	4	30107	---	006A	6		
Rms line to neutral voltage V1	R	0 - 65535	Integer	4	30107	---	006A	1	[V*10]	
Rms line to neutral voltage V2	R	0 - 65535	Integer	4	30108	---	006B	1	[V*10]	
Rms line to neutral voltage V3	R	0 - 65535	Integer	4	30109	---	006C	1	[V*10]	
Rms line to line voltage V12	R	0 - 65535	Integer	4	30110	---	006D	1	[V*10]	
Rms line to line voltage V23	R	0 - 65535	Integer	4	30111	---	006E	1	[V*10]	
Rms line to line voltage V31	R	0 - 65535	Integer	4	30112	---	006F	1	[V*10]	

Table 27. Buffer "Voltages"

This read-only buffer contains the RMS voltage values.
They are volatile data.

Their values are expressed as tenth of volt. For example: if the value read is 150, it means 15 V.

Value limits	
$V \leq 80 V$	0
V not available	0xFFFF

The "line to neutral voltage" values are not meaningful if the plant has no neutral ("not available" value is provided).
These data are unavailable if VM210 module is not present (zero value is provided).

Author Autore	LB-DTA	L3793	Title Titolo	PR223EF Modbus™ System Interface	ENG
ABB			Doc. No N. Doc.	1SDH000566R0001	Tot. Pag. 38/55

8.3.7 Buffer "Other measurements"

Description	Data Type	Range	Format	Function Allowed	Absolute Address (READ)	Absolute Address (WRITE)	Relative Address -1 (HEX)	Number of registers	Unit of measure	Semantics Notes
Run time other measurements	R		Integer	4	30139	---	008A	6		
Peak Factor phase 1	R		Integer	4	30139	---	008A	1	[value*100]	
Peak Factor phase 2	R		Integer	4	30140	---	008B	1	[value*100]	
Peak Factor phase 3	R		Integer	4	30141	---	008C	1	[value*100]	
Peak Factor Ne phase	R		Integer	4	30142	---	008D	1	[value*100]	

Table 28. Buffer "Other measurements"

This read-only buffer contains the following measurements:

- Peak factors (PF): the value is expressed as hundredth of the relevant unit of measurement.
For example: if the value read is 141, it means 1.41.
If current is zero, the peak factor of the relevant phase is set to 0.

Author Autore	LB-DTA	L3793	Title Titolo	PR223EF Modbus™ System Interface	ENG
ABB			Doc. No N. Doc.	1SDH000566R0001	Tot. Pag. 39/55

8.3.8 Buffer "Trip currents"

Description	Data Type	Range	Format	Function Allowed	Absolute Address (READ)	Absolute Address (WRITE)	Relative Address -1 (HEX)	Number of registers	Unit of measure	Semantics Notes
Last trip currents	R		Integer	4	30201	---	00C8	5		
Trip current phase 1	R	0 - 65535	Integer	4	30201	---	00C8	1	[A]	
Trip current phase 2	R	0 - 65535	Integer	4	30202	---	00C9	1	[A]	
Trip current phase 3	R	0 - 65535	Integer	4	30203	---	00CA	1	[A]	
Trip current neutral	R	0 - 65535	Integer	4	30204	---	00CB	1	[A]	
Trip current ground	R	0 - 65535	Integer	4	30205	---	00CC	1	[A]	

Table 29. Buffer "Trip currents"

This read-only buffer contains the currents measured at last trip event.

They are non-volatile values.

These data are protected with congruency bits into EEPROM memory: if the value is invalid, an exception response (ER = 04) is returned.

If no trip has occurred, an exception response (ER = 04) is returned.

Value limits	
$I \leq 0.1 I_n$	0
I not available	0xFFFF

Author Autore	LB-DTA	L3793	Title Titolo	PR223EF Modbus™ System Interface	ENG
ABB			Doc. No N. Doc.	1SDH000566R0001	Tot. Pag.
					40/55

8.3.9 Buffer “Trip reports”

Description	Data Type	Range	Format	Function Allowed	Absolute Address (READ)	Absolute Address (WRITE)	Relative Address -1 (HEX)	Number of registers	Unit of measure	Semantics Notes
Last trip reports	R		Integer	4	30273	---	0110	7		
Events	R		Bitfield	4	30273	---	0110	1		
Status	R		Bitfield	4	30274	---	0111	1		
Alarms	R		Bitfield	4	30275	---	0112	1		
Trips	R		Bitfield	4	30276	---	0113	1		
Last tripped protection threshold	R		Integer	4	30277	---	0114	1		
Last tripped protection time delay	R		Integer	4	30278	---	0115	1		
Last tripped protection curve type	R		Integer	4	30279	---	0116	1		

Table 30. Buffer "Trip reports"

This buffer contains the reports structure at last trip event and parameter settings of the protection tripped. They are non-volatile values.

- “Events”, “Status”, “Alarms”, and “Trips”: have the same structure as “Reports” (see par. 8.3.3).
- Last tripped protection threshold: threshold of the protection tripped. For the format, see par. 8.3.10.
- Last tripped protection time delay: time delay of the protection tripped. For the format, see par. 8.3.10.
- Last tripped protection curve type: curve type of the protection tripped. For the format, see par. 8.3.10.

These data are protected with congruency bits into EEPROM memory but even if the value is invalid, no exception response is returned. The master has to validate data by itself looking for the trip cause, if no trip bit set, or all bit are “1” then data must be discarded.

Author Autore	LB-DTA			L3793			Title Titolo	PR223EF Modbus™ System Interface	ENG
ABB							Doc. No N. Doc.	1SDH000566R0001	Tot. Pag.
								41/55	

8.3.10 Buffer "Parameters"

Description	Data Type	Range	Format	Function Allowed	Absolute Address (READ)	Absolute Address (WRITE)	Relative Address -1 (HEX)	Number of registers	Unit of measure	Semantics Notes
Parameters	RW		Integer	3, 4, 6, 16	30328	40328	0147	21		
Plant Nominal Voltage	RW	0 ÷ 22	Integer	3, 4, 6, 16	30328	40328	147	1		See Table 32
DO 1 - k51/1 contact configuration	RW		Integer	3, 4, 6, 16	30329	40329	0148	1		
DO 2 - k51/2 contact configuration	RW		Integer	3, 4, 6, 16	30330	40330	0149	1		
DO 3 - k51/3 contact configuration	RW		Integer	3, 4, 6, 16	30331	40331	014A	1		
DO 4 - k51/4 contact configuration	RW		Integer	3, 4, 6, 16	30332	40332	014B	1		
DO 5 configuration	RW		Integer	3, 4, 6, 16	30333	40333	014C	1		
DO 6 - k51/6 contact configuration	RW		Integer	3, 4, 6, 16	30334	40334	014D	1		
DO 7 - k51/7 contact configuration	RW		Integer	3, 4, 6, 16	30335	40335	014E	1		
DO 8 - k51/8 contact configuration	RW		Integer	3, 4, 6, 16	30336	40336	014F	1		
VM210 Neutral Presence	RW		Integer	3, 4, 6, 16	30337	40337	0150	1		0 = Absent 1 = Present
Date of test	RW		Integer	3, 4, 6, 16	30338	40338	0151	3		DD / MM / YYYY
Protection L trip level	RW	0.18 ÷ 1.00 step 0.01	Integer	3, 4, 6, 16	30341	40341	0154	1	In	18 ÷ 100 step 1
Protection L trip delay	RW	3 ÷ 18 step 0.5	Integer	3, 4, 6, 16	30342	40342	0155	1	s	300 ÷ 1800 step 50
Protection S trip level	RW	0.6 ÷ 10 step 0.01	Integer	3, 4, 6, 16	30343	40343	0156	1	In	60 ÷ 1000 step 10
Protection S trip delay	RW	0.05 ÷ 0.5 step 0.01	Integer	3, 4, 6, 16	30344	40344	0157	1	s	5 ÷ 50 step 1
Protection I trip level	RW	1.5 ÷ 12 step 0.01	Integer	3, 4, 6, 16	30345	40345	0158	1	In	150 ÷ 1200 step 1
Protection G trip level	RW	0.2 ÷ 1 step 0.01	Integer	3, 4, 6, 16	30346	40346	0159	1	In	20 ÷ 100 step 1
Protection G trip delay	RW	0.1 ÷ 0.8 step 0.01	Integer	3, 4, 6, 16	30347	40347	015A	1	s	10 ÷ 80 step 1
Protection Status	RW		Bitfield	3, 4, 6, 16	30348	40348	015B	1		
Protection L pre-alarm disable	RW	[0 1]	Bit 0							0 = Enabled 1 = Disabled
Protection S disable	RW	[0 1]	Bit 1							0 = Enabled 1 = Disabled
Protection S inverse time curve	RW	[0 1]	Bit 2							0 = Definite Time 1 = Inv. Time
Protection I disable	RW	[0 1]	Bit 3							0 = Enabled 1 = Disabled
Protection G disable	RW	[0 1]	Bit 4							0 = Enabled 1 = Disabled
EF disable	RW	[0 1]	Bit 5							0 = Enabled 1 = Disabled
EF Trip Delayed	RW	[0 1]	Bit 6							0 = Normal 1 = Trip Delayed
NOT USED										0
Uplink configuration	RW	[0 1]	Bit 8							0 = Point-to-point 1 = Multipoint
Downlink configuration	RW	[0 1]	Bit 9							0 = Point-to-point 1 = Multipoint
Neutral disable	RW	[0 1]	Bit 10							0 = Enabled 1 = Disabled
Neutral selection	RW	[0 1]	Bit 11							0 = 50% 1 = 100%
Frequency selection	RW	[0 1]	Bit 12							0 = 50 Hz 1 = 60 Hz

Table 31. Buffer "Parameters"

This read-write buffer contains the configuration of the trip unit.
These parameters can be written inside a programming session (see par. 5).

1. "Start Programming" command

Author Autore	LB-DTA	L3793	Title Titolo	PR223EF Modbus™ System Interface	ENG
ABB			Doc. No N. Doc.	1SDH000566R0001	Tot. Pag. 42/55

2. Write parameters (AO)
3. "Stop Programming" command

They are non-volatile values.

NB: if these data are not valid, an ER = 04 is returned and the relevant bit (EEPROM parameters error) is set into "Status" structure.

- Plant Nominal Voltages: allowed values are

Code	Description
0	100 V
1	115 V
2	120 V
3	190 V
4	208 V
5	220 V
6	230 V
7	240 V
8	277 V
9	347 V
10	380 V
11	400 V
12	415 V
13	440 V
14	480 V
15	500 V
16	550 V
17	600 V
18	660 V
19	690 V
20	910 V
21	950 V
22	1000 V

Table 32. Plant nominal voltages

					Title Titolo	PR223EF Modbus™ System Interface	ENG
Author Autore	LB-DTA		L3793		Doc. No N. Doc.	1SDH000566R0001	Tot. Pag.
ABB							43/55

- DO x – k51/x configuration: any contact can be programmed. The status can be read into section described into par. 8.3.3
The allowed values are:

Code	Description
0	None
1	Parameters changed
2	Test unit connected
3	Test unit not connected
4	CB Tripped
5	CB Closed
6	CB Open
7	CB status Undefined
8	CB status Defined
9	Trip Command Fail
10	Local Operating Mode
11	Remote Operating Mode
12	Any Alarm
13	L Pre-Alarm status
14	L Timing status
15	S Timing status
16	G Timing status
17	EF Alarm status
18	EF Interlocked
19	S Interlocked
20	G Interlocked
21	Interlocking fault Uplink
22	Interlocking fault Downlink
23	SOS Requested
24	Trip Coil Alarm status
25	MOE-E over temperature Alarm status
26	Frequency Alarm status
27	Any Trip
28	L tripped
29	S tripped
30	I tripped
31	Iinst tripped
32	G tripped
33	EF tripped
34	SOS trip
35	Trip Reset Event
36	Vaux ON
37	Vaux OFF
38	MOE-E present
39	MOE-E absent

Table 33. DO configuration

- Protection L time delay: the range changes according to CB Type. See Table 34 for details.
- Protection I threshold: the range changes according to CB Type. See Table 34 for details.

CB Type	Protection L electronic time delay	Protection S electronic threshold	Protection I electronic threshold
T4-320 T5-630 T6-1000	3 ... 10.5 s step 0.5 s	0.6 ... 9.5 I _N step 0.1 I _N	1.5 ... 9.5 I _N step 0.1 I _N
T6-800A	3 ... 18 s step 0.5 s	0.6 ... 10 I _N step 0.1 I _N	1.5 ... 10.5 I _N step 0.1 I _N
T4 - T5 - T6	3 ... 18 s step 0.5 s	0.6 ... 10 I _N step 0.1 I _N	1.5 ... 12 I _N step 0.1 I _N

Table 34. Parameters limitation according to CB type/TA Size

Author	LB-DTA			Title	PR223EF Modbus™ System Interface	ENG
Autore	L3793			Titolo		
ABB				Doc. No	1SDH000566R0001	Tot. Pag.
				N. Doc.		

- EF Trip delayed: it indicates the last CB of the chain. It is set if a SM210 module is present. The trip unit has default values for these parameters:

Parameters	Default values
DO 1 - k51/1 contact configuration	Not configured (0)
DO 2 - k51/2 contact configuration	Not configured (0)
DO 3 - k51/3 contact configuration	Not configured (0)
DO 4 - k51/4 contact configuration	Not configured (0)
DO 5 configuration	Not configured (0)
DO 6 - k51/6 contact configuration	Not configured (0)
DO 7 - k51/7 contact configuration	Not configured (0)
DO 8 - k51/8 contact configuration	Not configured (0)
(VM210) Neutral Presence	0 (Absent)
Date of test	01/01/2001
Protection L trip level	1 In
Protection L trip delay	12 s
Protection S trip level	3 In
Protection S trip delay	0.05 s
Protection I trip level	4 In
Protection G trip level	1 In
Protection G trip delay	0.8 s
Protection L pre-alarm disable	Enabled (0)
Protection S disable	Disabled (1)
Protection S inverse time curve	Inverse time (1)
Protection I disable	Enabled (0)
Protection G disable	Disabled (1)
EF disable	Enabled (0)
EF Trip Delayed	Normal (0)
Uplink configuration	Multi-point (1)
Downlink configuration	Point-to-point (0)
Neutral disable	Disabled (1)
Neutral selection	100 % (1)
Frequency selection	50 Hz (0)

Table 35. Parameters default values

Author Autore	LB-DTA			L3793		Title Titolo	PR223EF Modbus™ System Interface	ENG
ABB						Doc. No N. Doc.	1SDH000566R0001	Tot. Pag.
								45/55

8.3.11 Buffer “Device Serial Number”

Description	Data Type	Range	Format	Function Allowed	Absolute Address (READ)	Absolute Address (WRITE)	Relative Address -1 (HEX)	Number of registers	Unit of measure	Semantics Notes
Device Serial Number	R		Integer	4	30352	---	015F	8		
Device Serial Number	R		Integer	4	30352	---	015F	8		ASCII characters

This read-only buffer contains the device serial number.
It is represented with ASCII code of the characters.
Default for this buffer is ALL zero.

8.3.12 Buffer “Communication parameters”

Description	Data Type	Range	Format	Function Allowed	Absolute Address (READ)	Absolute Address (WRITE)	Relative Address -1 (HEX)	Number of registers	Unit of measure	Semantics Notes
Communication Parameters	R		Integer	4	30361	---	0168	1		
Communication Parameters	R		Bitfield	4	30361	---	0168	1		
Slave Address	R	1 ... 247	Bit 0...Bit 7							
Baud Rate	R	[0 1]	Bit 8							0 = 9600 bit/s 1 = 19200 bit/s
Parity	R	[00 01 10]	Bit 9...Bit 10							00 = Even 01 = Odd 10 = None
Addressing Type	R	[0 1]	Bit 10							0 = ABB 1 = Standard

Table 36. Buffer "Communication parameters"

This read-only buffer contains the communication parameters used by the trip unit. See par.2.2.
It is possible to change them by using Test Unit.
If these data are not valid, an ER = 04 is returned and the default parameters are used (see Table 15).

8.3.13 Buffer “System disconnection timeout”

Description	Data Type	Range	Format	Function Allowed	Absolute Address (READ)	Absolute Address (WRITE)	Relative Address -1 (HEX)	Number of registers	Unit of measure	Semantics Notes
System disconnection timeout	R		Integer	4	30363	---	016A	1		
System disconnection timeout	R	0 ÷ 6000 step 1 [10 ms]	Integer	4	30363	---	016A	1		

Table 37. Buffer "System disconnection timeout"

This read-only buffer contains the disconnection time-out.
It is possible to change it by using Test Unit.
The value is expressed in tenth of milliseconds. For example, if the value read is 10, it means 100 ms.
If these data are not valid, an ER = 04 is returned and the default parameters are used (1 s → 100).

Author Autore	LB-DTA	L3793	Title Titolo	PR223EF Modbus™ System Interface	ENG
ABB			Doc. No N. Doc.	1SDH000566R0001	Tot. Pag. 46/55

8.3.14 Buffer “Nominal current”

Description	Data Type	Range	Format	Function Allowed	Absolute Address (READ)	Absolute Address (WRITE)	Relative Address -1 (HEX)	Number of registers	Unit of measure	Semantics Notes
Nominal current	R		Integer	4	30365		016C	1		
Nominal current	R		Integer	4	30365		016C	1		

Table 38. Buffer "Nominal current"

This read-only buffer contains the nominal current value.
It is possible to change it by using Test Unit.

160 A
250 A
320 A
400 A
630 A
800 A
1000 A

Table 39. Nominal current allowed values

There is a check to verify that the value is inside the allowed ranges, but no congruency check is made against “CB type”.
If these data are not valid, an ER = 04 is returned.

8.3.15 Buffer “CB type”

Description	Data Type	Range	Format	Function Allowed	Absolute Address (READ)	Absolute Address (WRITE)	Relative Address -1 (HEX)	Number of registers	Unit of measure	Semantics Notes
CB Type	R		Integer	4	30367	---	016E	1		
CB Type	R	[0 1 2]	Integer	4	30367	---	016E	1		0 = T4 1 = T5 2 = T6

Table 40. Buffer "CB type"

This read-only buffer contains the CB Type.
The CB type is represented by an index: no control is made on data validity.

Author Autore	LB-DTA	L3793	Title Titolo	PR223EF Modbus™ System Interface	ENG
ABB			Doc. No N. Doc.	1SDH000566R0001	Tot. Pag. 47/55

8.3.16 Buffer "SW version"

Description	Data Type	Range	Format	Function Allowed	Absolute Address (READ)	Absolute Address (WRITE)	Relative Address -1 (HEX)	Number of registers	Unit of measure	Semantics Notes
SW version	R		Integer	4	30371	---	0172	1		
SW version	R	MM.mm	Integer	4	30371	---	0172	1		

Table 41. Buffer "SW version"

This read-only buffer contains the SW version, represented in hexadecimal format. It is represented in two bytes:

MSB	Major version (MM)
LSB	Minor version (mm)

Author Autore	LB-DTA	L3793	Title Titolo	PR223EF Modbus™ System Interface	ENG
ABB			Doc. No N. Doc.	1SDH000566R0001	Tot. Pag.
					48/55

8.3.17 Buffer "TAG name & User data"

Description	Data Type	Range	Format	Function Allowed	Absolute Address (READ)	Absolute Address (WRITE)	Relative Address -1 (HEX)	Number of registers	Unit of measure	Semantics Notes
TAG name & User data	RW		Integer	3, 6, 16	30377	40377	0178	10		
TAG name	RW		Integer	3, 6, 16	30377	40377	0178	5		ASCII characters
User data	RW		Integer	3, 6, 16	30382	40382	017D	5		ASCII characters

Table 42. Buffer "TAG name & user data"

This read-write buffer contains the information written by the user.
They are represented with ASCII code of the characters.

Author Autore	LB-DTA	L3793	Title Titolo	PR223EF Modbus™ System Interface	ENG
ABB			Doc. No N. Doc.	1SDH000566R0001	Tot. Pag.
					49/55

8.3.18 Buffer “Historical trips”

Description	Data Type	Range	Format	Function Allowed	Absolute Address (READ)	Absolute Address (WRITE)	Relative Address -1 (HEX)	Number of registers	Unit of measure	Semantics Notes
Historical trip reports	R		Integer	4	31000	---	03E7	13		
Current Phase 1	R	0 - 65535	Integer	4	31000	---	03E7	1	[A]	
Current Phase 2	R	0 - 65535	Integer	4	31001	---	03E8	1	[A]	
Current Phase 3	R	0 - 65535	Integer	4	31002	---	03E9	1	[A]	
Current Neutral	R	0 - 65535	Integer	4	31003	---	03EA	1	[A]	
Current Ground	R	0 - 65535	Integer	4	31004	---	03EB	1	[A]	
Events	R		Bitfield	4	31005	---	03EC	1		
NOT USED		[0 1]	Bit 0							0
Parameters changed		[0 1]	Bit 1							
CB Command executed		[0 1]	Bit 2							
Electronic trip test		[0 1]	Bit 3							
Self supply		[0 1]	Bit 4							
Test Unit connected		[0 1]	Bit 5							
NOT USED		[0 1]	Bit 6							0
NOT USED		[0 1]	Bit 7							0
NOT USED		[0 1]	Bit 8							0
NOT USED		[0 1]	Bit 9							0
NOT USED		[0 1]	Bit 10							0
NOT USED		[0 1]	Bit 11							0
NOT USED		[0 1]	Bit 12							0
NOT USED		[0 1]	Bit 13							0
NOT USED		[0 1]	Bit 14							0
NOT USED		[0 1]	Bit 15							0
Status	R		Bitfield	4	31006	---	03ED	1		
Any alarm		[0 1]	Bit 0							
Any trip		[0 1]	Bit 1							
CB tripped		[0 1]	Bit 2							
CB status		[0 1]	Bit 3							0 = CB open 1 = CB closed
Trip Command Fail		[0 1]	Bit 4							
Other trip		[0 1]	Bit 5							
Operating mode		[0 1]	Bit 6							0 = Remote 1 = Local
Programming OK		[0 1]	Bit 7							
Programming Fail		[0 1]	Bit 8							
NOT USED		[0 1]	Bit 9							0
NOT USED		[0 1]	Bit 10							0
EEPROM parameters error		[0 1]	Bit 11							
AUX-E unknown		[0 1]	Bit 12							
Nominal current unknown		[0 1]	Bit 13							
Serial parameters unknown		[0 1]	Bit 14							
Trip data available		[0 1]	Bit 15							
Alarms	R		Bitfield	4	31007	---	03EE	1		
L Pre-alarm		[0 1]	Bit 0							
L alarm (timing/tripping)		[0 1]	Bit 1							
S alarm (timing/tripping)		[0 1]	Bit 2							
G alarm (timing/tripping)		[0 1]	Bit 3							
Motor Command overheated		[0 1]	Bit 4							
EF Alarm		[0 1]	Bit 5							
EF Interlocked		[0 1]	Bit 6							
S Interlocked		[0 1]	Bit 7							

Author Autore	LB-DTA L3793			Title Titolo	PR223EF Modbus™ System Interface	ENG
ABB				Doc. No N. Doc.	1SDH000566R0001	Tot. Pag. 50/55

G Interlocked		[0 1]	Bit 8							
IL Fault uplink		[0 1]	Bit 9							
IL Fault downlink		[0 1]	Bit 10							
DSP Fault		[0 1]	Bit 11							
SOS Requested		[0 1]	Bit 12							
TC error		[0 1]	Bit 13							
Frequency out of range		[0 1]	Bit 14							
NOT USED		[0 1]	Bit 15							0
Trips	R		Bitfield	4	31008	---	03EF	1		
L tripped		[0 1]	Bit 0							
S tripped		[0 1]	Bit 1							
I tripped		[0 1]	Bit 2							
G tripped		[0 1]	Bit 3							
I inst tripped		[0 1]	Bit 4							
EF tripped		[0 1]	Bit 5							
SOS Tripped		[0 1]	Bit 6							
NOT USED		[0 1]	Bit 7							0
NOT USED		[0 1]	Bit 8							0
NOT USED		[0 1]	Bit 9							0
NOT USED		[0 1]	Bit 10							0
NOT USED		[0 1]	Bit 11							0
NOT USED		[0 1]	Bit 12							0
NOT USED		[0 1]	Bit 13							0
NOT USED		[0 1]	Bit 14							0
NOT USED		[0 1]	Bit 15							0
Protection threshold	R		Integer	4	31009	---	03F0	1		
Protection time delay	R		Integer	4	31010	---	03F1	1		
Protection curve type	R		Integer	4	31011	---	03F2	1		
Index	R	1...20	Integer	4	31012	---	03F3	1		

Table 43. Buffer "Historical trip report"

This read-only buffer contains the data recorded during a trip. The trip unit is able to record up to 20 different trips. The user must send the relevant command (see par. 8.4.9), showing the index of the trip she/he wants to read. The lowest the index is, the most recently the trip has happened.

The structure contains the same information contained into the structures described into par. 8.3.8 and par. 8.3.9. Besides, the index of trip is showed.

Author Autore	LB-DTA				L3793				Title Titolo	PR223EF Modbus™ System Interface		ENG
ABB								Doc. No N. Doc.	1SDH000566R0001		Tot. Pag.	
											51/55	

8.4 Commands

In this section there are all the commands that can be handled.

- Description: it indicates name of the command.
- Range: it indicates the values that the variable can assume.
- Format: it indicates which kind of data it is
 - Integer
 - Bit field
- Functions allowed: it indicates which Modbus functions can be used to access the command.
- Absolute Address (WRITE): it indicates the absolute address for writing the command.
- Relative Address – 1 (HEX): it indicates the relative address, in hexadecimal format, to be used into Modbus message.
- Number of registers: it indicates the number of registers that compose the command.
- Unit of measures: it indicates the unit of measure in which the variable is represented.
- Semantics/Notes: it indicates the semantics of the value that the command can assume or any note considered useful to correctly understand the value.

Commands contained into grey cells are for PR223EF only.

8.4.1 Buffer “CB Open” command

Description	Data Type	Range	Format	Function Allowed	Absolute Address (READ)	Absolute Address (WRITE)	Relative Address -1 (HEX)	Number of registers	Unit of measure	Semantics Notes
CB Open Command	C	[0 1]	Integer	6, 16		40001	0000	1		0 = No execution 1 = Execution

Table 44. Buffer "CB Open" command

This command allows opening the CB.

The conditions for executing the command are described into par. 6.2.2.

8.4.2 Buffer “CB Close” command

Description	Data Type	Range	Format	Function Allowed	Absolute Address (READ)	Absolute Address (WRITE)	Relative Address -1 (HEX)	Number of registers	Unit of measure	Semantics Notes
CB Close Command	C	[0 1]	Integer	6, 16		40003	0002	1		0 = No execution 1 = Execution

Table 45. Buffer "CB Close" command

This command allows closing the CB.

The conditions for executing the command are described into par. 6.2.2.

8.4.3 Buffer “CB Reset” command

Description	Data Type	Range	Format	Function Allowed	Absolute Address (READ)	Absolute Address (WRITE)	Relative Address -1 (HEX)	Number of registers	Unit of measure	Semantics Notes
CB Reset Command	C	[0 1]	Integer	6, 16		40005	0004	1		0 = No execution 1 = Execution

Table 46. Buffer "CB Reset" command

This command allows resetting the CB.

The conditions for executing the command are described into par. 6.2.2.

Author Autore	LB-DTA	L3793	Title Titolo		PR223EF Modbus™ System Interface		ENG
ABB				Doc. No N. Doc.	1SDH000566R0001		Tot. Pag.
							52/55

8.4.4 Buffer “Start programming session” command

Description	Data Type	Range	Format	Function Allowed	Absolute Address (READ)	Absolute Address (WRITE)	Relative Address -1 (HEX)	Number of registers	Unit of measure	Semantics Notes
Start Programming Command	C	[0 1]	Integer	6, 16		40007	0006	1		0 = No execution 1 = Execution

Table 47. Buffer "Start programming session" command

This command allows opening the programming session.
The conditions for executing the command are described into par. 6.2.2.

8.4.5 Buffer “Abort programming session” command

Description	Data Type	Range	Format	Function Allowed	Absolute Address (READ)	Absolute Address (WRITE)	Relative Address -1 (HEX)	Number of registers	Unit of measure	Semantics Notes
Abort Programming Command	C	[0 1]	Integer	6, 16		40009	0008	1		0 = No execution 1 = Execution

Table 48. Buffer "Abort programming session" command

This command allows aborting the programming session.
The conditions for executing the command are described into par. 6.2.2.

8.4.6 Buffer “Stop programming session” command

Description	Data Type	Range	Format	Function Allowed	Absolute Address (READ)	Absolute Address (WRITE)	Relative Address -1 (HEX)	Number of registers	Unit of measure	Semantics Notes
Stop Programming Command	C	[0 1]	Integer	6, 16		40011	000A	1		0 = No execution 1 = Execution

Table 49. "Stop programming session" command

This command allows closing the programming session.
The conditions for executing the command are described into par. 6.2.2.

8.4.7 Buffer “Trip Reset” command

Description	Data Type	Range	Format	Function Allowed	Absolute Address (READ)	Absolute Address (WRITE)	Relative Address -1 (HEX)	Number of registers	Unit of measure	Semantics Notes
Trip Reset Command	C	[0 1]	Integer	6, 16		40013	000C	1		0 = No execution 1 = Execution

Table 50. Buffer "Trip Reset" command

This command allows resetting the trip unit.
The conditions for executing the command are described into par. 6.2.2.

Author Autore	LB-DTA		L3793		Title Titolo	PR223EF Modbus™ System Interface				ENG
ABB					Doc. No N. Doc.	1SDH000566R0001				Tot. Pag.
										53/55

8.4.8 Buffer "Wink" command

Description	Data Type	Range	Format	Function Allowed	Absolute Address (READ)	Absolute Address (WRITE)	Relative Address -1 (HEX)	Number of registers	Unit of measure	Semantics Notes
Wink Command	C	[0 1]	Integer	6, 16		40023	0016	1		0 = No execution 1 = Execution

Table 51. Buffer "Wink" command

This command allows winking the trip unit.
The conditions for executing the command are described into par. 6.2.2.
The description of the behaviour is described into par. 6.1.1.

8.4.9 Buffer "Trip history acquisition" command

Description	Data Type	Range	Format	Function Allowed	Absolute Address (READ)	Absolute Address (WRITE)	Relative Address -1 (HEX)	Number of registers	Unit of measure	Semantics Notes
Trip History Acquisition Command	C	1...20	Integer	6, 16		40025	0018	1		

Table 52. Buffer "Trip history acquisition" command

This command allows getting trip historical data.
The conditions for executing the command are described into par. 6.2.2.
If the requested data are not valid, an exception response 04 is returned.

8.4.10 Buffer "Reset communication statistics" command

Description	Data Type	Range	Format	Function Allowed	Absolute Address (READ)	Absolute Address (WRITE)	Relative Address -1 (HEX)	Number of registers	Unit of measure	Semantics Notes
Reset communication statistics Command	C	[0 1]	Integer	6, 16		40027	001A	1		

Table 53. Buffer "Reset communication statistics" command

This command allows resetting communication statistics counters.
The conditions for executing the command are described into par. 6.2.2.

Author Autore	LB-DTA		L3793		Title Titolo	PR223EF Modbus™ System Interface				ENG
ABB					Doc. No N. Doc.	1SDH000566R0001				Tot. Pag.
										54/55

9. Revision History

9.1 Revision a – 2006/02/24

First release.

Author Autore	LB-DTA		L3793	Title Titolo	PR223EF Modbus™ System Interface	ENG
ABB				Doc. No N. Doc.	1SDH000566R0001	Tot. Pag.
						55/55