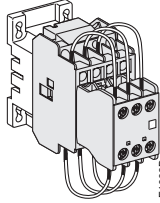
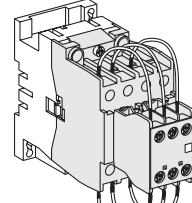
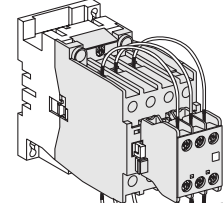
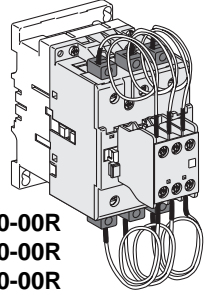
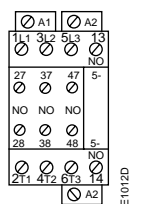
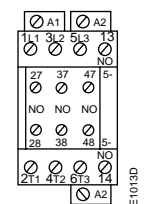
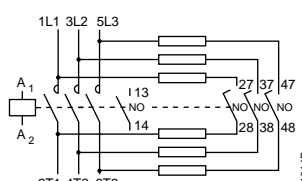
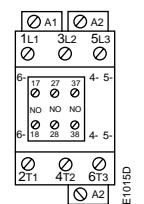
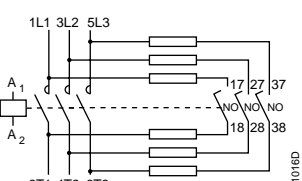
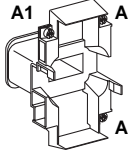
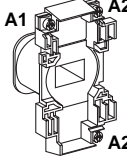
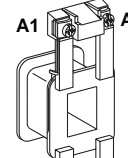
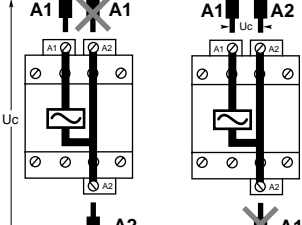
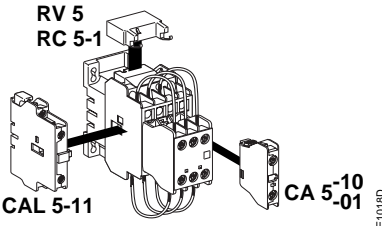
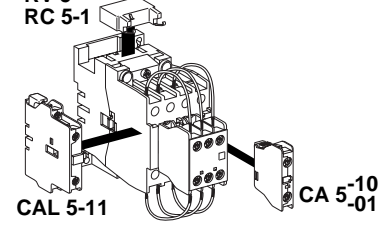
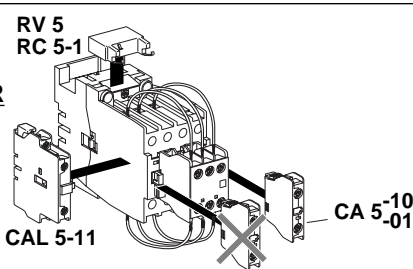
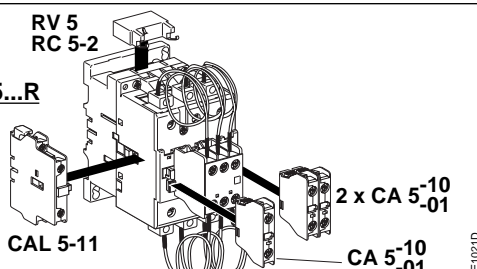

Operating instructions
Betriebsanleitung
Notice d'instructions
Instruktion
Istruzioni tecniche
Instrucciones de empleo

Contactors for capacitors switching
Schütze zum Schalten von Kondensatoren
Contacteurs pour la commande de condensateurs
Kontaktorer för kondensatorbatterier
Contattori per Inserzione condensatori
Contactores para conexión de condensadores

FPTC 407739 P0001-11/98

| | | | | | | | | | |
|---|--|---|--|--|--|---|--|---|--|
|  <p>UA16-30-10R</p> | |  <p>UA26-30-10R</p> | |  <p>UA30-30-10R</p> | |  <p>UA50-30-00R UA63-30-00R UA75-30-00R</p> | | | |
|  <p>UA16-30-10R UA26-30-10R</p> | |  <p>UA30-30-10R</p> | |  <p>UA16/26/30-30-10R</p> | |  <p>UA50/63/75-30-00R</p> | |  <p>UA50/63/75-30-00R</p> | |
| <p>ZA...</p> <p>Uc = 24V~...690V~</p> <p>ZA16 → UA16...R ZA40 → UA26...R, UA30...R ZA75 → UA50...R, UA63...R, UA75...R</p> | |  <p>ZA16</p> | |  <p>ZA40</p> | |  <p>ZA75</p> | |  | |
| <p>UA16...R</p>  <p>RV 5 RC 5-1</p> <p>CAL 5-11 CA 5-01</p> | | | | <p>UA26...R</p>  <p>RV 5 RC 5-1</p> <p>CAL 5-11 CA 5-01</p> | | | | | |
| <p>UA30...R</p>  <p>RV 5 RC 5-1</p> <p>CAL 5-11 CA 5-01</p> | | | | <p>UA50/63/75...R</p>  <p>RV 5 RC 5-2</p> <p>CAL 5-11 2 x CA 5-01</p> | | | | | |

Warning! The operation, installation and servicing of this appliance must be carried out by a qualified electrician applying the relevant rules of the art, installation standards and safety regulations. Before operating the contactors, check that control voltage complies with the data on the coil mounting bracket. Connection to other control voltage can destroy the coil. Do not touch live parts. **Danger!**

Warnung! Die Inbetriebnahme und die Installation des vorhandenen Gerätes sowie jegliche Wartungsarbeiten müssen durch einen Fachelektriker, der die anerkannten technischen Regeln, die Montagevorschriften und die Sicherheitsvorschriften beachtet, durchgeführt werden. Vor Inbetriebnahme der Schütze prüfen ob Steuerspannung am Verwendungsort mit den aufgedruckten Spulendaten übereinstimmt. Der Anschluss einer anderen Steuerspannung kann zur Zerstörung der Spule führen. Spannung führende Teile nicht berühren. Lebensgefahr!

Attention! La mise en œuvre, l'installation de cet appareil et toute intervention doivent être effectuées par un électricien professionnel appliquant les règles de l'art, les normes d'installation et les règlements de sécurité. Avant la mise en marche des contacteurs, vérifiez que la tension du circuit de contrôle correspond bien aux indications de la bobine. Le raccordement d'une tension différente peut mener à une destruction de la bobine. Ne pas toucher les pièces sous tension. Danger de mort!

Varning! Igångsättning och installation av apparaten samt alla ingrepp bör utföras av en kompetent elektriker enligt alla konstens regler och gällande installationsnormer och säkerhetsregler. Kontrollera före installation av kontaktorn att aktuell manöverspänning överensstämmer med spolens märkdata. Felaktig manöverspänning kan skada spolen. Beröring av spänningsförande delar är förenat med livsfara.

Attenzione! La messa in opera, l'installazione di questo apparecchio ed ogni tipo di intervento devono essere effettuati da un elettricista professionista il quale applichi le regole del mestiere, le norme di installazione ed i regolamenti di sicurezza. Prima della messa in servizio del contattore, verificare che la tensione del circuito di comando corrisponda esattamente a quella indicata sulla bobina. L'alimentazione con una tensione diversa, può provocare la distruzione della bobina. Non toccare le parti attive. Pericolo di vita!

Atención! La puesta en aplicación, la instalación de este aparato y cualquier intervención deben realizarse por un electricista profesional que aplique las reglas del oficio, las normas de instalaciones y la reglamentación de seguridad. Antes de la puesta en servicio del contactor, comprobar si coinciden la tensión de mando con los datos impresos en la bobina. La conexión de otra tensión de mando puede producir la destrucción de la bobina. Las partes bajo tensión no deben tocarse. Peligro de muerte!

UA16...R
UA26...R
UA30...R
UA50...R
UA63...R
UA75...R

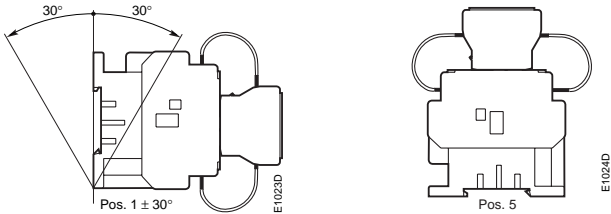
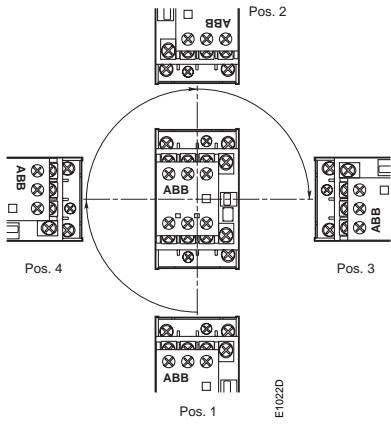

UA16...R . . . UA75...R

UA16...R . . . UA75...R

(mm)

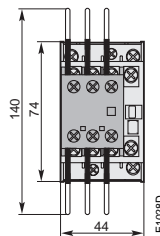

UA16...R

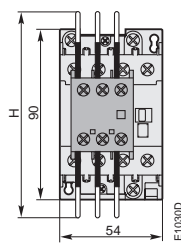

UA26...R, UA30...R

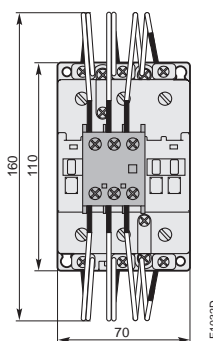

UA50...R, UA63...R, UA75...R

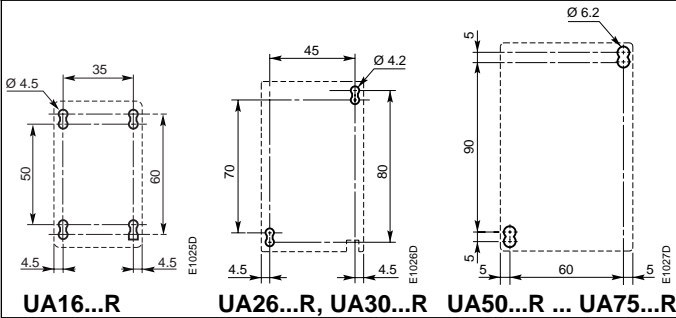
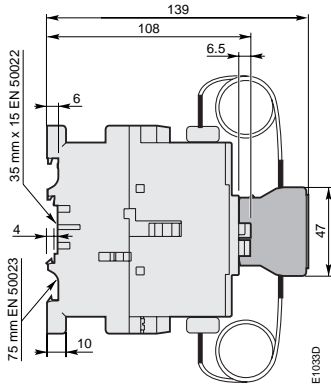
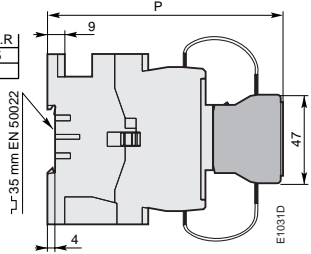
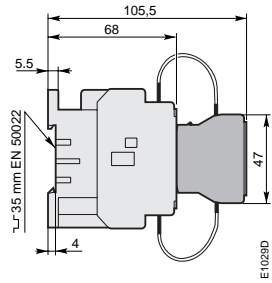

UA16...R

UA26...R, UA30...R

UA50...R ... UA75...R

| UA16...R | M 3,5 1 N.m | Ø 5,5 | pozidriv N°2 | 1 x 1...4 | 1 x 0,75...2,5 | UA16...R UA26...R UA30...R UA50...R UA63...R UA75...R | M 3,5 1 N.m | Ø 5,5 | pozidriv N°2 | 2 x 1...4 | 2 x 0,75...2,5 | $\begin{matrix} / > 3,5 \\ L < 8 \end{matrix}$ | |
|----------------------------------|----------------|-------|-----------------|--|--|--|----------------------|----------------|-----------------|--------------|-------------------|--|---|
| UA26...R | M 4 1,7 N.m | Ø 5,5 | | 1 x 1,5...6 | 1 x 1...4 | | UA16...R UA30...R | M 4 1,7 N.m | Ø 6,5 | — | 2 x 1...4 | 2 x 0,75...4 | $\begin{matrix} / > 4 \\ L < 10 \end{matrix}$ |
| UA30...R | M 5 2,3 N.m | Ø 6,5 | | 1 x 2,5...16 + 1 x 2,5...6 | 1 x 2,5...10 + 1 x 2,5...4 | | UA16...R UA30...R | | | | | | |
| UA50...R UA63...R UA75...R | M 8 4 N.m | Ø 6,5 | | 1 x 6...50 + 1 x 6...25 + 1 x 6...16 | 1 x 6...35 + 1 x 6...16 + 1 x 6...10 | | | | | | | | |

Don't remove the resistance wires when connecting the contactor.

Widerstandsdrähte nicht abklemmen beim Verdrahten des Schützes.

Ne pas déconnecter les résistances lors du raccordement du contacteur.

Ta inte bort motståndskablarna vid anslutning ar kontaktorn.

Non sconnettere le resistenze durante il raccordamento del contattore.

No desconectar las resistencias cuando se conecta el contactor.

Changing the main contacts: NOT ALLOWED

Kontaktaustausch: NICHT ERLAUBT

Changement des pôles: NON AUTORISE

Huvudkontakter: FAR EJ BYTAS

Sostituzione dei contatti: NON ANMESSA

Cambio de contactos: PROHIBIDO

