

**ABB STOTZ-KONTAKT GmbH**  
 Eppelheimer Str. 82 Postfach 10 1680  
 69123 Heidelberg 69006 Heidelberg  
 Germany Germany  
 Telephone +49 (0) 6221 701-0  
 Telefax +49 (0) 6221 701-240  
 E-mail desst.info@de.abb.com  
 Internet http://www.abb.de/stotz-kontakt

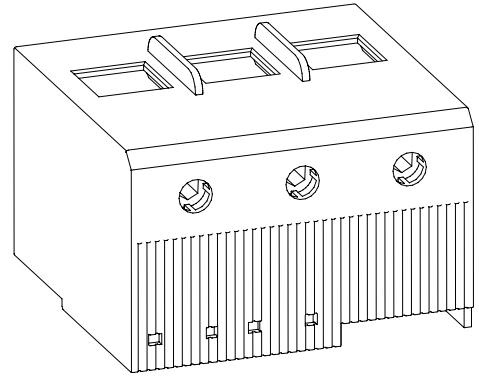

**Warnung!**

de Die Installation und Wartungsarbeiten dieses Gerätes müssen durch eine Elektrofachkraft durchgeführt werden, nach den anerkannten technischen Regeln, Vorschriften und relevanten Normen z. B. EN 60204 Teil 1.



**Avertissement!**

fr L'installation et la maintenance de cet appareil doivent être réalisées par des personnes compétentes et connaissant les textes et directives réglementaires, ainsi que les normes de référence telle que la norme EN60204.1.



**Avvertenze!**

it L'installazione e la manutenzione devono essere realizzate in accordo con le normative tecniche vigenti (esempio: EN60204-1) solamente da personale specializzato.



**Warning!**

en Installation and maintenance have to be performed according to the technical rules, codes and relevant standards, e.g. EN 60204 part 1, by skilled electricians only.



**Warning!**

sv Installation och underhåll av denna apparat får endast utföras av behörig person, och enligt gällande föreskrifter och standarder t.ex. EN 60204 del 1.



**¡Advertencia!**

es La instalación y mantenimiento de estos aparatos debe efectuarla un especialista, de acuerdo a las reglas, instrucciones y normas relevantes, p.ej.: EN60204, Parte 1.

de Anbauteil für Einzelaufstellung für Elektronisches Überlastrelais E80DU  
 en Mounting kit for single mounting of electronic overload relay E80DU  
 fr Kit de montage indépendant pour relais électronique de surcharge E80DU  
 sv Sockel för separat montering av Elektroniskt överlastrelä E80DU  
 it Kit per il montaggio separato del relè elettronico di sovraccarico E80DU  
 es Kit para Montaje separado del Rele de Sobrecarga electronico E80DU

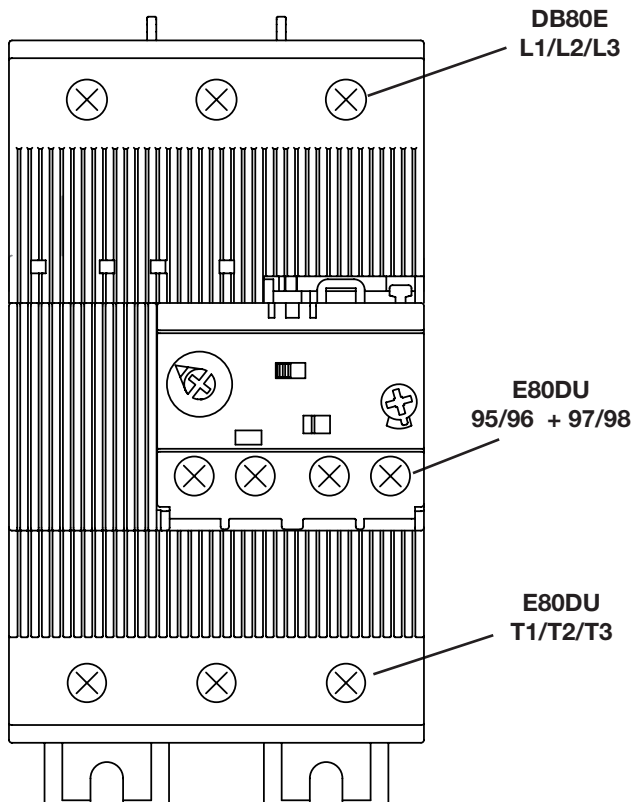
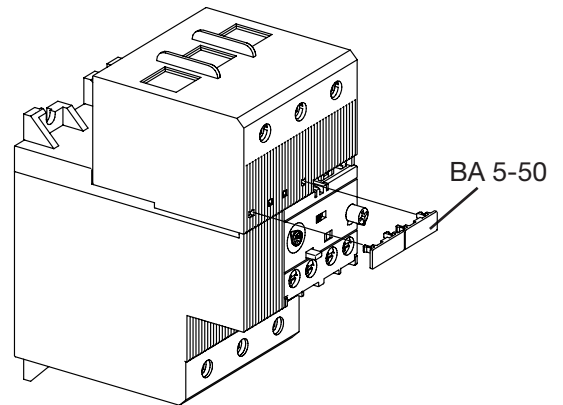

de Einbaulage: beliebig  
 en Mounting position: as required  
 fr Position de montage: quelconque  
 sv Monteringsposition: valfri  
 it Posizione di montaggio: qualsiasi  
 es Posición de montaje: cualquiera

	<b>DB80E L1/L2/L3</b>	<b>E80DU 95/96 + 97/98</b>	<b>E80DU T1/T2/T3</b>
	M8 Inbus 4 6,0 ... 6,5 Nm 53 lb.in	M3,5 Pozidriv 2 0,8 ... 1,0 Nm 7 lb.in	M8 Inbus 4 6,0 ... 6,5 Nm 53 lb.in
	1 x AWG 8 ... 000 2 x AWG 10 ... 2 1 x 10,0 ... 95 mm <sup>2</sup> 2 x 6,0 ... 35 mm <sup>2</sup>	1 x AWG 16 ... 12 2 x AWG 16 ... 12 1 x 1,0 ... 4 mm <sup>2</sup> 2 x 1,0 ... 4 mm <sup>2</sup>	1 x AWG 8 ... 000 2 x AWG 10 ... 2 1 x 10,0 ... 95 mm <sup>2</sup> 2 x 6,0 ... 35 mm <sup>2</sup>
	1 x AWG 8 ... 000 2 x AWG 10 ... 2 1 x 10,0 ... 70 mm <sup>2</sup> 2 x 6,0 ... 35 mm <sup>2</sup>	1 x AWG 18 ... 14 2 x AWG 18 ... 14 1 x 0,75 ... 2,5 2 x 0,75 ... 2,5	1 x AWG 8 ... 000 2 x AWG 10 ... 2 1 x 10,0 ... 70 mm <sup>2</sup> 2 x 6,0 ... 35 mm <sup>2</sup>

