

TEIP11

I/P signal converter for standard signals



Current in air pressure

Proven and reliable concept

Compact design

- Small dimensions, low weight

Sturdy construction and solid functionality

- Influence of shock and vibration < 1% at 10 g

Variety of signal ranges

- Input, e.g., 0 ... 20 mA or 4 ... 20 mA
- Output 0.2 ... 1 bar (3 ... 15 psi)

Additional temperature range

- From -40 (optional -55) ... 85 °C
(-40 (optional -67) ... 185 °F)

Ex protection approvals

- ATEX, FM/CSA, GOST for intrinsically safe and Explosion proof operation

Several different designs

- IP 20 control room housing unit for rail mounting
- IP 20 control room housing unit for block mounting
- IP 54 plastic field housing unit
- IP 65 aluminum or stainless steel housing unit

Single module

- For OEM application (upon request)

Contents

1	Concept	3
2	Technical data	3
2.1	Input (electric)	3
2.2	Output (pneumatic)	3
2.3	Power supply (pneumatic)	3
2.4	Transmission data and influences	3
2.5	Explosion protection	4
2.6	Environmental capabilities	4
2.7	Design for rail mounting	4
2.8	Design for field-mount housing (aluminum / stainless steel)	5
2.9	Accessories	5
2.10	Spare parts	5
2.11	Dimensioned drawings	5
3	Ordering information	8
3.1	Additional ordering information	8
3.2	Order information, accessories	8

1 Concept

The TEIP11 signal converter transforms electrical signals, e.g., 4 ... 20 mA in 0.2 ... 1 bar (3 ... 15 psi). It is therefore a connecting link between electrical/electronic and pneumatic systems. The signal conversion process is similar to the patented force balance method.

Special features of the TEIP11 signal converter are its relatively small dimensions and outstanding operational stability when subject to shock and vibration. The converter can be subjected to loads up to 10 g with less than 1% effect on function.

The housing units are available in a variety of models to meet your installation requirements. For potentially explosive conditions, units that offer intrinsically safe operation or Explosion proof encapsulation are available with international approval certificates for use worldwide.

A variety of signal conversion ranges are available on the input and output sides (see chapter **Technical data**, page 3) For auxiliary power, compressed air at 1.4 bar (20 psi) may be required.

2 Technical data

2.1 Input (electric)

Signal range

0 ... 20 mA or 4 ... 20 mA
 0 ... 10 mA or 10 ... 20 mA
 4 ... 12 mA or 12 ... 20 mA

(additional ranges available upon request)

Input resistance

$R_i = 260 \Omega$ at 20 °C (68 °F), $T_k + 0.4 \text{ %/K}$

Overload limit

30 mA (see specifications "Explosion protection" for Ex devices)

Capacitance/Inductance

negligible

2.2 Output (pneumatic)

Signal range

0.2 ... 1 bar (3 ... 15 psi)

Air capacity

at supply air pressure	kg/h	Nm ³ /h	scfm
1,4 bar (20 psi)	0,05	0,041	0,024
2,0 bar (30 psi)	0,07	0,057	0,033
4,0 bar (60 psi)	0,10	0,082	0,048
6,0 bar (90 psi)	0,16	0,130	0,076
10,0 bar (150 psi)	0,25	0,205	0,120

2.3 Power supply (pneumatic)

Instrument air

free of oil, water and dust acc. to DIN/ISO 8573-1
 pollution and oil content according to Class 3
 Pressure dew point 10 K below operating temperature

Supply pressure

1.4 ... 10 bar (20 ... 150 psi)

Air consumption

equivalent to air capacity

2.4 Transmission data and influences

Characteristic

linear, direct or reverse action

Deviation

$\leq 1 \text{ %}$

Hysteresis

$\leq 0,3 \text{ %}$

Dead band

$\leq 0,1 \text{ %}$

Temperature

$\leq 0.1 \text{ %} / 10 \text{ K}$ within -20 ... 85 °C (-4 ... 185 °F)

$\leq 0.2 \text{ %} / 10 \text{ K}$ within -55 ... -20 °C (-67 ... -4 °F)

Influence of supply air pressure

$\leq 0.8 \text{ %}$ at 1.4 ... 2 bar (20 ... 30 psi)

$\leq 0.8 \text{ %}$ at 2 ... 3 bar (30 ... 45 psi)

$\leq 0.5 \text{ %}$ at 3 ... 10 bar (45 ... 150 psi for every 1 bar (15 psi))

Mechanical vibration

$\leq 1 \text{ %}$ to 10 g and 20 ... 80 Hz

Seismic vibration

Meets requirements of DIN / IEC 68-3-3 Class III for strong and strongest earthquakes.

Mounting orientation

Zero point $\leq 0.5 \text{ %}$ at 90° change of position

EMC

meets EMC directive 89/336/EEC as of May 1989 (increased EMI shielding per EN 50082-2 PR as of 11/93)

CE mark

complies with EC directive for CE certificate of conformity

2.5 Explosion protection

Explosion protection

ATEX / GOST Russia / GOST Ukraine, intrinsically safe (all designs)

2G EEx ia IIC /T4/T5/T6 TÜV 1487x (for the control room housing and field housing unit)

ATEX / GOST Russia / GOST Ukraine, flameproof (metal field housing only)

EEx d IIC T4/T5/T6

Thermal specifications for explosion protection class Ex ia

(doc no. 901068 or doc no. 901069)

The following limit values for the temperature classes must be observed for the intrinsically safe versions:

Temperature class	Input current	Ambient temp.
T6	50 mA	-55 ... 60 °C (-67 ... 140 °F)
T6	60 mA	-55 ... 55 °C (-67 ... 131 °F)
T5	60 mA	-55 ... 70 °C (-67 ... 158 °F)
T4	60 mA	-55 ... 85 °C (-67 ... 185 °F)
T5	100 mA	-55 ... 55 °C (-67 ... 131 °F)
T4	100 mA	-55 ... 85 °C (-67 ... 185 °F)
T5	120 mA	-55 ... 45 °C (-67 ... 113 °F)
T4	120 mA	-55 ... 80 °C (-67 ... 176 °F)
T4	150 mA	-55 ... 70 °C (-67 ... 158 °F)

Thermal specifications for explosion protection class Ex d

The following limit values for the temperature classes must be observed for Ex d versions (doc. no. 900771):

Temperature class	Input current	Ambient temp.
T6	50 mA	-40 ... 55 °C (-40 ... 131 °F)
T5	50 mA	-40 ... 70 °C (-40 ... 158 °F)
T4	40 mA	-40 ... 85 °C (-40 ... 185 °F)

FM "intrinsically safe" (not for metal field housing units)

I.S.: CL I / Div 1 / Grp A B C D

N.I.: CL I / Div 2 / Grp A B C D

FM "intrinsically safe" (for metal field housing units only)

I.S.: CL I-II-II / Div 1 / Grp A B C D E F G

N.I.: CL I / Div 2 / Grp A B C

S.: CL II / Div 2 / Grp G

S.: CL III / Div 2

FM "explosion proof" (for metal field housing units only)

X.P.: CL I / Div 1 / Grp A B C D

D.I.P.: CL II III / Div 2 / Grp E F G

CSA "intrinsically safe" (not for metal field housing units)

I.S.: CL I / Div 1 / Grp A B C D

CL I / Div 2 / Grp A B C D

CSA "intrinsically safe" (for metal field housing units only)

I.S.: CL I / Div 1 / Grp A B C D

CL II / Div 1 / Grp E F G

CL III

CL I / Div 2 / Grp A B C D

CL II / Div 2 / Grp E F G

CSA "explosion proof" (for metal field housing units only)

IX.P.: CL I / Div 1 / Grp B C D

CL II / Div 2 / Grp E F G

Gost

Explosion protection requirements

ATEX EEx ia or EEx d

FM/CSA intrinsically safe

FM/CSA explosion proof

GOST EEx ia or EEx d (Russia / Ukraine)

Other explosion protection certificates on request

2.6 Environmental capabilities

Climate class

GPF or FPF acc. to DIN 40040

Temperature -55 ... 85 °C (-67 ... 185 °F)

-45 ... 85 °C (-49 ... 185 °F)

for operation, storage or transport

Relative humidity 75 % mean, 95 % short-term

no condensation

2.7 Design for rail mounting

Material/protection

Housing IP 20

aluminum with plastic cap

Mounting

Rail mounting EN 50022 - 35 x 7,5

EN 50035 - G 32

EN 50045 - 15 x 5

Electrical connection

2-pole screw terminal for 2.5 mm² (14 AWG)

Pneumatic connection

two 1/8 NPT threads for air supply and output

Weight

0,25 kg (0.55 lb)

Dimensions

Refer to dimensioned drawings

2.8 Design for field-mount housing (aluminum / stainless steel)

Material/protection

Aluminum or stainless steel housing IP 65

Surface

Aluminum housing
 painted with dual component coating
 Lower section, black, RAL 9005
 Screw-on cap Pantone 420

Stainless steel housing
 electrolytically polished

Mounting

Wall mount or 2" pipe installation
 With stainless steel mounting bracket (accessory)

Electrical connection

2-pole screw terminal for 2.5 mm² (14 AWG) in housing,
 Cable gland NPT 1/2" for cable entry

for ATEX intrinsically safe
 Threads M20 x 1.5 for cable entry

for ATEX EEx d:
 (on request cable gland with Ex d certificate as accessory)
 Cable entry NPT 1/2" for cable entry with FM/CSA

Pneumatic connection

1/4" NPT threads for air supply and output

Weight

0.62 kg (1.37 lb) with aluminum housing
 1.20 kg (2.65 lb) with stainless steel housing

Dimensions

Refer to dimensioned drawings

2.9 Accessories

Cable gland EEx d

brass, with M20 x 1.5 threads

Mounting angle of stainless steel for wall or 2" pipe installation

for aluminum or stainless steel field housing unit

Material for block mounting

Connection block for 4 converters
 Dummy panel with central air connector 3/8 NPT
 Dummy panel

2.10 Spare parts

Except for the textile filter, the signal converter is wear free and does not require maintenance.

2.11 Dimensioned drawings

2.11.1 Design for control room housing unit for rail mounting

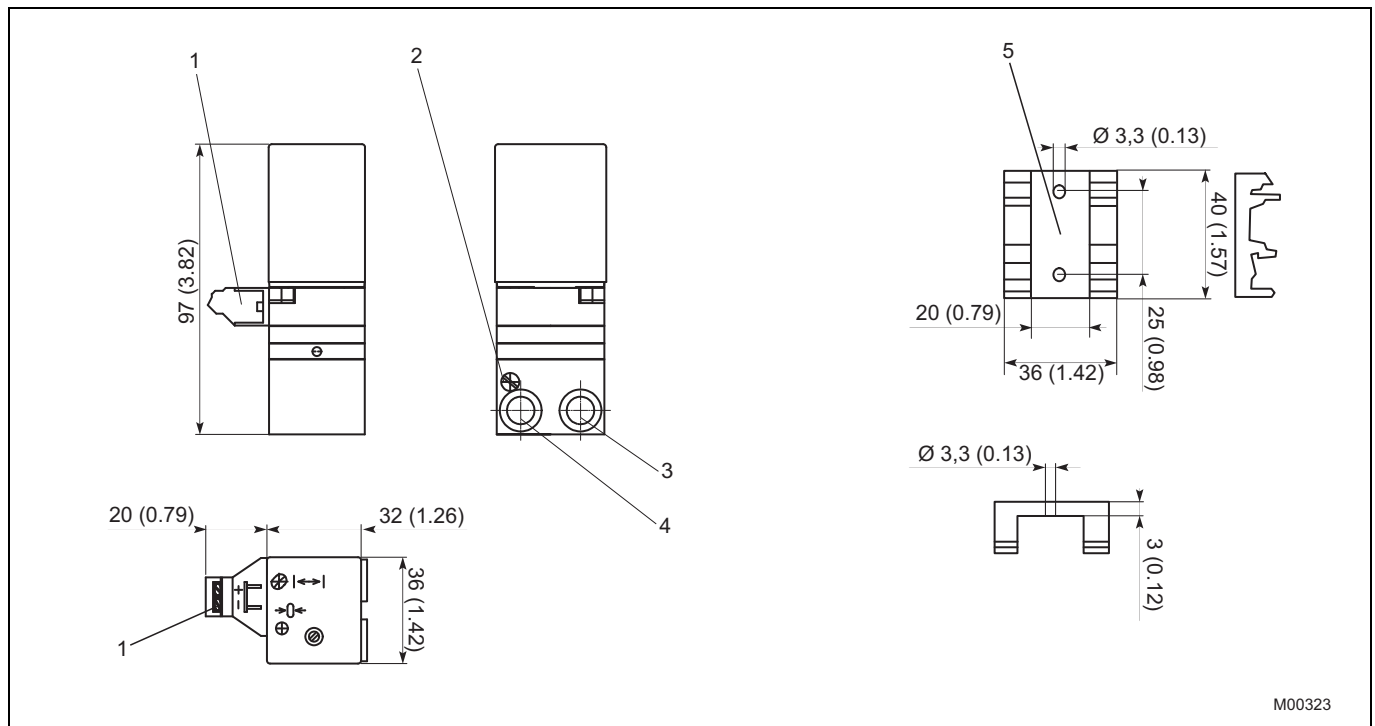
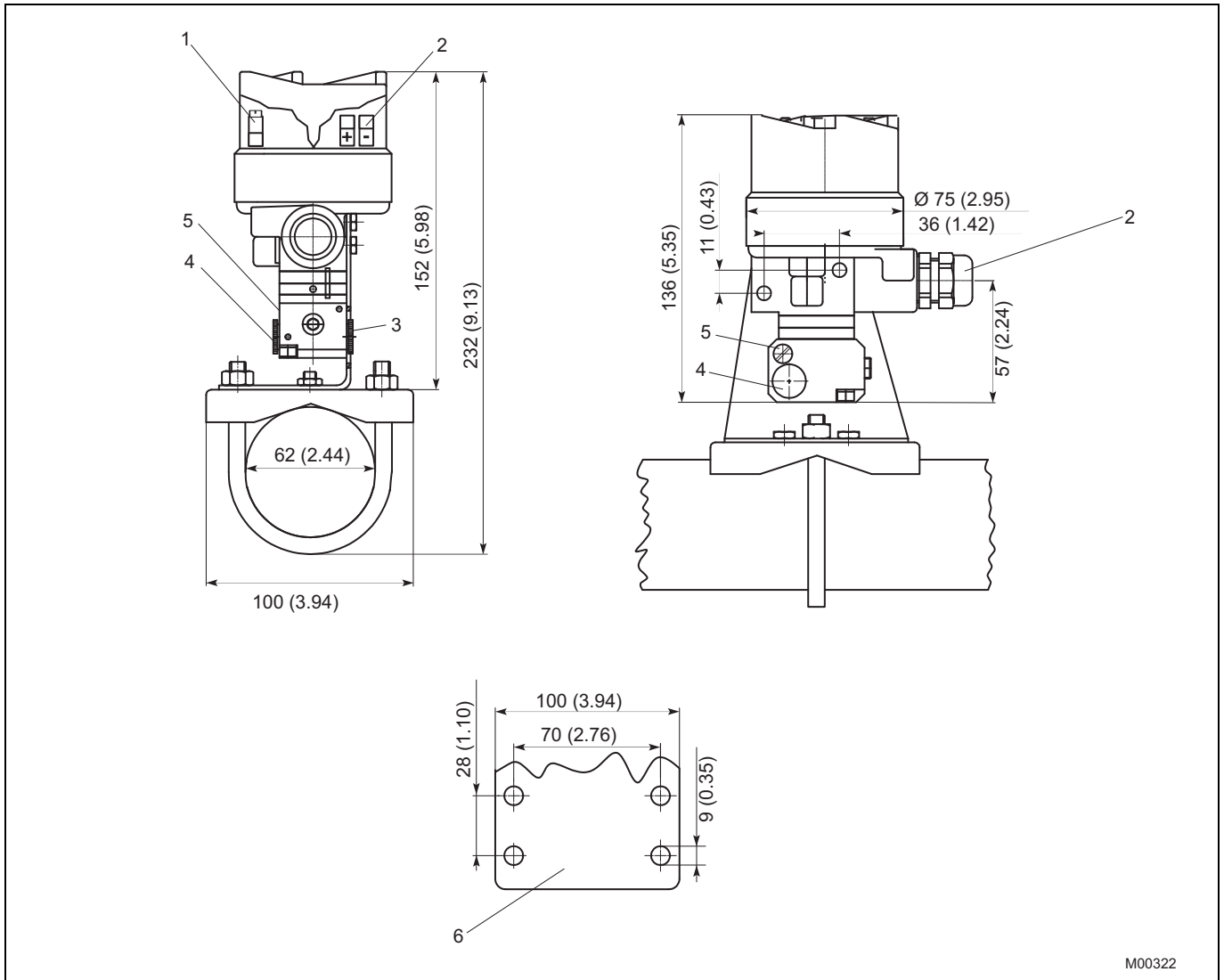

Fig. 1: Dimensions in mm (inch)

- | | |
|--------------------------|----------------------------------|
| 1 Electrical connections | 4 Supply air |
| 2 Filter | 5 Mounting bracket for DIN rails |
| 3 Output | |

2.11.2 Aluminum or stainless steel field-mount housing unit



M00322

Fig. 2: Dimensions in mm (inch)

- | | | | |
|---|------------------------|---|----------------------------------|
| 1 | Ground terminals | 4 | Supply air |
| 2 | Electrical connections | 5 | Filter |
| 3 | Output | 6 | Profiled sheet for wall mounting |

2.11.3 Field housing unit as mounting module for OEM applications

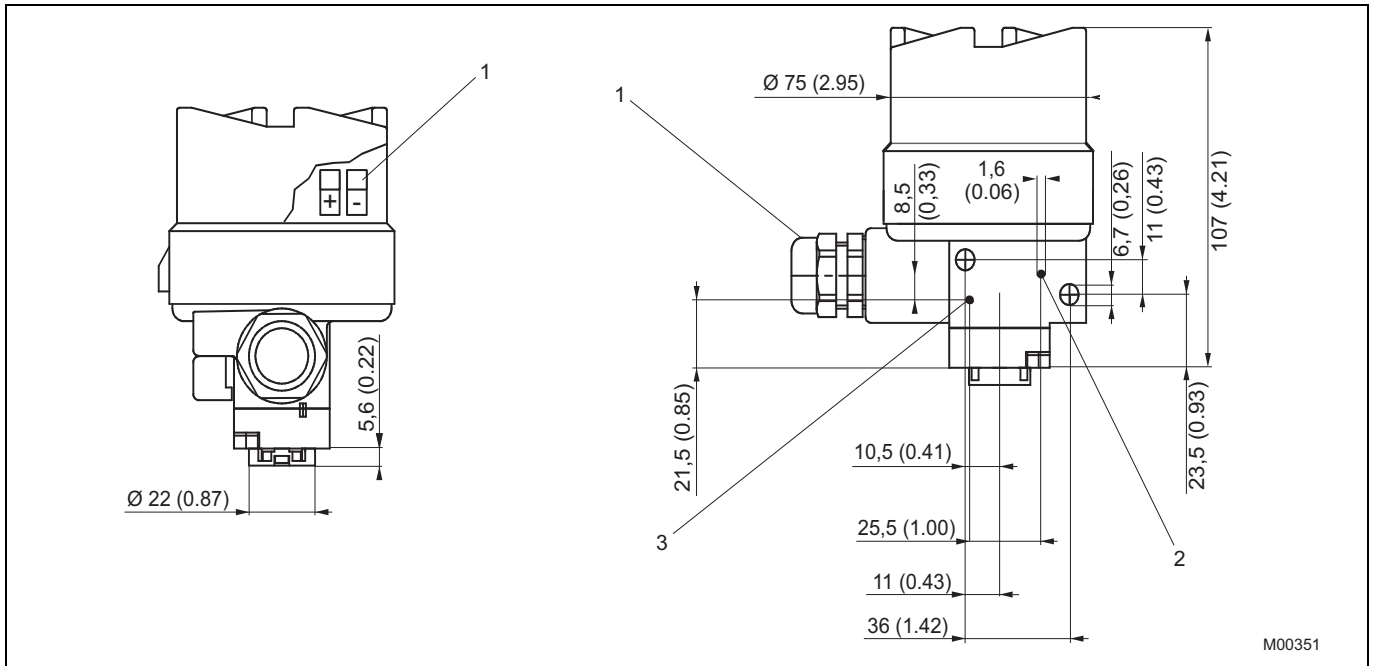

Fig. 3: Dimensions in mm (inch)

- 1 Electrical connections
- 2 Output
- 3 Supply air

M00351

3 Ordering information

I/P Converter TEIP11	Variant digit No.	1	2	3	4	5	6	7	8	Code			
	Catalog No.	V18312H-											
Explosion protection													
Standard (without explosion protection)		1											
ATEX EEx ia IIC		2											
ATEX EEx d IIC		3											
FM/CSA approval for "intrinsically safe"		5											
FM/CSA approval for "intrinsically safe" and "explosion proof"		6											
Design													
Control room housing, IP 20 for rail mounting		1											
Aluminum field housing, IP 65 for wall or pipe mounting		2											
Aluminum field housing, IP 65 add-on module for OEM applications		3											
Stainless steel field housing, IP 65 for wall or pipe mounting		4											
Stainless steel field housing, IP 65 add-on module for OEM applications		5											
Input signal													
0 ... 20 mA		1											
4 ... 20 mA		2											
Output signal													
0.2 ... 1 bar				1									
3 ... 15 psi				2									
Characteristic													
Direct action						1							
Reverse action						2							
Ambient temperature													
-40 ... +85 °C						1							
-55 ... +85 °C						2							
Air supply (air pressure)													
Adjusted to 1.4 bar								1					
3 bar								2					
4 bar								3					
5 bar								4					
as specified (plain text)								9					
Design (varnish / label)													
Standard (OEM-specific upon request)										0			

3.1 Additional ordering information

	Code			
Certificate of compliance				
Certificate of compliance with the order acc. to EN 10204-2.1 (DIN 50049-2.1)	CF1			
Certificate of compliance with the order acc. to EN 10204-2.1 (DIN 50049-2.1) with item description	CF2			
Test Report acc. to EN 10204-2.2 (DIN 50049-2.2)	CF3			
Inspection certificate				
Inspection Certificate 3.1 acc. to EN 10204 with max. deviation	CBA			

3.2 Order information, accessories

	Catalog No.	Code		
Cable gland EEx d, brass, M 20x1.5 thread	319343			
Mounting bracket, stainless steel for wall mounting	319344			
for wall or 2" pipe mounting	319345			
(for mounting the aluminium or stainless steel field housing)				

1) not with control room housing IP 20

2) only with control room housing IP 20

Contact us

ABB Ltd.

Process Automation

Salterbeck Trading Estate
Workington, Cumbria
CA14 5DS
UK

Phone: +44 (0)1946 830 611

Fax: +44 (0)1946 832 661

ABB Inc.

Process Automation

125 E. County Line Road
Warminster, PA 18974
USA

Phone: +1 215 674 6000

Fax: +1 215 674 7183

ABB Automation Products GmbH

Process Automation

Schillerstr. 72
32425 Minden
Germany

Phone: +49 551 905-534

Fax: +49 551 905-555

www.abb.com

Note

We reserve the right to make technical changes or modify the contents of this document without prior notice. With regard to purchase orders, the agreed particulars shall prevail. ABB does not accept any responsibility whatsoever for potential errors or possible lack of information in this document.

We reserve all rights in this document and in the subject matter and illustrations contained therein. Any reproduction, disclosure to third parties or utilization of its contents - in whole or in parts - is forbidden without prior written consent of ABB.

Copyright© 2010 ABB

All rights reserved