

Instrumentation solutions

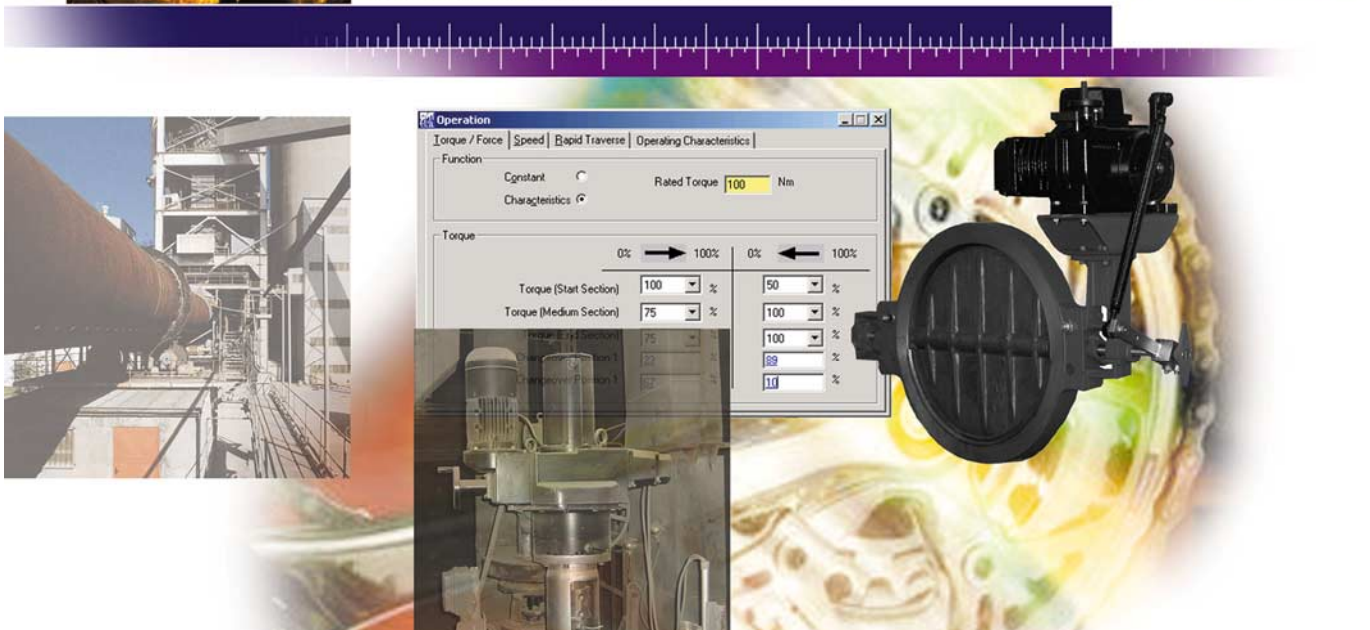

- Electrical actuators for positioning vanes and valves in the process control loop
- Combining durability and precision positioning
- Suitable for continuous positioning and three-step control

1	General	3
2	Operating principles	5
3	Devices	8
3.1	Part-turn actuators.....	8
3.2	Linear actuators.....	9
3.3	Power electronic units	11
3.4	Electrical connection	12
4	Communication	15
4.1	FSK.....	15
4.2	RS 232.....	16
4.3	Fieldbus.....	17
5	Software	18
5.1	Device software.....	18
5.2	Engineering software.....	19
5.3	Configuration software	20
6	Functions	21
6.1	Basic setup.....	21
6.2	Configuration	22
6.2.1	Operating mode	22
6.2.2	Torque/force.....	23
6.2.3	Speed.....	23
6.2.4	Driving into end position.....	23
6.2.5	Leaving the end position	24
6.2.6	Avoiding movements near the end position.....	24
6.2.7	Inputs/outputs.....	24
6.2.8	Monitoring.....	25
6.3	Service.....	26
6.3.1	Test	26
6.3.2	Signal simulation	26
6.4	Diagnostics.....	27
6.4.1	Status	27
6.4.2	Alarms/Errors	27
6.4.3	Maintenance.....	28
6.4.4	Load	28
6.4.5	Recording.....	28
6.4.6	Integrated PID controller	28
7	Actuator with explosion-proof design	29
8	Installation examples	31

1 General

Actuators are used in every industrial sector. In the field of process automation, they are responsible for positioning vanes and valves, etc. to control the flow of material, mass, and energy.

The trend towards actuators as "intelligent field devices" is now considered to be part of the state of the art. The recent past has seen an increase in demands for functions to be incorporated within devices, as well as for connectability to bus systems and visualization of process and device data.



Fig. 1: Jänschwalde power plant, Cottbus (Germany)

CONTRAC has been developed to satisfy these demands. CONTRAC, a composite term based on the words control and actuator, is an "intelligent" and compact actuator. The Contrac actuator system is based on the family of rotary and linear actuators which has a sound track record reaching back 50 years or more.

Its features include:

- Continuous positioning
- Overload-proof at end positions without the need for torque dependent switch-off
- High protection class
- Long service intervals

A combination of proven mechanical components and microprocessor electronics have been used to develop an intelligent series of actuators which:

- Are compatible with fieldbuses as well as more traditional control methods
- Support diagnostics and can be parameterized via a graphic user interface
- Feature a self-monitoring facility
- Enable fail-safe storage of technical data

These actuators offer far more than the standard functions associated with such equipment. These new features take the form of actuator-specific functions, which ensure operational reliability and facilitate monitoring, maintenance, and service.

In addition to the wealth of functions offered, the three-phase asynchronous motor with its cage rotor is one of the actuator's key components. This motor was chosen as reliability and operational safety are just as important for the new generation of actuators as they always were. We were also aware that this motor's straightforward design and proven durability and reliability had helped it deliver successful solutions in many actuator applications over a number of decades and all over the world.

The breakthrough of frequency convertor technology in the early 1980s opened the door to even greater success for three-phase asynchronous motors. Three-phase motors could now be used for speed control, an area which had previously been the preserve of DC motors.

Not only that, but frequency converters made it possible to vary the torque and stroke time of an intelligent actuator, with the option of adapting either of these parameters, independently of one other, to the control element or the process.

2 Operating principles

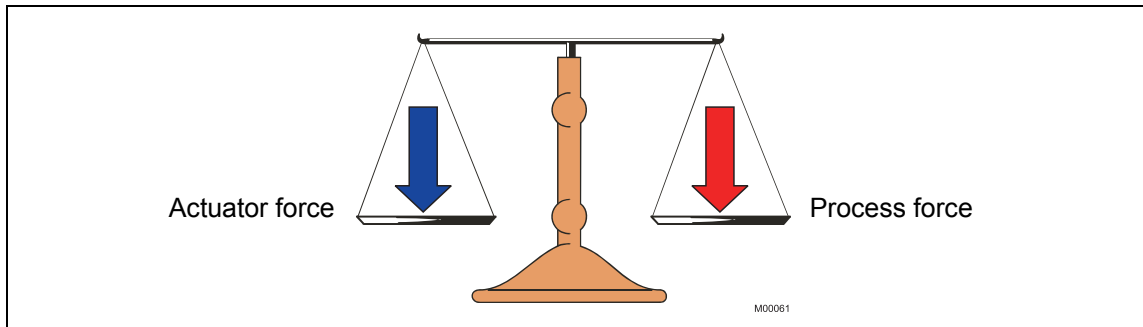

Fig. 2: Operating principles

The actuator continuously responds to a setpoint signal. The motor is constantly under voltage (operating mode S9 – 100 % stallproof according to IEC 60034-1 / EN 60034-1) and gently increases or reduces the torque on the electronic unit in proportion to the ΔY signal (the difference between the Y setpoint and the Y position signal - see Fig. 4). The actuator is not subject to any temperature derating, i. e., there are no restrictions, even at the maximum permissible ambient temperature. Where a state of balance exists, the actuator force and process force are equivalent and the actuator will keep the control element in the required position.

If such a "state of balance" applies, the ΔY value will be in the proportional area of the torque / force characteristic curve (see Fig. 4).

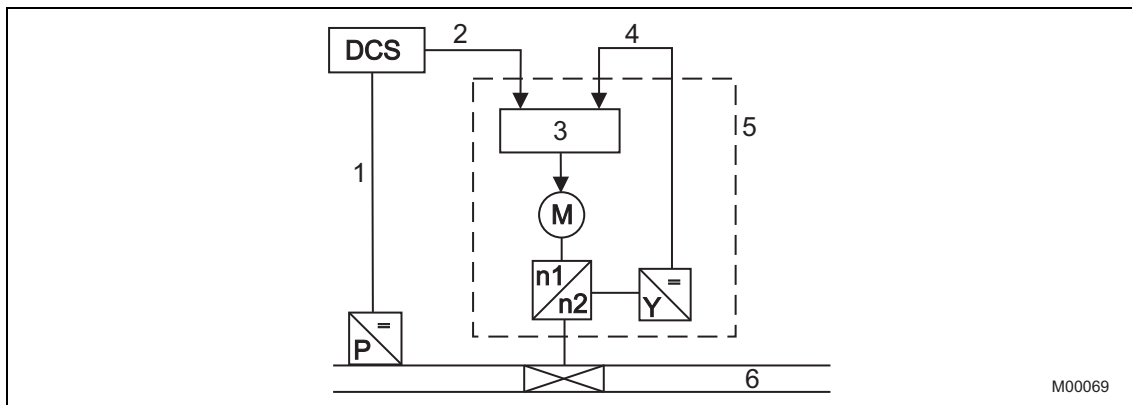

Fig. 3: Continuous positioning

- | | |
|---------------------|--------------------------------------|
| 1 Process data | 4 Y position signal |
| 2 Y setpoint signal | 5 Contrac (subordinate control loop) |
| 3 Electronic unit | 6 Process |

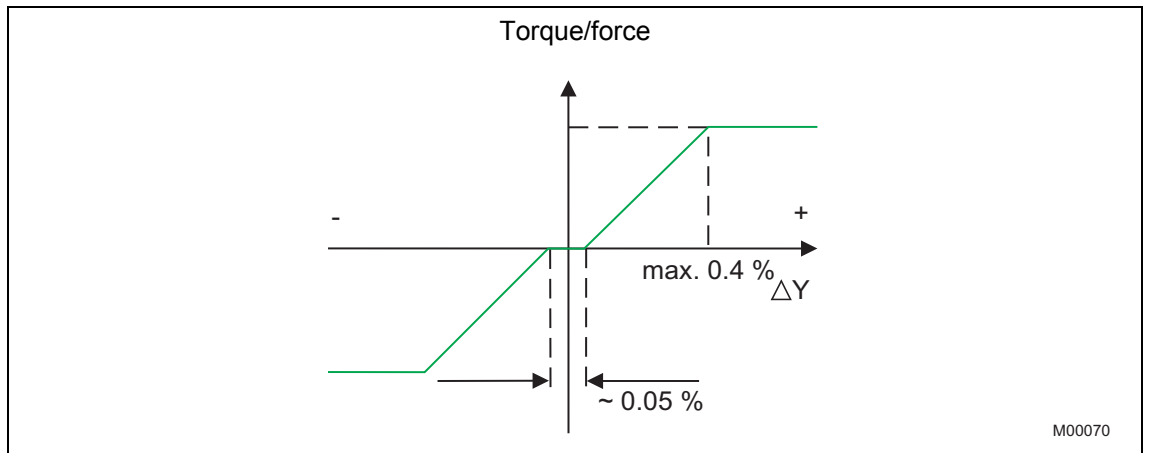

Fig. 4: Torque / force depending on position deviation

Fig. 5 shows the dynamic behavior of the Contrac after a setpoint change. The actuator follows the changing setpoint almost immediately, with only a slight delay.

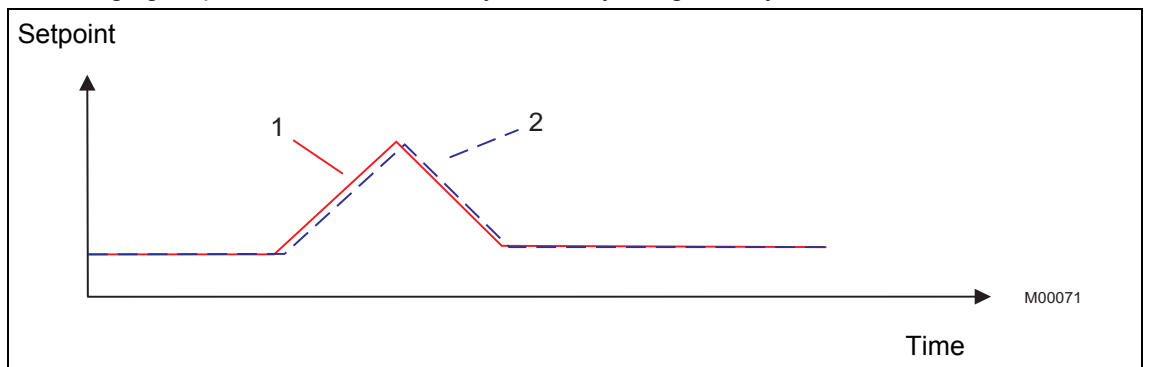

Fig. 5: Schematic representation of a Contrac step response

- 1 Position setpoint
- 2 Actuator position

Thanks to the special electronics and control technology used, no temperature / torque monitoring switches are required. This operating mode, with its gentle changes in mechanical load, is one of the reasons for the long service intervals.

If the power supply is interrupted, the motor will be in a dead-voltage state and a brake at the rear end of the motor shaft will stop the motor and the actuator and keep them in their current positions (closed circuit principle). This stops any restoring forces associated with the process moving the actuator to one of the end positions.

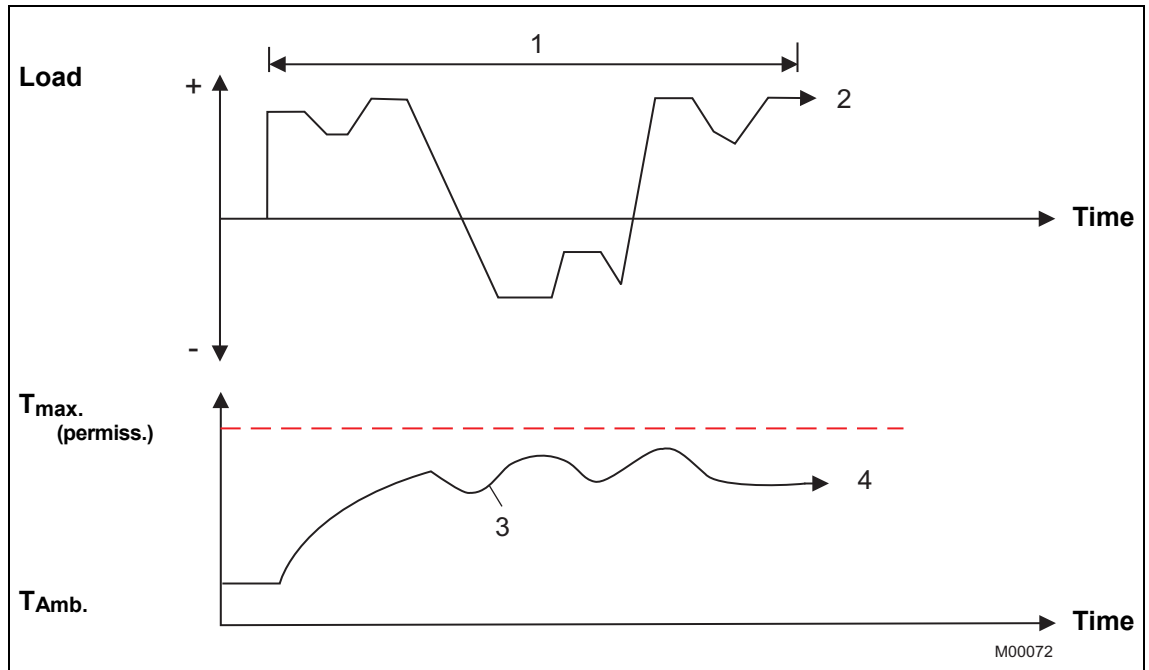

Fig. 6: Operating mode definition

- 1 Load cycle
- 2 Permanently switched on
- 3 $T_{max.}$ (device)
- 4 The device's steady-state temperature never exceeds the maximum permissible temperature.

S9 specification:

The device (the actuator in this case) is switched on and remains constantly under voltage. The temperature of the device rises after it has been switched on, but never exceeds the maximum permissible temperature limit. The device must be 100 % switched on, with no time limit applying to this state (even at the maximum permissible temperature and where there are changes in speed / direction of rotation) and with no protection or monitoring equipment in place.

Operating mode S1 (100 % operating time at constant load) is also covered under operating mode S9!

No restrictions are imposed on the control loop by the actuator!

3 Devices

3.1 Part-turn actuators

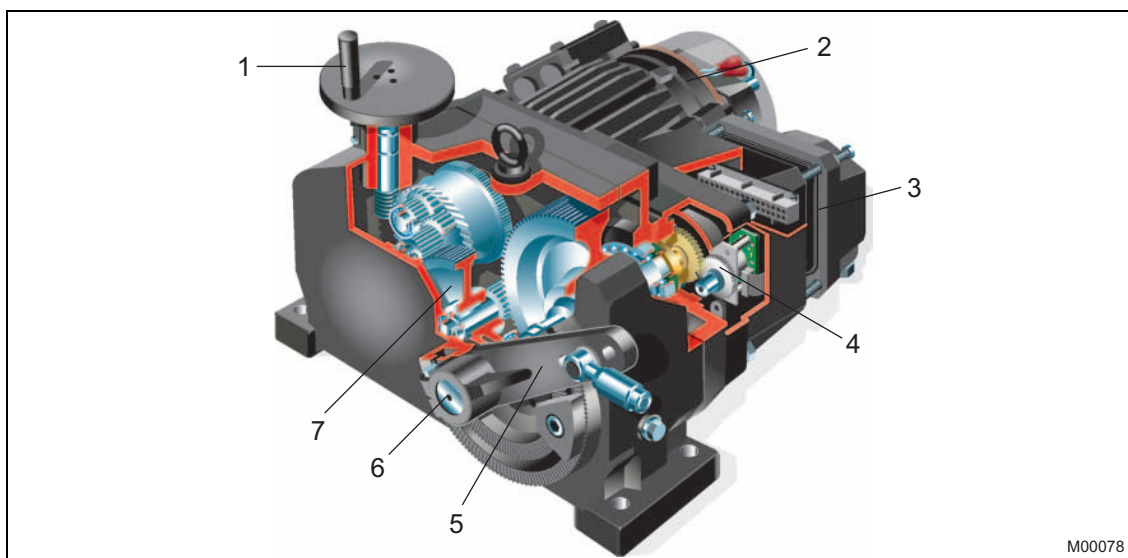

Fig. 7: Cross-section of a rotary actuator

- | | |
|----------------------------------|----------------|
| 1 Handwheel for manual operation | 5 Lever |
| 2 Motor | 6 Output shaft |
| 3 Plug for electrical connection | 7 Spur gearing |
| 4 Position sensor | |

Rotary actuators are available for rated torques of between 50 Nm and 16000 Nm (40 lbf-ft to 12000 lbf-ft) and all share a similar design. A motor drives low-friction, oil-lubricated spur gearing. At the end of this gearing, a lever mounted on the output shaft transmits torque to the control element via a rod. As the position sensor is mounted directly on the rear end of the output shaft, position feedback can be provided without any backlash. This is one of the reasons why Contrac is able to offer such high levels of positioning precision.



Fig. 8: Rotary actuator mounted on a vane



M00080

Fig. 9: Contrac actuators offer operational reliability, even under the most difficult conditions

3.2 Linear actuators

Linear actuators are available for rated forces in the range 4 ... 200 kN (900 ... 45000 lbf) and are also very similar in terms of their design. The motor drives the internal rotary / linear conversion module located on the thrust rod. This moves the thrust rod outwards or inwards, depending on the motor's direction of rotation. What sets Contrac linear actuators apart are the technical specifications relating to this rotary / linear conversion, whereby ABB uses a recirculating ball unit with extremely low friction.

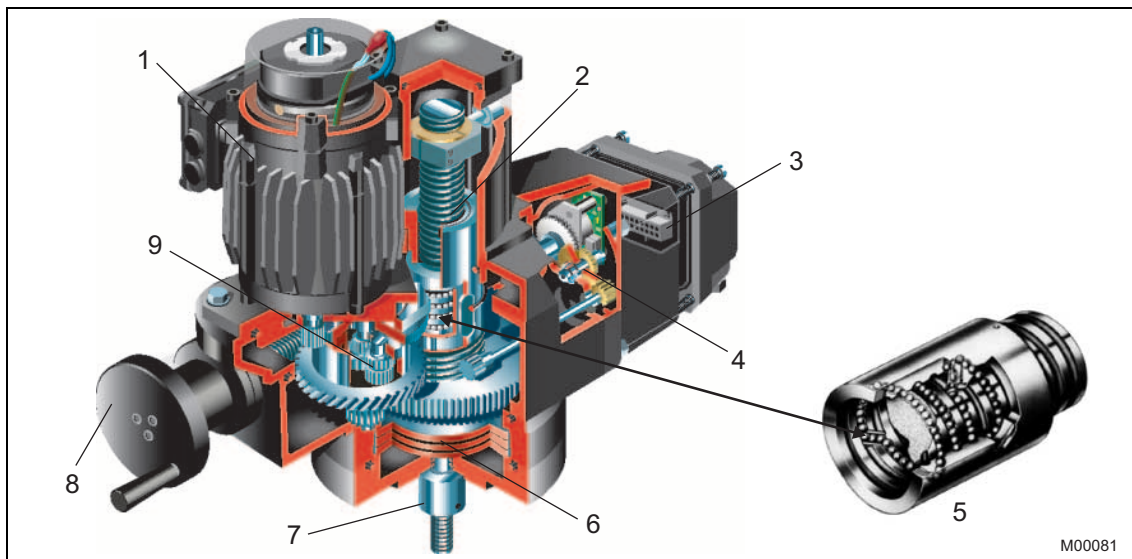

M00081

Fig. 10: Cross-section of a linear actuator and detailed view of the recirculating ball screw

- | | |
|-----------------------------------------|----------------------|
| 1 Motor | 6 Integrated springs |
| 2 Integrated rotary / linear conversion | 7 Thrust rod |
| 3 Plug for electrical connection | 8 Handwheel |
| 4 Position sensor | 9 Spur gearing |
| 5 Recirculating ball screw | |

Integrated springs absorb any peak loads which might occur when approaching the end positions for the valve. They also, however, absorb temperature-related alterations to the length of the thrust rod or valve stem (e. g. when mounting the actuator on a superheated steam pipe).



Fig. 11: RSD20 linear actuator

- 1 Actuator
- 2 Yoke
- 3 Valve

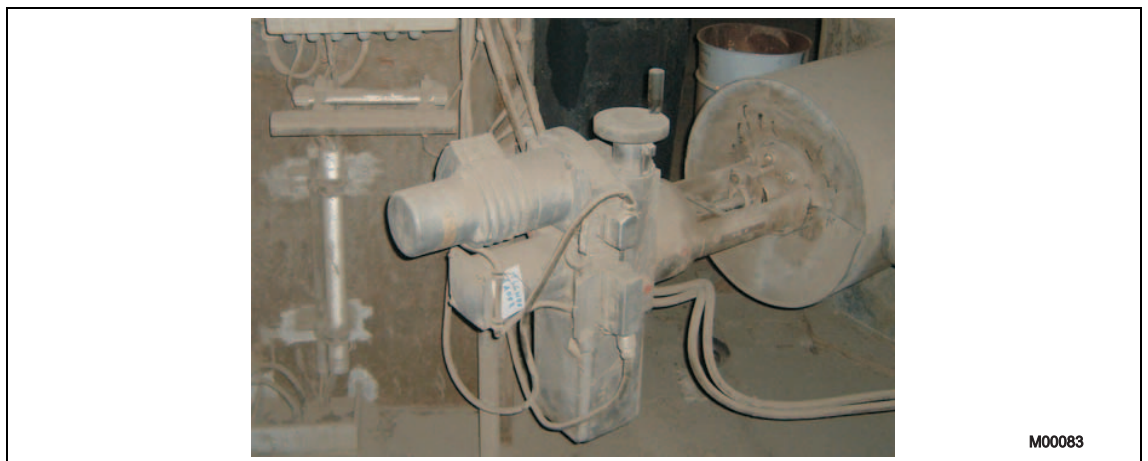

Fig. 12: Horizontally mounted linear actuator

3.3 Power electronic units

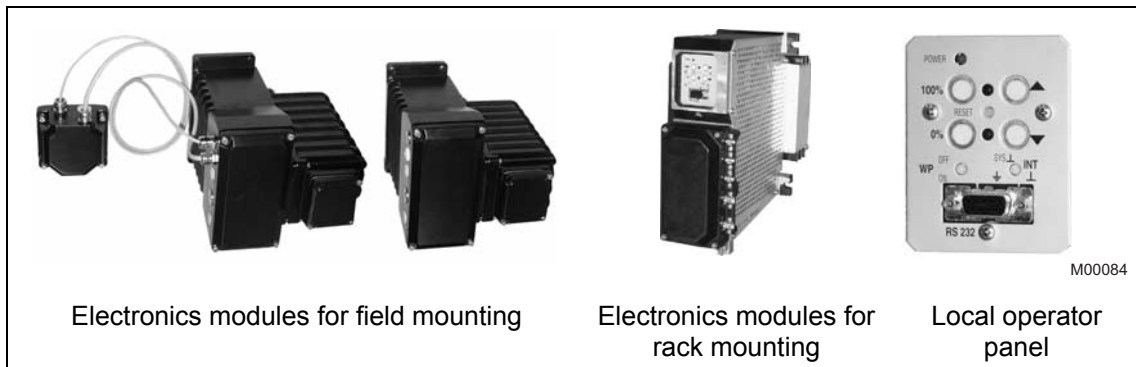

Fig. 13: Power electronic units; integrated version is available for the smallest rotary and linear actuators

If the actuator provides the muscles for a positioning loop, the power electronic units provide the brains. These modules can be installed in the field near the actuator (IP 66) or remotely in a mounting rack (IP 20). The integrated version is available for both the smallest rotary actuator and the smallest linear actuator.

In addition to the connection terminals, the following are also included: a microprocessor, a frequency converter for motor control, digital inputs and outputs, communication interfaces, and a female connector for connection to a PC, with local parameterization and diagnostics via a graphical user interface.

All power electronic units are supplied by the line supply (1~ AC 115 / 230 V), whatever the motor output of the associated actuator.



Fig. 14: Power electronic units for field mounting (example)

3.4 Electrical connection

As the connector housing is made of metal, this ensures a high protection class and reliable electrical connection, even under difficult ambient conditions. Depending on the option selected, there will be either 1 or 2 terminal blocks for connecting power and signal cables. These terminal blocks can be used for both screw and clamp-type terminals.

Actuator

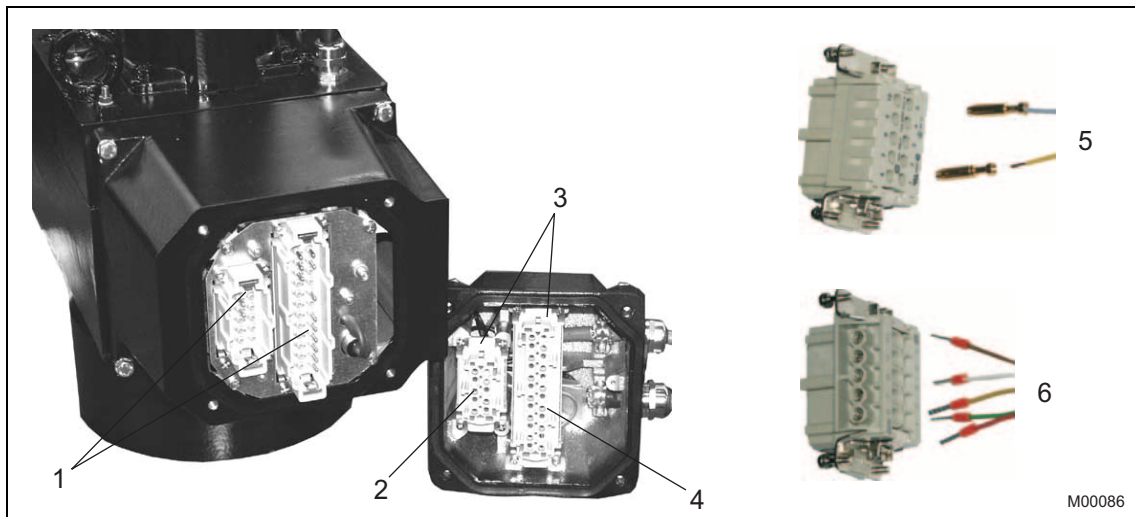

Fig. 15: Plug for electrical connection to the actuator and the integrated electronics

- | | |
|-------------------------------------------------------|-----------------------------------------------|
| 1 Terminal strip (pins) in the plug | 5 Terminal strip for crimped cable connection |
| 2 10-pin socket terminal strip for heating (optional) | 6 Terminal strip for screwed cable connection |
| 3 Terminal blocks (socket) in the connector housing | |
| 4 24-pin socket terminal strip (power and signals) | |

Power electronic unit

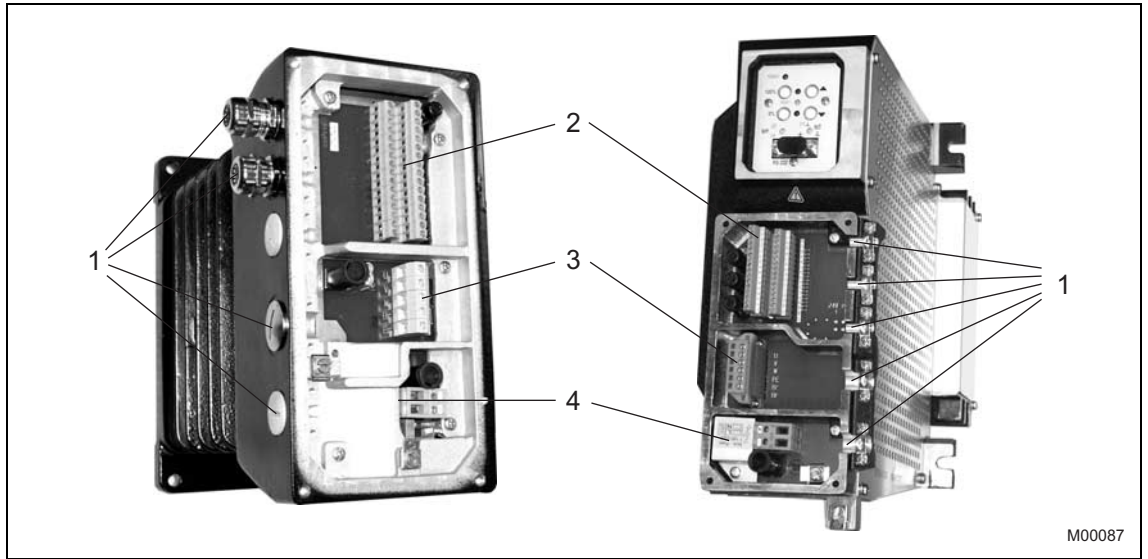
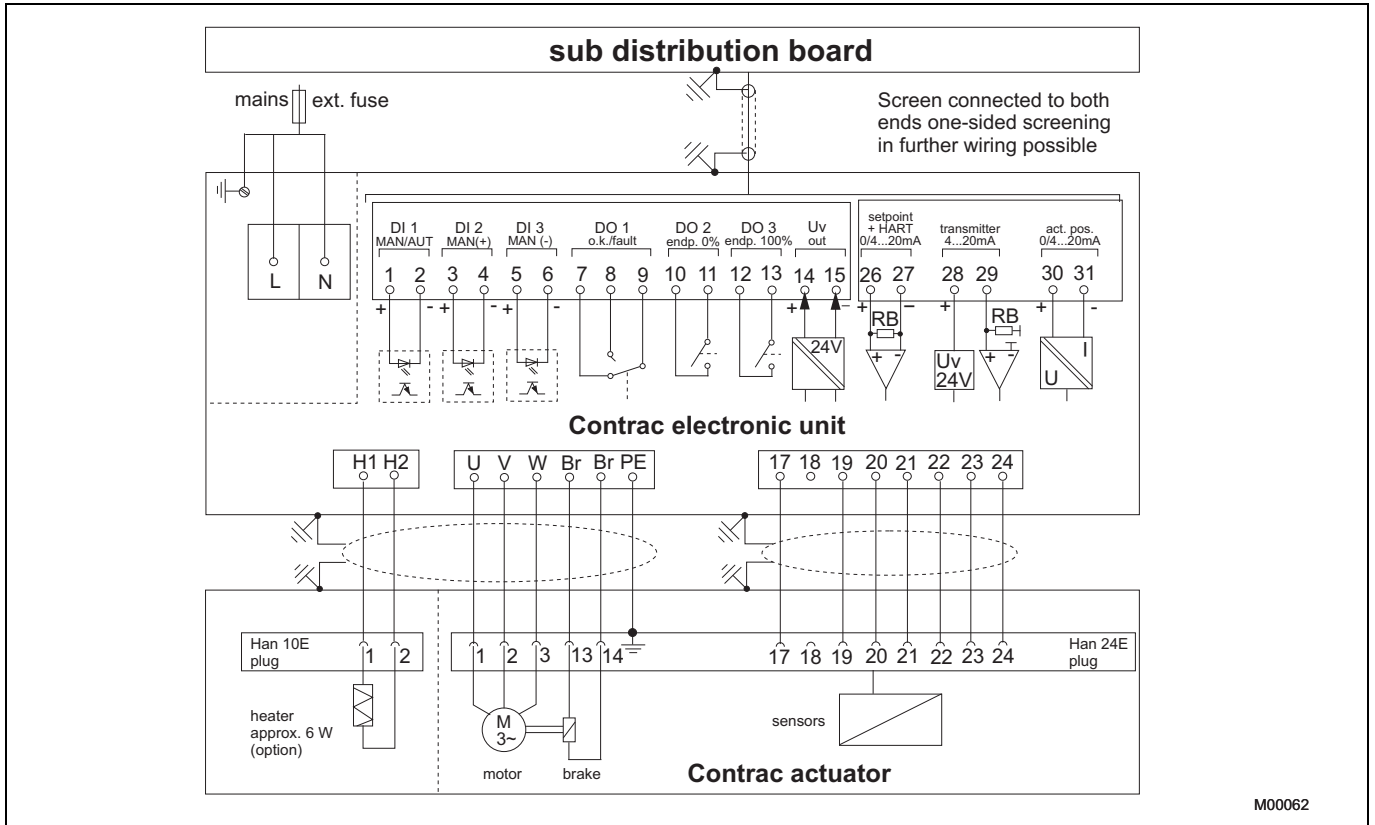

Fig. 16: Example connection details when connecting to a Contrac power electronic unit

- | | |
|---------------------------------|--------------------|
| 1 Cable entries | 3 Motor terminals |
| 2 Terminals for on / off signal | 4 Mains connection |

Screw terminals are used to connect cables for all separately installed power electronic units. The arrangement of the terminals will depend on the version of the power electronic unit (EAN823, EBN853, EBN861, EAS822, EBS852, or EBS862). For details, see Fig. 16.

Wiring diagram



M00062

Fig. 17: Wiring diagram (example based on field mounting of EBN853 / EBN861)

4 Communication

As before, the new generation of Contrac actuators can also be controlled by conventional signals. Users who decide to install intelligent actuators will not be forced to give up their current system concept. They can also be confident that this new generation of actuators will not leave them high and dry. Contrac actuators are designed to be compatible with any new system concepts, e. g. fieldbus, which emerge in the future.

Intelligent actuators are able to communicate through an RS 232 interface, an FSK connection via the HART protocol, or a fieldbus connection. FSK and fieldbus communication are available as options, with both requiring the appropriate form of electronics equipment. A hand-held parameterization facility is also available.

A PC / laptop and the graphical user interface with the Contrac Device Type Manager (DTM) can be used to configure all the actuator functions, as well as to access diagnostics, maintenance, and service information.

However, direct access to the basic functions is also supported locally without the need for any special tools or software. Push buttons and LEDs on the commissioning and service field of the power electronic unit enable the basic setup to be performed both quickly and easily (please also see the Basic setup section, page 21).

4.1 FSK

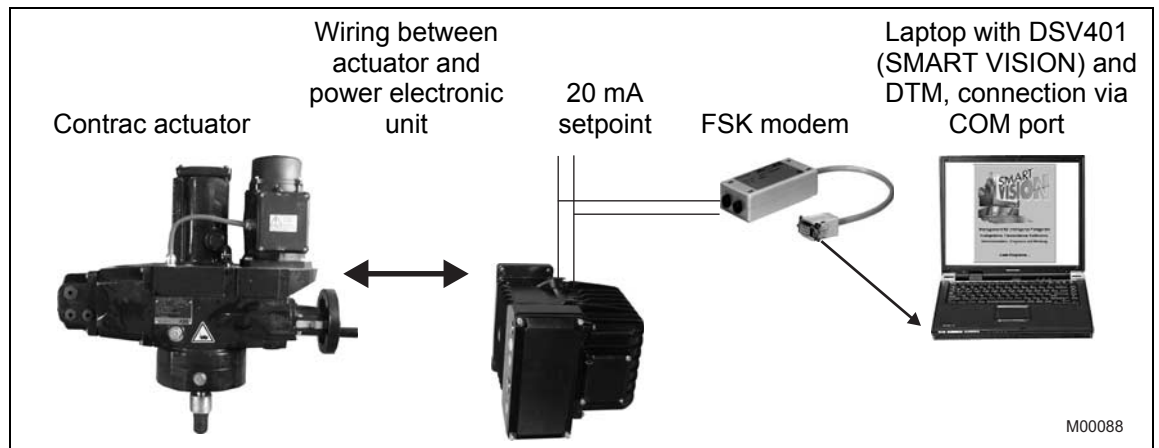

Fig. 18: Arrangement of Contrac components for local communication via FSK modem

4.2 RS 232

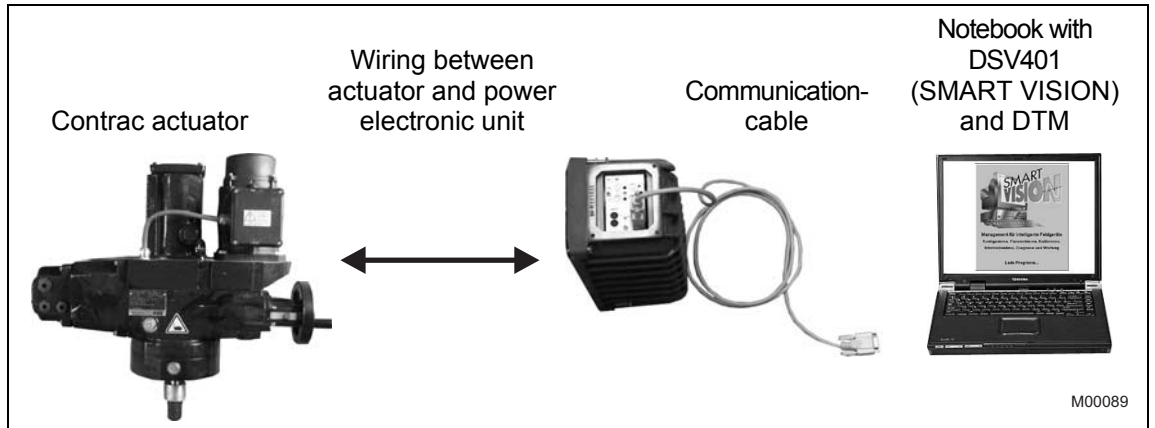

Fig. 19: Arrangement of Contrac components for local communication via communication cable and RS 232 interface

Contrac allows straightforward HART communication via an FSK modem or a control system which supports HART. A data transmission rate of 1200 baud can be achieved with either method. An additional RS 232 interface with a 9-pin socket makes it possible to achieve up to 9600 baud, if a communication cable is connected directly to the COM port of the local PC / laptop.

4.3 Fieldbus

Use fieldbus communication to enjoy the benefits of decentralized intelligence. Gain more process information while cutting down on wiring, documentation, and commissioning time.

Contrac actuators are available for PROFIBUS DP communication. This supports:

- Cyclic data exchange
- Parameterization / configuration via acyclic communication
- Diagnostics
- Configuration using GSD files

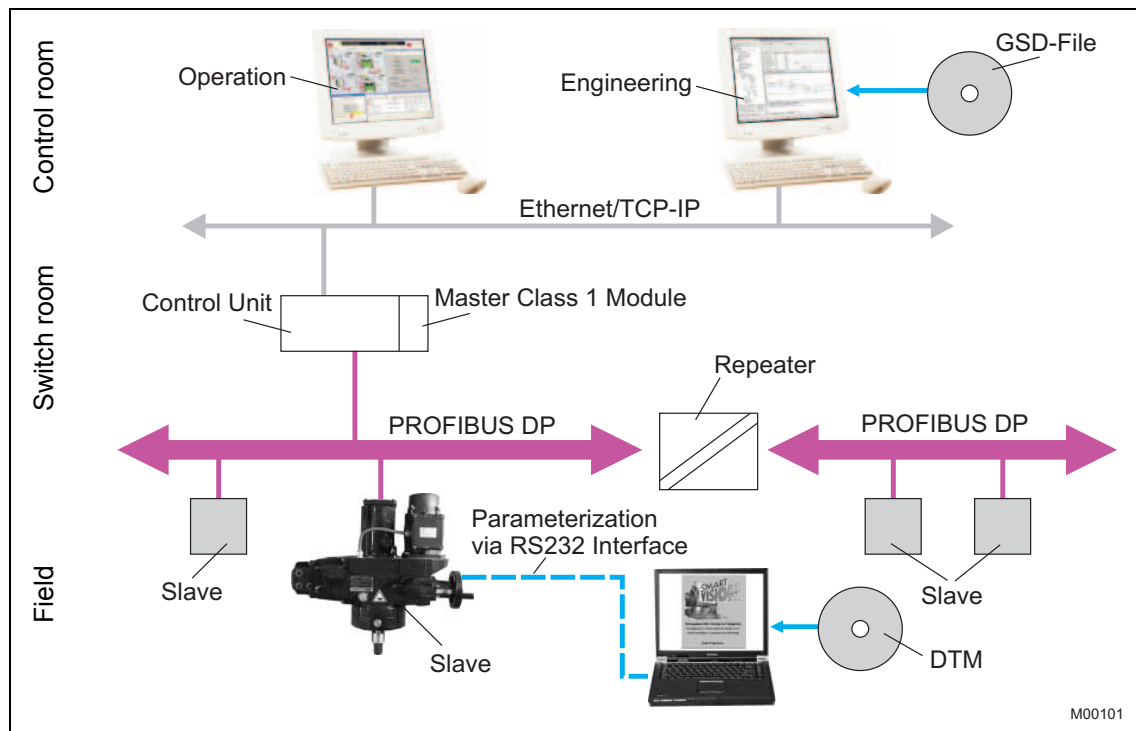

Fig. 20: Arrangement of Contrac components for communication via PROFIBUS DP

5 Software

5.1 Device software

The Contrac system is based on a total of 3 software applications:

- Device software; this is loaded to the Contrac electronic unit and contains the firmware, motor characteristics, and software objects (absolutely essential for operating a Contrac actuator).
- Engineering software (optional)
- Configuration software (optional)

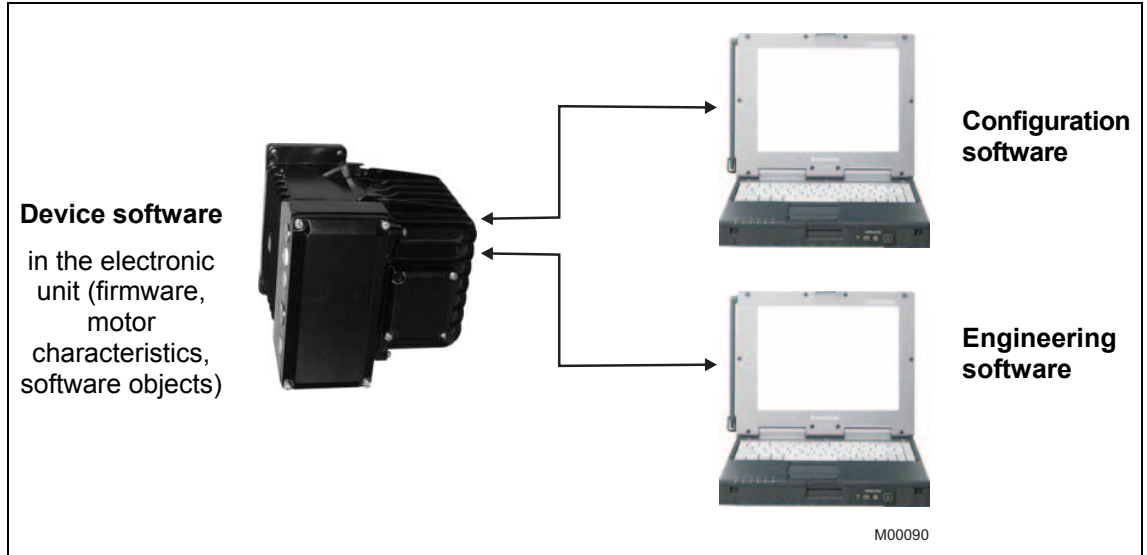

Fig. 21: Contrac software

Firmware

The firmware is the actuator's operating system. It enables it to function, evaluates any limit values, and coordinates functions and the data traffic from / to the engineering and configuration software.

Motor characteristics

The individual power limit and motor behavior are perfectly matched to the given motor / actuator combination. The motor characteristics contain the relevant data.

Software objects

All the parameters relevant to the actuator, e. g., force / torque limits and start behavior (with / without breakaway torque), are specified in the software objects. As the firmware, motor characteristics, and software objects are stored in the electronic unit's flash memory, it is very easy to perform updates in the event of further development or where special applications require adaptations to be made.

5.2 Engineering software

The user cannot set parameters individually for the firmware, motor characteristics, and a number of software objects. With the "ECOM688" ABB engineering software, the firmware, motor characteristics, and software objects can all be read from the electronic unit in the form of "packets" and then stored. "Data packets" can also be called from a data storage medium and written to the memory of the electronic unit.

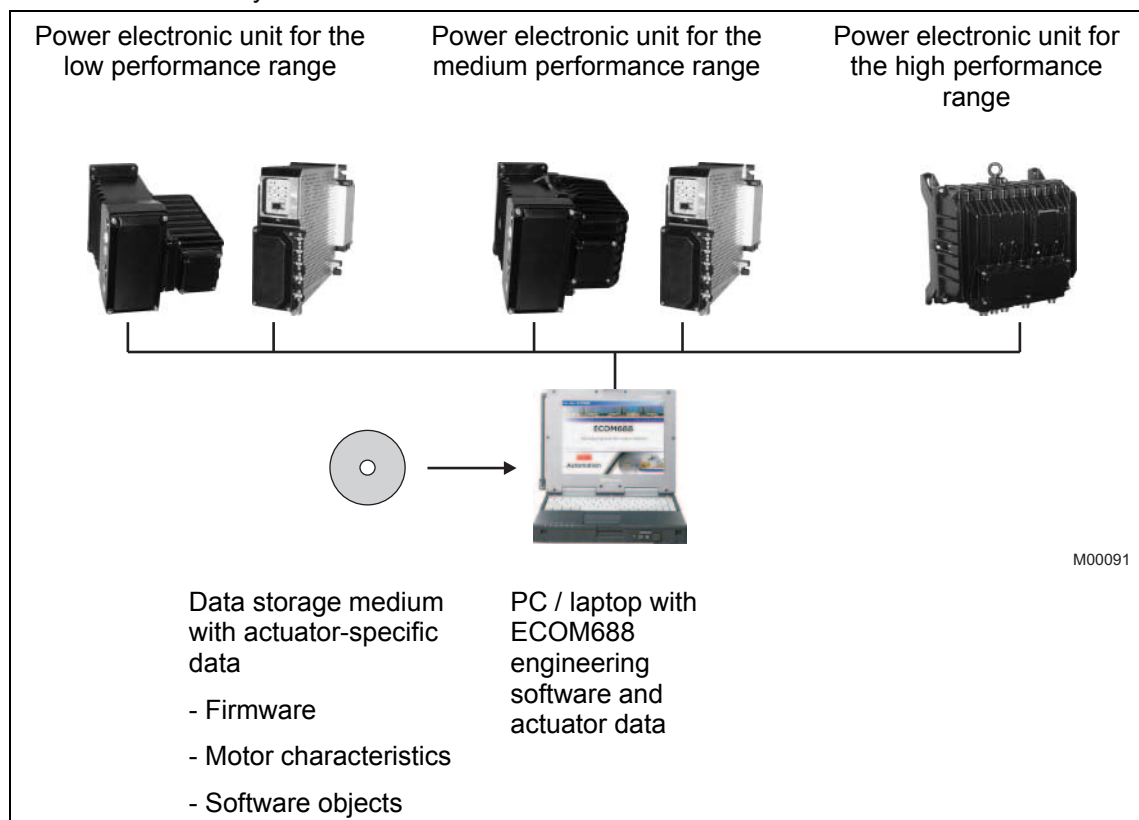

Fig. 22: Data handling with ECOM688

This means the user only has to keep one replacement electronics module in stock for each performance range (see Fig. 22). When an electronic unit needs to be replaced, all the user has to do is load the previously saved data record to the new unit. The positioning loop is ready for immediate operation. There is no need to repeat the basic setup procedure.

Since this scenario does not require the actuator to be moved across the entire operating range again in order to define the end positions, it is often possible to change the power electronic unit while the process is running.

5.3 Configuration software

One piece of configuration software, the Device Type Manager (DTM), enables actuator data to be parameterized within the limits specified by the actuator's operating system (firmware). The user also receives comprehensive diagnostics, service, and maintenance information. A password can be used to protect access to the various function areas. The DTM can be loaded to a frame application which supports FDT / DTM technology. This enables it to be used either locally (e. g., within DSV401 (SMART VISION)) or within a control system.

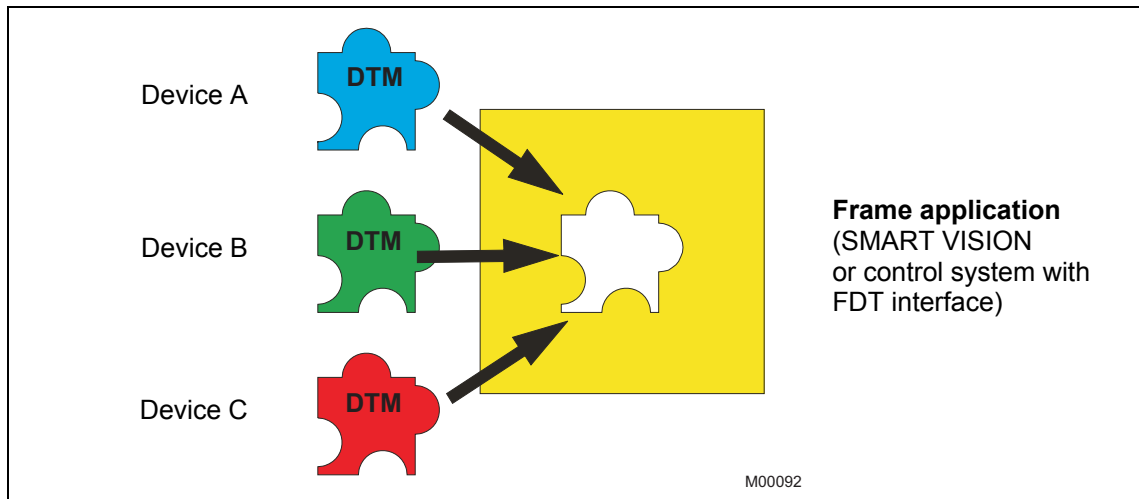

Fig. 23: FDT / DTM principles

The ABB frame application (SMART VISION) and the DTM are available in English and German.

Actuators are supplied with either standard or customized settings. No software is needed for basic setup during commissioning. The software can be used, however, to adapt actuators to any process which may have been modified.

6 Functions

In the past, the vast majority of functions relating to the positioning loop were usually managed within the control system. The growing number of functions, however, has made it increasingly important to reduce the workload for the control system (and the bus communication system). The Contrac design has transferred a large number of parameterization, diagnostics, service, and maintenance functions from the control system to the power electronic unit. The advantages of this are obvious:

Whatever the control system, the user is sure to benefit from Contrac in terms of all the process optimization possibilities that it can offer.

The following sections provide a brief overview. Where appropriate, screenshots of the dialog screens and menus on the graphical user interface have been used to illustrate the descriptions provided.

6.1 Basic setup



Fig. 24: Commissioning and service field

With their unique design, Contrac actuators do not need any torque switches or similar monitoring equipment. Once the mechanical and electrical connections have been made for the device, all the user has to do is perform the basic setup, i. e., set the end positions. This does not require any special tools or software.

Proceed as follows:

- Open the cover for the commissioning and service field on the power electronic unit.
- Select "Adjustment mode".
- Use the relevant keys to move the actuator to both end positions, one after the other.
- Confirm the two end positions as 0 % and 100 % respectively.
- Quit "Adjustment mode".
- Close the cover for the commissioning and service field on the power electronic unit.

For additional details, please refer to the relevant operating instructions.

6.2 Configuration

6.2.1 Operating mode

Positioner following a continuous setpoint

The most commonly used operating mode involves the Contrac actuator continuously following an analog setpoint signal. As the torque / force only rises or falls gently, the mechanical components are not subjected to any peak loads. This results in longer maintenance intervals and extends the service life of the actuator and the control element.

Positioner downstream from a step controller

Contrac can also be operated in this mode, thereby benefiting from reduced wear on equipment, when control commands are received as pulses from a step controller. In "Downstream from step controller" operating mode, incoming control commands received as pulses at digital inputs DI 2 and DI 3 are integrated into an internal memory. The memory uses these pulses to generate an "artificial" internal setpoint which the actuator then follows. This even allows the user to benefit from Contrac's unique operating features in the case of older systems which often still use step control or simple "OPEN-CLOSED" commands.

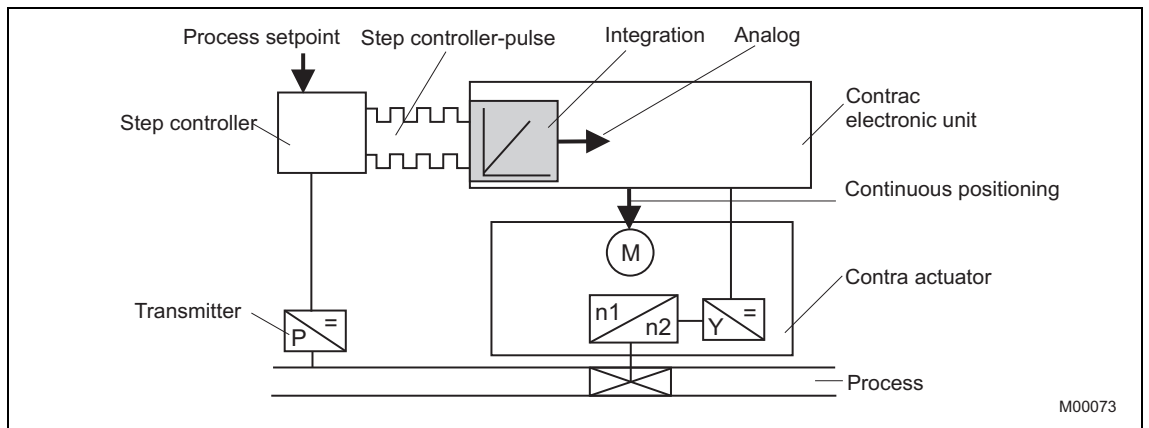

Fig. 25: Integration of step commands into "Downstream from step controller" operating mode

6.2.2 Torque / force

Torques and forces can be set independently of each other and the travel direction. Select "Constant" to set a constant value for 0 % to 100 % (or the other way round) or "Characteristics" to set an individual torque/force characteristic between the end positions.

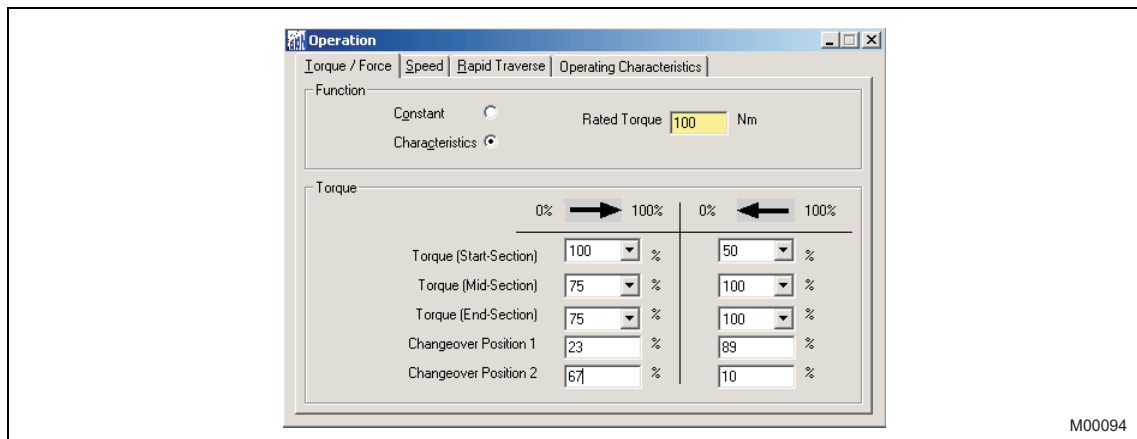

Fig. 26: Screenshot of the menu for setting torque

6.2.3 Speed

The options for setting the speed are similar to those for setting the torque / force.

6.2.4 Driving into end position

The menu enable the user to make individual settings for the respective end positions. The menu offers the following options:

Keep tight with (torque / force):

When the setpoint requests the end position, the actuator remains switched on and forces the control element to the end position "electrically".

Travel-dependent switching off:

As soon as the actuator has reached a defined position, the motor will be switched off, and the brake will be applied and mechanically stop the motor (as well as the actuator and control element) in its current position.

Switching off with 1x or 2x rated torque / rated force:

As soon as the actuator has reached the end position, the motor will increase its torque to the value selected (1x or 2x the rated value) before being switched off and the applied brake will keep the actuator in the end position.

6.2.5 Leaving the end position

Breakaway function:

Where control elements remain in an end position for a long period of time, there is a danger of them getting stuck due to deposits. Often, the levels of torque or force needed to release them are higher than the actuator's rated value allows. Typically, these increased requirements only apply to the end position. As soon as the actuator has left the end position, the rated torque / force value will be sufficient to move the control element. In the end position areas, Contrac is able to make up to 200 % of its rated torque / force available at reduced speeds. Thanks to this ability, Contrac allows control elements to be safely moved from their end positions, even if they have got stuck.

6.2.6 Avoiding movements near the end position

Control movements near the end position:

As far as most control loops are concerned, there is little point, from a technical perspective, in making minimal valve movements near the end position (e. g., at 97 % or 2 %). If, however, process variables change at this control element position, the actuator will follow the resulting control commands, and there is a danger that the valve fitting will sustain permanent damage if it is approached too often. There is also a danger that valve positions very close to the end positions will cause cavitation. To avoid this "hammer effect" and prevent cavitation, the user can define a small area in front of the end positions via the user interface. As soon as the actuator reaches these areas, it behaves in accordance with the settings made in the "Driving into End Position" menu.

6.2.7 Inputs / outputs

Signal range:

When choosing the start and end value for the setpoint, you can select any value between 0 and 20 mA (minimum span of 8 mA). You can select either 0 ... 20 mA or 4 ... 20 mA for the position feedback signal. The output level will always be 0 ... 100 %, whichever range you choose.

Example:

Setpoint:	6 ... 14 mA
Selected position signal area:	4 ... 20 mA
Position signal area:	4 ... 20 mA (0 ... 100 %)

Digital inputs:

Contrac has 3 digital inputs (DI). Functions are assigned via a "group assignment" process based on 4 available groups. When one of the groups is selected from the pulldown menu on the user interface, a function is automatically assigned to each individual input.

- **Off:** The inputs have no function.
- **Manual mode:** In automatic mode, the actuator follows the setpoint continuously. DI 1 is used to switch between MAN / AUT; DI 2 + DI 3 receive the + / - commands.
- **Rapid traverse mode:** In automatic mode, the actuator follows the setpoint continuously. DI 1 is used to switch between MAN / AUT; high signals on DI 2 + DI 3 cause the actuator to run at twice the rated speed at reduced force / torque.

Step controller

DI 1 is used to switch between MAN / AUT; "step commands" (pulses, e. g., from a step controller) on DI 2 and DI 3 are integrated internally. Contrac uses the results to generate an "artificial" internal setpoint. Contrac follows this setpoint continuously in AUT mode. This enables the user to benefit from all the advantages Contrac has to offer, even where older systems with step control are being used. For details, see Fig. 25.

Digital outputs:

Contrac has 3 digital outputs. Each of the functions listed below can be assigned to a selected output via the pulldown menu on the user interface.

- Ready to operate
- End position 0 %
- End position 100 %
- Overshooting a defined position limit value on a rising edge
- Overshooting a defined position limit value on a falling edge
- General alarm message
- Collective failure

Error message via actual value:

In the event of an error, the position signal assumes a value beyond the defined range. The control system responds in accordance with its setting.

This double use of the position signal cuts down on wiring and reduces the number of inputs required in the control system.

6.2.8 Monitoring

Setpoint time-out:

Contrac generates an error message as soon as the setpoint signal assumes a value beyond the defined range. The actuator responds in accordance with its setting (by locking in the last position or driving to a default safety position which can be adjusted as required).

Positioning time-out:

Contrac monitors various positioning loop parameters to ensure there is a consistent response. The actuator electronic unit generates an error message if the actuator overshoots the relevant limit value and the actuator stops. This enables information to be made available in good time, before the process is able to respond.

Functions

6.3 Service

6.3.1 Test

Conrac allows the user to test a number of its components. These include the brake, gearing, or associated modules such as the rod. Repeating a runtime test enables the user to draw conclusions about wear or increased frictional resistance within the linking rod.

One of the key test functions enables the user to document the amount of torque / force available. When this function is initiated, Conrac divides the selected operating range into 21 sections. By traveling across the range at a defined test speed, Conrac is able to calculate the relevant force / torque values via an internal process and displays the results in the menu window of the parameterization software. The values can be printed out or used for further processing.

This function enables Conrac to test forces / torques within its operating range, even when a control element is connected.

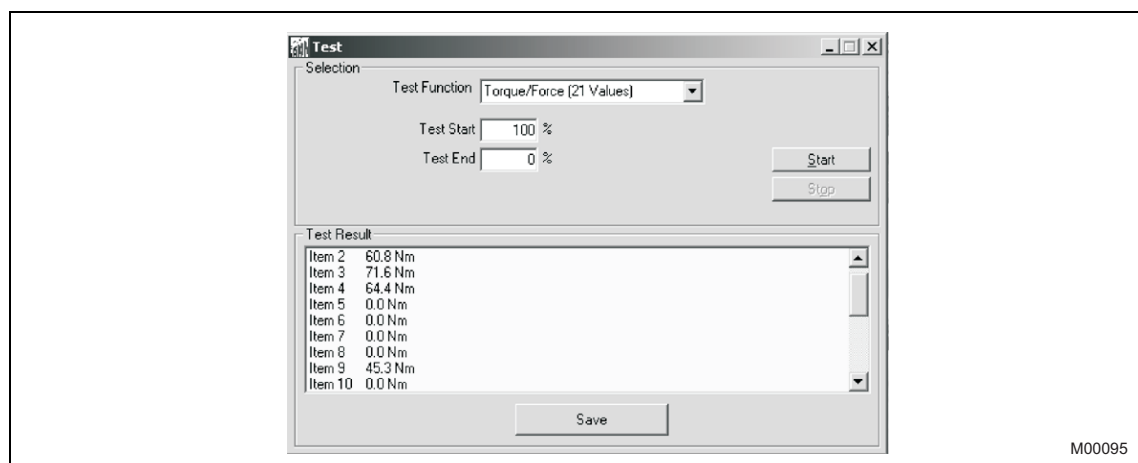

Fig. 27: Menu: "Test"

6.3.2 Signal simulation

Conrac is able to test the signal connections to the control system, without moving the actuator, by simulating "High" / "Low" signals on the digital inputs / outputs and a signal level on the analog input. This function makes for easier commissioning.

6.4 Diagnostics

6.4.1 Status

A non-editable window in the graphical user interface provides status information on the:

- Operating mode (MAN / AUT)
- Function (positioner / controller)
- Test mode (yes / no)
- Simulation mode (yes / no)
- Local operation (yes / on)
- Existence of a general alarm (yes / no)
- Existence of a collective failure (yes / n o)

6.4.2 Alarms/Errors

Contrac provides detailed information on current or previous alarm and error messages. An alarm message is generated when the actuator is in a critical situation which does not, however, currently present a danger to the safety of a process (e. g. high temperature).

An error message is generated when the actuator is in a critical situation which presents a danger to the ongoing safety of a process (e. g., a CPU error). The user interface displays both current alarm and error messages as well as the respective history of previous messages.

The values can be printed out or used for further processing.

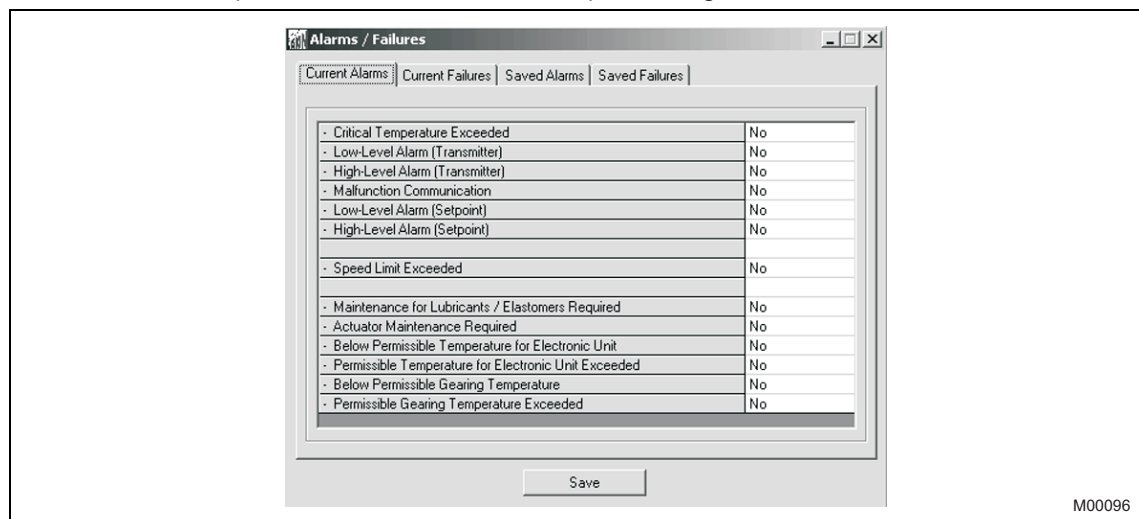

Fig. 28: Screenshot of the detailed "Alarms / Failures" menu

Functions

6.4.3 Maintenance

An actuator's service life depends on a number of factors. Contrac evaluates these factors (e. g., temperatures, number of motor reversals, peak loads) and uses them to calculate when the next round of maintenance work will be required. This "load-driven" maintenance philosophy supports a more scientific approach to system management.

6.4.4 Load

The reasons behind certain error patterns can be only be determined with the help of detailed information. Contrac saves the parameters relating to service life (e. g. number of motor reversals, maximum temperature values for the gearing and electronics, peak loads, and the dynamic loads to which the actuator has been exposed). Use the graphical user interface to display these values or save them for evaluation at a later time.

6.4.5 Recording

Every technician knows how hard it is to establish the cause of non-reproducible errors. They come and go without leaving any clues as to when and why. To help reduce error investigation work, Contrac is able to record parameters relevant to the positioning loop (e. g. setpoint, actual position value, temperature, motor frequency, etc.) during operation by means of the graphical user interface. As the sample rate for the measuring process can be adjusted, recordings can also be made over longer periods.

6.4.6 Integrated PID controller

The integrated PID controller, which is available as an option, can be used to set up an island control loop without a control system or additional controller. The controller is parameterized via the graphical user interface.

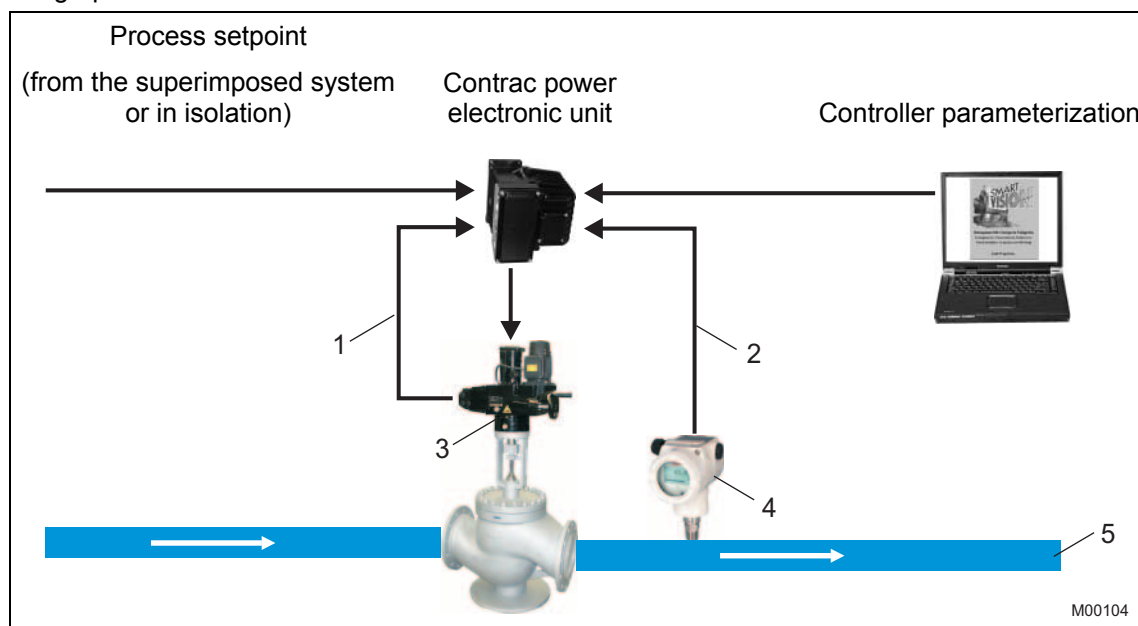

Fig. 29: Modules within the control / positioning loop

- | | |
|------------------------|---------------|
| 1 Position feedback | 4 Transmitter |
| 2 Process actual value | 5 Process |
| 3 Contrac actuator | |

7 Actuator with explosion proof design

Automation tasks performed in explosion risk areas such as refineries and gas pipelines require actuators with an explosion proof design.

The Contrac system matches these requirements with its explosion proof actuators according to ATEX (II 2 GD ck EEx de [ib] ib II B T4 or IP 6x T = 130 °C ZELM 04 ATEX 0209 X) or Rostechnadzor (2 Ex deib [ib] II B T 4 DIP A21 TA 130 °C, IP 66) for installation in hazardous areas and its power electronic units for installation in non-hazardous areas (see Fig. 32 and Fig. 33).

The actuators feature a servo motor in flameproof housing and an EEx connection area.



M00097

Fig. 30: Pipeline



M00098

Fig. 31: Contrac RSDE20 at a gas station

An additional motor temperature monitoring unit interrupts the power supply as soon as the motor temperature exceeds the permissible limit.

Explosion-proof Contrac actuators offer the full range of functions and user benefits associated with standard models.

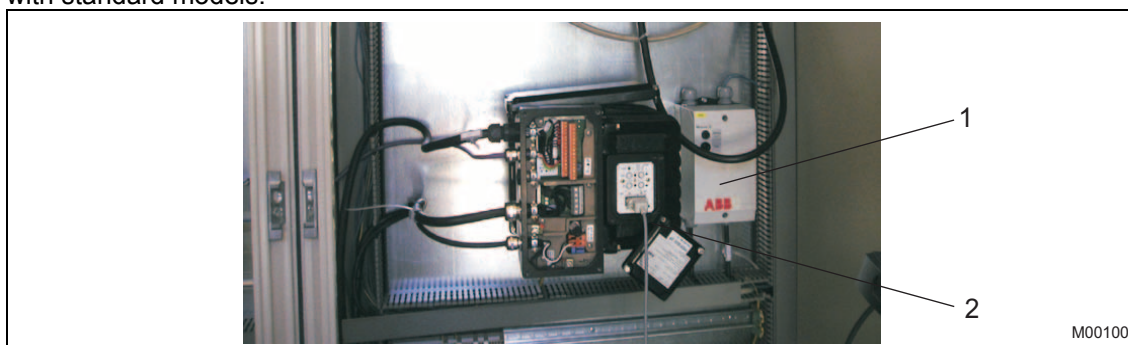

M00100

Fig. 32: Contrac power electronic unit and motor temperature monitoring unit in a non-explosive area

- 1 SD241-B
- 2 Contrac power electronic unit

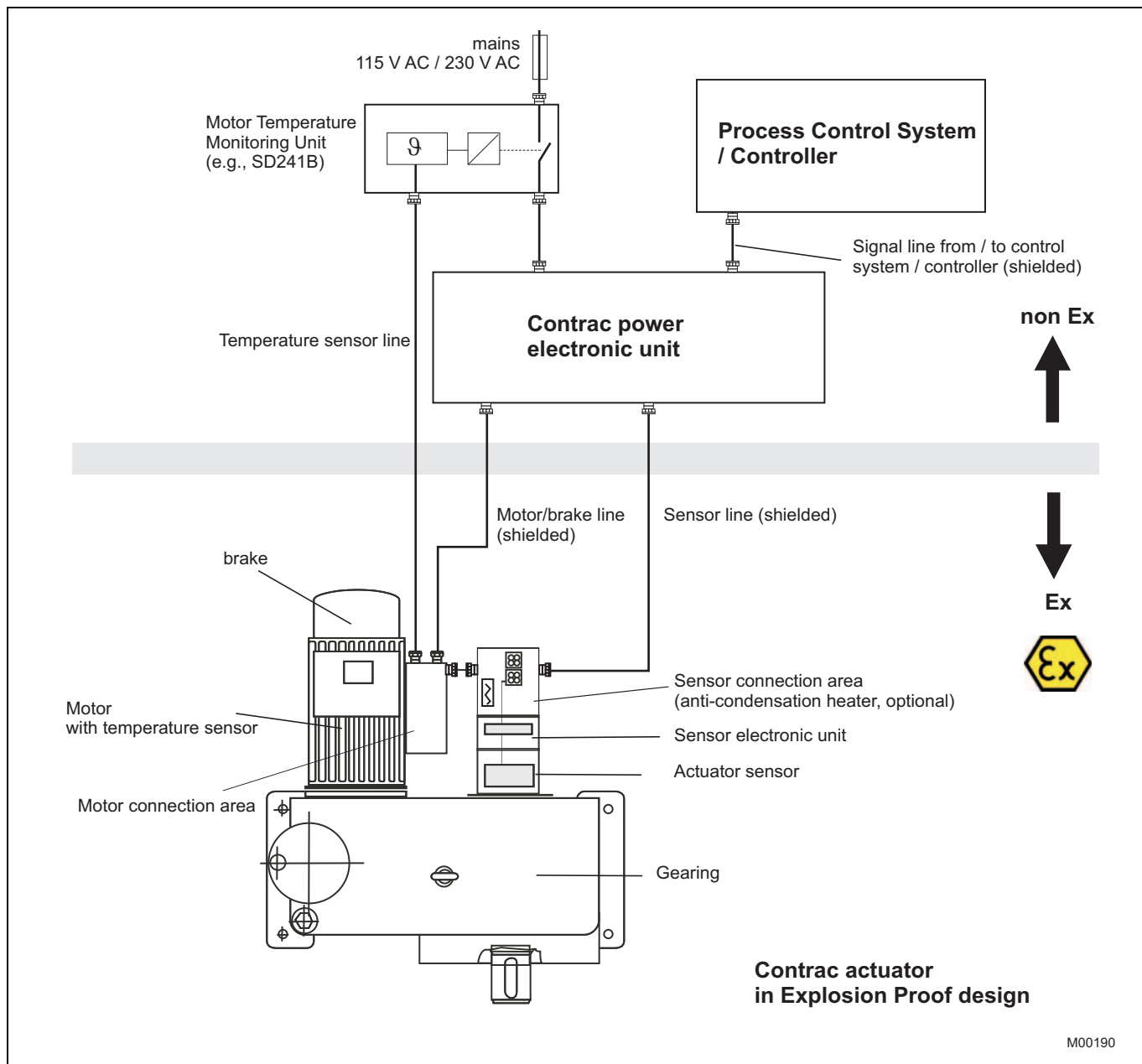

Fig. 33: Arrangement of Contrac modules in an "explosion proof application"

8 Installation examples

Power plant



Fig. 34: Controlling exhaust gas using a rotary actuator on a multi-leaf valve



Fig. 37: Rotary actuator (air control)



Fig. 35: Linear actuator (feed-water preheating)

Cement industry



Fig. 38: Milling air control; rotary actuator RHD250 (rated torque 250 NM)



Fig. 36: Horizontally installed linear actuator (air control)

Gas distribution



Fig. 39: Commissioning support from specialist ABB personnel during installation of an explosion-proof linear actuator RSDE10

ABB has Sales & Customer Support expertise in over 100 countries worldwide.

www.abb.com/instrumentation

The Company's policy is one of continuous product improvement and the right is reserved to modify the information contained herein without notice.

Printed in the Fed. Rep. of Germany (02.2009)

© ABB 2009

KXE100003R2901



ABB Limited

Salterbeck Trading Estate
Workington, Cumbria
CA14 5DS
UK
Tel: +44 (0)1946 830 611
Fax: +44 (0)1946 832 661

ABB Inc.

125 E. County Line Road
Warminster, PA 18974
USA
Tel: +1 215 674 6000
Fax: +1 215 674 7183

ABB Automation Products GmbH

Schillerstr. 72
32425 Minden
Germany
Tel: +49 551 905-534
Fax: +49 551 905-555
CCC-support.deapr@de.abb.com