

Power electronic unit for cabinet installation EBS852, EBS862 (Contract)

To control Contrac actuators
in areas with explosion protection

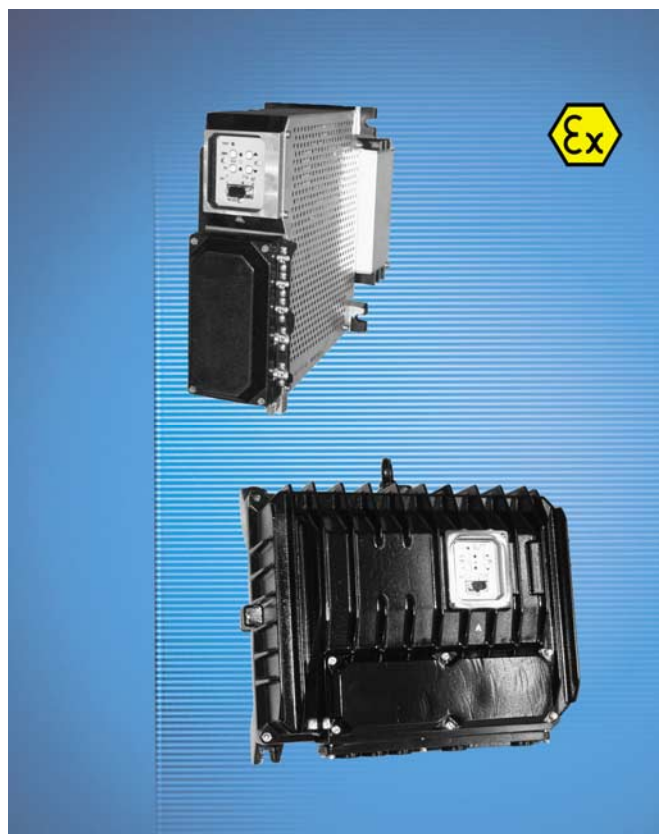
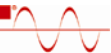

HART 
COMMUNICATION PROTOCOL

PROFI
PROCESS FIELD BUS
BUS

Power electronic unit for cabinet installation EBS852, EBS862 (Contrac)

Operating Instruction

42/68-831-EN

07.2008

Rev. A

Manufacturer:

ABB Automation Products GmbH

Schillerstraße 72

32425 Minden

Germany

Tel.: +49 551 905-534

Fax: +49 551 905-555

CCC-support.deapr@de.abb.com

© Copyright 2008 by ABB Automation Products GmbH
Subject to change without notice

This document is protected by copyright. It assists the user with the safe and efficient operation of the device. The contents may not be copied or reproduced in whole or in excerpts without prior approval of the copyright holder.

1	Safety	5
1.1	General Safety Information	5
1.2	Proper use.....	5
1.3	Technical limits.....	6
1.4	Warranty provision	6
1.5	Labels and symbols.....	6
1.5.1	Symbols and warnings	6
1.5.2	Name plate for EBS852 electronic unit.....	7
1.5.3	Name plate for EBS862 electronic unit.....	8
1.6	Operator liability	9
1.7	Personnel qualification	9
1.8	Returning devices.....	9
1.9	Disposal.....	10
1.9.1	Information on WEEE directive 2002/96/EC (Waste Electrical and Electronic Equipment)	10
1.10	Transport safety information	10
1.11	Storage conditions.....	10
1.12	Installation safety information.....	11
1.13	Electrical installation safety information	11
1.14	Operating safety information	11
2	Explosion-protection safety precautions	12
2.1	Operation via frequency transformer.....	12
2.2	Using the engineering software Save & Restore and ECOM688	12
3	Design and function	13
3.1	Modules.....	14
3.1.1	EBS852	14
3.1.2	EBS862	15
4	Installation	16
4.1	EBS852	16
4.2	EBS862	17
5	Electrical connection	18
5.1	Actuator assignment and cable cross-sections.....	19
5.1.1	Rotary actuators.....	19
5.1.2	Linear actuators	19
5.2	Cable shield.....	20
5.2.1	Signal part	20
5.3	Terminal connection diagrams	21
5.3.1	Power Electronic Unit EBS852 (Contrac) / EBS862 (Contrac).....	21
5.4	Fuses.....	22
5.4.1	EBS852	22

Contents

5.4.2	EBS862	22
5.4.3	External fuse for EBS862	22
5.5	Connection elements	23
5.5.1	EBS852	23
5.6	EBS862	24
5.7	Cable guide	25
5.8	Mains distribution	26
5.9	Cable routing in the connector	26
6	Local operation	27
6.1	General information on operation	27
6.2	Operating elements of the service field (ISF)	28
7	Commissioning and service field (ISF)	29
7.1	Typical commissioning with the service field (ISF)	29
7.1.1	Status	29
7.1.2	"Device setup" operating mode	29
7.1.3	Setup via user interface	29
7.1.4	Defining the initial position (0% or 100%)	30
7.1.5	Defining the second position (0% or 100%)	30
7.1.6	Saving your settings	30
7.1.7	Correcting your settings	31
8	Alarms / Errors	32
8.1	Definition	32
8.1.1	Alarms	32
8.1.2	Error	32
8.2	Alarm diagram	33
8.3	Error diagram	34
9	Trouble shooting	35
10	Technical data	36
10.1	General information	36
10.2	Technical data for the EBS852	36
10.3	Technical data for the EBS862	37
11	Appendix	38
11.1	Permits and certifications	38
12	Index	40

1 Safety

Read these operating instructions carefully prior to installing and commissioning the device.

These instructions are intended as an overview and do not contain detailed information on all designs for this product or every possible aspect of installation, operation and maintenance.

For additional information or in case specific problems occur that are not discussed adequately in these instructions, contact the manufacturer. The content of these instructions is neither part of any previous or existing agreement, promise or legal relationship nor is it intended to change the same.

All obligations of ABB Automation Products GmbH are created by the relevant sales agreement, which contains the complete and solely binding warranty regulations. These contractual warranty provisions are neither extended nor limited by compliance with this manual.

1.1 General Safety Information

The "Safety" chapter provides an overview of the safety aspects to be observed for the operation of the device.

The device is built based on state-of-the-art technology and is operationally safe. It was tested and left the factory in a proper state. The requirements in the manual as well as the documentation and certificates must be observed and followed in order to maintain this state for the period of operation.

The general safety requirements must be complied with completely during operation of the device. In addition to the general information, the individual chapters of the manual contain descriptions about processes or procedural instructions with specific safety information.

Only the observance of all safety information enables the optimal protection of personnel as well as the environment from hazards and the safe and trouble-free operation of the device.

1.2 Proper use

The EBS852 and EBS862 type power electronic units interconnected as illustrated in these operating instructions are used exclusively to control RHDE... or RSDE... series electrical actuators. Using these actuators for any other purpose will introduce a risk of personal injury and can also damage or impair the device's operational reliability.

Repairs, alterations and enhancements or the installation of replacement parts is only permissible as far as described in the manual. Further actions must be verified with ABB Automation Products GmbH. Excluded from this are repairs performed by ABB-authorized specialist shops.

1.3 Technical limits

The device is designed for use exclusively within the stated values on the name plate and in the technical specifications (see "Technical Specifications" chapter and data sheet). These must be complied with accordingly, e.g.:

- The maximum operating temperature may not be exceeded.
- The permitted operating temperature may not be exceeded.
- The housing protection system must be observed.

1.4 Warranty provision

A use contrary to the device's stipulated use, disregarding of this manual, the use of under-qualified personnel as well as unauthorized alterations excludes the manufacturer of liability from any resulting damages. The manufacturer's warranty expires.

1.5 Labels and symbols

1.5.1 Symbols and warnings



Danger – <Serious damage to health / risk to life>

One of these symbols in conjunction with the "Danger" warning indicates an imminent danger. If it is not avoided, death or serious injury will result.



Warning – <Bodily injury>

The symbol in conjunction with the "Warning" message indicates a possibly dangerous situation. If it is not avoided, death or serious injury could result.



Caution – <Slight injuries>

The symbol in conjunction with the "Caution" message indicates a possibly dangerous situation. If it is not avoided, slight or minor injury can result. May also be used for property damage warnings.



Notice – <Property damage>

The symbol indicates a possibly damaging situation. If it is not avoided, the product or something in its area can be damaged.



Important

The symbol indicates operator tips or especially useful information. This is not a message for a dangerous or damaging situation.

1.5.2 Name plate for EBS852 electronic unit

1.5.2.1 Name plate for hardware description

1	Elektronik / Electronics Type: ...		Made in Germany
2	B-Nr./No.	NL	
3	U = 230 V ...	Jahr/Year	
4	f = 50/60 Hz ± 5 %	P= max. W	
5	t = °C	IP 20	
6	Ext. Sicherung / Fuse	CE	
		ABB	
		Automation D-32425 Minden	

M00441

Fig. 1

- | | |
|---|--|
| <ul style="list-style-type: none"> 1 Electronic unit type 2 Unit no. / No. of the non-list version 3 Permissible voltage range / Year of manufacture | <ul style="list-style-type: none"> 4 Permissible line frequency / Max. power consumption 5 Permissible ambient temperature / Protection class 6 Specifications for external fuse protection |
|---|--|

1.5.2.2 Name plate for software description

1	Für / For Antrieb / Actuator
2	Nennwerte / Rated Values M= °/s=
3	F-Nr. / No.
4	NL.
5	Software Version
6	

M00361

Fig. 2

- | | |
|---|---|
| <ul style="list-style-type: none"> 1 Associated actuator 2 Number of the non-list version 3 Installed software version | <ul style="list-style-type: none"> 4 Set force (torque) / Set speed 5 Blank for customer-specific entry |
|---|---|

1.5.3 Name plate for EBS862 electronic unit

The name plates for the power electronic unit are located on the lower section (mains connection) as well as on the cover (electronic unit and software). Since the modules are stand-alone units, order numbers may vary.

1.5.3.1 Name plate on the lower section of the electronic unit

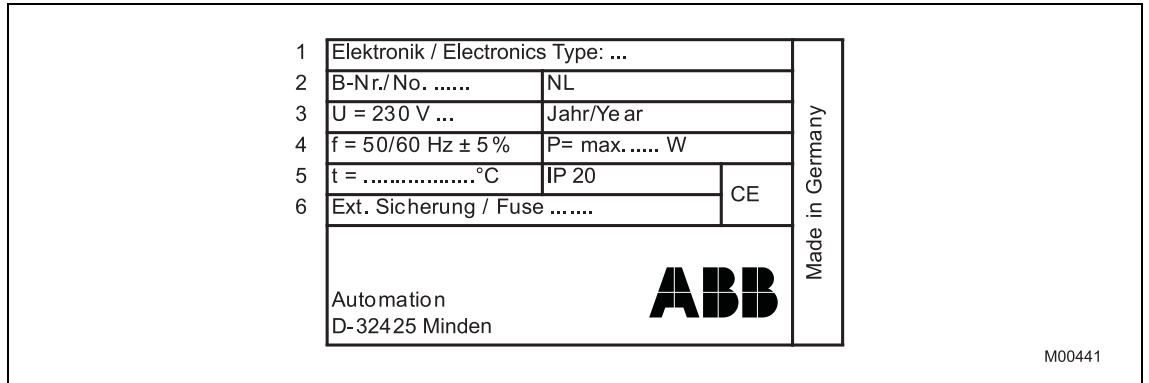

Fig. 3

- | | |
|---|--|
| <ul style="list-style-type: none"> 1 Electronic unit type 2 Unit no. / No. of the non-list version 3 Permissible voltage range / Year of manufacture | <ul style="list-style-type: none"> 4 Permissible line frequency / Max. power consumption 5 Permissible ambient temperature / Protection class 6 Specifications for external fuse protection |
|---|--|

1.5.3.2 Name plate on electronic unit cover

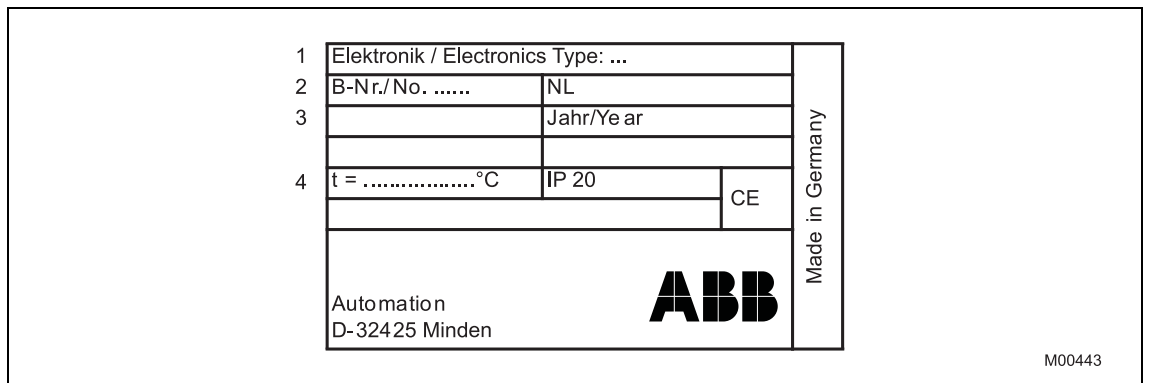

Fig. 4

- 1 Associated actuator
- 2 Unit no. / No. of the non-list version
- 3 Year of manufacture
- 4 Permissible ambient temperature / Protection class

1.5.3.3 Name plate for software description

1	Für / For Antrieb / Actuator
2	Nennwerte / Rated Values M= °/s=
3	F-Nr. / No.
4	NL.
5	Software Version
6	

M00361

Fig. 5

- | | |
|---|---|
| <ul style="list-style-type: none"> 1 Associated actuator 2 Number of the non-list version 3 Installed software version | <ul style="list-style-type: none"> 4 Set force (torque) / Set speed 5 Blank for customer-specific entry |
|---|---|

1.6 Operator liability

The operators must strictly observe the applicable national regulations in their countries with regards to installation, function tests, repairs, and maintenance of electrical devices.

1.7 Personnel qualification

The installation, commissioning and maintenance of the device may only be carried out through trained specialist personell authorized by the plant operator. The specialist personnel must have read and understood the manual and comply with its instructions.

1.8 Returning devices

Use the original packaging or a suitably secure packaging for returning the device for repair or for recalibration. Include the properly filled out return form (see attachment) with the device.

According to EC guidelines for hazardous materials, the owner of hazardous waste is responsible for its disposal or must observe the following regulations for its shipping:

All delivered devices to ABB Automation Products GmbH must be free from any hazardous materials (acids, alkali, solvents, etc.).

1.9 Disposal

ABB Automation Products GmbH actively promotes environmental consciousness and has an operational management system in accordance with DIN EN ISO 9001:2000, EN ISO 14001:2004 and OHSAS 18001. Our products and solutions should have minimum impact on the environment and persons during manufacture, storage, transport, use and disposal.

This includes the environmentally friendly use of natural resources. Through its publications ABB conducts an open dialog with the public.

This product/solution is manufactured from materials that can be reused by specialized recycling companies.

1.9.1 Information on WEEE directive 2002/96/EC (Waste Electrical and Electronic Equipment)

This product/solution is not subject to the WEEE directive 2002/96/EC and relevant national laws (e.g., ElektroG in Germany).

Dispose of the product/solution directly in a specialized recycling facility and do not use the municipal garbage. Only privately used products may be disposed of in the municipal garbage according to the WEEE directive 2002/96/EC. Proper disposal prevents negative effects on people and the environment, and supports the reuse of valuable raw materials.

If it is not possible to dispose of old equipment properly, ABB Service can accept and dispose of returns for a fee.

1.10 Transport safety information

Check the devices for possible damage that may have occurred during transport. Damages in transit must be recorded on the transport documents. All claims for damages must be claimed without delay against the shipper and before the installation.

1.11 Storage conditions

The power electronic units EBS852, EBS862 (Contrac) have an enclosure rating of IP 20. They must be stored as appropriate for this protection class. Condensation is not permitted.

Moisture content must not exceed an annual average of 75 %.

The permissible storage and transport temperatures must be observed.

If you intend to store or transport the device for a prolonged period, we recommend that you wrap it in plastic film and add desiccant. Check that the desiccant is still active on a regular basis.

1.12 Installation safety information

- Only qualified specialists who have been trained for these tasks are authorized to mount and adjust the control actuator, and to make the electrical connection.
- When working on the actuator itself or the electronics always observe the locally valid accident prevention regulations and the regulations concerning the construction of technical installations.
- Switch off the supply voltage and protect against unintentional startup.

1.13 Electrical installation safety information

The electrical connection may only be performed by authorized specialist personnel according to the electrical plans.

Comply with electrical connection information in the manual. Otherwise, the electrical protection class can be affected.

The secure separation of contact-dangerous electrical circuits is only guaranteed when the connected devices fulfill the requirements of the DIN EN 61140 (VDE 0140 Part 1) (basic requirements for secure separation).

For secure separation, run the supply lines separated from contact-dangerous electrical circuits or additionally insulate them.

1.14 Operating safety information

Before switching on, ensure that the specified environmental conditions in the “Technical Specifications” chapter or data sheet are complied with and that the power supply voltage corresponds with the voltage of the electronic unit.

When there is a chance that safe operation is no longer possible, put the device out of operation and secure against unintended operation.

When mounting the power electronic unit in areas that may be accessed by unauthorized persons, take the required protective measures.

2 Explosion-protection safety precautions

2.1 Operation via frequency transformer

- The frequency converter (electronic unit) may not be installed or used within the hazardous area.
- Check whether the electronic unit is loaded with the parameters of the actuator it is connected to.
- Check the electronic unit for proper connection to the correct actuator.
- Setpoint monitoring is activated as default setting when the electronic unit leaves the manufacturer. Do not de-activate this setting.
- Rapid traverse mode is not allowed on Ex actuators, and the feature cannot be activated from the user interface.
- The Contrac power electronic unit must be upstream from the motor temperature monitoring unit SD241-B or similar, certified tripping unit.

2.2 Using the engineering software Save & Restore and ECOM688

Reinstalling the electronic unit software or individual data sections with the engineering software Save & Restore or ECOM688 may only be performed in compliance with the relevant basic conditions. It must be ensured, specifically, that the data record imported belongs to the actuator type. After importing a data record, always check that all parameters for the application such as speed and torque/force are configured accordingly.

Downdating the actuator operating system (UAPM software version) is not permitted.

Refer to the valid operating instructions for the engineering software ECOM688. The operating instructions are available for download on the internet.

3 Design and function

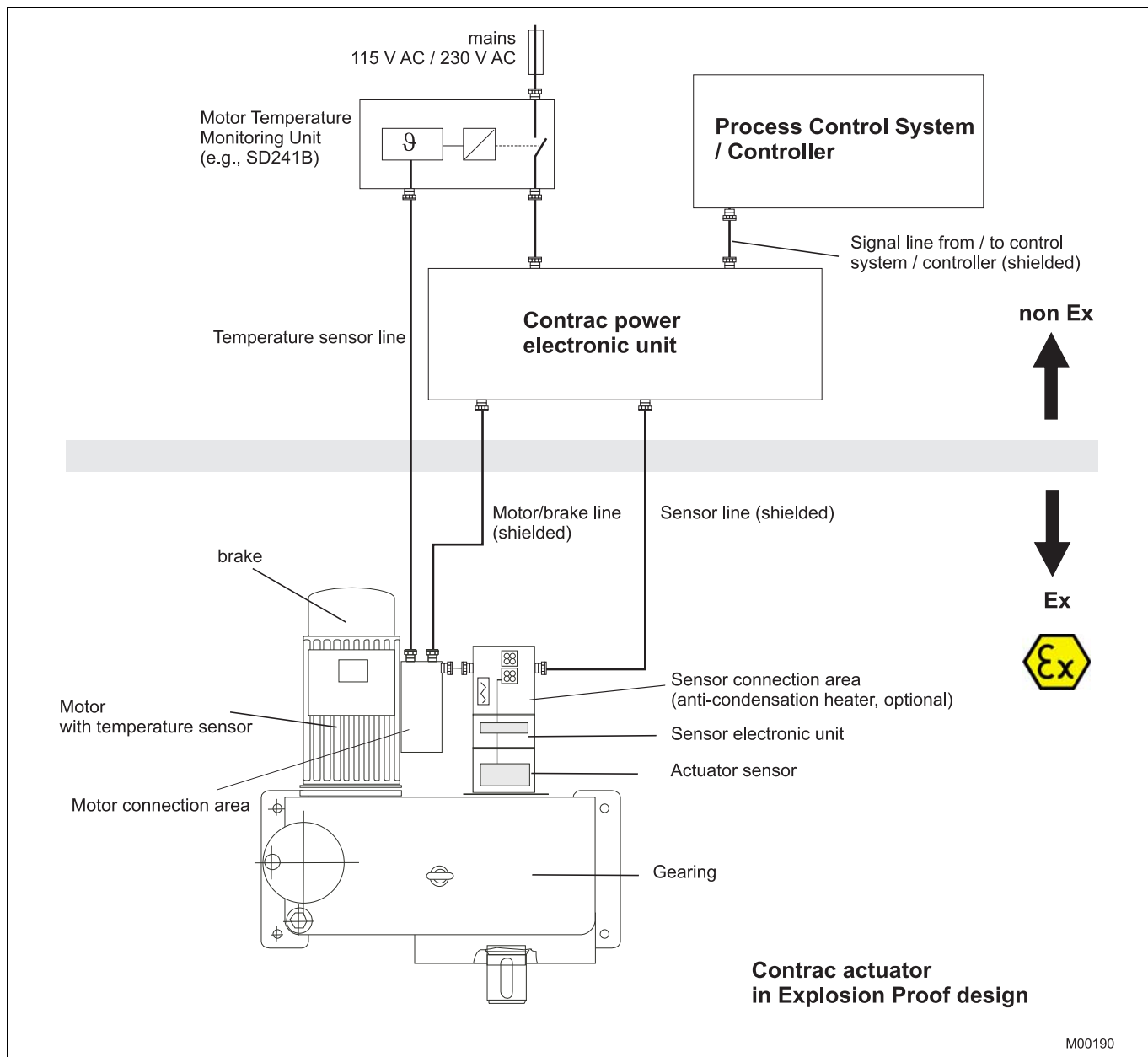

Fig. 6: Ex design

Functionality

The electronic units for the Contrac RHDE... and RSDE... series actuators are available in two sizes for rack mounting. Special parameters can be used to adapt the electronic units to the type of actuator concerned. The electronic units EBS852, EBS862 (Contrac) are the interface between actuator / valves and fittings and process control system.

The actuators / valves and fittings are positioned continuously, whatever the type of input signal (analog or digital). During continuous positioning the motor torque is varied steplessly until the actuator force and the restoring process forces are balanced.

High positioning accuracy combined with excellent control quality and a long actuator life can even be achieved under varying load conditions and with short stroke times.

3.1 Modules

3.1.1 EBS852

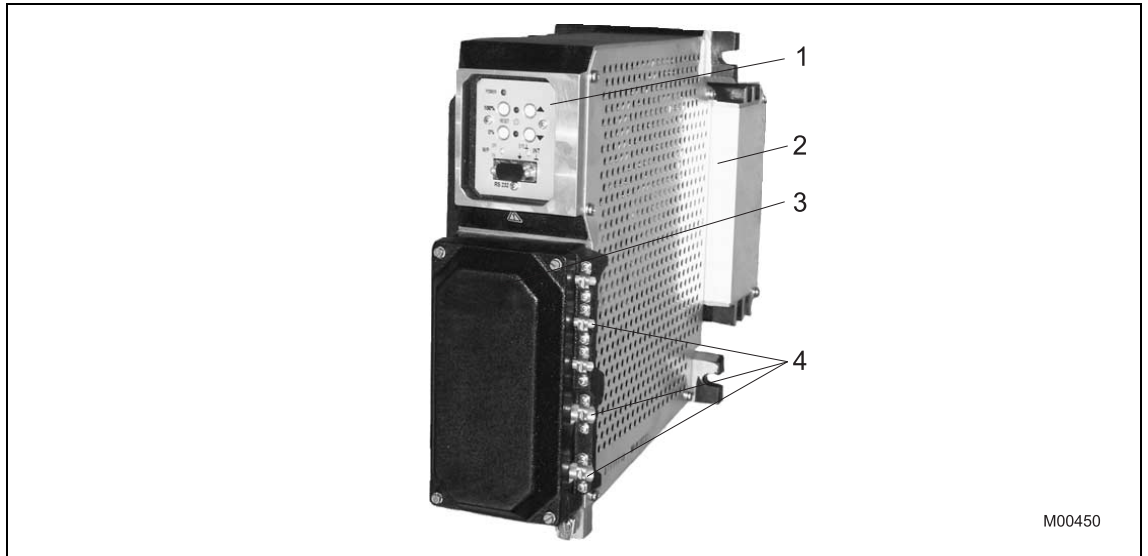

Fig. 7: EBS852

- 1 Commissioning and service field (ISF)
- 2 Transformer
- 3 Cover for connection space
- 4 Cable clamps

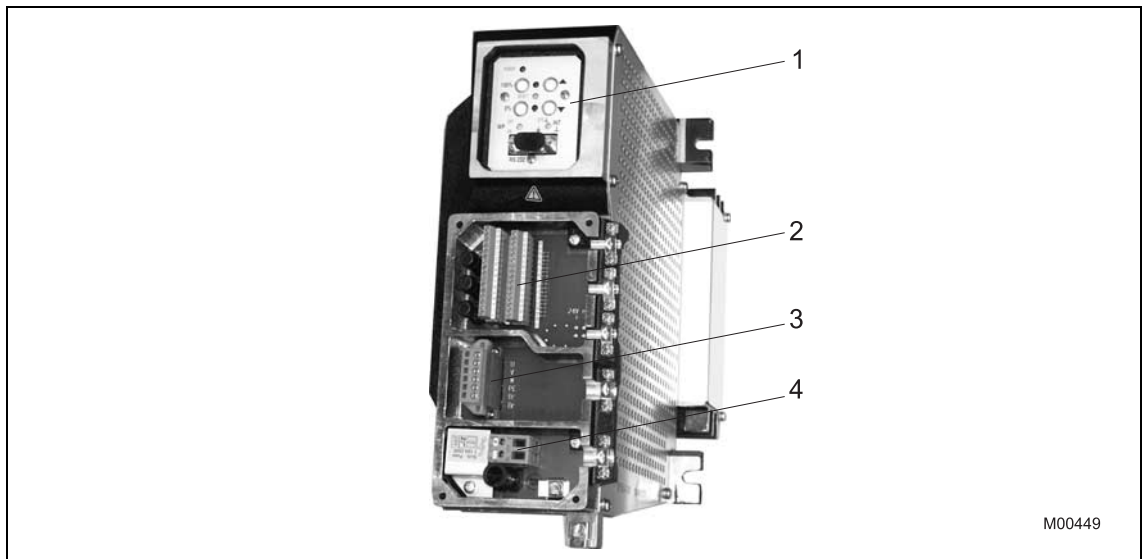

Fig. 8: EBS852 connection space

- 1 Commissioning and service field (ISF)
- 2 Terminals for signal inputs and outputs
- 3 Terminals for motor connection
- 4 Mains connection

3.1.2 EBS862

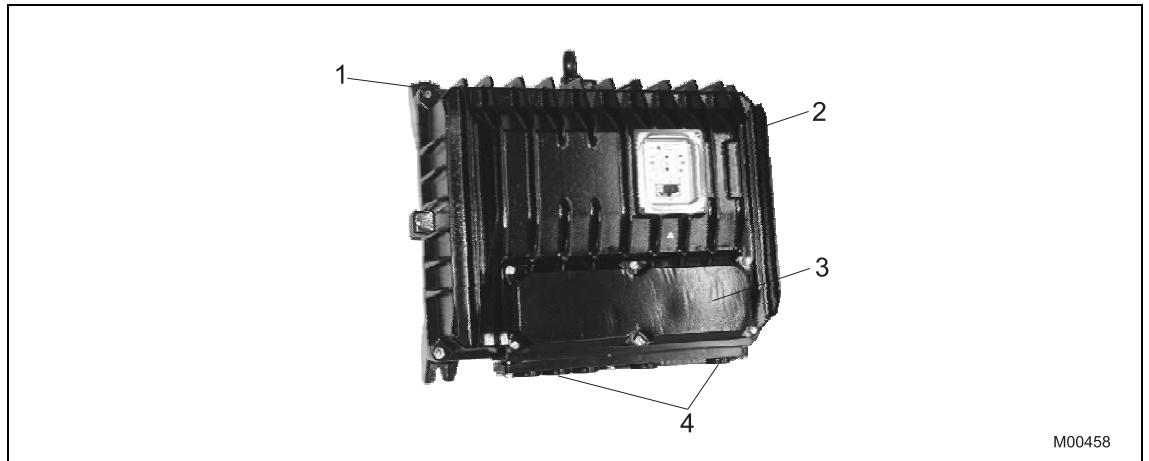

Fig. 9: EBS862

- 1 Electronic unit, lower section
- 2 Electronic unit cover
- 3 Cover for connection space
- 4 Holes for cable glands

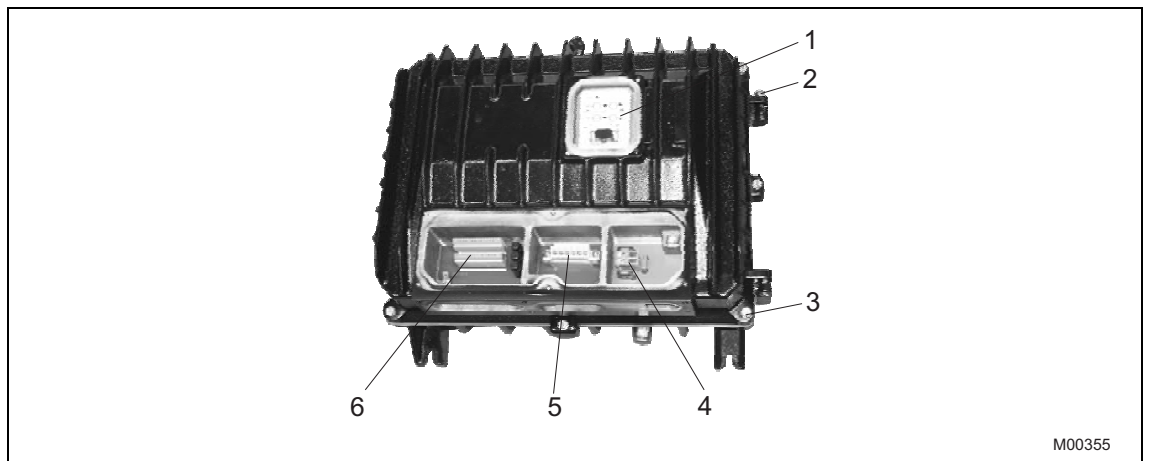

Fig. 10: EBS862 connection space

- 1 Commissioning and service field (ISF)
- 2 Hinge screws
- 3 Cover screws
- 4 Mains supply terminals
- 5 Motor terminals
- 6 Signal terminals

4 Installation

The electronic unit is installed in the vicinity of the drive outside the hazardous area. Screw-type terminals are used to connect the two modules on the actuator side and on the electronics side. The connections are made on the drive for the motor in the motor's Ex d connection space and for the actuating sensor using Ex e terminals in the actuating sensor's connection space.

A voltage trip unit is also required; this too is installed outside the hazardous area.



Important

Prior to installation or service activities, the electronic unit and actuator must be disconnected from the power supply and secured to prevent unintentional startup.

- It must also be possible to disconnect the electronic unit and actuator onsite.
- All signal and motor cables between the actuator and electronic unit must be shielded.
- The shielding must be placed on both housings when connecting the electronic unit and the actuator.

4.1 EBS852

1. Mount the module on the rack's vertical mounting rail with screws of property class 8.8 (tensile strength 800 N/mm^2 (116032 pounds/square inch), 640 N/mm^2 (92826 pounds/square inch)).
2. Provide adequate room for installation and make sure the actuator is accessible from all sides.
3. Cable entries point to the right.
4. Remove the cover from the connection space (Fig. 7, item 3).
5. Insert the cable into the cable entry and make the connection as shown on the connection diagram.
6. Check that the cable connections are properly seated, tighten the shield clamp, and replace the cover.

4.2 EBS862

**Important**

The total weight of the EBS862 electronic unit is 40 kg (88 lbs). For this reason, the electronic unit is equipped with a load-bearing eyelet. If, for technical reasons, the load-bearing eyelet cannot be used, the two halves of the housing can be installed separately.

Deinstallation the housing halves

1. Place the electronic unit on a horizontal surface.
2. Unscrew and remove the cover screws (Fig. 10, item 3).
3. Open the electronic unit.
4. Disconnect the internal plug connection between the housing halves.
5. Close the housing halves.
6. Unscrew and remove the hinge screw (Fig. 10, item 2).
7. Fold the front section forward while lifting it up and off the hinge pins. The cover of the electronic unit must be positioned in exactly the right place.

Mounting the housing halves

1. Set the housing halves down on the hinge pins and insert the screw into the upper pin. The cover of the electronic unit must be positioned in exactly the right place.
2. Restore the internal plug connection.
3. Close the housing, insert the cover screws (Fig. 10, item 3), and connect the cable.

Mounting

1. Mount the module on the rack's vertical mounting rail with screws of property class 8.8 (tensile strength 800 N/mm² (116032 pounds/square inch), yield strength 640 N/mm² (92826 pounds/square inch)).
2. Provide adequate room for installation and make sure the actuator is accessible from all sides.
3. The cable glands point down.
4. Remove the cover from the connection space (Fig. 9, item 3).
5. Insert the cable into the cable gland and make the connection as shown on the connection diagram.
6. Check that the cable connections are properly seated, tighten the cable gland, and replace the cover.

5 Electrical connection

Each actuator requires a Contrac electronic unit which is loaded with the type specific-software. Carefully consider the instructions for the electronic unit and compare the data labels of the actuator and the electronic unit in order to ensure a proper hard- and software assignment.

i

Instructions regarding use in Ex applications

The electrical connection between the Contrac electronic unit and the Contrac actuator can be established using the cable set (order code 695). The cable harness is not part of the Ex prototype test certificate and must therefore be tested for safety-relevant functionality within the complete installation by the installer or operator.

Consider the following issues:

- Consider the local regulation concerning the setup of electrical devices within hazardous areas. This applies particularly to EN 60079-14 for the setup of the screen and the potential compensation between the actuator, the electronic unit and the motor protection unit (see 1) in chapter "Cable shield", page 20 and chapter "Terminal connection diagrams", page 21 ff.
- For the connection of the motor and the position transmitter only use ATEX certified EEx e cable glands with IP 66 acc. to EN 50019.
- Use a cable socket or a solid wire, bended to a "U", to connect the motor cable.
- Ensure a proper strain relief for all cable connections.
- Protect all cables in the connections chambers against contact with metal components. Ensure a gap of at least 6 mm (0.24 inch) between all conductive components.
- Remove the desiccant in motor and position sensor.
- Do not change the factory-set position of the motor terminal chamber.
- Seal all not used cable entries with ATEX certified IP 66 plugs.
- Use a certified cut-off unit for the thermal motor monitoring. Permitted units are, e.g.:
 - ABB motor temperature monitoring unit SD241-B.
 - 3 RN 1011-1 CK 00 , Ex II (2) GD , PTB 01 ATEX 3218, Siemens

5.1 Actuator assignment and cable cross-sections
5.1.1 Rotary actuators

Electronic unit	Average power loss of the electronic unit	Max. current consumption ¹⁾		Actuator	Motor cable cross-section / Permissible cable length in m (ft) ²⁾									
		115 V	230 V		1.5 mm ² (16 AWG)	2.5 mm ² (14 AWG)	4 mm ² (12 AWG)	6 mm ² (10 AWG)	10 mm ² (8 AWG)					
EBS852	60 W	1.8 A	0.9 A	RHDE250-10	270 (866)	460 (1476)	-	-	-					
	75 W	2.2 A	1.1 A	RHDE500-10										
	60 W	5.0 A	2.5 A	RHDE800-10										
	80 W	5.0 A	2.5 A	RHDE1250-12										
	80 W	5.0 A	2.5 A	RHDE2500-25										
	80 W	5.8 A	2.7 A	RHDE4000-40										
EBS862	80 W	-	5.3 A	RHDE2500-10	160 (513)	270 (866)	430 (1380)	-	-					
	100 W	-	10.0 A	RHDE4000-10										
	115 W	-	8.0 A	RHDE8000-15						70 (225)	120 (385)	190 (610)	280 (898)	460 (1476)
	On request	-	12.5 A	RHDE16000-30										

1) At actuator rated power. Current consumption in positioning mode approx. 40 ... 50 % of I_{max} in each case.

2) Cable length between electronic unit and actuator. Signal cable cross-section 0.5 mm² (20 AWG).

5.1.2 Linear actuators

Electronic unit	Average power loss of the electronic unit	Max. current consumption ¹⁾		Actuator	Motor cable cross-section / Permissible cable length in m (ft) ²⁾				
		115 V	230 V		1.5 mm ² (16 AWG)	2.5 mm ² (14 AWG)	4 mm ² (12 AWG)	6 mm ² (10 AWG)	10 mm ² (8 AWG)
EBS852	55 W	2.2 A	1.1 A	RSDE10-5.0	270 (866)	460 (1476)	-	-	-
	60 W	3.6 A	1.8 A	RSDE10-10,0					
	60 W	3.6 A	1.8 A	RSDE20-5.0					
	75 W	4.8 A	2.4 A	RSDE20-7.5					
	75 W	5.0 A	2.5 A	RSDE50-3.0					
EBS862	100 W	-	6.4 A	RSDE50-10.0	160 (513)	270 (866)	430 (1380)	-	-

1) At actuator rated power. Current consumption in positioning mode approx. 40 ... 50 % of I_{max} in each case.

2) Cable length between electronic unit and actuator. Signal cable cross-section 0.5 mm² (20 AWG).

5.2 Cable shield

5.2.1 Signal part

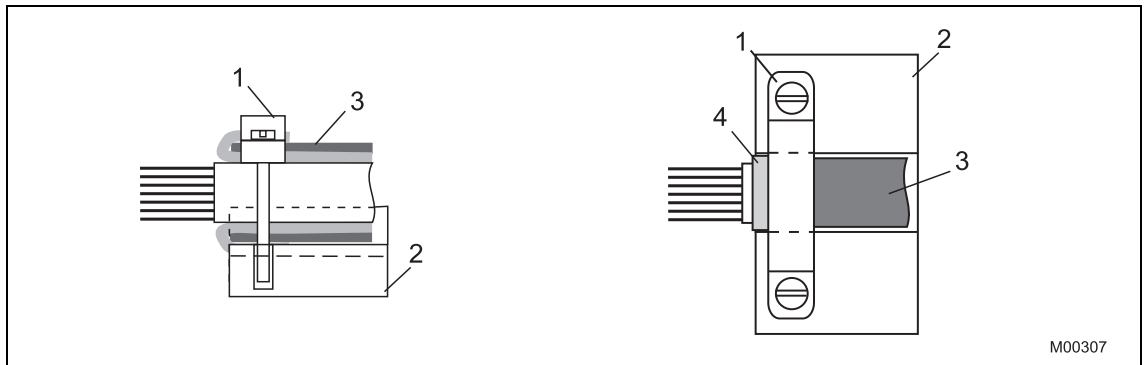

Fig. 11: Fitting the shield

1. Remove approx. 2 cm of cable sheathing (3) from the end of the cable.
2. Separate the shield and peel it back to its inner sheathing (4).
3. Push the cable through the cable gland and fasten with clamp (1).
4. Make sure that the shielding is touching the clamp and the electronic unit housing (2).

5.3 Terminal connection diagrams

5.3.1 Power Electronic Unit EBS852 (Contrac) / EBS862 (Contrac)



Important

The electrical connection is provided by terminals on the actuator and on the electronic unit.

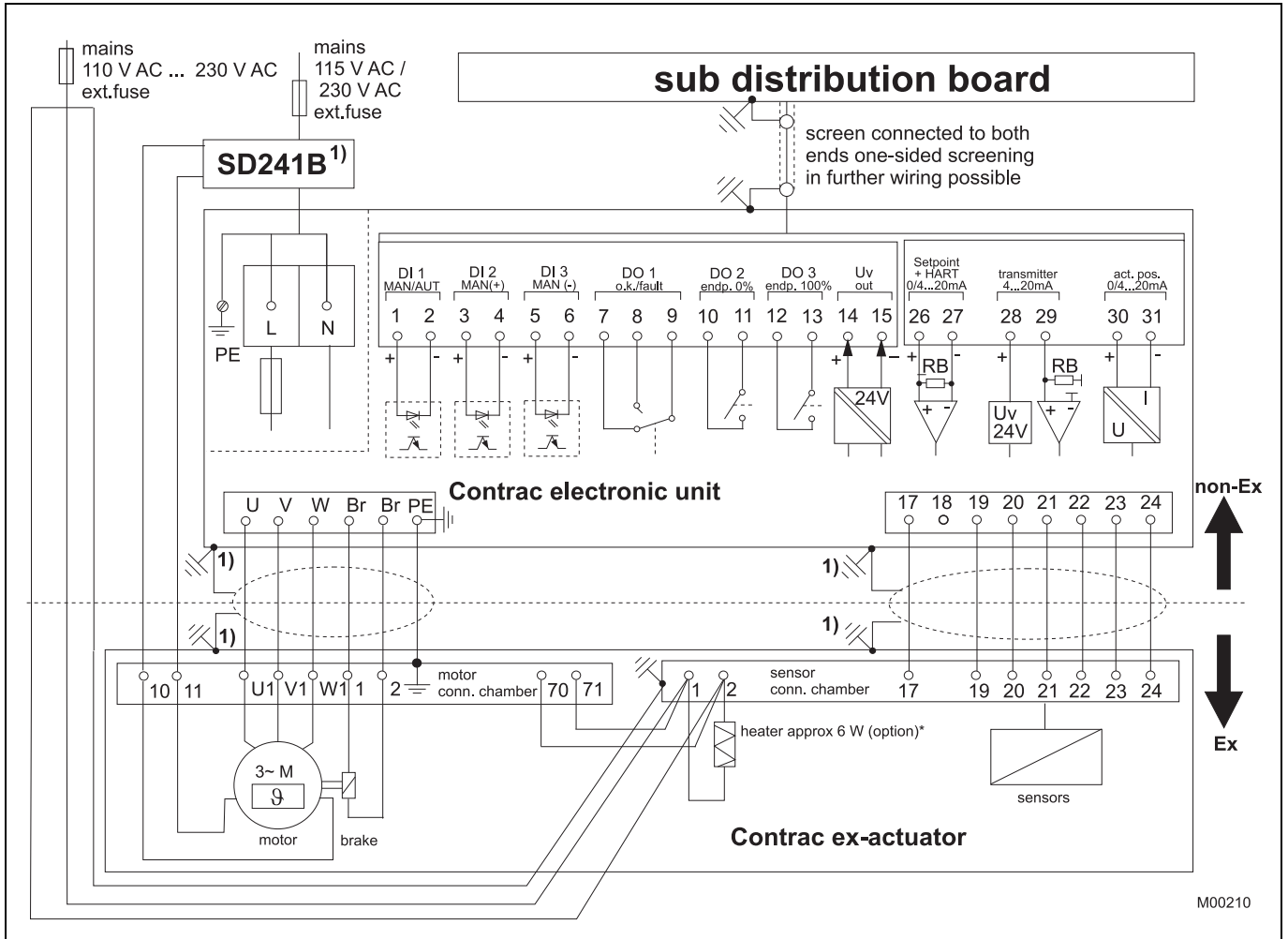

Fig. 12: Electrical connection: Ex actuator analog / digital



Important

* For separate heat supply, protect the heater with 2 ... max. 6 A medium time-lag fuses (e.g., Neozed D01CE14).



Important

For more information regarding footnote 1) see chapter Electrical connection, page 18.

5.4 Fuses

5.4.1 EBS852

Type	Installation location	UV=115 V	UV=230 V
Backup fuse	External	16 A; time-lag	
Mains fuse	F1, in connection space	12.5 A; time-lag	10 A; time-lag
Relay fuse for DO1, DO2, DO3	F2 ... F4, in connection space	3 x 0.2 A, medium time-lag	
Brake fuse	on printed board (power section)	0.315 A; medium time-lag	
DC link fuse	Power board	10 A, super fast-acting	

5.4.2 EBS862

Type	Installation location	UV=230 V
Backup fuse	External	35 A safety fuse ¹⁾ 16 A thermal circuit breaker
Relay fuse for DO1, DO2, DO3	F2 ... F4, in connection space	3 x 0.2 A, medium time-lag
Brake fuse	on printed board (power section)	0.315 A; medium time-lag
DC link fuse	Power board	15 A; medium time-lag

1) The 35 A safety fuse and the 16 A thermal circuit breaker are included in the delivery scope. The cable cross-section between the fuse and the electronic unit must be a minimum of 2.5 mm² (14 AWG).

5.4.3 External fuse for EBS862

In addition to the internal fuses, the EBS862 power electronic unit needs two other external fuses, which are delivered separately with the module.

They ensure the safe operation of the EBS862 power electronic under the special starting conditions.



Important

The cable cross-section between the fuse and the electronic unit must be a minimum of 2.5 mm².

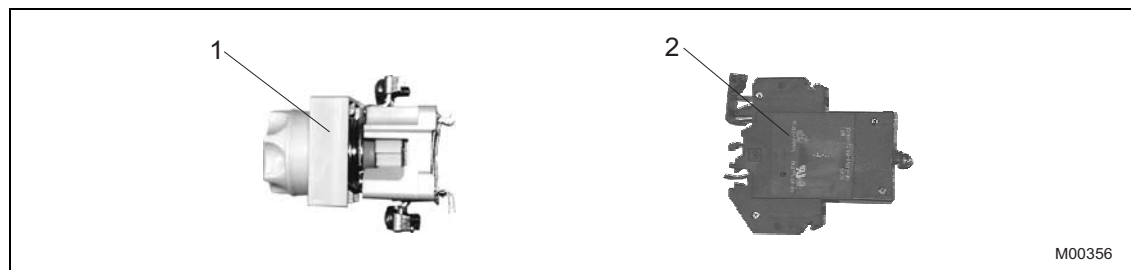
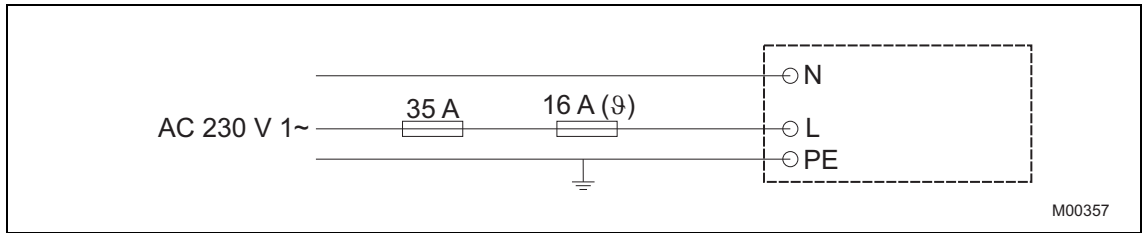

Fig. 13

- 1 External fuse: 35 A
- 2 External fuse: 16 A



M00357

Fig. 14

5.5 Connection elements

5.5.1 EBS852

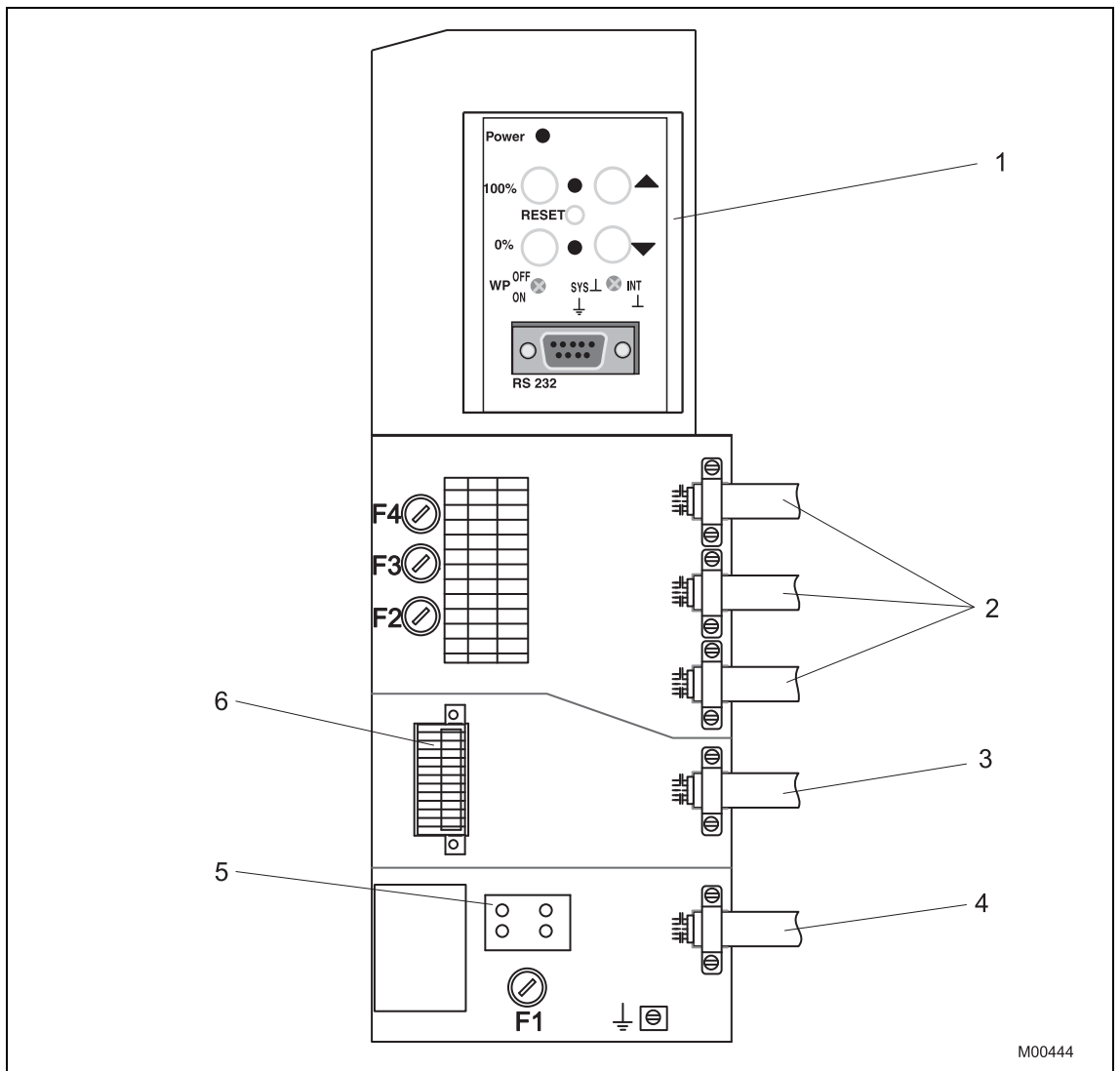

M00444

Fig. 15

- | | |
|---|------------|
| 1 Commissioning and service field (ISF) | 4 Mains |
| 2 Signal | 5 Terminal |
| 3 Motor | 6 Plug |

5.6 EBS862

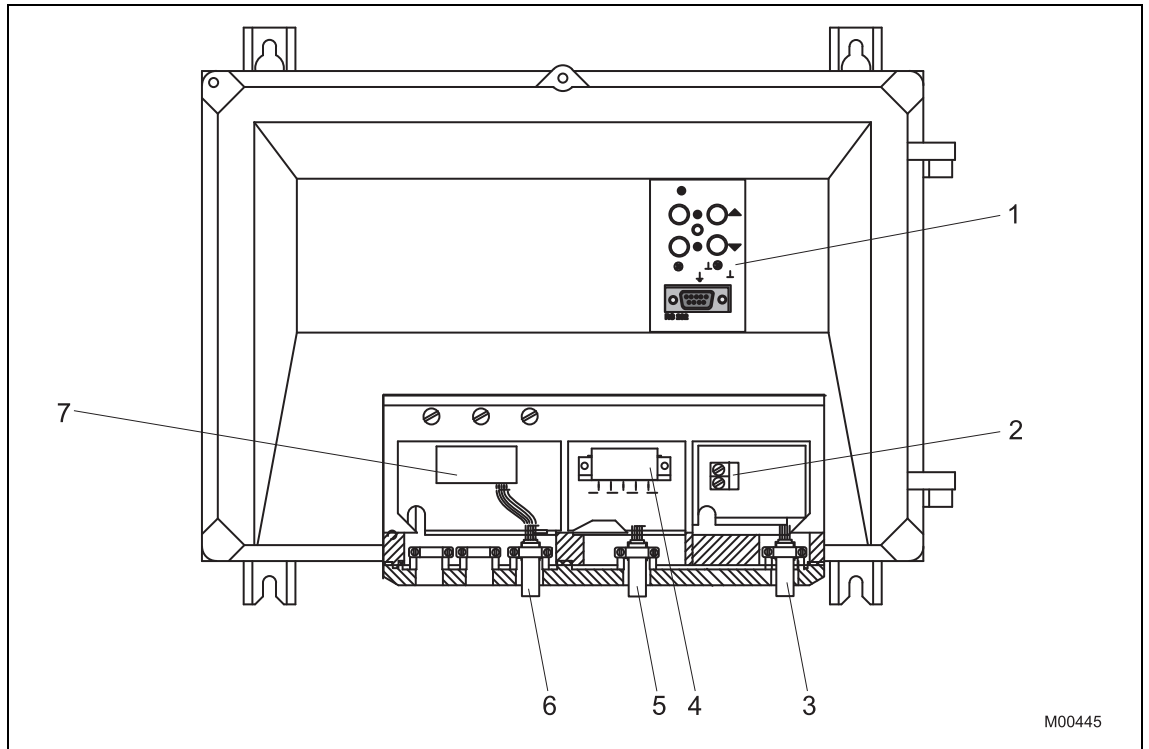

Fig. 16

- | | |
|---|-------------------------|
| 1 Commissioning and service field (ISF) | 5 Motor cable |
| 2 Terminals for mains connection | 6 Signal cable |
| 3 Mains cable | 7 Plug for signal cable |
| 4 Plug for motor cable | |

5.7 Cable guide

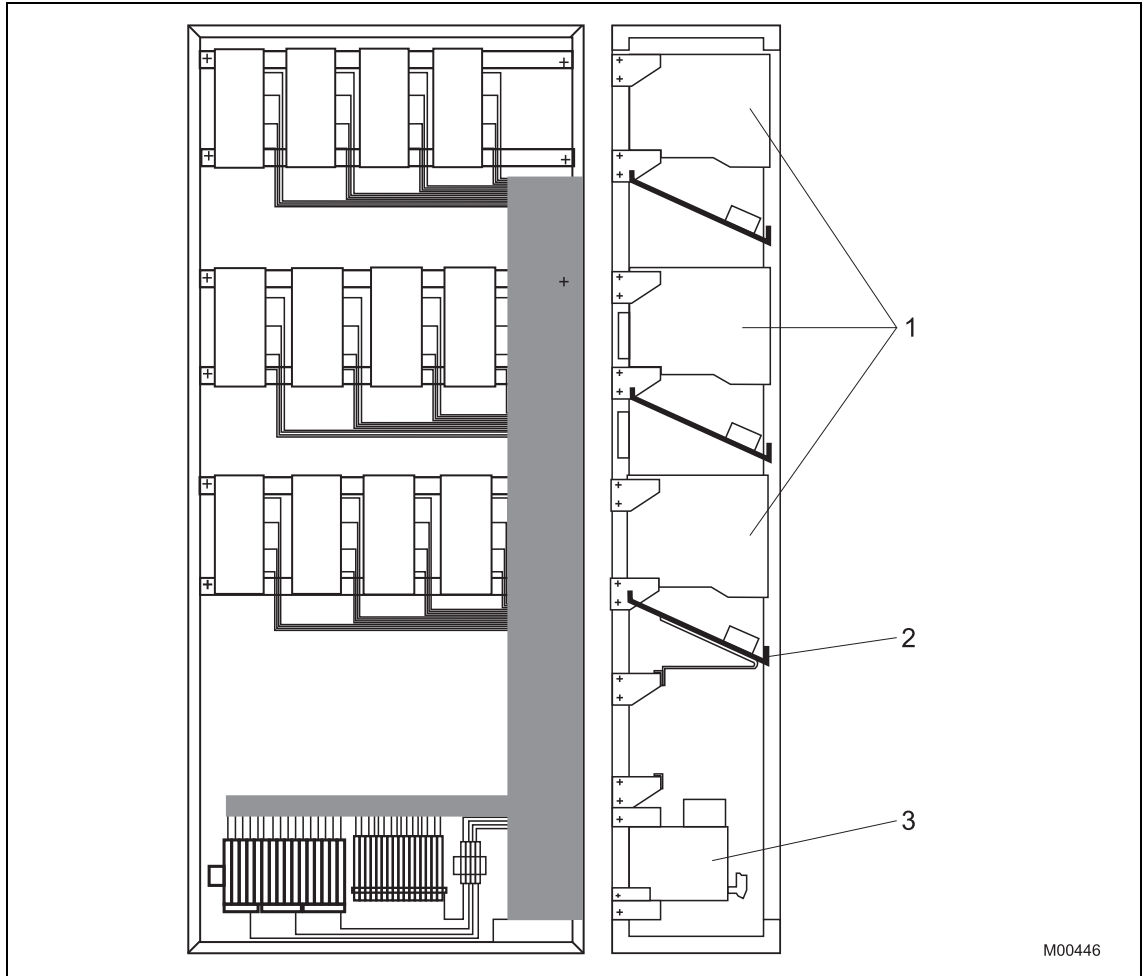

Fig. 17: Cable guide in rack

- 1 Electronic module
- 2 Thermally conductive plate
- 3 Mains distribution

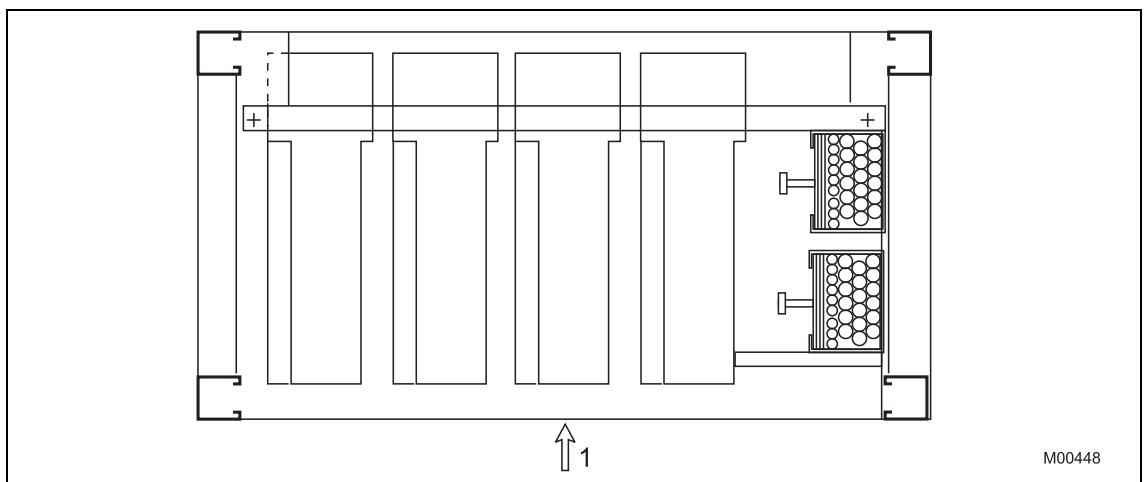

Fig. 18: Cable guide and electronic unit mounted in rack (view from above)

- 1 Front

5.8 Mains distribution

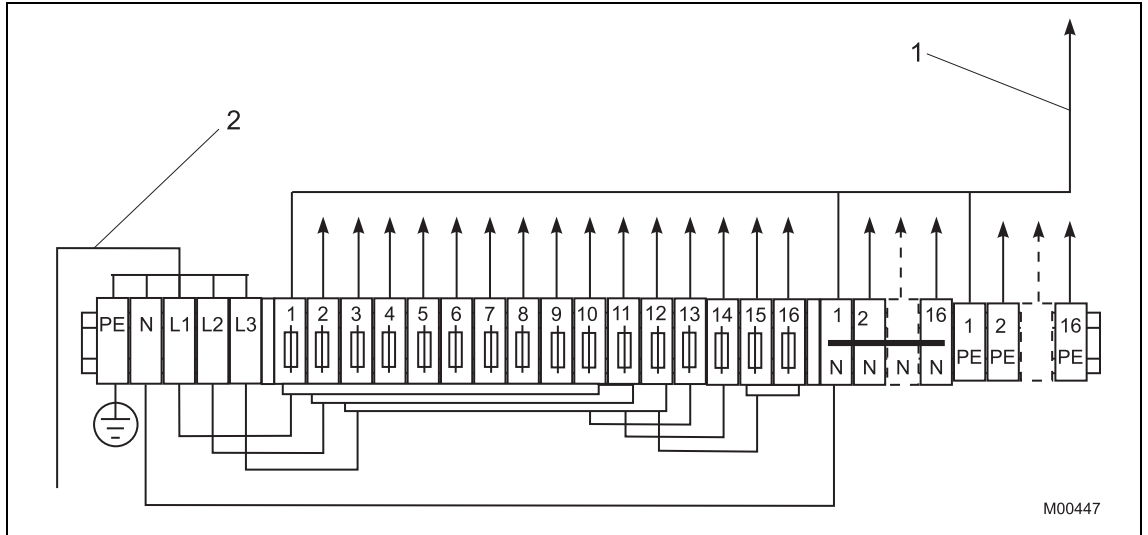

Fig. 19: Mains distribution for Contrac electronic unit in rack

- 1 Electronic unit
- 2 max. 16 mm² (6 AWG)

5.9 Cable routing in the connector

To prevent interference from electromagnetic fields, the signal and power cables in the connector housing must be routed and connected separately. A metal divider separates the two cable areas inside the connector. Attach the shielding as shown in Fig. 20.

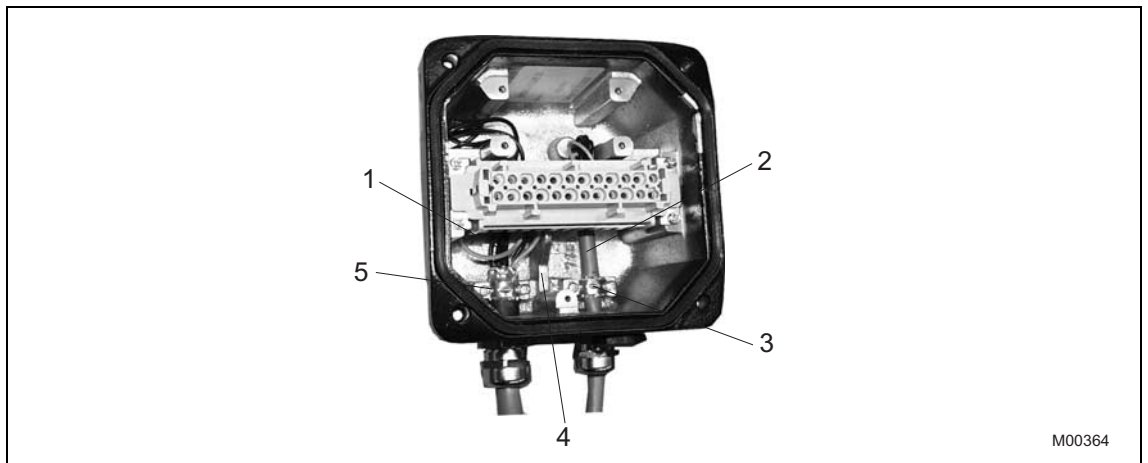

Fig. 20

- 1 Power cable
- 2 Signal cable
- 3 Shield
- 4 Separator
- 5 Shield

6 Local operation

6.1 General information on operation

The basic settings "Define end positions" and "Initial diagnosis" can be configured via the commissioning and service field (ISF). It can be used to adjust the actuator to the working area and set the direction without using a PC. The actuator can be further parametrized using a graphic user interface.

**Important**

The commissioning and service field is located on the electronic unit.

**Important**

Observe the information about using the engineering software Save & Restore or ECOM688 in chapter 2.2.

6.2 Operating elements of the service field (ISF)

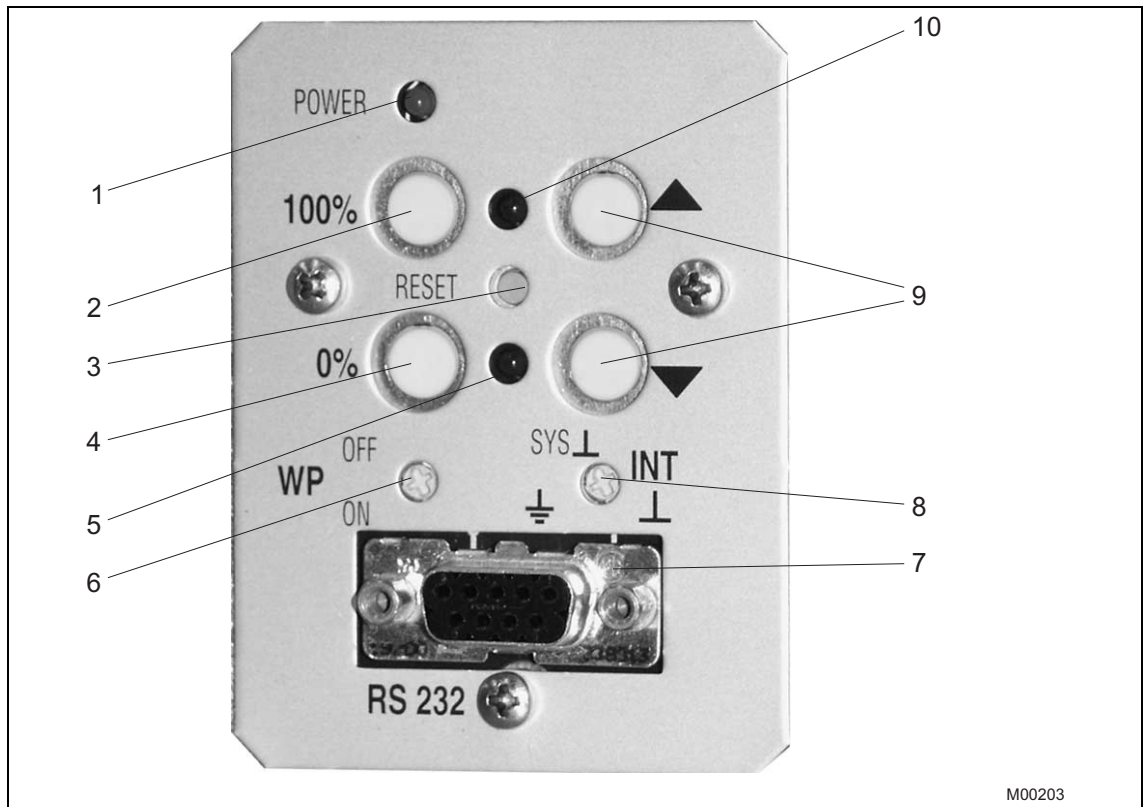

Fig. 21: Commissioning and service field (ISF)

- | | |
|--|---|
| <p>1 Power LED: Displays supply by line voltage.</p> <p>2 Accept button (100 %): Press to set the current position as 100 %; press in combination with the 4 button to end the adjustment process.</p> <p>3 Reset button: Press to restart the processor and delete any values assigned positions 0 % and 100 %.</p> <p>4 Accept button (0 %): Press to set the current position as 0 %; press in combination with the 2 button to end the adjustment process.</p> | <p>5 LED for 0 % position: Depending on the flash rate, this LED indicates either adjustment, position saved or error.</p> <p>6 Write-protection switch (default: ON).</p> <p>7 RS232 connector: Connection for a PC.</p> <p>8 Potential switch: Connection of reference potential either to system or protective ground (default setting: to system).</p> <p>9 Travel button: Press to initiate actuator movement.</p> <p>10 LED for 100 % position: Depending on the flash rate, this LED indicates either adjustment, position saved or error.</p> |
|--|---|

7 Commissioning and service field (ISF)

7.1 Typical commissioning with the service field (ISF)



Important

The operating range of the actuator is not factory-set. To set the actuator's operating range, set the write protection switch to "OFF". Once commissioning is complete, set the write protection switch to "ON".

For information about setting up the mechanical end stops, refer to the operating instructions for the relevant actuator.



Danger – Serious damage to health / risk to life

Make sure that the actuator can move without posing a risk.

7.1.1 Status

- The electronic unit is connected to the power supply and wired to the actuator.
- Move the write protection switch (6) to the "OFF" position.
- The electronic unit is in "MAN" mode; no signal at digital input 1 (DI 1).
- No error (if an error is pending, the LEDs will flash alternately at 4 Hz).

7.1.2 "Device setup" operating mode

1. Switch the electronic unit to "Device setup" mode. Press and hold down both travel buttons (9) at the same time for approx. 5 s until both LEDs (items 5 and 10 in Fig. 21) flash in sync at a rate of 4 Hz.



Important

Once commissioning is complete, set the write protection switch to "ON".

7.1.3 Setup via user interface

Context-sensitive online help can be called at any time via the graphical user interface.



Important

The RS232 communication cable provides a conductive ground connection between the computer and the Contrac electronic unit. If the PC is grounded, a ground loop may form in the system.

7.1.4 Defining the initial position (0% or 100%)

2. Use a travel button (9) to move to the desired position.
3. Press the Accept button (2) or (4) to accept the position; if successful, the corresponding LED will flash at a rate of 1 Hz. The other LED will continue to flash at approx. 4 Hz.

7.1.5 Defining the second position (0% or 100%)

4. Use a button (9) to move to the second position.
5. To accept the position, press the Accept button (2) or (4). If successful, both LEDs(5) and (10) will flash at a rate of approx. 1 Hz.

7.1.6 Saving your settings

6. Press both Accept buttons (2 + 4) to accept the settings. The LEDs (5 + 10) will stop flashing after a short period of time to indicate that the setup process is complete.
7. If the range selected for the actuator is too small, both LEDs will start to flash again at 4 Hz and the setup procedure will have to be repeated with a higher value (min. actuator travel).
(Information regarding actuator travel appears on the name plate.)

7.1.7 Correcting your settings

- If, after accepting the initial value for the settings, you need to make a correction, press the reset button (3) and repeat the setting procedure.
- If you need to make a correction after saving your settings, you will need to repeat the entire setup procedure from the beginning.

Function	Signals
Device setup	
Switch to Device setup: Press and hold down both travel buttons for approx. 5 s.	Both LEDs will then flash in sync at 4 Hz.
Approaching an end position: Use the appropriate button on the ISF.	Both LEDs will continue to flash at 4 Hz during actuator travel.
Save the initial end position: Press 0% or 100%.	The corresponding LED will flash at approx. 1 Hz, the others will continue to flash at 4 Hz.
Save the second end position: Press 0% or 100%.	The related LED will flash at approx. 1 Hz in sync with the first LED.
Finish setup: Press 0% and 100% at the same time.	Both LEDs will light up briefly and then go out.
Operation	
Normal operation: MAN / AUT	The LEDs are off.
Positioning via the button on the ISF takes priority over the control system.	The LEDs are off.
Error (both LEDs flashing alternately at 4 Hz)	
Reset: Resets error messages.	If there are no other errors pending, both LEDs will go out.
Reset if the operating range is overshot: Press and hold down both travel buttons for 5 s and then press the Reset button.	After approx. 5 s, the LEDs will stop flashing briefly. Once the reset has been performed, the electronic unit will be in Setup mode.



Important

After startup, it is recommended that you use the control system to operate the actuator and check both its response and its signaling behavior.

In order for the actuator to go into automatic mode after startup, there must be a 24 V DC signal at digital input 1 for actuators with active digital input functions (default setting).

If the digital function is switched off, the actuator will switch to automatic mode immediately on completion of the setup process.

8 Alarms / Errors

8.1 Definition

8.1.1 Alarms

The actuator or electronic unit is in a critical state (e.g., high temperature), which currently does not affect the actuator, electronic unit, process or persons. The actuator functions are available. Previous alarms are stored in the "Saved Alarms" area in the electronic unit. The graphic user interface use to output the stored alarms.

8.1.2 Error

The actuator or electronic unit is in a critical state, e.g., positioning time-out, which currently is impairing the actuator, electronic unit, process or persons. The actuator is switched off and the actuator functions are no longer available. Previous error messages are stored in the "Saved Errors" area in the electronic unit. Use the graphic user interface to output the stored errors. Error messages cannot be reset until the cause of the error has been eliminated.

8.2 Alarm diagram

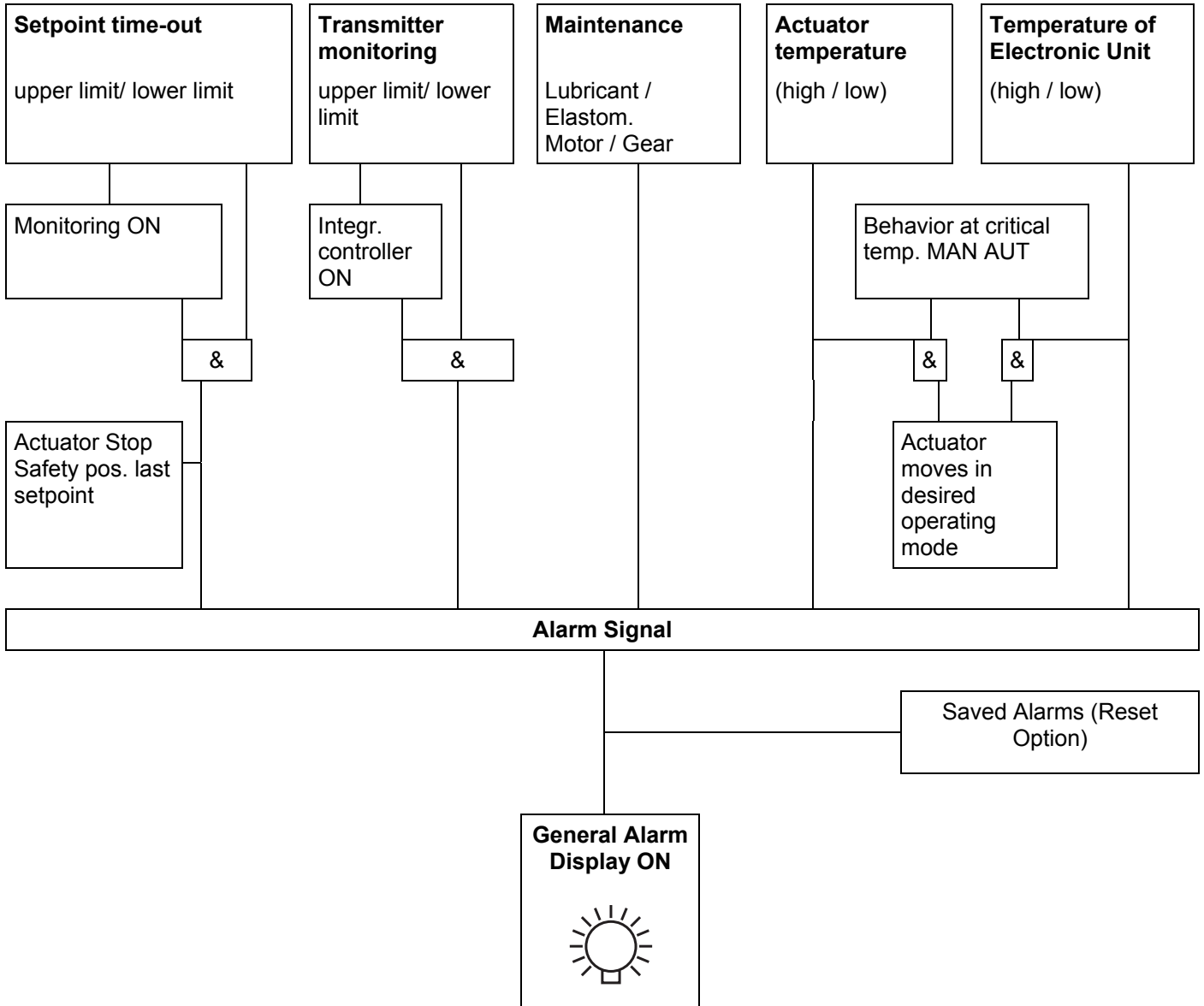

8.3 Error diagram

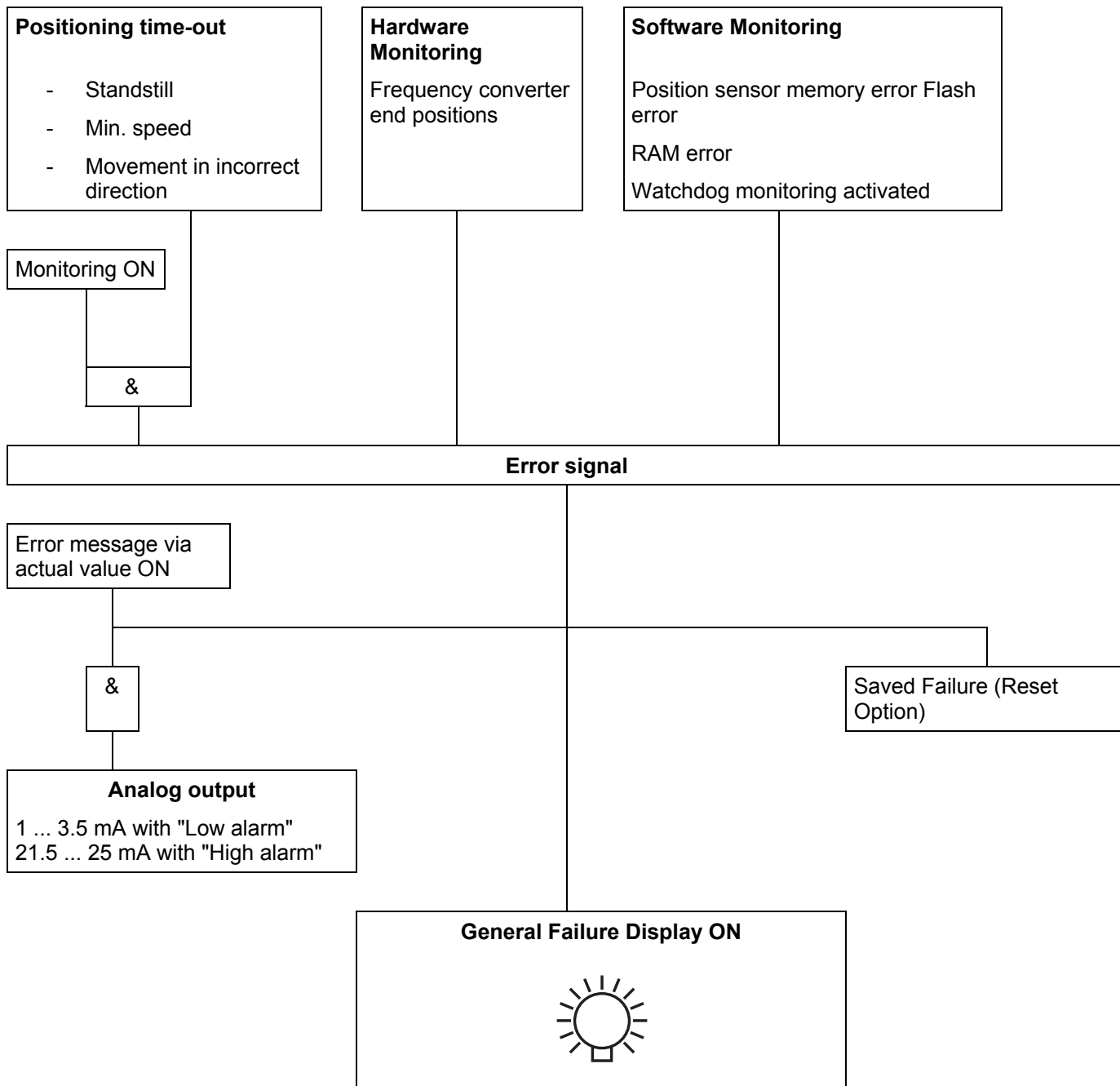

9 Trouble shooting

This chapter only covers hardware-related errors. For additional troubleshooting information, refer to the online help for the operator interface.

Error	Possible cause	Troubleshooting
Valve cannot be moved by actuator.	Failure either on the actuator or the valve (e.g., stuffing box tightened too much).	Disconnect actuator from valve. If the actuator moves, the valve is the possible cause. If the actuator does not move, the actuator is the possible cause.
The actuator does not respond.	Incorrect electronic unit or incorrect data record.	Compare information on name plates for actuator and electronic unit.
	Incorrectly configured electronic unit.	Check/update the settings for the parametrization software.
	No communication with the control system.	Check wiring.
	Incorrect wiring between actuator and electronic unit.	Check wiring.
	Defective motor/brake.	Check the winding resistance of the motor and brake. Check the brake lock.
	Binary inputs on the electronic unit are not wired.	Make connection.
	Brake does not release (no mechanical "click").	Check the brake air gap (approx. 0.25 mm (0.010 inch)) and electrical connection to the brake. Check winding resistance of the brake coil.
Actuator does not run in AUT mode, although "AUT" is selected in the user interface.	Digital input 1 (DI1) not wired.	Make connection. Check the software settings for the digital inputs.
LEDs in the commissioning and service panel (CSP) flash synchronously.	Actuator is not adjusted properly.	Adjust actuator.
LEDs flash alternately.	Electronic unit / drive malfunction.	Drive the actuator beyond the adjusted end position (either manually or using the pushbuttons on the CSP). Disconnect from valve, if necessary.
Malfunction when approaching the end position.	Actuator in limit range of positioning sensor.	Drive the actuator back into the operating range and connect it to the valve. Readjust the actuator for the operating range.

Technical data

10 Technical data

10.1 General information

	Power electronic unit	
	EBS852 (Contract)	EBS862 (Contract)
Protection class	IP 20	
Moisture	≤ 75% annual average (condensation not permitted)	
Rack air inlet temperature	0 ... 45 °C (32 ... 110 °F)	
Transport and storage temperature	-25 ... 70 °C (-15 ... 158 °F)	
Installation position	On vertical support, cable glands pointing to the right	On vertical support, cable glands pointing down
Coating	2-layer component epoxy (RAL 9005, black)	
Electrical connection	Mains supply via terminals; all other connections made via screw-type plug connectors	
Weight; approx.	11 kg (24 lb)	40 kg (88 lb)

10.2 Technical data for the EBS852

Supply voltage (standard actuators)	115 V AC (94 ... 130 V) or 230 V AC (190 ... 260 V); 47.5 ... 63 Hz; 1 Ph			
Supply voltage (Ex actuators)	115 V AC (94 ... 127 V) or 230 V AC (190 ... 253 V); 47.5 ... 63 Hz; 1 Ph			
Current at electronic unit [A] (115 V AC / 230 V AC)		$I_{max.}$ at 115 V	$I_{max.}$ at 230 V	$I_{pos.}$ (115 V + 230 V) approx. 40 ... 50 % of $I_{max.}$
	RHD(E)250-10	1.8 A	0.9 A	
	RHD(E)500-10	2.2 A	1.1 A	
	RHD(E)800-10	5.0 A	2.5 A	
	RHD(E)1250-12	5.0 A	2.5 A	
	RHD(E)2500-25	5.0 A	2.5 A	
	RHD(E)4000-40	5.8 A	2.7 A	
	RHD(E)8000-80	5.0 A	2.5 A	
	RSD(E)10-5.0	2.2 A	1.1 A	
	RSD(E)10-10.0	3.6 A	1.8 A	
	RSD(E)20-5.0	3.6 A	1.8 A	
	RSD(E)20-7.5	4.8 A	2.4 A	
	RSD(E)50-3.0	5.0 A	2.5 A	
	RSD100-1.5	5.0 A	2.5 A	
	RSD200-0.7	5.0 A	2.5 A	
External fuse for power electronic unit	16 A; time-lag			
External fuse anti-condensation heater	2 ... 6 A; medium time-lag			
Analog input	0 / 4 ... 20 mA			
Analog output	0 / 4 ... 20 mA, galvanically isolated			
3 binary inputs BE 1 ... BE 3 (DI 1 ... DI 3)	Binary 0: -3 ... 5 V or open, galvanically separated Binary 1: 12 ... 35 V, galvanically separated			
3 binary outputs BA 1 ... BA 3 (DO 1 ... DO 3)	Potential free relay contact, max. 60 V, 150 mA			
Digital communication	RS232 for commissioning and service, optionally FSK / HART®			
Default settings	Behavior in 0 / 100 % end position: Hold with rated torque / end positions set point function: linear, set point = position value set point input: 4 ... 20 mA function selection: positioner, parameter: setpoint actual value: 4 ... 20 mA digital input: BE 1 (DI 1) M / A selection; BE 2 / 3 (DI 2 / 3) manual intervention +/- digital output: BA 1 (DO 1) ready for operation; BA 2 / 3 (DO 2 / 3) end position signal 0 / 100 % positioning time-out: not activated for standard actuators always activated for actuators in explosion proof design			
Voltage output U_V	24 V, 15 mA, galvanically isolated; e.g., for scanning external contacts			
Transmitter (optional)	Supply for 2-wire transmitter with activated process controller in Contract			
Individual settings	See data sheet 10/68-2.40 or upon request			

10.3 Technical data for the EBS862

Supply voltage (standard actuators)	230 V AC (190 ... 260 V); 47.5 ... 63 Hz; 1 Ph		
Supply voltage (Ex actuators)	230 V AC (190 ... 253 V); 47.5 ... 63 Hz; 1 Ph		
Current at electronic unit [A] (AC 230 V AC)		$I_{max.}$ at 230 V	$I_{pos.}$ (230 V) approx. 40 ... 50% of $I_{max.}$
	RHD(E)2500-10	5.3 A	
	RHD(E)4000-10	10.0 A	
	RHD8000-12	8.0 A	
	RHDE8000-15	8.0 A	
	RHD(E)16000-30	12.5 A	
	RSD(E)50-10.0	6.4 A	
	RSD100-10.0	12.5 A	
	RSD200-5.0	13.0 A	
External fuse	safety fuse 35 A (Lindner) + thermal circuit breaker 16 A (ETA) (fuse and circuit breaker are part of shipment)		
External fuse for heat supply	2 ... 6 A; medium time-lag		
Analog input	0 / 4 ... 20 mA		
Analog output	0 / 4 ... 20 mA, galvanically isolated		
3 binary inputs BE 1 ... BE 3 (DI 1 ... DI 3)	Binary 0: -3 ... 5 V or open, galvanically separated Binary 1: 12 ... 35 V, galvanically separated		
3 binary outputs BA 1 ... BA 3 (DO 1 ... DO 3)	Potential free relay contact, max. 60 V, 150 mA		
Digital communication	RS232 for commissioning and service, optionally FSK / HART®		
Default settings	Behavior in 0 / 100 % end position:	Hold with rated torque / end positions	
	set point function:	linear, set point = position value	
	set point input:	4 ... 20 mA	
	function selection:	positioner, parameter: setpoint	
	actual value:	4 ... 20 mA	
	digital input:	BE 1 (DI 1) M / A selection; BE 2 / 3 (DI 2 / 3) manual intervention +/-	
	digital output:	BA 1 (DO 1) ready for operation; BA 2 / 3 (DO 2 / 3) end position signal 0 / 100 %	
	positioning time-out	not activated for standard actuators always activated for actuators in explosion proof design	
Voltage output U_v	24 V, 15 mA, galvanically isolated; e.g., for scanning external contacts		
Transmitter (optional)	Supply for 2-wire transmitter with activated process controller in Contrac		
Individual settings	See data sheet 10/68-2.40 or upon request		

11 Appendix

11.1 Permits and certifications

	Symbol	Description
CE mark		By placing the CE mark on the model plate, ABB Automation Products GmbH declares its conformance with the following directives: <ul style="list-style-type: none">- EMC directive 89/336/EEC.- Machinery directive 2006/42/EC

**Important**

All documentation, declarations of conformity and certificates are available in the download area of ABB.

www.abb.com/instrumentation

Statement about the contamination of devices and components

The repair and/or maintenance of devices and components will only be performed when a completely filled out explanation is present.

Otherwise, the shipment can be rejected. This explanation may only be filled out and signed by authorized specialist personnel of the operator.

Customer details:

Company: _____

Address: _____

Contact person: _____

Telephone: _____

Fax: _____

E-Mail: _____

Device details:

Type: _____

Serial no.: _____

Reason for the return/description of the defect: _____

 _____**Was this device used for working with substances which pose a threat or health risk?** Yes No

If yes, which type of contamination (please place an X next to the applicable items)

biological	<input type="checkbox"/>	corrosive/irritating	<input type="checkbox"/>	combustible (highly/extremely combustible)	<input type="checkbox"/>
toxic	<input type="checkbox"/>	explosive	<input type="checkbox"/>	other harmful substances	<input type="checkbox"/>
radioactive	<input type="checkbox"/>				

Which substances have had contact with the device?

1. _____

2. _____

3. _____

We hereby certify that the devices/parts shipped were cleaned and are free from any dangerous or poisonous materials.

City, Date_____
Signature and company stamp

12 Index

A	
Actuator assignment	19
Alarm diagram	33
Alarms	32
Alarms / Errors	32
Appendix	39
C	
Cable cross-section	22
Cable cross-sections	19
Cable guide	25
Cable routing in the connector	26
Cable shield	20
CE mark	39
Commissioning and service field (ISF)	29
Connection elements	23
Contrac electronic unit	18
D	
Design and function	13
Disposal	10
Downloads	39
E	
ECOM688	12
Electrical connection	18, 21
Electrical installation safety information	11
EMC directive	39
Error	32
Error diagram	34
Ex applications	18
Explosion-protection safety precautions	12
External fuse for EBS862	22
External fuses	22
F	
Fuses	22
G	
General information	37
General information on operation	27
General Safety Information	5
I	
Installation	16
Installation safety information	11
Interference	26
Internal fuses	22
L	
Labels and symbols	6
Local operation	27
M	
Mains distribution	26
Modules	14
Mounting	17
Mounting the housing halves	17
N	
Name plate for EBS852 electronic unit	7
Name plate for EBS862 electronic unit	8
O	
Operating elements of the service field (ISF)	28
Operating safety information	11
Operation via frequency transformer	12
Operator liability	9
P	
Permits and certifications	39
Personnel qualification	9
Power Electronic Unit EBS852 (Contrac) / EBS862 (Contrac)	21
Proper use	5
R	
Returning devices	9
S	
Safety	5
Separating the housing halves	17
Storage conditions	10
Symbols and warnings	6
T	
Technical data	37
Technical data for the EBS852	37
Technical data for the EBS862	38

Technical limits	6	Typical commissioning with the service field (ISF) ..	29
Terminal connection diagrams.....	21	W	
Transport safety information	10	Warranty provision	6
Trouble shooting	35	WEEE directive	10

ABB has Sales & Customer Support
expertise in over 100 countries worldwide.

www.abb.com/instrumentation

The Company's policy is one of continuous product
improvement and the right is reserved to modify the
information contained herein without notice.

Printed in the Fed. Rep. of Germany (07.2008)

© ABB 2008

3KXE181004R4201



ABB Limited

Salterbeck Trading Estate
Workington, Cumbria
CA14 5DS
UK
Tel: +44 (0)1946 830 611
Fax: +44 (0)1946 832 661

ABB Inc.

125 E. County Line Road
Warminster, PA 18974
USA
Tel: +1 215 674 6000
Fax: +1 215 674 7183

ABB Automation Products GmbH

Schillerstr. 72
32425 Minden
Germany
Tel: +49 551 905-534
Fax: +49 551 905-555
CCC-support.deapr@de.abb.com