Instrumentation solutions



- Electrical actuators for positioning vanes and valves in the process control loop
- Combining durability and precision positioning
- Suitable for continuous positioning and three-step control

1	Design and function	3
1.1	System components	3
1.2	Type code	5
2	Component diagram	6
2.1	Part-turn actuators	6
2.2	Linear actuators	6
2.3	Power electronic units	7
2.4	Motor temperature monitoring unit	7
3	Typical applications	8
4	Features	9
5	Electrical connection	10
5.1	EBN853	10
5.2	EBS852, EBS862, EBN861	12
6	Technical data	14
6.1	Part-turn actuators	14
6.2	Linear actuators	15
6.3	Power electronic unit for field installation	15
6.4	Power electronic unit for rack installation	16
6.5	Motor temperature monitoring unit	16

1 Design and function

Functionality

A special power electronic unit controls the actuator. The electronic unit serves as the interface between actuator and control system.

During continuous positioning the power electronic unit varies the motor torque steplessly until the actuator force and the restoring process forces are balanced. High response sensitivity and high positioning accuracy with short stroke time ensure excellent control quality and a long actuator life.

1.1 System components

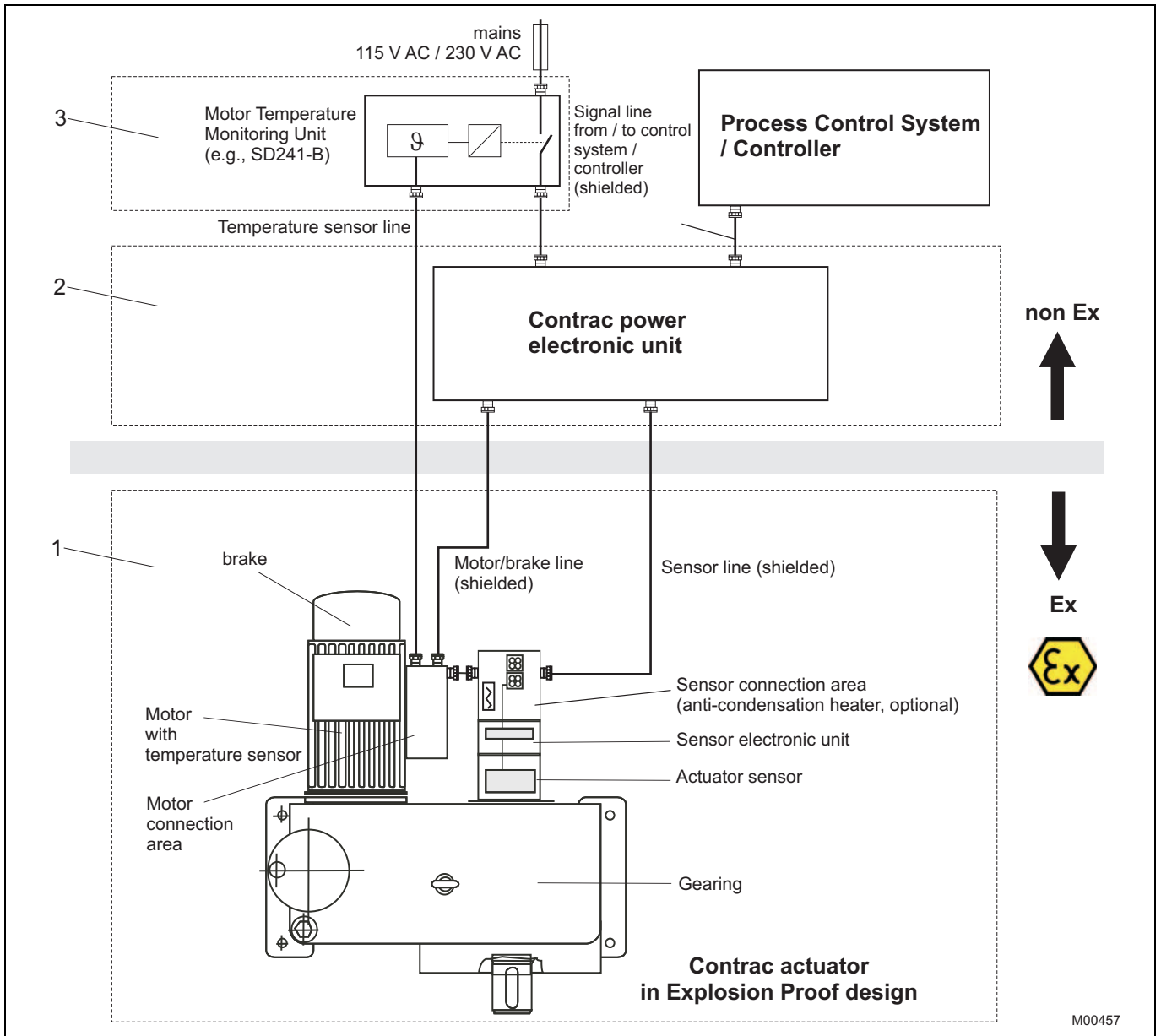
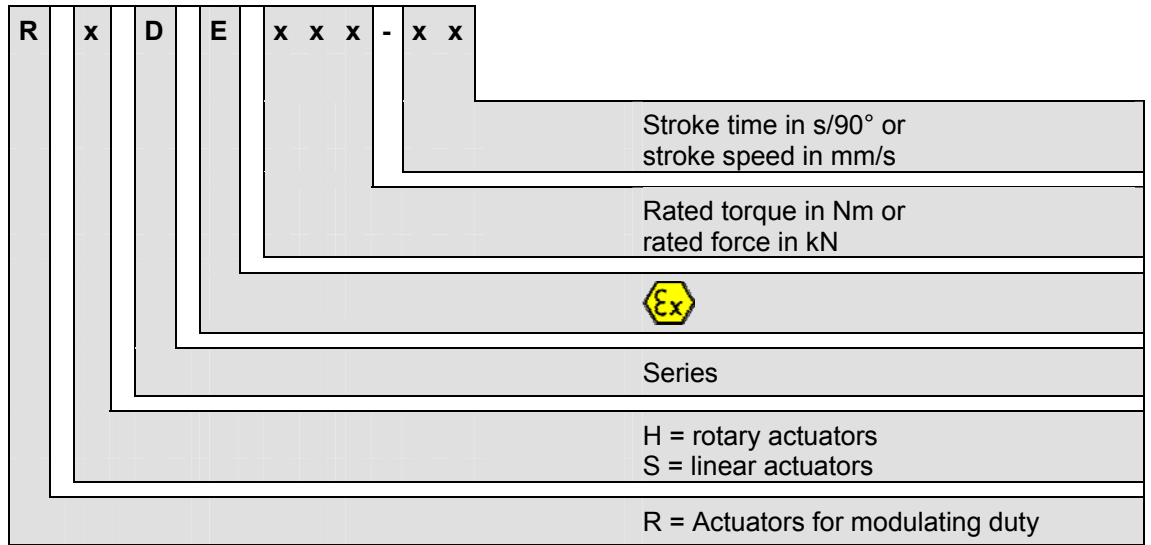

Fig. 1

No.	Module / Type			
1	Rotary actuator	Rated torque (adjustable)	Rated speed (adjustable)	Rated actuator travel (adjustable)
	RHDE250-10	250 Nm	10s/90°	90°
	RHDE500-10 RHDE800-10	500 Nm 800 Nm	10s/90° 10s/90°	90°
	RHDE1250-12 RHDE2500-10 RHDE2500-25	1250 Nm 2500 Nm 2500 Nm	12s/90° 10s/90° 25s/90°	90°
	RHDE4000-10 RHDE4000-40	4000 Nm	10s/90° 40s/90°	90°
	RHDE8000-15 RHDE8000-80	8000 Nm	15s/90° 80s/90°	90°
	RHDE16000-30	16000 Nm	30s/90°	90°
	Linear actuator	Rated force (adjustable)	Rated speed (adjustable)	Max. actuator travel (adjustable)
	RSDE10-5 RSDE10-10 RSDE20-5 RSDE20-7,5	10 kN 10 kN 20 kN 20 kN	5.0 mm/s 10.0 mm/s 5.0 mm/s 7.5 mm/s	100/300 mm
	RSDE50-3 RSDE50-10	50 kN	3.0 mm/s 10.0 mm/s	120/300 mm
2	Contrac power electronic unit	Mounting		
	EBN853 / EBN861	For field mounting (IP 66)		
	EBS852 / EBS862	For rack installation (IP 20)		
3	Motor temperature monitoring	For field or rack mounting (IP 54)		
	SD241-B			

1.2 Type code

Actuators



Power electronic unit

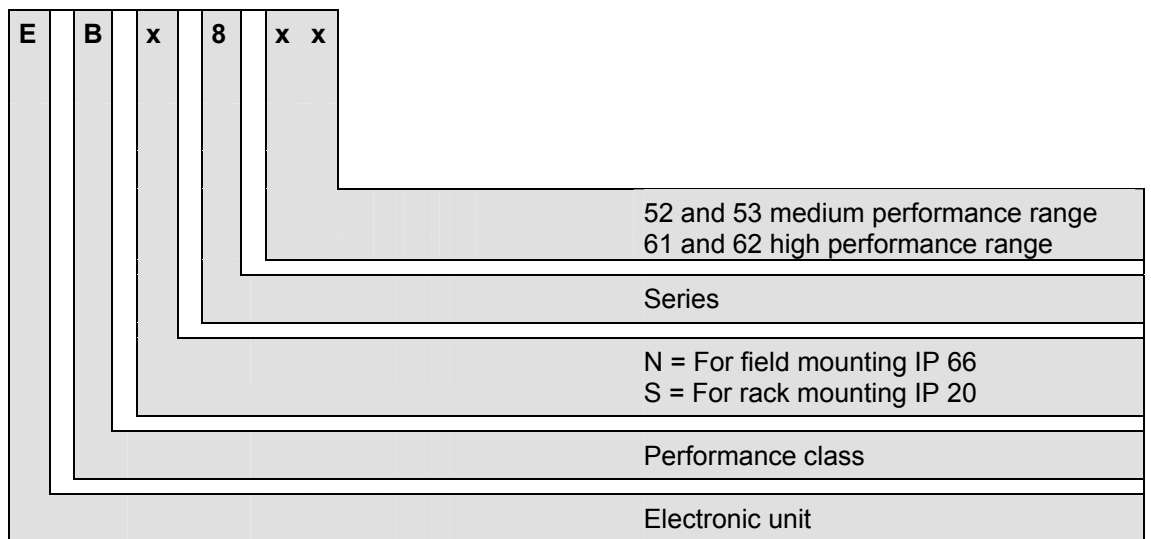

Motor temperature monitoring unit



2 Component diagram

2.1 Part-turn actuators

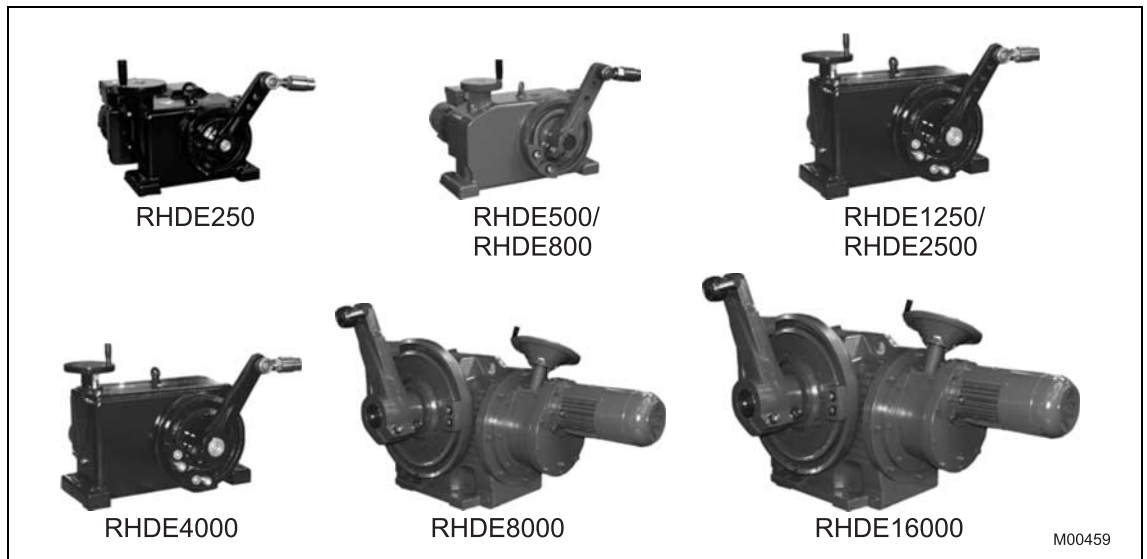

Fig. 2

2.2 Linear actuators

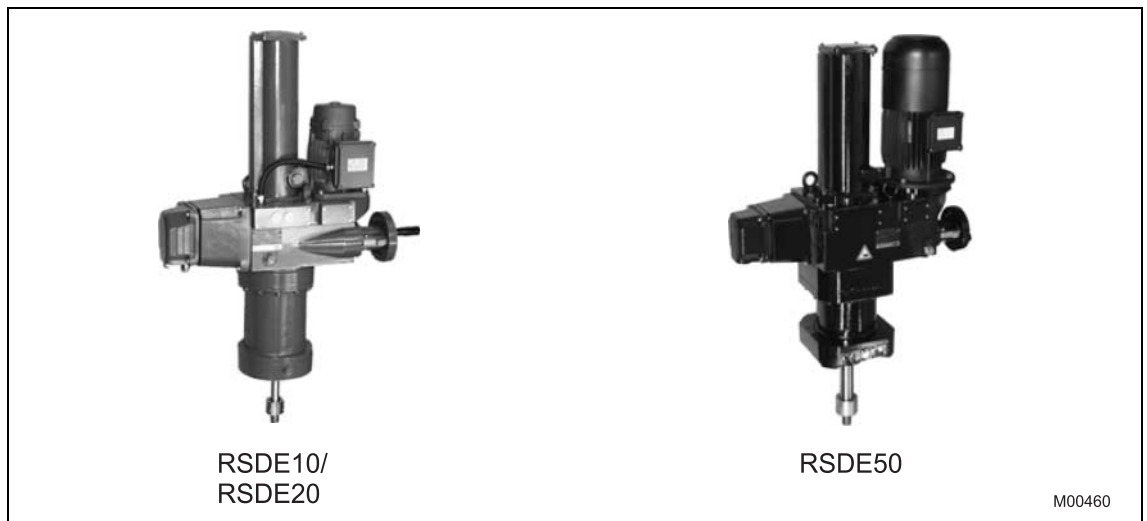

Fig. 3

2.3 Power electronic units

Fig. 4

2.4 Motor temperature monitoring unit

Fig. 5

3 Typical applications

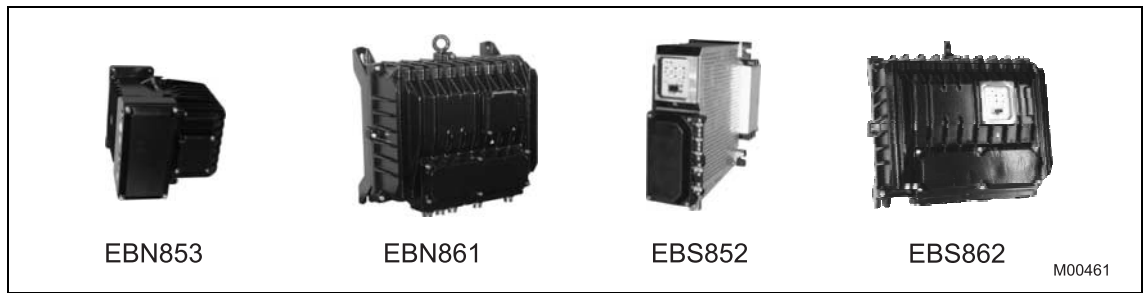
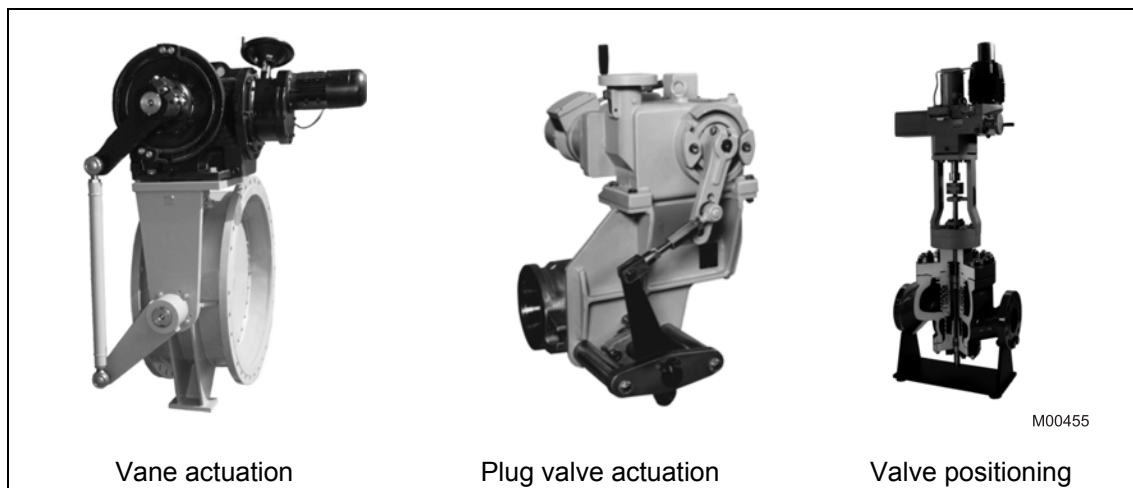

Fig. 6

4 Features

- Electrical actuators for positioning vanes and valves in the process control loop
- Minimum maintenance costs
- Combining durability and precision positioning
- Suitable for continuous positioning and three-step control
- Stallproof without the need for position-dependent or torque-dependent switch-off
- Explosion protection acc. to ATEX and
- Rostechnadzor / GOST
- Three-phase asynchronous motor, hermetically sealed
- Connection spaces with increased safety
- Highly efficient and sturdy gear unit
- Adjustable mechanical limit stops for defined operating range
- Handwheel for emergency operation
- Integrated position and temperature sensors
- Signal and power input via separate microprocessor-controlled power electronics
- Actuators for complex control tasks
- High positioning accuracy
- Maximum reliability and service life thanks to:
 - Continuous positioning
 - Sturdy oil-lubricated gear unit; stallproof
 - Continuous duty with 100% ON time (S9 acc. to IEC 60034-1 / EN 60034-1)
 - Reliable frequency converter electronics
 - Activation via conventional signals (with HART) or fieldbus
 - Additional functions (e.g. adjustment, diagnostics, maintenance, process controller)

5 Electrical connection

5.1 EBN853



Important

The electrical connection is made via screw-type terminals on the actuator and on the electronic unit.

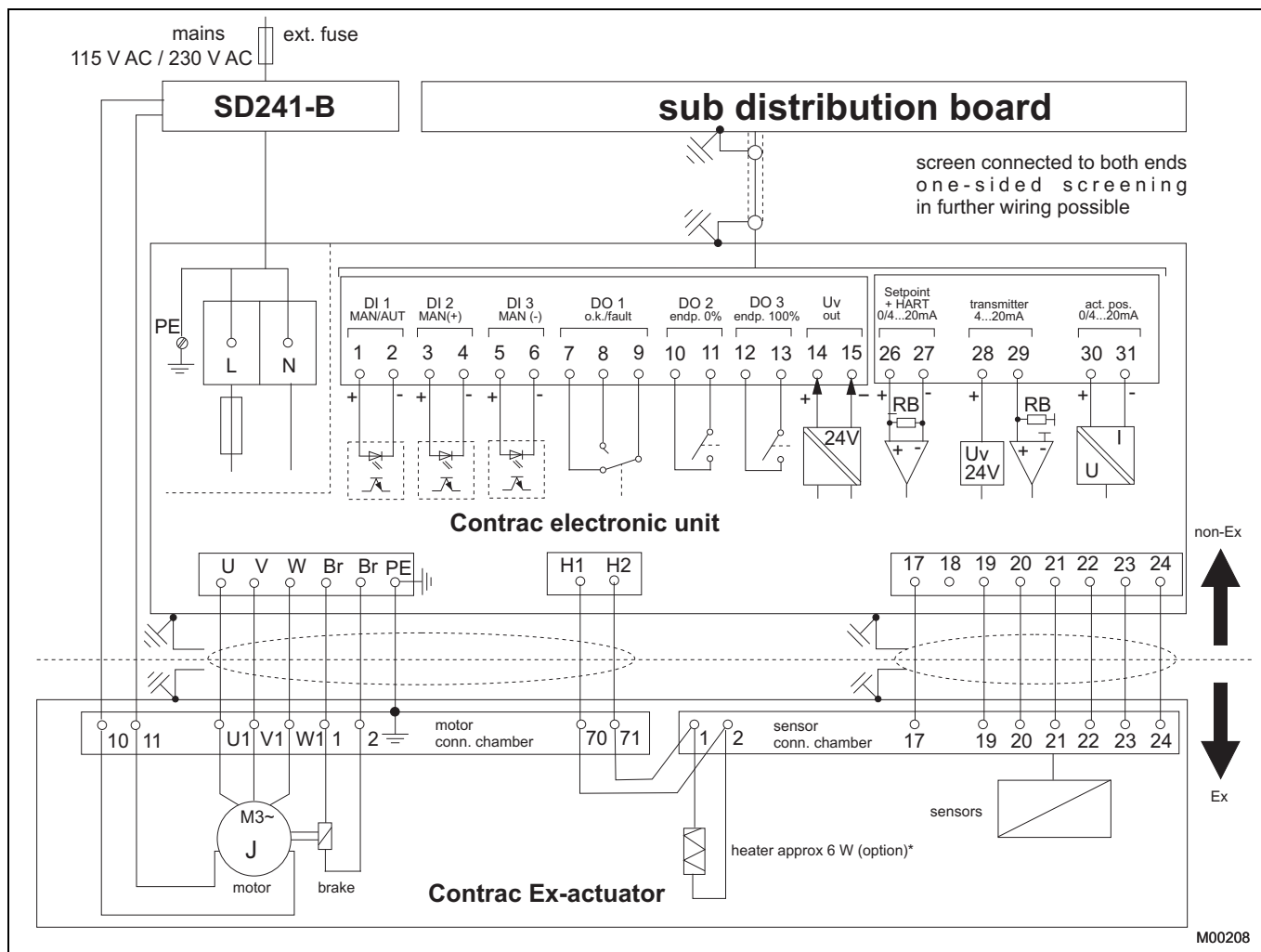

Fig. 7: Electrical connection: Ex actuator analog / digital

M00208

PROFIBUS DP

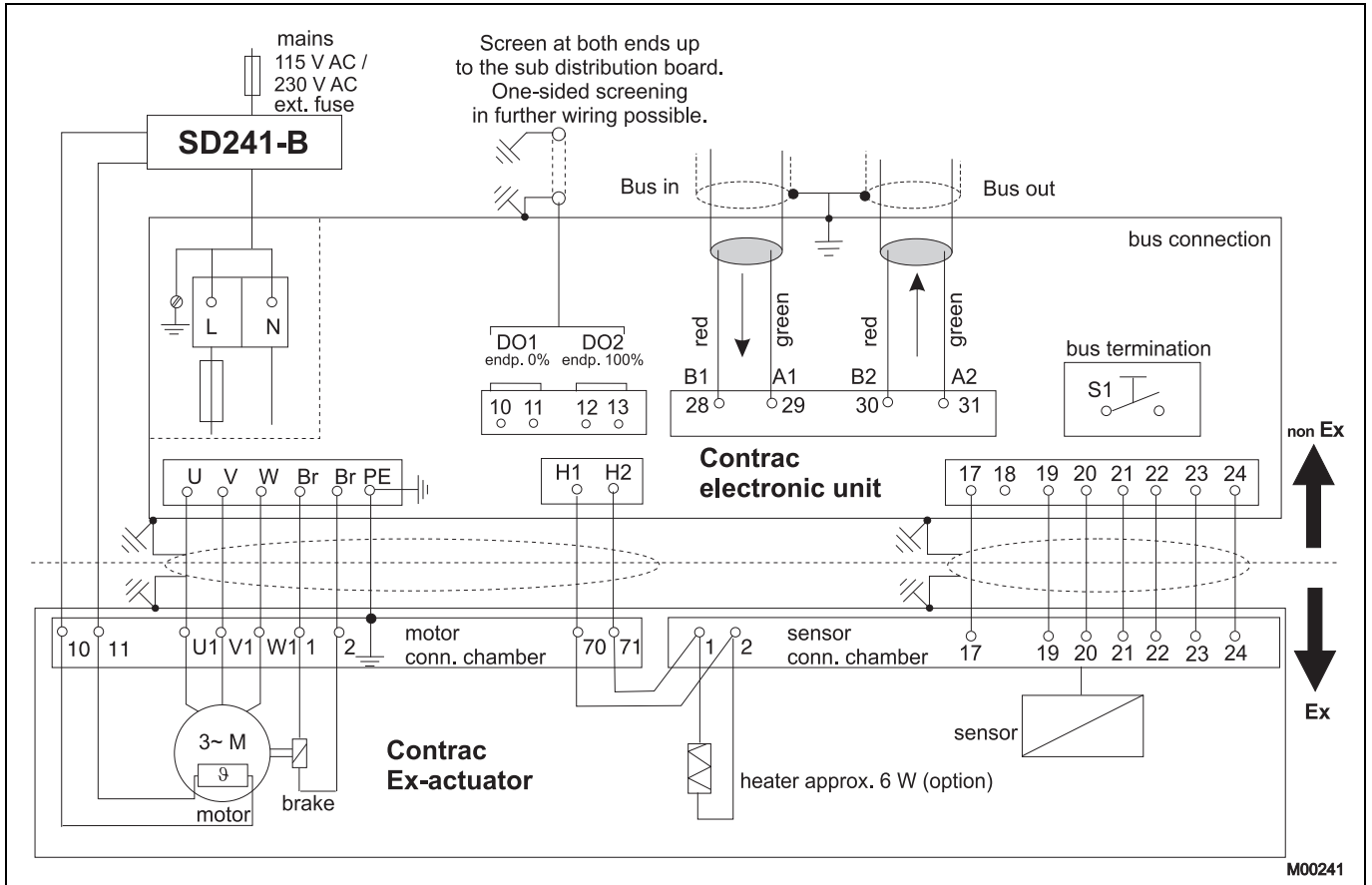

Fig. 8: Electrical connection: PROFIBUS DP option

Electrical connection

5.2 EBS852, EBS862, EBN861



Important

The electrical connection is made via screw-type terminals on the actuator and on the electronic unit.

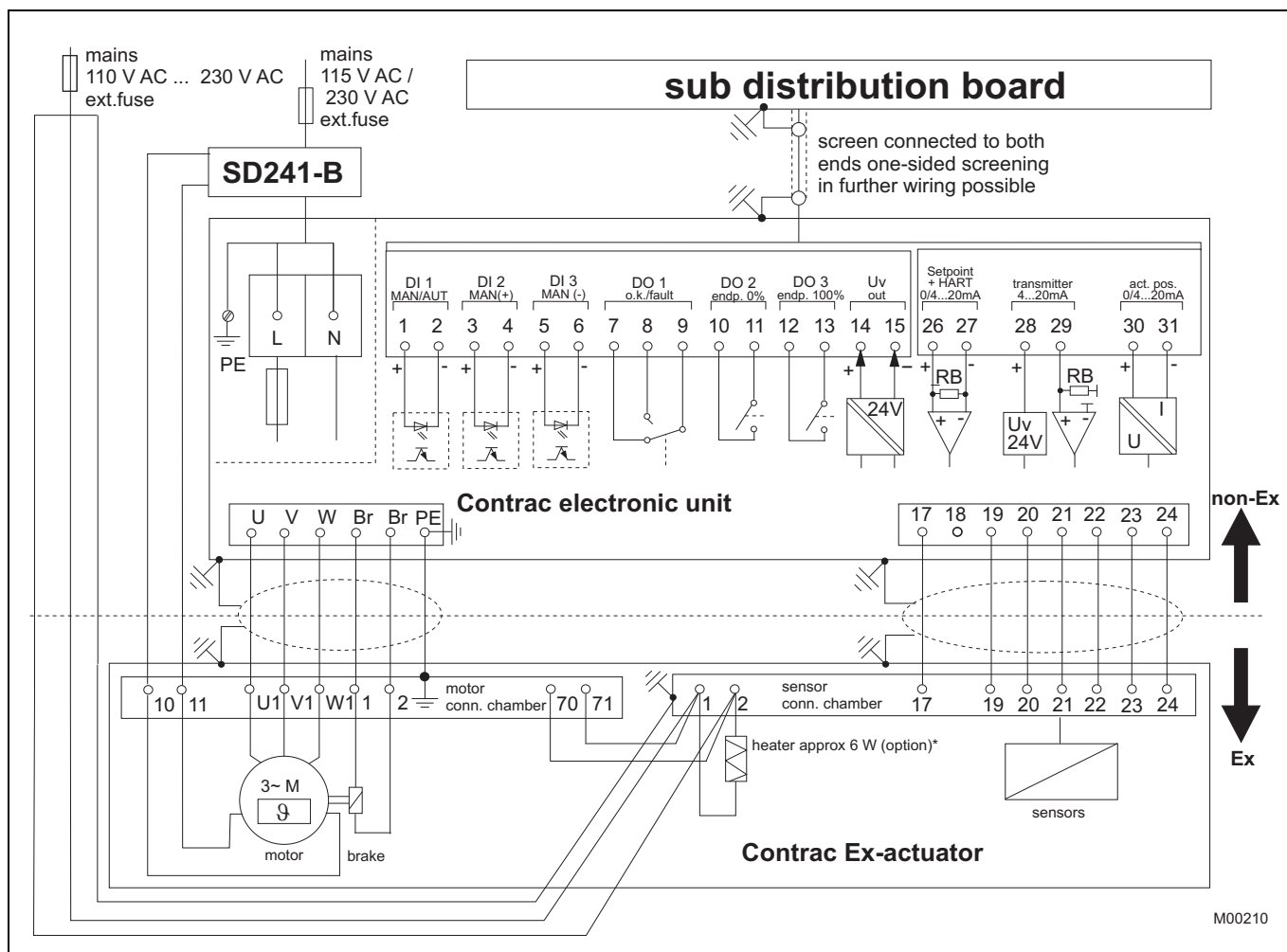

Fig. 9: Electrical connection: Ex actuator analog / digital



Important

*If you are using a separate heat supply, install 2 ... max. 6 A medium time-lag fuses (e.g., Neozed D01CE14) to protect the heater.

PROFIBUS DP (EBN861 only)

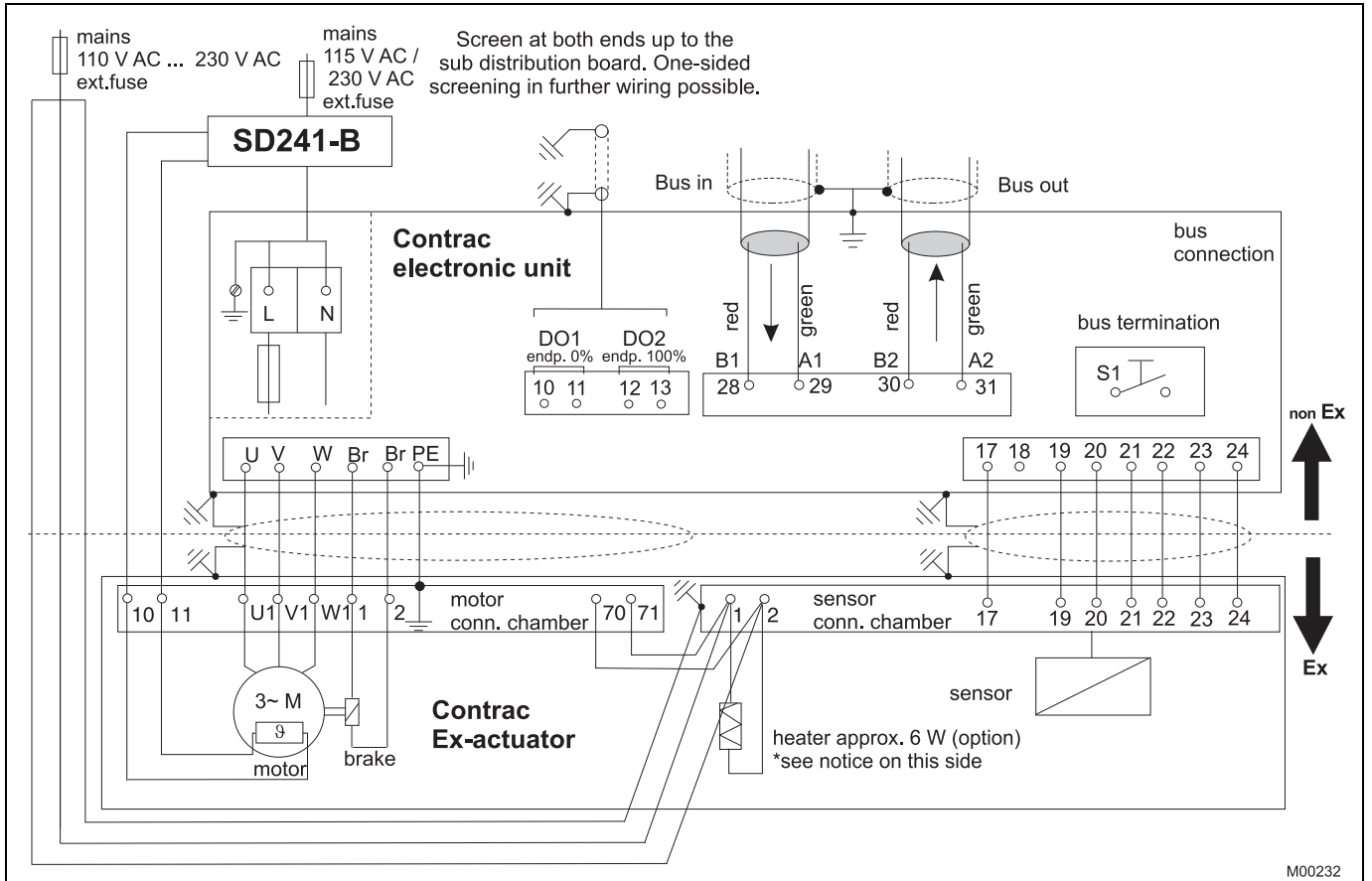

Fig. 10: Electrical connection: PROFIBUS DP option



Important

*If you are using a separate heat supply, install 2 ... max. 6 A medium time-lag fuses (e.g., Neozed D01CE14) to protect the heater.

6 Technical data

6.1 Part-turn actuators

Types:	RHDE250 ... 16000
Rated torque	250 ... 16000 Nm (185 ... 11800 lbf-ft)
Starting torque	1.2 x rated torque (transient break-away torque for starting from end positions 2x rated force)
Rated stroke time	10 ... 80 s (adjustable up to 900 s)
Operating angle	90° (adjustable 35 ... 140°)
Weight	61.5 ... 1030 kg (136 ... 2270 lb)
Thermal motor monitoring	With SD241-B motor temperature monitoring unit or similar certified tripping unit
Motor types	BD80... ... BD112...
Operating mode	S9; stallproof acc. to IEC 60034-1 / EN 60034-1
Protection class	IP 66
Explosion protection	Acc. to ATEX II 2 GD ck EEx de [ib] ib II B T4 or IP 6x T=130 °C ZELM 04 ATEX 0209 X Acc. to Rostechnadzor 2 Ex deib [ib] II B T 4 DIP A21 T _A 130 °C, IP 66
Ambient temperature	-25 ... 60 °C (-13 ... 140 °F) with MOBIL SHC 629 type oil -30 ... 40 °C (-22 ... 104 °F) with MOBIL SHC 626 type oil
Transport and storage temperature	-25 ... 70 °C (-15 ... 158 °F)
Installation position	IMB 3, IMB 6, IMB 7, IMV 6 acc. to IEC 60034-7 / EN 60034-7; preferably IMB 3
Coating	2-layer component epoxy (RAL 9005, black)
Power supply for motors and sensors	Via specifically configured power electronic unit only

6.2 Linear actuators

Types:	RSDE10 ... 50
Rated force	10 ... 50 kN (2200 ... 11000 lbf)
Starting force	1.2 x rated force (transient break-away torque for starting from end positions 2 x rated force)
Rated actuator travel	Max. 300 mm (12 inches) (adjustable)
Weight	57 ... 85 kg (126 ... 187 lb)
Thermal motor monitoring	With SD241-B motor temperature monitoring unit or similar certified tripping unit
Motor types	BD80... ... BD112...
Operating mode	S9; stallproof acc. to IEC 60034-7 / EN 60034-1
Protection class	IP 66
Explosion protection	Acc. to ATEX II 2 GD ck EEx de [ib] ib II B T4 or IP 6x T=130 °C ZELM 04 ATEX 0209 X Acc. to Rostechnadzor 2 Ex deib [ib] II B T 4 DIP A21 T _A 130 °C, IP 66
Ambient temperature	-20 ... 60 °C (-4 ... 140 °F) with MOBIL SHC 629 type oil
Transport and storage temperature	-20 ... 60 °C (-4 ... 140 °F)
Installation position	IMV 1, IMV 3, IMV 7, IMV 5 acc. to IEC 60034-7 / EN 60034-7; preferably IMV 1
Coating	2-layer component epoxy (RAL 9005, black)
Power supply for motors and sensors	Via specifically configured power electronic unit only

6.3 Power electronic unit for field installation

Types:	EBN853 / EBN861
Protection class	IP 66
Ambient temperature	-25 ... 55 °C (-15 ... 130 °F)
Transport and storage temperature	-30 ... 75 °C (-20 ... 167 °F)
Weight	EBN853: 11 kg (24 lbs) EBN861: 40 kg (88 lbs)
Supply voltage	115V AC (94 ... 127 V) or 230 V AC (190 ... 253 V); 47.5 ... 63 Hz; single phase
Max. cable length between actuator and electronic unit:	100 m (328 ft)

6.4 Power electronic unit for rack installation

Types:	EBS852 / EBS862
Protection class	IP 20
Rack inlet temperature	0 ... 45 °C (32 ... 110 °F)
Transport and storage temperature	-25 ... 70 °C (-15 ... 158 °F)
Weight	EBS852: 11 kg (24 lb) EBS862: 40 kg (88 lb)
Supply voltage	115V AC (94 ... 127 V) or 230 V AC (190 ... 253 V); 47.5 ... 63 Hz; single phase
Max. cable length between actuator and electronic unit:	Dependent upon cable gauge; up to 430 m (1380 ft)

6.5 Motor temperature monitoring unit

Types:	SD241-B
Protection class	IP 54
Operating temperature	-25 ... 60 °C (-13 ... 140 °F)
Transport and storage temperature	-25 ... 70 °C (-15 ... 158 °F)
Supply voltage	115V AC (94 ... 121 V) or 230 V AC (196 ... 253 V); 50 / 60 Hz

ABB has Sales & Customer Support
expertise in over 100 countries worldwide.

www.abb.com/instrumentation

The Company's policy is one of continuous product
improvement and the right is reserved to modify the
information contained herein without notice.

Printed in the Fed. Rep. of Germany (06.2008)

© ABB 2008

3KXE100002R2901



ABB Limited

Salterbeck Trading Estate
Workington, Cumbria
CA14 5DS

UK

Tel: +44 (0)1946 830 611

Fax: +44 (0)1946 832 661

ABB Inc.

125 E. County Line Road
Warminster, PA 18974
USA

Tel: +1 215 674 6000

Fax: +1 215 674 7183

ABB Automation Products GmbH

Schillerstr. 72
32425 Minden
Germany

Tel: +49 551 905-534

Fax: +49 551 905-555

CCC-support.deapr@de.abb.com