

TTF350

Field mounted Temperature Transmitter

Sensor adjustment
Redundancy 2 x Pt100 3-L
Sensor drift monitoring



HART, Dual-compartment Housing Technology, Pt100 (RTD), thermocouples

Input

- Resistance thermometers, thermocouples
- Resistance-type transmitter (0 ... 5000 Ω)
- Voltages, mV transmitter (-125 ... 1100 mV)

Input functionality

- 1 or 2 sensors (e.g., 2 x Pt100 3-L)
- Sensor backup/redundancy
- Sensor drift monitoring

Output

- 2-wire technique
- 4 ... 20 mA temperature linear, HART signal

Measurement error

- 0.1 K

Specific linearization

- Callendar-Van Dusen coefficients
- Table of variate pairs / 32 points

Fieldhousing

- Dual-compartment technology
- 3 cable glands (2 sensor inputs)
- Protection class IP 66 / 67, NEMA 4X, ENCL 4X

Continuous sensor and self-monitoring

- Supply voltage monitoring
- Wire break and corrosion monitoring (NE 89)
- Extended diagnostics (NE 107)

Device safety in accordance with NE 53, NE 79

Approvals for explosion protection

- Intrinsic Safety: ATEX EEx ia (Zone 0), FM, CSA
- Non-incendive: ATEX EEx n A
- Dust-ignition Proof: ATEX / Zone 20
- Flameproof Enclosures: ATEX / Zone 1, FM, CSA

Configuration

- Display with TTF350 configuration options
- FDT/DTM (e.g., SMART VISION DSV401)
- EDD

Contents

1	Technical data	3
1.1	Input.....	3
1.2	Output.....	3
1.3	Power supply (polarity safe).....	4
2	General information	4
2.1	Ambient conditions	4
2.2	Electromagnetic compatibility.....	4
2.3	Interference immunity.....	4
2.4	Measuring accuracy	5
2.5	Operating conditions	7
3	Mechanical design	8
4	Communication	9
5	Explosion-protection relevant information	10
5.1	TTF350-E1 .. H: (intrinsic safety) TTF350.....	10
5.2	TTF350-E2 .. H: (non-incendive) TTF350 ..	10
6	Approvals	11
7	LCD-display	12
7.1	Features of the LCD display.....	12
7.2	Configuration function of LCD display.....	12
7.3	LCD display HMI ignition-proof type B (Intrinsic Safety).....	12
8	Terminal connection diagrams	13
9	Dimensional drawings	15
9.1	Installation	16
10	Ordering information	17
10.1	Order form configuration	19

1 Technical data

1.1 Input

1.1.1 Resistance

RTD resistance thermometer

Pt100 in acc. with DIN IEC 60751, JIS, MIL, Ni in acc. with DIN 43760, Cu

Resistance measurement

0 ... 500 Ω

0 ... 5000 Ω

Sensor connections

2-, 3-, 4-wire circuit

Connecting cables

2-, 3-, 4-wire max. sensor line resistance (R_W) for each wire 50 Ω
in acc. with NE 89 (March 2003);

(3-wire balanced, 2-wire circuit compensation up to 100 Ω sensor
total line resistance)

Measurement current

< 300 μ A

Sensor short-circuit

< 5 Ω (for RTD)

Sensor wire break (temperature resistance measurement 2-, 3-, 4-wire)

Measuring range 0 ... 500 Ω > 0.6 ... 10 k Ω

Measuring range 0 ... 5 k Ω > 5.3 ... 10 k Ω

Corrosion detection in accordance with NAMUR NE 89

3-wire resistance reading > 50 Ω

4-wire resistance reading > 50 Ω

1.1.2 Thermocouples/Voltages

Types

B, E, J, K, L, N, R, S, T, U, C, D

Voltages

-125 mV ... 125 mV

-125 mV ... 1100 mV

Connecting cables

Max. sensor line resistance (R_W) for each line 1.5 k Ω , total 3 k Ω

Sensor wire break monitoring in accordance with Namur NE 89

pulsed with 1 μ A outside the measurement interval

Thermoelement measurement 5.3 ... 10 k Ω

Voltage measurement 5.3 ... 10 k Ω

Input resistance

> 10 M Ω

Internal reference junction

Pt100, DIN IEC 60751 Cl. B

(no jumpers necessary)

Customer specific curve, 32-tie points

Resistance measurement up to max. 5 k Ω

Voltages up to max. 1.1 V

Sensor matching

via Callendar van Dusen coefficients

via table of 32 sampling points

via single point (offset adjustment)

via two point adjustment

Input functionality

1 Sensor

2 Sensors:

mean measurement

Differential measurement: Zero point where $I_a = 4$ mA

Differential measurement: Zero point where $I_a = 12$ mA

Sensor redundancy

Sensor fault signaling

RTD sensor:

Short circuit and wire break

Linear resistance measurement:

Wire break

Thermocouple:

Wire break

Linear voltage measurement:

Wire break

1.2 Output

Transmission characteristics

temperature linear

resistance linear

voltage linear

Output signal

Configurable 4 ... 20 mA (standard)

Configurable 20 ... 4 mA

(NE43 dynamic range: 3,8 ... 20.5 mA)

Simulation mode

3,5 ... 23,6 mA

Induced current consumption

< 3,5 mA

Maximum output current

23,6 mA

Configurable error current signal

override 22 mA (20.0 ... 23.6 mA)

underdrive 3.6 mA (3.5 ... 4.0 mA)

Configurable analog alarm pulse if

maintenance required.

In redundancy mode when a sensor fails and/or in

drift mode if the maximum sensor drift value will exceeded.

(For details, refer to OI TTF350.)

Two configurable warning limits

HART-Signal/diagnostic bit information

Two configurable alarm limits

HART-Signal/diagnostic bit information

1.3 Power supply (polarity safe)

(2-wire technique; power lines = signal lines)

Supply voltage

Non ignition-proof application with or without LCD display:

$$U_s = 11 \dots 42 \text{ V DC}$$

Ignition-proof applications with or without LCD display:

$$U_s = 11 \dots 30 \text{ V DC}$$

Max. permissible residual ripple for supply voltage

Max. permissible ripple for supply voltage during communication in accordance with HART FSK "Physical Layer" specification, version 8.1 (08/1999) Section 8.1

Undervoltage detection

$$U_{\text{Terminal-Mu}} < 10 \text{ V results in } I_a = 3.6 \text{ mA}$$

Max. load

$$R_{\text{Load}} = (\text{supply voltage} - 11 \text{ V}) / 22 \text{ mA}$$

Max. load Ω depending on supply voltage (V DC)

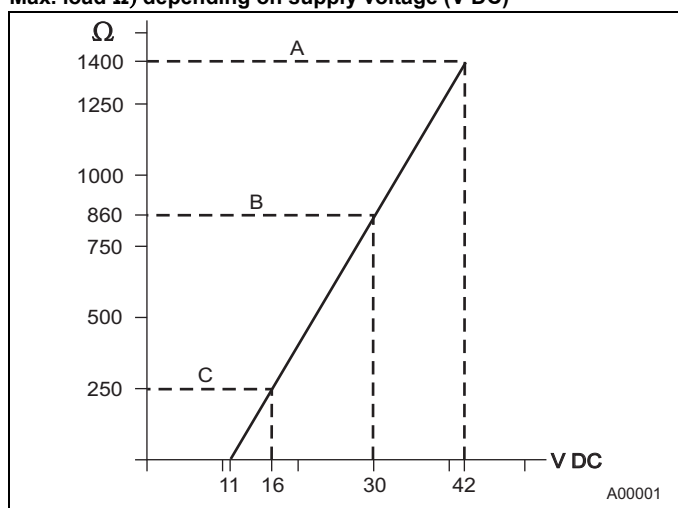

Fig. 1

- A TTF350, C HART communication - resistor
B TTF350 in EEx ia design

Max. power consumption

$$P = U_s \times 22 \text{ mA}$$

e.g., $U_s = 24 \text{ V} \rightarrow P_{\text{max}} = 0.528 \text{ W}$

2 General information

Galvanic isolation (input/output)	3.5 kV AC (approx. 2.5 kV DC) 60 s (insulation test voltage)
MTBF time	28 years at 60 °C ambient temperature
Input filter	50 / 60 Hz
Switch-on delay	< 10 s ($I_a \leq 3.6 \text{ mA}$ during starting cycle)
Warm-up time	5 min.
Ramp-up time t90	400 ... 1000 ms
Reading updated¹⁾	10/s with 1 sensor, 5/s with 2 sensors
Output filter	Digital filter 1st order: 0 ... 100 s

¹⁾ depending on sensor type and sensor circuit

2.1 Ambient conditions

Ambient temperature:

Standard: -40 ... 85 °C / -40 ... 185 °F

Optional: -50 ... 85 °C / -58 ... 185 °F

For use with LCD display HMI type B:

-20 ... 70 °C / -4 ... 158 °F

For ignition-proof design, see prototype test certificate PTB 05 ATEX 2079 X.

Transport / storage

temperature: -40 ... 85 °C / -40 ... 185 °F

Climate class:

Cx (-40 ... 85 °C / -40 ... 185 °F, 5 ... 95% relative humidity)
DIN EN 60654-1

Max. permissible humidity:

99% relative humidity IEC 60068-2-78

Vibration resistance*:

10 ... 2000 Hz at 5 g acc. to IEC 60068-2-6

Shock*:

gn = 30 in accordance with IEC 60068-2-27

Earthquake resistance:

Acc. to EN1473

Salt fog:

acc. to IEC 60068-2-11

Protection class:

IP66 and IP67; NEMA 4X, ENCL 4X

* applies to operation and transport

2.2 Electromagnetic compatibility

Emitted interference in accordance with IEC 61326 (2006) and Namur NE21 (02/2004)

2.3 Interference immunity

Interference immune in accordance with IEC 61326 (2002) and Namur NE21 (02/2004)

Pt100: Measuring range 0 ... 100 °C, span 100 K

Type of test	Testing accuracy	Influence
Burst to signal/data lines	2 kV	< 0.5%
Static discharge		
• Contact plate (indirect)	8 kV	no
• Supply terminals ¹⁾	6 kV	no
• Sensor terminals ¹⁾	4 kV	no
Radiated field		
80 MHz ... 2 GHz	10 V/m	< 0.5%
Coupling		
150 kHz ... 80 MHz	10 V	< 0.5%
Surge		
between the lines	0.5 kV	no malfunction
Line to earth	1 kV	no malfunction

¹⁾ Air discharge (at 1 mm distance)

2.4 Measuring accuracy

Includes linearity deviation, reproducibility/hysteresis at 23 °C ± 5 K and 20 V supply voltage

Information on measuring accuracy corresponds to 3 σ (Gaussian distribution)

Input element		Measuring range limits	Minimum span	Digital measuring accuracy (24-bit A/D converter)	D/A accuracy ¹⁾ (1 6-bit DA)
Standard	Sensor				
Resistance sensors/potentiometer					
DIN IEC 60 751	RTD Pt10 (a=0,003850)	-200 ... 850 °C / -328 ... 1562 °F	10 °C / 18 °F	± 0,80 °C / ± 1,44 °F	± 0,05 %
	RTD Pt50 (a=0,003850)	-200 ... 850 °C / -328 ... 1562 °F	10 °C / 18 °F	± 0,16 °C / ± 0,29 °F	± 0,05 %
	RTD Pt100 (a=0,003850) ²	-200 ... 850 °C / -328 ... 1562 °F	10 °C / 18 °F	± 0,08 °C / ± 0,14 °F	± 0,05 %
	RTD Pt200 (a=0,003850)	-200 ... 850 °C / -328 ... 1562 °F	10 °C / 18 °F	± 0,24 °C / ± 0,43 °F	± 0,05 %
	RTD Pt500 (a=0,003850)	-200 ... 850 °C / -328 ... 1562 °F	10 °C / 18 °F	± 0,16 °C / ± 0,29 °F	± 0,05 %
	RTD Pt1000 (a=0,003850)	-200 ... 850 °C / -328 ... 1562 °F	10 °C / 18 °F	± 0,08 °C / ± 0,14 °F	± 0,05 %
JIS C1604-81	RTD Pt10 (a=0,003916)	-200 ... 645 °C / -328 ... 1193 °F	10 °C / 18 °F	± 0,80 °C / ± 1,44 °F	± 0,05 %
	RTD Pt50 (a=0,003916)	-200 ... 645 °C / -328 ... 1193 °F	10 °C / 18 °F	± 0,16 °C / ± 0,29 °F	± 0,05 %
	RTD Pt100 (a=0,003916)	-200 ... 645 °C / -328 ... 1193 °F	10 °C / 18 °F	± 0,08 °C / ± 0,14 °F	± 0,05 %
MIL-T-24388	RTD Pt10 (a=0,003920)	-200 ... 850 °C / -328 ... 1562 °F	10 °C / 18 °F	± 0,80 °C / ± 1,44 °F	± 0,05 %
	RTD Pt50 (a=0,003920)	-200 ... 850 °C / -328 ... 1562 °F	10 °C / 18 °F	± 0,16 °C / ± 0,29 °F	± 0,05 %
	RTD Pt100 (a=0,003920)	-200 ... 850 °C / -328 ... 1562 °F	10 °C / 18 °F	± 0,08 °C / ± 0,14 °F	± 0,05 %
	RTD Pt200 (a=0,003920)	-200 ... 850 °C / -328 ... 1562 °F	10 °C / 18 °F	± 0,24 °C / ± 0,43 °F	± 0,05 %
	RTD Pt1000 (a=0,003920)	-200 ... 850 °C / -328 ... 1562 °F	10 °C / 18 °F	± 0,08 °C / ± 0,14 °F	± 0,05 %
DIN 43760	RTD Ni50 (a=0,006180)	-60 ... 250 °C / -76 ... 482 °F	10 °C / 18 °F	± 0,16 °C / ± 0,29 °F	± 0,05 %
	RTD Ni100 (a=0,006180)	-60 ... 250 °C / -76 ... 482 °F	10 °C / 18 °F	± 0,08 °C / ± 0,14 °F	± 0,05 %
	RTD Ni120 (a=0,006180)	-60 ... 250 °C / -76 ... 482 °F	10 °C / 18 °F	± 0,08 °C / ± 0,14 °F	± 0,05 %
	RTD Ni1000 (a=0,006180)	-60 ... 250 °C / -76 ... 482 °F	10 °C / 18 °F	± 0,08 °C / ± 0,14 °F	± 0,05 %
	RTD Cu10 (a=0,004270)	-50 ... 200 °C / -58 ... 392 °F	10 °C / 18 °F	± 0,80 °C / ± 1,44 °F	± 0,05 %
	RTD Cu100 (a=0,004270)	-50 ... 200 °C / -58 ... 392 °F	10 °C / 18 °F	± 0,08 °C / ± 0,14 °F	± 0,05 %
	Resistance measurement	0 ... 500 Ω	4 Ω	± 32 mΩ	± 0,05 %
	Resistance measurement	0 ... 5000 Ω	40 Ω	± 320 mΩ	± 0,05 %
Thermocouples³⁾/voltages					
IEC 584	Type K (Ni10Cr-Ni5)	-270 ... 1372 °C / -454 ... 2502 °F	50 °C / 90 °F	± 0,35 °C / ± 0,63 °F	± 0,05 %
	Type J (Fe-Cu45Ni)	-210 ... 1200 °C / -346 ... 2192 °F	50 °C / 90 °F	± 0,35 °C / ± 0,63 °F	± 0,05 %
	Type N (Ni14CrSi-NiSi)	-270 ... 1300 °C / -454 ... 2372 °F	50 °C / 90 °F	± 0,35 °C / ± 0,63 °F	± 0,05 %
	Type T (Cu-Cu45Ni)	-270 ... 400 °C / -454 ... 752 °F	50 °C / 90 °F	± 0,35 °C / ± 0,63 °F	± 0,05 %
	Type E (Ni10Cr-Cu45Ni)	-270 ... 1000 °C / -454 ... 1832 °F	50 °C / 90 °F	± 0,35 °C / ± 0,63 °F	± 0,05 %
	Type R (Pt13Rh-Pt)	-50 ... 1768 °C / -58 ... 3215 °F	100 °C / 180 °F	± 0,95 °C / ± 1,71 °F	± 0,05 %
	Type S (Pt10Rh-Pt)	-50 ... 1768 °C / -58 ... 3215 °F	100 °C / 180 °F	± 0,95 °C / ± 1,71 °F	± 0,05 %
	Type B (Pt30Rh-Pt6Rh)	-0 ... 1820 °C / +32 ... 3308 °F	100 °C / 180 °F	± 0,95 °C / ± 1,71 °F	± 0,05 %
DIN 43710	Type L (Fe-CuNi)	-200 ... 900 °C / -328 ... 1652 °F	50 °C / 90 °F	± 0,35 °C / ± 0,63 °F	± 0,05 %
	Type U (Cu-CuNi)	-200 ... 600 °C / -328 ... 1112 °F	50 °C / 90 °F	± 0,35 °C / ± 0,63 °F	± 0,05 %
ASTM E 988	Type C	-0 ... 2315 °C / +32 ... 4200 °F	100 °C / 180 °F	± 1,35 °C / ± 2,43 °F	± 0,05 %
	Type D	-0 ... 2315 °C / +32 ... 4200 °F	100 °C / 180 °F	± 1,35 °C / ± 2,43 °F	± 0,05 %
	Voltage measurement	-125 mV ... 125 mV	2 mV	± 12 μV	± 0,05 %
	Voltage measurement	-125 mV ... 1100 mV	20 mV	± 120 μV	± 0,05 %

¹⁾ percentages refer to the configured measuring span

²⁾ Standard model

³⁾ include the internal reference junction error for digital accuracy: Pt100, DIN IEC 60751 Cl. B

⁴⁾ without reference junction error

Total accuracy = digital measuring accuracy [°C] + (D/A measuring accuracy [%] x | conf. measuring span [°C] | /100%)

(refer to the block diagram on next page)

Example 1:

Pt100 (IEC 60751), conf. measuring range 0 ... 100 °C, conf. measuring span = measurement end – measurement start = 100 °C

Digital measuring accuracy: ± 0,08 °C

D/A measuring accuracy ± 0,05% x (100 °C/100%) = ± 0,05 °C

Total accuracy: Digital accuracy + D/A accuracy; ± 0,08 °C + (± 0,05 °C) = ± 0,13 °C

Example 2:

Thermocouple type K, conf. measuring range 0 ... 1000 °C, conf. measuring span = measurement end – measurement start = 1000 °C

Digital measuring accuracy: ± 0,35 °C

D/A measuring accuracy ± 0,05% x (1000 °C/100%) = ± 0,50 °C

Total accuracy⁴⁾: Digital accuracy + D/A accuracy; ± 0,35 °C + (± 0,50 °C) = ± 0,85 °C

Long-term drift

± 0.05 °C or ± 0.05%¹⁾ per year, the larger value applies.

2.4.1 Block diagram

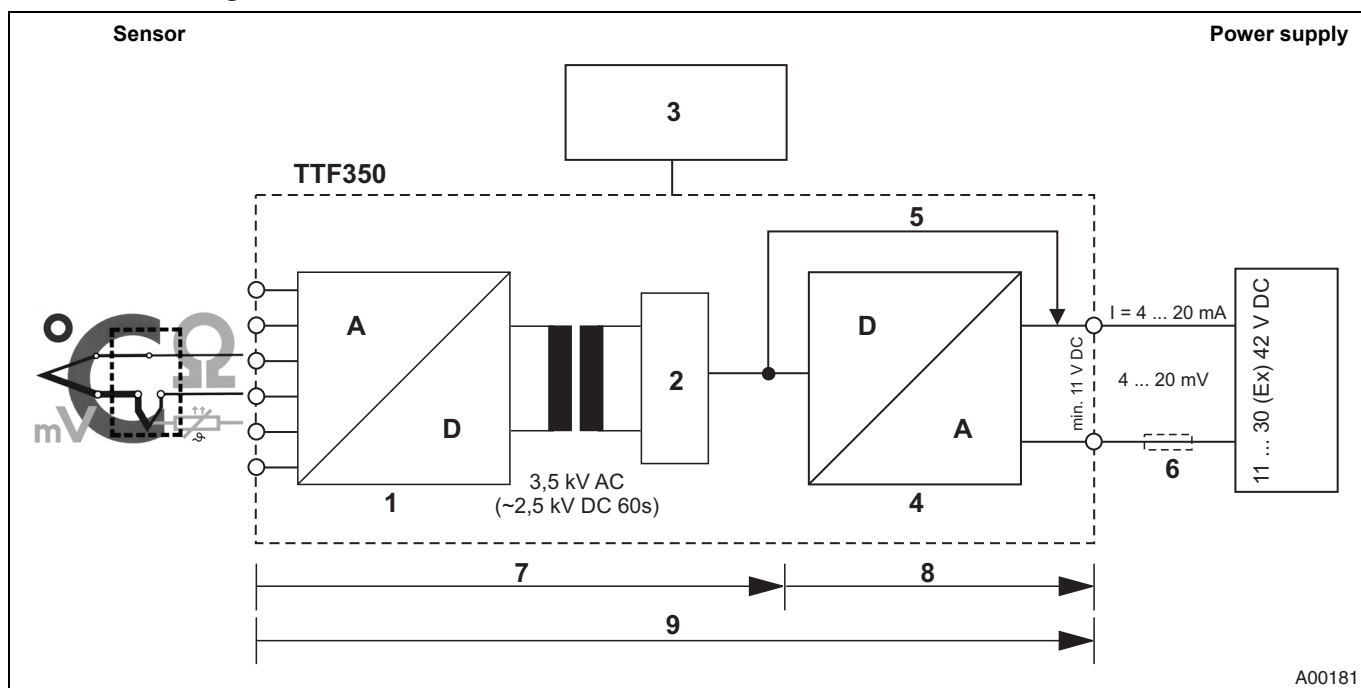

A00181

Fig. 2

- | | | | |
|---|--|---|--|
| 1 | 24-bit A/D converter | 6 | Load (observe voltage drop, refer to the section "Terminal connection diagrams") |
| 2 | Microcontroller | 7 | Digital measuring accuracy |
| 3 | LCD display with TTF300/TTF350 configuration options | 8 | D/A measuring accuracy |
| 4 | 16-bit D/A converter | 9 | Overall measuring accuracy |
| 5 | HART signal | | |

2.5 Operating conditions

The percentages refer to the configured measuring span.

Supply voltage influence/load influence: within the specified limits for the voltage/load the total influence is less than 0.001% per volt

Common-mode interference no influence up to 100 V Veff (50 Hz) or 50 VDC

Ambient temperature influence: based on 23 °C / 73.4 °F (ambient temperature range: -40 ... 85 °C / -40 °F ... 185 °F)

Sensor	Ambient temperature influence For 1 °C / 1.8 °F dev. to 23 °C / 73,4 °F for digital readings	Ambient temperature influence ¹⁾ For 1 °C / 1.8 °F dev. to 23 °C / 73,4 °F for D/A converter
2-, 3-, 4-wire circuit		
RTD Pt10 IEC, JIS, MIL	± 0.04 °C / ± 0.072 °F	± 0.003 %
RTD Pt50 IEC, JIS, MIL	± 0.008 °C / ± 0.014 °F	± 0.003 %
RTD Pt100 IEC, JIS, MIL	± 0.004 °C / ± 0.007 °F	± 0.003 %
RTD Pt200 IEC, MIL	± 0.02 °C / ± 0.036 °F	± 0.003 %
RTD Pt1000 IEC, MIL	± 0.004 °C / ± 0.007 °F	± 0.003 %
RTD Ni50 DIN 43760	± 0.008 °C / ± 0.014 °F	± 0.003 %
RTD Ni100 DIN 43760	± 0.004 °C / ± 0.007 °F	± 0.003 %
RTD Ni120 DIN 43760	± 0.003 °C / ± 0.005 °F	± 0.003 %
RTD Ni1000 DIN 43760	± 0.004 °C / ± 0.007 °F	± 0.003 %
Resistance measurement 0 ... 500 Ω	± 0.002 Ω	± 0.003 %
Resistance measurement 0 ... 5000 Ω	± 0.02 Ω	± 0.003 %
Thermoelement for all defined types	± [(0.001% x (ME[mV] / MS[mV]) + (100% x (0.009 °C / MS [°C])) ¹⁾	± 0.003 %
Voltage measurement -125 ... 125 mV	± 1.5 μV	± 0.003 %
-125 ... 1100 mV	± 15 μV	± 0.003 %

¹⁾ percentages refer to the configured measuring span
ME - Measuring end, MS - Measuring span

Example 1

Pt100 configured measuring range 0 ... 100 °C, (measuring span 100 °C), ambient temperature 33 °C

Dev. from standard temperature: 33 ... 23 °C (reference) = 10 °C

Affect of ambient temperature on digital measurement: 10 °C x ± 0.004 °C / °C = ± 0.04 °C

Affect of ambient temperature on D/A converter: 10 °C x (± 0.003 % / °C) x (100 °C / 100 %) = ± 0.03 °C

Example 2

TC type K, conf. measuring range 0 ... 1000 °C, (measuring span 1000 °C), ambient temperature 33 °C

Measuring start 0 °C corresponds to 0.0 mV; measuring end = 1000 °C corresponds to 41.6 mV; measuring span = 1000 °C or 41.6 mV

Dev. from standard temperature: 33 ... 23 °C (reference) = 10 °C

Affect of ambient temperature on digital measurement: 10 °C x [(± 0.001% x 41.6 mV / 41.6 mV) + (100% x ± 0.009 °C / 1000°C)] x (1000°C / 100%) / °C = ± 0.19 °C

Affect of ambient temperature on D/A converter: 10 °C x [± 0.003 % x 1000 °C / 100 %] / °C = ± 0.3 °C

Worst case total error analysis

Max. possible total error = SQR [(digital accuracy)² + (D/A accuracy) + (digital value temp. influence) + (D/A temp. influence)]

Example 1: Pt100, 0 ... 100°C at 33 °C ambient temperature = $\sqrt{(0.08^{\circ}\text{C})^2 + (0.05^{\circ}\text{C})^2 + (0.04^{\circ}\text{C})^2 + (0.03^{\circ}\text{C})^2} = 0.10^{\circ}\text{C}$

Example 2: Thermoelement type K, 0 ... 1000 °C at 33 °C ambient temperature = $\sqrt{(0.35^{\circ}\text{C})^2 + (0.50^{\circ}\text{C})^2 + (0.19^{\circ}\text{C})^2 + (0.3^{\circ}\text{C})^2} = 0.70^{\circ}\text{C}$
(without reference junction error)

3 Mechanical design

Dimensions: Refer to dimensioned drawings
Weight: 1,40 kg

- Housing: Aluminum die cast, chromized inside/outside, 70 µm epoxy-coated (aluminum, magnesium content < 6%, copper-free < 0.5%)
- Color: gray RAL9002
- Types of protection: IP66 and IP67; NEMA 4X, ENCL 4X

Installation conditions:

- Installation position: No limitations

Electrical connection:

- Thread (selectable) 3 x M20 x 1.5 / 3 x 1/2" NPT / 3 x 3/4" NPT (via reducing piece)
- with cable gland 3 x M20 x 1.5:
Polyamide/gray:
Non ignition-proof design, non-incendive max. cable outer diameter 5 ... 9 mm, temp. range acc. to data for cable gland

Polyamide/blue:
EEx ia design, intrinsic safety, max. cable outer diameter 5 ... 9 mm, temp. range acc. to data for cable gland

Metal cable gland:

dust-ignition proof, flame-proof, explosion-proof
max. cable outer diameter 6 ... 7.5 mm, temp. range -20 ... 90 °C / -4 ... 194 °F

- Ground screw external 6 mm² M5 internal 2.5 mm² terminal
- Terminals for lines up to max. 2.5 mm² and hand-held terminal interface

Lightning protection:

- **model NGV220-NO**
Non ignition-proof lightning protection for M20 x 1.5 cable gland (see data sheet 10/63-6.15)
- **model NGV220-Ex**
Intrinsically safe lightning protection for M20 x 1.5 cable gland (see data sheet 10/63-6.15)

4 Communication

HART protocol version 5

The system is registered with the HART Communication Foundation.

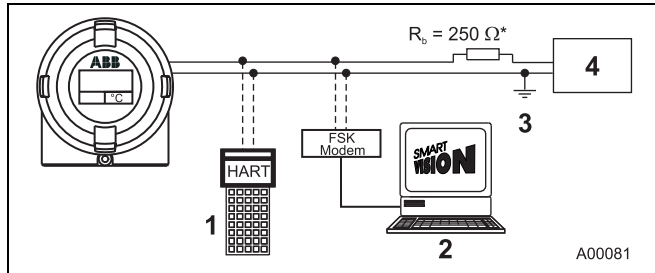

Fig. 3

* if necessary

- | | | | |
|---|---|---|-------------------------------------|
| 1 | DHH691 (691HT), STT04,
HC275, FC375 | 3 | Ground connection
(optional) |
| 2 | FDT/DTM technology or
EDD technology | 4 | Power supply (process
interface) |

Operating modes

- Point-to-point communication mode: standard (general address 0)
- Multidrop mode (addressing 1 ... 15)
- Burst mode

Configuration options and tools

Driver-independent:

- HMI indicator type B with configuration function

Driver-dependent:

Device management/asset management tools

- FDT/DTM technology
e.g., DSV401 (SMART VISION) via TTX300-DTM driver
- EDD technology
e.g., Simatic via TTX300 EDD driver

Configuration parameters

Measurement type

- Sensor type, connection type
- Fault signaling
- Measuring range
- General information, e.g., TAG number
- Damping
- Warning and alarm limits
- Signal simulation of output
- See "Order form configuration"

Write Protection

- Software write protection via HART/indicator
- Hardware write protection via DIP switch

Diagnostic information (NE107)

Standard

- Sensor error (wire break or short circuit)
- Device error
- Over/under alarm limits
- Over/under measuring range
- Simulation activated

Extended mode

- Redundancy/sensor backup active (in case sensor fails) with configurable analog alarm pulse signaling (see the operating instructions)
- Drift monitoring with configurable alarm pulse signaling (see the operating instructions)
- Sensor/sensor line corrosion
- Supply voltage to low
- Drag indicator for sensor 1, sensor 2 and ambient temperature
- Ambient temperature exceeding ($> 85\text{ }^{\circ}\text{C}$)
- Ambient temperature to low ($< 40\text{ }^{\circ}\text{C}$)
- Operating hours counter

5 Explosion-protection relevant information

5.1 TTF350-E1 .. H: (intrinsic safety) TTF350

Approved for use in zone 0.

Designation:

- II 1G EEx ia IIC T6 (Zone 0)
- II 2 (1) G EEx [ia] ib IIC T6 (zone 1 [0])
- II 2 G (1D) Ex [iaD] ib IIC T6 (zone 1 [20])

i Important

The Ex or ignition-proof designation is provided on the name plate.

EC prototype test certificate: Refer to PTB 05 ATEX2017 X.

Temperature table

Temperature class	Permissible ambient temperature range	
	Device category 1 use	Device category 2 use
T6	-50 ... 44 °C	-50 ... 56 °C
T5	-50 ... 56 °C	-50 ... 71 °C
T4	-50 ... 84 °C	-50 ... 85 °C

Safety-relevant data

Intrinsically safe EEx ia IIC explosion protection

	Supply circuit	Measurement current circuit / passive transducer (RTD)	Measurement current circuit / active transducer (RTD)	Display interface
Max. voltage	$U_i = 30 \text{ V}$	$U_o = 6,5 \text{ V}$	$U_o = 1,2 \text{ V}$	$U_o = 6,2 \text{ V}$
Short-circuit current	$I_i = 130 \text{ mA}$	$I_o = 25 \text{ mA}$	$I_o = 50 \text{ mA}$	$I_o = 65,2 \text{ mA}$
Max. power	$P_i = 0,8 \text{ W}$	$P_o = 38 \text{ mW}$	$P_o = 60 \text{ mW}$	$P_o = 101 \text{ mW}$
Internal inductance	$L_i = 0,5 \text{ mH}$	$L_i = 0 \text{ mH}$	$L_i = 0 \text{ mH}$	$L_i = 0 \text{ mH}$
Internal capacitance	$C_i = 5 \text{ nF}$	$C_i = 49 \text{ nF}$	$C_i = 49 \text{ nF}$	$C_i = 0 \text{ nF}$
Maximum permissible external inductance		$L_o = 5 \text{ mH}$	$L_o = 5 \text{ mH}$	$L_o = 5 \text{ mH}$
Maximum permissible external capacitance		$C_o = 1,55 \text{ }\mu\text{F}$	$C_o = 1,05 \text{ }\mu\text{F}$	$C_o = 1,4 \text{ }\mu\text{F}$

5.2 TTF350-E2 .. H: (non-incendive) TTF350 ..

Approved for use in zone 2/22.

Designation:

- II 3 G EEx n A II T6
- II 3 D IP 65 T 135 °C

i Important

The Ex or ignition-proof designation is provided on the name plate.

ABB statement of conformity in accordance with ATEX directive.

Temperature table

Temperature class	Permissible ambient temperature range
T6	-50 °C ... 56°C
T5	-50 °C ... 71°C
T4	-50 °C ... 85°C

FM and CSA

Intrinsic Safety

FM	Class I, Div. 1 + 2, Groups A, B, C, D T6 Class II, Groups E, F, G; Class III Class I, Zone 0, AEx ia IIC T6 Product variant: -L4 .. H Control-Drawing: -L4 .. H
CSA	Class I, Div. 1 + 2, Groups A, B, C, D Class II, Groups E, F, G; Class III Product variant: -R4 .. H Control-Drawing: -R4 .. H

Non-Incendive

FM	Class I, Div. 2, Groups A, B, C, D (Class II, Groups E, F, G; Class III Product variant: -L5 .. H Control-Drawing: -L5 .. H (2 pages)
CSA	Class I, Div. 2, Groups A,B,C,D (Class II, Groups E, F, G; Class III Product variant: -R5 .. H Control-Drawing: -R5 .. H (2 pages)

Dust-explosion protection

-D1 ... : Dust-explosion protection

Dust / Zone 20:

Designation: "Ex mark" II 1 D IP 65 T 135 °C
EC prototype test certificate BVS06 ATEX E029

-D2 .. H: Dust-explosion protection + Intrinsic safety

Dust / Zone 20 + Gas / Zone 0:

Designation: "Ex mark" II 1 D IP 65 135 °C
"Ex mark" II 1G EEx ia IIC T6

EC prototype test certificate BVS06 ATEX E029
EC prototype test certificate PTB 05 ATEX 2017 X
EC prototype test certificate ZELM 07 ATEX 0331 U

Flameproof (Enclosure)

-E3...: flameproof (enclosure)

Zone 1:

Designation: "Ex mark" II 2G EEx d IIC T6
EC prototype test certificate ATEX

-E4 .. H: flameproof (enclosure) + intrinsic safety

Zone 1:

Designation: "Ex mark" II 2G EEx d IIC T6
"Ex mark" II 1G EEx ia IIC T6

EC prototype test certificate ATEX
EC prototype test certificate PTB 05 ATEX 2017 X
EC prototype test certificate ZELM 07 ATEX 0331 U

Explosionproof, Non-Incendive, Dust-Ignitionproof

-L3 ... FM Explosionproof, Non-Incendive, Dust-Ignitionproof

XP,NI, DIP Class I, II, III, Div. 1 + 2, Groups A-G, factory sealed
Control-Drawing: -L3

-R3 ... CSA Explosionproof, Non-Incendive, Dust-Ignitionproof

XP,NI, DIP Class I, II, III, Div. 1 + 2, Groups A-G, factory sealed
Control-Drawing: -R3

6 Approvals

CE mark

The TTF350 including type B LCD display / configuration software meets all requirements for the CE mark in accordance with IEC 61326 (2002).

Namur

The TTF350 including type B LCD display / configuration software complies with NAMUR NE 21 (02/2004).

Ignition protection

The TTF350 meets requirements for ATEX, FM and CSA. For additional information, refer to the section "Explosion-protection relevant information".

SIL: Functional safety (optional)

acc. to IEC 61508.

Device with certificate of conformity for use in safety-relevant applications, including SIL Level 2. For additional information, refer to the SIL safety manual for the TTH300 / TTF300 / TTF350.

7 LCD-display

Dual function: LCD display with TTF350 configuration options

7.1 Features of the LCD display

- Transmitter-controlled graphic (alphanumeric) LCD display
 - Character height, mode-dependent
 - Sign, 4 digits, 2 decimal places
- Bar graph display
- Plug in to 4 positions each 90° apart
- Display options:
 - Sensor 1 process data
 - Sensor 2 process data
 - Sensor 1 electrical (Ω / mV)
 - Sensor 2 electrical (Ω / mV)
 - Electronics/ambient temperature
 - Output/current
 - Output %
- Display diagnostic information related to transmitter and sensor status

7.1.1 Technical data of LCD display

Temperature range: -20 ... 70 °C
(-50 ... -20 °C or 70 ... 85 °C no function)

Humidity: 0 ... 99% relativ humidity IEC 60068-2-78

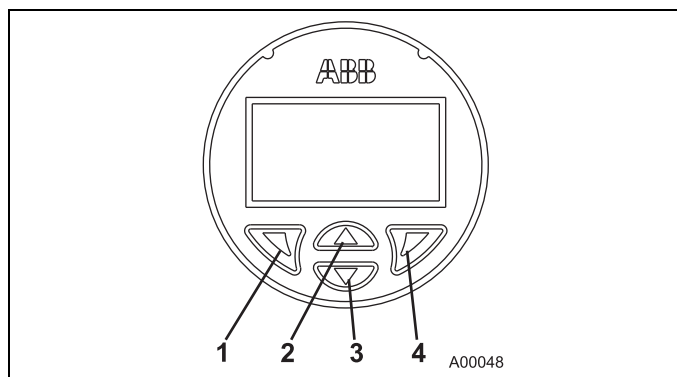

Fig. 4

- | | |
|---------------|------------------|
| 1 Exit/Cancel | 3 Scroll forward |
| 2 Scroll back | 4 Select |

7.2

Configuration function of LCD display

- Configurable TTF350 transmitter parameters per display: All parameters (sensor/type circuit, measuring range, leakage current signal, etc.)
except: table-based sensor and freestyle characteristics, Callendar van Dusen coefficients, warning and alarm limits, drift parameters, NE107 "Maintenance required" alarm pulse signal
- Software write protection for TTF350 configuration

7.3 LCD display HMI ignition-proof type B (Intrinsic Safety)

Approved for use in zone 0.

Designation:

- II 1G EEx ia IIC T6



Important

The Ex or ignition-proof designation is provided on the name plate.

EC prototype test certificate: ZELM 07 ATEX 0331 U

Temperature table

Temperature class	Permissible ambient temperature range	
	Device category 1 use	Device category 2 use
T6	-40 ... 40 °C	-40 ... 40 °C
T5	-40 ... 55 °C	-40 ... 55 °C
T4	-40 ... 85 °C	-40 ... 85 °C

For the ambient temperature range from -50 ... -20 °C, additional mechanical protection is required.

Safety-relevant data

Intrinsically safe EEx ia IIC explosion protection

	Supply circuit
Max. voltage	$U_i = 9 \text{ V}$
Short-circuit current	$I_i = 65,2 \text{ mA}$
Max. power	$P_i = 101 \text{ mW}$
Internal inductance	$L_i = 0 \text{ mH}$
Internal capacitance	$C_i = 342 \text{ nF}$

8 Terminal connection diagrams

RTD resistance sensors

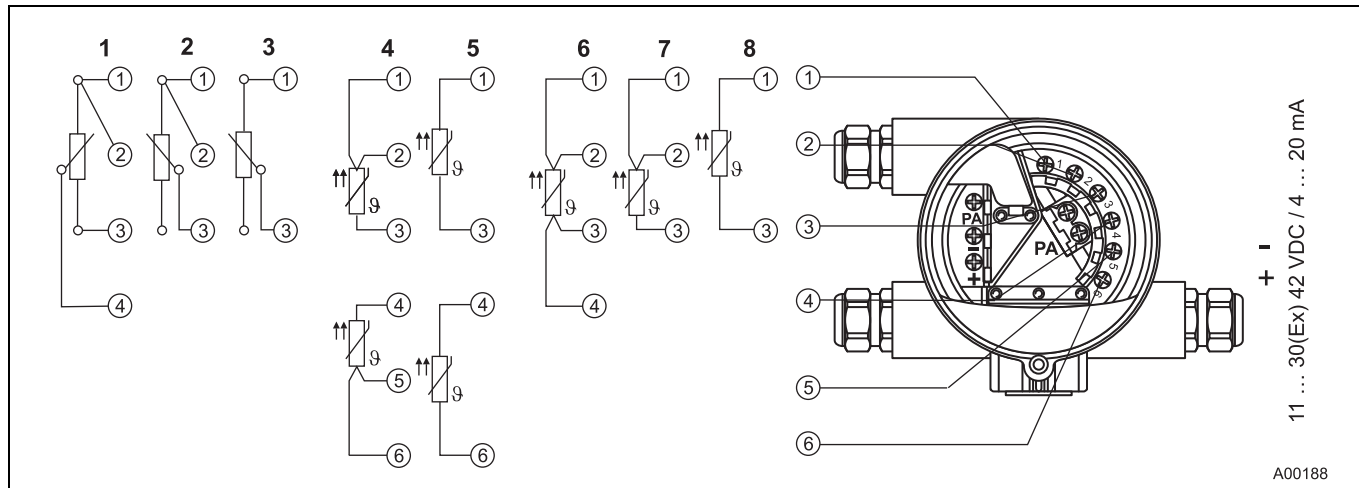

Fig. 5

Potentiometer: 0 ... 500 Ω or 0 ... 5000 Ω

- 1 Potentiometer, 4-wire circuit
- 2 Potentiometer, 3-wire circuit
- 3 Potentiometer, 2-wire circuit

- 4 2 x RTD, 3-wire circuit (sensor backup/redundancy, sensor drift monitoring, average value or differential temperature measurement)
- 5 2 x RTD, 2-wire circuit (sensor backup/redundancy, sensor drift monitoring, average value or differential temperature measurement)

- 6 RTD, 4-wire circuit
- 7 RTD, 3-wire circuit
- 8 RTD, 2-wire circuit

Thermocouples/Voltages

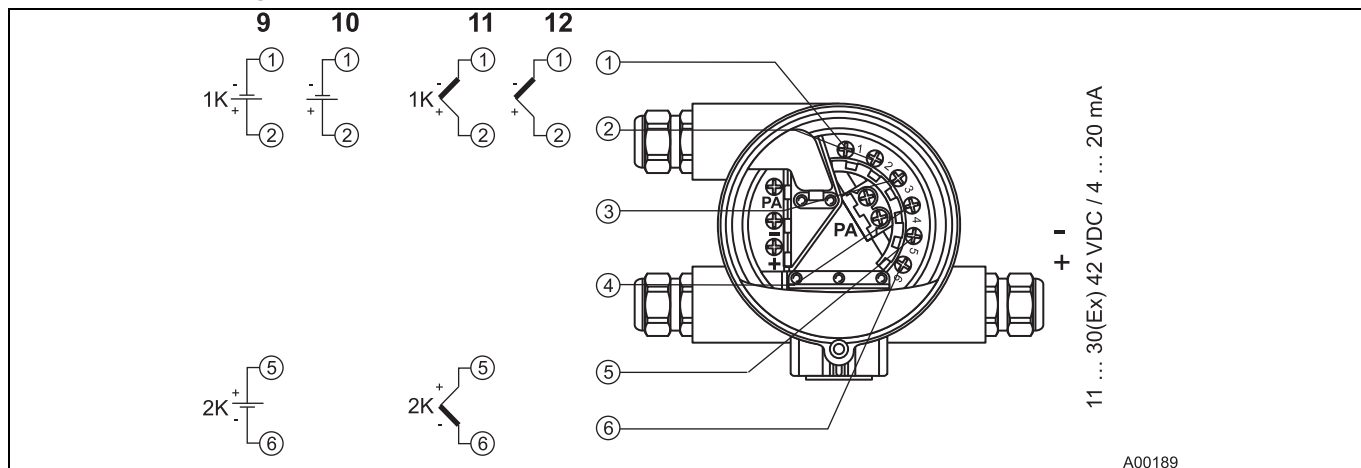

Fig. 6

- 9 2 x voltage measurement (sensor backup/redundancy, sensor drift monitoring, average value or differential temperature measurement)
- 10 Voltage measurement
- 11 2 x thermocouple (sensor backup/redundancy, sensor drift monitoring, average value or differential temperature measurement)
- 12 Thermocouple

RTD/thermocouples configuration

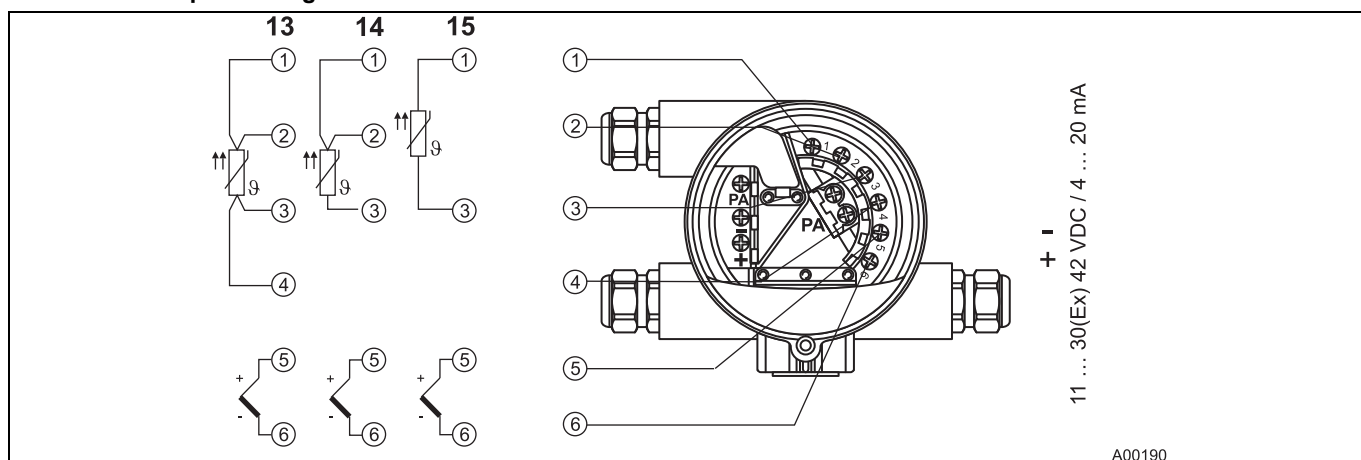

Fig. 7

- 13 1 x RTD, 4-wire circuit and thermocouple (sensor backup/redundancy, sensor drift monitoring, average value or differential temperature measurement)
- 14 1 x RTD, 3-wire circuit and thermocouple (sensor backup/redundancy, sensor drift monitoring, average value or differential temperature measurement)
- 15 1 x RTD, 2-wire circuit and thermocouple (sensor backup/redundancy, sensor drift monitoring, average value or differential temperature measurement)

9 Dimensional drawings

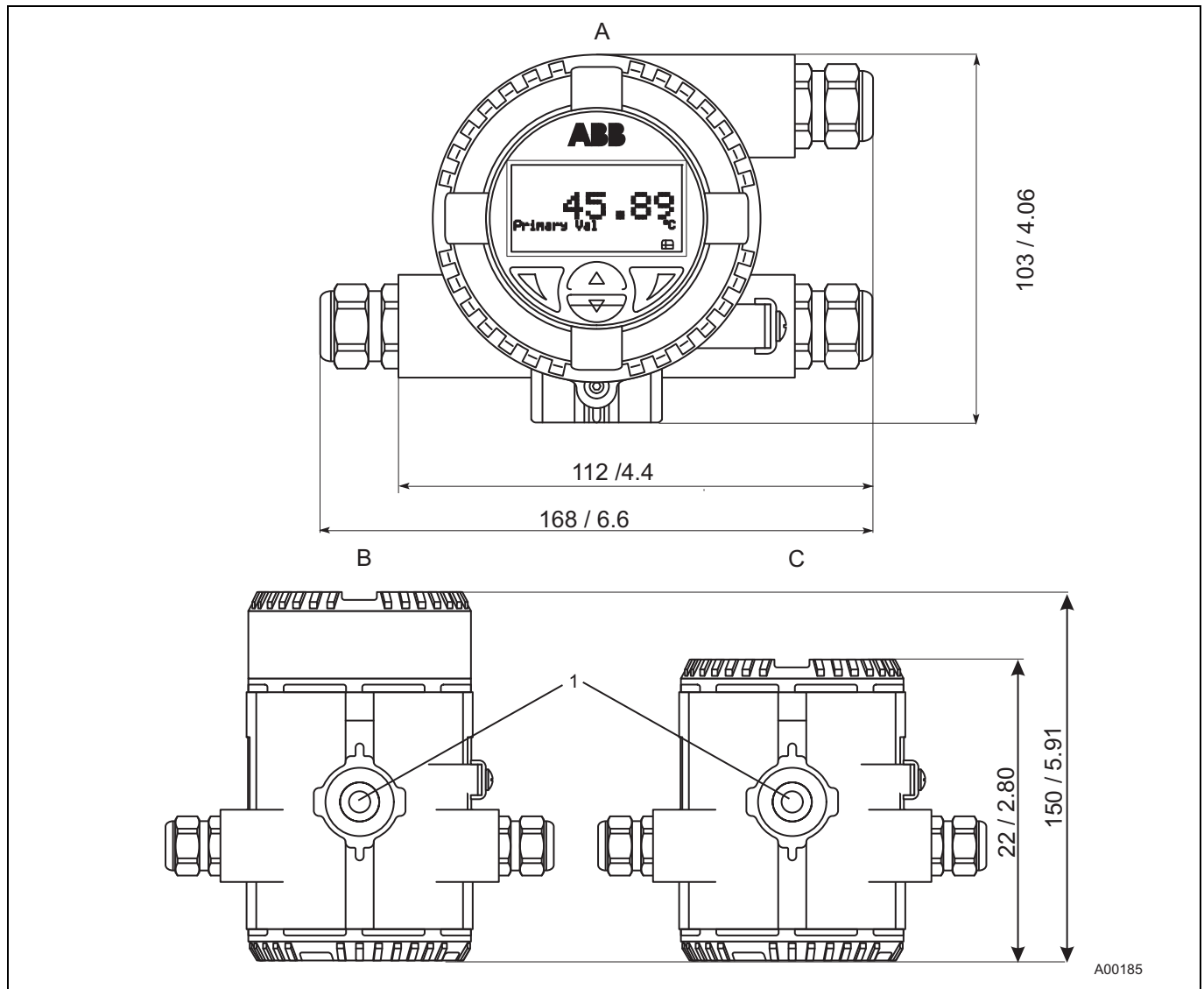

Fig. 8: Housing and mounting type with dimensions in mm/inches

- A Housing, display view (display installation option 4 x 90°)
 - without cable gland (threads M20 x 1.5 or NPT 1/2")
 - with cable gland (M20 x 1.5)
 - B Housing, bottom view with display option (fastening screw thread M8 (depth 10 mm))
 - C Housing, bottom view without display option (fastening screw thread M8 (depth 10 mm))
- 1 Housing (fastening screw thread M8 (depth 10 mm))

9.1 Installation

9.1.1 Wall installation

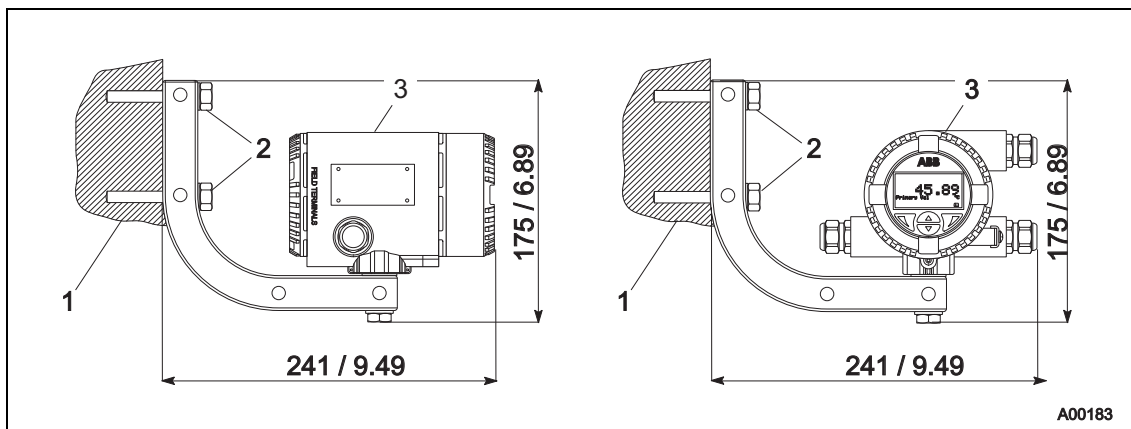

Fig. 9: Dimensions in mm/inch

1 Wall

3 Transmitter TTF350

2 Wall mount

9.1.2 Pipe installation

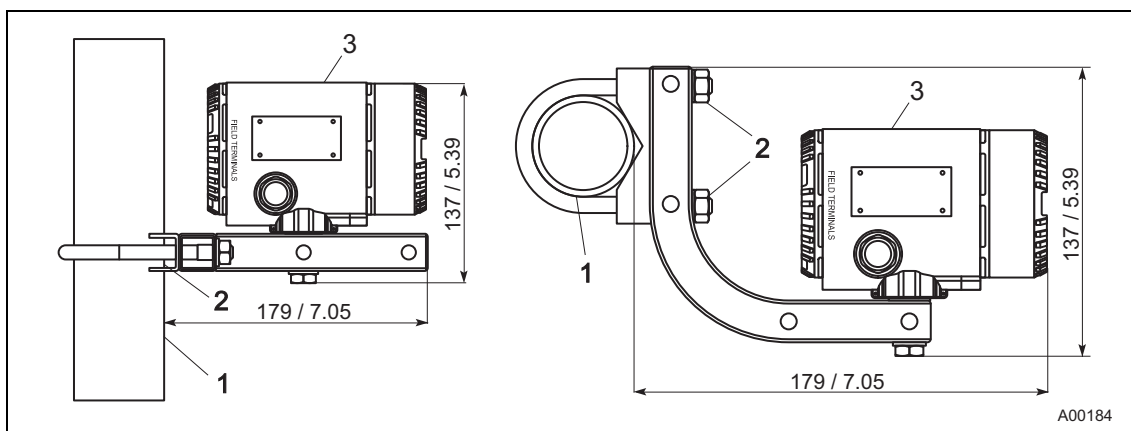

Fig. 10: Dimensions in mm/inch

1 Pipe (max. Ø 2 inches)

3 Transmitter TTF350

2 Pipe mount



Important

The wall and pipe installation set supports variable installation positions. A few examples of the different options are shown here. The mounting screw allows infinitely adjustable positioning (0° ... 360°) of the housing.

10 Ordering information

Field mounted Temperature Transmitter TTF350	Variant digit No.	1 - 7	8	9	10	11	12	Code			
	Catalog No.	TTF350-									
Explosion Protection											
Without explosion protection											
Type of Protection: Intrinsic Safety ATEX											
ATEX Zone 0: II 1 G EEx ia IIC T6											
ATEX Zone 1 (0): II 2 (1) G EEx [ia] ib IIC T6											
ATEX Zone 1 (20): II 2 G (1D) Ex [iaD] ib IIC T6											
Type of Protection: "nA" (Non-Sparking) ATEX											
ATEX Zone 2 / Zone 22: II 3 G EEx nA II T6 and II 3 D IP 65 T135°C											
Type of Protection: Intrinsic Safety FM & CSA											
FM IS, Class I, Div. 1+2, Groups A, B, C, D, Class II, E, F, G, Class III											
FM Class I, Zone 0, AEx ia IIC T6											
FM Non-Incendive, Class I, Div. 2, Groups A, B, C, D, Class II, E, F, G, Class III											
CSA IS, Class I, Div. 1+2, Groups A, B, C, D, Class II, E, F, G, Class III											
CSA Non-Incendive, Class I, Div. 2, Groups A, B, C, D, Class II, E, F, G, Class III											
Dust Explosion Protection ATEX											
ATEX Zone 20: II 1 D IP 65 T135°C											
ATEX Zone 0 / Zone 20: II 1 G EEx ia IIC T6 and II 1 D IP 65 T135°C											
Type of Protection: Flameproof Enclosures ATEX											
ATEX Zone 1: II 2 G EEx d IIC T6											
ATEX Zone 1 / Zone 0: II 2 G EEx d IIC T6 and II 1 G EEx ia IIC T6											
Type of Protection: Explosionproof, Non-Incendive, Dust-Ignitionproof FM & CSA											
FM XP, NI, DIP, Class I, II, III, Div. 1+2, Groups A-G, factory sealed											
CSA XP, NI, DIP, Class I, II, III, Div. 1+2, Groups A-G, factory sealed											
Housing / Display											
Dual-compartment housing / Without display (Aluminium)											
Dual-compartment housing / With LCD display HMI type B (Aluminium)											
Cable Entry											
Thread 3 x M20 x 1.5											
Thread 3 x 1/2 in. NPT											
Thread 3 x 3/4 in. NPT (via 1/2 in. > 3/4 in. adapter)											
Cable screw connection 3 x M20 x 1.5											
Communication Protocol											
HART											

Additional ordering information

TTF350	Code			
Configuration				
Customer specific configuration with report, except user curve	1)	BF		
Customer specific configuration with report, including user curve		BG		
Certificates				
SIL2 - Declaration of conformity		CS		
Calibration Certificate				
With 5-point works calibration certificate		EM		
Mounting Bracket				
Wall mounting / 2 in. pipe mounting bracket (Stainless steel)		K2		
Extended Ambient Temperature range				
-50 ... 85 °C		SE		
Device Identification Plate				
Stainless steel		T0		
Additional Tag Plate				
Stainless steel		I1		
Customer specific model acc. to NL no.				
(please specify)		Z9		

Accessories		Catalog No.			
NGV220-NO	Surge / Lightning protection for M20 x 1.5 cable glands, non-Ex version	see data sheet 10/63-6.15 EN			
NGV220-EX	Surge / Lightning protection for M20 x 1.5 cable glands, Ex version	see data sheet 10/63-6.15 EN			

1) (i. e. TAG number)

10.1 Order form configuration

Information on customer-specific configuration of temperature transmitter TTF350.

Configuration		Selection
Number of sensors		<input type="checkbox"/> 1 sensor (standard) <input type="checkbox"/> 2 sensors
Measurement type (for 2-sensor selection only)		<input type="checkbox"/> Redundancy/sensor backup <input type="checkbox"/> Sensor drift monitoring°C / K Sensor drift differentials time limit for drift overshoot <input type="checkbox"/> Differential measurement: Zero point where Ia = 4 mA <input type="checkbox"/> Differential measurement: Zero point where Ia = 12 mA <input type="checkbox"/> Mean
DIN IEC 60 751	RTD	<input type="checkbox"/> Pt10 <input type="checkbox"/> Pt50 <input type="checkbox"/> Pt100 (standard) <input type="checkbox"/> Pt200 <input type="checkbox"/> Pt500 <input type="checkbox"/> Pt1000 <input type="checkbox"/> Pt10 <input type="checkbox"/> Pt50 <input type="checkbox"/> Pt100 <input type="checkbox"/> Pt10 <input type="checkbox"/> Pt50 <input type="checkbox"/> Pt100 <input type="checkbox"/> Pt200 <input type="checkbox"/> Pt1000 <input type="checkbox"/> Ni50 <input type="checkbox"/> Ni100 <input type="checkbox"/> Ni120 <input type="checkbox"/> Ni1000 <input type="checkbox"/> Cu10 <input type="checkbox"/> Cu100
JIS C1604-81		
MIL-T-24388		
DIN 43760		
Cu		
	Linear Resistance measurement	<input type="checkbox"/> 0 ... 500 Ω <input type="checkbox"/> 0 ... 5000 Ω
IEC 584	Thermocouple	<input type="checkbox"/> Type K <input type="checkbox"/> Type J <input type="checkbox"/> Type N <input type="checkbox"/> Type R <input type="checkbox"/> Type S <input type="checkbox"/> Type T <input type="checkbox"/> Type E <input type="checkbox"/> Type B <input type="checkbox"/> Type L <input type="checkbox"/> Type U <input type="checkbox"/> Type C <input type="checkbox"/> Type D
DIN 43710		
ASTME 988		
	Linear voltage measurement	<input type="checkbox"/> -125 mV ... 125 mV <input type="checkbox"/> -125 mV ... 1100 mV
Sensor circuit (for RTD + resistance measurement only)		<input type="checkbox"/> 2-wire <input type="checkbox"/> 3-wire (standard) <input type="checkbox"/> 4-wire 2-wire circuit: Compensation of sensor-wire resistance max. 100 Ω <input type="checkbox"/> Sensor 1: Ω <input type="checkbox"/> Sensor 1: Ω
Reference junction (for thermocouples only)		<input type="checkbox"/> Internal (for standard thermocouple, except type B) <input type="checkbox"/> no (TC type B) <input type="checkbox"/> External/temp.: °C
Measuring range		<input type="checkbox"/> Measurement start: (Standard: 0) <input type="checkbox"/> Measurement end: (Standard: 100)
Unit		<input type="checkbox"/> Celsius (standard) <input type="checkbox"/> Fahrenheit <input type="checkbox"/> Rankine <input type="checkbox"/> Kelvin
Failure signalisation		<input type="checkbox"/> Overrange/22 mA (standard) <input type="checkbox"/> Underrange/3.6 mA
Damping (T ₆₃)		<input type="checkbox"/> Off (standard) <input type="checkbox"/> Seconds (1 sec. ... 100 sec.)
Sensor number		<input type="checkbox"/> Sensor 1..... <input type="checkbox"/> Sensor 2.....
Resistor value at 0°C / R ₀ Callendar van Dusen coefficient A Callendar van Dusen coefficient B Callendar van Dusen coefficient C (optional for RTD/Pt sensors only)		Sensor 1: R ₀ : Sensor 2: R ₀ : A: A: B: B: C: C:
User characteristics based on linearization table		<input type="checkbox"/> based on attached table of variate pairs
TAG number		<input type="checkbox"/> (max. 8 characters)
Software write protection		<input type="checkbox"/> Off (standard) <input type="checkbox"/> On
"Maintenance required" alarm pulse or continuous signaling (NE107)		<input type="checkbox"/> Off (standard) pulse widths (0.559.5 s increment 0.5 s) <input type="checkbox"/> continuous signal

Contact us

ABB Ltd.

Salterbeck Trading Estate
Workington, Cumbria
CA14 5DS
UK
Phone: +44 (0)1946 830 611
Fax: +44 (0)1946 832 661

ABB Inc.

125 E. County Line Road
Warminster PA 18974
USA
Phone: +1 215 674 6000
Fax: +1 215 674 7183

ABB Automation Products GmbH

Schillerstr. 72
32425 Minden
Germany
Phone: +49 551 905-534
Fax: +49 551 905-555

www.abb.com

Note

We reserve the right to make technical changes or modify the contents of this document without prior notice. With regard to purchase orders, the agreed particulars shall prevail. ABB does not accept any responsibility whatsoever for potential errors or possible lack of information in this document.

We reserve all rights in this document and in the subject matter and illustrations contained therein. Any reproduction, disclosure to third parties or utilization of its contents - in whole or in parts - is forbidden without prior written consent of ABB.

Copyright© 2010 ABB
All rights reserved