

Sensyflow FMT700-P Thermal Mass Flowmeter



Direct mass flow measurement of air

- No additional pressure and temperature compensation required

Wide measuring range of 1:40

Highest accuracy over the entire range

- Measured error < 1 % of measured value
- Factory-calibrated, with (optional) DKD calibration certificate

Amazingly quick response time < 12 ms

- Detection of rapid load changes on engine test benches

Low pressure loss

No moving parts, no wear, maintenance-free

Complete system with inlet/outlet runs, flow conditioner and links

- User-friendly handling
- Immediately ready for use
- DN 25 ... DN 200

Separate supply / evaluation unit with display, diagnostic functions and various signal outputs

- ASAM GDI interface optionally

Reference system for intake air measurement of the leading car manufacturers worldwide

Used in quality assurance, test bench applications, research and development

Contents

1	General information	3
1.1	Principle of operation and construction	3
2	Specifications	4
3	Electrical connections	6
3.1	BNC outputs and flowmeter sensor connection	6
3.2	SLOT 1: D-SUB connection „Serial Output“	6
3.3	SLOT 3: D-SUB connection „Totalizer“	7
3.4	SLOT 4: D-SUB connection „Analog Outputs“	8
4	Dimensions	9
4.1	Flowmeter sensor Sensyflow FMT700-P, DN 25	9
4.2	Flowmeter sensor Sensyflow FMT700-P, DN 50 ... DN 200	10
4.3	Supply / evaluation unit	11
4.4	Accessories	11
5	Ordering information	18

1 General information

1.1 Principle of operation and construction

Sensyflow FMT700-P operates according to the principle of a hot-film anemometer. With this measuring method the gas mass flow rate can be determined directly, without the need for pressure and temperature compensation.

The measuring system comprises a flowmeter sensor (measuring tube), a supply / evaluation unit, and a measuring section.

The sensor is designed as a measuring tube and accommodates the sensor unit and an electronic transmitter circuit. It is available in 6 nominal diameters ranging from DN 25 ... DN 200 and is installed in the measuring section by using quick-clamping connectors.

The measuring section consists of inlet and outlet sections of the appropriate size and of an air filter or flow conditioner which can be connected – e.g. to an air duct – via the connection piece on the suction side.

The supply / evaluation unit is available as a 19" plug-in version or as a desktop unit. It provides the power supply for the sensor and converts its flow-dependent current signal into standard analog mass flow signals.

The supply / evaluation unit with 6-digit display is suitable for all measuring tubes and automatically identifies the appropriate nominal diameter. Further diagnostic functions allow simple and safe operation. The measuring rate is adjustable according to measuring velocity or signal damping requirements. In case of high measuring velocity requirements the measuring rate can be reduced to 1 ms.

Available as option:

- Gas temperature measurement,
- Measuring value as standard volume flow,
- Serial interface,
- ASAM GDI interface,
- Connection for 2. sensor (measuring tube).

Physics of measurement

Thermal flow metering procedures use different ways to evaluate the flow dependent cooling of a heated resistor as measuring signal.

In a hotfilm anemometer with temperature difference control, the heated platinum resistor is maintained at a constant overtemperature in relation to an unheated platinum sensor inside the gas flow. The heating power required for maintaining the overtemperature depends directly on the flow rate and the material properties of the gas. With a known (and constant) gas composition the mass-flow can be determined by electronically evaluating the heater current / mass-flow curve without additional pressure and temperature compensation. Together with the standard density of the gas this results directly in the standard volume flow. Considering the high measuring range dynamics up to 1:40, an accuracy smaller than 1 % of the measuring value is achieved.

The gas stream flows past two temperature-sensitive resistors R_H and R_{MG} which are part of an electrical bridge circuit. Due to the chosen resistance ratio $R_H < R_{MG}$, R_H is heated by the current I_H , and R_{MG} adopts the same temperature as the gas. The current I_H is preset by the electronic control circuit to produce a constant temperature difference between the heated resistor R_H and the temperature of the gas.

The electrical power generated with resistor R_H exactly compensates its loss of heat to the gas flow. As this loss of heat is dependent on the number of particles which collide with the surface of resistor R_H , I_H represents a measure of the mass flow rate.



Abb. 1: Analog measuring principle

q_m	Gas mass-flow
R_{MG}	Gas temperature measuring resistor
R_H	Heating resistor
I_H	Actual value of heater

Typical applications

In a unique manner, Sensyflow FMT700-P mass flow meters for air combine high accuracy, huge turn-down ratio and extremely fast response time. These features qualify them for the following application fields:

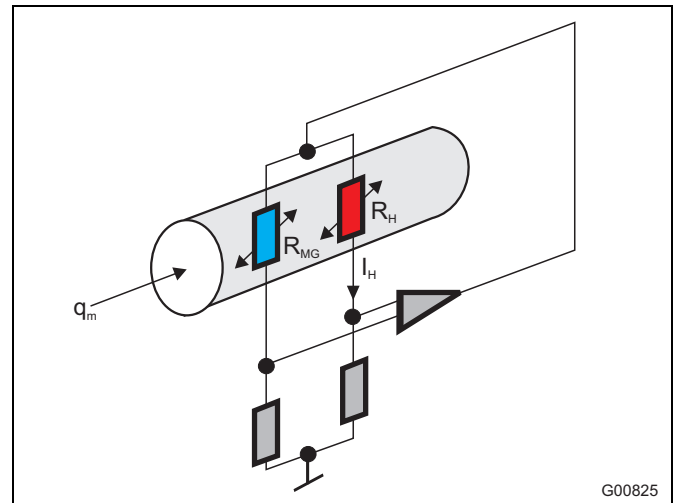
- Suction air measurements at combustion engines,
- Test benches for turbo chargers,
- Serial testing of flow dependent components like throttle valves, fans, air filters ...,
- Quality assurance: reference unit for other flow meters,
- Research and Development at universities and institutes.

Notes for ordering

The measuring system consists of the following components, which must be ordered separately:

1. Flowmeter sensor (measuring tube),
2. Supply / evaluation unit with measured value display unit,
3. Measuring section with air filter or flow conditioner,
4. Cables for connecting the sensor and the supply / evaluation unit.

2 Specifications

Measuring principle

Thermal: hot-film anemometer

Input

Measuring medium

Flow rate of air

Measuring ranges (standard)

Nominal diameter	kg/h
DN 25	0 ... 60
DN 50	0 ... 400
DN 80	0 ... 720
DN 100	0 ... 1200
DN 150	0 ... 2400
DN 200	0 ... 4000

Output

Output signals

Analog

0... 10 V	(< 4 mA)
0... 20 mA	(load < 500 Ω)
4... 20 mA	(load < 500 Ω)

Digital output

serial V24 / RS 232 C, electrically isolated
ASAM GDI interface

Characteristics

Accuracy

Measured error (including hysteresis and non-linearity)

< ± 1 % of measured value

Repeatability

< ± 0.25 % of measured value

Influences

Temperature effect

< 0.03 % / K of measured value

Pressure effect

≤ 0.2 % / 100 kPa (/bar) of measured value

Response time

T63 ≈ 12 ms

Pressure drop flowmeter sensor

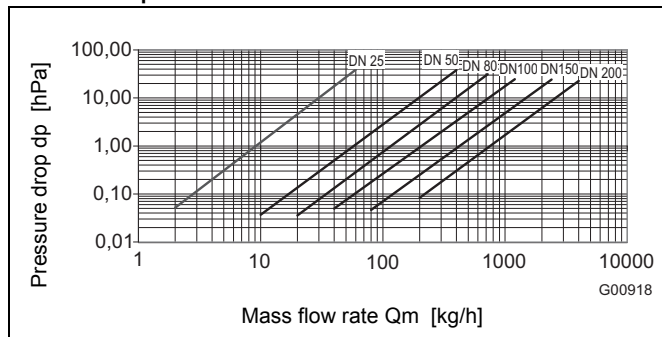

Fig. 2: Pressure drop under atmospheric conditions

Pressure drop of air filter

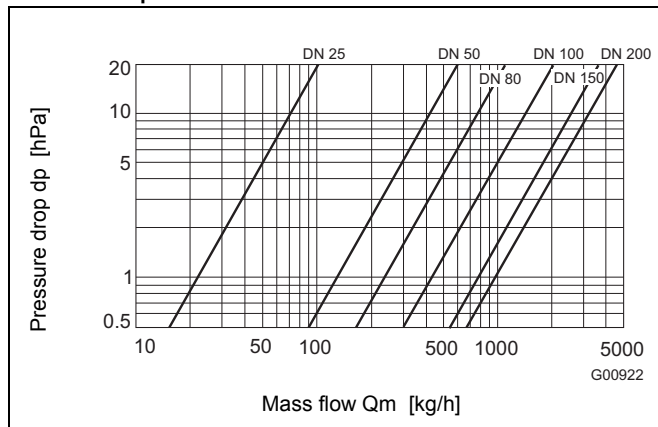

Fig. 3: Pressure drop of air filter

Operating conditions

Required steadying length

- Flow conditioner
- Inlet section 10 x D
- Outlet section 5 x D

Environmental conditions

Ambient temperature for sensor

-25 ... 80 °C (-13 ... 176 °F)

Ambient temperature for evaluation unit

-25 ... 50 °C (-13 ... 122 °F)

Storage temperature

-25 ... 85 °C (-13 ... 185 °F)

Type of protection

IP 54 (sensor)

Measuring medium conditions

Measured medium temperature

-25 ... 80 °C (-13 ... 176 °F)

Operating pressure

Standard: 0.6 ... 2.5 x 102 kPa (2.5 bar abs.)

Option: 0.6 ... 8 x 102 kPa (8 bar abs.)

only DN 25

3 Electrical connections

3.1 BNC outputs and flowmeter sensor connection

<p>BNC outputs Current output: 0 (4) ... 20 mA Voltage output: 0 ... 10 V</p>	 <p>G00923</p>
<p>Flowmeter sensor connection 1 = Temperature signal 2 = Flow signal 3 = Supply voltage (+ 18 V) 4 = Flowmeter sensor coding 2⁰ 5 = Flowmeter sensor coding 2¹ 6 = Flowmeter sensor coding 2² 7 = Flowmeter sensor coding 2³</p>	 <p>G00924</p>

Fig. 4: Terminal connection of BNC socket and flowmeter sensor socket

3.2 SLOT 1: D-SUB connection „Serial Output“

Pin	Assignment	Pin	Assignment
1	-	14	-
2	TxD Transmi data	15	-
3	RxD Receive data	16	-
4	-	17	-
5	-	18	-
6	-	19	-
7	GND	20	-
8	-	21	-
9	-	22	-
10	-	23	-
11	-	24	-
12	-	25	-
13	-		

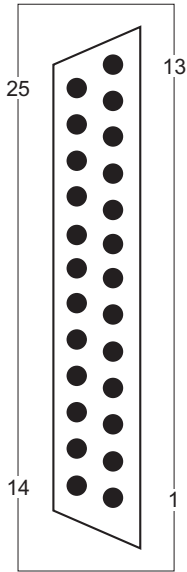

G00925

Fig. 5: Terminal connection of 25-pole D-SUB connection „Serial Output“

3.3 SLOT 3: D-SUB connection „Totalizer“

Pin	Assignment	Pin	Assignment
1	2 ⁰ LSB ¹⁾	14	2 ¹³
2	2 ¹	15	2 ¹⁴ MSB ²⁾
3	2 ²	16	
4	2 ³	17	
5	2 ⁴	18	
6	2 ⁵	19	
7	2 ⁶	20	
8	2 ⁷	21	
9	2 ⁸	22	
10	2 ⁹	23	REMOTE-CTRL ^{START/STOP}
11	2 ¹⁰	24	U _{ext.}
12	2 ¹¹	25	GND _{ext.}
13	2 ¹²		1) ¹⁾ LSB = Least Significant Bit 2) ²⁾ MSB = Most Significant Bit

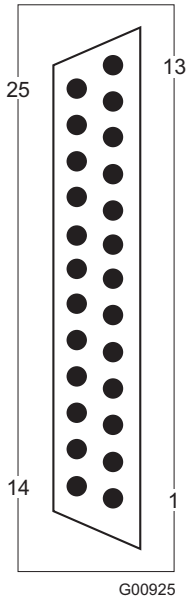

Fig. 6: Terminal connection of 25-pole D-SUB connection „Totalizer“

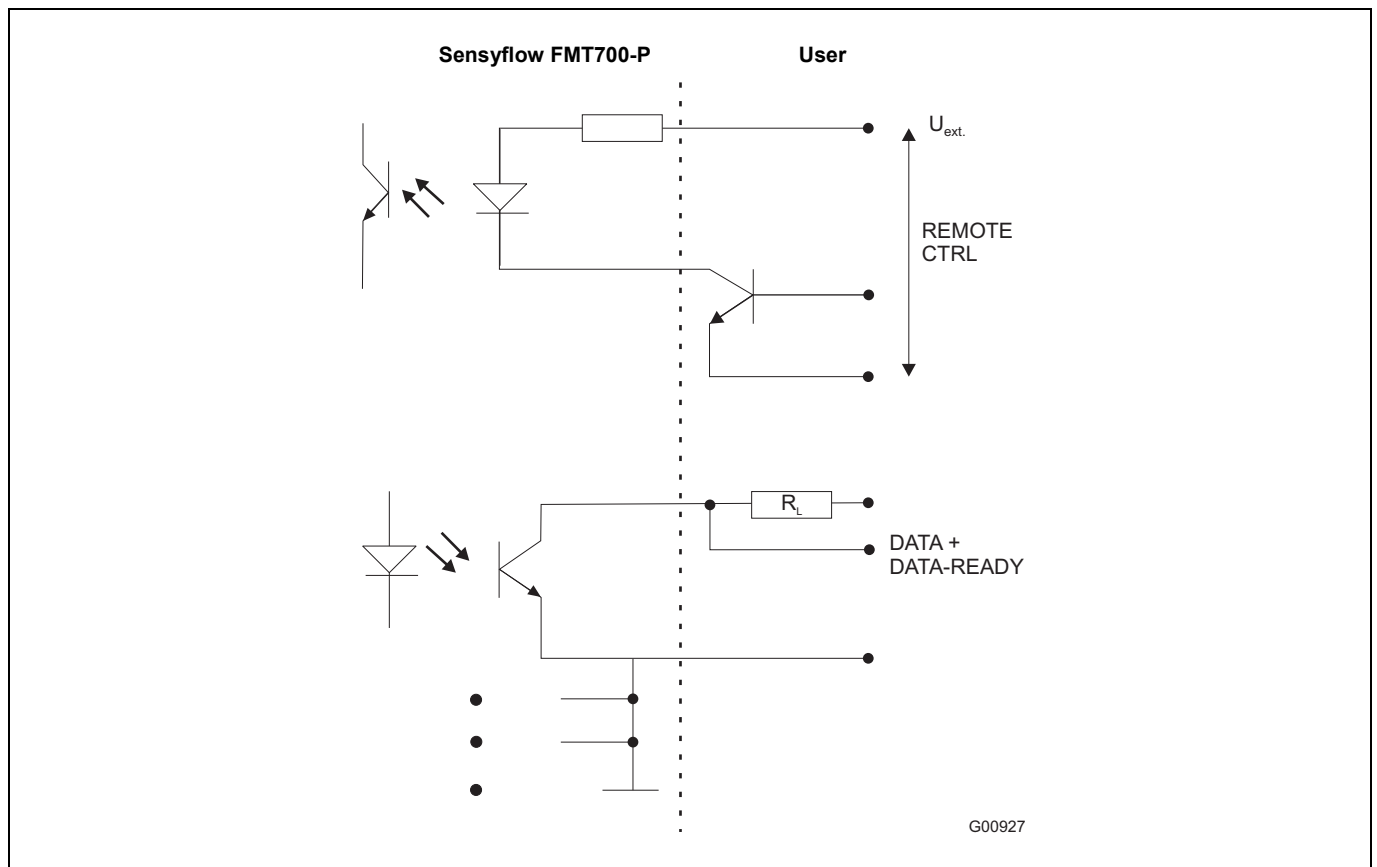

Fig. 7: Terminal connection of inputs / outputs

3.4 SLOT 4: D-SUB connection „Analog Outputs“

Pin	Assignment	Pin	Assignment
1	GND	14	Iout GND
2	Iout+	15	Uout GND
3	Uout+	16	GND
4	Flowmeter sensor coding	17	Flowmeter sensor coding
5	Nominal diameter coding	18	Nominal diameter coding
6	Nominal diameter coding	19	Nominal diameter coding
7	Free coding	20	Free coding
8	Free coding	21	Free coding
9	-	22	-
10	-	23	-
11	Temp. 1 +	24	Temp. 1 -
12	Temp. 2 +	25	Temp. 2 -
13	GND _{ext.}		

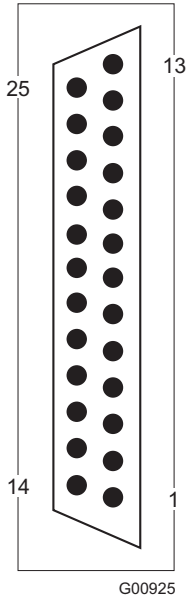

Fig. 8: Terminal connection of 25-pole D-SUB connection „Analog Outputs“

Digital coding of the flowmeter sensor

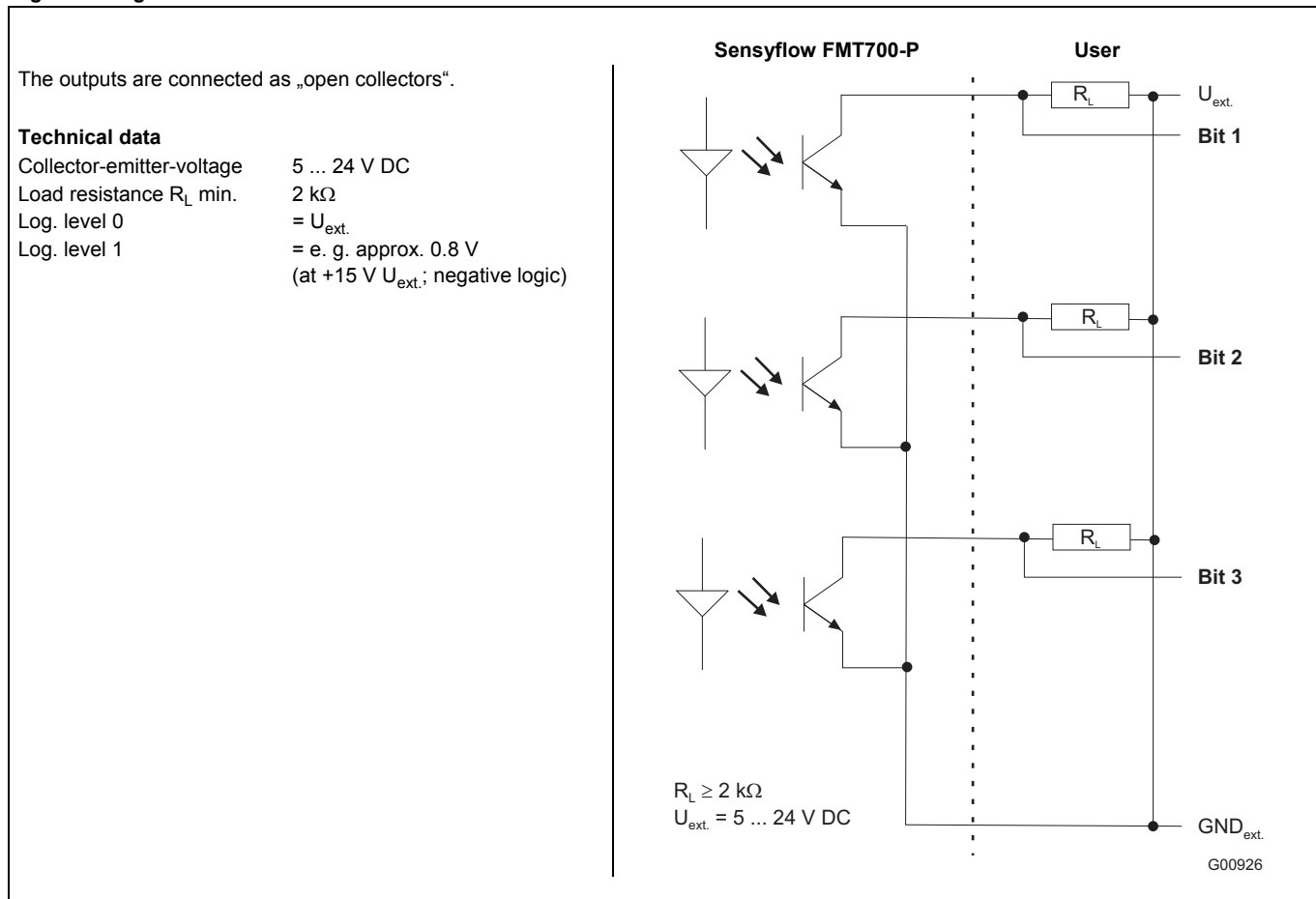

Fig. 9: Terminal connection of open-collector outputs for flowmeter sensor coding

Nominal diameter coding

	Pin 5	Pin 18	Pin 6	Pin 19	Hex
No measuring tube	0	0	0	0	00
DN 25	1	1	0	0	30
DN 50	1	0	1	0	50
DN 80	1	1	1	0	70
DN 100	1	0	0	1	90
DN 150	1	1	0	1	B0
DN 200	1	0	1	1	D0
Special	1	1	1	1	F0

	Pin 4	Pin 17
Flowmeter sensor 1	1	1
Flowmeter sensor 2	1	0
Medium temperature flowmeter sensor 1	0	1
Medium temperature flowmeter sensor 2	0	0

4 Dimensions

4.1 Flowmeter sensor Sensyflow FMT700-P, DN 25

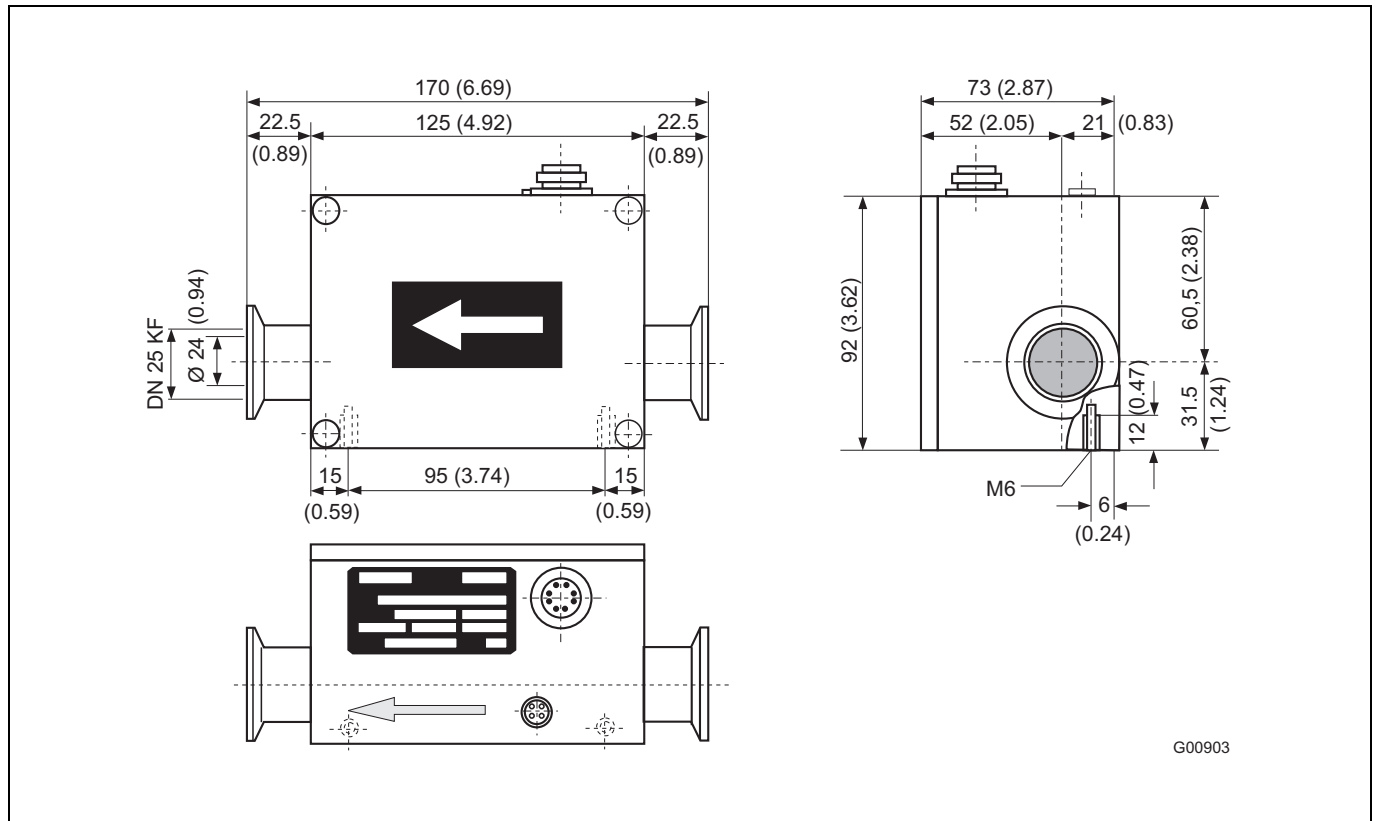

Fig. 10: Dimensions in mm (inch)

4.2 Flowmeter sensor Sensyflow FMT700-P, DN 50 ... DN 200

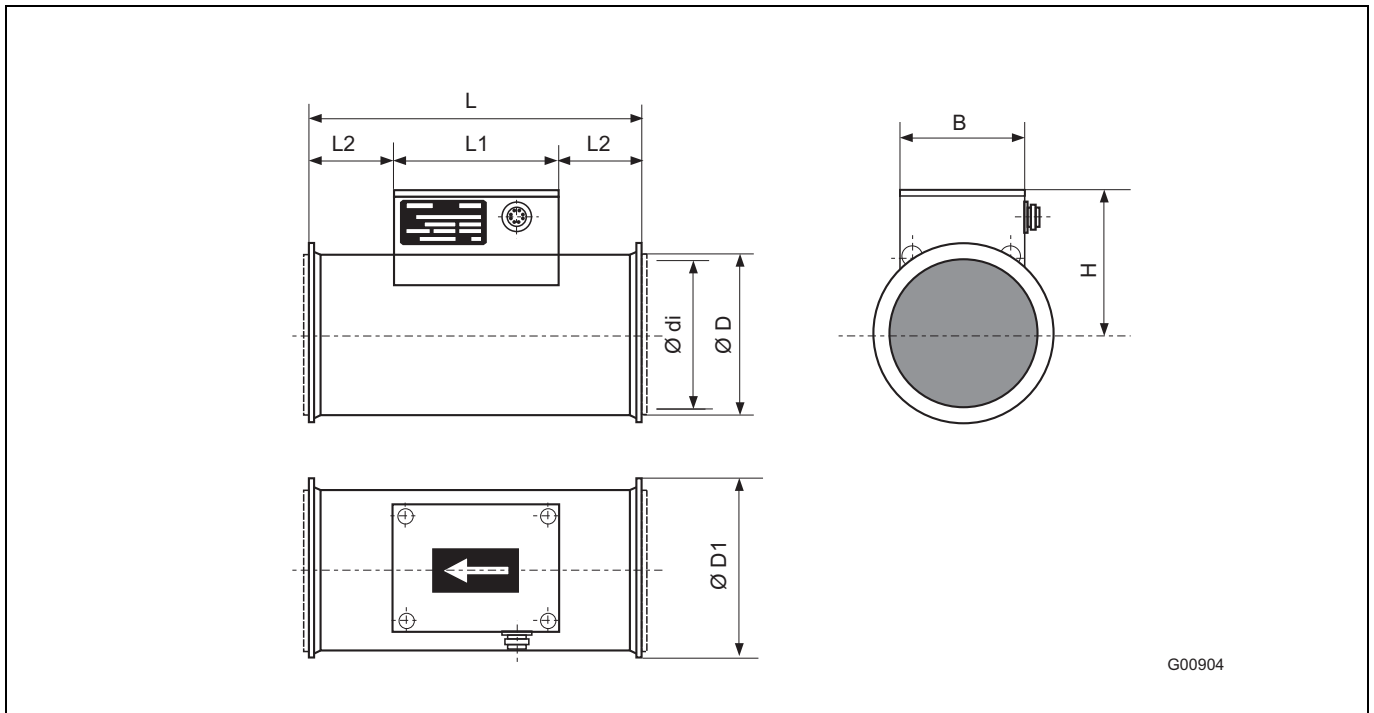

Fig. 11: Dimensions in mm (inch)

DN	Ø D	Ø D1	Ø di	L	L1	L2	B	H
50	64 (2.52)	80.0 (3.15)	58 (2.28)	184 (7.24)	125 (4.92)	29.5 (1.16)	92 (3.62)	88.0 (3.46)
80	89 (3.50)	108.5 (4.27)	80 (3.15)	189 (7.44)		32.0 (1.26)		98.5 (3.88)
100	118 (4.65)	132.5 (5.22)	110 (4.33)	254 (10.00)		64.5 (2.54)		114.0 (4.49)
150	158 (6.22)	180.0 (7.09)	153 (6.02)	280 (11.02)		77.5 (3.05)		136.0 (5.35)
200	205.6 (8.09)	240.0 (9.45)	200 (8)	330 (12.99)		102.5 (4.04)		161.5 (6.36)

Dimensions in mm (inch)

4.3 Supply / evaluation unit

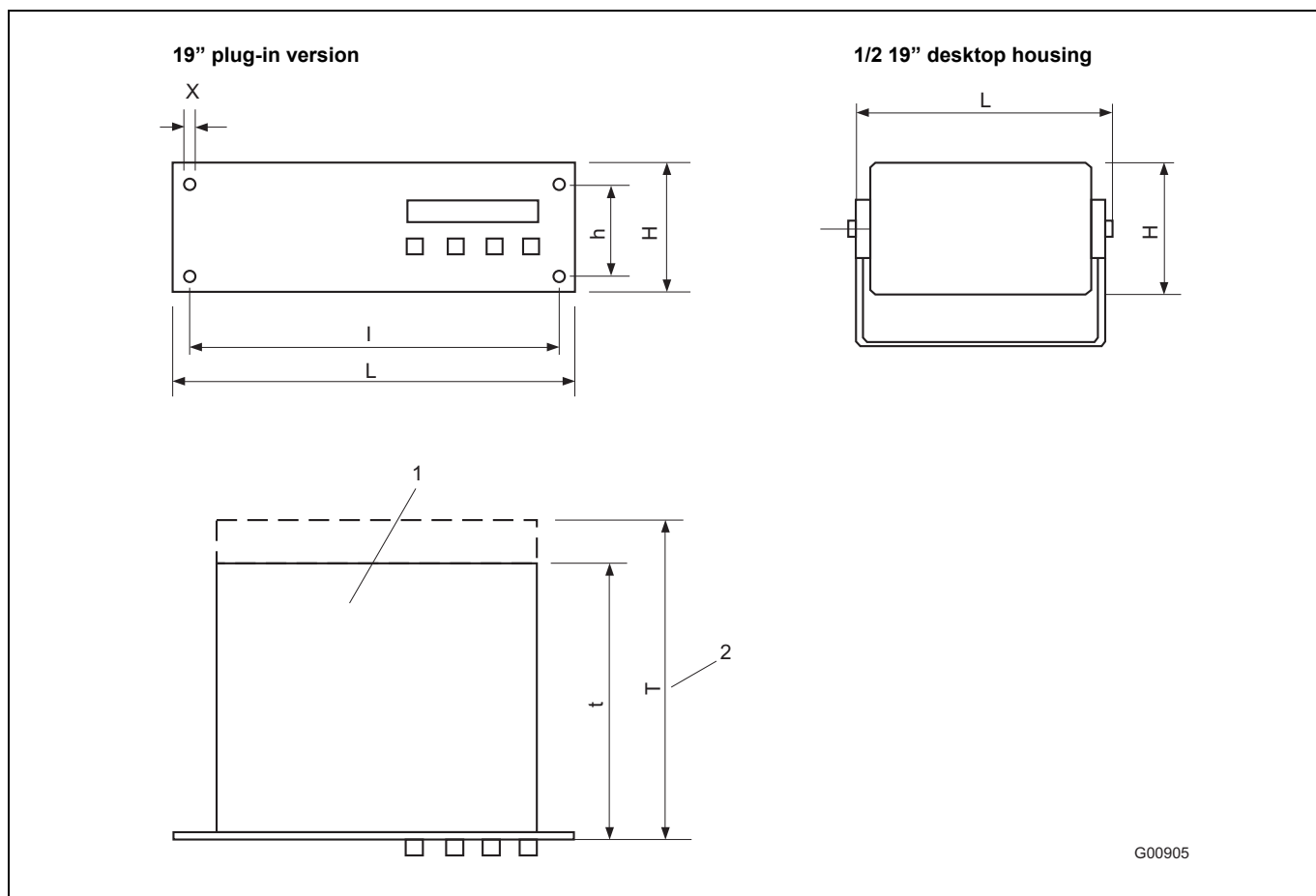

Fig. 12

- 1 Required cutout for 19" unit: 450 x 131 mm (17.72 x 5.16 inch)
- 2 For wiring

Unit	Dimensions	L	l	H	h	T	t	X
1/2 19" desktop housing		310 (12.2)	-	140 (5.5)	-	-	-	-
19" plug-in version		483 (19.0)	462 (18.2)	132 (5.2)	58 (2.3)	425 (16.7)	325 (12.8)	M6

Dimensions in mm (inch)

4.4 Accessories

In order to simplify the installation of our measuring system for the user, we recommend to apply approved components from our extensive accessories program.

Tubes of different lengths as inlet section or outlet section are available which can be combined with an air filter.

We recommend an undisturbed inlet section of 10 x D, a outlet section of 5 x D and the application of an air filter (this combination represents the calibration set of the manufacturer).

D = tube diameter.

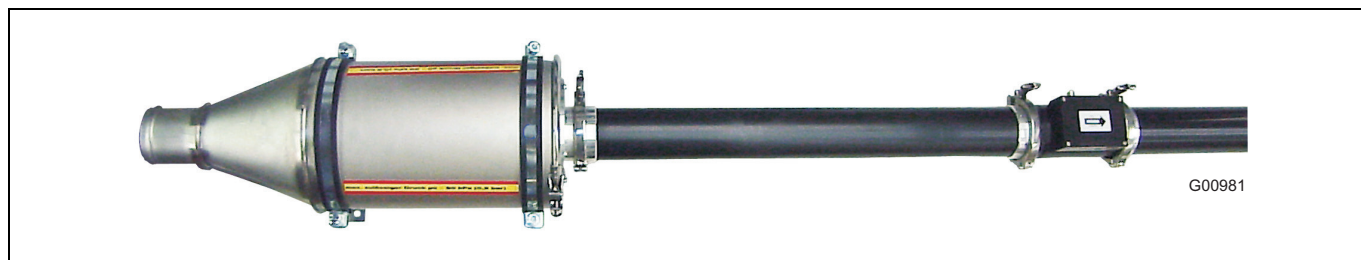
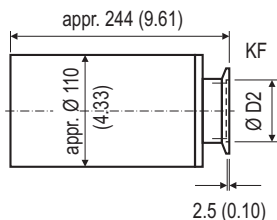

Fig. 13: Standard measuring section: measuring section 3

Modules DN 25

KF = ISO KF flange (ISO small flange)

①
Air filter (open)
with flange



②
10 x D inlet section
with flanges
(on both sides)

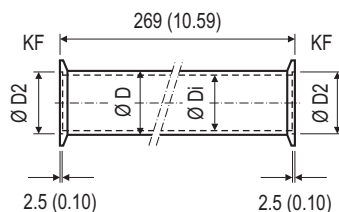

③
5 x D outlet section
with flanges
(on both sides)

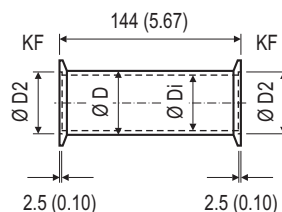

⑥
Hose adapter
with flange
(on one side)

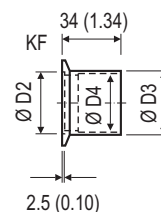

④
10 x D inlet section
with flange
(on one side)

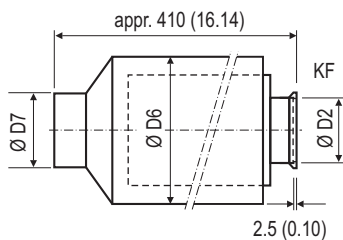

⑤
5 x D outlet section
with flange
(on one side)

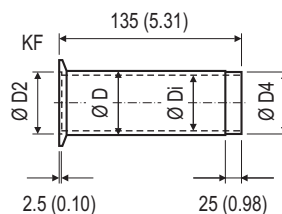
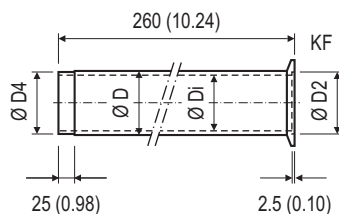

Standard measuring section

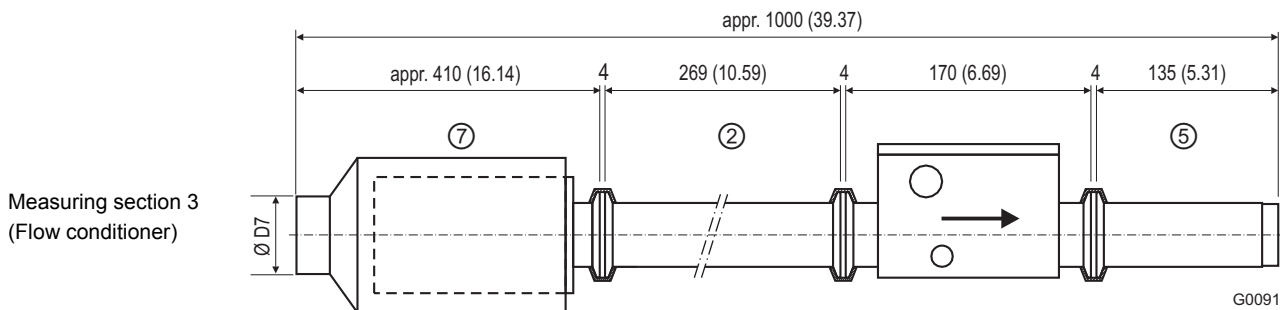

G00912

Fig. 14: Dimensions in mm (inch)

DN	Ø D	Ø D2	Ø D3	Ø D4	Ø D6	Ø D7	Ø Di
25	32 (1.26)	26.1 (1.03)	30 (1.18)	27 (1.06)	appr. 150 (5.91)	60 (2.36)	24 (0.94)

Dimensions in mm (inch)

Modules DN 25

KF = ISO KF flange (ISO small flange)

⑫
O-ring



⑬
Clamping ring
FL-special

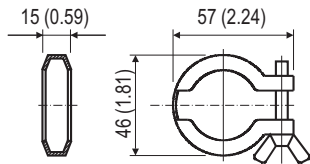

⑪
Inner
center ring

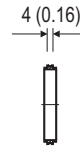

⑭
Clamping ring
FL-Optimal AS

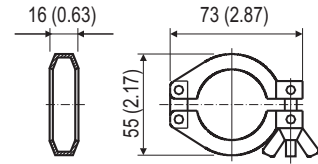

⑥ ⑪ / ⑫ ⑥

Sectional detail pipe connection
(without clamping ring)

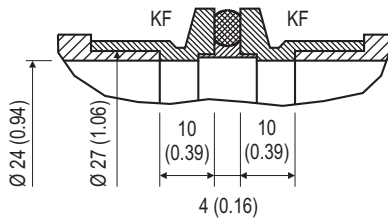

Individual planning

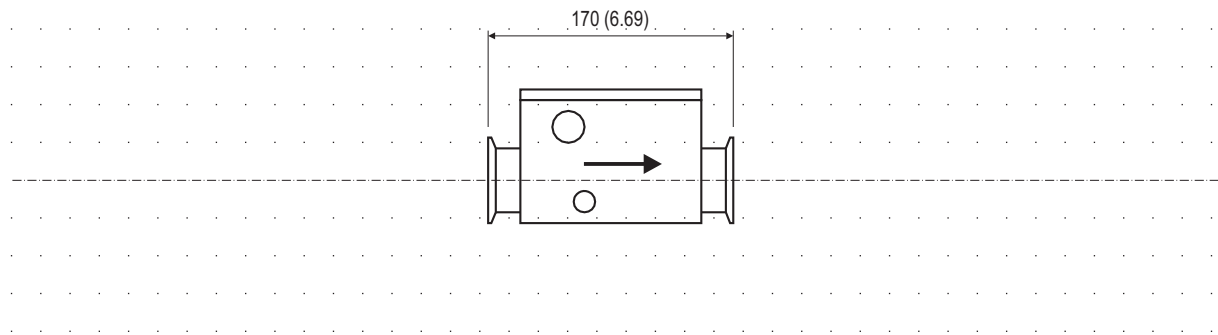

G00919

Abb. 15: Dimensions in mm (inch)

Modules DN 50 ... DN 100

KOF = Tapered flange (with recessed face and groove for O-ring)
ZWF = Intermediate flange (with raised face)

①

Air filter (open)
with flange

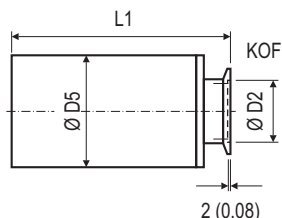

②

10 x D inlet section
with flanges
(on both sides)

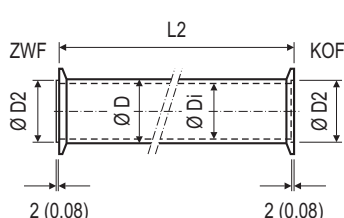

③

5 x D outlet section
with flanges
(on both sides)

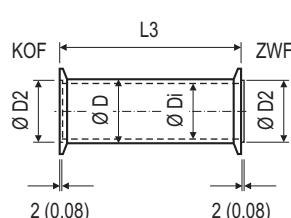

⑥

Hose adapter
with flange
(on one side)

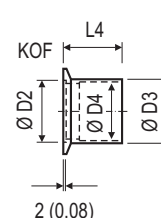

⑦

Flow conditioner
with flange

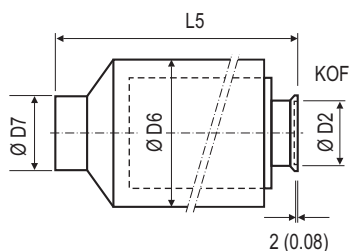

④

10 x D inlet section
with flange
(on one side)

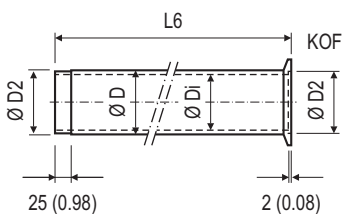

⑤

5 x D outlet section
with flange
(on one side)

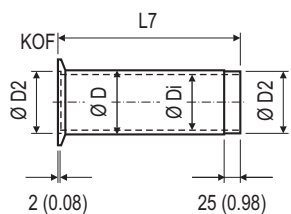

Standard measuring section

Measuring section 3
(Flow conditioner)

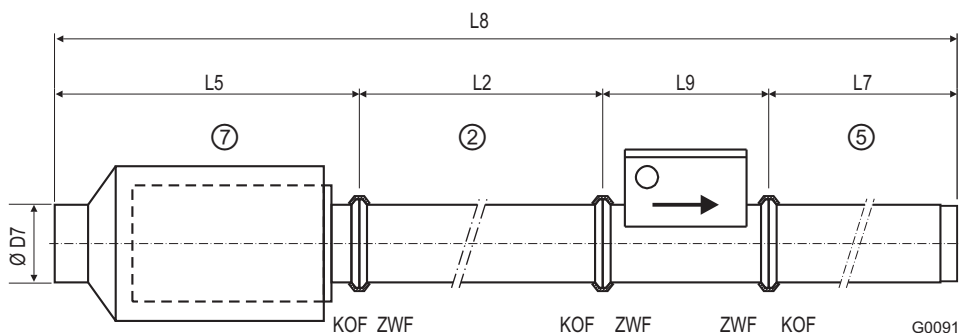

Fig. 16: Dimensions in mm (inch)

DN	L1	L2	L3	L4	L5	L6	L7	L8	L9
50	appr. 356 (14.02)	506 (19.92)	256 (10.08)	50 (1.97)	appr. 660 (25.98)	504 (19.84)	254 (10.00)	appr. 1600 (62.99)	184 (7.24)
80	appr. 401 (15.79)	806 (31.73)	406 (15.98)	80 (3.15)	appr. 740 (29.13)	804 (31.65)	404 (15.91)	appr. 2140 (84.25)	189 (7.44)
100	appr. 526 (20.71)	1006 (39.61)	506 (19.92)	100 (3.94)	appr. 840 (33.07)	1004 (39.53)	504 (19.84)	appr. 2610 (102.76)	254 (10.00)

DN	Ø D	Ø D2	Ø D3	Ø D4	Ø D5	Ø D6	Ø D7	Ø Di
50	66 (2.60)	64 (2.52)	70 (2.76)	60 (2.36)	appr. 150 (5.91)	appr. 200 (7.87)	78 (3.07)	58 (2.28)
80	91 (3.58)	89 (3.50)	95 (3.74)	85 (3.35)	appr. 200 (7.87)	appr. 250 (9.84)	98 (3.86)	80 (3.15)
100	119 (4.69)	118 (4.65)	122 (4.80)	114 (4.49)	appr. 240 (9.45)	appr. 300 (11.81)	148 (5.83)	110 (4.33)

Dimensions in mm (inch)

Modules DN 50 ... DN 100

KOF = Tapered flange (with recessed face and groove for O-ring)

ZWF = Intermediate flange (with raised face)

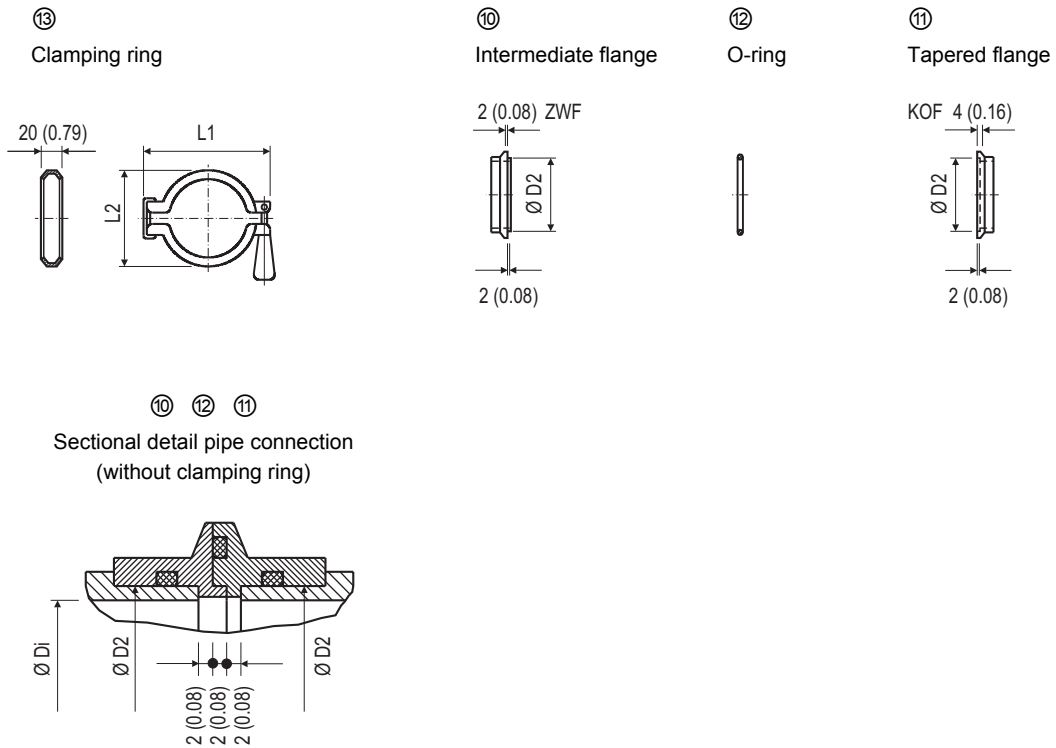

Individual planning

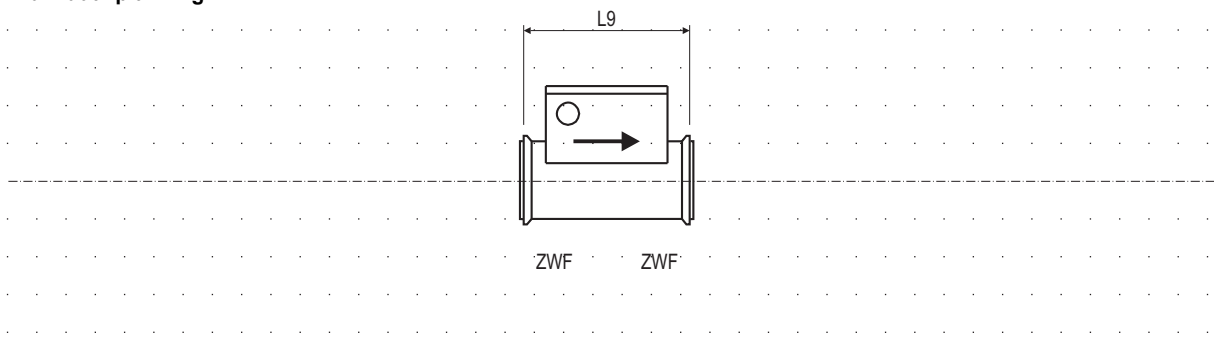

G00920

Fig. 17: Dimensions in mm (inch)

DN	L1	L2	L9	Ø D2	Ø Di
50	102 (4.02)	72 (2.83)	184 (7.24)	64 (2.52)	58 (2.28)
80	145 (5.71)	114 (4.49)	189 (7.44)	89 (3.50)	80 (3.15)
100	158 (6.22)	127 (5.00)	254 (10.00)	118 (4.65)	110 (4.33)

Dimensions in mm (inch)

Modules DN 150 ... DN 200

KOF = Tapered flange (with raised face and groove for O-ring)

ZWF = Intermediate flange (with recessed face)

①

Air filter (open)
with flange

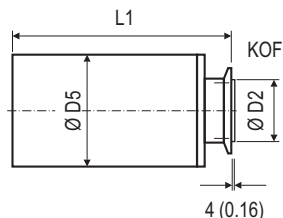

②

10 x D inlet section
with flanges
(on both sides)

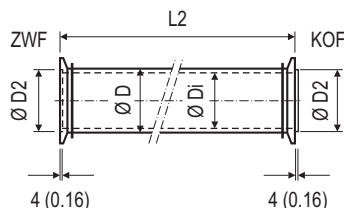

③

5 x D outlet section
with flanges
(on both sides)

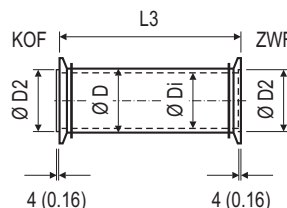

④

Hose adapter
with flange
(on one side)

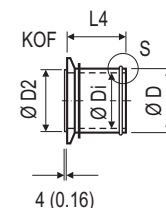

⑦

Flow conditioner
with flange

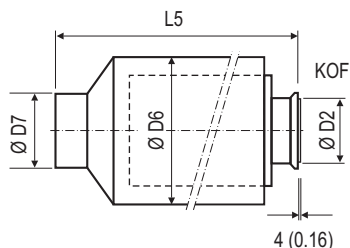

④

10 x D inlet section
with flange
(on one side)

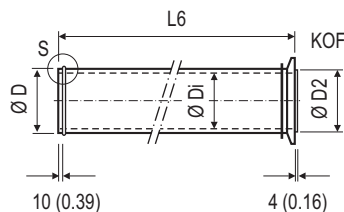

⑤

5 x D outlet section
with flange
(on one side)

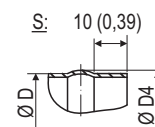
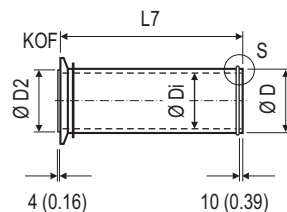

Standard measuring section

Measuring section 3
(Flow conditioner)

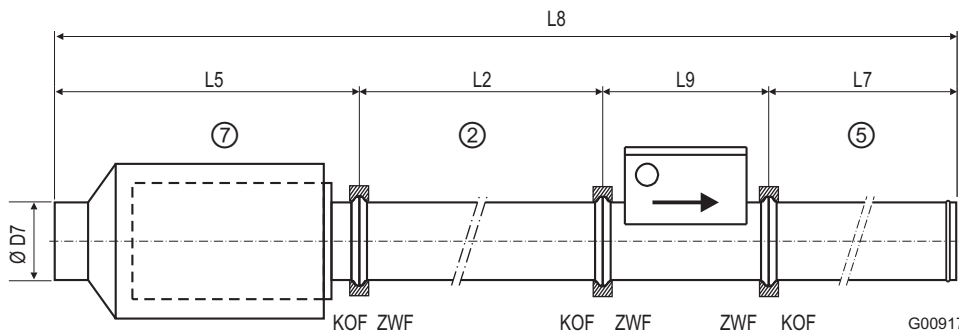

Fig. 18: Dimensions in mm (inch)

DN	L1	L2	L3	L4	L5	L6	L7	L8	L9
150	appr. 513 (20.20)	1518 (59.76)	768 (30.24)	159 (6.26)	appr. 900 (35.43)	1509 (59.41)	759 (29.88)	appr. 3460 (136.22)	280 (11.02)
200	appr. 513 (20.20)	2018 (79.49)	1018 (40.08)	159 (6.26)	appr. 850 (33.46)	2009 (79.09)	1018 (40.08)	appr. 4220 (166.14)	330 (12.99)

DN	Ø D	Ø D2	Ø D4	Ø D5	Ø D6	Ø D7	Ø Di
150	151 (5.94)	158 (6.22)	153 (6.02)	appr. 300 (11.81)	appr. 350 (13.78)	198 (7.80)	149 (5.87)
200	202 (7.95)	205 (8.07)	204 (8.03)	appr. 300 (11.81)	appr. 350 (13.78)	248 (9.76)	200 (7.87)

Dimensions in mm (inch)

Modules DN 150 ... DN 200

KOF = Tapered flange (with raised face and groove for O-ring)

ZWF = Intermediate flange (with recessed face)

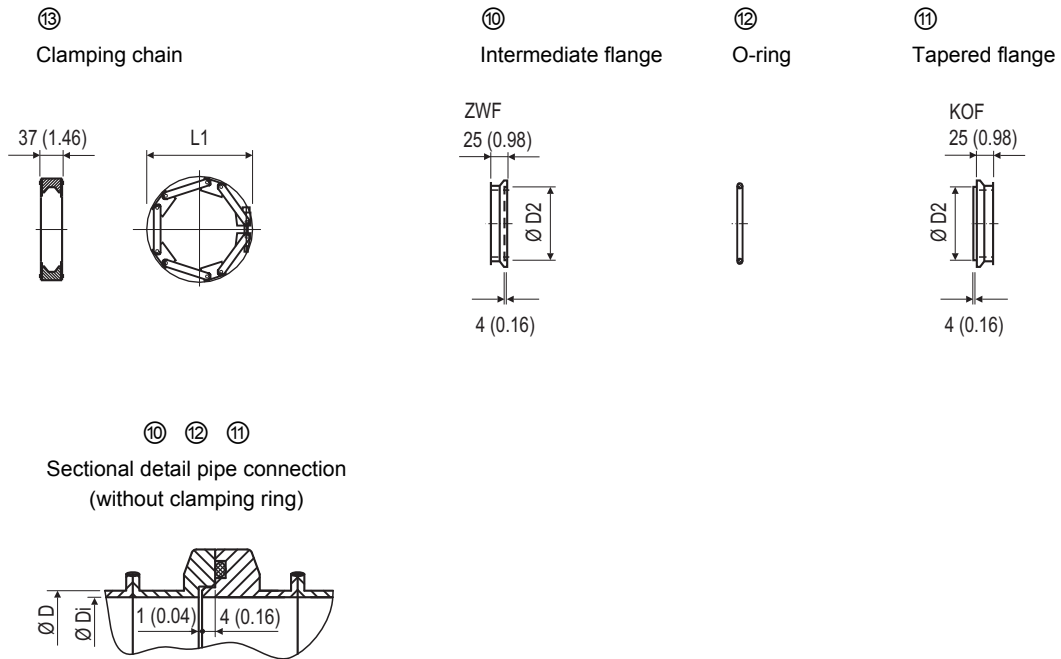

Individual planning

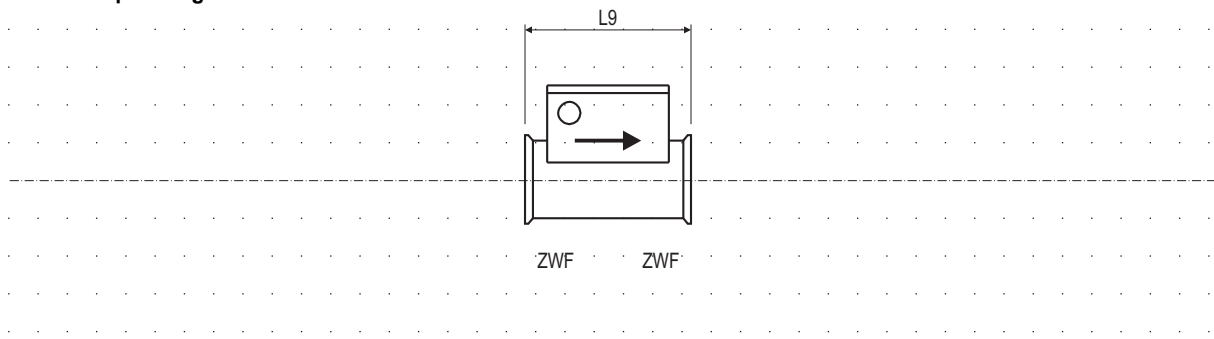

G00921

Fig. 19: Dimensions in mm (inch)

DN	L1	L9	Ø D	Ø Di
150	appr. 220 (8.66)	280 (11.02)	151 (5.94)	149 (5.87)
200	appr. 280 (11.02)	330 12.99()	202 (7.95)	200 (7.87)

Dimensions in mm (inch)

5 Ordering information

	Main Code													Add. Code
	Variant digit No.	1 - 6	7	8	9	10	11	12	13					
Sensyflow FMT700-P Thermal Mass Flowmeter, Supply / Evaluation Unit	V14243		X	X	X	X	X	X	X	X	X	X	X	XXX
Number of Connectable Sensors														
1 sensor			1											
2 sensors, "stand by" power supply, fast sensor switching possible			2											
Design														
19 in. plug-in card			1)	1										
1/2 19 in. desktop housing			2)	2										
Power supply														
230 V AC						1								
115 V AC						2								
Digital Interface														
Without								0						
V24 / RS 232 C, serial								1						
ASAM-GDI and V24 / RS 232 C, serial								2						
Operating Mode														
Standard									0					
Totalizer									3)	1				
Output Signal														
0 ... 10 V												1	0	
0 ... 10 V and 0 ... 20 mA												4	0	
0 ... 10 V and 4 ... 20 mA												5	0	
Second Display Unit														
Switchable to g/s														401
Switchable to Nm ³ /h, at 0 °C (32 °F) and 1013 mbar (101.3 kPa / 14.69 psi)														402
Switchable to Nm ³ /h, at 20 °C (68 °F) and 1013 mbar (101.3 kPa / 14.69 psi)														403
Switchable to NI/s, at 0 °C (32 °F) and 1013 mbar (101.3 kPa / 14.69 psi)														404
Switchable to NI/s, at 20 °C (68 °F) and 1013 mbar (101.3 kPa / 14.69 psi)														405
Switchable to NI/min, at 0 °C (32 °F) and 1013 mbar (101.3 kPa / 14.69 psi)														406
Temperature Display														
For 1 sensor														411
For 2 sensors														412
Language of Documentation														
German														M1
English														M5
Zubehör														
FMT700-P supply / evaluation unit, later implementation of ASAM-GDI including certification, (only in combination with serial interface)														7962840
FMT700-P supply / evaluation unit for 1 sensor, 19 in. plug-in housing, preferred version, completely configured														7964113
FMT700-P supply / evaluation unit for 1 sensor, 1/2 19 in. desktop housing preferred version, completely configured														7964114

- 1) Weight 7.0 kg (15.4 lb)
 2) Weight 7.3 kg (16.1 lb)
 3) Only with V24 / RS 232 C interface

Sensyflow FMT700-P Thermal Mass Flowmeter Sensor	Code
FMT700-P Thermal Mass Flowmeter Sensor, standard characteristic curve, for air, test benches, nominal diameter DN 25	7962633
FMT700-P Thermal Mass Flowmeter Sensor, standard characteristic curve, for air, test benches, nominal diameter DN 50	7962634
FMT700-P Thermal Mass Flowmeter Sensor, standard characteristic curve, for air, test benches, nominal diameter DN 80	7962635
FMT700-P Thermal Mass Flowmeter Sensor, standard characteristic curve, for air, test benches, nominal diameter DN 100	7962636
FMT700-P Thermal Mass Flowmeter Sensor, standard characteristic curve, for air, test benches, nominal diameter DN 150	7962637
FMT700-P Thermal Mass Flowmeter Sensor, standard characteristic curve, for air, test benches, nominal diameter DN 200	7962638
FMT700-P Thermal Mass Flowmeter Sensor, special characteristic curve, for air, test benches, nominal diameter DN 25	7962639
FMT700-P Thermal Mass Flowmeter Sensor, special characteristic curve, for air, test benches, nominal diameter DN 50	7962640
FMT700-P Thermal Mass Flowmeter Sensor, special characteristic curve, for air, test benches, nominal diameter DN 80	7962641
FMT700-P Thermal Mass Flowmeter Sensor, special characteristic curve, for air, test benches, nominal diameter DN 100	7962642
FMT700-P Thermal Mass Flowmeter Sensor, special characteristic curve, for air, test benches, nominal diameter DN 150	7962643
FMT700-P Thermal Mass Flowmeter Sensor, special characteristic curve, for air, test benches, nominal diameter DN 200	7962644
SMD130 DKD Calibration of Thermal Mass Flowmeters, certificate of calibration with air, PTB approved DKD calibration facility No. 05701	3KXS310130S1001

Accessories	Code
FMT700-P Measuring section	
FMT700-P measuring section 1, nominal diameter DN 25	7962645
FMT700-P measuring section 1, nominal diameter DN 50	7962646
FMT700-P measuring section 1, nominal diameter DN 80	7962647
FMT700-P measuring section 1, nominal diameter DN 100	7962648
FMT700-P measuring section 1, nominal diameter DN 150	7962649
FMT700-P measuring section 1, nominal diameter DN 200	7962650
FMT700-P measuring section 3, nominal diameter DN 25, suction side DN 60	7964107
FMT700-P measuring section 3, nominal diameter DN 50, suction side DN 80	7964108
FMT700-P measuring section 3, nominal diameter DN 80, suction side DN 100	7964109
FMT700-P measuring section 3, nominal diameter DN 100, suction side DN 150	7964110
FMT700-P measuring section 3, nominal diameter DN 150, suction side DN 200	7964111
FMT700-P measuring section 3, nominal diameter DN 200, suction side DN 250	7964112
FMT700-P Sensor cable	
FMT700-P sensor cable, length 3 m	7962693
FMT700-P sensor cable, length 8 m	7962694
FMT700-P sensor cable, length 15 m	7962695
FMT700-P sensor cable, length 30 m	7962696
FMT700-P interface cable, length 3 m, with 1 connector 25-pin	7962697
FMT700-P Air filter ①	
FMT700-P air filter (open) with flange, nominal diameter DN 25	7962657
FMT700-P air filter (open) with flange, nominal diameter DN 50	7962658
FMT700-P air filter (open) with flange, nominal diameter DN 80	7962659
FMT700-P air filter (open) with flange, nominal diameter DN 100	7962660
FMT700-P air filter (open) with flange, nominal diameter DN150	7962661
FMT700-P air filter (open) with flange, nominal diameter DN 200	7962662
FMT700-P Flow conditioner ⑦	
FMT700-P flow conditioner with flange, nominal diameter DN 25, suction side DN 60	7964101
FMT700-P flow conditioner with flange, nominal diameter DN 50, suction side DN 80	7964102
FMT700-P flow conditioner with flange, nominal diameter DN 80, suction side DN 100	7964103
FMT700-P flow conditioner with flange, nominal diameter DN 100, suction side DN 150	7964104
FMT700-P flow conditioner with flange, nominal diameter DN 150, suction side DN 200	7964105
FMT700-P flow conditioner with flange, nominal diameter DN 200, suction side DN 250	7964106

Accessories	Code
FMT700-P Inlet section ② FMT700-P inlet section 10 x D, nominal diameter DN 25, 2 ISO KF flanges, 1 clamping ring FMT700-P Inlet section 10 x D, nominal diameter DN 50, 1 tapered flange, 1 intermediate flange, 1 clamping ring FMT700-P inlet section 10 x D, nominal diameter DN 80, 1 tapered flange, 1 intermediate flange, 1 clamping ring FMT700-P inlet section 10 x D, nominal diameter DN 100, 1 tapered flange, 1 intermediate flange, 1 clamping ring FMT700-P inlet section 10 x D, nominal diameter DN 150, 1 tapered flange, 1 intermediate flange, 1 clamping chain FMT700-P inlet section 10 x D, nominal diameter DN 200, 1 tapered flange, 1 intermediate flange, 1 clamping chain	7962663 7962664 7962665 7962666 7962667 7962668
FMT700-P Inlet section ④ FMT700-P inlet section 10 x D, nominal diameter DN 25, 1 ISO KF flange, 1 clamping ring FMT700-P inlet section 10 x D, nominal diameter DN 50, 1 tapered flange, 1 clamping ring FMT700-P inlet section 10 x D, nominal diameter DN 80, 1 tapered flange, 1 clamping ring FMT700-P inlet section 10 x D, nominal diameter DN 100, 1 tapered flange, 1 clamping ring FMT700-P inlet section 10 x D, nominal diameter DN 150, 1 tapered flange, 1 clamping chain FMT700-P inlet section 10 x D, nominal diameter DN 200, 1 tapered flange, 1 clamping chain	7962669 7962670 7962671 7962672 7962673 7962674
FMT700-P Outlet section ③ FMT700-P outlet section 5 x D, nominal diameter DN 25, 2 ISO KF flanges, 1 clamping ring FMT700-P outlet section 5 x D, nominal diameter DN 50, 1 tapered flange, 1 intermediate flange, 1 clamping ring FMT700-P outlet section 5 x D, nominal diameter DN 80, 1 tapered flange, 1 intermediate flange, 1 clamping ring FMT700-P outlet section 5 x D, nominal diameter DN 100, 1 tapered flange, 1 intermediate flange, 1 clamping ring FMT700-P outlet section 5 x D, nominal diameter DN 150, 1 tapered flange, 1 intermediate flange, 1 clamping chain FMT700-P outlet section 5 x D, nominal diameter DN 200, 1 tapered flange, 1 intermediate flange, 1 clamping chain	7962675 7962676 7962677 7962678 7962679 7962680
FMT700-P Outlet section ⑤ FMT700-P outlet section 5 x D, nominal diameter DN 25, 1 ISO KF flange, 1 clamping ring FMT700-P outlet section 5 x D, nominal diameter DN 50, 1 tapered flange, 1 clamping ring FMT700-P outlet section 5 x D, nominal diameter DN 80, 1 tapered flange, 1 clamping ring FMT700-P outlet section 5 x D, nominal diameter DN 100, 1 tapered flange, 1 clamping ring FMT700-P outlet section 5 x D, nominal diameter DN 150, 1 tapered flange, 1 clamping chain FMT700-P outlet section 5 x D, nominal diameter DN 200, 1 tapered flange, 1 clamping chain	7962681 7962682 7962683 7962684 7962685 7962686
FMT700-P Hose adapter ⑥ FMT700-P hose adapter, nominal diameter DN 25 FMT700-P hose adapter, nominal diameter DN 50 FMT700-P hose adapter, nominal diameter DN 80 FMT700-P hose adapter, nominal diameter DN 100 FMT700-P hose adapter, nominal diameter DN 150 FMT700-P hose adapter, nominal diameter DN 200	7962687 7962688 7962689 7962690 7962691 7962692
FMT700-P Tapered flange ⑩ FMT700-P tapered flange, nominal diameter DN 25 FMT700-P tapered flange, nominal diameter DN 50 FMT700-P tapered flange, nominal diameter DN 80 FMT700-P tapered flange, nominal diameter DN 100 FMT700-P tapered flange, nominal diameter DN 150 FMT700-P tapered flange, nominal diameter DN 200	7962700 7962701 7962702 7962703 7962704 7962705
FMT700-P O-Ring ⑫ FMT700-P o-ring, nominal diameter DN 25, including centering rings FMT700-P o-ring, nominal diameter DN 50 FMT700-P o-ring, 94 x 3, nominal diameter DN 80 FMT700-P o-ring, 122 x 3, nominal diameter DN 100 FMT700-P o-ring, 165 x 4, nominal diameter DN 150 FMT700-P o-ring, 217 x 5, nominal diameter DN 200	7962706 7962707 7962708 7962709 7962710 7962711
FMT700-P Intermediate flange ⑪ FMT700-P intermediate flange, nominal diameter DN 25 FMT700-P intermediate flange, nominal diameter DN 50 FMT700-P intermediate flange, nominal diameter DN 80 FMT700-P intermediate flange, nominal diameter DN 100 FMT700-P intermediate flange, nominal diameter DN 150 FMT700-P intermediate flange, nominal diameter DN 200	7962712 7962713 7962714 7962715 7962716 7962717

Accessories	Code
FMT700-P Clamping ring ⑬ FMT700-P clamping ring, nominal diameter DN 25 FMT700-P clamping ring, nominal diameter DN 50 FMT700-P clamping ring, nominal diameter DN 80 FMT700-P clamping ring, nominal diameter DN 100	7962718 7962719 7962720 7962721
FMT700-P Clamping chain ⑬ FMT700-P clamping chain, nominal diameter DN 150 FMT700-P clamping chain, nominal diameter DN 200	7962722 7962723
FMT700-P Complete flange coupling FMT700-P complete flange coupling, nominal diameter DN 25 FMT700-P complete flange coupling, nominal diameter DN 50 FMT700-P complete flange coupling, nominal diameter DN 80 FMT700-P complete flange coupling, nominal diameter DN 100 FMT700-P complete flange coupling, nominal diameter DN 150 FMT700-P complete flange coupling, nominal diameter DN 200	7962724 7962725 7962726 7962727 7962728 7962729
FMT700-P Filter cartridge FMT700-P filter cartridge, nominal diameter DN 25 FMT700-P filter cartridge, nominal diameter DN 50 FMT700-P filter cartridge, nominal diameter DN 80 FMT700-P filter cartridge, nominal diameter DN 100 FMT700-P filter cartridge, nominal diameter DN 150 FMT700-P filter cartridge, nominal diameter DN 200	7962730 7962731 7962732 7962733 7962734 7962735
FMT700-P Filter coupling flange FMT700-P filter coupling flange, nominal diameter DN 25 FMT700-P filter coupling flange, nominal diameter DN 50 FMT700-P filter coupling flange, nominal diameter DN 80 FMT700-P filter coupling flange, nominal diameter DN 100 FMT700-P filter coupling flange, nominal diameter DN 150 FMT700-P filter coupling flange, nominal diameter DN 200	7962736 7962737 7962738 7962739 7962740 7962741

Contact us

ABB Ltd.

Oldends Lane, Stonehouse
Gloucestershire, GL10 3TA
UK
Phone: +44 (0)1453 826661
Fax: +44 (0)1453 829671

ABB Inc.

125 E. County Line Road
Warminster PA 18974
USA
Phone: +1 215 674 6000
Fax: +1 215 674 7183

ABB Automation Products GmbH

Dransfelder Str. 2
37079 Goettingen
Germany
Phone: +49 551 905-534
Fax: +49 551 905-555

www.abb.com

Note

We reserve the right to make technical changes or modify the contents of this document without prior notice. With regard to purchase orders, the agreed particulars shall prevail. ABB does not accept any responsibility whatsoever for potential errors or possible lack of information in this document.

We reserve all rights in this document and in the subject matter and illustrations contained therein. Any reproduction, disclosure to third parties or utilization of its contents - in whole or in parts - is forbidden without prior written consent of ABB.

Copyright© 2010 ABB
All rights reserved