

HART



HART
COMMUNICATION PROTOCOL

ABB

Temperature Transmitter

TTX300

Interface Description

COM/TTX300/HART-EN

01.2010

Manufacturer:

ABB Automation Products GmbH

Borsigstraße 2

63755 Alzenau

Germany

Tel.: +49 551 905-534

Fax: +49 551 905-555

CCC-support.deapr@de.abb.com

Customer service center

Phone: +49 180 5 222 580

Fax: +49 621 381 931-29031

automation.service@de.abb.com

© Copyright 2010 by ABB Automation Products GmbH

Subject to changes without notice

This document is protected by copyright. It assists the user in safe and efficient operation of the device. The contents of this document, whether whole or in part, may not be copied or reproduced without prior approval by the copyright holder.

1	Introduction	4
2	Communication / HART tag / Device address	4
3	Configuration	5
3.1	Configuration types	5
3.1.1	HART communication	5
3.1.2	Configuration with the handheld terminal.....	5
3.1.3	Configuration via DTM	6
3.1.4	Configuration via EDD.....	6
3.1.5	Optional: Configuration via the LCD display with the control buttons.....	6
3.2	HART variables	6
4	Parameter description	8
4.1	Identify	8
4.2	Temperature measurement.....	8
4.3	Current output / Mapping of measuring range	10
4.4	Communication / HART.....	11
4.5	Miscellaneous.....	11
5	2-sensor input functionality / Dual sensor mode.....	12
5.1	2-HART measurement signals	12
5.2	Redundancy and sensor backup.....	12
5.3	Sensor drift monitoring	14
6	Sensor error adjustment.....	16
7	D/A analog output compensation (4 and 20 mA trim)	17
8	Special functions.....	18
8.1	Output signal simulation	18
8.2	Device reset	18
8.3	Factory reset	18

1 Introduction

These instructions describe the communication-specific properties of the TTX300-HART transmitter.

For general information concerning operation, sensor configuration, connection or explosion protection, please refer to the operating and commissioning instructions.

For commissioning purposes, you will need a device driver in EDD (Electronic Device Description) or DTM (Device Type Manager) format.

You can download the relevant EDD and DTM from www.abb.com.

The way in which individual parameters are displayed, arranged and referred to may vary between different frame applications.

2 Communication / HART tag / Device address

For ease of identification, each HART device features a configurable 8-digit HART tag. All devices are supplied with the HART tag "TI XXX" as standard.

When storing HART tags with more than 8 digits in the device, use the "Report" parameter, which supports up to 32 characters.

In addition to the HART tag, each device has a HART address.

This address is set to zero by default, which means that the device operates in HART standard communication mode (point-to-point operation). When an address in the range 1 to 15 is used, the device switches to HART multidrop mode. This operating mode enables users to connect up to 15 devices in parallel to a power supply.

In multidrop mode, an analog output signal that matches the process temperature is not available. The output signal in multidrop mode is a constant 3.6 mA and is used exclusively for the power supply.

In multidrop mode, sensor or process data information is available only as a HART signal.

3 Configuration

3.1 Configuration types

Transmitters can be configured as follows:

- Via HART protocol and handheld terminal (e.g., ABB DHH800)
- Via DTM in FDT frame applications (e.g., ABB DAT200)
- Via EDD in EDD frame applications (e.g., HCF SDC625)
- Via field bus (PROFIBUS), if the higher-level remote I/O system is HART-enabled (e.g., ABB S800 / S900)

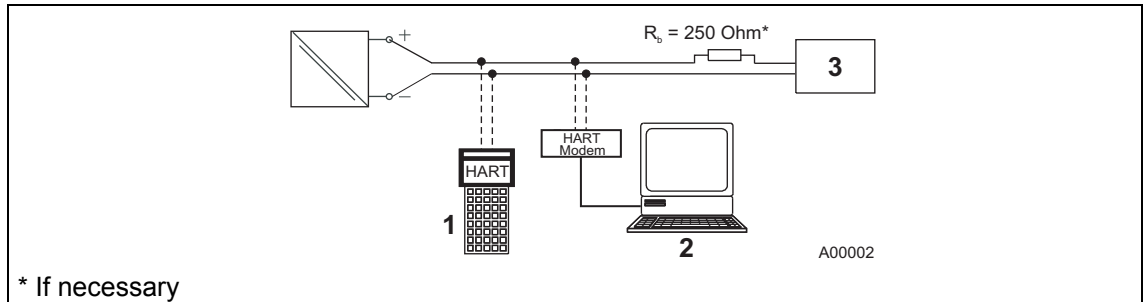

Fig. 1

- 1 Handheld terminal
- 2 FDT / DTM technology
- 3 Power unit (process interface)

3.1.1 HART communication

Communication with the transmitter takes place using the HART protocol. The communication signal is modulated onto both wires of the signal line according to the HART FSK "Physical Layer" specification, version 8.1 (08/1999). The electrical connection is provided either at the (+) and (-) terminals of the transmitter or by the power supply cable that is installed on site. This makes remote configuration possible using a power supply unit.

3.1.2 Configuration with the handheld terminal

Configuration with the handheld terminal normally takes place at the factory before the transmitter is installed in an industrial plant.

1. Open the housing of the sensor head measuring inset.
2. Carefully clamp both test tips of the separate operating control onto the contacts in the slots in front of the (+) and (-) terminals.
3. Make sure that the test terminals are securely attached.
4. Carry out installation as shown in Fig. 1.



Important

The test tips are connected without observing polarity. Clamp the test tips to the (+) and (-) terminals. The transmitter can also be configured via the HART protocol during normal operation.

3.1.3 Configuration via DTM

Configuration can be performed within an FDT frame application that is approved for use with the DTM. The bus can be connected via FSK modem as well as HART + USB, PROFIBUS + remote I/O, or HART Multiplexer.

3.1.4 Configuration via EDD

Configuration can also be performed within an EDD frame application that is approved for use with the EDD.

3.1.5 Optional: Configuration via the LCD display with the control buttons

Configuration can be performed with an LCD using the four control buttons on the front. Various submenus are available that allow you to change the configuration. For details of how to use the LCD, please refer to the description in the operating instructions.



Important

In contrast to configuration based on the DTM or EDD, the functionality of the transmitter can only be changed to a limited extent with the LCD and control buttons.

3.2 HART variables

As well as providing access to parameters and diagnostic data, a HART device has up to 4 dynamic variables, which can be read out by means of a command. Depending on the configuration, the following measurement values are available internally on the TTX300:

- Sensor 1 (temperature, resistance, voltage)
- Sensor 2 (temperature, resistance, voltage)
- Sensor 1 – sensor 2 differential (temperature, resistance, voltage)
- Sensor 2 – sensor 1 differential (temperature, resistance, voltage)
- Sensor 1 and sensor 2 redundancy (temperature, resistance, voltage)
- Average value of sensor 1 and sensor 2 (temperature, resistance, voltage)
- Electrical measurement value, sensor 1 (resistance, voltage)
- Electrical measurement value, sensor 2 (resistance, voltage)
- Electronic unit temperature (temperature)

The configuration functions in the EDD and DTM allow you to select up to 4 variables and assign them to the dynamic HART variables:

- Primary variable, PV
- Secondary variable, SV
- Tertiary variable, TV
- Quarternary variable, QV

Only the PV is mapped onto the current output, which means that it has an additional parameter in the form of the mapping range.

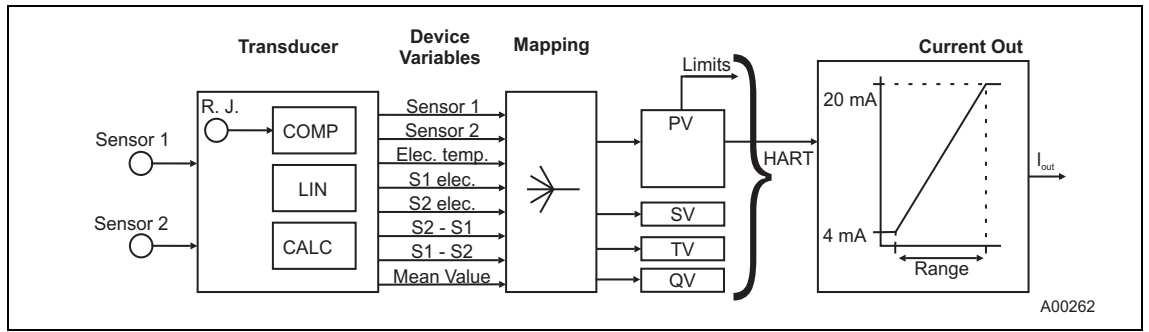

Fig. 2

This figure illustrates how the measurement value is processed from the sensor input right through to the transmitter's current output.

i

Important

If the configuration is changed (by assigning variables), you will need to check how the measurement value is subsequently processed in the higher-level control system and make any necessary adjustments.

With conventional 4 ... 20 mA operation, the PV is available indirectly via the current output. Modern remote I/O systems (such as the ABB S800 / S900) go beyond this by allowing all the subsidiary variables (SV, TV and QV) to be accessed cyclically. This means that more complex applications, whereby a measuring point has to provide more information, can be supported (e.g., absolute and differential temperature), as well as the cost-effective processing of two sensor signals with a single transmitter.

Parameter description

4 Parameter description

4.1 Identify

Parameter	Description	Safety instructions*
TAG	Measuring point name, 8 characters. The name that is selected should be unique within the system.	
Write Protection	All device parameters are write-protected. To unlock them, enter code 0110. Codes ≠ 0110 will lock the device.	Must be locked to ensure safety function.
Software Revision	Transmitter firmware version in the format XX.YY.ZZ as recommended by the NAMUR standard. This information can also be found on the transmitter's name plate.	Check that the version is correct on the basis of the data sheet or certificate.
Hardware Revision	Transmitter hardware version in the format XX.YY as recommended by the NAMUR standard. This information can also be found on the transmitter's name plate.	Check that the version is correct on the basis of the data sheet or certificate.
Manufacturer	Device manufacturer (ABB)	
Type	Device type (TTX300 series)	
Serial Number	Serial number (transmitter assembly number). This information can also be found on the transmitter's name plate.	
Description	A user-defined text (optional) that is stored in the device. This can be used to provide additional information about the measuring point, for example.	
Message	A user-defined text (optional) that is stored in the device. This can be used to provide maintenance personnel with specific information, for example.	

4.2 Temperature measurement

Parameter	Description	Safety instructions*
Measurement Mode	<p>PV measurement type. Choice depends on the type of sensor selected for sensor 1 / 2:</p> <ul style="list-style-type: none"> • Sensor 1 • Sensor 2 • Sensor 1 – sensor 2 differential • Sensor 2 – sensor 1 differential • Average of sensor 1 and sensor 2 • Sensor 1 and sensor 2 redundancy • Electr. sensor 1 (sensor input signal in Ω or mV) • Electr. sensor 2 (sensor input signal in Ω or mV) • Electronic unit temperature <p>The choice of setting determines which measured variable affects the current output (HART = "Primary variable", PV).</p>	Check safety function
Sensor 1 / 2: Sensor Type	Sensor type setting for sensor 1 / 2. All the sensors specified on the data sheet/in the manual are supported.	Check safety function

Parameter	Description	Safety instructions*
Sensor 1 / 2: Range	Physical measuring range for sensor 1 / 2, depending on type of sensor selected.	
Sensor 1 / 2: Connection	Type of sensor connection (two-wire, three-wire, or four-wire circuit). Only used for resistance sensors.	Check safety function
Sensor 1 / 2: Cold Junction Compensation	Type of reference junction: No reference No compensation (not used) Internal (internal) Internal (measured inside transmitter) External (external) Stabilized externally using a thermostat Sensor 1 Measured using a resistance thermometer on channel 1 (only configurable on channel 2)	Check safety function
Sensor 1 / 2: Temperature fixed CJ	In the case of an externally stabilized reference junction, the associated temperature is entered here in °C.	Check safety function
Sensor 1 / 2: Line Resistance	Line resistance for sensor 1 / 2 if a resistance thermometer is being used or if the sensor type selected is linear resistance measurement with a two-wire circuit.	Check safety function
CvD Dataset 1 ... 5	Callendar-Van Dusen data set 1 / 2. Coefficients R0, A, B, C	Check safety function
Fixed Point 1 ... 5	User-specific characteristic involving 32 pairs of reference points (X1..32, Y1..32), strictly monotonic increasing or decreasing.	Check safety function
Firmware version 01.01.03 and higher		
Drift Monitoring active	Activates sensor drift monitoring	Check safety function
Max Sensor Difference	Value at which sensor drift is signaled, if overshoot lasts longer than the limit time period	Check safety function
Limit / Inhibit Time	Time period that has to elapse while the max. sensor differential is being overshoot, before sensor drift is signaled	Check safety function

Parameter description

4.3 Current output / Mapping of measuring range

Parameter	Description	Safety instructions*
Unit	For selecting the unit that is to be used for the PV measurement value (°C, °F, °R, K, user, mV, Ω, mA). This setting also determines dependent parameters such as sensor limit values.	Check safety function
Range Start	Defines the lower range limit value for the sensor (corresponds to 4 mA).	Check safety function
Range End	Defines the upper range limit value for the sensor (corresponds to 20 mA).	Check safety function
Damping	Damping of the primary variable using a first-order filter element.	Check safety function
HI_HI Limit	Diagnostics are triggered if the value of the primary variable (PV) exceeds this limit value.	
HI Limit	Diagnostics are triggered if the value of the primary variable (PV) exceeds this limit value. The bit set within the diagnostics data remains set even if the HI_HI limit is overshoot.	
LO Limit	Diagnostics are triggered if the value of the primary variable (PV) drops below this limit value. The bit set within the diagnostics data remains set even if the LO_LO limit is undershot.	
LO_LO Limit	Diagnostics are triggered if the value of the primary variable (PV) drops below this limit value.	
Reaction on Failure	<p>Overrange Generates a high alarm signal when sensor or device errors occur; can be configured from 20.0 ... 23.6 mA.</p> <p>Underrange Generates a low alarm signal when sensor or device errors occur; can be configured from 3.5 ... 4.0 mA</p>	Check safety function
Firmware version 01.01.03 and higher		
Reaction on Maintenance required	<p>Analog alarm pulse signaling with configurable pulse width when sensor maintenance is required (e.g., failure of a sensor in redundancy mode or overshoot of max. sensor drift differential).</p> <ul style="list-style-type: none"> • Off • Pulse width: >0 ... 59.5 s • continuous 	Check safety function

The primary variable (PV) is mapped onto the current output in a linear fashion and within the range of 4 ... 20 mA. The mapping limits should be selected according to the application concerned and do not have to lie completely within the sensor's physical measuring range. It is also possible to assign warning and alarm limits to the PV. These are relevant from the point of diagnostics, but will not affect the current output in any way.

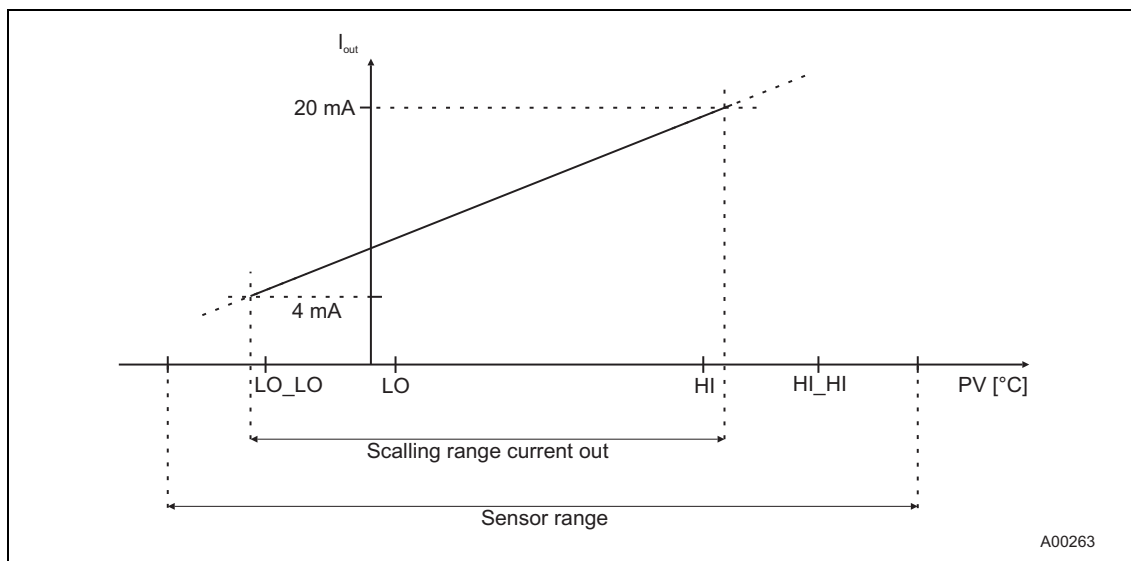

Fig. 3

4.4 Communication / HART

Parameter	Description	Safety instructions*
HART tag	Defines the HART tag name. 8 characters, alphanumeric.	
Address (Multidrop)	Specifies the communication type. Address = 0 corresponds to HART operating mode: Point-to-point communication, 4 ... 20 mA output signal address = 1 ... 15 conforms to HART multidrop operating mode output signal const. 3.6 mA only the digital HART readings are available.	Check safety function

4.5 Miscellaneous

Parameter	Description	Safety instructions*
Factory Reset	Configuration data is reset to factory settings for Pt100 three-wire circuit, 0 ... 100 °C damping off, override, adjustment data (trim high/low and DAC adjustment values are reset to factory settings).	Safety function for potential risk: All configuration and adjustment data are reset to the factory default
Reset / Warmstart	The device performs a restart (= warm start). Parameters and configuration data remain unchanged.	

* Safety check is performed acc. to SIL safety information based on the document SM/TTX3X0/SIL

5 2-sensor input functionality / Dual sensor mode

5.1 2-HART measurement signals

As explained in the "Electrical connections" section, equivalent resistance sensors or thermocouple sensors (or a combination of the two) can be connected to the transmitter inputs.

Remote I/O systems such as the ABB S900 read out these HART variables on a cyclic basis and provide them to the control system in the form of cyclic process data.

The 4 ... 20 mA analog output maps one sensor value only. Users can choose to map sensor value 1 or sensor value 2, the differential based on both, or the average. The value that is to be mapped is specified during transmitter configuration, e.g., LCD in the menu "Config. Device" / submenu "Input/output Assignment".

5.2 Redundancy and sensor backup

Use two sensors and sensor redundancy mode to increase system uptime.

If sensor 1 fails, the output signal switches bumplessly within the cyclic refresh rate to sensor 2.

In addition, a HART diagnostic message is generated in accordance with Namur NE107 "Maintenance required / Sensor wire break".

If redundant sensor 2 fails, a HART signal diagnostic notification is generated.

To minimize the effect on the output signal and increase accuracy in case of a sensor wire break, the average of both sensors is mapped to the analog output in redundancy mode as long as both sensors are available.

Sensor or device failure fault signaling at the analog output signal as required by Namur NE43 / NE107 ensures that the transmitter is capable of signaling "Maintenance required" diagnostic information via both a HART signal and an analog signal, using overranging (22 mA) and underranging (3.6 mA).

"Maintenance required" diagnostic information can be signaled in accordance with NE107 during normal operation with a 4 ... 20 mA analog output by superimposing pulses.

Depending on fault signaling, positive 22 mA pulses are superimposed on the 4 ... 20 mA signal in the case of a 22 mA overrange configuration and negative 3.6 mA pulses are imposed in the case of a 3.6 mA underrange configuration.

The following values can be configured via pulse width parameters:

- A pulse width of 0.5 ... 59.5 s (increment 0.5 s)
- Continuous pulse
- No diagnostic signaling per pulse on the analog output

The specified pulse width refresh rate is 60 seconds.

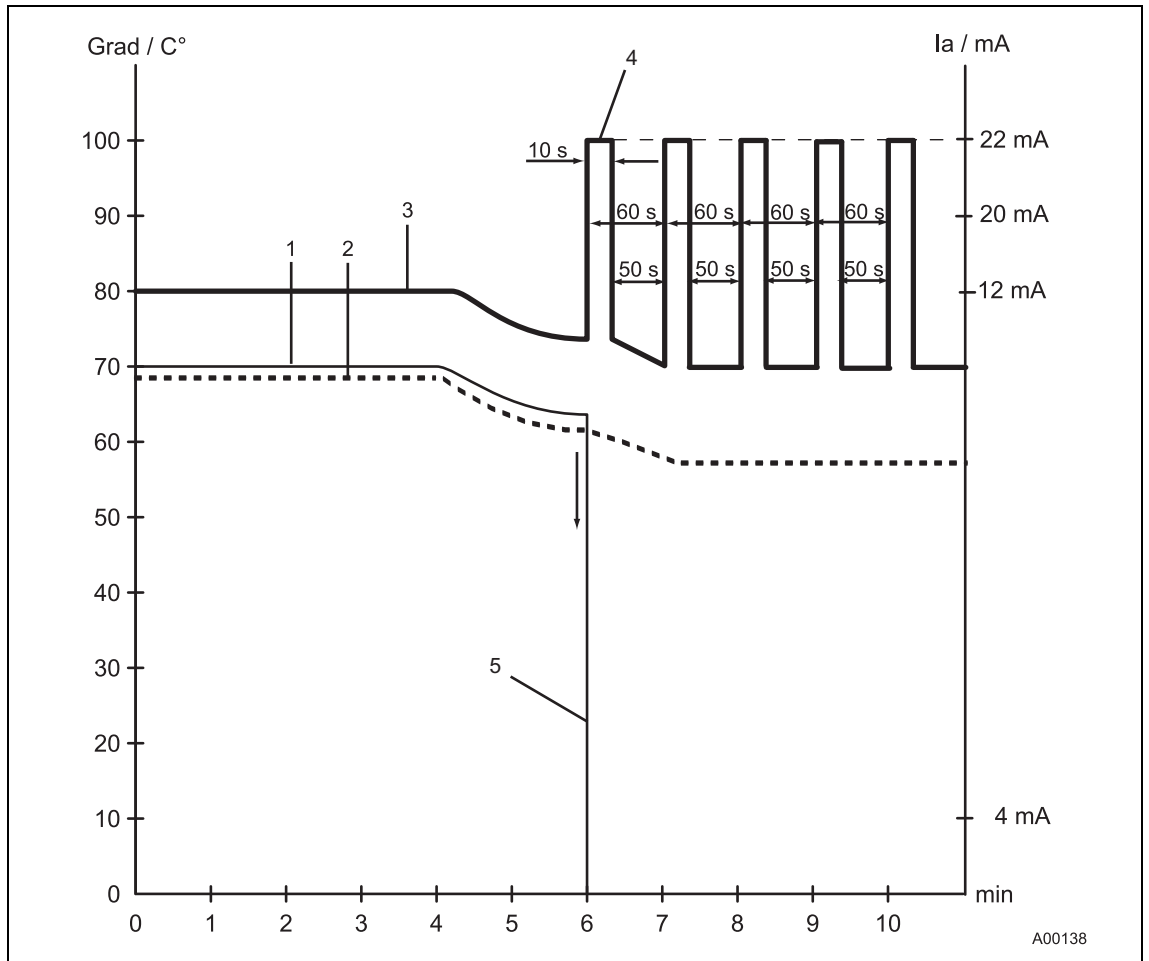

Fig. 4: Alarm pulse signaling in redundancy mode for failure of the temperature characteristic for sensor 2

- | | |
|--|---|
| <p>1 Temperature characteristic for sensor 1 -----</p> <p>2 Temperature characteristic for sensor 2 ———</p> <p>3 4 ... 20 mA output signal</p> | <p>4 Alarm pulse:</p> <ul style="list-style-type: none"> • Off • On -> Configurable pulse width • Continuous pulse <p>5 Wire break temperature characteristic 2</p> |
|--|---|

Example:

If a pulse width of 10 seconds is set, the normal temperature signal of 4 ... 20 mA is found at the output due to the pulse width refresh rate of 60 seconds after a 10-second pulse diagnostic alarm signal, e.g., of 22 mA for 50 seconds.

The next cycle begins with a 10-second diagnostic alarm signal and subsequently starts again with a 50-second pulse width refresh rate with the normal 4 ... 20 mA temperature signal.

5.3 Sensor drift monitoring

When two sensors are connected, an optional sensor drift monitoring function can be activated in redundancy mode, in 2-HART measurement signal mode and during averaging.

Sensor drift monitoring and analog diagnostic signaling (described in the previous section) can only be activated and configured using a TTX300 DTM file or EDD-based tools.

Sensor drift monitoring can be activated with the following 2 sensor types:

- 2 x resistance thermometers (RTD), two-wire circuit
- 2 x resistance thermometers (RTD), three-wire circuit
- 2 x resistors (potentiometers), two-wire circuit
- 2 x resistors (potentiometers), three-wire circuit
- 2 x thermocouples
- 2 x voltages
- 1 x resistance thermometer (RTD), two-wire circuit and 1x thermocouple
- 1 x resistance thermometer (RTD), three-wire circuit and 1x thermocouple
- 1 x resistance thermometer (RTD), four-wire circuit and 1x thermocouple

To activate sensor drift monitoring, the transmitter must first be configured for the sensor types referred to above. Following this, the maximum permissible sensor deviation must be configured, e.g., max. 1 K.

Since sensor response times may be marginally different, it is then necessary to set a limit time period during which the sensor deviation must be continuously larger than the maximum sensor drift differential value defined previously (1°K, for example).

If the transmitter records a larger sensor deviation during the defined time period, a "Maintenance required" HART diagnostic message is generated according to NE107. In addition, the device status "M" is displayed below the measurement value on the LCD, along with the diagnostic error code, to indicate that the "Maintenance required" message has been output.

"Maintenance required" diagnostic information concerning sensor drift monitoring can also be superimposed on the 4 ... 20 mA signal as a pulse alarm signal and signaled in the same way as if a sensor failure had occurred in redundancy mode (for a detailed description, see the section on redundancy).

If drift monitoring is used for equivalent sensors (2 x Pt100 or 2 x thermocouples), the mean value calculated from the two sensors is mapped onto the transmitter's output signal as a process variable in redundancy mode.

If a thermocouple is used for Pt100 drift monitoring, the Pt100 sensor must be connected to channel 1 and the thermocouple to channel 2.

The reading from channel 1 (Pt100) is mapped to the transmitter output as a process variable.



Note

Before configuring the maximum permissible sensor deviation for drift detection, you are recommended to align sensor channel 2 with the value of sensor channel 1.

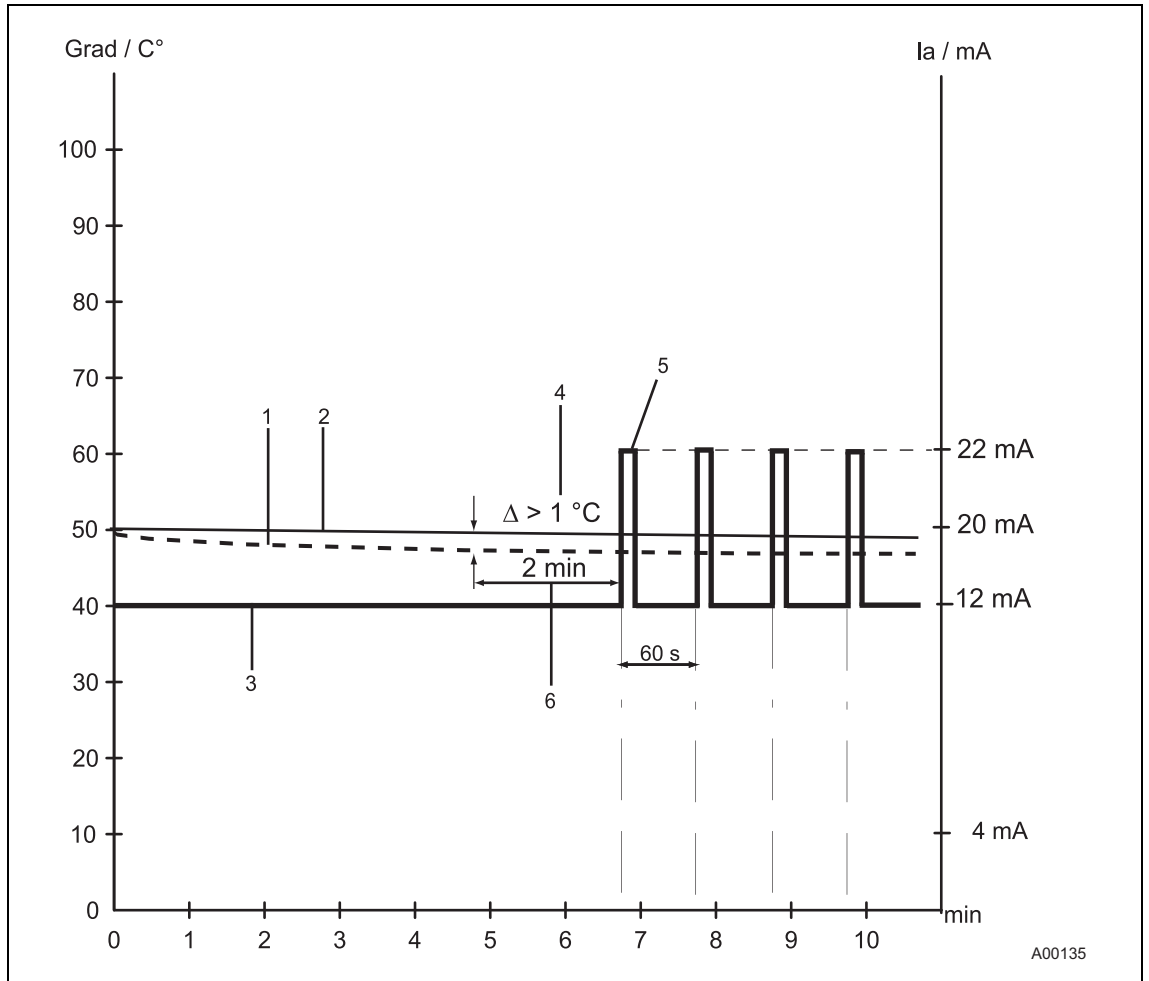

Fig. 5: Alarm pulse signaling during sensor drift overshoot

- | | |
|---|---|
| <p>1 Temperature characteristic for sensor 1 -----</p> <p>2 Temperature characteristic for sensor 2 ———</p> <p>3 4 ... 20 mA output signal</p> <p>4 Maximum sensor drift differential (e.g., $\Delta > 1 \text{ }^\circ\text{C}$)</p> | <p>5 Alarm pulse:</p> <ul style="list-style-type: none"> • Off • On -> Configurable pulse width • Continuous pulse <p>6 Sensor drift monitoring time period (e.g., 2 min)</p> |
|---|---|

6 Sensor error adjustment

For sensor error adjustment, the sensor connected to the transmitter must be brought to the lower range limit value temperature / Trim low using a water quench or oven. It is important to make sure the temperature is balanced and stable.

In the DTM, check that the proper adjustment temperature has been entered for the sensor before adjusting it.

Based on the comparison of the adjustment temperature entered (setpoints) with the digital temperature measured by the transmitter, the transmitter calculates the temperature deviation resulting from the sensor error.

During single-point adjustment, this calculated temperature deviation results in an offset shift of the linear characteristic output by the linearization module.

Sensor error two-point adjustment results in a change to the offset and gradient due to the linear temperature value characteristic output by the linearization module.

A pure sensor offset error must be corrected using the "Trim low" calibration function. By contrast, if the error is not a pure sensor offset error, it can only be corrected using two-point adjustment or two-point calibration.

7 D/A analog output compensation (4 and 20 mA trim)

Output compensation is used to compensate for errors in the current input of the higher-level system.

Analog output compensation for the transmitter can be used to modify the loop current so that the desired value is displayed in the higher-level system.

Error compensation for the higher-level system is possible at the lower range limit value with 4 mA and / or 20 mA (single-point error correction: offset; two-point error correction: offset + linear gradient).

D/A analog output compensation can be accessed in the TTX300 DTM via the path <Device> <Calibration> <Output Compensation>.

Prior to analog compensation, it is necessary to determine the loop current values based on iterative entry of current values in simulation mode; the higher-level I/O system displays exactly 4.000 mA or the lower range limit temperature, and 20.000 mA or the upper range limit temperature. The current loop values must be measured using an ammeter and recorded.

The lower range limit value or 4.000 mA +/- 16 μ A must then be simulated in D/A analog output compensation mode using sensor simulation. Following this, the iteratively calculated current value at which the higher-level system displays exactly 4.000 mA or the lower range limit value must be entered as a compensation value. Proceed in a similar manner for the upper range limit value or 20.000 mA.

The disadvantage of D/A analog output compensation is that the HART signal present without correction prior to D/A conversion differs from the analog output signal after D/A conversion due to the incoming error correction of the higher-level system.

8 Special functions

8.1 Output signal simulation

When output signal simulation mode is activated in the TTX300's DTM via the path <Device> <Simulation> <Simulation>, an output signal in the range of 3.5 ... 23.6 mA can be simulated, regardless of the sensor value.

8.2 Device reset

In the DTM, a device restart can be triggered via the path <Device> <Tools> <Device Reset>. The type of reset that follows is comparable with switching the supply voltage off and on again.

8.3 Factory reset

Via the DTM path <Device> <Tools> <Reset to Factory Setting>, the TTX300 configuration data can be reset to the factory settings (Pt100, three-wire circuit, 0 ... 100 °C, damping off, and override).



Important

The adjustment data (Trim high / low) and D/A compensation values are also reset to their factory settings.

ABB has Sales & Customer Support expertise in over 100 countries worldwide.

www.abb.com/temperature

The Company's policy is one of continuous product improvement and the right is reserved to modify the information contained herein without notice.

Printed in the Fed. Rep. of Germany (01.2010)

© ABB 2010

3KXT200004R4001



ABB Limited

Salterbeck Trading Estate
Workington, Cumbria
CA14 5DS
UK
Tel: +44 (0)1946 830 611
Fax: +44 (0)1946 832 661

ABB Inc.

125 E. County Line Road
Warminster, PA 18974
USA
Tel: +1 215 674 6000
Fax: +1 215 674 7183

ABB Automation Products GmbH

Borsigstr. 2
63755 Alzenau
Germany
Tel: +49 551 905-534
Fax: +49 551 905-555
CCC-support.deapr@de.abb.com

COM/TTX300/HART-EN