

Models 261GS/GC/GG/GJ/GM/GN/GR
Models 261AS/AC/AG/AJ/AM/AN/AR
Pressure Transmitter



Models 261GS/GC/GG/GJ/GM/GN/GR
Models 261AS/AC/AG/AJ/AM/AN/AR

Operating Instruction
IM/261Gx/Ax-EN

Rev. 06
Issue date: 08.2011

Translation of the original instruction

Manufacturer

ABB Automation Products GmbH
Process Automation

Schillerstr. 72
32425 Minden
Germany
Tel: +49 551 905-534
Fax: +49 551 905-555

Customer service center

Phone: +49 (0) 180 5 222 580
Fax: +49 (0) 621 381 931-29031
automation.service@de.abb.com

© Copyright 2011 by ABB

Subject to changes without notice

This document is protected by copyright. It assists the user in safe and efficient operation of the device. The contents of this document, whether whole or in part, may not be copied or reproduced without prior approval by the copyright holder.

Contents

1	Safety.....	5			
1.1	General information and notes for the reader.....	5			
1.2	Intended use.....	5			
1.3	Improper use	5			
1.4	Target groups and qualifications	5			
1.5	Warranty provisions	5			
1.6	Plates and symbols.....	6			
1.6.1	Safety / warning symbols, note symbols	6			
1.7	Name plate.....	7			
1.7.1	Compliance with Pressure Equipment Directive (97/23/EC).....	8			
1.8	Transport safety instructions	8			
1.9	Storage conditions.....	8			
1.10	Safety instructions for electrical installation.....	8			
1.11	Safety instructions for operation.....	8			
1.12	Returning devices	8			
1.13	Integrated management system.....	9			
1.14	Disposal	9			
1.14.1	Information on WEEE Directive 2002/96/EC (Waste Electrical and Electronic Equipment).....	9			
1.14.2	RoHS Directive 2002/95/EC	9			
2	Use in potentially explosive atmospheres	10			
2.1	Explosion protection	10			
2.2	Type-examination certificate/Declaration of conformity	10			
2.3	Type of protection "intrinsic safety Ex i"	10			
2.4	Use in areas with combustible dust.....	10			
2.5	Category 3 (EPL Gc) with type of protection "nA".....	10			
2.6	Use of handheld terminal / PC	10			
3	Function and System Design.....	11			
3.1	Principle of operation and construction	11			
4	Mounting	13			
4.1	Pressure transmitter.....	13			
4.2	Sealing and screw connections.....	14			
4.3	Moisture	14			
4.4	Measuring pipe	15			
5	Electrical connections.....	16			
5.1	Cable connection.....	16			
5.2	Electrical connection in the cable connection area	17			
5.3	Electrical connection with plug.....	18			
5.3.1	Assembly and connection of Han 8D (8U) socket connector	19			
5.4	Protective conductor/Grounding (optional)	19			
5.5	Communication setup.....	19			
5.6	Connecting cable.....	20			
6	Commissioning.....	21			
6.1	General remarks	21			
6.2	Output signal	21			
6.3	Write protection	21			
6.4	Adjusting lower range value / oblique sensor.....	22			
6.5	Installing/Removing the LCD indicator.....	23			
6.6	Pressure sensor ventilation	24			
7	Configuration, parameterization.....	25			
7.1.1	Standard configuration	25			
7.2	Configuration types.....	25			
7.3	Configuration using pushbutton on pressure transmitter	25			
7.3.1	General remarks	25			
7.3.2	Configuration	25			
7.4	Configuration with the LCD indicator	26			
7.4.1	Menu navigation	26			
7.4.2	Process display	27			
7.4.3	Switching to the configuration level (parameterization)	27			
7.4.4	Menu structure	28			
7.4.5	Parameter descriptions.....	29			
7.5	Configuration with the PC/laptop or handheld terminal	32			
7.6	Configuration with the graphical user interface (DTM)	33			
7.6.1	System requirements.....	33			
7.7	Parameter descriptions.....	33			
8	Ex relevant specifications.....	35			
8.1	Hazardous atmospheres.....	35			
8.1.1	ATEX transmitter with type of protection "intrinsic safety Ex ia/ib" in accordance with Directive 94/9/EC	35			
8.1.2	IECEx transmitter with the following types of protection: "intrinsic safety ia", "non sparking nA" and "dust ignition protection by enclosure tb"	35			
8.1.3	Factory Mutual (FM).....	36			
8.1.4	Canadian Standards Association (CSA).....	36			
8.1.5	NEPSI (China).....	36			
9	Technical Data	37			
9.1	Functional specifications.....	37			
9.1.1	Measuring range limits and span limits	37			
9.1.2	Span limits.....	37			
9.1.3	Zero suppression and elevation	37			
9.1.4	Damping.....	37			
9.1.5	Warm-up time	37			
9.1.6	Insulation resistance	37			
9.2	Operating limits.....	38			
9.2.1	Pressure limits	38			
9.2.2	Temperature limits °C (°F)	38			
9.2.3	Limits for environmental effects.....	38			
9.3	Measuring accuracy	39			
9.3.1	Reference conditions according to IEC 60770 ...	39			
9.3.2	Dynamic response (according to IEC 61298-1) ..	39			
9.3.3	Measuring error for setting cut-off point	39			
9.3.4	Ambient temperature	39			
9.3.5	Temperature coefficient (T _K).....	39			

9.3.6	Power supply.....	39
9.3.7	Load.....	39
9.3.8	Electromagnetic fields.....	40
9.3.9	Mounting position.....	40
9.3.10	Long-term stability.....	40
9.3.11	Vibration effect.....	40
9.3.12	Total performance.....	40
9.4	Technical specification.....	41
9.4.1	Materials.....	41
9.4.2	Calibration.....	41
9.4.3	Optional extras.....	41
9.4.4	Process connections.....	41
9.4.5	Electrical connections.....	42
9.4.6	Weight.....	42
9.4.7	Packaging.....	42
9.5	Mounting dimensions.....	43
9.5.1	Standard version.....	43
9.5.2	Version with the options “LCD indicator” and “Harting Han plug”.....	44
9.5.3	Transmitter with flush diaphragm.....	45
9.5.4	Version with ball valve connection.....	46
9.5.5	Mounting with angle bracket (optional).....	47
10	Maintenance / Repair.....	48
10.1	Removal.....	48
11	Appendix.....	49
11.1	Approvals and certifications.....	49

1 Safety

1.1 General information and notes for the reader

You must read these instructions carefully prior to installing and commissioning the device.

These instructions are an important part of the product and must be kept for future reference.

These instructions are intended as an overview and do not contain detailed information on all designs for this product or every possible aspect of installation, operation and maintenance.

For additional information or if specific problems occur that are not discussed in these instructions, contact the manufacturer.

The content of these instructions is neither part of any previous or existing agreement, promise or legal relationship nor is it intended to change the same.

This product is built based on state-of-the-art technology and is operationally safe. It has been tested and left the factory in perfect working order from a safety perspective. The information in the manual must be observed and followed in order to maintain this state throughout the period of operation.

Modifications and repairs to the product may only be performed if expressly permitted by these instructions.

Only by observing all of the safety instructions and all safety / warning symbols in these instructions can optimum protection of both personnel and the environment, as well as safe and fault-free operation of the device, be ensured.

Information and symbols directly on the product must be observed. They may not be removed and must be fully legible at all times.

1.2 Intended use

261A pressure transmitters measure absolute pressure and 261G pressure transmitters gauge pressure or the level of gases, vapors and liquids.

For information on measuring ranges and permissible overload, refer to the section "Specifications".

Using these products as intended involves observing the following points:

- Read and follow the instructions in this manual.
- Observe the technical limit values (refer to the section "Specifications").
- Use only approved liquids for measurement (refer to the section "Permissible measuring agents").

1.3 Improper use

The following are considered to be instances of improper use of the device:

- As a climbing aid, e.g., for mounting purposes.
- As a support for external loads, e.g., as a support for piping, etc.
- Adding material, e.g., by painting over the name plate or welding/soldering on parts.
- Removing material, e.g., by spot drilling the housing.

1.4 Target groups and qualifications

Installation, commissioning and maintenance of the product may only be performed by trained specialist personnel who have been authorized by the plant operator to do so. The specialist personnel must have read and understood the manual and comply with its instructions.

The operators must strictly observe the applicable national regulations with regards to installation, function tests, repairs, and maintenance of electrical products.

1.5 Warranty provisions

Using the device in a manner that does not fall within the scope of its intended use, disregarding this manual, using underqualified personnel, or making unauthorized alterations releases the manufacturer from liability for any resulting damage. This renders the manufacturer's warranty null and void.

1.6 Plates and symbols

1.6.1 Safety / warning symbols, note symbols



DANGER – Serious damage to health / risk to life!

This symbol in conjunction with the signal word “Danger” indicates an imminent danger. Failure to observe this safety information will result in death or severe injury.



DANGER – Serious damage to health / risk to life!

This symbol in conjunction with the signal word “Danger” indicates an imminent electrical hazard. Failure to observe this safety information will result in death or severe injury.



WARNING – Body injury!

This symbol in conjunction with the signal word “Warning” indicates a possibly dangerous situation. Failure to observe this safety information may result in death or severe injury.



WARNING – Body injury!

This symbol in conjunction with the signal word “Warning” indicates a potential electrical hazard. Failure to observe this safety information may result in death or severe injury.



CAUTION – Minor injury!

This symbol in conjunction with the signal word “Caution” indicates a possibly dangerous situation. Failure to observe this safety information may result in minor or moderate injury. This may also be used for property damage warnings.



ATTENTION – Property damage!

The symbol indicates a potentially damaging situation. Failure to observe this safety information may result in damage to or destruction of the product and / or other system components.



IMPORTANT (NOTE)

This symbol indicates operator tips, particularly useful information, or important information about the product or its further uses. It does not indicate a dangerous or damaging situation.

1.7 Name plate

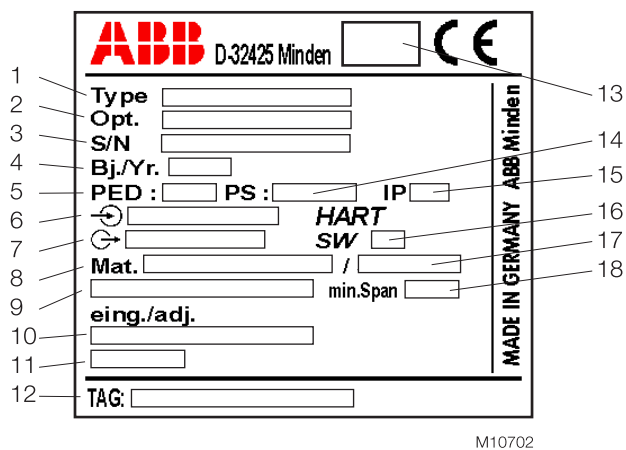

Fig. 1: Name plate for pressure transmitter model 261xx

- 1 Device type / Order code |
- 2 Options – additional information on the order code |
- 3 Device serial number (factory no.) | 4 Year of manufacture |
- 5 Identification code with reference to the Pressure Equipment Directive (SEP or 1 G) | 6 Power supply | 7 Output signal |
- 8 Materials that come into contact with the medium |
- 9 Measuring range lower limit to measuring range upper limit (LRL to URL) | 10 Measuring range, set to ... |
- 11 HART output (process variable) |
- 12 Measuring point tag (max. 32 characters) |
- 13 "SIL2" identification code (optional) | 14 Permissible pressure |
- 15 Degree of protection | 16 Software version |
- 17 Filling fluid, if present | 18 Minimum measuring span

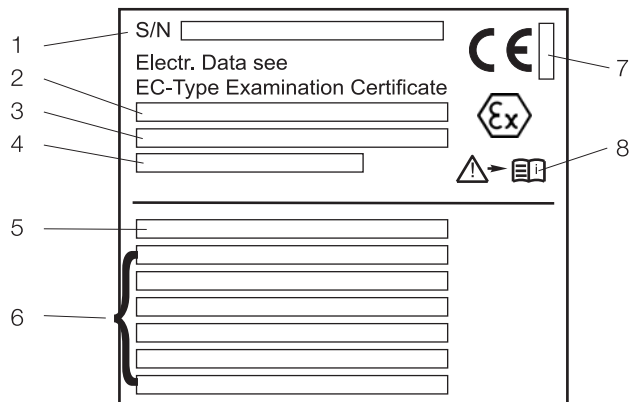

Fig. 2: Additional name plate for devices intended for use in explosion risk areas or for devices with direct mount or remote seals (optional)

- 1 Serial number (factory no.) | 2 Type of protection |
- 3 Type of protection (continued) |
- 4 Number of the EC-type-examination certificate |
- 5 Order code for direct mount seal |
- 6 Type of seal, nominal diameter, max. pressure, temperature limits, sealing surface, material, filling fluid |
- 7 Identification number of the notified body according to ATEX (optional) |
- 8 Symbol: "Notice". Observe the specifications in the operating instructions and type-examination certificate.

i IMPORTANT (NOTE)

For information on the individual letters/numbers that make up the order code, please refer to the order confirmation or associated data sheet.

For information about labeling in accordance with the Pressure Equipment Directive, please observe the information in "Compliance with Pressure Equipment Directive".

1.7.1 Compliance with Pressure Equipment Directive (97/23/EC)

Devices with PS > 200 bar (20 MPa)

Devices with a permissible pressure of PS > 200 bar (20 MPa) have been tested for conformity by the Technical Supervisory Association TÜV NORD (0045) in accordance with module H and can be used for fluids of group 1 (PED: 1G).

The name plate bears the following identification codes:



M10704

Fig. 3: Identification codes according to Pressure Equipment Directive (example)

1 PED: 1G | 2 Identification number of the notified body according to the Pressure Equipment Directive | 3 "SIL 2" identification code (optional)

Devices with PS ≤ 200 bar (20 MPa)

Devices with a permissible pressure PS ≤ 200 bar (20 MPa) conform to sec. 3 para. (3) and have not been tested for conformity. The devices have been constructed and manufactured according to sound engineering practice (SEP). The CE marking on the device does not refer to the Pressure Equipment Directive.

The name plate then contains the following identification codes: PED: SEP.

1.8 Transport safety instructions

Observe the following instructions:

- Do not expose the device to moisture during transport. Pack the device accordingly.
- Pack the device so that it is protected against vibrations during transport, e.g., by using air-cushioned packaging.

Prior to installation, check the devices for possible damage that may have occurred as a result of improper transport. Details of any damage that has occurred in transit must be recorded on the transport documents. All claims for damages must be submitted to the shipper without delay and before installation.

1.9 Storage conditions

- The device must be stored in dry and dust-free conditions. Always keep the device in its original package during storage / transport.
- Observe the permissible ambient conditions for transport and storage according to the section "Specifications".
- In principle, the devices may be stored for an unlimited period. However, the warranty conditions stipulated in the order confirmation of the supplier apply.

1.10 Safety instructions for electrical installation

The electrical connection may only be established by authorized specialist personnel and in accordance with the connection diagrams.

The electrical connection information in the manual must be observed; otherwise, the type of electrical protection may be adversely affected.

Ground the measurement system according to requirements.

1.11 Safety instructions for operation

Before switching on the device, make sure that your installation complies with the environmental conditions listed in the chapter "Specifications" or on the data sheet.

If there is a chance that safe operation is no longer possible, take the device out of operation and secure it against unintended startup.

1.12 Returning devices

Use the original packaging or a secure transport container of an appropriate type if you need to return the device for repair or recalibration purposes. Fill out the return form (see the Appendix) and include this with the device.

According to the EU Directive governing hazardous materials, the owner of hazardous waste is responsible for its disposal or must observe the following regulations for shipping purposes: All devices delivered to ABB Automation Products GmbH must be free from any hazardous materials (acids, alkalis, solvents, etc.).

Please contact Customer Center Service acc. to page 2 for nearest service location.

1.13 Integrated management system

ABB Automation Products GmbH operates an integrated management system, consisting of:

- Quality management system to ISO 9001:2008
- Environmental management system to ISO 14001:2004
- Occupational health and safety management system to BS OHSAS 18001:2007 and
- Data and information protection management system

Environmental awareness is an important part of our company policy.

Our products and solutions are intended to have minimum impact on the environment and on people during manufacturing, storage, transport, use, and disposal.

This includes the environmentally-friendly use of natural resources. We conduct an open dialog with the public through our publications.

1.14 Disposal

This product is manufactured from materials that can be recycled by specialist recycling companies.

1.14.1 Information on WEEE Directive 2002/96/EC (Waste Electrical and Electronic Equipment)

This product is not subject to WEEE Directive 2002/96/EC or relevant national laws (e.g., ElektroG in Germany).

The product must be disposed of at a specialist recycling facility. Do not use municipal garbage collection points. According to the WEEE Directive 2002/96/EC, only products used in private applications may be disposed of at municipal garbage collection points. Proper disposal prevents negative effects on people and the environment, and supports the reuse of valuable raw materials.

If it is not possible to dispose of old equipment properly, ABB Service can accept and dispose of returns for a fee.

1.14.2 RoHS Directive 2002/95/EC

With the Electrical and Electronic Equipment Act (ElektroG) in Germany, the European Directives 2002/96/EC (WEEE) and 2002/95/EC (RoHS) are translated into national law. ElektroG defines the products that are subject to regulated collection and disposal or reuse in the event of disposal or at the end of their service life. ElektroG also prohibits the marketing of electrical and electronic equipment that contains certain amounts of lead, cadmium, mercury, hexavalent chromium, polybrominated biphenyls (PBB), and polybrominated diphenyl ethers (PBDE) (also known as hazardous substances with restricted uses).

The products provided by ABB Automation Products GmbH do not fall within the current scope of regulations on hazardous substances with restricted uses or the directive on waste electrical and electronic equipment according to ElektroG. If the necessary components are available on the market at the right time, in the future these substances will no longer be used in new product development.

2 Use in potentially explosive atmospheres

2.1 Explosion protection

The device complies with the explosion-protection requirements of Directive 94/9/EC (ATEX).

When installing explosion-proof transmitters (e.g., electrical connection, ground/PE, etc.), observe national regulations, DIN/VDE standards and explosion-protection directives.

The certified explosion-proof designation for the transmitter is provided on the name plate.

2.2 Type-examination certificate/Declaration of conformity

For explosion-proof models, the EC-type-examination certificate or declaration of conformity is included with these operating instructions.

2.3 Type of protection "intrinsic safety Ex i"

Only intrinsically safe devices may be installed in the transmitter signal circuit. The signal circuit can be interrupted while the transmitter is in operation (e.g., clamping/unclamping signal lines).

The housing may be opened during operation.

Transmitters with and without remote seals and featuring type of protection "intrinsic safety Ex i" may be directly integrated into the partition separating Zone 0 and Zone 1 (sensor diaphragm in Zone 0, transmitter in Zone1), provided that the power is supplied via an intrinsically safe circuit with type of protection "Ex ia".

2.4 Use in areas with combustible dust

Installation must be performed in accordance with EN 61241-14:2004.

Transmitters can only be connected using cable glands certified in accordance with Directive 94/9/EC (ATEX). The cable gland must conform to IP 67 degree of protection. The smoldering temperature of the dust must be at least 75 K above the maximum surface temperature of the transmitter. The maximum surface temperature is 95 °C (203 °F) and is obtained by adding together the maximum ambient temperature (85 °C (185 °F)) and the maximum self-heating (10 K).



WARNING! Risk of explosion!

When using remote seals with an anti-stick coating, be aware of the risk of electrostatic discharge (with consideration given to the filling material and transport speed).

2.5 Category 3 (EPL Gc) with type of protection "nA"

The transmitter must be connected using a certified cable gland (not included in scope of delivery). The cable gland must satisfy the requirements of type of protection "increased safety Ex e" in accordance with Directive 94/9/EC (ATEX).

Additionally, the conditions stipulated in the type-examination certificate for the cable gland must be observed.



WARNING! Risk of explosion!

Opening the housing during operation (with the supply voltage switched on) is not permitted.

Opening the cover presents a risk of spark formation and, therefore, explosion.

Only open the housing when the supply voltage is switched off.

2.6 Use of handheld terminal / PC

If a handheld terminal or a PC is being used for communication / configuration / parameterization in a potentially explosive atmosphere with type of protection "intrinsic safety", the devices used must be certified accordingly.

This applies even if the device is only connected for a short period of time. This proof of "intrinsic safety" must be supplied in addition to the transmitter.



WARNING! Risk of explosion!

The handheld terminal battery must not be replaced in a potentially explosive atmosphere.

Replacing the battery presents a risk of spark formation and, therefore, explosion.

The battery may only be replaced outside of the potentially explosive atmosphere.

3 Function and System Design

Digital pressure transmitters are communication-ready field devices with microprocessor-controlled electronics. For bidirectional communication, an FSK signal is superimposed on the 4 ... 20 mA output signal via the HART protocol.

The graphic user interface (DTM) can be used to configure, poll, and test the pressure transmitter on a PC. Handheld terminals also support communication.

For "local" operation, a button is available on the system electronics for setting the lower and upper range values. In combination with an optionally installed LCD indicator, a complete external configuration and parameter setting of the transmitter can be performed via the four local pushbutton controls.

The sturdy electronics housing is made of stainless steel and is resistant to aggressive atmospheres. The process connection is also made of stainless steel or Hastelloy C. The name plate contains information about the specific pressure transmitter version (see section "Safety / Name plates").



IMPORTANT (NOTE)

For explosion-proof transmitters, the explosion protection type and, in case of attached pressure sensors, the corresponding pressure sensor type is specified on a separate plate.

In addition, a tag indicating the measuring points may be attached (as an option).

3.1 Principle of operation and construction

The transmitter has a compact design and comprises the pressure measuring cell and electronic unit with pushbutton control. Depending on the measuring range and measured variable, either a ceramic pressure sensor or a silicon pressure sensor is used.

Ceramic pressure sensor

In case of ceramic pressure sensors, the applied process pressure (pe/pabs) is transferred directly to the measuring diaphragm. Even a very slight deflection of the measuring diaphragm will change the internal output voltage of the pick-up system.

Silicon pressure sensor

In case of silicon pressure sensors, the pressure is transferred via the separation diaphragm and the filling fluid to the measuring diaphragm. The resistance values of the four piezo resistors doped in the measuring diaphragm will change.

This pressure-proportional, internal output voltage is converted via the electronic unit into a scaled electrical signal. Depending on the model, the transmitter is connected to the process by means of a spigot G ½ B (DIN EN 837-1), ½-14 NPT male or female thread, flush diaphragm with special thread G ½" for, e.g., ball valve connection or different pressure sensors.

The pressure transmitter operates on the basis of two-wire technology. The same wires are used for the operating voltage (device-specific, see "Specifications") and the scaled output signal. The electrical connection is established via a cable entry or plug.

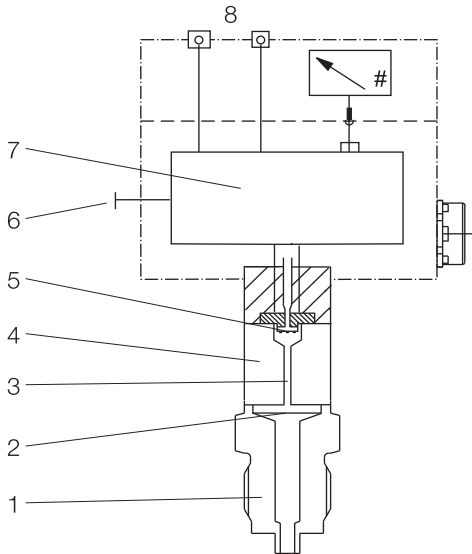

M10705

Fig. 4: 261G transmitter for gauge pressure and fill level (example)
 1 Process connection | 2 Separation diaphragm | 3 Filling fluid |
 4 Measuring cell | 5 Pressure sensor |
 6 Pushbutton for lower / upper range values |
 7 Microprocessor-controlled electronics | 8 Output / Supply power

To measure the output signal and to configure or calibrate the pressure transmitter, an ammeter must be connected directly to the output circuit.

The lower and upper range values can be set via a pushbutton on the electronic unit.

An optional fastener is available for attaching a stainless steel tag so that the measuring points can be indicated.

The transmitter may also be equipped with an LCD indicator that can be read from above (optional, can be retrofitted). With the aid of this LCD indicator, the most important transmitter functions or data can be fully configured using the “local” control unit (four pushbuttons on the indicator) (see “Configuration”).

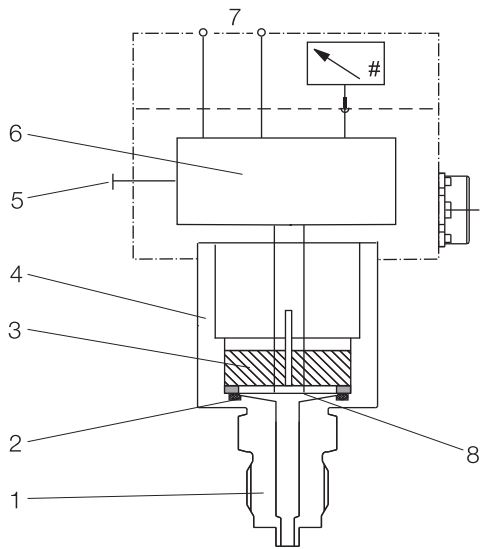

M10706

Fig. 5: 261A transmitter for absolute pressure (example)
 1 Process connection | 2 O-ring | 3 Measuring capsule |
 4 Measuring equipment |
 5 Pushbutton for lower / upper range values |
 6 Microprocessor-controlled electronics |
 7 Output / Supply power | 8 Measuring diaphragm

4 Mounting

Before installing the transmitter, check whether the device design meets the requirements of the measuring point from a measurement technology and safety point of view. This applies in respect of the:

- Measuring range
- Gauge pressure stability
- Temperature
- Explosion protection
- Operating voltage

The suitability of the materials must be checked as regards their resistance to the media. This applies in respect of the:

- Seal
- Process connection, separation diaphragm, etc.

In addition, the relevant directives, regulations, standards, and accident prevention regulations must be observed (e.g., VDE / VDI 3512, DIN 19210, VBG, Elex V, etc.).

Measurement accuracy is largely dependent on correct installation of the pressure transmitter and, if applicable, the associated measuring pipe(s).

As far as possible, the measuring setup should be free from critical ambient conditions such as large variations in temperature, vibrations, or shocks.



IMPORTANT (NOTE)

If unfavorable ambient conditions cannot be avoided for reasons relating to building structure, measurement technology, or other issues, the measurement quality may be affected. (See "Specifications").

If a remote seal with capillary tube is installed on the transmitter, the additional operating instructions for remote seals and the related data sheets must be observed.

4.1 Pressure transmitter

The pressure transmitter can be connected directly to the shut-off valve. An angle bracket for wall or pipe mounting (2" pipe) is also available as an accessory.

The pressure transmitter should be installed so that the display and control unit are accessible during installation and connection, as well as retrofitting.

Ideally, the pressure transmitter should be mounted in a vertical position with the process connection pointing downward to prevent subsequent zero position shifts.



IMPORTANT (NOTE)

If the pressure transmitter is installed at an angle, depending on the measuring range the filling fluid exerts hydrostatic pressure on the measuring diaphragm, resulting in a zero position shift. The zero point must then be adjusted.

However, in principle the pressure transmitter can be used in any mounting position. It is mounted by following the same guidelines as for a manometer.

For mounting options with an angle bracket, see the section "Specifications".

4.2 Sealing and screw connections

Connecting G ½ B spigot:

For sealing, a flat gasket must be used in accordance with DIN EN 837-1.

NPT threaded connection:

Seal the threads with Teflon or another approved resistant sealant.

Process connection with flush diaphragm:

Prior to mounting the device, install a welded connection or tapped hole according to relevant soldering standards (for process connection and welded connection dimensions, see "Specifications").

Process connection for ball valve:

An appropriate ball valve connection or weld-in sleeve is required for mounting purposes. In this case, the seal is formed by a cone at the outer end of the process connection (metal/metal). For information on the weld-in sleeve, see "Specifications".

4.3 Moisture

Use suitable cables and tighten cable glands securely. The transmitter can also be protected against the ingress of moisture by routing the connecting cable downward before securing it. This allows rain and condensation to drip down. This is especially important for installation in outdoor areas and rooms that are exposed to moisture (e.g., due to cleaning processes) or on cooled or heated tanks.

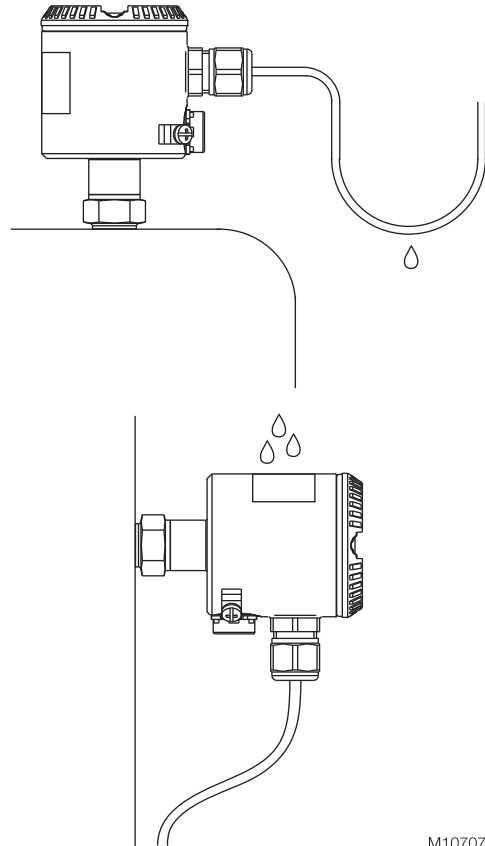

M10707

Fig. 6: Steps for preventing the ingress of moisture

4.4 Measuring pipe

In order for the pipes to be laid correctly, the following points must be observed:

- Keep the measuring pipe as short as possible and avoid sharp bends.
- Lay the measuring pipe in such a way that no deposits can accumulate in it. Gradients should not be less than approx. 8 % (ascending or descending).
- The measuring pipe should be blown through with compressed air or, better yet, flushed through with the measuring medium before connection.
- Completely depressurize the measuring pipe if the medium is a fluid.
- Lay the measuring pipe in such a way that gas bubbles (when measuring fluids) or condensate (when measuring gases) can flow back into the process line.
- When measuring steam, lay the measuring pipe in such a way that hot steam cannot flow back into the process connection (water trap, e.g., a water trap pipe that is filled with water before installation).
- Check the tightness of the connection.

5 Electrical connections



WARNING – Electrical dangers!

Observe the applicable regulations governing electrical installation. Connections must only be established in a dead-voltage state. The transmitter has no switch-off elements. Therefore, overcurrent protective devices, lightning protection, or voltage disconnection options must be provided at the plant.

Check that the existing operating voltage corresponds to the voltage indicated on the name plate.

The same lines are used for both the power supply and output signal.

5.1 Cable connection

Depending on the model supplied, the electrical connection is established via cable gland M16x1.5 (for diameters of 5 to 10 mm) or M20x1.5 (for diameters of 6 to 11 mm), a threaded bore for cable gland 1/2-14 NPT, or via the Han 8U plug, i.e., via the miniature plug connector M12 x 1 (see also "Technical specification / Electrical connections").

The screw terminals are suitable for wiring cross-sections up to 1.5 mm².

It is recommended that you strip approx. 30 ... 35 mm (1.18 ... 1.38 inch) off the cable jacket.

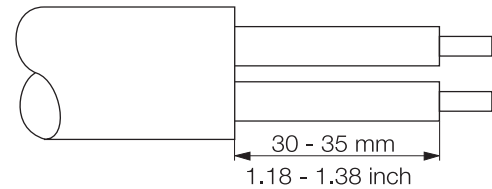

M10708

Fig. 7: Stripped connecting cable

i IMPORTANT (NOTE)

After a period of several weeks, removing the screws in the housing cover requires increased force. This is not caused by the threads, but instead is due solely to the type of seal.

5.2 Electrical connection in the cable connection area

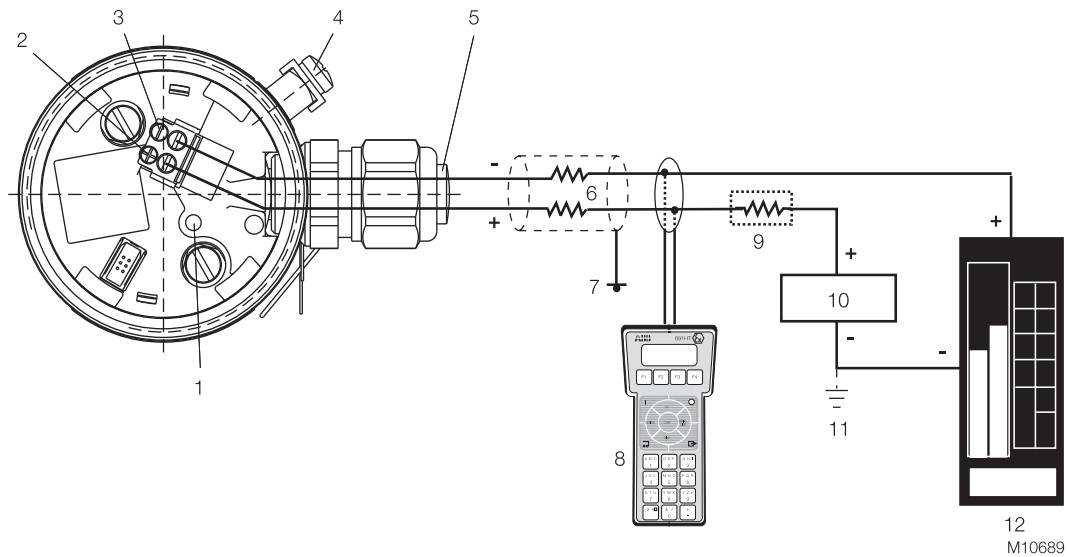

Fig. 8

- 1 Pushbutton for lower/upper range values | 2 + Signal screw terminals for leads with cross-section of 0.5 ... 1.5 mm² |
 3 - Signal screw terminals for leads with a cross-section of 0.5 ... 1.5 mm² | 4 Grounding / equipotential bonding terminal (optional) |
 5 Cable entry | 6 Line load | 7 Grounding | 8 Handheld terminal | 9 Resistor (min. 250 Ω) | 10 Power supply / power supply unit |
 11 Optional ground | 12 Receiver

application	Permissible voltage range of power supply
Transmitter operated outside the potentially explosive atmosphere.	11 ... 42 V
Transmitter operated inside the potentially explosive atmosphere.	11 ... max. 30 V (intrinsically safe)



WARNING! Risk of explosion!

If, when using transmitters with type of protection "intrinsic safety", an ammeter is connected to the output circuit or a modem is connected in parallel while there is a risk of explosion, the sums of the capacitances and inductances of all circuits, including the transmitter (see EC-type-examination certificate) must be equal to or less than the permissible capacitances and inductances of the intrinsically safe signal circuit (see EC-type-examination certificate for the power supply unit).

Only passive or explosion-proof devices or indicators may be connected.

5.3 Electrical connection with plug

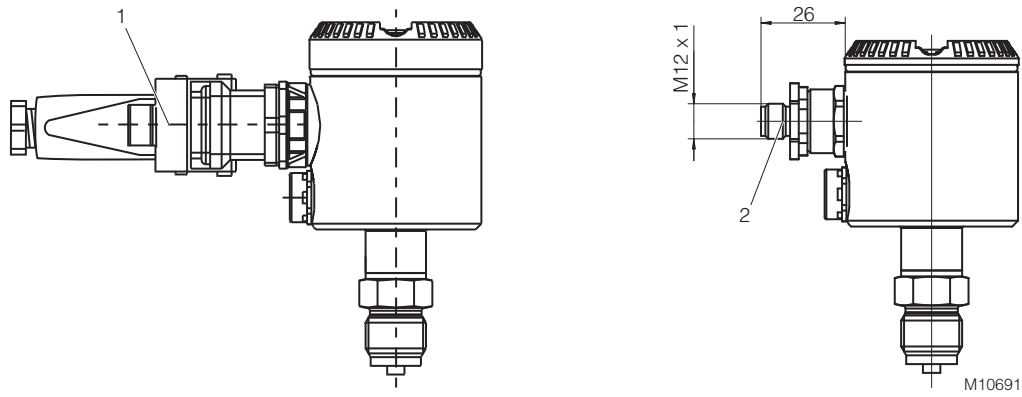

Fig. 9: Connection via plug connection
 1 Harting Han 8D (8U) plug connection | 2 M12 x 1 miniature plug connector

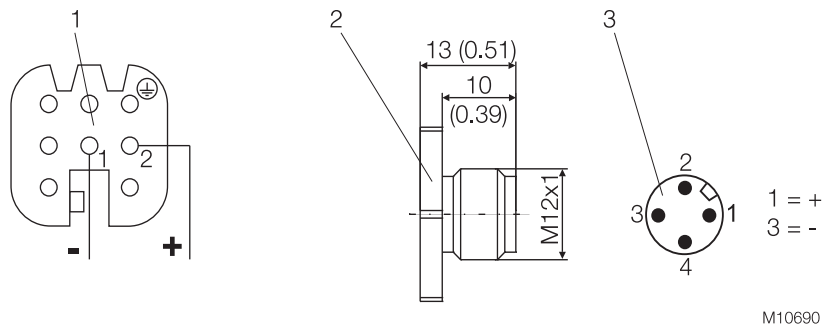

Fig. 10: Pin assignment
 1 Harting Han 8D (8U) socket insert for mating plug supplied (view of sockets) |
 2 Mating plug (socket); not supplied | 3 M12 x 1 miniature plug (pins)

5.3.1 Assembly and connection of Han 8D (8U) socket connector

The socket connector for connecting the cable is supplied unassembled as an accessory for the transmitter.

i IMPORTANT (NOTE)

Please observe the specifications for the electrical connection that have been supplied with the connector.

Assembly is depicted in the figure below.

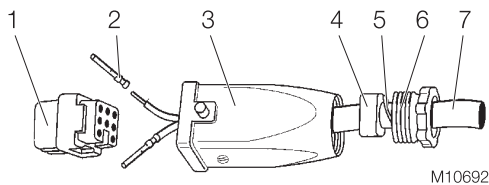

Fig. 11: Assembling the socket connector

- 1 Socket | 2 Contact | 3 Socket shell |
- 4 Gasket (can be cut) | 5 Thrust collar |
- 6 PG 11 pressure screw |
- 7 Cable (diameter 5 ... 11 mm (0.20 ... 0.43 inch))

1. The contacts are crimped or soldered onto the cable ends (wire cross-section of 0.75 ... 1 mm² (AWG 18 ... AWG 17)), from which approx. 1.5 ... 2 cm (0.59 ... 0.79 inch) of the sleeve and approx. 8 mm (0.32 inch) of the insulation have been stripped; they are then inserted into the socket from the rear.
2. Slide the pressure screw, thrust collar, gasket, and socket shell onto the cable in the order indicated before assembly (you may have to adjust the gasket to fit the cable diameter).

5.4 Protective conductor/Grounding (optional)

A terminal is available on the outside of the housing for grounding (PE) the transmitter.

5.5 Communication setup

The transmitter can be operated via a modem, using a PC or laptop. The modem can be connected to the transmitter in parallel at any point in the signal circuit. Communication between transmitter and modem occurs via AC signals that are superimposed on the analog 4 ... 20 mA output signal. This modulation occurs without averaging and does not, therefore, affect the measuring signal.

Communication between transmitter and PC or laptop is only possible if the signal circuit is set up as shown in the following figure, "Communication mode: Point-to-point". The resistance between the connecting point for the FSK modem and the power supply must be at least 250 Ω (including internal resistance of the power supply unit). If this value is not achieved within the context of normal installation, an additional resistor must be used.

The ABB Contrans I supply modules with HART communication already have a factory-installed, additional resistor. Some of these modules offer the option of communicating directly over the supply module in the operating mode "FSK bus".

Power can be supplied by power supply units, batteries, or power supplies; these must be designed to ensure that the operating voltage U_B of the transmitter always remains between DC 11 V and 42 V (30 V for "Ex i").

In addition, the maximum current of 20 ... 23.6 mA resulting from overranging must be considered, depending on the corresponding parameterization. This yields the minimum value for US.

If additional signal receivers (e.g., indicators) are looped into the signal circuit, their resistance must also be considered.

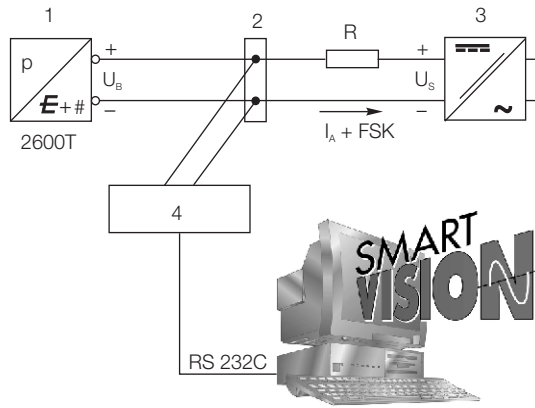

M10693

Fig. 12: "Point-to-point" communication mode

1 Pressure transmitter | 2 Possible connecting points for a modem between A and B | 3 Power supply unit | 4 FSK modem

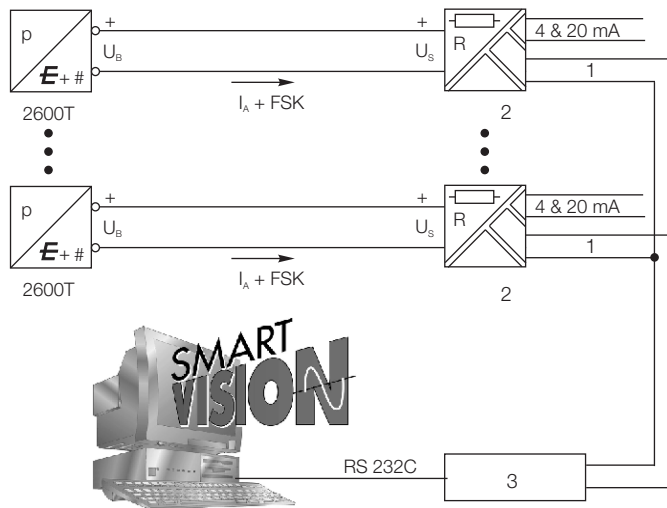

M10694

Fig. 13: "FSK bus" communication mode

1 FSK bus | 2 Supply module with HART isolation | 3 FSK modem

5.6 Connecting cable

Communication between the transmitter and PC or laptop is only possible if the cabling meets the following requirements: The minimum wire diameter depends on the line length.

Line lengths up to 1,500 m: 0.51 mm
Line lengths above 1,500 m: 0.81 mm

The maximum line length is limited.

Dual-core cable: 3,000 m

Multi-core cable: 1,500 m

The actual possible line length of the electrical circuit depends on the total capacitance and total line resistance, and can be estimated using the following formula:

$$L = \frac{65 \times 10^6}{R \times C} - \frac{C_f + 1000}{C}$$

L = Line length in m

R = Total line resistance in Ω (ohms)

C = Line capacitance in pF/m

C_f = Capacitance of the devices located in the circuit in pF

Avoid routing cables with other electrical cables (with inductive load, etc.) or near large electrical equipment.

6 Commissioning

6.1 General remarks

Once the pressure transmitter has been installed, it is put into operation by switching on the operating voltage.

Check the following before switching on the operating voltage:

- Process connections
- Electrical connection
- The measuring pipe and measuring chamber of the measuring equipment must be completely filled with the measuring medium.

The transmitter can then be put into operation.

To do this, the shut-off valves must be actuated in the following order (in the default setting, all valves are closed):

1. Open the discharge shut-off valve, if present.
2. Open the shut-off valve.

To put the transmitter out of operation, carry out the steps in reverse order.



IMPORTANT (NOTE)

In the case of pressure transmitters for absolute pressure that feature a ceramic pressure sensor and measuring ranges of ≤ 40 kPa absolute, please be aware that the pressure measuring cell will have been overloaded by the atmospheric pressure due to the long periods of transport and storage involved. For this reason, you will need to allow a starting time of approx. 3 hours after commissioning, until the sensor has stabilized to such an extent that the specified accuracy can be maintained.

If, when using transmitters with type of protection "intrinsic safety", an ammeter is connected to the output circuit or a modem is connected in parallel while there is a risk of explosion, the sums of the capacitances and inductances of all circuits, including the transmitter (see EC-type-examination certificate) must be equal to or less than the permissible capacitances and inductances of the intrinsically safe signal circuit (see EC-type-examination certificate for the power supply unit).

Only passive or explosion-proof devices or indicators may be connected.

If the output signal stabilizes only slowly, it is likely that a large damping time constant has been set on the transmitter.

6.2 Output signal

If the applied pressure is within the values indicated on the name plate, the output current ranges between 4 and 20 mA. If the pressure applied falls outside the set range, the output current will be between 3.5 mA and 4 mA if the range is undershot or between 20 mA and 23.6 mA if the range is overshoot (depending on the respective configuration).

Standard setting for normal operation

3.8 mA / 20.5 mA

A current that is < 4 mA or > 20 mA may also indicate that the microprocessor has detected an internal error.

Standard setting for error detection

21 mA

The graphical user interface (DTM) can be used to diagnose the error.



IMPORTANT (NOTE)

A brief interruption in the power supply results in initialization of the electronics (program restarts).

6.3 Write protection

Write protection prevents the configuration data from being overwritten by unauthorized users. If write protection is enabled, the "Lower Range Value / Upper Range Value" pushbutton will be disabled.

It is still possible to read out the configuration data via optional LCD indicator, handheld terminal or the graphical user interface (DTM).

Write protection can be disabled via the graphical user interface (DTM), a HART handheld terminal, or an optional LCD indicator (see "Write protection" under "Configuration").

6.4 Adjusting lower range value / oblique sensor

During installation of the transmitter, zero position shifts may occur due to the mounting position; these must be corrected. Possible causes include:

- Transmitter mounting position is different from recommended vertical mounting position
- Fluids in differential pressure lines or remote seal capillary tubes can generate additional hydrostatic pressure



IMPORTANT (NOTE)

The transmitter must have reached its operating temperature (approx. 5 min. after startup, if the transmitter has already reached the ambient temperature) in order to perform the zero shift correction.

There are two options (variant A or B) for correcting the 4 ... 20 mA output signal directly on the transmitter.

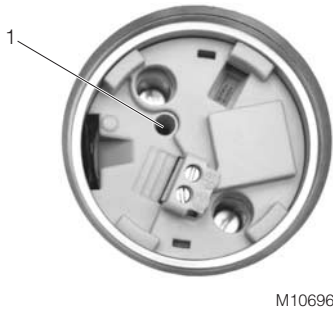

Fig. 14:
1 Pushbutton (in hole)

Variant A, with pushbutton in device.

1. Make sure that the measured variable corresponds to the start value for the measurement process, i.e., that the pressure that the process exerts on the transmitter is the level of pressure required to generate a 4 mA output signal. The pressure must be stable (observe set damping level).
2. Unscrew the housing cover and press the pushbutton in the bore hole on the electronic unit (see the following figure) using a pin with diameter of ≤ 2.5 mm. Hold the pushbutton down for a maximum of 1 s. The output signal is set to 4 mA. The span remains unchanged.
3. Screw the housing cover back on.



IMPORTANT (NOTE)

The lower range value is stored to a failsafe memory approx. 25 s after you activate the pushbutton.

Correction procedure "A" described above does not affect the physical pressure shown; it only corrects the analog output signal. For this reason, the analog output signal may differ from the physical pressure shown on the digital display or the communication tool.

To avoid this discrepancy, you need to correct the zero position shift (zero shift) as described under variant "B".



IMPORTANT (NOTE)

The procedure described in "A" above does not affect the physical pressure shown; it only corrects the analog output signal. For this reason, the analog output signal may differ from the physical pressure shown on the digital display or the communication tool.

To avoid this discrepancy, you need to correct the zero position shift (zero shift) as described under variant "B".

Variant B, with pushbuttons on the optional LCD indicator.

1. Make sure that the process pressure corresponds to the atmospheric pressure $P_e = 0$ (with 261Gx) or a complete vacuum $P_{abs} = 0$ abs (with 261Ax). The pressure must be stable (observe set damping level).
2. Unscrew the housing cover and select the "Calibrate_Zero Trim" menu item on the LCD indicator.
3. The correction is made by pressing the  button (for details of menu control, see "Configuration with the LCD indicator").
4. Where the transmitter mounting position differs from the nominal position, we recommend that you also compensate for the temperature-dependent effect of this mounting position. To do this, select the "Device Setup_Installation angle" menu item (software version 1.5.0 or higher). This shows the angle at which the transmitter has been installed.
5. Screw the housing cover back on.

6.5 Installing/Removing the LCD indicator

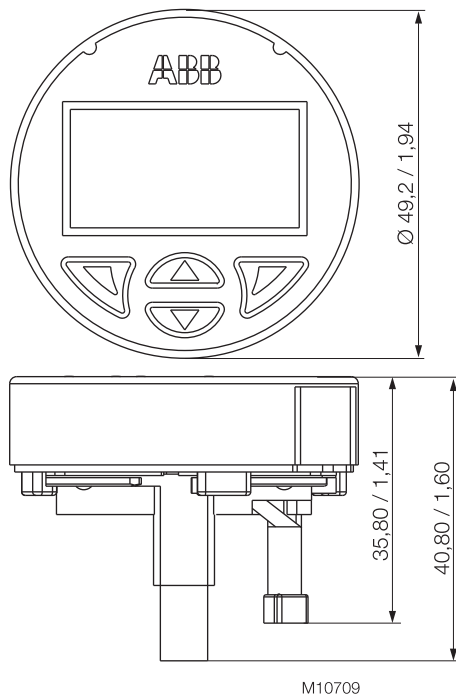

Fig. 15:

The LCD indicator is attached to the housing of the pressure transmitter. The LCD indicator can be replaced, e.g., if defective.



WARNING – Risk of burns!

The connection head can become very hot as a result of the process. There is a danger of burns.

Switch off the LCD indicator before replacing the LCD indicator.

The transmitter atmosphere may be explosive.
Risk of explosion!

- 1 Unscrew the housing cover for the transmitter.
- 2 Carefully remove the LCD indicator from the inset for the transmitter. The LCD indicator is held firmly in place, meaning that you may have to use the tip of a screwdriver to pry it loose. Take care to avoid any mechanical damage.

- 3 No tools are required to insert the LCD indicator. Carefully insert both guide pins for the LCD indicator in the guide holes of the transmitter inset. Make sure the black connection socket fits into the terminal on the transmitter inset. The red outer flat ribbon cable marking is on the inside facing the middle of the device. Then press it in as far as it will go. Make sure that the guide pins and connection socket are fully inserted.



IMPORTANT (NOTE)

The LCD indicator is designed with type of protection "intrinsic safety" and is covered by the transmitter's EC type-examination certificate.

Following this, the position of the LCD indicator can be adjusted to suit the installation position of the transmitter, to ensure that the display is legible. The LCD indicator has twelve positions that can be set in 30° increments.



NOTICE – Potential damage to parts!

Make sure the flat ribbon cable does not get twisted or torn when rotating the LCD indicator.

- 4 The LCD indicator consists of an upper and a lower part. Both parts are connected to each other via a bayonet lock. Carefully rotate the top part of the LCD indicator approx. 45° to the left, in order to detach it from the bottom part of the indicator.
- 5 Carefully lift the LCD indicator into the desired position in the bottom part and rotate to the right until it snaps into place.



NOTICE – Potential damage to parts!

Take care not to pinch the flat ribbon cable when rotating the LCD indicator.

- 6 Screw on the housing cover for the transmitter.

6.6 Pressure sensor ventilation



Fig. 16: Ventilation unit

For technical reasons, you must apply atmospheric pressure to the reference side of the pressure sensor.

A special ventilation unit (1) is screwed into the electronic housing from the outside and is equipped with a PTFE filter on the inside. Make sure that the ventilation opening is not covered (e.g., do not paint over).

7 Configuration, parameterization



NOTICE – Potential damage to device as a result of electrostatic charging!

When the housing is open, EMC protection is impaired and there is no longer any protection against accidental contact.

Do not touch conductive parts of the device.

7.1.1 Standard configuration

Transmitters are set to the customer's specified span at the factory. The set range and measuring point number are provided on the name plate. If this data has not been specified, the transmitter will be delivered with the following configuration:

Parameter	Factory setting
4 mA	Zero position
20 mA	Measuring range upper limit (URL)
Output	Linear
Damping	0.1 s
Transmitter failure mode	21 mA
Optional LCD display	0 ... 100 %

Any or all of the configurable parameters listed above - including the upper and lower range values - can easily be changed using the optional LCD indicator, a HART handheld communicator, or a PC running the configuration software SMART VISION with DTM for 2600T.

7.2 Configuration types

Pressure transmitters can be configured as follows:

- Configuration using pushbutton on pressure transmitter.
- Configuration with the LCD indicator.
- Configuration with the PC / laptop or handheld terminal.
- Configuration via graphical user interface (DTM).

7.3 Configuration using pushbutton on pressure transmitter

7.3.1 General remarks

The pushbutton is located on the electronics unit (without mounted LCD indicator).

The pushbutton is used to set the "Lower Range Value" (0 %) and "Upper Range Value" (100 %) parameters.

To access the pushbutton, you must remove the housing cover for the electronics unit.

The pushbutton (1) is located in the bore hole and can be pressed with a pin or screwdriver with a diameter of ≤ 2.5 mm.

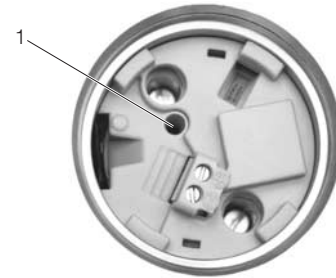

M10696

Fig. 17: Pushbutton position

7.3.2 Configuration

The "Lower Range Value" and "Upper Range Value" parameters can be set directly on the transmitter using a button. The transmitter has been set by the manufacturer based on the order information.

The name plate contains information on the "Lower Range Value" and "Upper Range Value" that have been set.

In general, the following applies:

For a setting, e.g., of 0 ... 40 kPa, the first pressure value (0 kPa) is always assigned to the 4 mA signal and the second pressure value (40 kPa) is always assigned to the 20 mA signal.

To reset the transmitter, apply the pressure for the "Lower Range Value" and "Upper Range Value" to the measuring equipment. Make sure that the measuring limits are not exceeded.

Reducing stations can be used as transducers with adjustable pressure and reference displays.



IMPORTANT (NOTE)

When making the connection, please ensure that there are no residual fluids (for gaseous measured media) or air bubbles (for fluid measured media) in the connection lines, since these can lead to errors during inspection.

Any potential measuring error for the pressure generator should be at least three times smaller than the desired measuring error for the transmitter. It is recommended that, if time constant is known, you set the damping to zero (via LCD indicator or graphical user interface).

i **IMPORTANT (NOTE)**

In the case of 261A pressure transmitters for absolute pressure that feature measuring ranges of ≤ 40 kPa absolute, please be aware that the pressure measuring cell will have been overloaded by the atmospheric pressure due to the long periods of transport and storage involved. For this reason, you will need to allow a starting time of approx. 3 hours after commissioning, until the sensor has stabilized to such an extent that the specified accuracy can be maintained.

Adjusting the "Lower Range Value" and "Upper Range Value" parameters

1. Apply the pressure for the "Lower Range Value" and wait approx. 30 s until it has stabilized.
2. Setting for "Lower Range Value": Press the pushbutton for 1 s. The output current is set to 4 mA.
3. Apply the pressure for the "Upper Range Value" and wait approx. 30 s until it has stabilized.
4. Setting for "Upper Range Value": Press and hold the pushbutton for approx. 5 s. The output current is set to 20 mA.
5. If required, reset the damping to its original value.
6. Record the new settings. Approx. 25 s after the pushbutton for the 0 % or 100 % setting is pressed, the respective parameter is stored in the non-volatile memory.

i **IMPORTANT (NOTE)**

This configuration procedure only changes the 4 ... 20 mA current signal. The physical process pressure shown on the digital display or user interface is not affected. To avoid potential discrepancies, you can make corrections by following the menu path "Calibrate_Pressure Measurement_Balance Points" in the user interface. After performing a correction, you must check the settings for the device.

7.4 Configuration with the LCD indicator

i **IMPORTANT (NOTE)**

To access the control buttons for the LCD indicator, you must unscrew the housing cover with the inspection glass.

7.4.1 Menu navigation

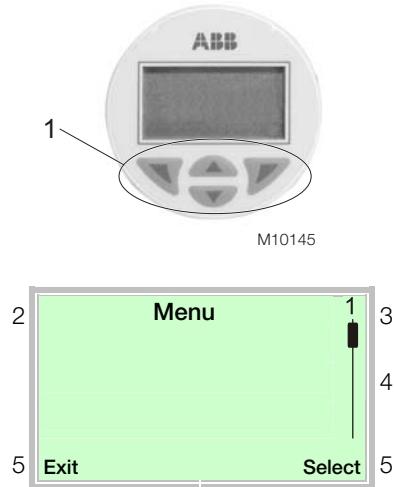

Fig. 18: LCD display

- 1 Operating buttons for menu navigation |
- 2 Menu name display | 3 Menu number display |
- 4 Marker for indicating the relative position within the menu |
- 5 Display showing the current functions of the and operating buttons

You can use the or operating buttons to browse through the menu or select a number or character within a parameter value.

Different functions can be assigned to the and operating buttons. The function that is currently assigned to them (5) is shown on the LCD display.

Control button functions

	Meaning
Exit	Exit menu
Back	Go back one submenu
Abort	Cancel a parameter entry
Next	Select the next position for entering numerical and alphanumeric values

	Meaning
Select	Select submenu / parameter
Edit	Edit parameter
OK	Save parameter entered

7.4.2 Process display

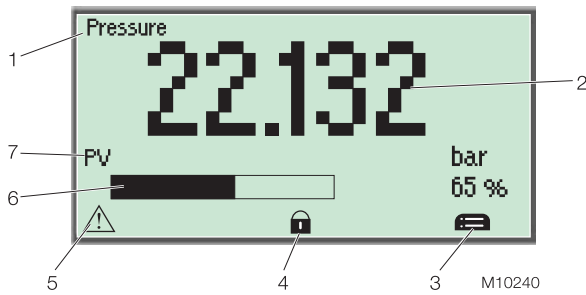

Fig. 19: Process display (example)

- 1 Line 1: Measuring point identifier |
- 2 Line 2: Current process values |
- 3 Symbol indicating button function |
- 4 "Write protection" symbol | 5 Diagnostic message |
- 6 Bargraph + numerical % value |
- 7 Line 3: Displays the variable / unit shown in line 2

The process display appears on the LCD display when the device is switched on. It shows information about the device and current process values.

The way in which the current process values (2) are shown can be adjusted on the configuration level.

The decimal point is positioned automatically so that the maximum value can be displayed as a six-figure value. If the value is exceeded, "Overflow" is shown as six upward or downward pointing arrows. A decimal point counts as a place and is no longer displayed after the sixth place.

Symbol description

Symbol	Description
	Call up configuration level.
	Write protection is enabled. The device is protected against changes to the parameter settings.

Example of positioning the decimal point:

Setting 0 ... 1000.0 – in this case, even smaller values are only displayed with one decimal place.

Decimal places for variables

The following variables are displayed with a fixed decimal place:

Variable	Decimal places
Temperature (sensor temperature)	1
Output (%)	1
Current (output current)	2

Error messages on the LCD display

In the event of an error, a flashing message consisting of an icon and text (e.g., device defective) appears at the bottom of the process display. If you press the left LCD indicator button while a message is flashing, the text becomes permanent. A write protection icon will be covered by one of the above messages.

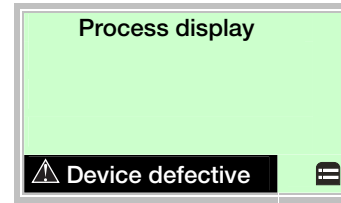

Symbol	Priority	Description
	1	Error message Device defective, refers to a serious device error (the device must be replaced).
	2 3	Warning message Refers to specific operating conditions or events (e.g., simulation active, maintenance required).
	4a 4b 4c	Process message Indicates that a parameter has fallen below or exceeded a process alarm condition.

7.4.3 Switching to the configuration level (parameterization)

The device parameters can be displayed and changed on the configuration level.

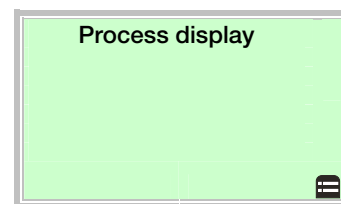

8. Use to switch to the configuration level.

7.4.4 Menu structure

The parameters are structured in the form of a menu. The menu consists of a maximum of three levels. Menu items with an asterisk (*) have additional parameters that are described in the next section.

main menu	Submenu 1	Submenu 2	Process units
Device Setup	Write Protect	yes	atm
		no	bar
	Apply Process Variable*	Lower Range Value	ft H ₂ O (68 °F)
		Upper Range Value	g/cm ²
	Set Process Variable*	Unit	in H ₂ O (4 °C)
		Lower Range Value	in H ₂ O (60)
		Upper Range Value	in H ₂ O (68)
	Offset*	Num. value entry (%)	in Hg (0 °C)
			kg/ cm ²
	Damping*	Num. value entry (s)	kPa
			mbar
	HART Output*	Unit	mm H ₂ O (4 °C)
		Lower Range Value	mm H ₂ O (68)
		Upper Range Value	mm Hg (0 °C)
Fault Current	Upscale	MPa	
	Downscale	Pa	
Installation angle	0 degrees	psi	
	45 degrees	Torr	
Factory Reset	90 degrees		
	135 degrees		
	180 degrees		
Display	Main Operator View	Process Variable	HART output units
		HART Output	atm
		Output Current	bar
		Output %	ft H ₂ O (68 °F)
		Temperature	g/cm ²
	Bargraph	yes	in H ₂ O (4 °C)
		no	in H ₂ O (60)
	Contrast		in H ₂ O (68)
			in Hg (0 °C)
	Language	English	kg/ cm ²
Deutsch		kPa	
Diagnosis	Process Variable		mbar
			mm H ₂ O (4 °C)
			mm H ₂ O (68)
			mm Hg (0 °C)
			MPa
Communication	HART Tag		Pa
			psi
Calibrate	Zero Trim		Torr
			cm
			ft
			in, m, mm, %, special

7.4.5 Parameter descriptions

Enabling / disabling (Write Protect)

Via LCD indicator, DTM or handheld terminal.

If "Write Protect" is enabled, it is not possible to configure the 261G/A pressure transmitter. All editing functions on the indicator are hidden, except for write protection. It is, however, possible to read out data. Write protection is applied for the entire device.



IMPORTANT (NOTE)

In addition, the "Local operation" option can be disabled via the graphical user interface (DTM) or a handheld terminal (HHT).

Editing functions are also hidden when the "Local operation" option is disabled, i.e., the 261G/A pressure transmitter is no longer configurable via the LCD indicator.

The "Local operation" option can only be enabled via the graphical user interface (DTM) or a handheld terminal.

Apply Process Variable

Set "Lower Range Value" and "Upper Range Value" with applied pressure on the device via the process or a pressure generator.

1. Apply the pressure for the "Lower Range Value" and wait approx. 30 s until it has stabilized.
2. Setting for "Lower Range Value": Click the right pushbutton for "OK" – The output current is set to 4 mA.
3. Apply the pressure for the "Upper Range Value" and wait approx. 30 s until it has stabilized.
4. Setting for "Upper Range Value": Click the right pushbutton for "OK" – The output current is set to 20 mA.

Set Process Variable

Set "Lower Range Value" and "Upper Range Value" without applied pressure by entering the corresponding pressure values via keypad.

Offset

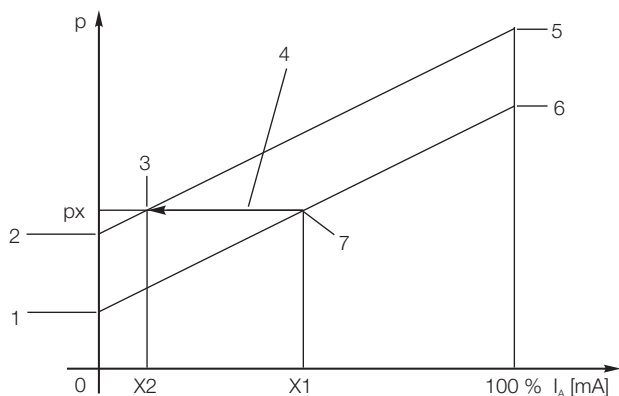

M110699

Fig. 20: Offset shift

- 1 Old zero | 2 New zero | 3 New balance point |
4 Offset shift | 5 New end value | 6 Old end value |
7 Old balance point

This function performs an offset shift of the characteristic so that it travels through a point specified by the user. This makes it possible to set the output signal of several measuring devices that measure the same process variable to the same value, without the need to perform calibration with applied pressure.

This function can be performed at any point on the characteristic under the following circumstances:

- Process variable is within the configured measuring range. The transmitter has a linear transmission characteristic.
- Enter the desired output current as a percentage to perform an offset shift for the measuring range.
- When a pressure p_x is applied, the transmitter displays the standardized output value x_1 as a percentage. Based on the current application, however, the value x_2 should be displayed. The value x_2 in % is set via the LCD indicator. The transmitter calculates the new zero and the new end value, and adopts these new settings (see the figure "Offset shift").

Damping

When the output signal for the transmitter is noisy as a result of the process, the signal can be smoothed (damped) electrically.

The additional time constant can be set between 0 s and 60 s in increments of 0.0001 s.

Damping does not affect the measured value shown in the digital display as a physical unit. It only affects the quantities derived from it such as the analog output current, HART output (freely assigned start value, end value and unit).

HART Output

HART output refers to freely assigned start value, end value and unit for the pressure measured. If the values are configured so that the 0 % and 100 % points correspond to 5 m and 20 m respectively, the HART output will indicate a value of 12.5 m at a pressure of 50 %.

Fault current

If a serious error is detected during the internal monitoring routines run by the transmitter, the transmitter switches the output signal to a specified minimum or maximum value as a message.

Use the menu item "Fault Current" to select the alarm response and the modulation direction of the output current in the event of a malfunction.

"Upscale" (High alarm) means that the output current is switched to the configured high alarm current.

"Downscale" (Low alarm) switches the output current to the configured low alarm current. The level of the low or high alarm current can only be changed using the graphical user interface (DTM) or handheld terminal with loaded DD (device description) of the 261 transmitter.

Setting limits:

- Min. alarm current: 3.5 ... 4 mA
- Max. alarm current: 20 ... 23.6 mA

Default setting from factory:

- Max. alarm current: 21 mA

Installation angle

You can specify the extent to which the transmitter deviates from the recommended nominal position (vertical, process connection pointing downward) by selecting one of the angular degree settings displayed. This compensates for the temperature-dependent effect of the mounting position.

Factory Reset

Restores the transmitter settings to the factory default.

Display – Main Operator View

The parameters listed can be displayed permanently in this view (failsafe memory).

Contrast

If the lighting conditions are unfavorable, making it difficult to read the LCD indicator, you can adjust the background by making it darker or lighter (▲ or ▼ buttons).

The default setting is 50 %. If the menu cannot be read because the contrast has been adjusted too much or because of unfavorable conditions, e.g., change in temperature, pressing both outer buttons together for > 5 s will restore the default contrast settings.

Diagnosis

The parameters listed can be displayed temporarily in this view (not failsafe memory). The value configured under "Main operator view" remains unchanged.



IMPORTANT (NOTE)

The LCD indicator automatically returns to the process display approximately three minutes after the last button was pressed.







HART Tag

Each transmitter requires a unique bus ID in order to communicate within a bus structure. The bus ID (tag) can be entered via the "Communication" function and is subject to a maximum length of 8 characters. Characters can include uppercase letters, numbers, spaces and a few special characters.

Editing the "HART Tag":

Access menu via "Communication" according to the menu structure (see "Menu structure").

The Edit mode can be accessed via "Select" or "Edit" (see "Alphanumeric entry").

1. Select the required characters one by one and character by character from the character selection bar in the centre using the two buttons  (character block moves to the left) and  (character block moves to the right). A character is selected when the cursor is positioned on the character and the background is dark. The selected character is added to the upper area where the Tag Name is displayed.
2. Use the left button  (Next) to move to the next editing area for the tag name.
3. Once the tag name has been entered fully (max. 8 characters), confirm by pressing the right button  (OK). Press the button  (Next) repeatedly to move the cursor to the right. Once the cursor reaches the ninth position, "Cancel" is displayed bottom right.
4. Cancel terminates and exits the Edit mode. To return to the start, press the left button  (Next).

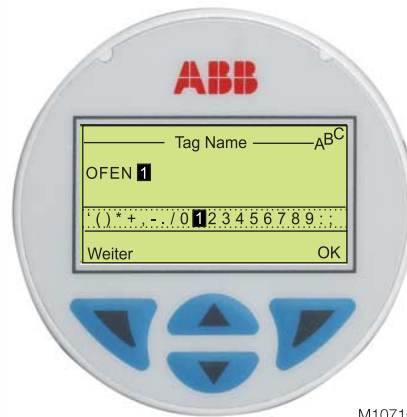

Fig. 21:

M10710



Fig. 22:

M10711

Zero Trim

This function allows a zero shift of the process pressure read in from the measuring cell.

If, for example, the transmitter displays a small pressure value at a "0 Pa" process pressure (transmitter was not installed precisely in vertical position), this pressure can be adjusted to "0 Pa".

7.5 Configuration with the PC/laptop or handheld terminal

A graphical user interface (DTM) is required for configuration of the transmitter via PC or laptop. For operating instructions, please refer to the software description.

Further information:

Data sheet for the DTM / SMART VISION

Communications protocol:

HART®

Hardware:

FSK modem for PC or laptop

HART handheld terminal (HHT):

e.g., 691 HT, HHT275/375, DHH800-MFC

You can use a handheld terminal to read out or configure/calibrate the transmitter. If a communication resistor is installed in the connected power supply unit, you can connect the handheld terminal directly at any point along the 4 ... 20 mA line.

If no communication resistor is present (min. 250 Ω), you will need to install one in the line. The handheld terminal is connected between the resistor and transmitter, not between the resistor and power supply unit.

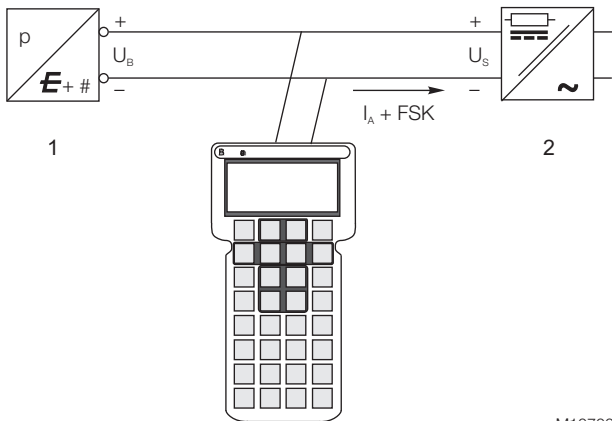

M10700

Fig. 23: Communication resistor in power supply unit
1 Transmitter | 2 Power supply unit

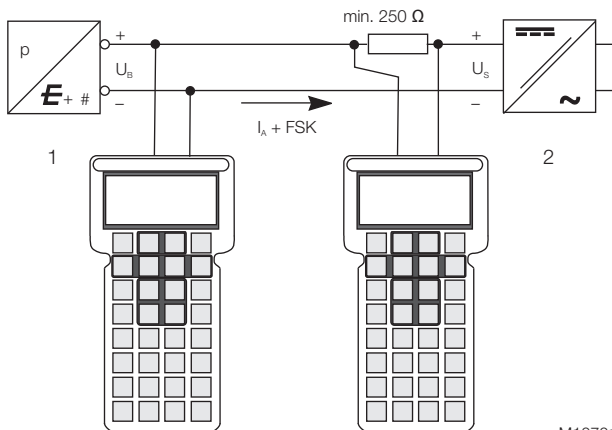

M10701

Fig. 24: Communication resistor in connection line

1 Transmitter | 2 Power supply unit

If a handheld terminal or a PC is being used for communication / configuration / parameterization in a potentially explosive atmosphere with type of protection "intrinsic safety", the devices used must be certified accordingly.

This applies even if the device is only connected for a short period of time. This proof of "intrinsic safety" must be supplied in addition to the transmitter.

For additional information, refer to the operating instructions included with the handheld terminal.

If the transmitter has been configured in the factory according to customer specifications for the measuring point, all you have to do is mount the transmitter as prescribed (to correct potential zero shifts, refer to the section "Correcting the zero shift"), and switch it on. The measuring point will now be ready for use.

If the transmitter is equipped with an LCD indicator, the current pressure/absolute pressure is displayed in % (factory setting, unless otherwise specified).

If, however, you wish to make changes to the configuration, a handheld terminal or - preferably - a graphical user interface (DTM) is required.

This DTM tool can be used to configure the device fully. It supports the HART protocol and runs on a PC or laptop, i.e., on an automated system.

Refer to the installation manual provided with the software for the steps required to install the operating tool. The most important parameters can be set under the path "Configure_Pressure Measurement".

The program offers the option of configuring, polling, and testing the transmitter. In addition, offline configuration can be performed by means of an internal database. Each configuration step is subject to a plausibility check. You can call up context-sensitive help at any time by pressing the "F1" key.

We recommend that you save the existing configuration data on a separate data storage medium as soon as you receive the transmitter or before you change the configuration. To do this, select: "File_Save".

7.6 Configuration with the graphical user interface (DTM)

7.6.1 System requirements

- Operating control program (e.g., SMART VISION version 4.01 or higher)
 - DTM (Device Type Manager; graphical user interface)
 - Operating system (depending on the respective control program)
1. The DTM is started in 3 stages, either using the right mouse button or via the menu item "Device". First, select "More", followed by "Edit".
 2. When you select "Connect" (the 3rd stage), the full 261Gx / Ax transmitter data should be loaded.

Modified data will be underlined in blue.



IMPORTANT (NOTE)

If modified data is not displayed underlined in blue, click in another window before the data is transferred to the device. The modified value is then displayed underlined in blue.

3. Use "Save to device" to send this data to the device.



IMPORTANT (NOTE)

Saving the data in the transmitter automatically saves it to the non-volatile memory. For this purpose, the transmitter must be supplied with power for two minutes. Failure to observe this will cause the transmitter to revert to the previous data the next time it is used.

The communication name updates automatically when the data is loaded from the device.

The most important configuration/parameterization options in the user interface are briefly listed below. For further information on the menu commands, refer to the context-sensitive help.



IMPORTANT (NOTE)

Before beginning with device setup, make sure that write protection is disabled in the DTM as well as in the LCD indicator.

Menu path

"Configure_Basic Parameter_General"

7.7 Parameter descriptions

Write protection

Enabling/Disabling is performed via the DTM, handheld terminal or LCD indicator.

When "Write Protect" is enabled for the device, HART write protection is set, i.e., it is not possible to configure the device locally or via external tools such as a handheld terminal (HHT). It is, however, possible to read out data.

Write protection can be cancelled by selecting "User data write enabled".

Local operation

Enabling/Disabling is performed via DTM or HHT.

Setup with indicator "Disabled" means that the transmitter cannot be configured using the pushbutton for the lower and upper range values or, if there is an LCD indicator present (optional), that it cannot be configured via the display menu. Once "Local operation" is disabled, it cannot be enabled again on the LCD indicator.

Correcting the zero shift

Menu path

"Configure_Configure Pressure Measurement_Pressure"

Press the "Adjust" button in the "Zero Shift" field.

Calibration is performed immediately and saved to the failsafe memory.

Setting the “Lower Range Value” and “Upper Range Value”

Menu path:
“Configure_Configure Pressure Measurement_Pressure”

The “Scaling” field offers two setting options.

1. Enter value:

Enter the desired values in the input fields "Lower Range Value" and "Upper Range Value".

2. “Apply Process Variable”:

For settings, apply the pressure for the “Lower Range Value” and “Upper Range Value” to the measuring cell.

After the desired stabilized pressure is reached, press either "Set lower Range value" or "Set Upper Range Value". Make sure that the measuring limits are not exceeded.

Reducing stations with adjustable pressure and reference displays can be used as pressure generators. When making the connection, please ensure that there are no residual fluids (for gaseous testing materials) or air bubbles (for fluid testing materials) in the connection lines, since these can lead to errors during inspection.

The possible measuring error of the pressure generator should be at least three times smaller than the desired measuring error of the transmitter.

Adjust damping

Menu path:
“Configure_Configure Pressure Measurement_Pressure”

Enter the desired damping value in the field “Output parameter” in the line “Damping”.

The additional time constant can be set between 0 s and 60 s in increments of 0.0001 s.

Offset

Menu path:
“Configure_Configure Pressure Measurement_Pressure”

This function performs a parallel shift of the characteristic curve so that it travels through a point specified by the user. This makes it possible to set the output signal of several measuring devices that measure the same process variable to the same value without having to perform a calibration with applied pressure.

For further information, see “Offset shift”. Enter the respective new X2 value (in %) in the window “The current measurement value corresponds to”.

Description

Menu path:
"Device_Identification_Device"

A measuring point tag with a maximum length of 16 characters can be entered here. Characters can include uppercase letters, numbers and a few special characters.

Factory reset

Menu path:
“Device_Reset_Reset to factory default”

Restores the transmitter settings to the factory default.

Warm start

Menu path:
“Device_Reset_Warm Start”

The transmitter is restarted with its basic settings. Temporary settings such as “Simulating the current output” or “Diagnostic messages” are reset.



IMPORTANT (NOTE)

This action will briefly interrupt the connection.

8 Ex relevant specifications

8.1 Hazardous atmospheres

8.1.1 ATEX transmitter with type of protection "intrinsic safety Ex ia/ib" in accordance with Directive 94/9/EC

Transmitter with 4 ... 20 mA output signal and HART communication	
Certificate no.	PTB 05 ATEX 2032
Labeling	II 1/2 G Ex ia IIC T4 ... T6 II 2 G Ex ib IIC T4 ... T6

Permissible ambient temperature range according to temperature class:

Ambient temperature	Temperature class
-40 ... 85 °C (-40 ... 185 °F)	T1 ... T4
-40 ... 71 °C (-40 ... 159 °F)	T5
-40 ... 56 °C (-40 ... 132 °F)	T6

or

Labeling	II 1/2 D IP65 T95 °C Ex ia D II 2 D IP65 T95 °C Ex ib D
----------	--

Permissible ambient temperature range:
-40 ... 85 °C (-40 ... 185 °F)

Supply and signal circuit with "Intrinsically safe Ex ia/ib IIB/IIC" type of protection", with the following maximum values

	$U_i = 30 \text{ V}$
	$I_i = 130 \text{ mA}$
	$P_i = 0.8 \text{ W}$
Effective internal capacitance	$C_i = 10 \text{ nF}$
Effective internal inductance	$L_i = 0.5 \text{ mH}$

8.1.2 IECEx transmitter with the following types of protection: "intrinsic safety ia", "non sparking nA" and "dust ignition protection by enclosure tb"

Transmitter with 4 ... 20 mA output signal and HART communication	
Certificate no.	IECEX ZLM 10.0002
Labeling	Ex ia IIC T6 bzw. T4 Ga/Gb Ex ia IIIC T66°C bzw. T95°C Da/Db Ex nA IIC T6 bzw. T4 Gc Ex tb IIIC T66°C bzw. T95°C Db

Maximum permissible ambient temperature range according to temperature class

Ambient temperature	Temperature class	Surface temperature
-40 ... 85 °C (-40 ... 185 °F)	T4	95 °C (203 °F)
-40 ... 56 °C (-40 ... 133 °F)	T6	66 °C (151 °F)

Electrical data according to designation Ex ia IIC T6 or T4 Ga/Gb and Ex ia IIIC T66°C or T95°C IP6X Da/Db

Supply and signal circuit with "intrinsic safety" Ex ia or Ex ib type of protection, for connection to power supply units with the following maximum values (terminal signal ±)

	$U_i = 30 \text{ V}$
	$I_i = 130 \text{ mA}$
	$P_i = 0.8 \text{ W}$
Effective internal capacitance	$C_i = 10 \text{ nF}$
Effective internal inductance	$L_i = 0.5 \text{ mH}$

If the transmitter is being integrated into a partition between equipment protection level Ga or Da and a lower protection level, the transmitter must be supplied with power by an Ex ia intrinsically safe circuit.

Electrical data according to designation Ex nA IIC T6 or T4 Gc and Ex tb IIIC T66°C or T95°C IP6X Db

	$I_N \leq 22,5 \text{ mA}$
	$U_N \leq 45 \text{ V}$

8.1.3 Factory Mutual (FM)

Transmitter with 4 ... 20 mA output signal and HART communication	
Intrinsic Safety	Class I; II and III; Division 1; Groups A, B, C, D; E, F, G Class I; Zone 0; AEx ia Group IIC T6; T4
Non-incendive	Class I, II, III, Division 2; Groups A, B, C, D, F, G
Degree of protection	NEMA type 4X (indoor and outdoor installation)

8.1.4 Canadian Standards Association (CSA)

Transmitter with 4 ... 20 mA output signal and HART communication	
Intrinsic Safety	Class I; II and III; Division 1; Groups A, B, C, D; E, F, G Class I; Zone 0; Group IIC T6; T4
Non-incendive	Class I, II, III; Division 2; Groups A, B, C, D; F, G
Degree of protection	NEMA type 4X (indoor and outdoor installation)

Permissible ambient temperature range according to temperature class:

	U _i max. = 30 V; I _i max = 130 mA; P _i = 0,8 W; C _i = 10 nF; L _i = 0,5 µH		
Ex ia II CT1 ... T6	T6 -40 ... 56 °C	T5 -40 ... 71 °C	T1 ... T4 -40 ... 85 °C

Intrinsic safety	Gas and dust, order code X4
Degree of protection	Ex ia II CT1~T6; DIP A20 T _A 95 °C

8.1.5 NEPSI (China)

Transmitter with 4 ... 20 mA output signal and HART communication	
Intrinsic Safety	(Gas, order code X3)
Designation	Ex ia II CT1~CT6

Permissible ambient temperature range according to temperature class:

	U _i max. = 30 V; I _i max = 130 mA; P _i = 0,8 W; C _i = 10 nF; L _i = 0,5 µH		
Ex ia II CT1 ... T6	T6 -40 ... 56 °C	T5 -40 ... 71 °C	T1 ... T4 -40 ... 85 °C
DIP A20 T _A 95 °C	-40 ... 85 °C		

9 Technical Data

9.1 Functional specifications

9.1.1 Measuring range limits and span limits

Sensor code	Measuring range upper limit (URL)	Measuring range lower limit (LRL) Model 261GS	Minimum measuring span	
			Model 261GS Gauge pressure	Model 261AS Absolute pressure
C	6 kPa 60 mbar 24 inH ₂ O	-6 kPa -60 mbar 24 inH ₂ O	0,3 kPa 3 mbar 1,2 inH ₂ O	0,3 kPa 3 mbar 2,25 mm Hg
F	40 kPa 400 mbar 160 inH ₂ O	-40 kPa -400 mbar -160 inH ₂ O	2 kPa 20 mbar 8 inH ₂ O	2 kPa 20 mbar 15 mm Hg
L	250 kPa 2500 mbar 1000 inH ₂ O	0 abs	12,5 kPa 125 mbar 50 inH ₂ O	12,5 kPa 125 mbar 93,8 mm Hg
D	1000 kPa 10 bar 145 psi	0 abs	50 kPa 500 mbar 7,25 psi	50 kPa 500 mbar 375 mm Hg
U	3000 kPa 30 bar 435 psi	0 abs	150 kPa 1,5 bar 21,7 psi	150 kPa 1,5 bar 21,7 psi
R	10000 kPa 100 bar 1450 psi	0 abs	500 kPa 5 bar 72,5 psi	500 kPa 5 bar 72,5 psi
V	60000 kPa 600 bar 8700 psi	0 abs	3000 kPa 30 bar 435 psi	-

IMPORTANT (NOTE)

The measuring range lower limit (LRL) for model 261AS is absolute 0 for all measuring ranges.

9.1.2 Span limits

Maximum span = measuring range upper limit (URL)

To optimize performance characteristics, it is recommended that you select the transmitter sensor code with the lowest turn down ratio.

TURNDOWN = Upper range limit / set span

9.1.3 Zero suppression and elevation

The zero position and span can be set to any value within the measuring range limits listed in the table if:

- Set span ≥ minimum span

9.1.4 Damping

Configurable time constant between 0 and 60 s.

This is in addition to the sensor response time, and can be adjusted via the optional LCD indicator, handheld terminal, or PC user interface.

9.1.5 Warm-up time

Ready for operation as per specifications in less than 10 s with minimum damping.

9.1.6 Insulation resistance

>100 MΩ at 500 V DC (between terminals and ground).

9.2 Operating limits

9.2.1 Pressure limits

Overpressure limits

No damage will occur during transmitter operation, if they are used within the specifications and subject to the following limits:

Sensor code	Overpressure limits, 0 abs to:
C, F	1 MPa, 10 bar, 145 psi
L	0.5 MPa, 5 bar, 72.5 psi
D	2 MPa, 20 bar, 290 psi
U	6 MPa, 60 bar, 870 psi
R	20 MPa, 200 bar, 2,900 psi
V	90 MPa, 900 bar, 13,050 psi
Perfluoroelastomer gasket T ≥ -15 °C (5 °F)	0.6 MPa abs, 6 bar abs, 87 psia
Perfluoroelastomer gasket T ≥ -25 °C (-13 °F)	0.18 MPa abs, 1.8 bar abs, 26 psia

Test pressure

When carrying out the transmitter pressure test, it is essential to observe the overpressure limits!

9.2.2 Temperature limits °C (°F)

Environment

Model 261GS, 261AS	Ambient temperature limits
Operating temperature range	-40 ... 85 °C (-40 ... 185 °F)
White oil filling	-6 ... 85 °C (21 ... 185 °F)
LCD display	-20 ... 70 °C (-4 ... 158 °F)
Viton seal	-20 ... 85 °C (-4 ... 185 °F)
Perfluoroelastomer gasket (see also "Pressure limits")	-25 or -15 ... 80 °C (-13 or 5 ... 176 °F)

IMPORTANT (NOTE)

For applications in potentially explosive atmospheres, the temperature range specified on the relevant certificate/approval must be observed.

Process

Model 261GS, 261AS	Process temperature limits
Process temperature range	-50 ... 120 °C (-58 ... 248 °F)
White oil filling	-6 ... 120 °C (21 ... 248 °F) ¹
Viton seal	-20 ... 120 °C (-4 ... 248 °F)
Perfluoroelastomer gasket (see also "Pressure limits")	-25 or -15 ... 80 °C (-13 or 5 ... 176 °F)

¹ ≤ 85 °C (185 °F) for operating pressures below the atmospheric pressure

Storage

Model 261GS, 261AS	Storage temperature range
Storage temperature range	-50 ... 85 °C (-58 ... 185 °F)
LCD display	-40 ... 85 °C (-40 ... 185 °F)
White oil filling	-6 ... 85 °C (21 ... 185 °F)

Model 261GS, 261AS	Humidity during storage
Relative humidity	Up to 75 %

9.2.3 Limits for environmental effects

Electromagnetic compatibility (EMC)

The devices conform to the requirements and tests for EMC Directive 2004/108/EC, as well as EN 61000-6-3 concerning emitted interference and EN 61000-6-1, EN 61000-6-2 concerning interference immunity. The devices fulfill NAMUR recommendations.

Low Voltage Directive

The devices meet the requirements of Directive 2006/95/EC.

Pressure Equipment Directive (PED)

The devices meet the requirements of Directive 97/23/EC, Category III, module H.

Humidity

Relative humidity: Up to 100 %
Condensation, icing: Permissible

Vibration resistance

Acceleration up to 2 g at frequencies of up to 1,000 Hz (according to IEC 60068-2-6).

Shock resistance

Acceleration: 50 g
Duration: 11 ms
(according to 60068-2-27)

Humid and dusty atmospheres (degree of protection)

The transmitter is dust and sand-tight, and is protected against immersion effects as defined by the following standards:

- IEC EN60529 (1989) with IP 67 (with IP 68, IP 69K on request)
 - NEMA 4X
 - JIS C0920
- IP65 degree of protection with plug connection

9.3 Measuring accuracy

9.3.1 Reference conditions according to IEC 60770

- Ambient temperature TU = constant in the range 18 ... 30 °C (64 ... 86 °F)
- Relative humidity = constant in the range 30 ... 80 %
- Ambient pressure PU = constant in the range 950 ... 1,060 mbar.
- Measuring span based on zero position
- Transmitter with ceramic or Hastelloy separation diaphragm
- Filling fluid: Silicone oil
- Supply voltage: 24 V DC
- Load with HART: 250 Ω
- Transmitter not grounded
- Characteristic setting: linear, 4 ... 20 mA.

Unless otherwise stated, errors are specified as a % of the measuring span value.

The accuracy of the measurement in relation to the upper range limit (URL) is affected by the turndown (TD); i.e., the ratio of the upper range limit (URL) to the set span (URL/span). FOR OPTIMUM MEASURING ACCURACY, IT IS RECOMMENDED THAT YOU SELECT THE SENSOR CODE WHICH WILL PROVIDE THE LOWEST TD VALUE.

9.3.2 Dynamic response (according to IEC 61298-1)

Reaction time	100 ms
Time constant (63.2 % of total step response)	150 ms

9.3.3 Measuring error for setting cut-off point

Turndown	Measuring error
1:1 ... 10:1	±0.1 %
>10:1	± (0.1 + 0.005 x TD - 0.05) %

9.3.4 Ambient temperature

Thermal change in ambient temperature as regards the zero signal and span (turndown up to 6:1), in relation to the set span

Temperature range	Maximum effect on zero signal and span
-10 ... 60 °C (14 ... 140 °F)	All measuring ranges ± (0.2 % x TD + 0.2 %)
-40 ... -10 °C (-40 ... 14 °F)	All measuring ranges
60 ... 85 °C (140 ... 185 °F)	±((0.1 % / 10 K) x TD + (0.1 / 10K))

9.3.5 Temperature coefficient (T_K)

Effect of the ambient temperature per 10 K (but limited to the maximum effect of the temperature change, see previous information). The information refers to the set measuring span.

Temperature range	Effect on zero signal and span
-10 ... 60 °C (14 ... 140 °F)	Sensor code C, F: ± (0.15 % x TD + 0.15 %)
	Sensor code L, D, U, R, V: ± (0.05 % x TD + 0.05 %)

9.3.6 Power supply

Within the specified limits for the voltage / load, the total influence is less than 0.001 % of the upper measuring range limit per volt.

9.3.7 Load

Within the specified load / voltage limits, the total influence is negligible.

9.3.8 Electromagnetic fields

Total influence is less than 0.3 % of measuring span from 80 ... 1,000 MHz and for field strengths up to 10 V/m when tested with unshielded conduit, with or without meter.

9.3.9 Mounting position

Nominal position: vertical; process connection at bottom.
The filling fluid of the measuring equipment affects the position if the mounting position differs. If the deviation is 90° from the nominal position and silicone oil is used as the filling fluid, this equates to 1.12 mbar + 0.01 mbar/10K.
This effect can be compensated by carrying out zero signal adjustment and configuring the mounting angle with the LCD indicator or DTM.

9.3.10 Long-term stability

±(0.10 x TD) % / year

9.3.11 Vibration effect

±(0.10 x TD) % acc. to IEC 61298-3

9.3.12 Total performance

Similar to DIN 16086

In the range -10 ... 60 °C (14 ... 140 °F):

0.42% of the set span (TD 1:1)

The total performance accuracy includes the measuring error (non-linearity including hysteresis and non-reproducibility), as well as the thermal change in the ambient temperature as regards the zero signal and span.

$$E_{perf} = \sqrt{(E_{\Delta TS1} + E_{\Delta TS2})^2 + E_{lin}^2}$$

E_{perf} = Base accuracy

$E_{\Delta TS1}$ = Effect of the ambient temperature on the URL

$E_{\Delta TS2}$ = Effect of the ambient temperature on the measuring span

E_{lin} = Measuring error (for setting cut-off point)

9.4 Technical specification

(Refer to ordering information sheets for variant availability related to specific model or versions code)

9.4.1 Materials

Process separation diaphragms¹

Ceramic (AL₂O₃) gold-plated, Hastelloy C276,
Hastelloy C276 gold-plated,
Stainless steel (1.4435 / 316L)

Process connection¹

Stainless steel (1.4404 / 316L)

Gasket¹

(for sensor code C,F only)

Viton, perfluoroelastomer, Buna (NBR)

Sensor filling fluid

Silicone oil, inert filling (carbon fluoride), white oil (FDA)

Mounting bracket

Stainless steel

Sensor housing, electronics housing and cover

Stainless steel (1.4404 / 316L)

Filter for atmospheric ventilation

Filter housing: Plastic (standard), stainless steel (code EA, AB)

Filter material: Polyamide (PA)

Viewing window in cover (LCD display)

Polycarbonate, Makrolon 6557

O-ring cover

EPDM

Plates

Plastic data plate attached to the electronics housing

9.4.2 Calibration

Standard:

— 0 to upper range limit (URL)

Optional:

— To specified measuring span

9.4.3 Optional extras

Mounting bracket

For vertical and horizontal 60 mm (2 in.) pipes or wall mounting

LCD display

Can be rotated in 90° increments into 4 positions

Additional tag plates

Code I2: For measuring point tag (up to 30 characters) and calibration specifications (up to 30 characters: lower and upper value plus unit), attached to transmitter housing.

Code I1: For customer data (4 lines with 30 characters each), attached to transmitter housing with wire.

Cleaning stage for oxygen applications (O2)

Certificates (test, design, characteristics, material traceability)

Name plate and operating instruction language

Communication plug connectors

9.4.4 Process connections

1/2-14 NPT female or male thread, DIN EN 837-1 G 1/2 B or G 1/2 B (HP) for convex seal, flush diaphragm, for installation in ball valve.

¹ Transmitter parts that come into contact with fluid

9.4.5 Electrical connections

M16 x 1.5 tap hole with cable gland (cable diameter approx. 5 ... 10 mm), directly on housing

or

M20 x 1.5 (via adapter) with cable gland (cable diameter approx. 6 ... 11 mm)

or

1/2-14 NPT (via adapter) without cable gland

or

Harting Han plug connector (with mating plug (socket outlet, for wire diameters of 0.75 ... 1 mm² and cable diameters of 5 ... 11 mm))

or

Miniature plug connector (without mating plug (socket outlet))

Terminals

HART version:

Two connections for signal/auxiliary power, for wire cross-sections from 0.5 ... 1.5 mm² (16 AWG)

Grounding (optional)

External ground terminals for wire cross-sections up to 4 mm² (12 AWG).

9.4.6 Weight

(without options)

— Approx. 0.7 kg (1.54 lb)

— Additional 650 G (1.5 lb)

9.4.7 Packaging

Carton with dimensions of approx. 240 x 140 x 190 mm (9.45 x 5.51 x 7.48 in.)

9.5 Mounting dimensions
(not design data) - dimensions in mm (inch)
9.5.1 Standard version

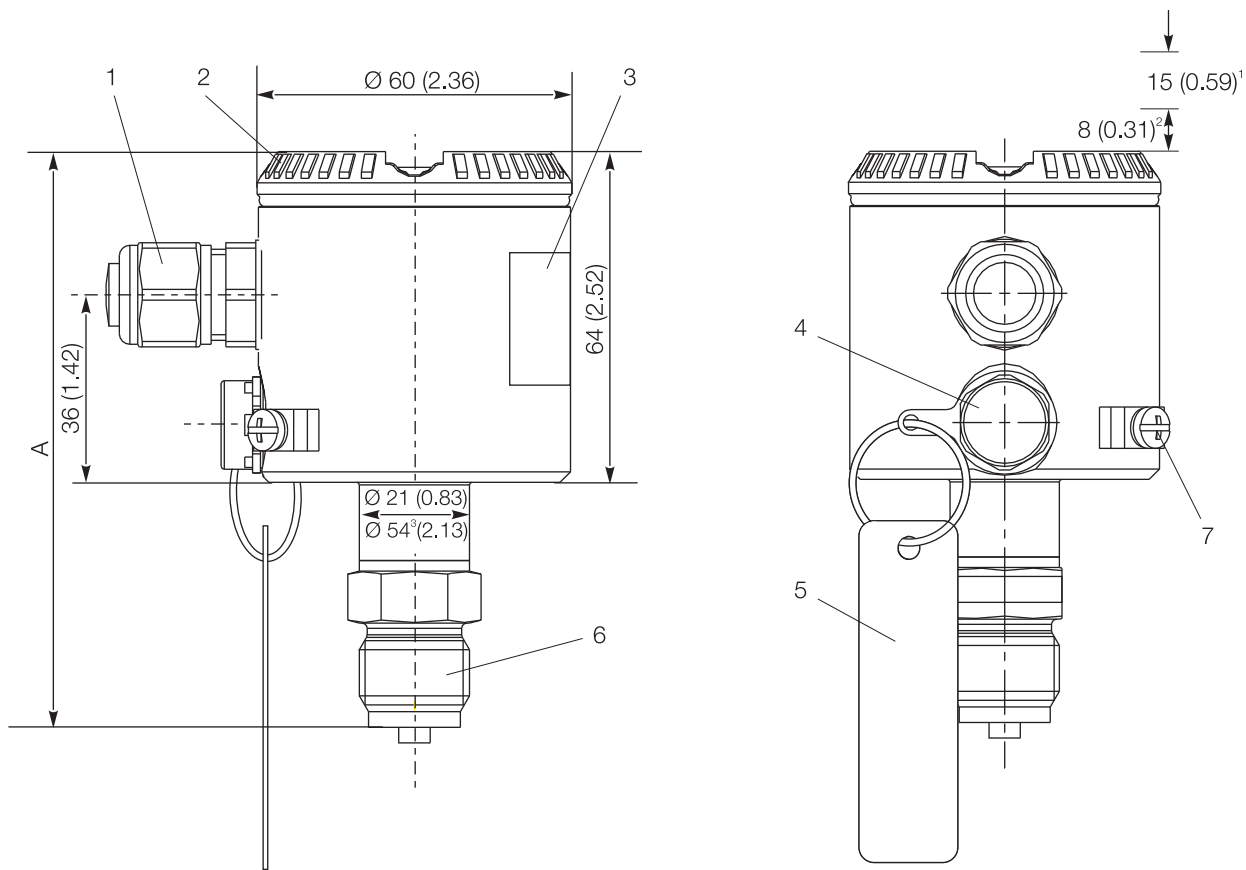

M10684

Fig. 25: Dimensions - Standard version

1 Electrical connection | **2** Housing cover | **3** Name plate | **4** Filter for atmospheric compensation | **5** Tag (optional) | **6** Process connection | **7** Grounding/equipotential bonding terminal (optional)

- 1 Space for removing the cover required
- 2 With LCD indicator
- 3 Dimensions for sensor code C, F with ceramic diaphragm material

Dimension "A" is dependent on the process connection as per the following table:

Process connection	Dimension "A" in mm (inch)
1/2-14 NPT male thread	111 (4.37)
1/2-14 NPT female thread	106 (4.17) / (110 (4.33) sensor V)
DIN EN 837-1 G 1/2 B	111 (4.37)
DIN EN 837-1 G 1/2 B (HP) for connections with convex seal	121 (4.76)

9.5.2 Version with the options “LCD indicator” and “Harting Han plug”

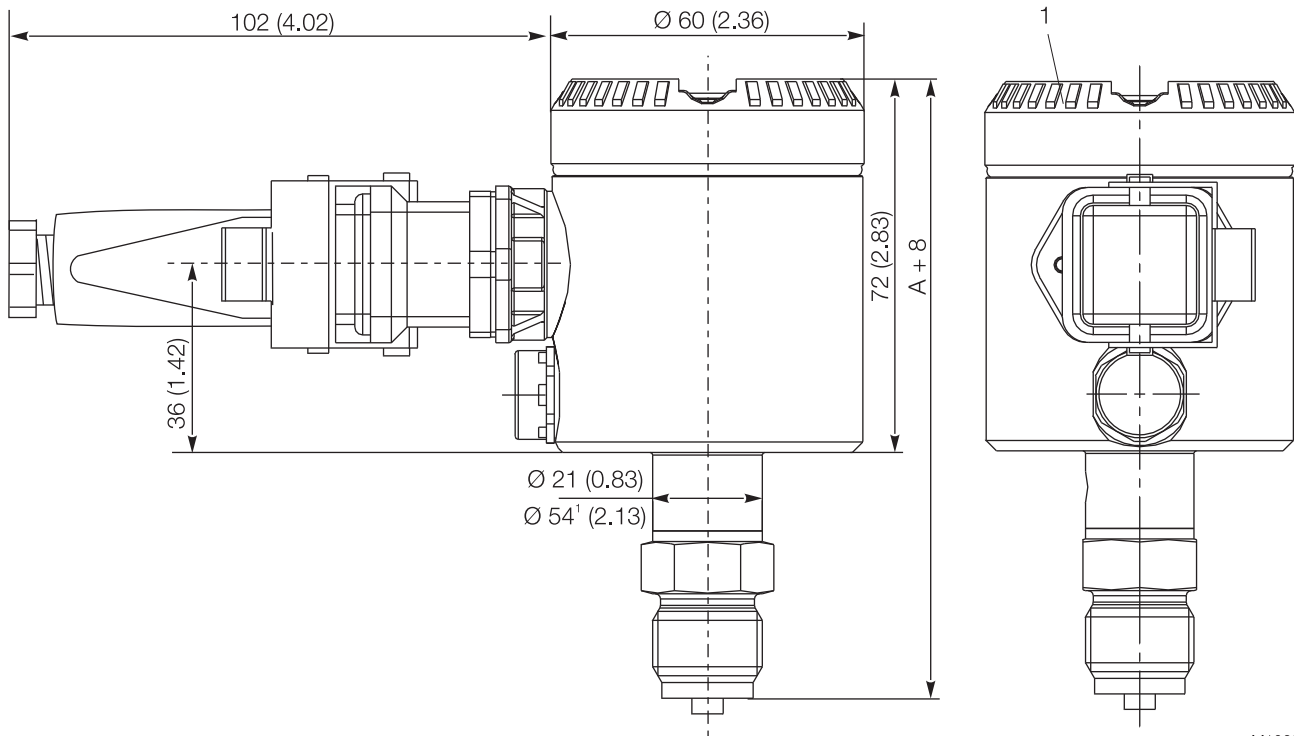

M10685

Fig. 26: Dimensions - With options
1 Housing cover for LCD indicator option

1 Dimensions for sensor code C, F with ceramic diaphragm material

Dimension "A" is dependent on the process connection as per the following table:

Process connection	Dimension "A" in mm (inch)
1/2-14 NPT male thread	111 (4.37)
1/2-14 NPT female thread	106 (4.17) / (110 (4.33) sensor V)
DIN EN 837-1 G 1/2 B	111 (4.37)
DIN EN 837-1 G 1/2 B (HP) for connections with convex seal	121 (4.76)

9.5.3 Transmitter with flush diaphragm

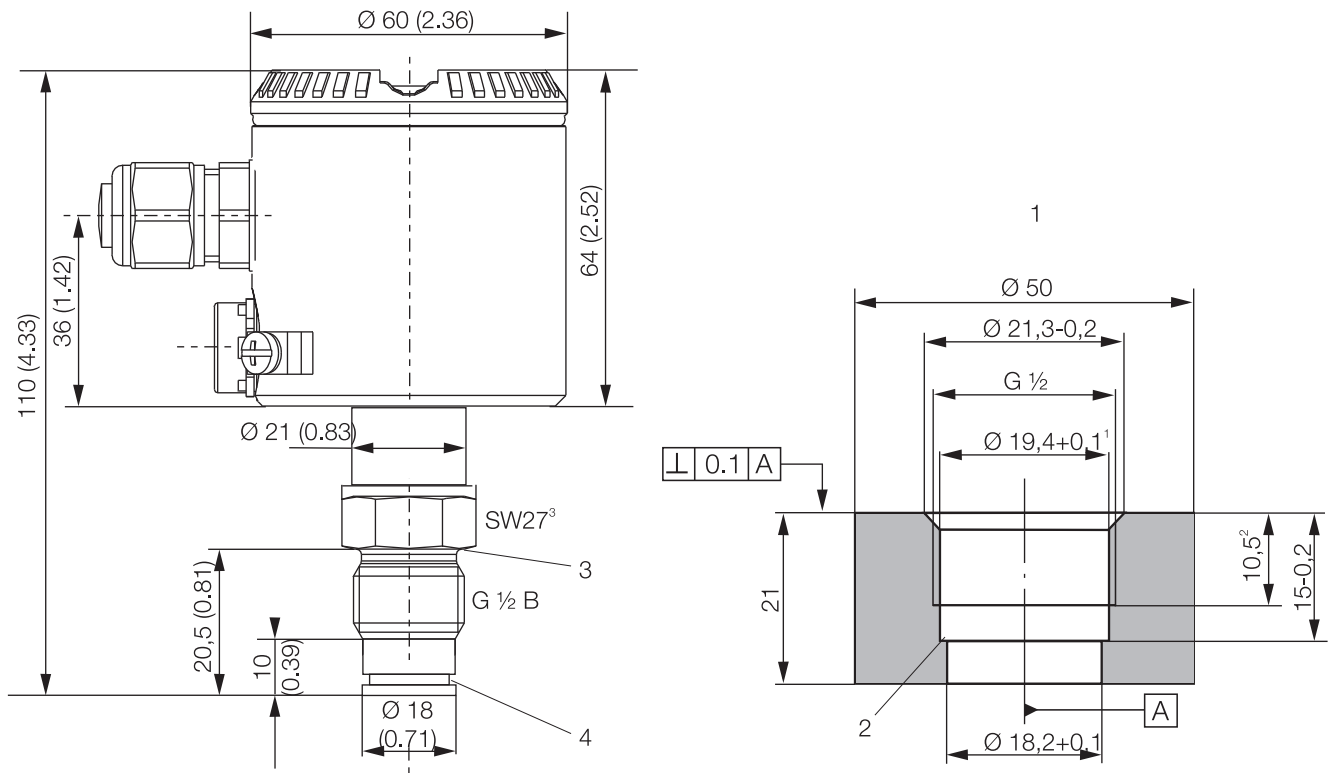

M10686

Fig. 27: Dimensions - With flush diaphragm

- 1 Welded connections / tapped hole for flush diaphragm, part no. 284903 | 2 No burrs |
 3 Groove for gasket DIN 3869 - 21 18.5 x 23.9 x 1.5 | 4 Groove for O-ring 15 x 2

- 1 Bevel after cutting threads
 2 Minimum dimension
 3 Wrench size 27

9.5.4 Version with ball valve connection

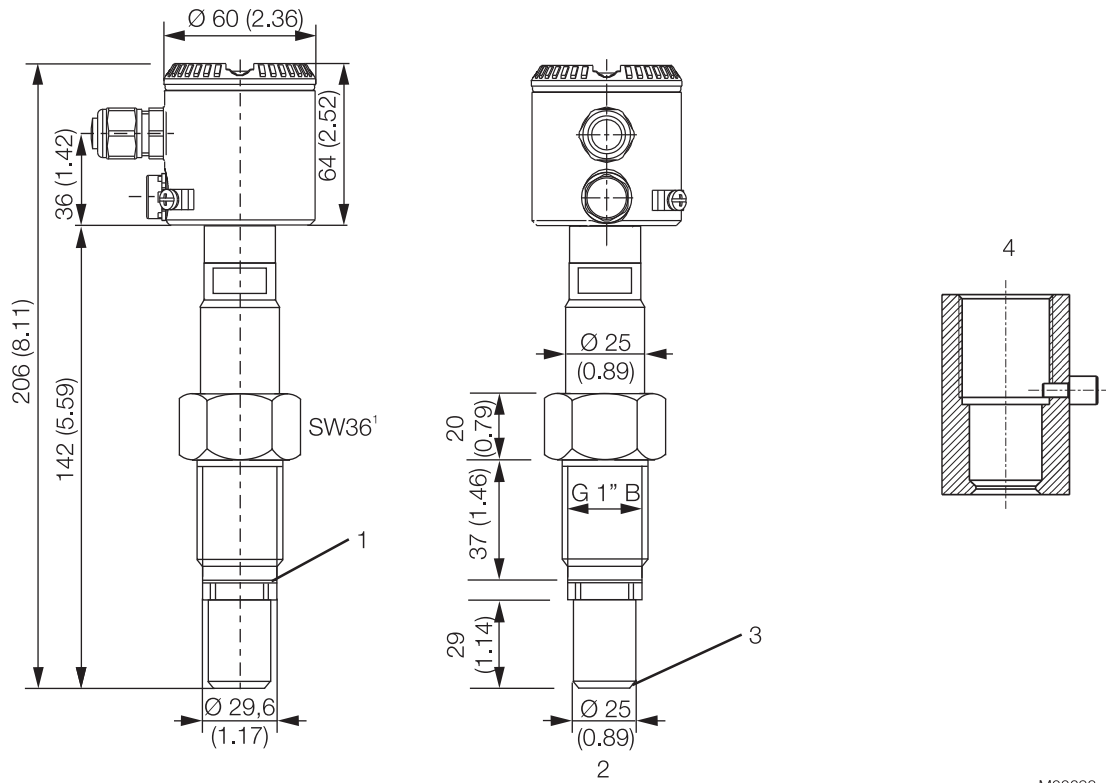

Fig. 28: Dimensions - With ball valve connection

1 Shim | 2 Diaphragm diameter: ~ 20 mm (0.79 inch) | 3 metal / metal conical seal, diaphragm is process-bonded | 4 Weld-in sleeve G 1", part no.: 789516

1 Wrench size 36

M00698

9.5.5 Mounting with angle bracket (optional)

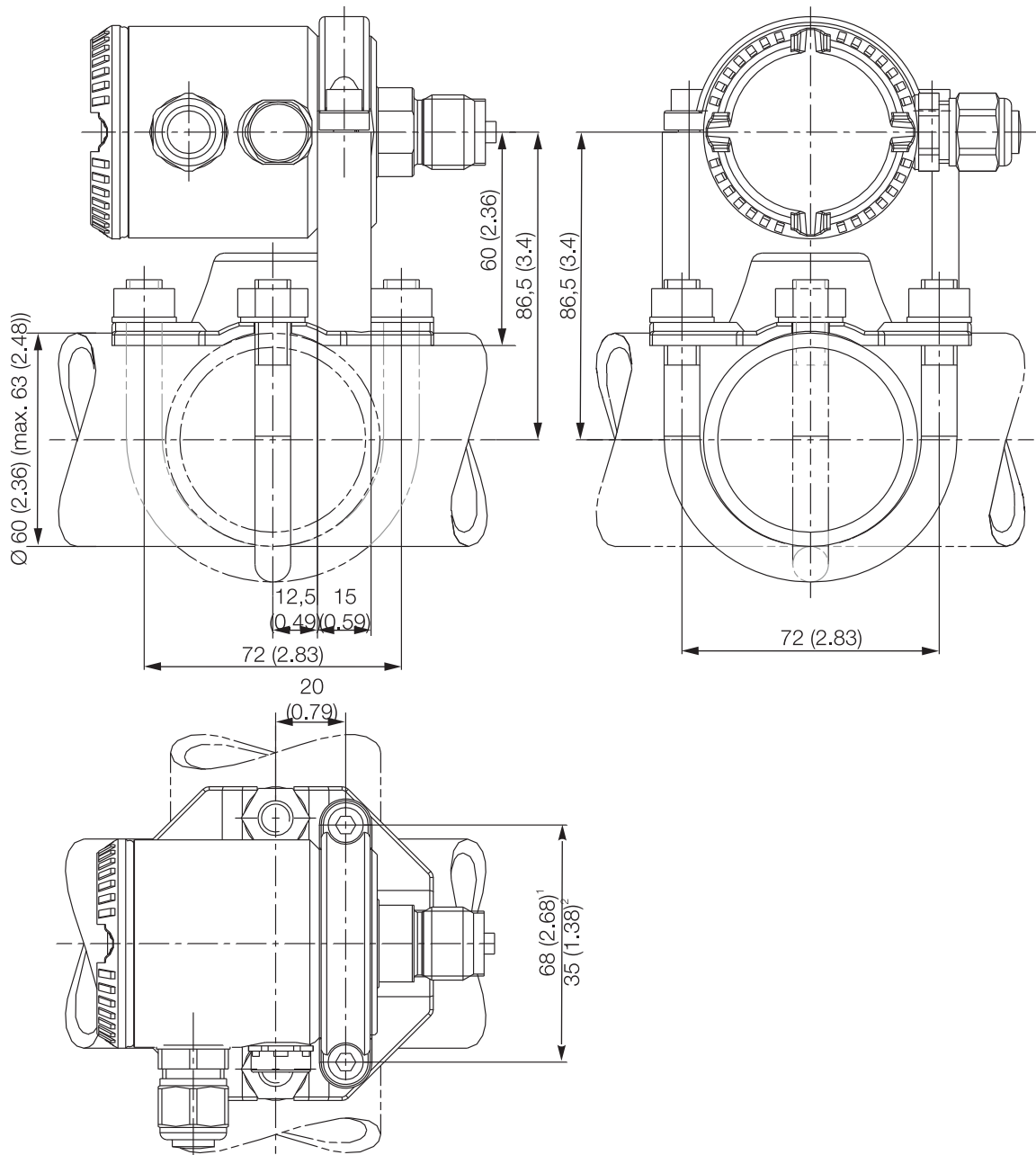

Fig. 29: Dimensions - Pipe / wall mounting

- 1 Dimensions for sensor code C, F with ceramic diaphragm material
- 2 Sensor code C, F, L, D, U, 1, R, V with metal diaphragms

IMPORTANT (NOTE)

The bracket for wall or pipe mounting has four holes with a \varnothing of 10.5 mm. The holes are arranged in a square and spaced 72 mm away from one another.

M10688

10 Maintenance / Repair



WARNING – Bodily injury

The device can be operated at high pressure and with aggressive media. Any medium that squirts out can cause severe injuries. Depressurize the pipeline/tank before opening the transmitter connection.



NOTICE – Potential damage to device as a result of electrostatic charging!

When the housing is open, EMC protection is impaired and there is no longer any protection against accidental contact. Do not touch conductive parts of the device.

10.1 Removal



WARNING – Potential danger if device is disassembled incorrectly!

Before removing or disassembling the device, check for hazardous process conditions such as pressure on the device, high temperatures, aggressive or toxic media, and so on. Carefully read the instructions in the sections "Safety", "Mounting", and "Electrical connections", and perform the specified steps in reverse order.

Corrective maintenance work may only be performed by trained personnel.

Before removing the device, depressurize it and any adjacent lines or containers.

Check whether hazardous materials have been used as materials to be measured before opening the device. Residual amounts of hazardous material may still be present in the device and could escape when it is opened.

Within the scope of operator responsibility, check the following as part of a regular inspection:

- the pressure-carrying walls / lining of the pressure device
- the measurement-related function
- the leak tightness
- the wear (corrosion)

If pressure transmitters are used as intended under normal operating conditions, no maintenance is required.

It is sufficient to check the output signal at regular intervals (in accordance with the operating conditions), as described in the instructions in the section "Operation". If deposits are expected to accumulate, the measuring equipment should be cleaned on a regular basis, in accordance with the operating conditions.

Cleaning should ideally be carried out in a workshop.

11 Appendix

11.1 Approvals and certifications



The version of the device as provided by us meets the requirements of the following EU directives:

- EMC Directive 2004/108/EC
- Low Voltage Directive 2006/95/EC
- Pressure Equipment Directive (PED) 97/23/EC

Explosion protection

Designation relating to intended use in potentially explosive atmospheres in compliance with:



- ATEX Directive



IMPORTANT (NOTE)

All documentation, declarations of conformity, and certificates are available in ABB's download area.
www.abb.com/pressure



EG-KONFORMITÄTSERKLÄRUNG

EC DECLARATION OF CONFORMITY
ATTESTATION DE CONFORMITE C.E.

Hersteller: ABB Automation Products GmbH
Manufacturer / Fabricant: **Minden**

Anschrift: Schillerstraße 72
Address / Adresse: **D-32425 Minden**

Produktbezeichnung: Druck-Messumformer - 261A, 261G
Product name: Pressure Transmitter – 261A, 261G
Désignation du produit: Transmetteur de Pression – 261A, 261G

Das Produkt stimmt mit den Vorschriften folgender Europäischer Richtlinien überein:

*This product meets the requirements of the following European directives:
Les produits répondent aux exigences des Directives C.E. suivantes:*

2004/108/EG 2004/108/EC 2004/108/CE	EMV-Richtlinie * <i>Electromagnetic Compatibility Directive *</i> <i>Directives concernant la compatibilité électromagnétique *</i>	
2006/95/EG 2006/95/EC 2006/95/CE	Niederspannungsrichtlinie * <i>EC-Low-Voltage Directive *</i> <i>Directives concernant la basse tension *</i>	
97/23/EG 97/23/EEC 97/23/C.E.E.	Druckgeräterichtlinie, Kategorie III Modul H <i>Pressure Equipment Directive, Category III Module H</i> <i>Directive Equipements sous Pression, Catégorie III Module H</i>	(für Druck PS > 200bar) <i>(for pressure PS > 200 bar)</i> <i>(pour pression PS > 200 bar)</i>

Druck/Pressure/Pression PS ≤ 200bar: SEP

CE 0045

Für Geräte in Ex-Ausführung gemäß Kennzeichnung auf Typschild gilt zusätzlich:

*For products in Ex design according to identification on nameplate the following is additionally applicable:
Pour des produits en exécution Ex selon marque sur plaque signalétique le suivant est aussi applicable:*



94/9/EG 94/9/EEC 94/9/C.E.E.	ATEX-Richtlinie <i>ATEX Directive</i> <i>ATEX Directive</i>
---	--

* einschließlich Änderungen und deutscher Umsetzung durch das EMVG und Gerätesicherheitsgesetz
 * including alterations and German realization by the EMC law and the instruments safety law
 * y compris les modifications et la réalisation allemande par la loi cocernant la compatibilité électromagnétique et la sécurité d'appareils

Die Übereinstimmung mit den Vorschriften dieser Richtlinien wird nachgewiesen durch die vollständige Einhaltung folgender Normen:

*Conformity with the requirements of these Directives is proven by complete adherence to the following standards:
La conformité avec les exigences de ces directives est prouvée par l'observation complète des normes suivantes:*

EN 61 000-6-1 / EN 61 000-6-2 / EN 61 000-6-3 / EN 61 000-6-4 / EN 61 010-1

Ex: Es gelten die Normen der entsprechenden EG-Baumusterprüfbescheinigungen

*The standards of the relevant type-examination certificates shall apply
Il convient d'appliquer les normes des certificats d'homologation CE*

02.07.2009

Datum
Date
Date

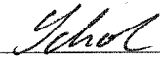
 Dr. Wolfgang Scholz
 Leiter R&D
 Head of R&D
 Responsable R&D

 Bernhard Kruse
 Leiter Qualitätsmanagement
 Head of Quality Management
 Responsable Assurance de la Qualité

EG-Konformität_261_07.2009.doc

Contact us

ABB Ltd.

Process Automation

Howard Road, St. Neots
Cambridgeshire, PE19 8EU
UK

Tel: +44 (0)1480 475321

Fax: +44 (0)1480 217948

ABB Inc.

Process Automation

125 E. County Line Road
Warminster PA 18974
USA

Tel: +1 215 674 6000

Fax: +1 215 674 7183

ABB Automation Products GmbH

Process Automation

Schillerstr. 72
32425 Minden
Germany

Tel: +49 551 905-534

Fax: +49 551 905-555

www.abb.com

Note

We reserve the right to make technical changes or modify the contents of this document without prior notice. With regard to purchase orders, the agreed particulars shall prevail. ABB does not accept any responsibility whatsoever for potential errors or possible lack of information in this document.

We reserve all rights in this document and in the subject matter and illustrations contained therein. Any reproduction, disclosure to third parties or utilization of its contents in whole or in parts – is forbidden without prior written consent of ABB.

Copyright© 2011 ABB

All rights reserved

3KXP200001R4201

IM/261Gx/Ax-EN Rev. 06.08.2011