

# Model 266GST Gauge Model 266AST Absolute

## 2600T series pressure transmitters

Engineered solutions for all applications



### Base accuracy

- 0.04 % of calibrated span (optional 0.025 %)

### Proven sensor technology together with state-of-the-art digital technology

- Large turn down ratio of up to 100:1

### Comprehensive selection of sensors

- Optimized performance and stability

### 10-year stability

- 0.15 % of URL

### Flexible configuration options

- Local configuration via keys on LCD indicator

### New TTG (through-the-glass) key technology

- Enables quick and easy local configuration without the need to open the cover - even in environments with explosion protection

### IEC 61508 certification

- For SIL2 (1oo1) and SIL3 (1oo2) applications

### Full compliance with Pressure Equipment Directive (PED) category III

# Model 266GST Gauge

## Model 266AST Absolute

### Functional specification

#### Measuring range limits and span limits

Sensor code	Upper range limit (URL)	Lower range limit (LRL) 266GST (Δ)	Minimum measuring span	
			266GST	266AST
C	6 kPa 60 mbar 24 inH <sub>2</sub> O	-6 kPa -60 mbar -24 inH <sub>2</sub> O	0.2 kPa 2 mbar 0.8 inH <sub>2</sub> O	0.3 kPa 3 mbar 2.25 mmHg
F	40 kPa 400 mbar 160 inH <sub>2</sub> O	-40 kPa -400 mbar -160 inH <sub>2</sub> O	0.4 kPa 4 mbar 1.6 inH <sub>2</sub> O	2 kPa 20 mbar 15 mmHg
L	250 kPa 2,500 mbar 1,000 inH <sub>2</sub> O	0 abs	2.5 kPa 25 mbar 10 inH <sub>2</sub> O	12.5 kPa 125 mbar 93.8 mmHg
D	1,000 kPa 10 bar 145 psi	0 abs	10 kPa 100 mbar 1.45 psi	50 kPa 500 mbar 7.25 psi
U	3,000 kPa 30 bar 435 psi	0 abs	30 kPa 0.3 bar 4.35 psi	150 kPa 1.5 bar 21.7 psi
R	10,000 kPa 100 bar 1,450 psi	0 abs	100 kPa 1 bar 14.5 psi	500 kPa 5 bar 72.6 psi
V	60,000 kPa 600 bar 8,700 psi	0 abs	600 kPa 6 bar 87 psi	-

(Δ) Measuring range lower limit (LRL) for 266AST is 0 abs for all measuring ranges

#### Span limits

Maximum span = URL

For optimum measuring accuracy, it is recommended that you select the sensor code which will provide the lowest TD value.

#### Zero position suppression and elevation

The zero position and span can be set to any value within the measuring range limits listed in the table if:

- Set span ≥ minimum span

#### Damping

Configurable time constant between 0 and 60 s.

This is in addition to the sensor response time.

#### Warm-up time

Ready for operation as per specifications in less than 10 s with minimum damping.

#### Insulation resistance

>100 MΩ at 500 V DC (between terminals and ground).

## Operating limits

### Pressure limits

#### Gauge pressure limits

Without damage to the transmitter

Sensors	Gauge pressure limits
Sensor C, F	0 absolute and 1 MPa, 10 bar, 145 psi
Sensor L	0 absolute and 0.5 MPa, 5 bar, 72.5 psi
Sensor D	0 absolute and 2 MPa, 20 bar, 290 psi
Sensor U	0 absolute and 6 MPa, 60 bar, 870 psi
Sensor R	0 absolute and 20 MPa, 200 bar, 2,900 psi
Sensor V	0 absolute and 90 MPa, 900 bar, 13,050 psi
Perfluoroelastomer gasket	0 absolute and 0.6 MPa abs, 6 bar abs, 87 psia T ≥ -15 °C (5 °F) 0.18 MPa abs, 1.8 bar abs, 26 psia T ≥ -25 °C (-13 °F)

### Test pressure

The transmitter can be subjected to a line pressure up to the following values without leakage:

Sensors	Gauge pressure limits
Sensor C, F	0 absolute and 1 MPa, 10 bar, 145 psi
Sensor L	0 absolute and 0.5 MPa, 5 bar, 72.5 psi
Sensor D	0 absolute and 2 MPa, 20 bar, 290 psi
Sensor U	0 absolute and 6 MPa, 60 bar, 870 psi
Sensor R	0 absolute and 20 MPa, 200 bar, 2,900 psi
Sensor V	0 absolute and 90 MPa, 900 bar, 13,050 psi
Perfluoroelastomer gasket	0 absolute and 0.6 MPa abs, 6 bar abs, 87 psia T ≥ -15 °C (5 °F) 0.18 MPa abs, 1.8 bar abs, 26 psia T ≥ -25 °C (-13 °F)

Meets hydrostatic test requirements of ANSI/ISA-S 82.03.

# Model 266GST Gauge

## Model 266AST Absolute

### Temperature limits °C (°F)

#### Environment

This is the operating temperature

Models 266GST, 266AST	Ambient temperature limits
Silicone oil	-40 ... 85 °C (-40 ... 185 °F)
Fluorocarbon (Galden)	-40 ... 85 °C (-40 ... 185 °F)
White oil	-6 ... 85 °C (21 ... 185°F)

#### Important

For applications in explosive environments, the temperature range specified on the certificate / approval applies dependent upon the degree of protection sought.

Models 266GST, 266AST	Ambient temperature limits
Integrated LCD display	-40 ... 85 °C (-40 ... 185 °F)
Viton gasket	-20 ... 85 °C (-4 ... 185 °F)
Perfluoroelastomer gasket	-25 or -15 ... 80 °C (-13 or 5 ... 176 °F) See the section titled "Pressure limits".

Below -20 °C (-4 °F) and above 70 °C (158 °F), it may no longer be possible to read the LCD display clearly.

### Process

Models 266GST, 266AST	Process temperature limits
Silicone oil	-50 ... 121 °C (-58 ... 250 °F)
Fluorocarbon (Galden)	-40 ... 121 °C <sup>1</sup> (-40 ... 250 °F)
White oil	-6 ... 121 °C (21 ... 250 °F)
Viton gasket	-20 ... 121 °C (-4 ... 250 °F)
Perfluoroelastomer gasket	-25 or -15 ... 80 °C (-13 or 5 ... 176°F) See the section titled "Pressure limits".

<sup>1</sup> ≤ 85 °C (185 °F) for operating pressures below the atmospheric pressure

### Storage

Models 266GST, 266AST	Storage temperature range
Storage temperature	-50 ... 85 °C (-58 ... 185 °F)
Integrated LCD display	-40 ... 85 °C (-40 ... 185 °F)
White oil	-6 ... 85 °C (21 ... 185 °F)

## Limits for environmental effects

### Electromagnetic compatibility (EMC)

Meets requirements of EN 61326 and Namur NE-21

Overvoltage strength (with surge protection): 4 kV (in acc. with IEC 1000-4-5 EN 61000-4-5)

### Pressure Equipment Directive (PED)

Meets requirements of Directive 97/23/EC Category III, module H.

### Humidity

Relative humidity: Up to 100 %.

Condensation, icing: Permissible.

### Vibration resistance

Acceleration up to 2 g at frequencies of up to 1,000 Hz (according to IEC 60068-2-6).

### Shock resistance

Acceleration: 50 g

Duration: 11 ms

(according to IEC 60068-2-27).

### Humid and dusty atmospheres (degree of protection)

The transmitter is dust and sand-proof and protected against immersion effects as defined by EN 60529 (1989) to IP 67 (IP 68 on request), by NEMA to 4X, or by JIS C0920. IP 65 with Harting Han plug connector.

## Hazardous atmospheres

With or without integral LCD display

---

"Intrinsic Safety" type of protection:

Approval acc. to ATEX Europa (code E1) and IEC Ex (code E8)

II 1 G Ex ia IIC T6/T5/T4 and

II 1/2 G Ex ia IIC T6/T5/T4; IP67.

II 1 D Ex iaD 20 T85 °C and

II 1/2 D Ex iaD 21 T85 °C; IP67.

NEPSI China (Code EY)

Ex ia IIC T4~ T6, DIP A20TA, T4~T6.

---

"Flameproof Enclosure" type of protection:

Approval acc. to ATEX Europa (code E2) and IEC Ex (code E9)

II 1/2 G Ex d IIC T6 and

II 1/2 D Ex tD A21 T85 °C (-50 °C ≤ Ta ≤ +75 °C); IP67.

NEPSI China (Code EZ)

Ex d IIC T6, DIP A21TA, T6.

---

"nL" type of protection:

ATEX Europa (code E3) and IEC Ex (code ER)

Declaration of conformity

II 3 G Ex nL IIC T6/T5/T4 and

II 3 D Ex tD A22 T85 °C; IP67.

NEPSI China (code EY) declaration of conformity

Ex nL IIC T4~ T6, DIP A22TA, T6.

---

FM approvals for USA (code E6) and

FM approvals for Canada (code E4):

- Explosionproof (US): Class I, Div. 1, Groups A, B, C, D
  - Explosionproof (Canada): Class I, Div. 1, Groups B, C, D
  - Dust ignitionproof : Class II, Div. 1, Groups E, F, G
  - Suitable for: Class II, Div. 2, Groups F, G; Class III, Div. 1, 2
  - Nonincendive: Class I, Div. 2, Groups A, B, C, D
  - Intrinsically safe: Class I, II, III, Div. 1, Groups A, B, C, D, E, F, G  
Class I, Zone 0 AEx ia IIC T6/T4, Zone 0 (FM US)  
Class I, Zone 0 Ex ia IIC T6/T4, Zone 0 (FM Canada)
- 

ATEX combined (code EW = E1 + E2 + E3), (code E7 = E1 + E2)

ATEX combined and FM approvals (code EN = EW + E4 + E6)

---

Combined FM approvals for USA and Canada

- Intrinsic safety (code EA)
  - Flameproof enclosure (code EB)
  - Non-incendive (code EC)
- 

IEC combined (code EH = E8 + E9), (code EI = E8 + E9 + ER)

NEPSI combined (code EP = EY + EZ), (code EQ = EY + EZ + ES)

---

– GOST (Russia), GOST (Kazakhstan), Inmetro (Brazil) based on ATEX

---

The permissible ambient temperature ranges (within the limits of -50 and 85 °C) are specified in the type examination certificates dependent upon the temperature class.

# Model 266GST Gauge

## Model 266AST Absolute

### Electrical data and options

#### HART digital communication and 4 ... 20 mA output

##### Power supply

The transmitter operates from 10.5 ... 42 V DC with no load and is protected against reversed polarity (additional loads enable operation above 42 V DC).

During use in Ex ia zones and in other intrinsically safe applications, the power supply must not exceed 30 V DC. Minimum operating voltage with "surge protection" option: 12.3 V DC

##### Ripple

Max. 20 mV over a 250 Ω load as per HART specifications.

##### Load limitations

Total loop resistance at 4 ... 20 mA and HART:

$$R \text{ (k}\Omega\text{)} = \frac{\text{Voltage supply} - \text{Minimum operating voltage (V DC)}}{22 \text{ mA}}$$

A minimum resistance of 250 Ω is required for HART communication.

##### Displays (optional)

###### Integrated LCD display (code L1)

Widescreen LCD display, 128 x 64 pixels, 52.5 x 27.2 mm (2.06 x 1.07 in.) dot matrix. Multilanguage. Four keys for device configuration and management. Easy setup for quick commissioning. Customized visualizations which the user can select. Totalized and actual value flow indication. The display can also be used to show static pressure, sensor temperature, and diagnostics messages, as well as make configuration settings.

###### Integrated LCD display with TTG operation (code L5)

As with the integrated LCD display above, but featuring an innovative TTG (through-the-glass) keypad which can be used to activate the device's configuration and management menus without having to remove the transmitter housing cover. The TTG keys are protected against accidental activation.

##### Surge protection (optional)

Up to 4 kV

- Voltage: 1.2 μs rise time / 50 μs delay time at half value
- Current: 8 μs rise time / 20 μs delay time at half value

##### Output signal

Two-wire output 4 ... 20 mA, can be selected by user: linear or linearization table with 22 points (e.g., for level measurements in horizontal, cylindrical containers or spherical vessels).

HART communication provides digital process variables superimposed on the 4 ... 20 mA signal (protocol according to Bell 202 FSK standard).

##### Output current limits (according to NAMUR standard)

Overload condition

- Lower limit: 3.8 mA (configurable from 3.8 ... 4 mA)
- Upper limit: 20.5 mA (configurable from 20 ... 21 mA)

##### Alarm current

- Minimum alarm current: 3.6 mA (configurable from 3.6 ... 4 mA)
- Maximum alarm current: 21 mA (configurable from 20 ... 22 mA)

Default setting: High Alarm Current

## FOUNDATION fieldbus output

### Model

LINK MASTER

Link Active Scheduler (LAS) capability implemented.

Manufacturer code: 000320 (hex)

Device type code: 0007 (hex)

### Power supply

The transmitter operates from 9 ... 32 V DC, regardless of polarity, with or without surge protection.

During use in EEx ia zones, the power supply must not exceed 24 V DC (entity certification) or 17.5 V DC (FISCO certification) according to FF-816.

### Current consumption

Operating (quiescent): 15 mA

Fault current limit value: 20 mA max.

### Output signal

Physical layer in accordance with IEC 11582 / EN 611582; transmission using Manchester II modulation at 31.25 kbit/s.

### Function blocks / cycle time

- 3 enhanced analog input blocks / 25 ms max. (each)
- 1 extended PID block / 40 ms max.
- 1 standard arithmetic block / 25 ms
- 1 standard input selector block / 25 ms
- 1 standard control selector block / 25 ms
- 1 standard signal characterization block / 25 ms
- 1 standard integrator / totalizer block / 25 ms

### Additional blocks

- 1 enhanced resource block
- 1 manufacturer-specific pressure with calibration transducer block
- 1 manufacturer-specific advanced diagnostics transducer block
- 1 manufacturer-specific local display transducer block

### Number of link objects

35

### Number of VCRs

35

## Output interface

FOUNDATION fieldbus digital communication protocol in accordance with standard H1; complies with specification V. 1.7.

FF registration in progress.

## Integrated LCD display

Widescreen LCD display, 128 x 64 pixels, 52.5 x 27.2 mm (2.06 x 1.07 in.) dot matrix. Multilanguage.

Four keys for device configuration and management.

Easy setup for quick commissioning.

Customized visualizations which the user can select.

The display can also be used to show sensor temperature and diagnostics messages, as well as make configuration settings.

## Transmitter interference mode

The output signal is "frozen" at the last valid value in the event of significant transmitter interference, once this interference is detected by the self-diagnostics function (which also displays error states).

In the event of electronics failures or short circuits, the transmitter consumption is electronically limited to a defined value (approx. 20 mA) in order to ensure network safety.

# Model 266GST Gauge

## Model 266AST Absolute

### PROFIBUS PA output

#### Model

Pressure transmitter, compliant with Profile 3.0.1  
ID number: 3450 (hex)

#### Power supply

The transmitter operates from 9 ... 32 V DC, regardless of polarity, with or without surge protection.  
The power supply must not exceed 17.5 V DC when used in EEx ia zones.  
Intrinsically safe installation in accordance with FISCO model.

#### Current consumption

Operating (quiescent): 15 mA  
Fault current limit value: 20 mA max.

#### Output signal

Physical layer in accordance with IEC 1158 2 / EN 61158-2;  
transmission using Manchester II modulation at 31.25 kbit/s.

#### Output interface

PROFIBUS PA communication according to  
PROFIBUS DP 50170 Part 2 / DIN 19245 Part 1-3.

#### Output cycle time

25 ms

#### Data blocks

- 1 "physical block"
- 3 "analog input" blocks
- 1 "pressure transducer block" with calibration
- 1 "transducer block" for local display

### Integrated LCD display

Widescreen LCD display, 128 x 64 pixels,  
52.5 x 27.2 mm (2.06 x 1.07 in.) dot matrix. Multilanguage.  
Four keys for device configuration and management.  
Easy setup for quick commissioning.  
Customized visualizations which the user can select.  
The display can also be used to show sensor temperature and diagnostics messages, as well as make configuration settings.

### Transmitter interference mode

In the event of significant transmitter interference that is detected by the self-diagnostics function, the output signal can be put into defined states that the user is able to select: safe value, last valid value, or calculated value.  
In the event of electronics failures or short circuits, the transmitter consumption is electronically limited to a defined value (approx. 20 mA) in order to ensure network safety.

## Measuring accuracy

Reference conditions according to IEC 60770.

Ambient temperature 20 °C (68 °F), rel. humidity 65 %, atmospheric pressure 1,013 hPa (1,013 mbar), measuring span based on zero position, separation diaphragms made from ceramic, stainless steel AISI 316 L, or Hastelloy, silicone oil filling fluid, HART digital trim values equal to 4 and 20 mA span end points, linear characteristic.

Unless otherwise stated, errors are specified as a % of the span value.

Some measuring accuracy levels relating to the upper measuring range limit (URL) are affected by the current turn down (TD); i.e., the ratio of the upper measuring range limit to the set span.

FOR OPTIMUM MEASURING ACCURACY, IT IS RECOMMENDED THAT YOU SELECT THE SENSOR CODE WHICH WILL PROVIDE THE LOWEST TD VALUE.

### Dynamic response (according to IEC 61298-1)

Sensors	Time constant (63.2 % of total step response)
Sensor C to V (all)	150 ms
Reaction time for all sensors	40 ms

Response time (total) = reaction time + time constant

### Measuring error

% of calibrated span, consisting of terminal-based non-linearity, hysteresis, and non-repeatability.

In the case of fieldbus devices, SPAN refers to the analog input function block output scale range.

Model	Sensor	For TD range	
266GST	C to V	From 1:1 to 10:1	±0.04 %
	C	From 10:1 to 30:1	±(0.04 + 0.005 x TD - 0.05) %
	F to V	From 10:1 to 100:1	±(0.04 + 0.005 x TD - 0.05) %
	L to R	From 1:1 to 10:1	±0.025 % (optional)
266AST	C to R	From 1:1 to 10:1	±0.04 %
	C to R	From 10:1 to 20:1	±(0.04 + 0.005 x TD - 0.05) %

### Ambient temperature

Per 20 K change within the limits of -40 to 85 °C (per 36 °F change within the limits of -40 to 185 °F):

Model	Sensor	For TD range	
266GST	C and F	10:1	±(0.06 % URL + 0.09 % span)
266GST	L to V	10:1	±(0.03 % URL + 0.045 % span)
266AST	C and F	10:1	±(0.06 % URL + 0.09 % span)
266AST	L to R	10:1	±(0.03 % URL + 0.045 % span)

In the case of an ambient temperature change between -10 and 60 °C (14 and 140 °F):

Model	Sensor	For TD range	
266GST	C and F	10:1	±(0.08 % URL + 0.08 % span)
266GST	L to V	10:1	±(0.06 % URL + 0.06 % span)
266AST	C and F	10:1	±(0.2 % URL + 0.1 % span)
266AST	L to R	10:1	±(0.06 % URL + 0.06 % span)

Per 10 K change within the limits of -40 to -10 °C or 60 to 85 °C

(per 18 °F change within the limits of -40 to 14 °F or 140 to 185 °F):

Model	Sensor	For TD range	
266GST	C and F	10:1	±(0.04 % URL + 0.05 % span)
266GST	L to V	10:1	±(0.03 % URL + 0.045 % span)
266AST	C and F	10:1	±(0.1 % URL + 0.05 % span)
266AST	L to R	10:1	±(0.03 % URL + 0.045 % span)

# Model 266GST Gauge

# Model 266AST Absolute

## Power supply

Within the specified limits for the voltage / load, the total influence is less than 0.005 % of the upper measuring range limit per volt.

## Load

Within the specified load / voltage limits, the total influence is negligible.

## Electromagnetic field

Meets all requirements of EN 61326 and NAMUR NE-21.

## Common-mode interference

No influence from 100 V rms @ 50 Hz, or 50 V DC

## Mounting position

The recommended mounting position is vertical, with the process connection pointing downward. Any deviations from this position will lead to a zero error, which can be corrected by adjusting the zero position. With measuring range codes C and F, a deviation of 90° has an additional effect on the ambient temperature of up to 0.02 mbar/10K.

## Long-term stability

± 0.15 % of URL over a period of 10 years  
(± 0.05 % URL/year)

## Total performance

Similar to DIN 16086

Temperature change in the range -10 to 60 °C (14 to 140 °F)

Model	Sensor	For TD	Total performance (with 0.04 % measuring error)
266GST	L to V	1:1	± 0.126 % of calibrated span
266AST	L to R	1:1	± 0.126 % of calibrated span

The total performance accuracy includes the measuring error (non-linearity including hysteresis and non-reproducibility), as well as the thermal change in the ambient temperature as regards the zero signal and span.

$$E_{perf} = \sqrt{(E_{\Delta TZ} + E_{\Delta TS})^2 + E_{lin}^2}$$

$E_{perf}$  = Total performance

$E_{\Delta TZ}$  = Effect of the ambient temperature on the zero signal

$E_{\Delta TS}$  = Effect of the ambient temperature on the measuring span

$E_{lin}$  = Measuring error

## Technical specification

(Please refer to the order information to check the availability of different versions of the relevant model)

### Materials

#### Process separation diaphragms<sup>1</sup>

Ceramic (Al<sub>2</sub>O<sub>3</sub>), gold-plated; Hastelloy C276;  
Hastelloy C276, gold-plated; stainless steel AISI 316L (1.4435)

#### Process connection<sup>1</sup>

Stainless steel AISI 316L (1.4404), Hastelloy C276

#### Gasket (only for sensor codes C, F)<sup>1</sup>

Viton, perfluoroelastomer, Buna (NBR)

#### Sensor filling fluid

Silicone oil; fluorocarbon (Galden); white oil (FDA)

#### Mounting bracket<sup>2</sup>

Barrel version:

Galvanized C steel with chromium passivation;  
Stainless steel AISI 316L (1.4404)

DIN version:

AISI 304 (1.4301)

#### Sensor housing

Stainless steel AISI 316L (1.4404)

#### Electronics housing and cover

Aluminum alloy (copper content ≤ 0.3 %) with baked epoxy finish (color: RAL 9002); stainless steel AISI 316L.

#### O-ring cover

Buna N

#### Local zero position, measuring span, and write protection settings

Fiber glass-reinforced polyphenylene oxide (removable)

### Plates

Stainless steel (AISI 316) for transmitter name plate, certification plate, optional measuring point tag plate / settings plate attached to electronics housing, and optional tag plate with customer data. All plates laser-labeled.

### Calibrate

Standard:

— 0 to measuring range upper limit, for ambient temperature and atmospheric pressure

Optional:

— To specified measuring span

<sup>1</sup> Transmitter parts that come into contact with fluid

<sup>2</sup> U-bolt material: stainless steel AISI 400;  
screw material: high-strength alloy steel or stainless steel AISI 316

### Optional extras

#### Mounting bracket

For 60 mm (2 in.) pipes or wall mounting

#### LCD display

Can be rotated in 90° increments into 4 positions

#### Additional tag plates

Code I2: For measuring point tag (up to 30 characters) and calibration specifications (up to 30 characters: lower and upper value plus unit), attached to transmitter housing.

Code I1: For customer data (4 lines with 30 characters each), wired to transmitter housing

#### Surge protector

#### Cleaning stage for oxygen applications (O2)

#### Test certificates (test, design, characteristics, material traceability)

#### Name plate and operating instruction language

#### Communication plug connectors

# Model 266GST Gauge

## Model 266AST Absolute

### Process connections

1/2 – 14 NPT internal or external thread;  
DIN EN 837-1 G 1/2 B or G 1/2 B (HP) for convex seals; flush diaphragm; for ball valve

### Electrical connections

Two 1/2-14 NPT or M20 x 1.5 threaded bores for cable glands, directly on housing.  
Special communication connector (on request)  
— HART: Straight or angled Harting Han 8D connector and one mating plug.  
— FOUNDATION fieldbus, PROFIBUS PA: M12 x 1 or 7/8 in. plug

### Terminals

HART version: Three connections for signal / external display, for wire cross sections of up to 2.5 mm<sup>2</sup> (14 AWG), and connection points for testing and communication purposes  
Fieldbus versions: Two signal connections (bus connection) for wire cross sections of up to 2.5 mm<sup>2</sup> (14 AWG)

### Grounding

Internal and external ground terminals are provided for 6 mm<sup>2</sup> (10 AWG) wire cross sections.

### Mounting position

The transmitters can be installed in any position.  
The electronic housing can be rotated into any position. A stop is provided to prevent overturning.

### Weight

Approx. 2 kg (4.4 lb); additional 1.5 kg (3.3 lb) for stainless steel housing.  
Add 650 g (1.5 lb) for packaging.

### Packaging

Carton with dimensions of 25 x 20 x 14 cm, approx. (10 x 8 x 6 in.)

## Configuration

### Transmitter with HART communication and 4 ... 20 mA Standard configuration

Transmitters are calibrated at the factory to the customer's specified measuring range. The calibrated range and measuring point number are provided on the name plate. If this data has not been specified, the transmitter will be delivered with the plate left blank and the following configuration:

Physical unit	kPa
4 mA	Zero
20 mA	Measuring range upper limit (URL)
Output	Linear
Damping	1 s
Transmitter interference mode	High alarm
Software tag (max. 8 characters)	Blank
Optional LCD display	PV in kPa; output in mA and in percent as bargraph

Any or all of the configurable parameters listed above - including the lower and upper range values (with the same unit of measurement) - can easily be changed using a portable HART handheld communicator or a PC running the configuration software with the DTM for 266 models. Specifications concerning the flange type and materials, O-ring and vent / drain valve materials, and additional device options are stored in the transmitter database.

### Customer-specific configuration (option N6)

The following information can be specified in addition to the standard configuration parameters:

Description	16 alphanumeric characters
Supplementary information	32 alphanumeric characters
Date	Day, month, year

For the HART protocol, the following physical units are available for pressure measurements:

Pa, kPa, MPa  
inH<sub>2</sub>O @ 4 °C, mmH<sub>2</sub>O @ 4 °C, psi  
inH<sub>2</sub>O @ 20 °C, ftH<sub>2</sub>O @ 20 °C, mmH<sub>2</sub>O @ 20 °C  
inHg, mmHg, Torr  
g/cm<sup>2</sup>, kg/cm<sup>2</sup>, atm  
mbar, bar

These and others are available for PROFIBUS and FOUNDATION fieldbus.

### Transmitter with PROFIBUS PA communication Standard configuration

Transmitters are calibrated at the factory to the customer's specified measuring range. The calibrated range and measuring point number are provided on the name plate. If this data has not been specified, the transmitter will be delivered with the plate left blank and the following configuration:

Measuring profile	Pressure
Physical unit	kPa
Output scale 0 %	Measuring range lower limit (LRL)
Output scale 100 %	Measuring range upper limit (URL)
Output	Linear
Upper alarm limit	Measuring range upper limit (URL)
Upper warning limit	Measuring range upper limit (URL)
Lower warning limit	Measuring range lower limit (LRL)
Lower alarm limit	Measuring range lower limit (LRL)
Hysteresis limit value	0.5 % of output scaling
PV filter time	0 s
Address (set using local control buttons)	126
Measuring point tag	30 alphanumeric characters
Optional LCD display	PV in kPa; output in percent as bargraph display

Any or all of the configurable parameters listed above - including the measuring range values (with the same unit of measurement) - can easily be changed using a PC running the configuration software with the DTM for 266 models. Specifications concerning the flange type and materials, O-ring and vent / drain valve materials, and additional device options are stored in the transmitter database.

### Customer-specific configuration (option N6)

The following information can be specified in addition to the standard configuration parameters:

Description	32 alphanumeric characters
Supplementary information	32 alphanumeric characters
Date	Day, month, year

# Model 266GST Gauge

## Model 266AST Absolute

### Transmitter with FOUNDATION fieldbus communication

#### Standard configuration

Transmitters are calibrated at the factory to the customer's specified measuring range. The calibrated range and measuring point number are provided on the name plate. If this data has not been specified, the transmitter will be delivered with the plate left blank and the analog input function block FB1 will be configured as follows:

Measuring profile	Pressure
Physical unit	kPa
Output scale 0 %	Measuring range lower limit (LRL)
Output scale 100 %	Measuring range upper limit (URL)
Output	Linear
Upper alarm limit	Measuring range upper limit (URL)
Upper warning limit	Measuring range upper limit (URL)
Lower warning limit	Measuring range lower limit (LRL)
Lower alarm limit	Measuring range lower limit (LRL)
Hysteresis limit value	0.5 % of output scaling
PV filter time	0 s
Measuring point tag	30 alphanumeric characters
Optional LCD display	PV in kPa; output in percent as bargraph display

The analog input function blocks FB2 and FB3 are each configured for the sensor temperature measured in °C and the static pressure measured in MPa. Any or all of the configurable parameters listed above - including the measuring range values - can easily be changed using a FOUNDATION fieldbus-compatible configuration tool. Specifications concerning the flange type and materials, O-ring and vent / drain valve materials, and additional device options are stored in the transmitter database.

#### Customer-specific configuration (option N6)

The following information can be specified in addition to the standard configuration parameters:

Description	32 alphanumeric characters
Supplementary information	32 alphanumeric characters
Date	Day, month, year

## Mounting dimensions

(not design data) - dimensions in mm (inch)

Transmitter with barrel housing – 1/2 NPT female thread

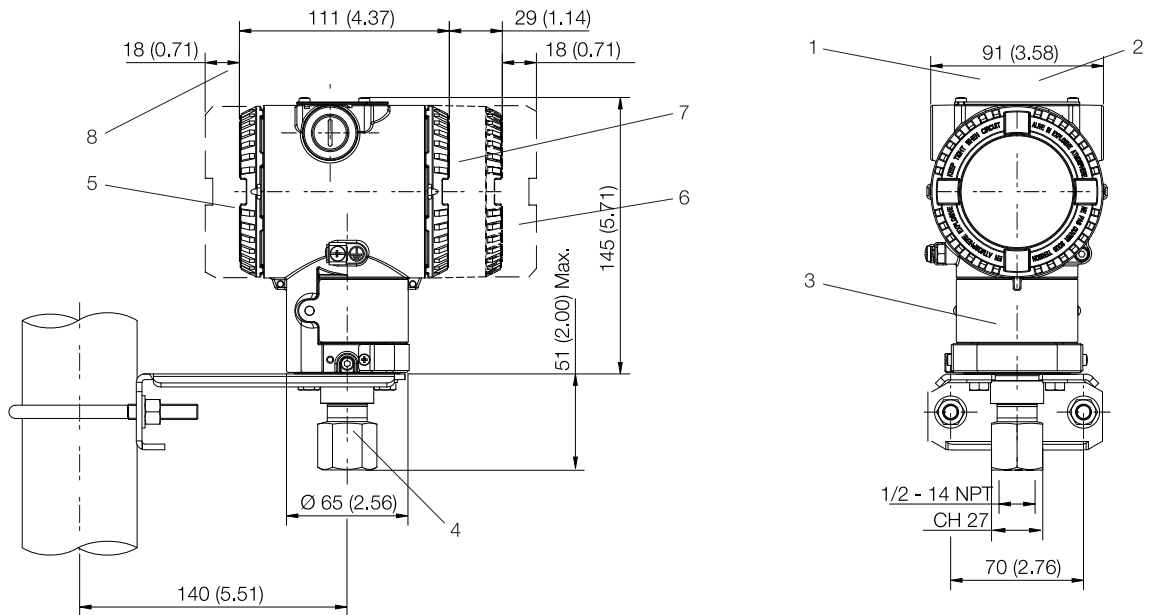

M10025

Fig. 1: Dimensions - Barrel housing – 1/2 NPT female thread

1 Settings | 2 Name plate | 3 Certification plate | 4 Process connection | 5 Terminal side | 6 LCD display housing cover | 7 Electronics side | 8 Space for removing the cover

# Model 266GST Gauge Model 266AST Absolute

## Transmitter with DIN aluminum housing – 1/2 NPT external thread

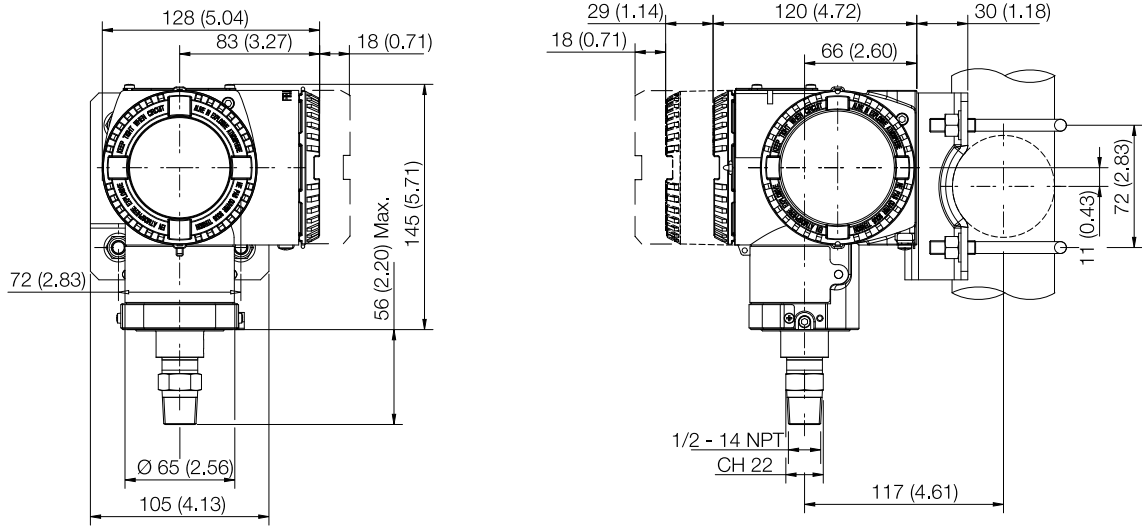

M10026

Fig. 2: Dimensions - DIN aluminum housing – 1/2 NPT external thread

## Transmitter with barrel housing – DIN-EN837-1 G 1/2 B connection

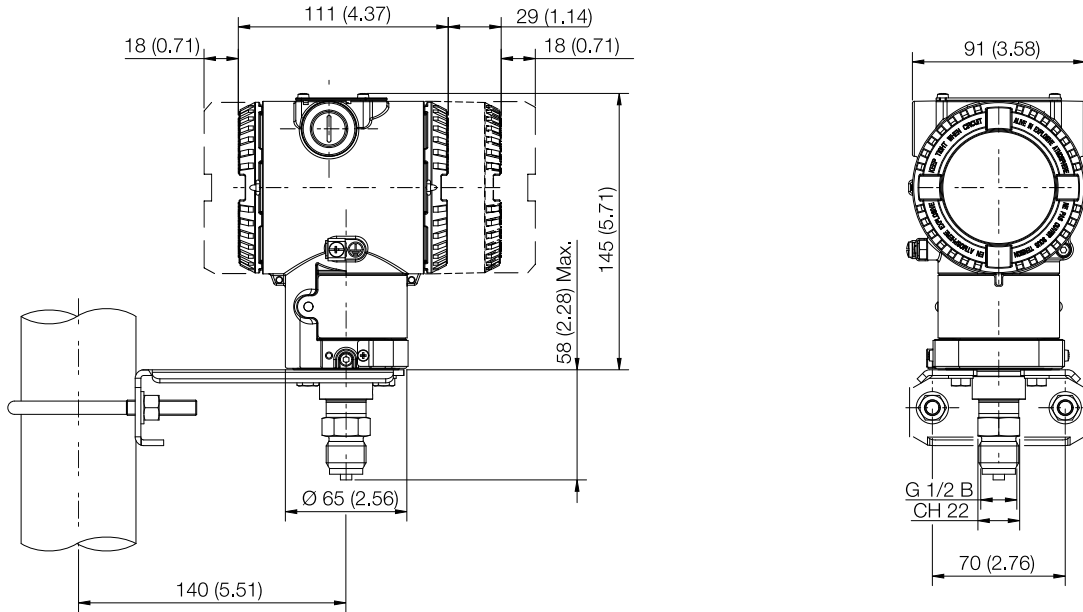

M10027

Fig. 3: Dimensions - Barrel housing – DIN-EN837-1 G 1/2 B connection

## Electrical connections

### HART version

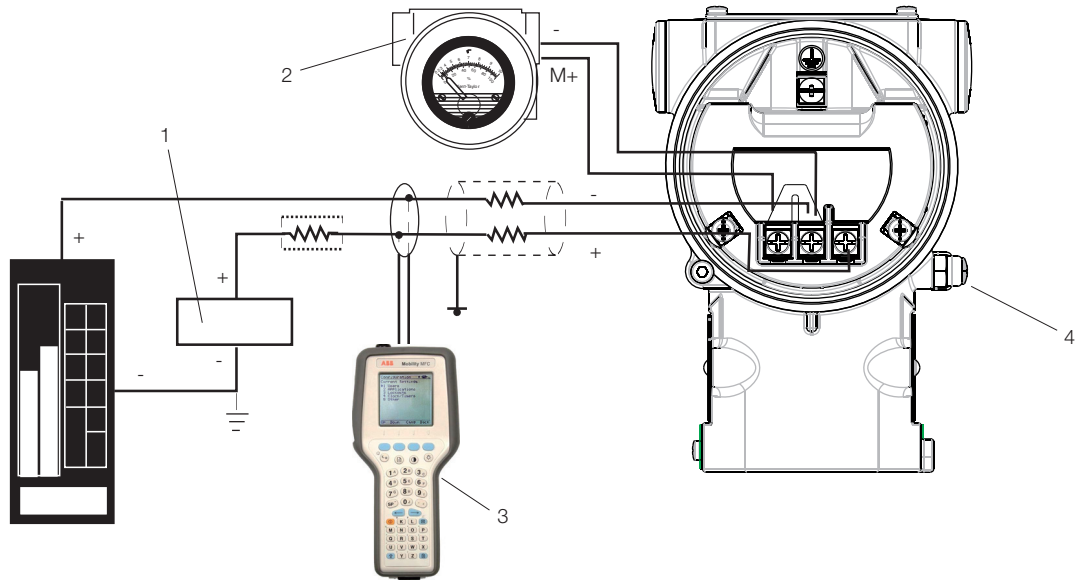

M10023

**Fig. 4: Electrical connections - HART version**

**1 Power supply | 2 Remote display | 3 Handheld terminal | 4 External ground connection**

The HART handheld terminal can be connected to any wiring termination point in the loop, provided there is a minimum resistance of  $250\ \Omega$  between the handheld terminal and transmitter power supply. If this is less than  $250\ \Omega$ , additional resistance needs to be incorporated in order to enable communication.

# Model 266GST Gauge

# Model 266AST Absolute

## Fieldbus versions



Fig. 5: Plug connector - fieldbus versions

Pin assignment (plug)		
Pin number	FOUNDATION fieldbus	PROFIBUS PA
1	DATA -	DATA +
2	DATA +	GROUND
3	SHIELD	DATA -
4	GROUND	SHIELD

Delivery scope: Plug connectors supplied loose without mating plug (female connector)

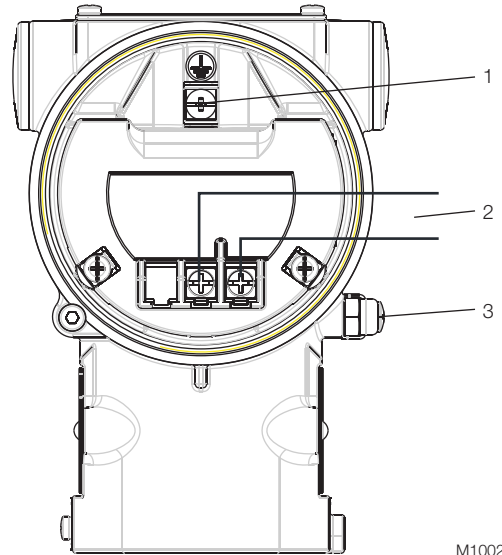

Fig. 6: Standard terminal strip  
1 Internal ground terminal | 2 Fieldbus line (regardless of polarity) | 3 External ground terminal

## HART version

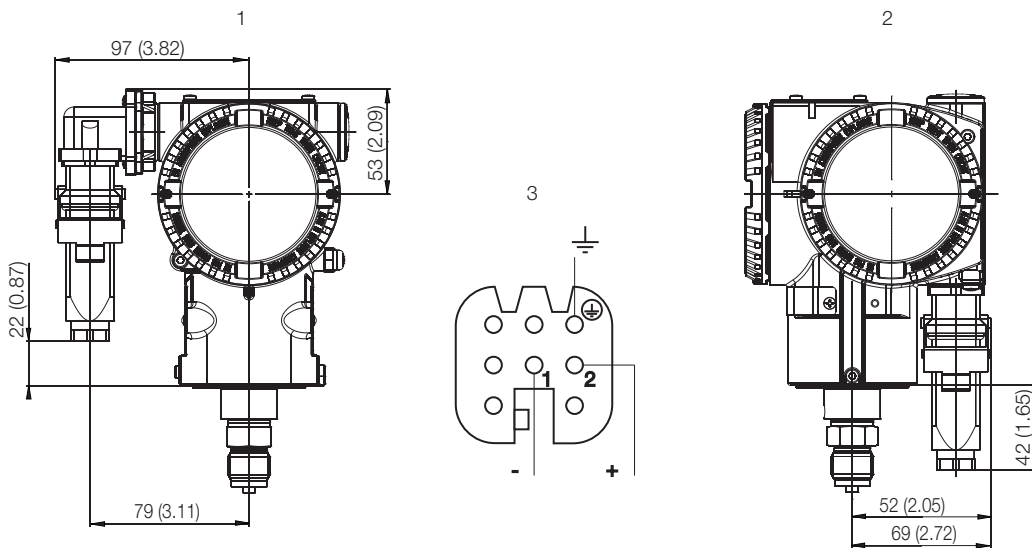

Fig. 7: Harting Han connection - HART version

1 Barrel housing | 2 DIN housing | 3 Harting Han 8D (8U) socket insert for mating plug supplied (view of sockets)

## Ordering information

### Basic ordering information model 266GST Gauge Pressure Transmitter

Select one character or set of characters from each category and specify complete catalog number.

Refer to additional ordering information and specify one or more codes for each transmitter if additional options are required.

Base model – 1 <sup>st</sup> to 6 <sup>th</sup> characters			266GST	X	X	X	X	X	X
Gauge pressure transmitter – base accuracy 0.04 %									
<b>Sensor Span Limits / Overpressure</b> – 7 <sup>th</sup> character									
0.2 and 6 kPa	(2 and 60 mbar, 0.8 and 24 inH <sub>2</sub> O)	1 MPa (10 bar, 145 psi)		C					
0.4 and 40 kPa	(4 and 400 mbar, 1.6 and 160 in. H <sub>2</sub> O)	1 MPa (10 bar, 145 psi)		F					
2.5 and 250 kPa	(25 and 2500 mbar, 10 and 1000 in. H <sub>2</sub> O)	0.5 MPa (5 bar, 72.5 psi)		L					
10 and 1000 kPa	(0.1 and 10 bar, 1.45 and 145 psi)	2 MPa (20 bar, 290 psi)		D					
30 and 3000 kPa	(0.3 and 30 bar, 4.35 and 435 psi)	6 MPa (60 bar, 870 psi)		U					
100 and 10000 kPa	(1 and 100 bar, 14.5 and 1450 psi)	20 MPa (200 bar, 2900 psi)		R					
600 and 60000 kPa	(6 and 600 bar, 87 and 8700 psi)	90 MPa (900 bar, 13050 psi)		V					
<b>Diaphragm Material / Fill Fluid</b> – 8 <sup>th</sup> character									
AISI 316L SST (1.4435)	Silicone oil (Only available with front bonded diaphragm)	NACE							
Hastelloy C-276	Silicone oil (NACE)								
AISI 316L SST	Inert fluid - Galden								
(Only available with front bonded diaphragm / suitable for oxygen applications)									
Hastelloy C-276	Inert fluid - Galden (Suitable for oxygen applications)	NACE							
Hastelloy C-276 gold-plated	Silicone oil	NACE							
Hastelloy C-276 gold-plated	Inert fluid - Galden (Suitable for oxygen applications)	NACE							
AISI 316L SST	White oil (FDA) (Only available with front bonded diaphragm)	NACE							
Hastelloy C-276	White oil (FDA)	NACE							
Ceramic	No filling	NACE	(Note: 1)						
<b>Process Connection Material / Type</b> – 9 <sup>th</sup> character									
AISI 316L SST (1.4404)	1/2-14 NPT female	NACE							
AISI 316L SST (1.4404)	DIN EN 837-1 G 1/2 B	NACE							
AISI 316L SST (1.4404)	G 1/2 in. front bonded diaphragm	NACE							
AISI 316L SST (1.4404)	1/2-14 NPT male	NACE							
AISI 316L SST (1.4404)	DIN EN 837-1 G 1/2 B (HP)	NACE							
AISI 316L SST (1.4404)	For ball valve connection	NACE							
Hastelloy C-276	1/2-14 NPT female	NACE							
Hastelloy C-276	DIN EN 837-1 G 1/2 B	NACE							
Hastelloy C-276	1/2-14 NPT male	NACE							

continued  
see next page

# Model 266GST Gauge

## Model 266AST Absolute

Basic ordering information model 266GST Gauge Pressure Transmitter			X	X	X
<b>Gasket – 10<sup>th</sup> character</b>					
Viton		(Note: 2)	5		
Perfluorelastomere (max. 0.6 MPa / 6 bar / 87 psi)		(Note: 1)	6		
Perbunan (NBR)		(Note: 1)	8		
None			N		
<b>Housing material / Electrical connection– 11<sup>th</sup> character</b>					
Aluminium alloy (Barrel type)	1/2-14 NPT				A
Aluminium alloy (Barrel type)	M20 x 1.5				B
Aluminium alloy (Barrel type)	Harting Han connector (General purpose only)	(Note: 3)			E
Aluminium alloy (Barrel type)	Fieldbus connector (General purpose only)	(Note: 3)			G
AISI 316L SST (Barrel type)	1/2-14 NPT				S
AISI 316L SST (Barrel type)	M20 x 1.5				T
Aluminium alloy (DIN type)	M20 x 1.5				J
Aluminium alloy (DIN type)	Harting Han connector (General purpose only)	(Note: 3)			K
Aluminium alloy (DIN type)	Fieldbus connector (General purpose only)	(Note: 3)			W
AISI 316L SST (Barrel type)	Fieldbus connector (General purpose only)	(Note: 3)			Z
<b>Output – 12<sup>th</sup> character</b>					
HART digital communication and 4 ... 20 mA (No additional options)					H
HART digital communication and 4 ... 20 mA (Options requested by "Additional ordering code")					1
PROFIBUS PA (No additional options)					P
PROFIBUS PA (Options requested by "Additional ordering code")					2
FOUNDATION Fieldbus (No additional options)					F
FOUNDATION Fieldbus (Options requested by "Additional ordering code")					3
HART digital communication and 4 ... 20 mA, SIL2 and SIL3 certified to IEC 61508 (No additional options)					T
HART digital communication and 4 ... 20 mA, SIL2 and SIL3 certified to IEC 61508 (Options requested by "Additional ordering code")					8

### Additional ordering information for model 266GST

Add one or more 2-digit code(s) after the basic ordering information to select all required options.

	XX	XX	XX	XX
<b>Accuracy</b>				
Base accuracy 0.025 % (Note: 4)	D1			
<b>Explosion protection</b>				
ATEX Group II Category 1 GD - Intrinsic Safety Ex ia (Note: 5)		E1		
ATEX Group II Category 1/2 GD - Flameproof Ex d (Note: 6)		E2		
ATEX Group II Category 3 GD - Type of protection "N" Ex nL design compliance (Note: 5)		E3		
FM approval (Canada, CSA) Class I, II, Div. 1, 2, Group A to F (XP, IS, NI) (Only available with 1/2-14 NPT or M20 electrical connections) (Note: 6)		E4		
FM approval (USA) Class I, II, Div. 1, 2, Group A to F (XP, IS, NI) (Only available with 1/2-14 NPT or M20 electrical connections) (Note: 6)		E6		
Combined ATEX Ex ia and Ex d (Note: 6)		E7		
FM approvals (USA and Canada) Intrinsic Safety (Note: 5)		EA		
FM approvals (USA and Canada) Explosion-proof (Note: 6)		EB		
FM approvals (USA and Canada) Non-incendive (Note: 5)		EC		
Combined ATEX, FM and CSA (Only available with 1/2-14 NPT or M20 electrical connections) (Note: 6)		EN		
Combined ATEX - Intrinsic Safety, Flameproof and Type „N“ (Note: 6)		EW		
IEC Approval Group II Category 1 GD - Intrinsic Safety Ex ia (Note: 5)		E8		
IEC Approval Group II Category 1/2 GD - Flameproof Ex d (Note: 6)		E9		
IEC Approval Group II Category 3 GD - Type of protection "N" Ex nL design compliance (Note: 5)		ER		
Combined IEC Approval Ex ia and Ex d (Note: 6)		EH		
Combined IEC Approval Ex ia, Ex d and Ex nL (Note: 6)		EI		
NEPSI IIC Ex ia (Note: 5)		EY		
NEPSI IIC Ex d (Note: 6)		EZ		
NEPSI IIC Ex nL (Note: 5)		ES		
Combined NEPSI Ex ia and Ex d (Note: 6)		EP		
Combined NEPSI Ex ia, Ex d and Ex nL (Note: 6)		EQ		
<b>Other Explosion Protection Certifications</b>				
GOST Russia - Ex ia (Note: 7)			W1	
GOST Russia - Ex d (Note: 7)			W2	
GOST Kazakhstan - Ex ia (Note: 7)			W3	
GOST Kazakhstan - Ex d (Note: 7)			W4	
Inmetro Brazil - Ex ia (Note: 7)			W5	
Inmetro Brazil - Ex d (Note: 7)			W6	
Inmetro Brazil - Ex nL (Note: 7)			W7	
Combined Inmetro (Brazil) - Intrinsic Safety, Flameproof and Type N (Note: 7)			W8	
<b>Integral LCD</b>				
With integral LCD display				L1
TTG (Through The Glass) integral digital LCD display				L5

# Model 266GST Gauge

## Model 266AST Absolute

Additional ordering information for model 266GST	XX	XX	XX	XX	XX	XX	XX	XX
<b>Mounting Bracket Shape / Material</b>								
For wall and pipe mounting / Carbon steel (Not suitable for AISI housing)	B1							
For wall and pipe mounting / AISI 316 SST (1.4401)	B2							
<b>Surge / Transient Protector</b>								
With integral surge / transient protector	S2							
<b>Operating Instruction Language</b>								
German			M1					
Italian			M2					
Spanish			M3					
French			M4					
English			M5					
Chinese			M6					
Swedish			M7					
<b>Label and Tag Language</b>								
German						T1		
Italian						T2		
Spanish						T3		
French						T4		
<b>Additional Tag Plate</b>								
Supplemental wired-on stainless steel plate (4 lines, 30 characters each)							I1	
Laser printing of tag on stainless steel plate							I2	
<b>Configuration</b>								
Standard pressure = in. H2O / psi at 68 °F								N2
Standard pressure = in. H2O / psi at 39.2 °F								N3
Standard pressure = in. H2O / psi at 20 °C								N4
Standard pressure = in. H2O / psi at 4 °C								N5
Custom								N6
<b>Preparation Procedure</b>								
Oxygen service cleaning, Pmax = 21 MPa (210 bar, 3045 psi) or sensor overpressure (lower value), Tmax = 60 °C / 140 °F (Only available with inert fill / viton gasket)								P1
Hydrogen service preparation								P2
<b>Certificates</b>								
Inspection certificate 3.1 acc. EN 10204 of calibration								C1
Inspection certificate 3.1 acc. EN 10204 of cleanliness stage								C3
Inspection certificate 3.1 acc. EN 10204 of helium leakage test of the sensor module								C4
Inspection certificate 3.1 acc. EN 10204 of pressure test								C5
Declaration of compliance with the order 2.1 acc. EN 10204 for instrument design								C6
Overfill protection approval								C9
Separate calibration record								CC
Printed record of configured data of transmitter								CG
PMI test on wetted parts								CT

Additional ordering information for model 266GST		XX	XX	XX	XX
<b>Approvals</b>					
GOST Russia - Without Explosion Protection		Y1			
GOST Kazakhstan - Without Explosion Protection		Y2			
GOST Ukraine - Without Explosion Protection		Y3			
GOST Belarus - Without Explosion Protection		Y4			
DNV approval		YA			
Lloyd approval		YB			
Approval for Custody Transfer		YC			
Bureau Veritas approval		YD			
<b>Material Traceability</b>					
Certificate of compliance with the order 2.1 acc. EN 10204 for process wetted parts					H1
Inspection certificate 3.1 acc. EN 10204 of pressure-bearing and process wetted parts with analysis certificates as material verification	(Note: 8)				H3
Material certificate 2.2 acc. EN 10204 for the pressure bearing and process wetted parts					H4
<b>Connector</b>					
Fieldbus 7/8 in. (Recommended for FOUNDATION Fieldbus, supplied loose without female plug)					U1
Fieldbus M12 x 1 (Recommended for PROFIBUS PA, supplied loose without female plug)					U2
Harting Han 8D (8U), straight entry					U3
Harting Han 8D (8U), angle entry					U4
Harting Han 7D					U5
With cable gland M20 x 1.5					U8
<b>Housing Accessories</b>					
Integral mount manifold					A1
Four-wire add-on unit: Power supply 24 V UC / Output signal 0 ... 20 mA	(Note: 9)				A4
Four-wire add-on unit: Power supply 24 V UC / Output signal 4 ... 20 mA	(Note: 9)				A6
Four-wire add-on unit: Power supply 230 V AC / Output signal 0 ... 20 mA	(Note: 9)				A5
Four-wire add-on unit: Power supply 230 V AC / Output signal 4 ... 20 mA	(Note: 9)				A7
Note 1:	Only available with Sensor Span Limits code C, F with diaphragm made of ceramic				
Note 2:	Only available with Sensor Span Limits code C, F with diaphragm made of ceramic / Suitable for oxygen applications				
Note 3:	Select connector with additional ordering code				
Note 4:	Not available with Sensor Span Limits / Overpressure code C, F, V				
Note 5:	Not available with Housing Material / Electrical Connection code E, G, K, W, Z				
Note 6:	Not available with Housing Material / Electrical Connection code E, G, J, K, W, Z				
Note 7:	Not available with Explosion Protection Certification code E1, E2, E3, E4, E6, E8, E9, EA, EB, EC, EN, ER, EW, E7, EH, EI, EY, EZ, ES, EP, EQ				
Note 8:	Minor parts with factory certificate acc. EN 10204				
Note 9:	Only available with Housing Material / Electrical Connection code B (Barrel housing)				

### Standard delivery scope (changes possible with additional ordering code)

- For standard applications (without explosion protection)
- No display, no mounting bracket, no surge protection
- Multilanguage short-form operating instruction and English labeling
- Configuration with kPa and °C units
- No test, inspection, or material certificates

Unless otherwise specified prior to manufacture, the customer shall be responsible for selecting suitable parts that make contact with the medium and appropriate filling liquids in order to ensure compatibility with the relevant measuring medium. Compliance with the NACE regulation is based on recommendations MR0175 / ISO 15156. Additionally, stainless steel AISI 316, AISI 316L and Hastelloy C-276 automatically meet the criteria of MR0103, provided that they also meet the criteria of MR0175.

# Model 266GST Gauge

## Model 266AST Absolute

### Basic ordering information model 266AST Absolute Pressure Transmitter

Select one character or set of characters from each category and specify complete catalog number.

Refer to additional ordering information and specify one or more codes for each transmitter if additional options are required.

Base model – Characters 1 through 6				266AST	X	X	X	X	X	X
Absolute pressure transmitter – base accuracy 0.04 %										
<b>Sensor Span Limits / Overpressure</b> – 7 <sup>th</sup> character										continued see next page
0.3 and 6 kPa	(3 and 60 mbar, 1.2 and 24 in. H <sub>2</sub> O, 2.25 and 45 mm Hg)	1 MPa (10 bar, 145 psi)	C							
2 and 40 kPa	(20 and 400 mbar, 15 and 300 mm Hg)	1 MPa (10 bar, 145 psi)	F							
12.5 and 250 kPa	(125 and 2500 mbar, 98.3 and 1875 mm Hg)	0.5 MPa (5 bar, 72.5 psi)	L							
50 and 1000 kPa	(0.5 and 10 bar, 7.25 and 145 psi)	2 MPa (20 bar, 290 psi)	D							
150 and 3000 kPa	(1.5 and 30 bar, 21.7 and 435 psi)	6 MPa (60 bar, 870 psi)	U							
500 and 10000 kPa	(5 and 100 bar, 72.5 and 1450 psi)	20 MPa (200 bar, 2900 psi)	R							
<b>Diaphragm Material / Fill Fluid</b> – 8 <sup>th</sup> character										
AISI 316L SST (1.4435)	Silicone oil (Only available with front bonded diaphragm)	NACE	S							
Hastelloy C-276	Silicone oil	NACE	K							
AISI 316L SST	Inert fluid - Galden									
	(Only available with front bonded diaphragm / suitable for oxygen applications)	NACE	A							
Hastelloy C-276	Inert fluid - Galden (Suitable for oxygen applications)	NACE	F							
Hastelloy C-276 gold-plated	Silicone oil	NACE	G							
Hastelloy C-276 gold-plated	Inert fluid - Galden (Suitable for oxygen applications)	NACE	E							
AISI 316L SST	White oil (FDA) (Only available with front bonded diaphragm)	NACE	6							
Hastelloy C-276	White oil (FDA)	NACE	Z							
Ceramic	No filling	NACE	(Note: 1) J							
<b>Process Connection Material / Type</b> – 9 <sup>th</sup> character										
AISI 316L SST (1.4404)	1/2-14 NPT female	NACE								B
AISI 316L SST (1.4404)	DIN EN 837-1 G 1/2 B	NACE								P
AISI 316L SST (1.4404)	G 1/2 in. front bonded diaphragm	NACE								S
AISI 316L SST (1.4404)	1/2-14 NPT male	NACE								T
Hastelloy C-276	1/2-14 NPT female	NACE								E
Hastelloy C-276	DIN EN 837-1 G 1/2 B	NACE								D
Hastelloy C-276	1/2-14 NPT male	NACE								K

Basic ordering information model 266AST Absolute Pressure Transmitter			X	X	X
<b>Gasket – 10<sup>th</sup> character</b>					
Viton		(Note: 2)	5		
Perfluorelastomere (max. 0.6 MPa / 6 bar / 87 psi)		(Note: 1)	6		
Perbunan (NBR)		(Note: 1)	8		
None			N		
<b>Housing Material / Electrical Connection – 11<sup>th</sup> character</b>					
Aluminium alloy (Barrel type)	1/2-14 NPT				A
Aluminium alloy (Barrel type)	M20 x 1.5				B
Aluminium alloy (Barrel type)	Harting Han connector (General purpose only)	(Note: 3)			E
Aluminium alloy (Barrel type)	Fieldbus connector (General purpose only)	(Note: 3)			G
AISI 316L SST (Barrel type)	1/2-14 NPT				S
AISI 316L SST (Barrel type)	M20 x 1.5				T
Aluminium alloy (DIN type)	M20 x 1.5				J
Aluminium alloy (DIN type)	Harting Han connector (General purpose only)	(Note: 3)			K
Aluminium alloy (DIN type)	Fieldbus connector (General purpose only)	(Note: 3)			W
AISI 316L SST (Barrel type)	Fieldbus connector (General purpose only)	(Note: 3)			Z
<b>Output – 12<sup>th</sup> character</b>					
HART digital communication and 4 ... 20 mA (No additional options)					H
HART digital communication and 4 ... 20 mA (Options requested by "Additional ordering code")					1
PROFIBUS PA (No additional options)					P
PROFIBUS PA (Options requested by "Additional ordering code")					2
FOUNDATION Fieldbus (No additional options)					F
FOUNDATION Fieldbus (Options requested by "Additional ordering code")					3
HART digital communication and 4 ... 20 mA, SIL2 and SIL3 certified to IEC 61508 (No additional options)					T
HART digital communication and 4 ... 20 mA, SIL2 and SIL3 certified to IEC 61508 (Options requested by "Additional ordering code")					8

# Model 266GST Gauge

## Model 266AST Absolute

### Additional ordering information for model 266AST

Add one or more 2-digit code(s) after the basic ordering information to select all required options.

	XX	XX	XX
<b>Explosion protection</b>			
ATEX Group II Category 1 GD - Intrinsic Safety Ex ia (Note: 4)	E1		
ATEX Group II Category 1/2 GD - Flameproof Ex d (Note: 5)	E2		
ATEX Group II Category 3 GD - Type of protection "N" Ex nL design compliance (Note: 4)	E3		
FM approval (Canada, CSA) Class I, II, Div. 1, 2, Group A to F (XP, IS, NI) (Note: 5)			
(Only available with 1/2-14 NPT or M20 electrical connections)	E4		
FM approval (USA) Class I, II, Div. 1, 2, Group A to F (XP, IS, NI) (Note: 5)			
(Only available with 1/2-14 NPT or M20 electrical connections)	E6		
Combined ATEX Ex ia and Ex d (Note: 5)	E7		
FM approvals (USA and Canada) Intrinsic Safety (Note: 4)			
(Only available with 1/2-14 NPT or M20 electrical connections)	EA		
FM approvals (USA and Canada) Explosion-proof (Note: 5)			
(Only available with 1/2-14 NPT or M20 electrical connections)	EB		
FM approvals (USA and Canada) Non-incendive (Note: 4)			
(Only available with 1/2-14 NPT or M20 electrical connections)	EC		
Combined ATEX, FM and CSA (Only available with 1/2-14 NPT or M20 electrical connections) (Note: 5)	EN		
Combined ATEX - Intrinsic Safety, Flameproof and Type „N“ (Note: 5)	EW		
IEC Approval Group II Category 1 GD - Intrinsic Safety Ex ia (Note: 4)	E8		
IEC Approval Group II Category 1/2 GD - Flameproof Ex d (Note: 5)	E9		
IEC Approval Group II Category 3 GD - Type of protection "N" Ex nL design compliance (Note: 4)	ER		
Combined IEC Approval Ex ia and Ex d (Note: 5)	EH		
Combined IEC Approval Ex ia, Ex d and Ex nL (Note: 5)	EI		
NEPSI IIC Ex ia (Note: 4)	EY		
NEPSI IIC Ex d (Note: 5)	EZ		
NEPSI IIC Ex nL (Note: 4)	ES		
Combined NEPSI Ex ia and Ex d (Note: 5)	EP		
Combined NEPSI Ex ia, Ex d and Ex nL (Note: 5)	EQ		
<b>Other Explosion Protection Certifications</b>			
GOST Russia - Ex ia (Note: 6)		W1	
GOST Russia - Ex d (Note: 6)		W2	
GOST Kazakhstan - Ex ia (Note: 6)		W3	
GOST Kazakhstan - Ex d (Note: 6)		W4	
Inmetro Brazil - Ex ia (Note: 6)		W5	
Inmetro Brazil - Ex d (Note: 6)		W6	
Inmetro Brazil - Ex nL (Note: 6)		W7	
Combined Inmetro (Brazil) - Intrinsic Safety, Flameproof and Type N (Note: 6)		W8	
<b>Integral LCD</b>			
With integral LCD display			L1
TTG (Through The Glass) integral digital LCD display			L5

Additional ordering information for model 266AST	XX	XX	XX	XX	XX	XX	XX	XX
<b>Mounting Bracket Shape / Material</b>								
For wall and pipe mounting / Carbon steel (Not suitable for AISI housing)	B1							
For wall and pipe mounting / AISI 316 SST (1.4401)	B2							
<b>Surge / Transient Protector</b>								
With integral surge / transient protector		S2						
<b>Operating Instruction Language</b>								
German						M1		
Italian						M2		
Spanish						M3		
French						M4		
English						M5		
Chinese						M6		
Swedish						M7		
<b>Label and Tag Language</b>								
German							T1	
Italian							T2	
Spanish							T3	
French							T4	
<b>Additional Tag Plate</b>								
Supplemental wired-on stainless steel plate (4 lines, 30 characters each)							I1	
Laser printing of tag on stainless steel plate							I2	
<b>Configuration</b>								
Standard pressure = in. H2O / psi at 68 °F								N2
Standard pressure = in. H2O / psi at 39.2 °F								N3
Standard pressure = in. H2O / psi at 20 °C								N4
Standard pressure = in. H2O / psi at 4 °C								N5
Custom								N6
<b>Preparation Procedure</b>								
Oxygen service cleaning, Pmax = 21 MPa (210 bar, 3045 psi) or sensor overpressure (lower value), Tmax = 60 °C / 140 °F (Only available with inert fill / viton gasket)								P1
Hydrogen service preparation								P2
<b>Certificates</b>								
Inspection certificate 3.1 acc. EN 10204 of calibration								C1
Inspection certificate 3.1 acc. EN 10204 of cleanliness stage								C3
Inspection certificate 3.1 acc. EN 10204 of helium leakage test of the sensor module								C4
Inspection certificate 3.1 acc. EN 10204 of pressure test								C5
Declaration of compliance with the order 2.1 acc. EN 10204 for instrument design								C6
Separate calibration record								CC
Printed record of configured data of transmitter								CG
PMI test on wetted parts								CT

# Model 266GST Gauge

## Model 266AST Absolute

Additional ordering information for model 266AST	XX	XX	XX	XX
<b>Approvals</b>				
GOST Russia - Without Explosion Protection	Y1			
GOST Kazakhstan - Without Explosion Protection	Y2			
GOST Ukraine - Without Explosion Protection	Y3			
GOST Belarus - Without Explosion Protection	Y4			
DNV approval	YA			
Lloyd approval	YB			
Approval for Custody Transfer	YC			
Bureau Veritas approval	YD			
<b>Material Traceability</b>				
Certificate of compliance with the order 2.1 acc. EN 10204 for process wetted parts		H1		
Inspection certificate 3.1 acc. EN 10204 of pressure-bearing and process wetted parts with analysis certificates as material verification	(Note: 7)	H3		
Material certificate 2.2 acc. EN 10204 for the pressure bearing and process wetted parts		H4		
<b>Connector</b>				
Fieldbus 7/8 in. (Recommended for FOUNDATION Fieldbus, supplied loose without female plug)				U1
Fieldbus M12 x 1 (Recommended for PROFIBUS PA, supplied loose without female plug)				U2
Harting Han 8D (8U), straight entry				U3
Harting Han 8D (8U), angle entry				U4
Harting Han 7D				U5
With cable gland M20 x 1.5				U8
<b>Housing Accessories</b>				
Integral mount manifold				A1
Four-wire add-on unit: Power supply 24 V UC / Output signal 0 ... 20 mA	(Note: 8)			A4
Four-wire add-on unit: Power supply 24 V UC / Output signal 4 ... 20 mA	(Note: 8)			A6
Four-wire add-on unit: Power supply 230 V AC / Output signal 0 ... 20 mA	(Note: 8)			A5
Four-wire add-on unit: Power supply 230 V AC / Output signal 4 ... 20 mA	(Note: 8)			A7
Note 1:	Only available with Sensor Span Limits code C, F with diaphragm made of ceramic			
Note 2:	Only available with Sensor Span Limits code C, F with diaphragm made of ceramic / Suitable for oxygen applications			
Note 3:	Select connector with additional ordering code			
Note 4:	Not available with Housing Material / Electrical Connection code E, G, K, W, Z			
Note 5:	Not available with Housing Material / Electrical Connection code E, G, J, K, W, Z			
Note 6:	Not available with Explosion Protection Certification code E1, E2, E3, E4, E6, E8, E9, EA, EB, EC, EN, ER, EW, E7, EH, EI, EY, EZ, ES, EP, EQ			
Note 7:	Minor parts with factory certificate acc. EN 10204			
Note 8:	Only available with Housing Material / Electrical Connection code B (Barrel housing)			

### Standard delivery scope (changes possible with additional ordering code)

- For standard applications (without explosion protection)
- No display, no mounting bracket, no surge protection
- Multilanguage short-form operating instruction and English labeling
- Configuration with kPa and °C units
- No test, inspection, or material certificates

Unless otherwise specified prior to manufacture, the customer shall be responsible for selecting suitable parts that make contact with the medium and appropriate filling liquids in order to ensure compatibility with the relevant measuring medium. Compliance with the NACE regulation is based on recommendations MR0175 / ISO 15156. Additionally, stainless steel AISI 316, AISI 316L and Hastelloy C-276 automatically meet the criteria of MR0103, provided that they also meet the criteria of MR0175.







# Contact us

## **ABB Ltd.**

### **Process Automation**

Howard Road, St. Neots  
Cambridgeshire, PE19 8EU  
UK

Tel: +44 (0)1480 475321

Fax: +44 (0)1480 217948

## **ABB Inc.**

### **Process Automation**

125 E. County Line Road  
Warminster PA 18974  
USA

Tel: +1 215 674 6000

Fax: +1 215 674 7183

## **ABB Automation Products GmbH**

### **Process Automation**

Schillerstr. 72  
32425 Minden  
Germany

Tel: +49 551 905-534

Fax: +49 551 905-555

[www.abb.com](http://www.abb.com)

## Note

We reserve the right to make technical changes or modify the contents of this document without prior notice. With regard to purchase orders, the agreed particulars shall prevail. ABB does not accept any responsibility whatsoever for potential errors or possible lack of information in this document.

We reserve all rights in this document and in the subject matter and illustrations contained therein. Any reproduction, disclosure to third parties or utilization of its contents - in whole or in parts - is forbidden without prior written consent of ABB.

Copyright© 2011 ABB

All rights reserved

3KXP200011R1001

™ Hastelloy C276 is a Cabot Corporation trademark

™ Viton is a Dupont de Nemour trademark

™ Galden is a Montefluos trademark