

TTF300

Field mounted Temperature Transmitter

Sensor error adjustment
Sensor redundancy
Sensor drift monitoring



HART, PROFIBUS, FOUNDATION Fieldbus, Pt100 (RTD), thermocouples, electrical isolation

Input

- Resistance thermometer
- Thermocouples
- Resistance-type transmitters
- Voltages, mV voltages

Input functionality

- 1 or 2 sensors
- 2 x Pt100 three-wire circuit

Output

- 4 ... 20 mA, HART
- PROFIBUS PA, profile 3.01
- FOUNDATION Fieldbus H1, ITK version 5.2

Specific linearization

- Callendar-Van Dusen coefficients
- Table of variate pairs / 32 points

Continuous sensor monitoring and self-monitoring

- Supply voltage monitoring
- Wire break and corrosion monitoring in accordance with NE 89
- Extended diagnostics in accordance with NE 107

Device safety in accordance with NE 53 and NE 79

SW write protection, HW write protection

SIL2/3 in accordance with IEC 61508 (for HART)

Approvals for explosion protection

- ATEX, IECEx
- FM / CSA
- GOST (for HART)

Configuration

- LCD indicators
- DTM
- EDD

Service interface

Contents

1	Specifications	4
1.1	Input	4
1.2	Output	5
1.3	Power supply (polarity safe)	5
2	General information	6
2.1	Ambient conditions	6
2.2	SIL functional safety	6
2.3	ElectroMagnetic Compatibility	6
2.4	Interference immunity	6
2.5	Mechanical design	6
2.6	Measuring accuracy	7
2.7	Operating influences	8
3	Communication	9
3.1	Configuration parameters	9
3.2	HART	9
3.3	PROFIBUS PA	10
3.4	FOUNDATION Fieldbus	10
4	Electrical connections	11
5	Dimensions	12
6	Ordering information	13
6.1	Documentation available for ordering	15
7	Ex relevant specifications	15
7.1	TTF300-E1X, intrinsic safety ATEX	15
7.2	TTF300-H1X, intrinsic safety IECEx	15
7.3	Safety specifications for Intrinsic Safety ATEX / IECEx	15
7.4	TTF300-E5X, non-sparking + dust explosion protection ATEX	16
7.5	TTF300-D1X, dust explosion protection ATEX	16
7.6	TTF300-D2X, dust explosion protection + intrinsic safety ATEX	16
7.7	TTF300-E3X, flameproof enclosure ATEX	16
7.8	TTF300-E4X, flameproof enclosure + intrinsic safety ATEX	16
7.9	TTF300-L1X, intrinsically safe FM	16
7.10	TTF300-L2X, non-incendive FM	16
7.11	TTF300-L3X, explosion proof FM	16
7.12	TTF300-L7X, explosion proof + intrinsically safe FM	16
7.13	TTF300-R1X, intrinsically safe CSA	16
7.14	TTF300-R2X, non-incendive CSA	16
7.15	TTF300-R3X, explosion proof CSA	16
7.16	TTF300-R7X, explosion proof + intrinsically safe CSA	16
8	Type B LCD	17

8.1	Features	17
8.2	Specifications	17
8.3	Configuration function	17
8.4	Ex relevant specifications	17
9	Order form configuration.....	19
9.1	HART device design: Data relating to customer-specific configuration	19
9.2	PROFIBUS PA / FOUNDATION Fieldbus device design	20

1 Specifications

1.1 Input

1.1.1 Resistance thermometers / Resistors

Resistance thermometers

Pt100 in accordance with IEC 60751, JIS C1604-89,
MIL-T-24388,
Ni in accordance with DIN 43760, Cu

Resistance measurement

0 ... 500 Ω
0 ... 5000 Ω

Sensor connection type

Two-, three-, four-wire circuit

Connecting cable

Maximum sensor line resistance (R_W) for each line 50 Ω
according to NE 89 (January 2009)
Three-wire circuit:
symmetrical sensor line resistances
Two-wire circuit:
compensation up to 100 Ω total line resistance

Measurement current

< 300 μ A

Sensor short circuit

< 5 Ω (for resistance thermometer)

Sensor wire break

Measuring range: 0 ... 500 Ω > 0.6 ... 10 k Ω
Measuring range: 0 ... 5 k Ω > 5.3 ... 10 k Ω

Corrosion detection in accordance with NE 89

Three-wire resistance measurement > 50 Ω
Four-wire resistance measurement > 50 Ω

Sensor error signaling

Resistance thermometers: Short circuit and wire break
Linear resistance measurement: Wire break

1.1.2 Thermocouples / Voltages

Types

B, E, J, K, N, R, S, T in accordance with IEC 60584
U, L in accordance with DIN 43710
C, D in accordance with ASTM E-988

Voltages

-125 ... 125 mV
-125 ... 1100 mV

Connecting cable

Maximum sensor line resistance (R_W) for each line: 1.5 k Ω ,
total: 3 k Ω

Sensor wire-break monitoring in accordance with NE 89

Pulsed with 1 μ A outside measurement interval
Thermocouple measurement 5.3 ... 10 k Ω
Voltage measurement 5.3 ... 10 k Ω

Input resistance

> 10 M Ω

Internal reference point

Pt1000, IEC 60751 Cl. B
(no additional jumpers necessary)

Sensor error signaling

Thermocouple: Wire break
Linear voltage measurement: Wire break

1.1.3 Functionality

Freestyle characteristics and 32-point sampling table

Resistance measurement up to maximum 5 k Ω
Voltages up to maximum 1.1 V

Sensor error adjustment

Via Callendar van Dusen coefficients
Via table of 32 sampling points
Via single-point adjustment (offset adjustment)
Via two-point adjustment

Input functionality

1 sensor
2 sensors:
mean measurement,
differential measurement,
sensor redundancy,
sensor drift monitoring

1.2 Output

1.2.1 HART output

Transmission characteristics

Temperature linear
Resistance linear
Voltage linear

Output signal

Configurable 4 ... 20 mA (standard)
Configurable 20 ... 4 mA
(dynamic range: 3.8 ... 20.5 mA in accordance with NE 43)

Simulation mode

3.5 ... 23.6 mA

Induced current consumption

< 3.5 mA

Maximum output current

23.6 mA

Configurable error current signal

Override 22 mA (20.0 ... 23.6 mA)
Underdrive 3.6 mA (3.5 ... 4.0 mA)

1.2.2 PROFIBUS PA output

Output signal

PROFIBUS – MBP (IEC 61158-2)
baud rate 31.25 kbit/s
PA profile 3.01
FISCO-compliant (IEC 60079-27)
IDENT_ NUMBER: 0x3470 [0x9700]

Error current signal

FDE (Fault Disconnection Electronic)

Block structure

Physical block
transducer block 1 – temperature
transducer block 2 – HMI (LCD)
transducer block 3 – extended diagnostics
analog input 1 – primary value (calculated value*)
analog input 2 – SECONDARY VALUE_1 (sensor 1)
analog input 3 – SECONDARY VALUE_2 (sensor 2)
analog input 4 – SECONDARY VALUE_3 (reference point temp.)
analog output – optional HMI display (transducer block 2)
discrete input 1 – extended diagnostics 1 (transducer block 3)
discrete input 2 – extended diagnostics 2 (transducer block 3)
* Sensor 1, sensor 2, or difference, or mean

1.2.3 FOUNDATION Fieldbus output

Output signal

FOUNDATION Fieldbus H1 (IEC 61158-2)
Baud rate 31.25 kbit/s, ITK 5.2
FISCO-compliant (IEC 60079-27)
Device ID: 0003200125

Error current signal

FDE (Fault Disconnection Electronic)

Block structure ¹⁾

Resource block
Transducer block 1 – temperature
Transducer block 2 – HMI (LCD)
Transducer block 3 – extended diagnostics
Analog input 1 – PRIMARY_VALUE_1 (sensor 1)
Analog input 2 – PRIMARY_VALUE_2 (sensor 2)
Analog input 3 – PRIMARY_VALUE_3 (calculated value*)
Analog input 4 – SECONDARY_VALUE (reference point temp.)
Analog output – optional HMI display (transducer block 2)
Discrete input 1 – extended diagnostics 1 (transducer block 3)
Discrete input 2 – extended diagnostics 2 (transducer block 3)
PID – PID controller
* Sensor 1, sensor 2, or difference, or mean

LAS (Link Active Scheduler) link master functionality

¹⁾ For the block description, block index, execution times, and block class, refer to the interface description.

1.3 Power supply (polarity safe)

Two-wire technology; supply power lines = signal lines

1.3.1 HART supply power

Supply voltage

Non-ignition-proof application: $U_S = 11 \dots 42 \text{ V DC}$
Ignition-proof applications: $U_S = 11 \dots 30 \text{ V DC}$

Max. permissible residual ripple for supply voltage

During communication in accordance with HART FSK
"Physical Layer" specification, version 8.1 (August 1999) Section 8.1

Undervoltage detection

$U_{\text{Terminal-Mu}} < 10 \text{ V}$ results in $I_a = 3.6 \text{ mA}$

Maximum load

$R_{\text{Load}} = (\text{supply voltage} - 11 \text{ V}) / 0.022 \text{ A}$

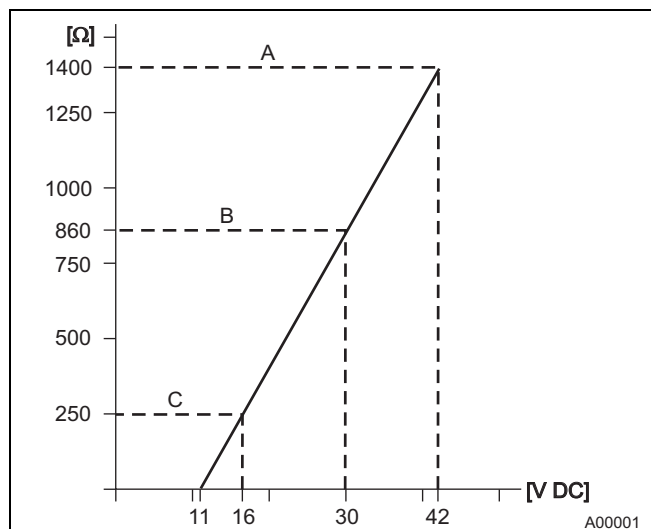

Fig. 1: Maximum load depending on supply voltage

- A TTF300
- B TTF300 In ia hazardous area design
- C HART communication resistor

Maximum power consumption

$P = U_S \times 0.022 \text{ A}$

e.g., $U_S = 24 \text{ V} \rightarrow P_{\text{max}} = 0.528 \text{ W}$

1.3.2 PROFIBUS / FOUNDATION Fieldbus supply power

Supply voltage

Non-ignition-proof application: $U_S = 9 \dots 32 \text{ V DC}$

Ignition-proof applications:

$U_S = 9 \dots 17.5 \text{ V DC}$ (FISCO)

$U_S = 9 \dots 24 \text{ V DC}$ (Fieldbus Entity model I.S.)

Current consumption $\leq 12 \text{ mA}$

2 General information

CE marking

The TTF300 meets all requirements as regards the CE marking in accordance with the applicable guidelines.

Electrical isolation

3.5 kV DC (approx. 2.5 kV AC), 60 s, input to output

MTBF time

28 years at 60 °C ambient temperature

Input filter

50 / 60 Hz

Switch-on delay

HART: < 10 s ($I_a \leq 3.6$ mA during starting cycle)

PROFIBUS: 10 s, max. 30 s

FOUNDATION Fieldbus: < 10 s

Warm-up time

5 minutes

Ramp-up time t_{90}

400 ... 1000 ms

Rate updated

10/s with 1 sensor, 5/s with 2 sensors, depending on sensor type and sensor circuit

Output filter

Digital filter 1st order: 0 ... 100 s

2.1 Ambient conditions

Ambient temperature

Standard: -40 ... 85 °C (-40 ... 185 °F)

Optional: -50 ... 85 °C (-58 ... 185 °F)

Restricted range with hazardous area design

Transport / storage temperature

-50 ... 85 °C (-58 ... 185 °F)

Climate class

Cx -40 ... 85 °C (-40 ... 185 °F) at

5 ... 95 % relative humidity, DIN EN 60654-1

Max. permissible humidity

100 % relative humidity, IEC 60068-2-30

Vibration resistance

10 ... 2000 Hz at 5 g in acc. with IEC 60068-2-6, during operation and transport

Shock

gn = 30 in acc. with IEC 68-2-27, during operation and transport

Degrees of protection

IP 66 and IP 67; NEMA 4X, ENCL 4X

2.2 SIL functional safety

Conforms with IEC 61508 as regards use in safety-related applications, up to and including SIL 2/3.

Only applies to the HART version.

2.3 ElectroMagnetic Compatibility

Emitted interference in accordance with IEC 61326 (2005) and Namur NE 21 (08/2007)

2.4 Interference immunity

Interference-immune in accordance with IEC 61326 (2005) and Namur NE 21 (08/2007)

Pt100: measuring range 0 ... 100 °C (32 ... 212 °F), span 100 K

Type of test	Testing accuracy	Influence
Burst to signal/data lines	2 kV	< 0.5 %
Static discharge:		
• Contact plate (indirect)	8 kV	No
• Supply terminals ¹⁾	6 kV	No
• Sensor terminals ¹⁾	4 kV	No
Radiated field 80 MHz ... 2 GHz	10 V/m	< 0.5 %
Coupling 150 kHz ... 80 MHz	10 V	< 0.5 %
Surge:		
between the supply lines	0.5 kV	No malfunction
Line to ground	1 kV	No malfunction

1) Air discharge (at 1 mm (0.04 inch) distance)

2.5 Mechanical design

Dimensions

See Section 5, "Dimensions"

Weight

1.25 kg (2.76 lb)

Material

Housing: die-cast aluminum, epoxy-coated

Color: gray RAL 9002

Stainless steel

Installation conditions

Installation position: no limitations

Electrical connection

Thread (selectable) 2 x M20 x 1.5 / 2 x 1/2" NPT / 2 x 3/4" NPT (via reducing piece), ground screw external 6 mm², M5 internal 2 x 2.5 mm², M4 connection terminals for lines up to maximum of 2.5 mm² and handheld terminal interface

Cable gland 2 x M20 1.5:

maximum cable outer diameter 5 ... 9 mm (0.2 ... 0.35 inch), temperature range in acc. with data sheet of the cable gland used

- For non-ignition-proof and non-incendive polyamide, gray

- For intrinsically safe design and intrinsic safety polyamide, blue

Metal cable gland:

dust-ignition proof, flameproof enclosure, explosion proof, maximum cable outer diameter 6 ... 7.5 mm (0.24 ... 0.3 inch), temperature range: -20 ... 85 °C (-4 ... 185 °F)

Lightning protection

For cable gland M20 x 1.5

(see data sheet 10/63-6.15)

Non-ignition-proof: model NGV220-NO

Intrinsically safe: model NGV220-EX

2.6 Measuring accuracy

Includes linearity deviation. reproducibility / hysteresis at 23 °C (73.4 °F) ± 5 K and 20 V supply voltage

Information on measuring accuracy corresponds to 3 σ (Gaussian distribution)

Input element			Measuring range limits	Minimum span	Digital measuring accuracy (24-bit A/D converter)	D/A measuring accuracy ¹⁾ (16-bit DA)
Standard	Sensor					
Resistance thermometer / Resistor						
DIN IEC 60 751	Pt10	(a=0.003850)	-200 ... 850 °C (-328 ... 1562 °F)	10 °C (18 °F)	± 0.80 °C (± 1.44 °F)	± 0.05 %
	Pt50	(a=0.003850)	-200 ... 850 °C (-328 ... 1562 °F)	10 °C (18 °F)	± 0.16 °C (± 0.29 °F)	± 0.05 %
	Pt100	(a=0.003850) ²⁾	-200 ... 850 °C (-328 ... 1562 °F)	10 °C (18 °F)	± 0.08 °C (± 0.14 °F)	± 0.05 %
	Pt200	(a=0.003850)	-200 ... 850 °C (-328 ... 1562 °F)	10 °C (18 °F)	± 0.24 °C (± 0.43 °F)	± 0.05 %
	Pt500	(a=0.003850)	-200 ... 850 °C (-328 ... 1562 °F)	10 °C (18 °F)	± 0.16 °C (± 0.29 °F)	± 0.05 %
	Pt1000	(a=0.003850)	-200 ... 850 °C (-328 ... 1562 °F)	10 °C (18 °F)	± 0.08 °C (± 0.14 °F)	± 0.05 %
JIS C1604-89	Pt10	(a=0.003916)	-200 ... 645 °C (-328 ... 1193 °F)	10 °C (18 °F)	± 0.80 °C (± 1.44 °F)	± 0.05 %
	Pt50	(a=0.003916)	-200 ... 645 °C (-328 ... 1193 °F)	10 °C (18 °F)	± 0.16 °C (± 0.29 °F)	± 0.05 %
	Pt100	(a=0.003916)	-200 ... 645 °C (-328 ... 1193 °F)	10 °C (18 °F)	± 0.08 °C (± 0.14 °F)	± 0.05 %
MIL-T-24388	Pt10	(a=0.003920)	-200 ... 850 °C (-328 ... 1562 °F)	10 °C (18 °F)	± 0.80 °C (± 1.44 °F)	± 0.05 %
	Pt50	(a=0.003920)	-200 ... 850 °C (-328 ... 1562 °F)	10 °C (18 °F)	± 0.16 °C (± 0.29 °F)	± 0.05 %
	Pt100	(a=0.003920)	-200 ... 850 °C (-328 ... 1562 °F)	10 °C (18 °F)	± 0.08 °C (± 0.14 °F)	± 0.05 %
	Pt200	(a=0.003920)	-200 ... 850 °C (-328 ... 1562 °F)	10 °C (18 °F)	± 0.24 °C (± 0.43 °F)	± 0.05 %
	Pt500	(a=0.003920)	-200 ... 850 °C (-328 ... 1562 °F)	10 °C (18 °F)	± 0.16 °C (± 0.29 °F)	± 0.05 %
	Pt1000	(a=0.003920)	-200 ... 850 °C (-328 ... 1562 °F)	10 °C (18 °F)	± 0.08 °C (± 0.14 °F)	± 0.05 %
DIN 43760	Ni50	(a=0.006180)	-60 ... 250 °C (-76 ... 482 °F)	10 °C (18 °F)	± 0.16 °C (± 0.29 °F)	± 0.05 %
	Ni100	(a=0.006180)	-60 ... 250 °C (-76 ... 482 °F)	10 °C (18 °F)	± 0.08 °C (± 0.14 °F)	± 0.05 %
	Ni120	(a=0.006180)	-60 ... 250 °C (-76 ... 482 °F)	10 °C (18 °F)	± 0.08 °C (± 0.14 °F)	± 0.05 %
	Ni1000	(a=0.006180)	-60 ... 250 °C (-76 ... 482 °F)	10 °C (18 °F)	± 0.08 °C (± 0.14 °F)	± 0.05 %
	Cu10	(a=0.004270)	-50 ... 200 °C (-58 ... 392 °F)	10 °C (18 °F)	± 0.80 °C (± 1.44 °F)	± 0.05 %
	Cu100	(a=0.004270)	-50 ... 200 °C (-58 ... 392 °F)	10 °C (18 °F)	± 0.08 °C (± 0.14 °F)	± 0.05 %
	Resistance measurement		0 ... 500 Ω	4 Ω	± 32 m Ω	± 0.05 %
	Resistance measurement		0 ... 5000 Ω	40 Ω	± 320 m Ω	± 0.05 %
Thermocouples³⁾ / voltages						
IEC 60584	Type K	(Ni10Cr-Ni5)	-270 ... 1372 °C (-454 ... 2502 °F)	50 °C (90 °F)	± 0.35 °C (± 0.63 °F)	± 0.05 %
	Type J	(Fe-Cu45Ni)	-210 ... 1200 °C (-346 ... 2192 °F)	50 °C (90 °F)	± 0.35 °C (± 0.63 °F)	± 0.05 %
	Type N	(Ni14CrSi-NiSi)	-270 ... 1300 °C (-454 ... 2372 °F)	50 °C (90 °F)	± 0.35 °C (± 0.63 °F)	± 0.05 %
	Type T	(Cu-Cu45Ni)	-270 ... 400 °C (-454 ... 752 °F)	50 °C (90 °F)	± 0.35 °C (± 0.63 °F)	± 0.05 %
	Type E	(Ni10Cr-Cu45Ni)	-270 ... 1000 °C (-454 ... 1832 °F)	50 °C (90 °F)	± 0.35 °C (± 0.63 °F)	± 0.05 %
	Type R	(Pt13Rh-Pt)	-50 ... 1768 °C (-58 ... 3215 °F)	100 °C (180 °F)	± 0.95 °C (± 1.71 °F)	± 0.05 %
	Type S	(Pt10Rh-Pt)	-50 ... 1768 °C (-58 ... 3215 °F)	100 °C (180 °F)	± 0.95 °C (± 1.71 °F)	± 0.05 %
	Type B	(Pt30Rh-Pt6Rh)	-0 ... 1820 °C (32 ... 3308 °F)	100 °C (180 °F)	± 0.95 °C (± 1.71 °F)	± 0.05 %
DIN 43710	Type L	(Fe-CuNi)	-200 ... 900 °C (-328 ... 1652 °F)	50 °C (90 °F)	± 0.35 °C (± 0.63 °F)	± 0.05 %
	Type U	(Cu-CuNi)	-200 ... 600 °C (-328 ... 1112 °F)	50 °C (90 °F)	± 0.35 °C (± 0.63 °F)	± 0.05 %
ASTM E 988	Type C		-0 ... 2315 °C (32 ... 4200 °F)	100 °C (180 °F)	± 1.35 °C (± 2.43 °F)	± 0.05 %
	Type D		-0 ... 2315 °C (32 ... 4200 °F)	100 °C (180 °F)	± 1.35 °C (± 2.43 °F)	± 0.05 %
	Voltage measurement		-125 ... 125 mV	2 mV	± 12 μ V	± 0.05 %
	Voltage measurement		-125 ... 1100 mV	20 mV	± 120 μ V	± 0.05 %

Long-term drift

± 0.05 °C (± 0.09 °F) or ± 0.05 %¹⁾ per year. the larger value applies.

1) Percentages refer to the configured measuring span

2) Standard model

3) Include the internal reference point error for digital measuring accuracy: Pt1000. DIN IEC 60751 Cl. B

4) Without reference junction error

2.7 Operating influences

The percentages refer to the configured measuring span.

Influence of supply voltage / load: within the specified limits for the voltage / load, the total influence is less than 0.001 % per volt

Normal-mode rejection: > 65 dB at 50 / 60 Hz,

Common-mode rejection: > 120 dB at 50 / 60 Hz

Influence of ambient temperature: based on 23 °C (73.4 °F) for an ambient temperature range of -40 ... 85 °C (-40 ... 185 °F) ⁴⁾

Sensor	Influence of ambient temperature per 1 °C (1.8 °F) deviation from 23 °C (73.4 °F) for digital measurement	Influence of ambient temperature ¹⁾²⁾ per 1 °C (1.8 °F) deviation from 23 °C (73.4 °F) for D/A converter
Resistance thermometer for two-, three-, four-wire circuits		
Pt10 IEC, JIS, MIL	± 0,04 °C (± 0,072 °F)	± 0,003 %
Pt50 IEC, JIS, MIL	± 0,008 °C (± 0,014 °F)	± 0,003 %
Pt100 IEC, JIS, MIL	± 0,004 °C (± 0,007 °F)	± 0,003 %
Pt200 IEC, MIL	± 0,02 °C (± 0,036 °F)	± 0,003 %
Pt500 IEC, MIL	± 0,008 °C (± 0,014 °F)	± 0,003 %
Pt1000 IEC, MIL	± 0,004 °C (± 0,007 °F)	± 0,003 %
Ni50 DIN 43760	± 0,008 °C (± 0,014 °F)	± 0,003 %
Ni100 DIN 43760	± 0,004 °C (± 0,007 °F)	± 0,003 %
Ni120 DIN 43760	± 0,003 °C (± 0,005 °F)	± 0,003 %
Ni1000 DIN 43760	± 0,004 °C (± 0,007 °F)	± 0,003 %
Cu10	± 0,04 °C (± 0,072 °F)	± 0,003 %
Cu100	± 0,004 °C (± 0,007 °F)	± 0,003 %
Resistance measurement		
0 ... 500 Ω	± 0,002 Ω	± 0,003 %
0 ... 5000 Ω	± 0,02 Ω	± 0,003 %
Thermocouple, for all defined types	± [(0,001 % x (ME[mV] / MS[mv]) + (100 % x (0,009 °C / MS [°C]))] ³⁾	± 0,003 %
Voltage measurement		
-125 ... 125 mV	± 1,5 μV	± 0,003 %
-125 ... 1100 mV	± 15 μV	± 0,003 %

1) Percentages refer to the configured measuring span of the analog output signal

2) Influence of the D/A converter omitted for PROFIBUS PA and FOUNDATION Fieldbus H1

3) ME = voltage value of the thermocouple at the end of the measuring range in accordance with the standard
MA = voltage value of the thermocouple at the start of the measuring range in accordance with the standard
MS = voltage value of the thermocouple over the measuring span in accordance with the standard. MS = (ME - MA)

4) In the case of the option to expand the ambient temperature range down to -50 °C (-58 °F), the causal variables are doubled in the range between -50 ... -40 °C (-58 ... -40 °F).

3 Communication

3.1 Configuration parameters

Measurement type

- Sensor type, connection type
- Error signaling
- Measuring range
- General information, e.g., TAG number
- Damping
- Warning and alarm limits
- Signal simulation of output
- For additional information, see Section 9, "Order form configuration"

Write protection

- Software and hardware write protection

Diagnostic information in accordance with NE 107

Standard:

- Sensor error (wire break or short circuit)
- Device error
- Over / under alarm limits
- Over / under measuring range
- Simulation active

Advanced:

- Sensor redundancy / sensor backup active (in case sensor fails) with configurable analog alarm pulse signaling
- Drift monitoring with configurable alarm pulse signaling
- Sensor / sensor supply line corrosion
- Supply voltage undershoot
- Drag indicator for sensor 1, sensor 2, and ambient temperature
- Ambient temperature overshoot
- Ambient temperature undershoot
- Operating hours counter

3.2 HART

The device is listed with the HART Communication Foundation.

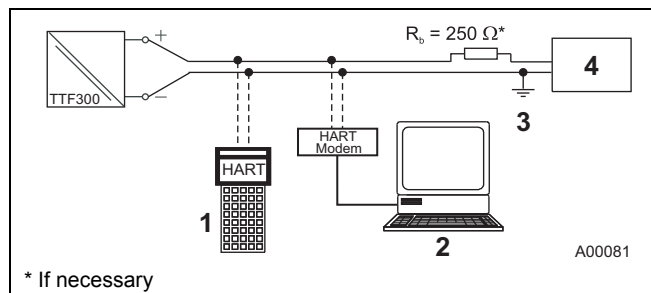

Fig. 2: Example for HART interface connection

- 1 Handheld terminal
- 2 FDT / DTM technology
- 3 Ground connection (optional)
- 4 Power unit (process interface)

Manufacturer ID:	0x1A
Device ID:	0x0A
Profile:	HART 5.1
Configuration:	Directly on the device DTM EDD
Transmission signal:	BELL Standard 202

Operating modes

- Point-to-point communication mode: standard (general address 0)
- Multidrop mode (addressing 1 ... 15)
- Burst mode

Configuration options and tools

Driver-independent:

- LCD indicators with configuration function

Driver-dependent:

- Device management / asset management tools
- DTM technology – via TTX300 DTM driver
- EDD - via TTX300 EDD driver

Diagnostic signaling

- Overdrive / underdrive in accordance with NE 43
- HART diagnostics

3.3 PROFIBUS PA

The interface conforms to profile 3.01 (PROFIBUS standard, EN 50170, DIN 1924 [PRO91]).

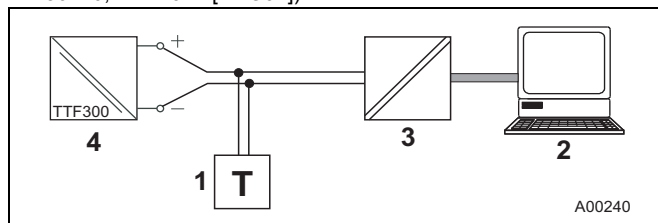

Fig. 3: Example for PROFIBUS PA interface connection

- 1 Bus termination
- 2 PC / DCS
- 3 Segment coupler
- 4 Transmitter

Manufacturer ID:	0x1A
IDENT_NUMBER:	0x3470 [0x9700]
Profile:	PA 3.01
Configuration:	Directly on the device DTM EDD GSD
Transmission signal:	IEC 61158-2

Voltage / current consumption

Average current consumption: 12 mA
 In the event of an error, the integrated FDE (= Fault Disconnection Electronic) function integrated in the device ensures that the current consumption can rise to a maximum of 20 mA.

3.4 FOUNDATION Fieldbus

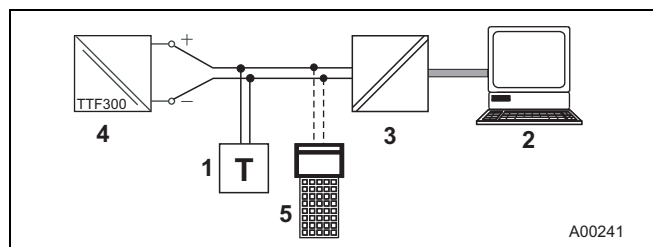

Fig. 4: Example for FOUNDATION Fieldbus interface connection

- 1 Bus termination
- 2 PC / DCS
- 3 Linking device
- 4 Transmitter
- 5 Handheld terminal

DEVICE ID:	000320001F...
ITK:	5.2
Configuration:	Directly on the device EDD
Transmission signal:	IEC 61158-2

Voltage / current consumption

Average current consumption: 12 mA
 In the event of an error, the integrated FDE (= Fault Disconnection Electronic) function integrated in the device ensures that the current consumption can rise to a maximum of 20 mA.

4 Electrical connections

Resistance thermometers (RTD) / resistors (potentiometers)

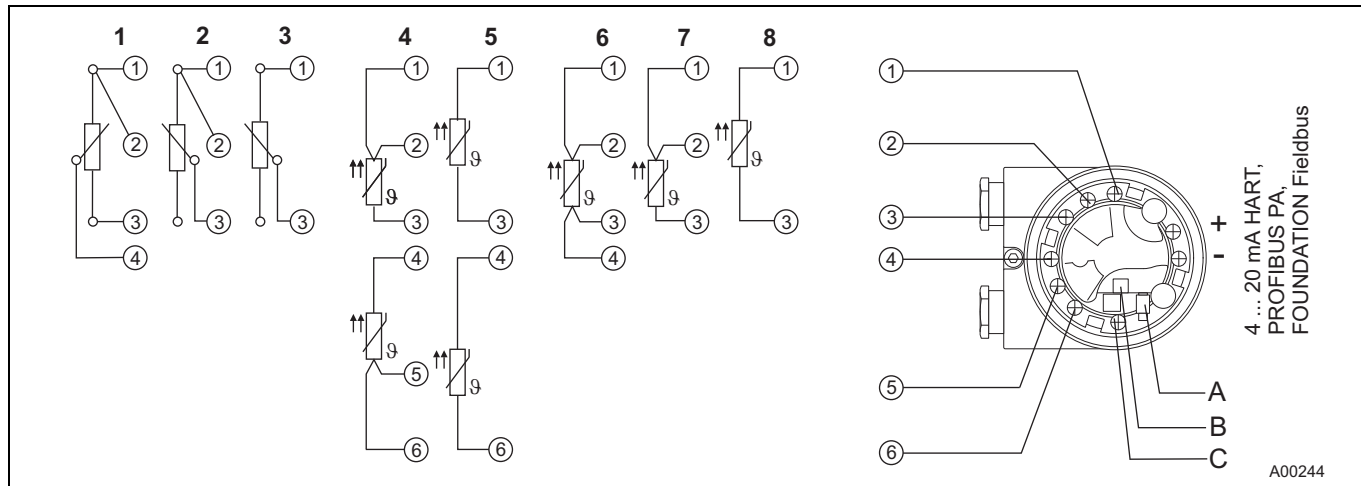

Fig. 5

- | | | | | | |
|---|---|---|---|---|---|
| A | Interface for LCD indicators and service | 1 | Potentiometer, four-wire circuit | 5 | 2 x RTD, two-wire circuit ¹⁾ |
| B | DIP switch 1: on, hardware write protection is enabled
DIP switch 2: no function | 2 | Potentiometer, three-wire circuit | 6 | RTD, four-wire circuit |
| C | Ground terminals for sensor and supply- / signal-cable shield connection | 3 | Potentiometer, two-wire circuit | 7 | RTD, three-wire circuit |
| | | 4 | 2 x RTD, three-wire circuit ¹⁾ | 8 | RTD, two-wire circuit |

¹⁾ Sensor backup / redundancy, sensor drift monitoring, mean measurement or differential measurement

Thermocouples / voltages and resistance thermometer (RTD) / thermocouple combinations

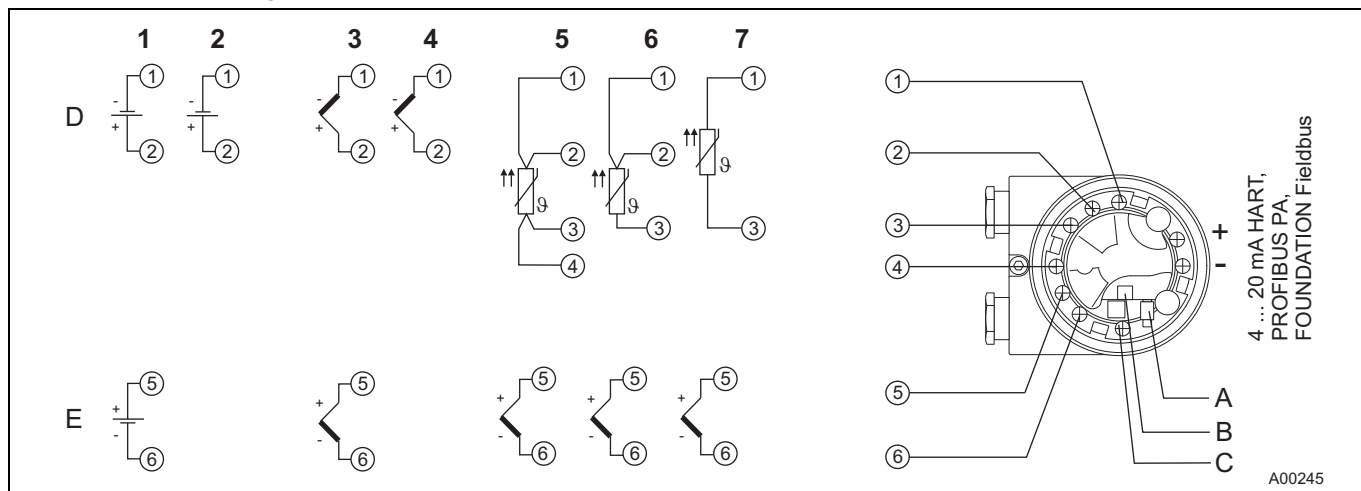

Fig. 6

- | | | | | | |
|---|---|---|---------------------------------------|---|---|
| A | Interface for LCD indicators and service | 1 | 2 x voltage measurement ¹⁾ | 5 | 1 x RTD, four-wire circuit, and thermocouple ¹⁾ |
| B | DIP switch 1: on, hardware write protection is enabled
DIP switch 2: no function | 2 | 1 x voltage measurement | 6 | 1 x RTD, three-wire circuit, and thermocouple ¹⁾ |
| C | Ground terminals for sensor and supply- / signal-cable shield connection | 3 | 2 x thermocouple ¹⁾ | 7 | 1 x RTD, two-wire circuit, and thermocouple ¹⁾ |
| D | Sensor 1 | 4 | 1 x thermocouple | | |
| E | Sensor 2 | | | | |

¹⁾ Sensor backup / redundancy, sensor drift monitoring, mean measurement or differential temperature measurement

5 Dimensions

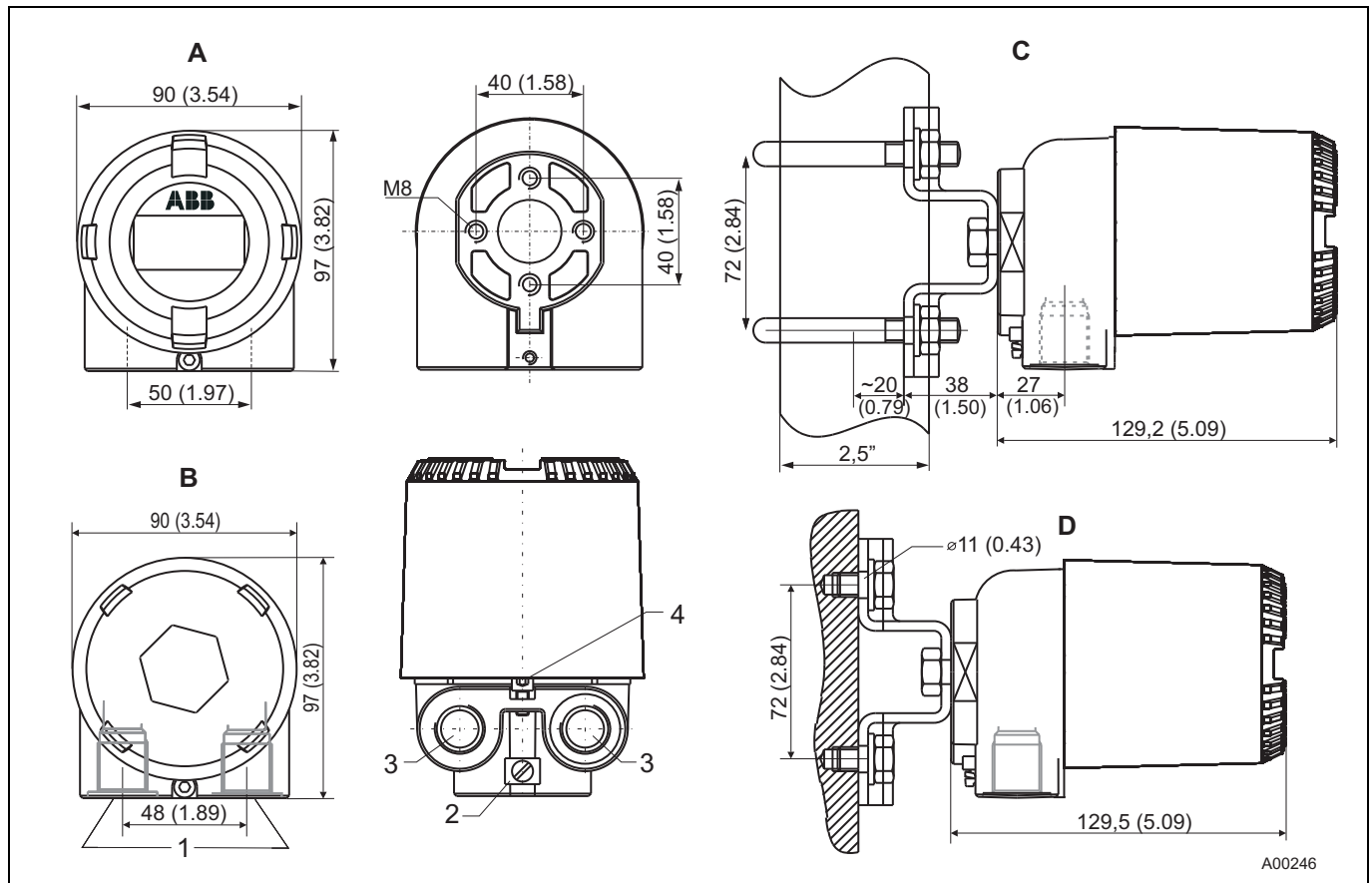

Fig. 7: Dimensions in mm (inch)

- | | |
|---|--|
| <ul style="list-style-type: none"> A Housing with display window in cover B Closed housing C Pipe installation D Wall mount, 4-hole wall attachment, $\varnothing 11$ mm (0.43 inch), quadratically arranged, at distance of 72 mm (2.84 inch) | <ul style="list-style-type: none"> 1 Electrical connections 2 Equipotential bonding screw M5 3 Thread M20 x 1.5 or 1/2" NPT 4 Lock screw |
|---|--|

6 Ordering information

	Main order number							Add. order no.
	Version number	1	2	3	4	5	6	
TTF300 Field Mounted Temperature Transmitter, Pt100 (RTD), Thermocouples, Electrical Isolation	TTF300	X	X	X	X	X	X	XX
Explosion Protection								
Without explosion protection		Y	0					
ATEX Intrinsic Safety type of protection:		E	1					
Zone 0: II 1 G Ex ia IIC T6,								
Zone 1 (0): II 2 (1) G Ex [ia] ib IIC T6,								
Zone 1 (20): II 2 G (1D) Ex [iaD] ib IIC T6								
ATEX Non-sparking type of protection:		E	5					
Zone 2 / Zone 22: II 3 G Ex nA II T6 and II 3 D IP 65 T 135 °C (Not for application in hybrid mixtures)	1)							
ATEX Dust Explosion Protection:		D	1					
Zone 20: II 1 D IP 65 T 135 °C								
ATEX Dust Explosion Protection and Intrinsic Safety:		D	2					
Zone 0 / Zone 20: II 1 G Ex ia IIC T6 and II 1 D IP 65 T 135 °C (Not for application in hybrid mixtures)	1)							
ATEX Flameproof type of protection:		E	3					
Zone 1: II 2 G Ex d IIC T6								
ATEX Flameproof and Intrinsic Safety type of protection:		E	4					
Zone 1 / Zone 0: II 2 G Ex d IIC T6 and II 1 G Ex ia IIC T6								
IECEX Intrinsic Safety type of protection:		H	1					
Zone 0: Ex ia IIC T6,								
Zone 1 (0): Ex [ia] ib IIC T6,								
Zone 1 (20): Ex [iaD] ib IIC T6								
FM Intrinsic Safety (IS):		L	1					
Class I, Div. 1+2, Groups A, B, C, D, Class II, E, F, G, Class III, Class I, Zone 0, AEx ia IIC T6								
FM Non-incendive (NI):		L	2					
Class I, Div. 2, Groups A, B, C, D, Class II, E, F, G, Class III								
FM Explosionproof (XP):		L	3					
XP, NI, DIP, Class I, II, III, Div. 1+2, Groups A-G, factory sealed								
FM Explosionproof (XP) and Intrinsic Safety (IS):		L	7					
XP, NI, DIP, Class I, II, III, Div. 1+2, Groups A-G, factory sealed and IS, Class I, Div. 1+2, Groups A, B, C, D, Class II, E, F, G, Class III, Class I, Zone 0, AEx ia IIC T6								
CSA Intrinsic Safety (IS):		R	1					
Class I, Div. 1+2, Groups A, B, C, D, Class II, E, F, G, Class III								
CSA Non-incendive (NI):		R	2					
Class I, Div. 2, Groups A, B, C, D, Class II, E, F, G, Class III								
CSA Explosionproof (XP):		R	3					
XP, NI, DIP, Class I, II, III, Div. 1+2, Groups A-G, factory sealed								
CSA Explosionproof (XP) and Intrinsic Safety (IS):		R	7					
XP, NI, DIP, Class I, II, III, Div. 1+2, Groups A-G, factory sealed and IS, Class I, Div. 1+2, Groups A, B, C, D, Class II, E, F, G, Class III								
Russia - metrological approval	2)	G	1					
Russia - metrological approval and GOST Ex i	2)	G	2					
Russia - metrological approval and GOST Ex d	2)	G	7					
Russia - metrological approval and GOST Ex i and Ex d	2)	G	8					
Kazakhstan - metrological approval	2)	G	3					
Kazakhstan - metrological approval and GOST Ex i	2)	G	4					
Kazakhstan - metrological approval and GOST Ex d	2)	M	1					
Kazakhstan - metrological approval and GOST Ex i and Ex d	2)	M	2					
Ukraine - metrological approval	2)	G	5					
Ukraine - metrological approval and GOST Ex i	2)	G	6					
Ukraine - metrological approval and GOST Ex d	2)	G	9					
Ukraine - metrological approval and GOST Ex i and Ex d	2)	M	3					
Belarus - metrological approval	2)	M	5					
Belarus - metrological approval and GOST Ex i	2)	M	6					
Belarus - metrological approval and GOST Ex d	2)	M	7					
Belarus - metrological approval and GOST Ex i and Ex d	2)	M	8					

Continued on next page

	Main order number								Add. order no.
	Version number 1 – 6	7	8	9	10	11	12	13	
TTF300 Field Mounted Temperature Transmitter, Pt100 (RTD), Thermocouples, Electrical Isolation	TTF300	X	X	X	X	X	X	X	XX
Housing / Indicators									
Single-chamber housing (aluminum) / Without indicators				A					
Single-chamber housing (stainless steel) / Without indicators				B					
Single-chamber housing (aluminum) / with LCD indicator HMI				C					
Single-chamber housing (stainless steel) / with LCD indicator HMI				D					
Cable Entry									
Thread 2 x M20 x 1.5				3)	1				
Thread 2 x 1/2 in. NPT					2				
Thread 2 x 3/4 in. NPT				4)	3				
Cable gland 2 x M20 x 1.5				5)	4				
Communication Protocol									
HART						H			
PROFIBUS PA						P			
FOUNDATION Fieldbus						F			
Configuration									
Standard configuration							B	S	
Customer-specific configuration with report, except user curve						6)	B	F	
Customer-specific configuration with report, including user curve							B	G	
Certificates									
SIL2 - declaration of conformity								2)	CS
Declaration of compliance with the order 2.1 acc. EN 10204									C4
Inspection certificate 3.1 acc. EN 10204 for visual and functional test									C6
Calibration Certificates									
With 5-point factory certificate									EM
Inspection certificate 3.1 acc. EN 10204 for 5-point calibration									EP
Mounting Bracket									
Wall mounting / 2 in. pipe mounting bracket (stainless steel)									K2
Cable Entry Options									
Cable screw connection 2 x 1/2 in. NPT								7)	U5
Expanded Ambient Temperature Range									
-50 ... 85 °C (-58 ... 185 °F)								8)	SE
Device Identification Plate									
Stainless steel									T0
Additional Tag Plate									
Stainless steel									I1
Customer-specific Versions									
(Please provide details)									Z9
Language of Documentation									
German									M1
English									M5
Language package Western Europe / Scandinavia (Languages: DE, EN, DA, ES, FR, IT, NL, PT, FI, SV)									MW
Language package Eastern Europe (Languages: DE, EL, CS, ET, LV, LT, HU, PL, SK, SL, RO, BG)									ME

- 1) According EN 60079-0 and EN 61241-0, the application in hybrid mixtures (concomitance of potentially explosive dust and gas) is currently not allowed
- 2) Only available with Communication Protocol code H (HART)
- 3) Not available with Explosion Protection code L1, L2, L3, L7, R1, R2, R3, R7, D1, D2
- 4) Only available with Housing / Indicators code A, C
- 5) Not available with Explosion Protection code L3, L7, R3, R7, G7, G8, G9, M1, M2, M3, M7, M8
- 6) E.g., set measuring range, TAG no.
- 7) Only available with cable entry code 2
- 8) Not available with Explosion Protection code L1, L2, L3, L7, R1, R2, R3, R7, D1, D2, E3, E4, G7, G8, G9, M1, M2, M3, M7, M8

6.1 Documentation available for ordering

Description	Order number
TTF300 Documentation CD-ROM	3KXT221001R0800
TTF300 Commissioning Instructions, English	3KXT221001R4401
TTF300 Commissioning Instructions, German	3KXT221001R4403
TTF300 Commissioning Instructions, Language package Western Europe / Scandinavia	3KXT221001R4493
TTF300 Commissioning Instructions, Language package Eastern Europe	3KXT221001R4494

7 Ex relevant specifications

7.1 TTF300-E1X, intrinsic safety ATEX

Explosion protection

Approved for use in Zone 0, 1, and 2

Designation

II 1G Ex ia IIC T6 (Zone 0)
II 2(1)G Ex [ia] ib IIC T6 (Zone 1 [0])
II 2G(1D) Ex [iaD] ib IIC T6 (Zone 1 [20])

TTF300-E1H:

EC type-examination test certificate PTB 05 ATEX 2017 X

TTF300-E1P / E1F:

EC type-examination test certificate PTB 09 ATEX 2016 X

7.2 TTF300-H1X, intrinsic safety IECEx

Designation

Ex ia IIC T6
Ex [ia] ib IIC T6
Ex [iaD] ib IIC T6

TTF300-H1H:

IECEx certificate of conformity IECEx PTB 09.0014X

TTF300-H1P / H1F:

IECEx certificate of conformity

7.3 Safety specifications for Intrinsic Safety ATEX / IECEx

Temperature table

Temperature class	Permissible ambient temperature range	
	Device category 1 use	Device category 2 use
T6	-50 ... 44 °C (-58 ... 111,2 °F)	-50 ... 56 °C (-58 ... 132,8 °F)
T5	-50 ... 56 °C (-58 ... 132,8 °F)	-50 ... 71 °C (-58 ... 159,8 °F)
T4, T3, T2, T1	-50 ... 60 °C (-58 ... 140,0 °F)	-50 ... 85 °C (-58 ... 185,0 °F)

Intrinsic safety Ex ia IIC type of protection (part 1)

	TTF300-E1H TTF300-H1H Supply circuit	TTF300-E1P / -H1P TTF300-E1F / -H1F Supply circuit 1)	
		FISCO	ENTITY
Max. voltage	$U_i = 30 \text{ V}$	$U_i \leq 17.5 \text{ V}$	$U_i \leq 24.0 \text{ V}$
Short-circuit current	$I_i = 130 \text{ mA}$	$I_i \leq 183 \text{ mA}^{2)}$	$I_i \leq 250 \text{ mA}$
Max. power	$P_i = 0.8 \text{ W}$	$P_i \leq 2.56 \text{ W}^{2)}$	$P_i \leq 1.2 \text{ W}$
Internal inductance	$L_i = 0.5 \text{ mH}$	$L_i \leq 10 \mu\text{H}$	$L_i \leq 10 \mu\text{H}$
Internal capacitance	$C_i = 5 \text{ nF}$	$C_i \leq 5 \text{ nF}$	$C_i \leq 5 \text{ nF}$

1) FISCO in accordance with IEC 60079-27

2) II B FISCO: $I_i \leq 380 \text{ mA}$, $P_i \leq 5.32 \text{ W}$

Intrinsic safety Ex ia IIC type of protection (part 2)

	Measurement current circuit: resistance thermometers, resistors	Measurement current circuit: thermocouples, voltages
Max. voltage	$U_o = 6.5 \text{ V}$	$U_o = 1.2 \text{ V}$
Short-circuit current	$I_o = 25 \text{ mA}$	$I_o = 50 \text{ mA}$
Max. power	$P_o = 38 \text{ mW}$	$P_o = 60 \text{ mW}$
Internal inductance	$L_i = 0 \text{ mH}$	$L_i = 0 \text{ mH}$
Internal capacitance	$C_i = 49 \text{ nF}$	$C_i = 49 \text{ nF}$
Maximum permissible external inductance	$L_o = 5 \text{ mH}$	$L_o = 5 \text{ mH}$
Maximum permissible external capacitance	$C_o = 1.55 \mu\text{F}$	$C_o = 1.05 \mu\text{F}$

Intrinsic safety Ex ia IIC type of protection (part 3)

	LCD indicator interface
Max. voltage	$U_o = 6.2 \text{ V}$
Short-circuit current	$I_o = 65.2 \text{ mA}$
Max. power	$P_o = 101 \text{ mW}$
Internal inductance	$L_i = 0 \text{ mH}$
Internal capacitance	$C_i = 0 \text{ nF}$
Maximum permissible external inductance	$L_o = 5 \text{ mH}$
Maximum permissible external capacitance	$C_o = 1.4 \mu\text{F}$

7.4 TTF300-E5X, non-sparking + dust explosion protection ATEX

Explosion protection

Approved for use in Zone 2 and Zone 22

Designation

II 3G Ex nA II T6

II 3 D IP 65 T 135 °C

ABB manufacturer's declaration in accordance with ATEX Directive

Temperature table

Temperature class	Device category 3 use
T6	-50 ... 56 °C (-58 ... 132,8 °F)
T5	-50 ... 71 °C (-58 ... 159,8 °F)
T4	-50 ... 85 °C (-58 ... 185,0 °F)

7.5 TTF300-D1X, dust explosion protection ATEX

Explosion protection

Approved for use in Zone 20

Designation

II 1D Ex tD A20 IP66 T135°C

EC type-examination test certificate BVS 06 ATEX E 029

7.6 TTF300-D2X, dust explosion protection + intrinsic safety ATEX

Explosion protection

Approved for use in Zone 20 and Zone 0

Designation

II 1D Ex tD A20 P66 T135°C

II 1G Ex ia IIC T6

EC type-examination test certificate BVS 06 ATEX E 029

EC type-examination test certificate PTB 05 ATEX 2017 X

EC type-examination test certificate PTB 05 ATEX 2016 X

7.7 TTF300-E3X, flameproof enclosure ATEX

Explosion protection

Approved for use in Zone 1

Designation

II 2G Ex d IIC T6

EC type-examination test certificate PTB 99 ATEX 1144

7.8 TTF300-E4X, flameproof enclosure + intrinsic safety ATEX

Explosion protection

Approved for use in Zone 1

Designation

II 2G Ex d IIC T6

II 1G Ex ia IIC T6

EC type-examination test certificate PTB 99 ATEX 1144

EC type-examination test certificate PTB 05 ATEX 2017 X

EC type-examination test certificate PTB 05 ATEX 2016 X

7.9 TTF300-L1X, intrinsically safe FM

Class I, Div. 1 + 2, Groups A, B, C, D

Class I, Zone 0, AEx ia IIC

TTF300-L1H: Control Drawing: SAP_214832

TTF300-L1P: Control Drawing: TTF300-L1..P (IS)

TTF300-L1F: Control Drawing: TTF300-L1..F (IS)

7.10 TTF300-L2X, non-incendive FM

Class I, Div. 2, Groups A, B, C, D

Class I Zone 2 Group IIC T6

TTF300-L2H:

Control Drawing: SAP_214828

Control Drawing: SAP_214830

TTF300-L2P:

Control Drawing: TTF300-L2..P (NI_PS), TTF300-L2..P (NI_AA)

TTF300-L2F:

Control Drawing: TTF300-L2..F (NI_PS), TTF300-L2..F (NI_AA)

7.11 TTF300-L3X, explosion proof FM

XP,NI, DIP Class I, II, III, Div. 1 + 2, Groups A-G, factory sealed

7.12 TTF300-L7X, explosion proof + intrinsically safe FM

XP, NI, DIP Class I, II, III, Div. 1 + 2, Groups A-G, factory sealed

Class I, Div. 1 + 2, Groups A, B, C, D

Class I, Zone 0, AEx ia IIC T6

TTF300-L1H: Control Drawing: SAP_214832

TTF300-L1P: Control Drawing: TTF300-L1..P (IS)

TTF300-L1F: Control Drawing: TTF300-L1..F (IS)

7.13 TTF300-R1X, intrinsically safe CSA

Class I, Div. 1 + 2, Groups A, B, C, D

Class I, Zone 0, Ex ia IIC

TTF300-R1H: Control Drawing: SAP_214825

TTF300-R1P: Control Drawing: TTF300-R1..P (IS)

TTF300-R1F: Control Drawing: TTF300-R1..F (IS)

7.14 TTF300-R2X, non-incendive CSA

Class I, Div. 2, Groups A, B, C, D

TTF300-R2H:

Control Drawing: SAP_214827

Control Drawing: SAP_214895

TTF300-R2P:

Control Drawing: TTF300-R2..P (NI_PS), TTF300-R2..P (NI_AA)

TTF300-R2F:

Control Drawing: TTF300-R2..F (NI_PS), TTF300-R2..F (NI_AA)

7.15 TTF300-R3X, explosion proof CSA

XP,NI, DIP Class I, II, III, Div. 1 + 2, Groups A-G, factory sealed

7.16 TTF300-R7X, explosion proof + intrinsically safe CSA

XP,NI, DIP Class I, II, III, Div. 1 + 2, Groups A-G, factory sealed

Class I, Div. 1 + 2, Groups A, B, C, D

Class I, Zone 0, Ex ia Group IIC T6

TTF300-R1H: Control Drawing: SAP_214825

TTF300-R1P: Control Drawing: TTF300-R1..P (IS)

TTF300-R1F: Control Drawing: TTF300-R1..F (IS)

8 Type B LCD

CE marking

The type B LCD indicator meets all requirements as regards the CE marking in accordance with IEC 61326 (2005).

8.1 Features

Transmitter-controlled graphic (alphanumeric) LCD indicator

- Character height, mode-dependent
- Sign, 4 digits, 2 decimal places
- Bar graph display

Display options

- Sensor 1 process value
- Sensor 2 process value
- Electronics / ambient temperature
- Output value
- Output %

Display diagnostic information related to transmitter and sensor status

8.2 Specifications

Temperature range

- 20 ... 70 °C (-4 ... 158 °F)
- Restricted display function (contrast, reaction time) in the temperature ranges:
- 50 ... -20 °C (-58 ... -4 °F)
- and
- 70 ... 85 °C (158 ... 185 °F)

Humidity

0 ... 100 %, condensation permitted

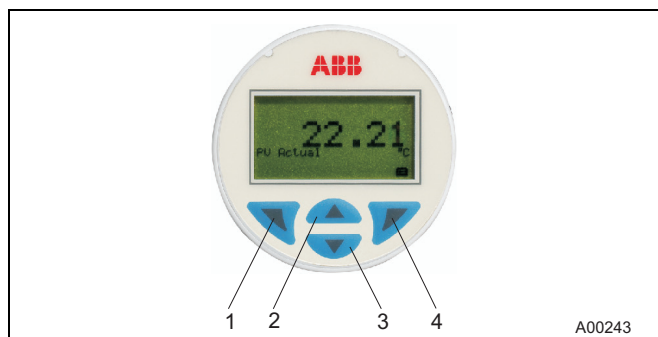

Fig. 8: Type B LCD indicator

- | | |
|-----------------|------------------|
| 1 Exit / Cancel | 3 Scroll forward |
| 2 Scroll back | 4 Select |

8.3 Configuration function

Sensor configuration for standard sensors

Measuring range

Behavior in the event of a fault (HART)

Software-write protection for configuration data

Device address for HART and PROFIBUS PA

8.4 Ex relevant specifications

8.4.1 Intrinsic safety ATEX

Explosion protection

Approved for use in Zone 0

Designation

II 1G Ex ia IIC T6

EC type-examination test certificate PTB 05 ATEX 2079 X

8.4.2 Intrinsic safety IECEx

Explosion protection

Approved for use in Zone 0

Designation

Ex ia IIC T6

IECEx certificate of conformity IECEx PTB

8.4.3 Safety specifications for intrinsic safety ATEX / IECEx

Temperature table

Temperature class	Permissible ambient temperature range	
	Device category 1 use	Device category 2 use
T6	-40 ... 44 °C (-40 ... 111.2 °F)	-40 ... 56 °C (-40 ... 132.8 °F)
T5	-40 ... 56 °C (-40 ... 132.8 °F)	-40 ... 71 °C (-40 ... 159.8 °F)
T4	-40 ... 60 °C (-40 ... 140 °F)	-40 ... 85 °C (-40 ... 185 °F)

Protection type intrinsic safety Ex ia IIC

	Supply circuit
Max. voltage	U _i = 9 V
Short circuit current	I _i = 65.2 mA
Max. power	P _i = 101 W
Internal inductance	L _i = 0 mH
Internal capacitance	C _i = 0 nF

8.4.4 Intrinsically Safe FM

I.S. Class I Div 1 and Div 2, Group: A, B, C, D or
I.S. Class I Zone 0 AEx ia IIC T*
Temp. Ident: T6 T_{amb} 56 °C, T4 T_{amb} 85 °C
 $U_i / V_{max} = 9V$, $I_i / I_{max} < 65.2 \text{ mA}$, $P_i = 101 \text{ mW}$
 $C_i = 0.4 \mu\text{F}$; $L_i = 0$
Control Drawing: SAP_214 748

8.4.5 Non-Incendive FM

N.I. Class I Div 2, Group: A, B, C, D or
Ex nL IIC T*, Class I Zone 2
Temp. Ident: T6 T_{amb} 60 °C, T4 T_{amb} 85 °C
 $U_i / V_{max} = 9V$, $I_i / I_{max} < 65.2 \text{ mA}$, $P_i = 101 \text{ mW}$
 $C_i = 0.4 \mu\text{F}$; $L_i = 0$
Control Drawing: SAP_214 751

8.4.6 Intrinsically Safe CSA

I.S. Class I Div 1 and Div 2; Group: A, B, C, D or
I.S. Zone 0 Ex ia IIC T*
*Temp. Ident T6 T_{amb} 56 °C, T4 T_{amb} 85 °C
 $U_i / V_{max} = 9V$, $I_i / I_{max} < 65.2 \text{ mA}$, $P_i = 101 \text{ mW}$
 $C_i < 0.4 \mu\text{F}$, $L_i = 0$
Control Drawing: SAP_214 749

8.4.7 Non-Incendive CSA

N.I. Class I Div 2, Group: A, B, C, D or
Ex nL IIC T*, Class I Zone 2
*Temp. Ident T6, T_{amb} 60 °C, T4 T_{amb} 85 °C
 $U_i / V_{max} = 9V$, $I_i / I_{max} < 65.2 \text{ mA}$, $P_i = 101 \text{ mW}$
 $C_i < 0.4 \mu\text{F}$, $L_i = 0$
Control Drawing: SAP_214 750

Contact us

ABB Ltd.

Salterbeck Trading Estate
Workington, Cumbria
CA14 5DS
UK
Phone: +44 (0)1946 830 611
Fax: +44 (0)1946 832 661

ABB Inc.

125 E. County Line Road
Warminster PA 18974
USA
Phone: +1 215 674 6000
Fax: +1 215 674 7183

ABB Automation Products GmbH

Schillerstr. 72
32425 Minden
Germany
Phone: +49 551 905-534
Fax: +49 551 905-555

www.abb.com

Note

We reserve the right to make technical changes or modify the contents of this document without prior notice. With regard to purchase orders, the agreed particulars shall prevail. ABB does not accept any responsibility whatsoever for potential errors or possible lack of information in this document.

We reserve all rights in this document and in the subject matter and illustrations contained therein. Any reproduction, disclosure to third parties or utilization of its contents - in whole or in parts - is forbidden without prior written consent of ABB.

Copyright© 2011 ABB
All rights reserved

3KXT221001R1001