

RHD4000 (Confrac) Electrical Part-Turn Actuator



For continuous positioning,
Rated torque 4000 Nm (3000 lbf-ft)

Electrical actuator for continuous positioning or step control

Stall proof without the need of position or torque dependent switch-off

Three-phase asynchronous motor

Sturdy gear unit with highly efficient design

Adjustable mechanical limit stops for defined operating range

Hand wheel for emergency operation

Integrated sensors for position and temperature

Signal and power input only via separate, microprocessor-controlled power electronics

Voltage supply 115 V AC or 230 V AC only via special power electronics

Contents

1	Concept	3
2	Technical data	3
2.1	Actuator	3
2.2	General information.....	3
2.3	24-pole plug on the actuator	4
2.4	Tapped holes for cable glands	4
3	Electrical connection	5
3.1	Power Electronic Unit EBN853 (Contrac) / EBN861 (Contrac).....	5
3.2	Power Electronic Unit EBS852 (Contrac) / EBS862 (Contrac)	7
4	Dimensions	8
4.1	Part-turn actuators.....	8
4.2	Lever.....	10
5	Ordering information	12
5.1	Electrical Part-Turn Actuator RHD 4000 (Contrac).....	12

1 Concept

Compact actuator for the operation of final control elements with preferably 90° rotary movement such as flaps, cocks, etc.

The torque is transferred via a lever / linkage bar assembly or the actuator is directly coupled to the cock flange.

A special power electronic unit controls the actuator. The electronic unit serves as the interface between actuator and control system.

During continuous positioning the power electronic unit varies the motor torque steplessly until the actuator force and the restoring

process forces are balanced. High response sensitivity and high positioning accuracy with short positioning time ensure an excellent control quality and a long actuator life.



Note

The ANSI information appears in parentheses after the SI-information.

2 Technical data

2.1 Actuator

Model	RHD4000-10	RHD4000-40
Rated torque	4000 Nm (3000 lbf-ft) (adjustable to 0.5 / 0.75 or 1x rated torque)	
Starting torque	1.2 x rated torque (break-away torque in end positions for short time 2 x rated torque)	
Rated time for 90°	10 ... 900 s	40 ... 900 s
Operating speed, adjustable	9.0 ... 0.1 °/s	2.25 ... 0.1 °/s
Operating angle	Typically 90° (min. 35°, max. 270°). See instructions for limited operating angle if actuator is equipped with lever and limit stop.	
Weight	approx. 270 kg (595 lb)	approx. 265 kg (584 lb)
Related electronics		
For field installation:	Model EBN861 ¹⁾	Model EBN853 ³⁾
For rack installation:	Model EBS862 ²⁾	Model EBS852 ⁴⁾
Motor type	MC 100 BA	MC 90 BA
Sensors	Position and temperature sensor always available.	

¹⁾ Data sheet EBN861:10/68-8.22

²⁾ Data sheet EBS862:10/68-8.25

³⁾ Data sheet EBN853: 10/68-8 27

⁴⁾ Data sheet EBS852: 10/68-8 24

2.2 General information

	RHD4000
Operating mode	S9 - 100%; stall proof acc. to IEC 60034-1 / EN 60034-1
Protection class	IP 66
Humidity	≤ 95% average; condensation not permitted
Ambient temperature	-10 ... 65° C (15 ... 150° F) -30 ... 50° C (-20 ... 130° F)
Mounting position	any position; preferably IMB 3 acc. to IEC 60034-7 / EN 60034-7
Coating	2-layer component epoxy (RAL 9005; black)
Anti-condensation heater	Motor: Directly power feed from Contrac electronic unit. Signal space: Separate heating resistor; separate power supply or power feed from Contrac electronic unit.
Electrical connection	Plug with crimp snap-in contacts or terminals. Connecting cable electronics – actuator optionally (see ordering information of electronics).
Power supply for motor and sensors	Only via Contrac electronic unit (see data sheet of electronic unit).

2.3 24-pole plug on the actuator

	Crimp pins	Terminals (Option)
Cable gauge:	Motor, heater: 1.5 mm ² (16 AWG) Signals: 0.5 mm ² (20 AWG)	2.5 mm ² (14 AWG)
Contact surface	Gold-plated	Motor, signal: Gold-plated Heater: Silver-plated

2.4 Tapped holes for cable glands

Tapped holes for cables	optional adapters*	
M20 x 1.5 (2x)	PG 16 (2x)	NPT ½" (2 x)
M25 x 1.5 (1 x)	PG 21 (2x)	NPT ¾" (1 x)

* Adapter for PG or NPT thread must be ordered separately

3 Electrical connection

3.1 Power Electronic Unit EBN853 (Contrac) / EBN861 (Contrac)

3.1.1 Analog / digital



Note

The electrical connection is provided by a plug on the actuator and the terminals on the electronic unit.

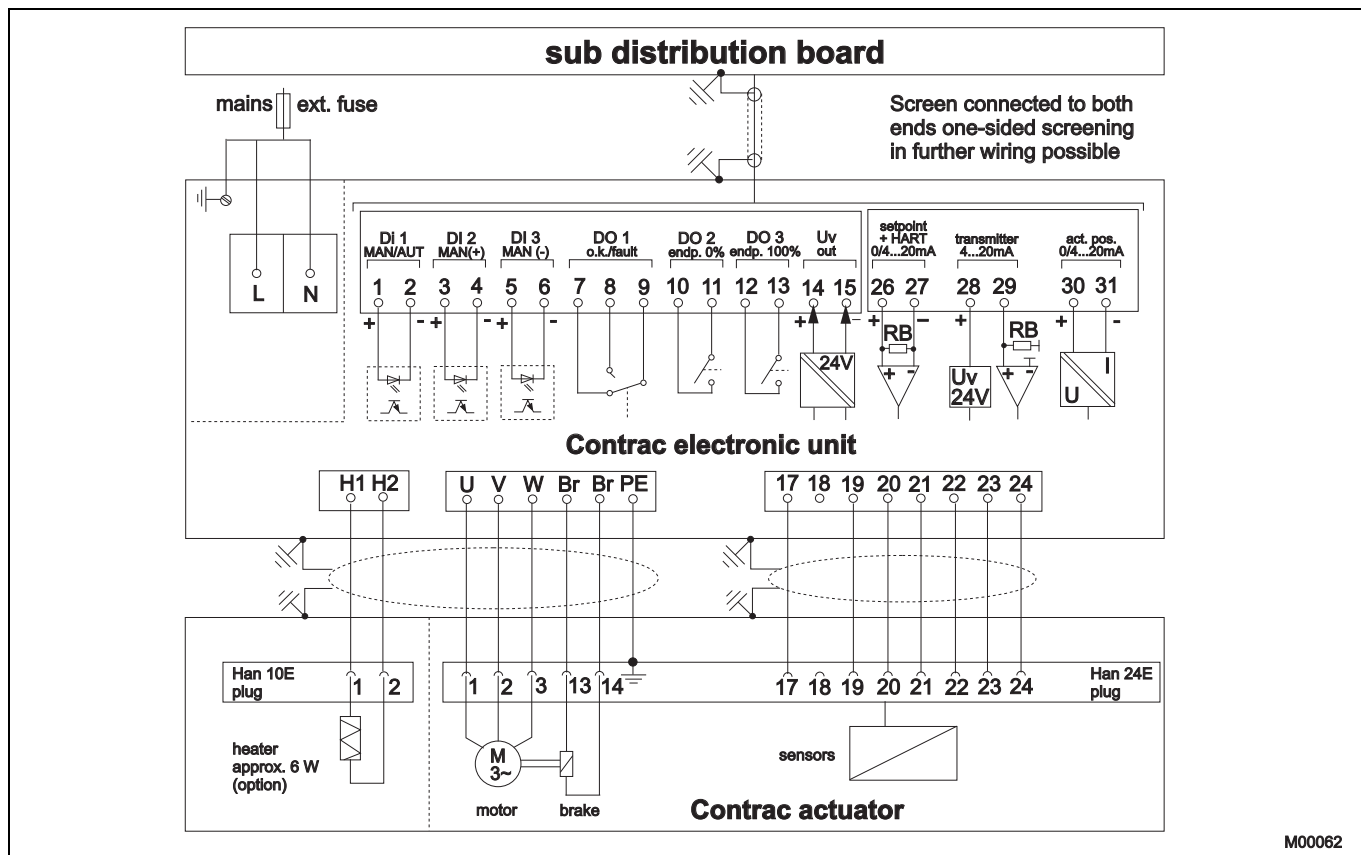

M00062

Fig. 1

3.1.2 PROFIBUS DP

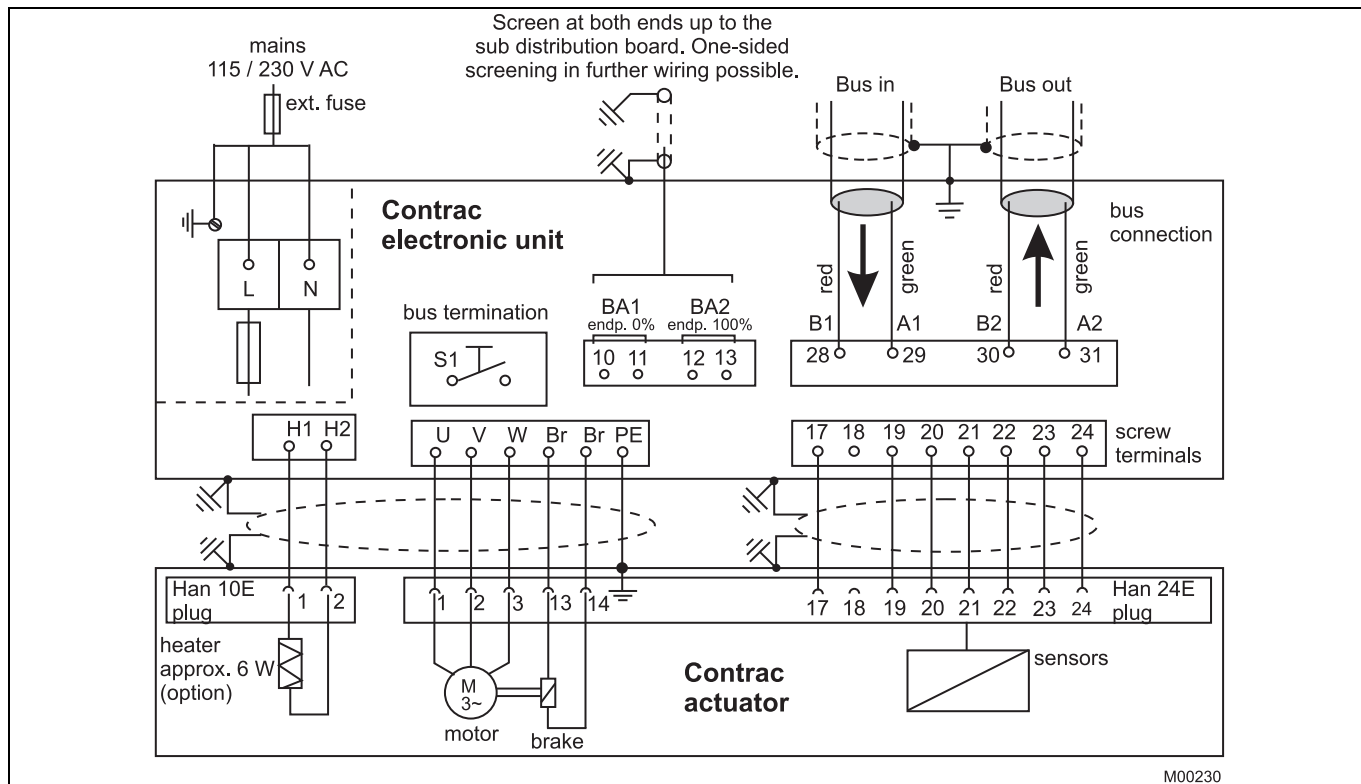

Fig. 2

M00230

3.2 Power Electronic Unit EBS852 (Contrac) / EBS862 (Contrac)

3.2.1 Analog / digital



Note

The electrical connection is provided by a plug on the actuator and the terminals on the electronic unit.

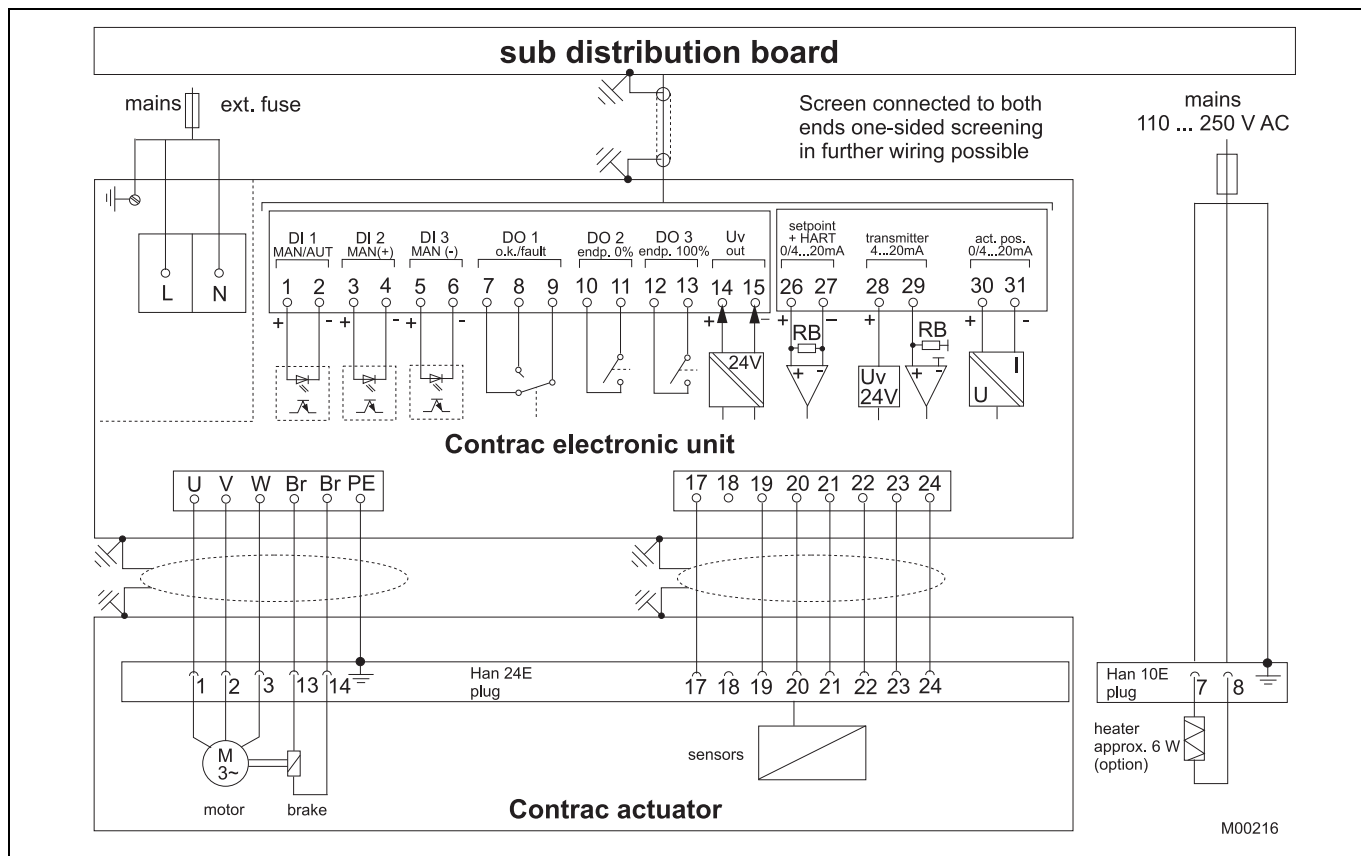
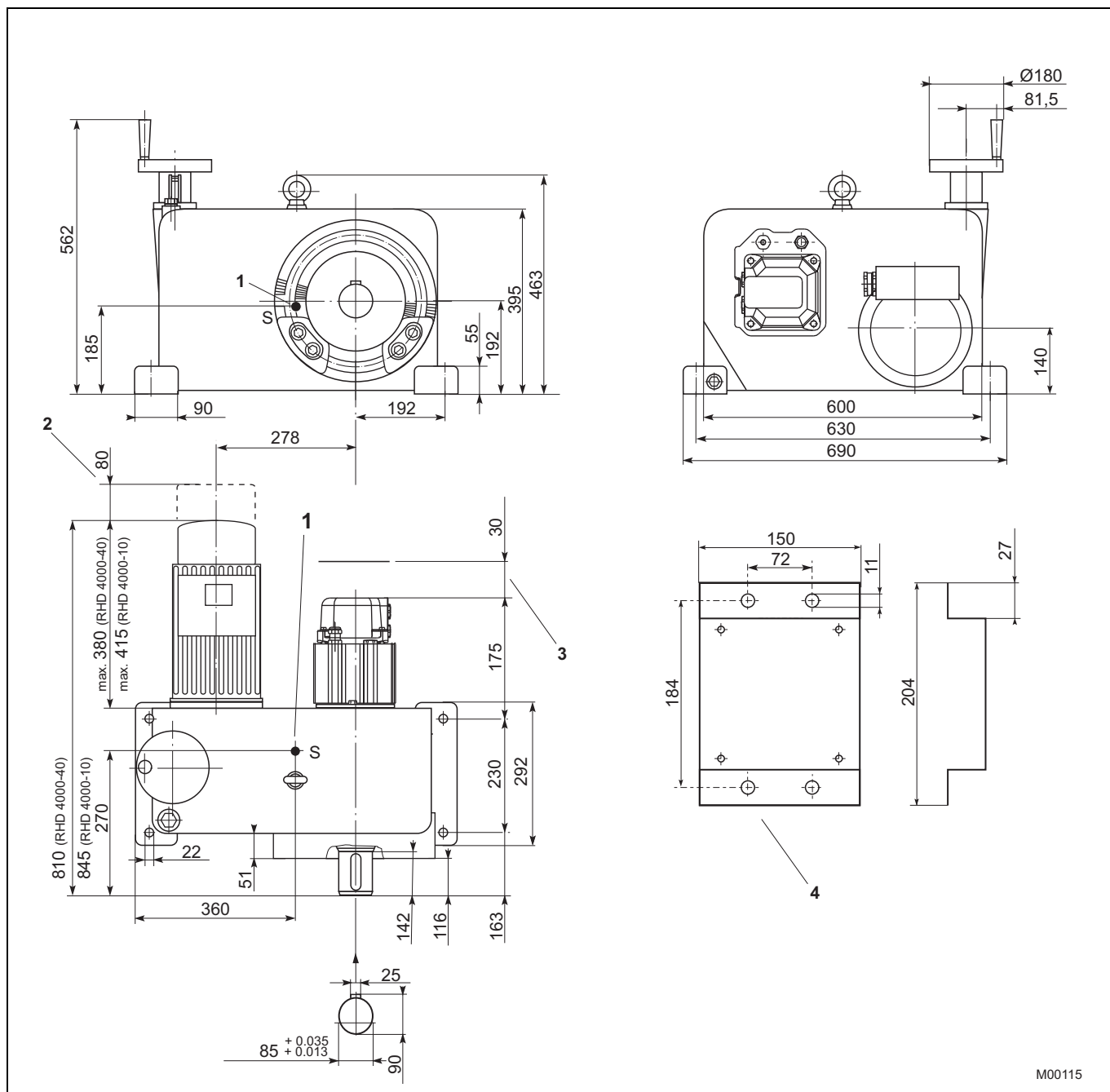

Fig. 3

4 Dimensions

4.1 Part-turn actuators



M00115

Fig. 4 Dimensions in mm

- 1 S = Center of gravity
- 2 Removal space

- 3 Space for removing the plug
- 4 Plug holder (not to scale)

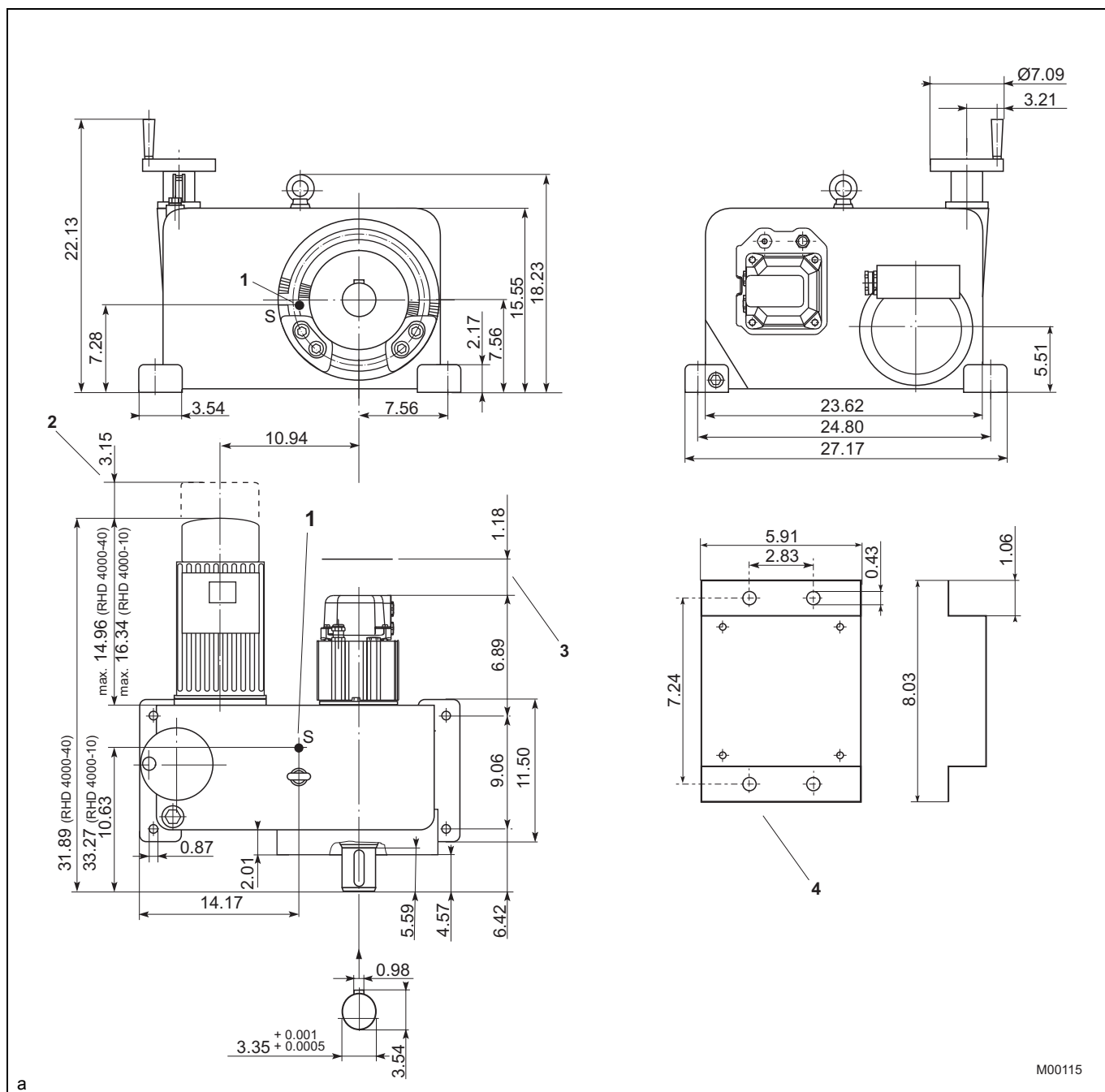

M00115

Fig. 5 Dimensions in Inch

- 1 S = Center of gravity
- 2 Removal space

- 3 Space for removing the plug
- 4 Plug holder (not to scale)

4.2 Lever

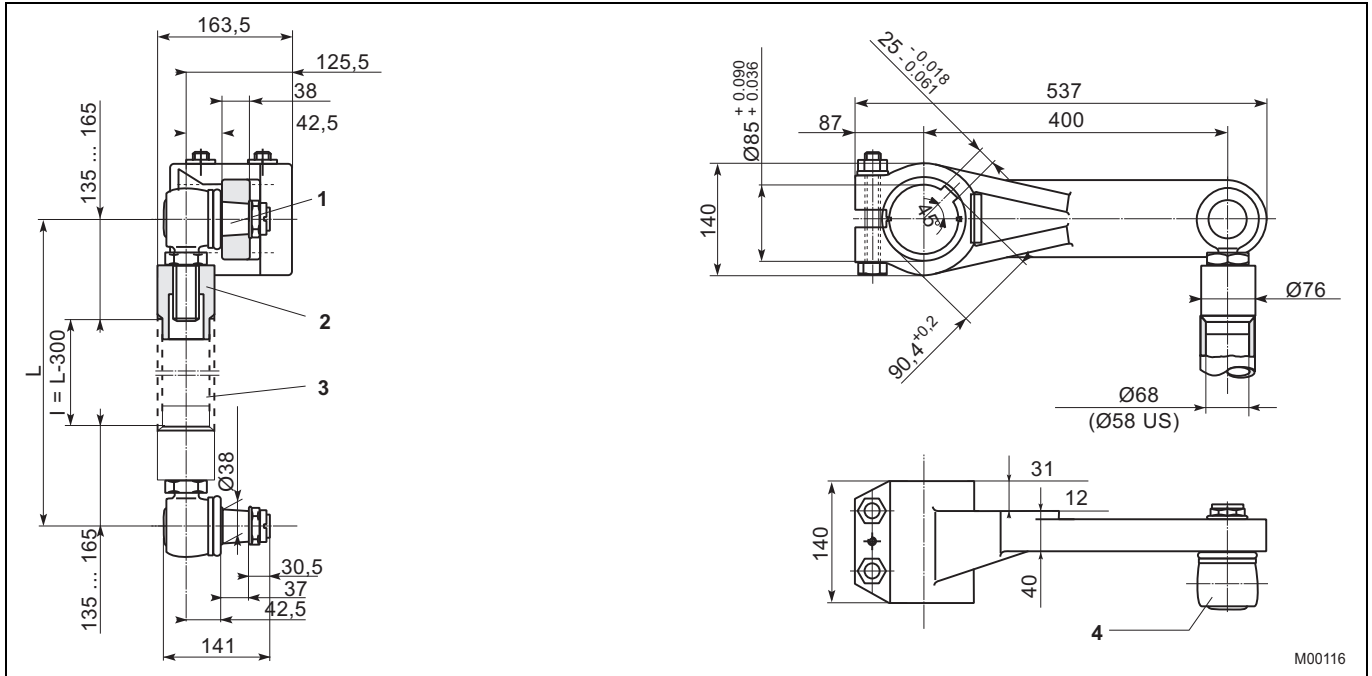

Fig. 6 Dimensions in mm

- 1 Cone 1 : 10
- 2 Welding bushings are part of shipment
- 3 Connection pipe 2 1/2" DIN 2440 resp. 2 1/2" schedule 80 pipe size "L" acc. to requirements. The pipe is not included in shipment.
- 4 Angular deflection of ball and socket joint:
 Pointing towards the actuator: max. 3°
 Pointing away from the actuator: max. 10°

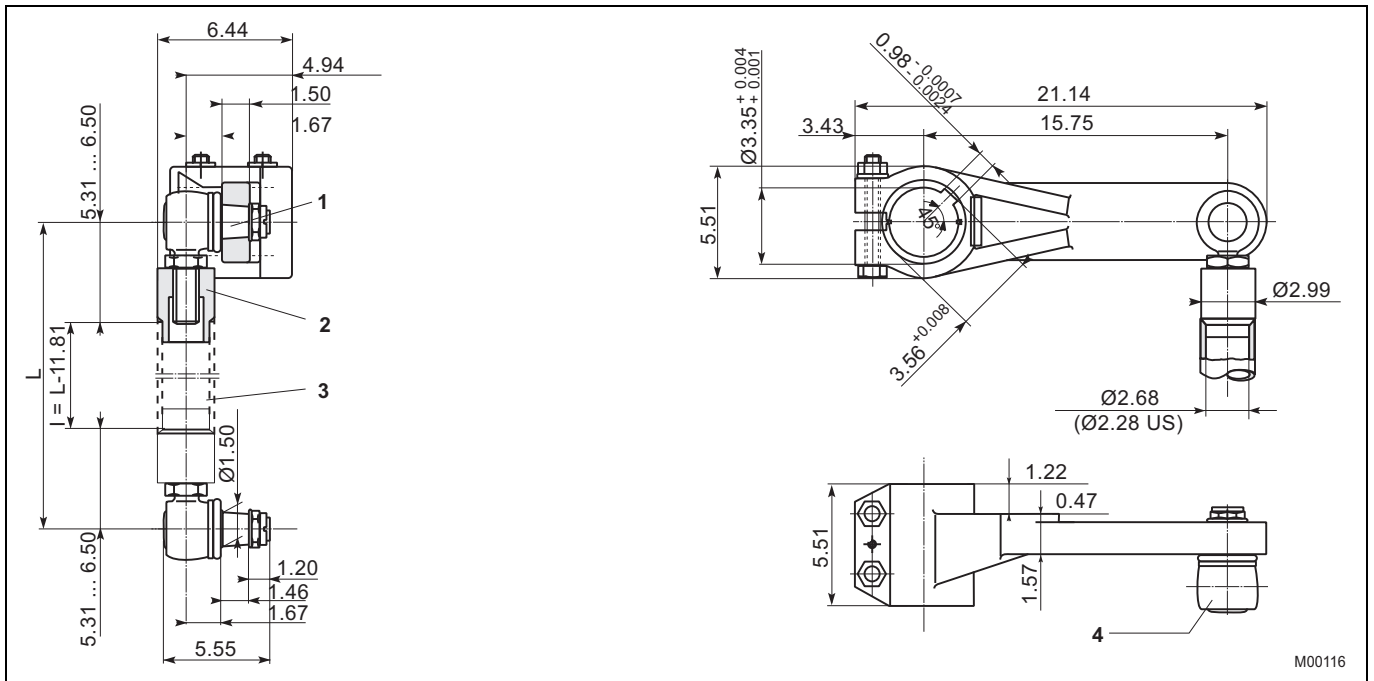

Fig. 7 Dimensions in Inch

- 1 Cone 1 : 10
- 2 welding bushings are part of shipment
- 3 Connection pipe 2 1/2" DIN 2440 resp. 2 1/2" schedule 80 pipe size "L" acc. to requirements. The pipe is not included in shipment.
- 4 Angular deflection of ball and socket joint:
 Pointing towards the actuator: max. 3°
 Pointing away from the actuator: max. 10°

5 Ordering information

5.1 Electrical Part-Turn Actuator RHD 4000 (Contrac)

Ordering information										
Part-Turn Actuator		Variant digit No.	1 - 7	8	9	10 11	Code			
RHD4000 -10, RHD4000-40		Catalog No.	V68181-							
Rated torque		4000 Nm (3000 ft-lbs) (adjustable to 50%/75%/100%)								
Rated pos. speed										
2.25°/s (adjustable to 2.25 ... 0.1°/s)		only for RHD4000-40		0	1	1	6			
9.0°/s (adjustable to 9.0 ... 0.1°/s)		only for RHD4000-10		0	1	1	7			
Special actuator features										
Select at least one feature per group										
Mechanical connection										
Shaft with key							370			
Lever set, standard design (consists of lever, 2 ball-and-socket joints and 2 welding bushings)							496			
Lever set, US design (consists of lever, 2 ball-and-socket joints and 2 US welding bushings)							374			
Electrical connection										
plug (24-pole) complete, crimped							277			
plug (24-pole) complete, terminals							278			
plug bottom part covered 1)							279			
Ambient temperature range										
-10 ... 65 °C (15 ... 150 °F)							344			
-30 ... 50 °C (-20 ... 130 °F)							341			

Additional ordering information										
							Code			
Electrical connection thread		set NPT adapter (junction metric / NPT thread)					680			
		set PG adapter (junction metric / PG thread)					681			
Anti condensation heater								360		
Identification on data label		(alphanumeric, max. 32 characters)						294		
Data label with US units								253		
Accessories		cover for male plug (24 pole)						337		
Accessories		plug holder						338		
Certificates		Factory certificate 2.1 acc. to EN 10204						291		
Certificates		Certificate B acc. to EN 10204						292		
Assembly with valve at ABB		(order and pos. no. of valve required)						481		
Operating instruction		(specify total quantity required, 1 copy without extra charge)								
German		(no specification for 1 copy)						Z1D		
English		(always state Code-No.)						Z1E		

1) female plug with cables to be ordered with electronic unit

Attention!

Electronic unit to be ordered separately

Note: Delivery time for max. 2 pcs. For 3 pcs. or more delivery time on request.

Contact us

ABB Ltd.

Process Automation

Salterbeck Trading Estate
Workington, Cumbria
CA14 5DS
UK

Phone: +44 (0)1946 830 611

Fax: +44 (0)1946 832 661

ABB Inc.

Process Automation

125 E. County Line Road
Warminster, PA 18974
USA

Phone: +1 215 674 6000

Fax: +1 215 674 7183

ABB Automation Products GmbH

Process Automation

Schillerstr. 72
32425 Minden
Germany

Phone: +49 551 905-534

Fax: +49 551 905-555

www.abb.com

Note

We reserve the right to make technical changes or modify the contents of this document without prior notice. With regard to purchase orders, the agreed particulars shall prevail. ABB does not accept any responsibility whatsoever for potential errors or possible lack of information in this document.

We reserve all rights in this document and in the subject matter and illustrations contained therein. Any reproduction, disclosure to third parties or utilization of its contents - in whole or in parts - is forbidden without prior written consent of ABB.

Copyright© 2010 ABB

All rights reserved