

**EN**  
English

**Commissioning Instruction**  
Mass Flowmeter  
CoriolisMaster FCM2000



**HART**   
COMMUNICATION PROTOCOL

**PROFI**  
process field bus  
**BUS**

 **Fieldbus**  
Foundation

**ABB**



# Mass Flowmeter CoriolisMaster FCM2000

## Commissioning Instruction - EN

CI/FCM2000-EN

10.2011

Rev. B

Translation of the original instruction

### Manufacturer:

#### **ABB Automation Products GmbH**

Dransfelder Straße 2  
D-37079 Göttingen  
Germany  
Tel.: +49 551 905-534  
Fax: +49 551 905-555

#### **Customer service center**

Phone: +49 180 5 222 580  
Fax: +49 621 381 931-29031  
[automation.service@de.abb.com](mailto:automation.service@de.abb.com)

© Copyright 2011 by ABB Automation Products GmbH  
Subject to changes without notice

This document is protected by copyright. It assists the user in safe and efficient operation of the device. The contents of this document, whether whole or in part, may not be copied or reproduced without prior approval by the copyright holder.

## Contents

<b>1</b>	<b>Safety</b> .....	<b>3</b>
1.1	General information and notes for the reader .....	3
1.2	Intended use.....	4
1.3	Improper use .....	4
1.4	Technical limit values .....	4
1.5	Approved media .....	5
1.6	Target groups and qualifications .....	5
1.7	Safety instructions for transport .....	5
1.8	Safety instructions for electrical installation .....	6
1.9	Safety instructions for operation.....	6
<b>2</b>	<b>Design and function</b> .....	<b>7</b>
2.1	ATEX and IECEx device overview .....	7
<b>3</b>	<b>Transport</b> .....	<b>8</b>
3.1	Inspection .....	8
3.2	General information on transport .....	8
3.3	Transporting MS2 devices of nominal size "U" (DN 6, 1/4") .....	8
<b>4</b>	<b>Installation</b> .....	<b>9</b>
4.1	Electrical connection .....	9
4.1.1	Electrical connections between the transmitter and the flowmeter sensor.....	9
4.1.2	Electrical connections between the transmitter and the peripherals .....	12
4.2	Ex relevant specifications.....	16
4.2.1	ATEX/IECEx Ex approval.....	19
<b>5</b>	<b>Commissioning</b> .....	<b>23</b>
5.1	General information.....	23
5.2	Information for safe operation – ATEX, IECEx .....	24
5.2.1	Inspection .....	24
5.2.2	Output Circuits .....	24
5.2.3	NAMUR Contact.....	25
5.2.4	Isolation: MC26., MC27.....	26
5.2.5	Information on changing the installation .....	27
<b>6</b>	<b>Parameterization</b> .....	<b>29</b>
6.1	Data entry .....	29
6.2	Entering data in short form.....	31
<b>7</b>	<b>Appendix</b> .....	<b>32</b>
7.1	Other applicable documents .....	32
7.2	Approvals and certifications .....	32

## 1 Safety

### 1.1 General information and notes for the reader

Read these instructions carefully prior to installing and commissioning the device.

These instructions are an important part of the product and must be kept for later use.

These instructions are intended as an overview and do not contain detailed information on all designs for this product or every possible aspect of installation, operation and maintenance.

For additional information or in case specific problems occur that are not discussed in these instructions, contact the manufacturer.

The content of these instructions is neither part of any previous or existing agreement, promise or legal relationship nor is it intended to change the same.

This product is built based on state-of-the-art technology and is operationally safe. It has been tested and left the factory in a safe, maintenance-free state. The information in the manual must be observed and followed in order to maintain this state throughout the period of operation.

Modifications and repairs to the product may only be performed if expressly permitted by these instructions.

Only by observing all of the safety information and all safety/warning symbols in these instructions can optimum protection of both personnel and the environment, as well as safe and fault-free operation of the device, be ensured.

Information and symbols directly on the product must be observed. They may not be removed and must be fully legible at all times.



#### Important

- An additional document with Ex safety information is available for measuring systems that are used in potentially explosive areas (Applies to FM / CSA only).
- Ex safety information is an integral part of this manual. As a result, it is crucial that the installation guidelines and connection values it lists are also observed.

The icon on the name plate indicates the following:



## 1.2 Intended use

This device is intended for the following uses:

- To convey liquids and gases (fluids), including unstable ones
- To meter the mass flow of the fluid directly
- To meter the volumetric flow of the fluid (indirectly via mass flow and density)
- To measure fluid density
- To measure fluid temperature

The following items are included in the intended use:

- Read and follow the instructions in this manual.
- Observe the technical ratings; refer to the section 1.4 „Technical limit values“.
- Use only allowed liquids for measurement; refer to the section 1.5 „Approved media“.

## 1.3 Improper use

The following are considered to be instances of improper use of the device:

- Operation as a flexible adapter in piping, e.g., to compensate for pipe offsets, pipe vibrations, pipe expansions, etc.
- As a climbing aid, e. g., for mounting purposes
- As a support for external loads, e. g., as a support for piping, etc.
- Adding material, e. g., by painting over the name plate or welding/soldering on parts
- Removing material, e. g., by spot drilling the housing

Repairs, alterations, and enhancements, or the installation of replacement parts, are only permissible insofar as these are described in the manual. Approval by ABB Automation Products GmbH must be sought for any activities beyond this scope. Repairs performed by ABB-authorized specialist shops are excluded from this.

## 1.4 Technical limit values

The meter has been designed for use exclusively within the values stated on the name plate and within the technical limit values specified on the data sheets.

The following technical limit values must be observed:

- The permissible pressure (PS) and the permissible fluid temperature (TS) must not exceed the pressure/temperature ratings (see the section titled "Specifications").
- The maximum and minimum operating temperature limits must not be exceeded or undershot.
- The permissible operating temperature must not be exceeded.
- The housing protection type must be observed during operation.
- The flowmeter sensor must not be operated in the vicinity of powerful electromagnetic fields, e.g., motors, pumps, transformers, etc. A minimum spacing of approx. 1 m (3.28 ft) must be maintained. For installation on steel parts (e.g., steel brackets), a minimum spacing of 100 mm (4") must be maintained. (These values have been calculated on the basis of IEC 801-2 and IEC TC77B.)

## 1.5 Approved media

When using media, please note:

- Media (fluids) may only be used if, based on the state of the art or the operating experience of the user, it can be assured that chemical and physical properties of the components coming into contact with the fluids will not be adversely affected during the operating period.
- Specifically chloride media can cause not visible corrosion damages to all media wetted components so that fluid can lead. The suitability of these materials for each application by the operator to examine.
- Media (fluids) with unknown properties or abrasive media may only be used if the operator can perform regular and suitable tests to ensure the safe condition of the meter.
- Observe the information on the name plate.

## 1.6 Target groups and qualifications

Installation, commissioning, and maintenance of the product may only be performed by trained specialist personnel who have been authorized by the plant operator to do so. The specialist personnel must have read and understood the manual and comply with its instructions.

Prior to using corrosive and abrasive materials for measurement purposes, the operator must check the level of resistance of all parts coming into contact with the materials to be measured. ABB Automation Products GmbH will gladly support you in selecting the materials, but cannot accept any liability in doing so.

The operators must strictly observe the applicable national regulations with regards to installation, function tests, repairs, and maintenance of electrical products.

## 1.7 Safety instructions for transport

Observe the following instructions:

- The center of gravity is off center.
- The flow direction must correspond to the direction indicated on the device, if labeled.
- Comply with the maximum torque for all flange connections.
- Install the devices without mechanical tension (torsion, bending).
- Install flange devices with coplanar counter flanges.
- Only install devices for the intended operating conditions and with suitable seals.
- Secure the flange bolts and nuts against pipeline vibrations.

### 1.8 Safety instructions for electrical installation

The electrical connection may only be made by authorized specialist personnel according to the electrical plans.

The electrical connection information in the manual must be observed; otherwise, the electrical protection type may be adversely affected.

Ground the measurement system according to requirements.

### 1.9 Safety instructions for operation

During operation with hot fluids, contact with the surface may result in burns.

Aggressive fluids may result in corrosion or abrasion of the parts that come into contact with the medium. As a result, pressurized fluids may escape prematurely.

Wear to the flange gasket or process connection gaskets (e.g., aseptic threaded pipe connections, Tri-Clamp, etc.) may enable a pressurized medium to escape.

When using internal flat gaskets, these can become embrittled by CIP/SIP processes.



#### **Warning – Risk to persons!**

Bacteria and chemical substances can contaminate or pollute pipeline systems and the materials they are made of.

The appropriate installation conditions must be observed in order to achieve an installation that complies with EHEDG requirements.

For an installation to comply with EHEDG requirements, the process connection/gasket combinations created by the operator must always be made of parts that conform to EHEDG stipulations (EHEDG Position Paper: "Hygienic Process connections to use with hygienic components and equipment").

**2 Design and function**



**Important**

An additional document with Ex safety instructions is available for measuring systems that are used in explosion hazardous areas (Applies to FM / CSA only).

As a result, it is crucial that the specifications and data it lists are also observed.

**2.1 ATEX and IECEx device overview**

Type	Standard/non-Ex MC23 A, U		Zone 2/21, 22 MC23 M, N		Zone 1/21 MC27 B, E	
1. Integral mount design - Standard/non-Ex - Ex Zone 2/21, 22 - Ex Zone 1/21						
2. Remote mount design Transmitter and flowmeter sensor - Standard/non-Ex - Ex Zone 1/21	ME21 A, U	MC21 A, U	ME21 M, N	MC21 M, N	ME26 B, E	MC26 B, E
3. Remote mount design Transmitter - Standard/non-Ex - Ex Zone 2/21, 22 Flowmeter sensor - Ex Zone 1/21	ME21 A, U		ME21 M, N		MC26 B, E	
4. Remote mount design (small nominal diameters) Transmitter - Standard/non-Ex - Ex Zone 2/21, 22 Flowmeter sensor - Ex Zone 2/21, 22	ME22 A, U ...		MS21 A, U		ME27/28 B, E	
5. Remote mount design (small nominal diameters) Transmitter and flowmeter sensor - Standard/non-Ex - Ex Zone 2/21, 22 - Ex Zone 1/21	ME24/25 A, U ...				MS26 B, E	
6. Remote mount design (small nominal diameters) Transmitter - Standard/non-Ex - Ex Zone 2/21, 22 Flowmeter sensor - Ex Zone 1/21						

Fig. 1: FCM2000 overview

## Transport

### 3 Transport

#### 3.1 Inspection

Check the devices for possible damage that may have occurred during transport. Damages in transit must be recorded on the transport documents. All claims for damages must be claimed without delay against the shipper and before the installation.

#### 3.2 General information on transport

Observe the following when transporting the device to the measurement site:

- The center of gravity is off center.
- Flanged units may not be lifted by the converter housing or terminal box.

#### 3.3 Transporting MS2 devices of nominal size "U" (DN 6, 1/4")



##### Notice – Potential damage to parts!

Before commissioning, both transport safety screws must be removed and replaced by the nipples included with the shipment as shown in Fig. 2. Before removing the transport safety screws, take note of the following:

Under no circumstances must moisture, liquids, or foreign objects enter the flowmeter sensor housing, as this could adversely affect measurement accuracy.

The transport safety screws are installed at the factory in order to prevent damage during shipment (applies to nominal size "U" DN 6 [1/4"] only). The flowmeter sensor is a sensitive instrument and must, therefore, be handled with appropriate care.

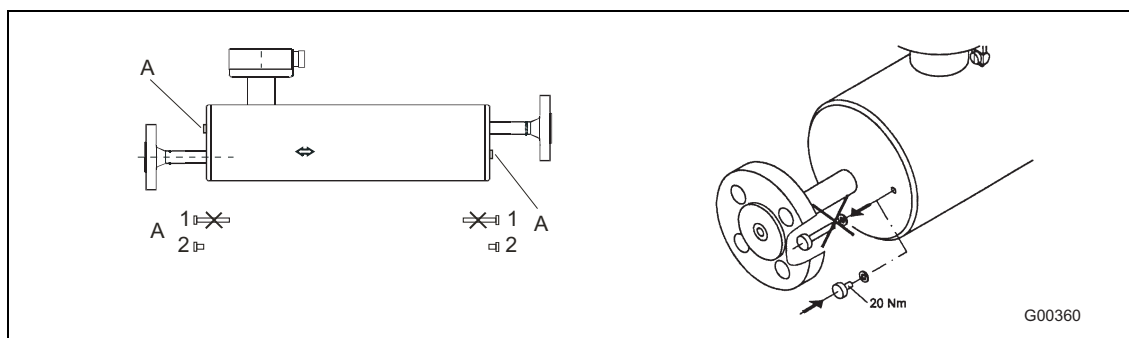

Fig. 2: Transport safety measures for nominal size DN 6 (1/4")

- 1 Transport safety screw
- 2 Nipple and gasket

**4 Installation**

**4.1 Electrical connection**

**4.1.1 Electrical connections between the transmitter and the flowmeter sensor**

**Connecting transmitter ME21 to flowmeter sensor MC21**

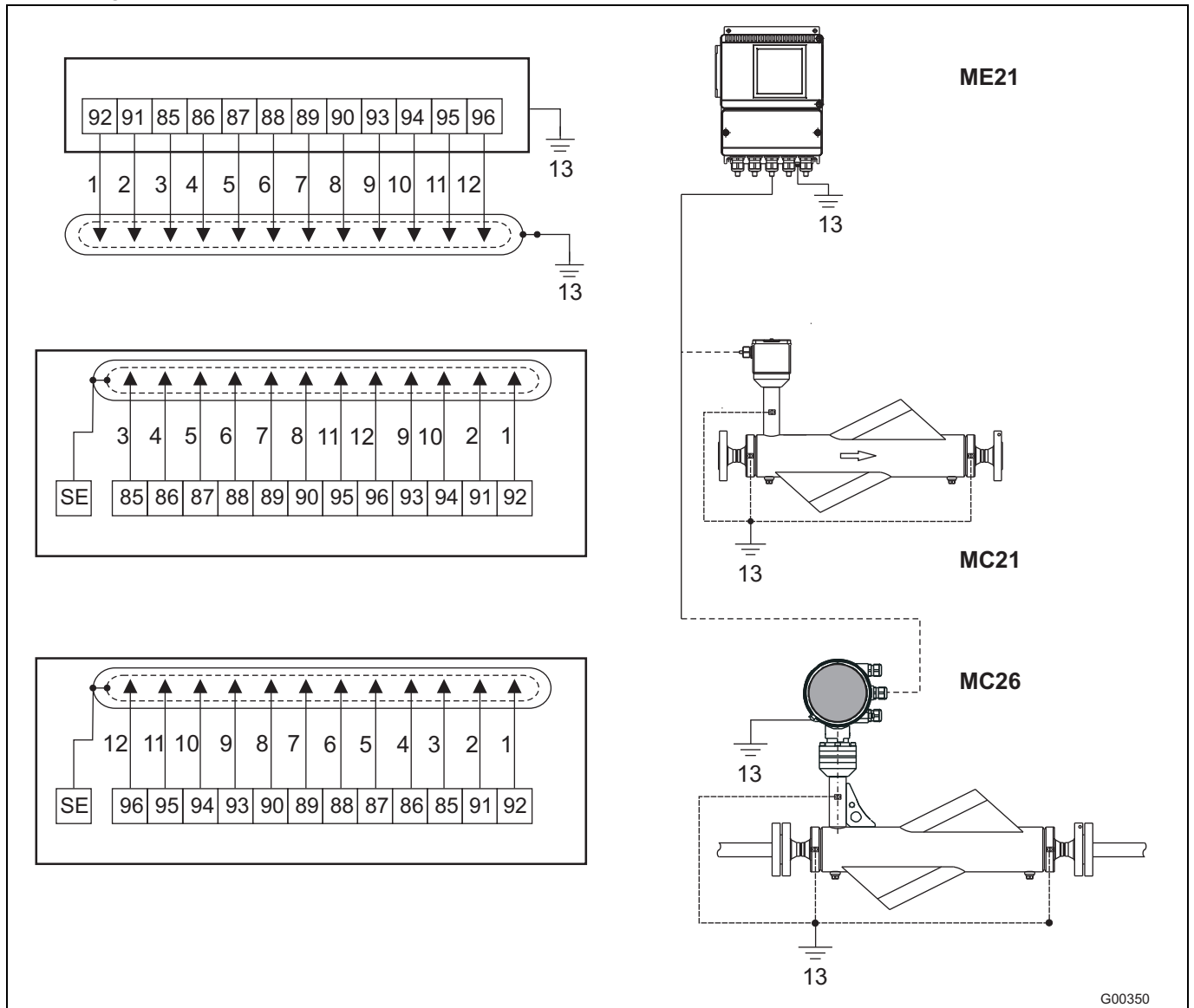
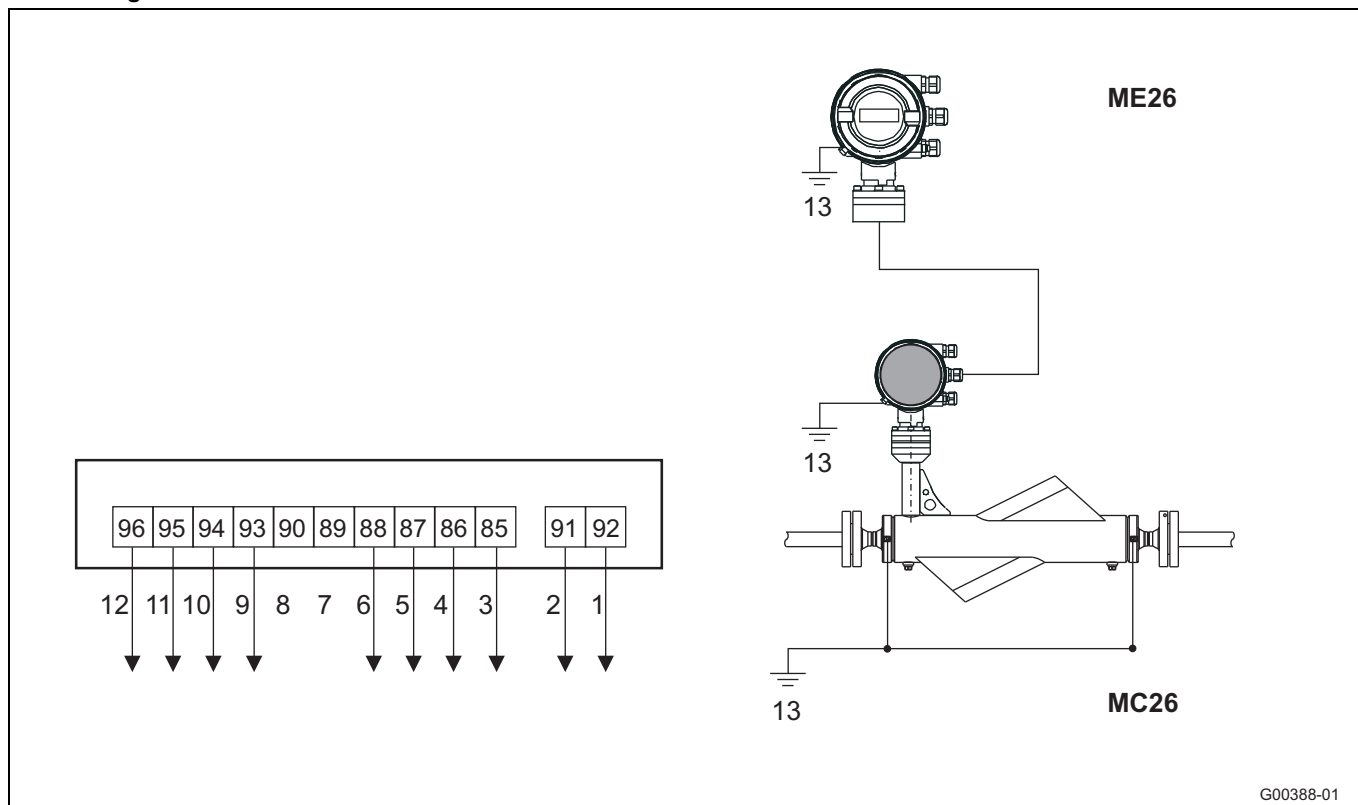

**Fig. 3**

- 91 / 92            Driver
- 93 / 94 / 95 / 96    Temperature
- 85 / 86            Sensor 1
- 87 / 88            Sensor 2

- 1    Red/blue
- 2    Gray/pink
- 3    White
- 4    Brown
- 5    Green
- 6    Yellow
- 7    Gray
- 8    Pink
- 9    Black
- 10   Violet
- 11   Blue
- 12   Red
- 13   "PA" equipotential bonding. The precise position of the ground terminals may vary according to the device type. However, the position is appropriately labeled in each case. When connecting transmitter ME21 to flowmeter sensor MC26, transmitter ME21 also has to be connected to "PA".

Connecting transmitter ME26 to flowmeter sensor MC26



G00388-01

Fig. 4

91 / 92 Driver  
 93 / 94 / 95 / 96 Temperature  
 85 / 86 Sensor 1  
 87 / 88 Sensor 2

1 Pink  
 2 Gray  
 3 White  
 4 Brown  
 5 Green  
 6 Yellow  
 7  
 8  
 9 Black  
 10 Violet  
 11 Blue  
 12 Red  
 13 "PA" equipotential bonding



**Important**

For reasons of EMC, the wires must be routed in pairs.

**Connecting transmitter ME2 to flowmeter sensor MS2**

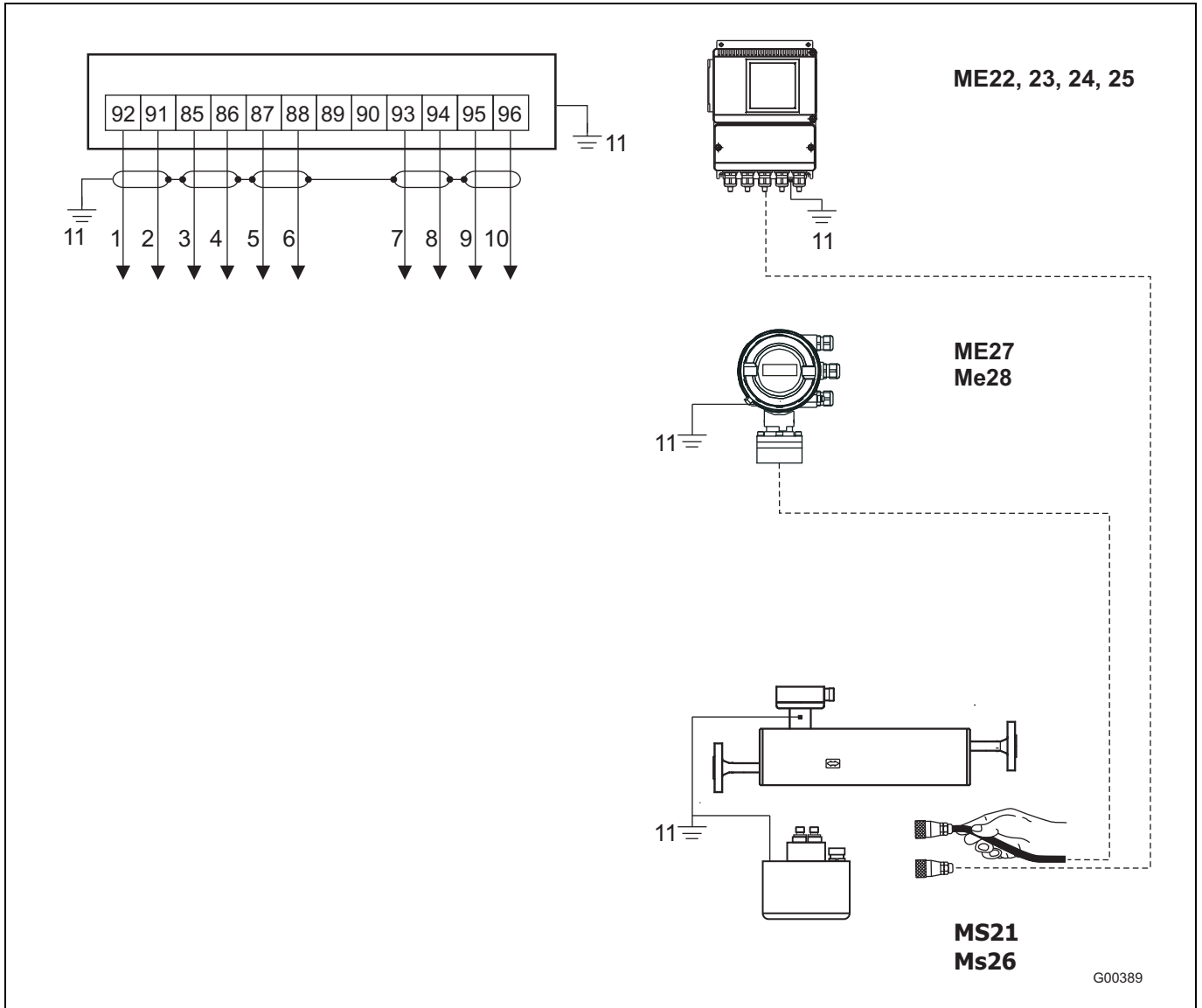

Fig. 5

- 91 / 92 Driver
- 93 / 94 / 95 / 96 Temperature
- 85 / 86 Sensor 1
- 87 / 88 Sensor 2

- 1 Red
- 2 Brown
- 3 Green
- 4 Blue
- 5 Gray
- 6 Violet
- 7 White
- 8 Black
- 9 Orange
- 10 Yellow
- 11 "PA" equipotential bonding. When connecting transmitter to flowmeter sensor MS26, transmitter also has to be connected to "PA".

G00389

## 4.1.2 Electrical connections between the transmitter and the peripherals

### Input and output signals, supply power ME2/MC2

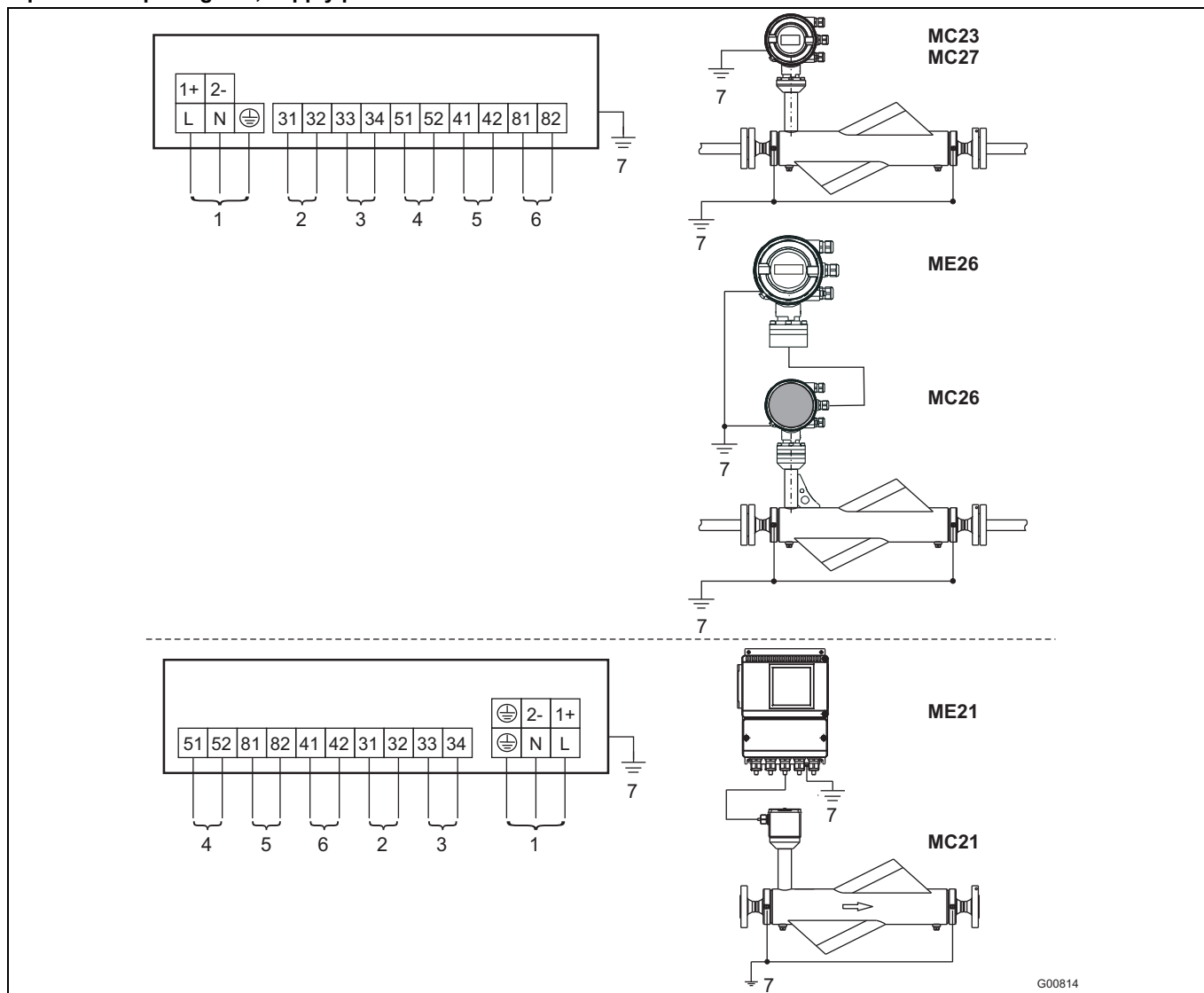

Fig. 6

- 1 Supply power  
Line voltage:  $U_{AC}$  100 ... 230 V AC, frequency 50/60 Hz, terminals L, N,  $\ominus$   
Low voltage:  $U_{AC}$  24 V, frequency 50/60 Hz, terminals 1+, 2-  
 $U_{DC}$  24 V
- 2 Current output 1: can be selected via software  
2a: function: active  
Terminals: 31, 32; 0/4 ... 20 mA ( $0 \Omega \leq R_B \leq 560 \Omega$ , MC27/ME26:  $0 \Omega \leq R_B \leq 300 \Omega$ )  
2b: alternate function: passive (option D)  
Terminals: 31, 32; 4 ... 20 mA ( $0 \Omega \leq R_B \leq 600 \Omega$ )  
Source voltage  $12 \leq U_q \leq 30$  V
- 3 Current output 2: can be selected via software  
Function: passive  
Terminals: 33, 34; 4 ... 20 mA ( $0 \Omega \leq R_B \leq 600 \Omega$ )  
Source voltage  $12 \leq U_q \leq 30$  V
- 4a Passive pulse output, terminals: 51, 52  
 $f_{max} = 5$  kHz, pulse width 0.1 ... 2,000 ms  
Setting range: 0.001 ... 1,000 pulses/unit  
"Closed":  $0 \text{ V} \leq U_{CEL} \leq 2 \text{ V}$ ,  $2 \text{ mA} \leq I_{CEL} \leq 65 \text{ mA}$   
"Open":  $16 \text{ V} \leq U_{CEH} \leq 30 \text{ V}$ ,  $0 \text{ mA} \leq I_{CEH} \leq 0.2 \text{ mA}$
- 4b Active pulse output  
 $U = 16 \dots 30 \text{ V}$ , load  $\geq 150 \Omega$ ,  $f_{max} = 5$  kHz,
- 5 Contact output, passive  
Terminals: 41, 42  
"Closed":  $0 \text{ V} \leq U_{CEL} \leq 2 \text{ V}$ ,  $2 \text{ mA} \leq I_{CEL} \leq 65 \text{ mA}$   
"Open":  $16 \text{ V} \leq U_{CEH} \leq 30 \text{ V}$ ,  $0 \text{ mA} \leq I_{CEH} \leq 0.2 \text{ mA}$
- 6 Contact input, passive  
Terminals: 81, 82  
"On":  $16 \text{ V} \leq U_{KL} \leq 30 \text{ V}$   
"Off":  $0 \text{ V} \leq U_{KL} \leq 2 \text{ V}$
- 7 Equipotential bonding "PA" (when connecting transmitter ME2 to flowmeter sensor MC26, transmitter ME2 also has to be connected to "PA").



### Important

You can find the applicable Ex-relevant connection data in the section titled "Ex relevant specifications".

Input and output signals, supply power ME2/MS2

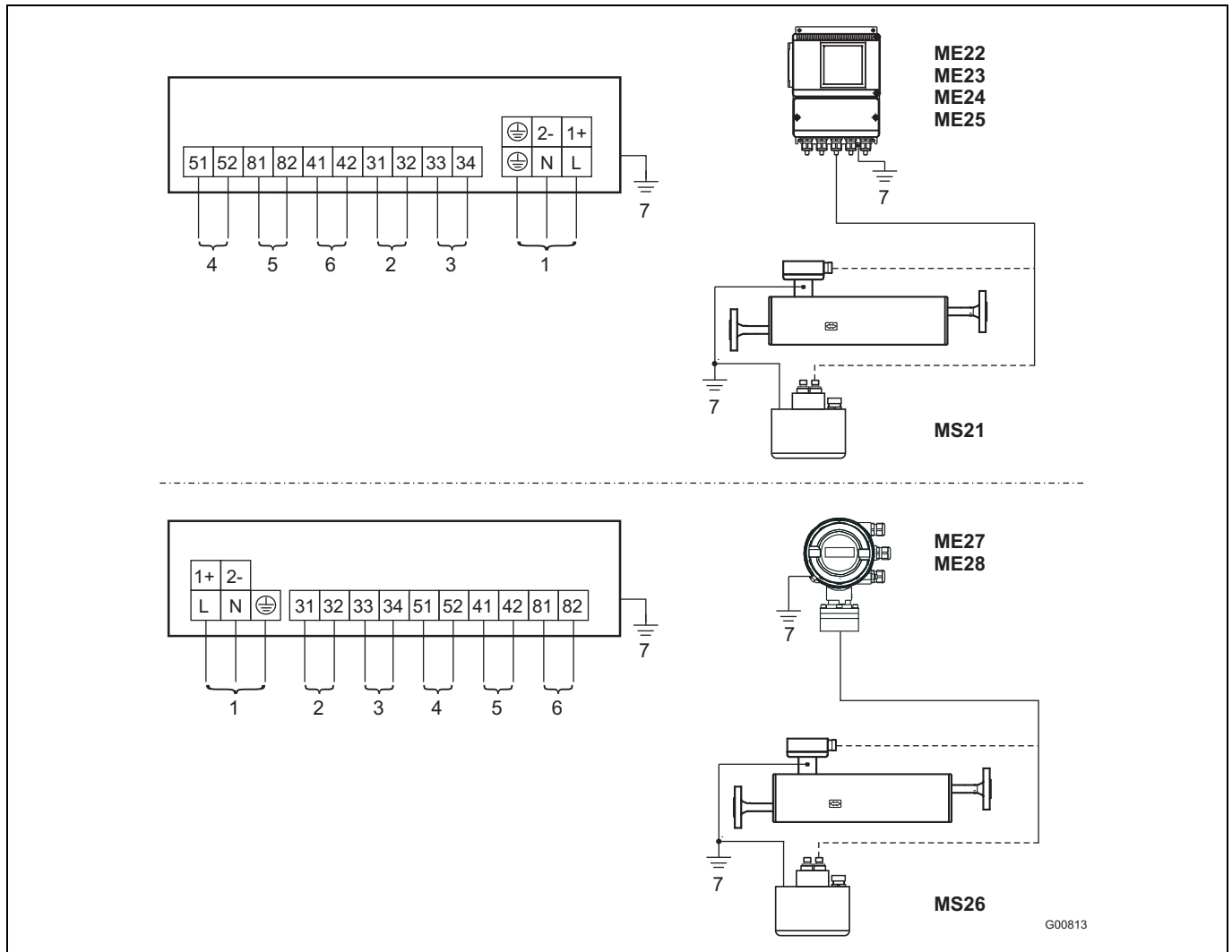

Fig. 7

- 1 Supply power  
Line voltage:  $U_{AC}$  100 ... 230 V AC, frequency 50/60 Hz, terminals L, N,  $\ominus$   
Low voltage:  $U_{AC}$  24 V, frequency 50/60 Hz, terminals 1+, 2-  
 $U_{DC}$  24 V
- 2 Current output 1: can be selected via software  
2a: function: active  
Terminals: 31, 32; 0/4 ... 20 mA ( $0 \Omega \leq R_B \leq 560 \Omega$ , ME27/28:  $0 \Omega \leq R_B \leq 300 \Omega$ )  
2b: alternate function: passive (option D)  
Terminals: 31, 32; 4 ... 20 mA ( $0 \Omega \leq R_B \leq 600 \Omega$ )  
Source voltage  $12 \leq U_q \leq 30$  V
- 3 Current output 2: can be selected via software  
Function: passive  
Terminals: 33, 34; 4 ... 20 mA ( $0 \Omega \leq R_B \leq 600 \Omega$ )  
Source voltage  $12 \leq U_q \leq 30$  V
- 4a Passive pulse output, terminals: 51, 52  
 $f_{max} = 5$  kHz, pulse width 0.1 ... 2,000 ms  
Setting range: 0.001 ... 1,000 pulses/unit  
"Closed":  $0 V \leq U_{CEL} \leq 2 V$ ,  $2 mA \leq I_{CEL} \leq 65 mA$   
"Open":  $16 V \leq U_{CEH} \leq 30 V$ ,  $0 mA \leq I_{CEH} \leq 0.2 mA$
- 4b Active pulse output  
 $U = 16 \dots 30$  V, load  $\geq 150 \Omega$ ,  $f_{max} = 5$  kHz,
- 5 Contact output, passive  
Terminals: 41, 42  
"Closed":  $0 V \leq U_{CEL} \leq 2 V$ ,  $2 mA \leq I_{CEL} \leq 65 mA$   
"Open":  $16 V \leq U_{CEH} \leq 30 V$ ,  $0 mA \leq I_{CEH} \leq 0.2 mA$
- 6 Contact input, passive  
Terminals: 81, 82  
"On":  $16 V \leq U_{KL} \leq 30 V$   
"Off":  $0 V \leq U_{KL} \leq 2 V$
- 7 "PA" equipotential bonding. When transmitter ME2 is connected to flowmeter sensor MS26, transmitter ME2 also has to be connected to "PA".

## PROFIBUS PA/FOUNDATION Fieldbus, supply power for ME2/MC2

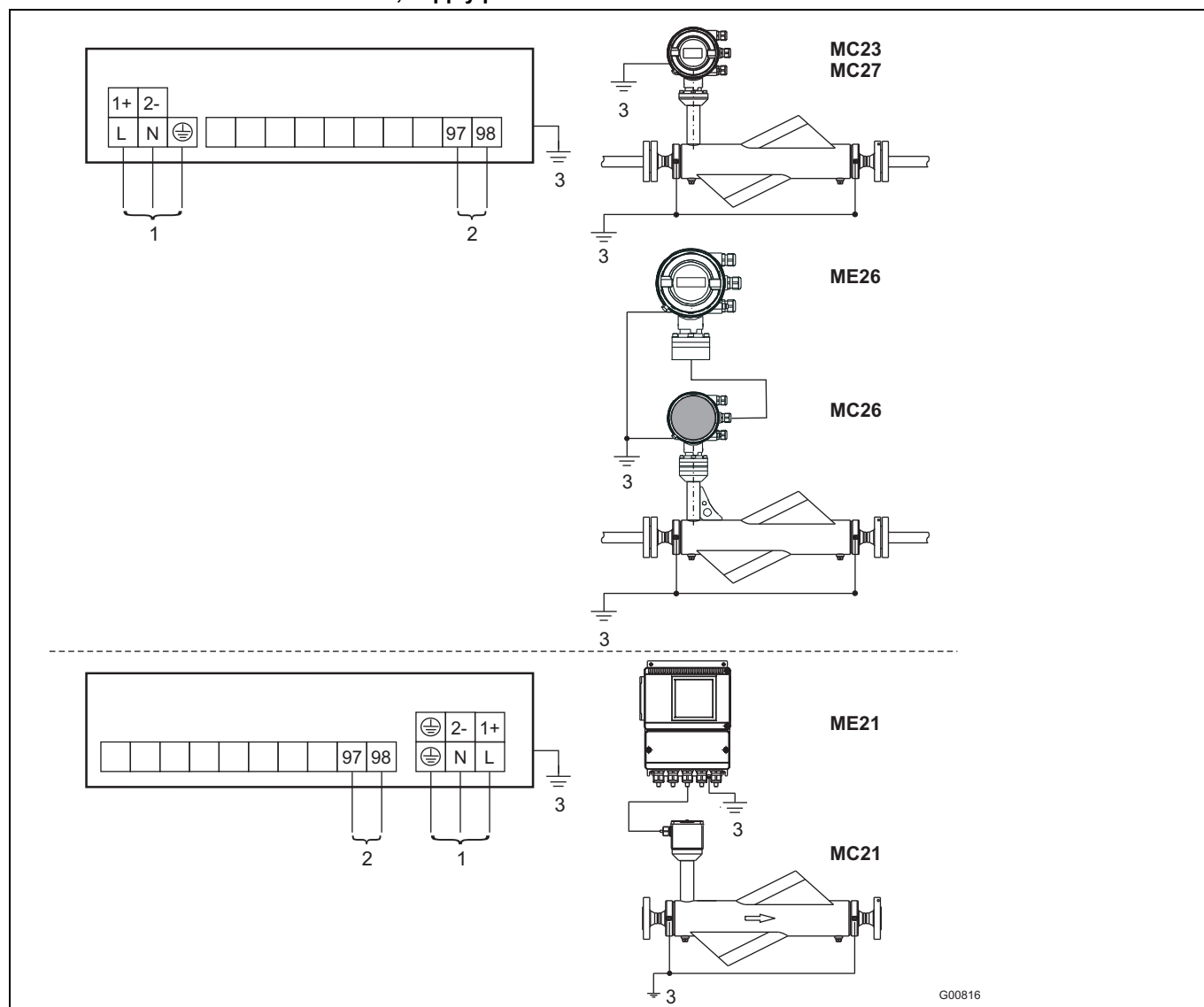
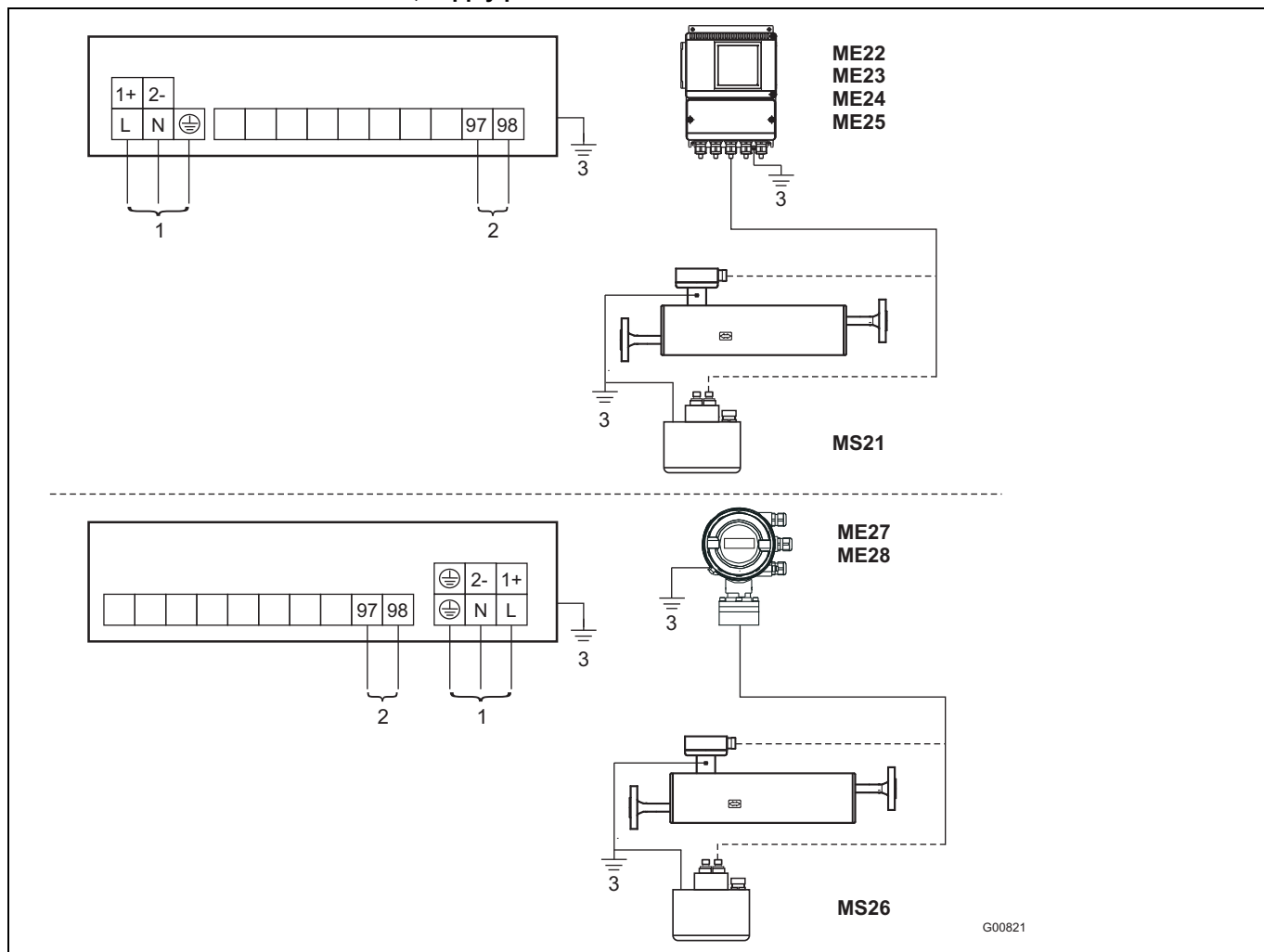

Fig. 8

- 1 Supply power  
Line voltage:  $U_{AC}$  100 ... 230 V AC, frequency 50/60 Hz, terminals L, N,  $\ominus$   
Low voltage:  $U_{AC}$  24 V, frequency 50/60 Hz, terminals 1+, 2-;  
 $U_{DC}$  24 V
- 2a PROFIBUS PA design according to IEC 61158-2 (Profile 3.0)  
 $U = 9 \dots 32$  V  
 $I = 14$  mA (normal operation)  
 $I = 26$  mA (in the event of an error/FDE)  
Terminals: 97/98  
You can find a connection example in the operating instructions under "Connecting via M12 plug".
- 2b FOUNDATION Fieldbus design according to IEC 61158-2  
 $U = 9 \dots 32$  V  
 $I = 14$  mA (normal operation)  
 $I = 26$  mA (in the event of an error/FDE)  
Terminals: 97/98  
You can find a connection example in the operating instructions under "Connecting via M12 plug".
- 3 "PA" equipotential bonding. The precise position of the ground terminals may vary according to the device type. However, the position is appropriately labeled in each case. When connecting transmitter ME2 to flowmeter sensor MC26, transmitter ME2 also has to be connected to "PA".

**PROFIBUS PA/FOUNDATION Fieldbus, supply power for ME2/MS2**



**Fig. 9:**

- 1 Supply power  
Line voltage:  $U_{AC}$  100 ... 230 V AC, frequency 50/60 Hz, terminals L, N, ⊕  
Low voltage:  $U_{AC}$  24 V, frequency 50/60 Hz, terminals 1+, 2-;  
 $U_{DC}$  24 V
- 2a PROFIBUS PA design according to IEC 61158-2 (Profile 3.0)  
 $U = 9 \dots 32$  V  
 $I = 14$  mA (normal operation)  
 $I = 26$  mA (in the event of an error/FDE)  
Terminals: 97/98  
You can find a connection example in the operating instructions under "Connecting via M12 plug".
- 2b FOUNDATION Fieldbus design according to IEC 61158-2  
 $U = 9 \dots 32$  V  
 $I = 14$  mA (normal operation)  
 $I = 26$  mA (in the event of an error/FDE)  
Terminals: 97/98  
You can find a connection example in the operating instructions under "Connecting via M12 plug".
- 3 The precise position of the ground terminals may vary according to the device type. However, the position is appropriately labeled in each case. When transmitter ME2 is connected to flowmeter sensor MS26, transmitter ME2 also has to be connected to "PA".



**Important**

An additional document with Ex safety instructions is available for measuring systems that are used in explosion hazardous areas (Applies to FM / CSA only).  
As a result, it is crucial that the specifications and data it lists are also observed.

## 4.2 Ex relevant specifications



### Important

An additional document with Ex safety instructions is available for measuring systems that are used in explosion hazardous areas (Applies to FM / CSA only).

As a result, it is crucial that the specifications and data it lists are also observed.

### Overview of the different output options

	ATEX/IECEX Zone 2	ATEX/IECEX Zone 1
<b>I</b> Output option A/B in the order number	<ul style="list-style-type: none"> <li>- Current output 1: active</li> <li>- Current output 2: passive</li> <li>- Pulse output: active/passive, switchable</li> <li>- Contact input and output: passive</li> </ul>	<ul style="list-style-type: none"> <li>- Current output 1: active</li> <li>- Current output 2: passive</li> <li>- Pulse output: active/passive, switchable</li> <li>- Contact input and output: passive</li> </ul>
<b>II</b> Output option D in the order number		<ul style="list-style-type: none"> <li>- Current output 1: passive</li> <li>- Current output 2: passive</li> <li>- Pulse output: active/passive, switchable</li> <li>- Contact input and output: passive</li> </ul>
<b>III</b> Output option X and communication option 3, 5, or 7 in the order number	<ul style="list-style-type: none"> <li>- Fieldbus communication (PROFIBUS PA/FOUNDATION Fieldbus)</li> </ul>	<ul style="list-style-type: none"> <li>- Fieldbus communication (PROFIBUS PA/FOUNDATION Fieldbus)</li> </ul>

### Version I: Active/Passive current outputs

Types: ME21/ME22/ME23/ME24/ME25 and MC23				
	Protection type "nA" (Zone 2)		General operating values	
	U (V)	I (mA)	U <sub>b</sub> (V)	I <sub>b</sub> (mA)
Current output 1 Active Terminals 31/32	30	30	30	30
Current output 2 Passive Terminals 33/34	30	30	30	30
Pulse output Active or passive Terminals 51/52	30	65	30	65
Contact output Passive Terminals 41/42	30	65	30	65
Contact input Passive Terminals 81/82	30	10	30	10

All inputs and outputs are electrically isolated from each other and from the supply power.

Types: ME26/ME27/ME28 and MC27												
	Protection type "nA" (Zone 2)		General operating values		Protection type "e" (Zone 1)		Protection type "ib" (Zone 1)					
	U <sub>i</sub> (V)	I <sub>i</sub> (mA)	U <sub>b</sub> (V)	I <sub>b</sub> (mA)	U (V)	I (A)	U <sub>o</sub> (V)	I <sub>o</sub> (mA)	P <sub>o</sub> (mW)	C <sub>o</sub> (nF)	C <sub>o pa</sub> (nF)	L <sub>o</sub> (mH)
Current output 1 Active Terminals 31/32 Terminal 32 is connected to "PA"	30	30	30	30	60	35	20	100	500	217	0	3.8
							U <sub>i</sub> (V)	I <sub>i</sub> (mA)	P <sub>i</sub> (mW)	C <sub>i</sub> (nF)	C <sub>i pa</sub> (nF)	L <sub>i</sub> (mH)
							60	100	500	2.4	2.4	0.17
Current output 2 Passive Terminals 33/34 Terminal 34 is connected to "PA"	30	30	30	30	60	35	30	100	760	2.4	2.4	0.17
Pulse output Passive Terminals 51/52	30	65	30	65	60	35	15	30	115	2.4	2.4	0.17
Contact output Passive Terminals 41/42	30	65	30	65	60	35	15	30	115	2.4	2.4	0.17
Contact input Passive Terminals 81/82	30	10	30	10	60	35	30	60	500	2.4	2.4	0.17

All inputs and outputs are electrically isolated from each other and from the supply power. Only current outputs 1 and 2 are not electrically isolated from one another.

### Version II: Passive/Passive current outputs

Types: ME26/ME27/ME28 and MC27												
	Protection type "nA" (Zone 2)		General operating values		Protection type "e" (Zone 1)		Protection type "ia" (Zone 1)					
	U <sub>i</sub> (V)	I <sub>i</sub> (mA)	U <sub>b</sub> (V)	I <sub>b</sub> (mA)	U (V)	I (A)	U <sub>i</sub> (V)	I <sub>i</sub> (mA)	P <sub>i</sub> (mW)	C <sub>i</sub> (nF)	C <sub>i pa</sub> (nF)	L <sub>i</sub> (mH)
Current output 1 Passive Terminals 31/32	30	30	30	30	60	35	60	300	2000	0,47	0,47	0,17
Current output 2 Passive Terminals 33/34	30	30	30	30	60	35	60	300	2000	0,47	0,47	0,17
Pulse output Passive Terminals 51/52	30	65	30	65	60	35	60	300	2000	0,47	0,47	0,17
Contact output Passive Terminals 41/42	30	65	30	65	60	35	60	300	2000	0,47	0,47	0,17
Contact input Passive Terminals 81/82	30	10	30	10	60	35	60	300	2000	0,47	0,47	0,17

All inputs and outputs are electrically isolated from each other and from the supply power.

Version III: Fieldbus communication

Types ME21/ME22/ME23/ME24/ME25/ME26/ME27/ME28 and MC23/MC27										
	Protection type "nL" (Zone 2)		General operating values		Protection type "n" FNICO (Zone 2)					
	U (V)	I (mA)	U <sub>b</sub> (V)	I <sub>b</sub> (mA)	U <sub>i</sub> (V)	I <sub>i</sub> (mA)	P <sub>i</sub> (mW)	C <sub>i</sub> (nF)	C <sub>i pa</sub> (nF)	L <sub>i</sub> (mH)
Fieldbus Passive Terminals 97/98	60	500	32	10	60	500	7,000	0	0	0.17

The output and supply power are electrically isolated.

Types ME26/ME27/ME28 and MC27																
	Type of protection "e" (Zone 1)		General operating values		Protection type "ia" FISCO (Zone 1)						Protection type "ia" (Zone 1)					
	U (V)	I (A)	U <sub>b</sub> (V)	I <sub>b</sub> (mA)	U <sub>i</sub> (V)	I <sub>i</sub> (mA)	P <sub>i</sub> (mW)	C <sub>i</sub> (nF)	C <sub>i pa</sub> (nF)	L <sub>i</sub> (mH)	U <sub>i</sub> (V)	I <sub>i</sub> (mA)	P <sub>i</sub> (mW)	C <sub>i</sub> (nF)	C <sub>i pa</sub> (nF)	L <sub>i</sub> (mH)
Fieldbus Passive Terminals 97/98	60	35	32	10	60	380	5320	0	0	0.17	60	380	5320	0	0	0.17

The output and supply power are electrically isolated.

**Special conditions**

The output circuits are designed in such a way that they can be connected to both intrinsically-safe and non-intrinsically-safe circuits. It is not permitted to combine intrinsically safe and non-intrinsically safe circuits. On intrinsically safe circuits, equipotential bonding must be in place along the entire length of the cable used for the current outputs. The rated voltage of the non-intrinsically safe circuits is U<sub>M</sub> = 60 V.

The contact output and the pulse output (terminals 41 / 42 and 51 / 52) can be wired internally as a NAMUR contact for the purpose of connecting a NAMUR amplifier.

The cable glands are supplied in black by default. If the signal outputs are wired to intrinsically safe circuits, we recommend that you use the light blue caps supplied for the appropriate cable entries.



**Important**

If the protective conductor (PE) is connected in the flowmeter's terminal box, you must ensure that no dangerous potential difference can arise between the protective conductor (PE) and the equipotential bonding (PA) in the potentially explosive area.

### 4.2.1 ATEX/IECEX Ex approval

EC type-examination certificate in accordance with ATEX and IECEx

KEMA ATEX 08ATEX0150 X, KEMA 08 ATEX 0151X, or IECEx KEM 08.0034X

#### 4.2.1.1 Flowmeter sensor MC2 in accordance with ATEX and IECEx

Model	MC26 and MC27 Zone 1		
	Ambient temperature	<=40 °C (104 °F)	<=50 °C (122 °F)
<b>Temperature class</b>			
T1	200 °C (392 °F)	200 °C (392 °F)	200 °C (392 °F)
T2	200 °C (392 °F)	200 °C (392 °F)	200 °C (392 °F)
T3	185 °C (365 °F)	180 °C (356 °F)	180 °C (356 °F)
T4	125 °C (257 °F)	120 °C (248 °F)	120 °C (248 °F)
T5	85 °C (185 °F)	85 °C (185 °F)	75 °C (167 °F)
T6	65 °C (149 °F)	65 °C (149 °F)	60 °C (140 °F)

Model	MC21 and MC23 Zone 2		
	Ambient temperature	<=40 °C (104 °F)	<=50 °C (122 °F)
<b>Temperature class</b>			
T1	200 °C (392 °F)	200 °C (392 °F)	180 °C (356 °F)
T2	200 °C (392 °F)	200 °C (392 °F)	180 °C (356 °F)
T3	180 °C (356 °F)	180 °C (356 °F)	180 °C (356 °F)
T4	115 °C (239 °F)	115 °C (239 °F)	115 °C (239 °F)
T5	80 °C (176 °F)	80 °C (176 °F)	75 °C (167 °F)
T6	60 °C (140 °F)	60 °C (140 °F)	60 °C (140 °F)

Ambient and process conditions:

T<sub>amb</sub> -20 ... 60 °C (-4 ... 140 °F)

T<sub>amb, optional</sub> -40 ... 60 °C (-40 ... 104 °F) (only for devices with a compact design)

T<sub>medium</sub> -50 ... 200 °C (-58 ... 392 °F)

Protection class IP 65, IP 67, and NEMA 4X/type 4X

Specific coding in accordance with ATEX and IECEx applies depending on the design of the flowmeter sensor (compact or separate); see the overview on page 7).

#### Design MC21

Zone 2	Designation	
ATEX	II 3 G Ex nA II T6 ... T2 II 2 D Ex tD A21 IP6X T115 °C ... T <sub>medium</sub>	
IECEX	Ex nA II T6 ... T2 Ex tD A21 IP6X T115 °C ... T <sub>medium</sub>	

#### Design MC23

Zone 2	Designation	
ATEX	II 3 G Ex nA nR II T6 ... T2 II 3 G Ex nA nR [nL] IIC T6 ... T2 II 2 D Ex tD A21 IP6X T115 °C ... T <sub>medium</sub> FNICO field device	No fieldbus, no M12 plug FNICO fieldbus, no M12 plug FNICO fieldbus, no M12 plug
IECEX	Ex nA nR II T6 ... T2 Ex nA nR [nL] IIC T6 ... T2 Ex tD A21 IP6X T115 °C ... T <sub>medium</sub> FNICO field device	No fieldbus, no M12 plug FNICO fieldbus, no M12 plug No M12 plug FNICO fieldbus

**Design MC26**

Zone 1	Designation	
ATEX	II 2 G Ex e mb [ia] IIC T6 ... T2	≤ DN 40 (1 1/2")
	II 1/2 G Ex e mb [ia] IIC T6 ... T2 II 2 D Ex tD A21 IP6X T115 °C ... T <sub>medium</sub>	≥ DN 50 (2")
IECEX	Ex e mb [ia] IIC T6 ... T2 Ex tD A21 IP6X T115 °C ... T <sub>medium</sub>	

**Design MC27**

Zone 1	Designation	
<b>ATEX</b>		
Version II/III	II 2 G Ex d e [ia] [ib] IIC T6 ... T2	≤ DN 40 (1 1/2") 2 passive analog outputs, outputs "ia"/"e", depending on user wiring, or FISCO fieldbus
Version I	II 2 G Ex d e [ib] IIC T6 ... T2	≤ DN 40 (1 1/2") Active/passive analog outputs, outputs "ib"/"e", depending on user wiring
Version II/III	II 1/2 G Ex d e [ia] [ib] IIC T6 ... T2	≥ DN 50 (2") 2 passive analog outputs, outputs "ia"/"e", depending on user wiring, or FISCO fieldbus
Version I	II 1/2 G Ex d e [ib] IIC T6 ... T2	≥ DN 50 (2") Active/passive analog outputs, outputs "ib"/"e", depending on user wiring
Version I/II/III	II 2 D Ex tD A21 IP6X T115 °C ... T <sub>medium</sub>	Outputs "e"
Version II/III	II 2 D Ex tD [iaD] A21 IP6X T115 °C ... T <sub>medium</sub>	2 passive analog outputs, outputs "ia"/"e", depending on user wiring, or FISCO fieldbus
Version I	II 2 D Ex tD [ibD] A21 IP6X T115 °C ... T <sub>medium</sub>	Active/passive analog outputs, outputs "ib"/"e", depending on user wiring
Version III	FISCO field device	FISCO fieldbus
<b>IECEX</b>		
Version II/III	Ex d e [ia] [ib] IIC T6 ... T2	2 passive analog outputs, outputs "ia"/"e", depending on user wiring, or FISCO fieldbus
Version I	Ex d e [ib] IIC T6 ... T2	Active/passive analog outputs, outputs "ib"/"e", depending on user wiring
Version I/II/III	Ex tD A21 IP6X T115 °C ... T <sub>medium</sub>	Outputs "e"
Version II/III	Ex tD [iaD] A21 IP6X T115 °C ... T <sub>medium</sub>	2 passive analog outputs, outputs "ia"/"e", depending on user wiring, or FISCO fieldbus
Version I	Ex tD [ibD] A21 IP6X T115 °C ... T <sub>medium</sub>	Active/passive analog outputs, outputs "ib"/"e", depending on user wiring
Version III	FISCO field device	FISCO fieldbus

**4.2.1.2 Flowmeter sensor MS2 in accordance with ATEX**

<b>Model</b>	<b>MS2 Zone 1</b>
<b>Ambient temperature</b>	-20 ... 50 °C (-4 ... 122 °F)
<b>Temperature class</b>	
T1	180 °C (356 °F)
T2	180 °C (356 °F)
T3	180 °C (356 °F)
T4	125 °C (257 °F)
T5	80 °C (176 °F)
T6	-

Ambient and process conditions:

T<sub>amb</sub> -20 ... 50 °C (-4 ... 122 °F)  
 T<sub>medium</sub> -50 ... 180 °C (-58 ... 356 °F)  
 Protection class IP 65, IP 67, and NEMA 4X/type 4X

Specific coding applies for ATEX and IECEx, depending on the design of the flowmeter sensor (compact or separate); see the overview on page 7).

**Design MS26**

<b>Zone 1</b>	<b>Designation</b>
ATEX	II 2 G Ex ib IIC T5 ... T3

**4.2.1.3 Transmitter ME2, separate design, in accordance with ATEX and IECEx**

Ambient and process conditions:

T<sub>amb</sub> -20 ... 60 °C (-4 ... 140 °F)  
 Protection class IP 65, IP 67, and NEMA 4X/type 4X

Specific coding applies for ATEX and IECEx, depending on the design of the flowmeter sensor (compact or separate); see the overview on page 7).

**Design ME21 / ME24 / ME25 M, N**

	<b>Designation</b>	
ATEX	II 3 G Ex nR II T6 II 3 G Ex nR [nL] IIC T6 II 2 D Ex tD A21 IP6X T115 °C FNICO field device	No fieldbus, no M12 plug FNICO fieldbus, no M12 plug No M12 plug FNICO fieldbus
IECEx	Ex nR II T6 Ex nR [nL] IIC T6 Ex tD A21 IP6X T115 °C FNICO field device	No fieldbus, no M12 plug FNICO fieldbus, no M12 plug No M12 plug FNICO fieldbus

**Design ME26 for flowmeter sensor MC2**

Zone 1	Designation	
<b>ATEX</b>		
Version II/III	II 2 G Ex d e [ia] [ib] IIC T6	2 passive analog outputs, outputs "ia"/"e", depending on user wiring, or FISCO fieldbus
Version I	II 2 G Ex d e [ib] IIC T6	Active/passive analog outputs, outputs "ib"/"e", depending on user wiring
Version I/II/III	II 2 D Ex tD A21 IP6X T115 °C	Outputs "e"
Version II/III	II 2 D Ex tD [iaD] A21 IP6X T115 °C	2 passive analog outputs, outputs "ia"/"e", depending on user wiring, or FISCO fieldbus
Version I	II 2 D Ex tD [ibD] A21 IP6X T115 °C	Active/passive analog outputs, outputs "ib"/"e", depending on user wiring
Version III	FISCO field device	FISCO fieldbus
<b>IECEX</b>		
Version II/III	Ex d e [ia] [ib] IIC T6	2 passive analog outputs, outputs "ia"/"e", depending on user wiring, or FISCO fieldbus
Version I	Ex d e [ib] IIC T6	Active/passive analog outputs, outputs "ib"/"e", depending on user wiring
Version I/II/III	Ex tD A21 IP6X T115 °C	Outputs "e"
Version II/III	Ex tD [iaD] A21 IP6X T115 °C	2 passive analog outputs, outputs "ia"/"e", depending on user wiring, or FISCO fieldbus
Version I	Ex tD [ibD] A21 IP6X T115 °C	Active/passive analog outputs, outputs "ib"/"e", depending on user wiring
Version III	FISCO field device	FISCO fieldbus

**Design ME27/ME28 for flowmeter sensor MS2**

Zone 1	Designation	
<b>ATEX</b>		
Version II/III	II 2 G Ex d e [ia] [ib] IIC T6	2 passive analog outputs, outputs "ia"/"e", depending on user wiring, or FISCO fieldbus
Version I	II 2 G Ex d e [ib] IIC T6	Active/passive analog outputs, outputs "ib"/"e", depending on user wiring
Version II/III	II 2 D Ex tD [iaD] A21 IP6X T115 °C	2 passive analog outputs, outputs "ia"/"e", depending on user wiring, or FISCO fieldbus
Version I	II 2 D Ex tD [ibD] A21 IP6X T115 °C	Active/passive analog outputs, outputs "ib"/"e", depending on user wiring
	FISCO field device	FISCO fieldbus



**Important**

When using the device in explosion hazardous areas, the additional temperature specifications in the section titled "Ex relevant specifications" on the data sheet or in the the separate Ex safety instructions (SM/FCM2000/FM/CSA) must be observed.

## 5 Commissioning



### Important

An additional document with Ex safety instructions is available for measuring systems that are used in explosion hazardous areas (Applies to FM / CSA only).  
As a result, it is crucial that the specifications and data it lists are also observed.

### 5.1 General information

#### Inspection prior to switching on supply power

The following points must be checked before commissioning the device:

- The assignment of the flowmeter sensor to the transmitter must be correct.
- The wiring must be correct according to the electrical connections.
- The flowmeter sensor must be correctly grounded.
- The external data memory module (FRAM) must have the same serial number as the flowmeter sensor.
- The external data memory module (FRAM) must be inserted at the correct location (see the section titled "Transmitter replacement" in the operating instructions).
- The ambient conditions must meet the specifications.
- The supply power must match the information on the name plate.

#### Inspection after switching on supply power

The following points must be checked after commissioning the device:

- The parameter configuration must correspond to the operating conditions.
- The system zero adjustment must have been made.

#### General information

- If the flow direction indicated on the display is incorrect, it could mean that the signal lead connections have been accidentally reversed.
- The locations and the sizes of the fuses can be found in the section titled "Replaceable parts list" in the operating instructions.

## 5.2 Information for safe operation – ATEX, IECEx

### 5.2.1 Inspection

Before installing the flowmeter sensor, check whether it has been damaged due to improper transport. All claims for damages must be submitted to the shipper without delay and before installation. You must comply with the installation conditions. Flowmeter sensors must be commissioned and operated according to ElexV (German ordinance on electrical installations in potentially explosive atmospheres), EN 60079-14 (setting up electrical installations in potentially explosive atmospheres), and relevant national standards. In potentially explosive atmospheres, installation, commissioning, maintenance, and servicing must only be performed by properly trained personnel. The commissioning activities described here are performed after the flowmeter has been installed and the electrical connection has been made. The supply power is switched off. When operating the flowmeter in areas containing combustible dusts, comply with EN 61241-0:2006.



#### **Warning - General risks!**

Comply with the following instructions when opening the housing:

- Make sure there is no explosion hazard.
- A fire permit is required.
- Power to all connecting cables must be switched off.
- When the housing is open, EMC protection is suspended.
- The surface temperature of the flowmeter sensor may exceed 70 °C (158 °F), depending on the fluid temperature.

### 5.2.2 Output Circuits

#### **Installation of Intrinsically Safe "i" or Increased Safety "e"**

The output circuits are designed to be connected to either intrinsically safe or non-intrinsically safe circuits. A combination of intrinsically safe and non-intrinsically circuits is not permissible. For intrinsically safe output current circuits Potential Equalization must be maintained along the entire circuit. The test voltage for the non-intrinsically safe circuits is  $U_m = 60 \text{ V}$ . When shipped the black cable connectors are installed. If the signal outputs are to be connected to intrinsically safe circuits, it is recommended that the included light blue caps be used for the corresponding cable connectors.

**5.2.3 NAMUR Contact**

The switching output and the pulse output (terminals 41, 42 / 51, 52) can be wired internally as a NAMUR contact for the purpose of connecting to a NAMUR amplifier; this is achieved by setting the jumpers accordingly. The standard wiring shown below is the factory default. The switchover is performed via jumpers (Fig. 10). See also the section titled "Electrical connections".

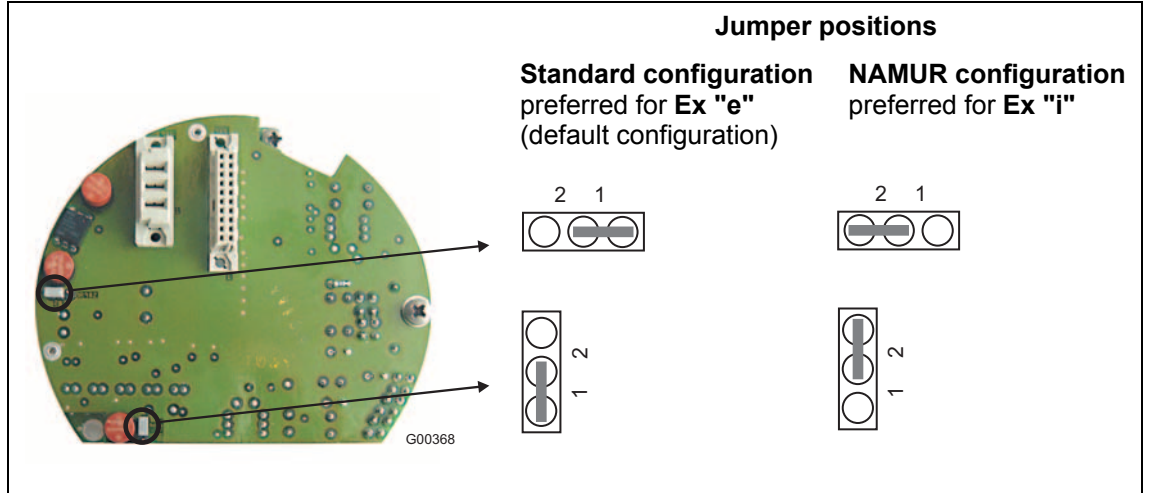

Fig. 10: Positions of jumpers

**The safety specifications for intrinsically safe circuits can be found on the EC type-examination certificate.**

- Make sure that the cover over the voltage supply connection is tightly closed. With intrinsically safe output circuits, the terminal box can be opened.
- It is recommended that you use the cable glands supplied (not for the -40 °C [-40 °F] version) for the output circuits as appropriate for the relevant type of protection:
  - Intrinsically safe: Blue
  - Non-intrinsically safe: Black
- The sensor and the transmitter housing must be connected via the equipotential bonding. For intrinsically safe current outputs, equipotential bonding needs to be in place all the way along the circuits.
- If the sensor is insulated, the maximum insulation thickness is 100 mm (4"). The transmitter housing must not be insulated.
- After switching off the flowmeter, wait  $t > 2$  minutes before opening the transmitter housing.
- When commissioning the flowmeter, refer to EN 61241-1:2004 regarding use in areas containing combustible dust.
- The operator must ensure that, when connecting the protective conductor (PE), no potential differences exist between the protective conductor and the equipotential bonding (PA), even in the event of a fault.

**Special information for use in Category 1:**

- The inside of the meter tube or nominal sizes  $\geq$  DN 50 (2") may correspond to Category 1 (Zone 0). The corrosion resistance of the materials must be taken into account.

**5.2.4 Isolation: MC26.., MC27..**

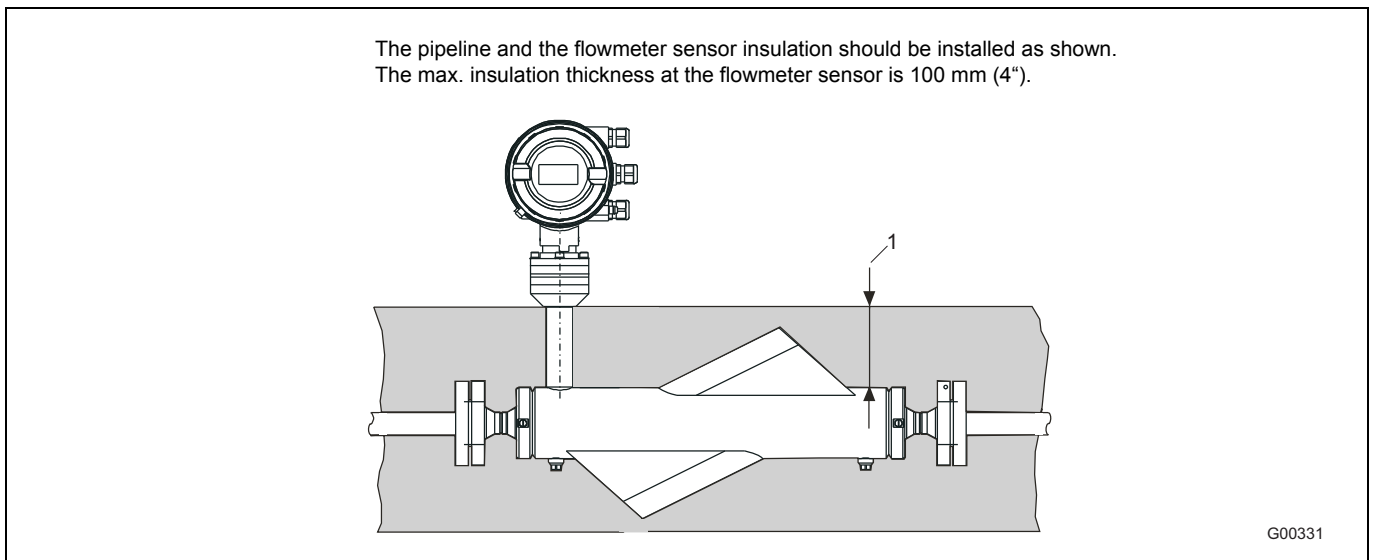

Fig. 11

1 max. 100 mm (4")

**5.2.5 Information on changing the installation**

Models MC27, ME26, ME27, and ME28 can be operated in various applications:

- When connected to an intrinsically safe circuit in Zone 1, as an intrinsically safe device (Ex ia)
- When connected to a non-intrinsically safe circuit in Zone 1, as an explosion-proof device (Ex d)
- When connected to a non-intrinsically safe circuit in Zone 2, as a "non-sparking" device (Ex nA)

If a device which is already installed is to be used in a different application, i.e., its use is to be changed, the following measures must be taken/checks must be made in accordance with the applicable standards.

**Models ME26/ME27/ME28 and MC27**

1st application	2nd application	Measures
Zone 1: Ex d, non-intrinsically safe circuits	Zone 1: Intrinsically safe circuits	<ul style="list-style-type: none"> <li>• 500 V<sub>AC</sub>/1 min or 500 x 1.414 = 710 V<sub>DC</sub>/1 min test between terminals 31 / 32, 33 / 34, 41 / 42, 51 / 52, 81 / 82, and / or 97 / 98 and terminals 31, 32, 33, 34, 41, 42, 51, 52, 81, 82, 97, 98, and the housing</li> <li>• Visual inspection, particularly of the electronic circuit boards</li> <li>• Visual inspection: no damage or explosion can be detected</li> </ul>
	Zone 2: Non-sparking (nA)	<ul style="list-style-type: none"> <li>• 500 V<sub>AC</sub>/1min or 500 x 1.414 = 710 V<sub>DC</sub>/1min test between terminals 31/32, 33/34, 41 / 42, 51 / 52, 81 / 82, and/or 97 / 98 and terminals 31, 32, 33, 34, 41, 42, 51, 52, 81, 82, 97, 98, and the housing</li> <li>• Visual inspection, particularly of the electronic circuit boards</li> <li>• Visual inspection: no damage or explosion can be detected</li> </ul>
Zone 1: Intrinsically safe circuits	Zone 1: Ex d, non-intrinsically safe circuits	<ul style="list-style-type: none"> <li>• Visual inspection: no damage to the threads (cover, 1/2" NPT cable glands)</li> </ul>
	Zone 2: Non-sparking (nA)	<ul style="list-style-type: none"> <li>• No special measures</li> </ul>
Zone 2: Non-sparking (nA)	Zone 1: Intrinsically safe circuits	<ul style="list-style-type: none"> <li>• 500 V<sub>AC</sub>/1 min or 500 x 1.414 = 710 V<sub>DC</sub>/1 min test between terminals 31 / 32, 33 / 34, 41 / 42, 51 / 52, 81 / 82, and / or 97 / 98 and terminals 31, 32, 33, 34, 41, 42, 51, 52, 81, 82, 97, 98, and the housing</li> <li>• Visual inspection, particularly of the electronic circuit boards</li> <li>• Visual inspection: no damage or explosion can be detected</li> </ul>
	Zone 1: Ex d, non-intrinsically safe circuits	<ul style="list-style-type: none"> <li>• Visual inspection: no damage to the threads (cover, 1/2" NPT cable glands)</li> </ul>

**Cables and cable entries**

The devices are supplied either with cable glands or with 1/2" NPT threads; you specify which you require in the order number. The cable glands supplied are ATEX-/IECEx-certified. In order to achieve the required tightness, the outer cable diameter must be between 5 mm (0.2") and 9 mm (0.35").

**Warning – Risk to persons!**

Devices certified in accordance with CSA are only ever supplied with 1/2" NPT threads without glands.

However, it is also possible to supply devices certified in accordance with ATEX or IECEx with 1/2" NPT threads without glands. In such cases, the user is responsible for ensuring that the cable piping/glands are installed in accordance with the relevant national standards (e.g., NEC, CEC, ATEX 137, IEC 60079-14, etc.).

**M12 PROFIBUS cable plug****Warning – Risk to persons!**

The M12 plug is not approved for use with combustible dusts. In Zone 2, the plug may only be operated with energy-limited circuits (nL) such as FNICO.

**Special requirements of models ME2 / MC2 M, N (Zone 2 devices)**

The transmitter housing (rectangular or round, compact or separate) can be operated in Zone 2 with protection class "restricted breathing" (nR). In such cases, please take note of the following:

**Warning – Risk to persons!**

The user must check the device in accordance with IEC 60079-15 each time installation or maintenance has been performed, or each time the housing has been opened.

Switch off the voltage supply and wait for at least two minutes before opening the housing. Then remove a cable gland which is not being used. Cable glands certified to ATEX or IECEx are usually used, e.g., M20 x 1.5 or 1/2" NPT thread. The device being used to test the pressure is then attached to this gland. The user is responsible for ensuring that the device is sealed and installed correctly.

Re-insert the gland following the pressure test.

Before the supply power is switched on again, the housing, seals, thread, and cable entries must be subjected to a visual inspection. There must be no signs of any damage.

**Notice - Potential damage to parts!**

When selecting the installation site, ensure that the housing will not be exposed to direct sunlight. The ambient temperature limits must be observed. If direct sunlight cannot be avoided, appropriate sun protection equipment must be installed.

For FNICO or FISCO installations, the number of devices must be limited as per the applicable standard.

## 6 Parameterization

After the power to the device is switched on, a number of self-check routines are executed automatically. Subsequently, the standard display (process information) appears. The configuration of the display can be defined by the user.

### 6.1 Data entry

Data can be entered in various languages using three keys on the transmitter.

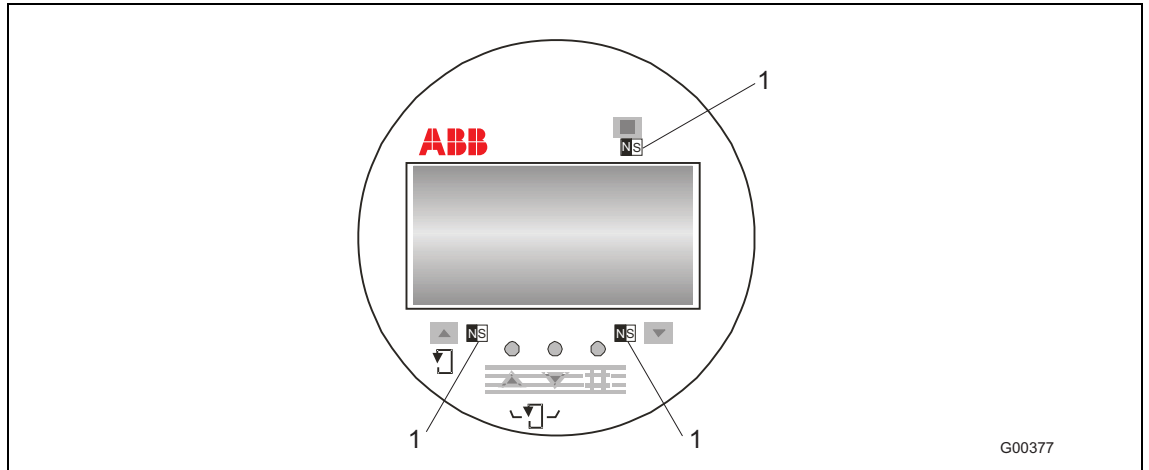

Fig. 12: Transmitter keypad and display

1 Points for inserting the magnet stick

The magnet stick can be used to configure the device even when the housing cover is closed.



#### Warning – General risks!

When the transmitter housing is open, EMC protection and protection against accidental contact are suspended.

When entering data, the transmitter remains online, i.e., current and pulse outputs still show the current operating mode. The functions of the individual keys are explained below:

- |  |        |  |
|--|--------|--|
|  | C/CE   | Toggle between operating mode and menu.  |
|  | STEP ↓ | The STEP key is one of two arrow keys. Use STEP to scroll forward through the menu. All the required parameters can be called up.  |
|  | DATA ↑ | The DATA key is one of two arrow keys. Use DATA to scroll backward through the menu. All the required parameters can be called up.   |
|  | ENTER  | The ENTER function requires that both arrow keys, STEP and DATA, be pressed simultaneously. ENTER has the following functions: <ul style="list-style-type: none"> <li>• Access the parameter to be changed and set the new, selected, or default parameter.</li> </ul> |

The ENTER function is effective for approx. 10 s only. If a new value is not entered within 10 s, the transmitter display reverts to the old value.

### **Initiating the ENTER function when using the magnet stick for operation**

The ENTER function is initiated when the DATA/ENTER sensor is activated for longer than 3 seconds. The display flashes to indicate that the function is active.

There are two different methods of entering data:

- Numeric entry
- Entry from predefined table



### **Important**

When entering data, the values are checked for plausibility and, if necessary, rejected with an appropriate message.

**6.2 Entering data in short form**

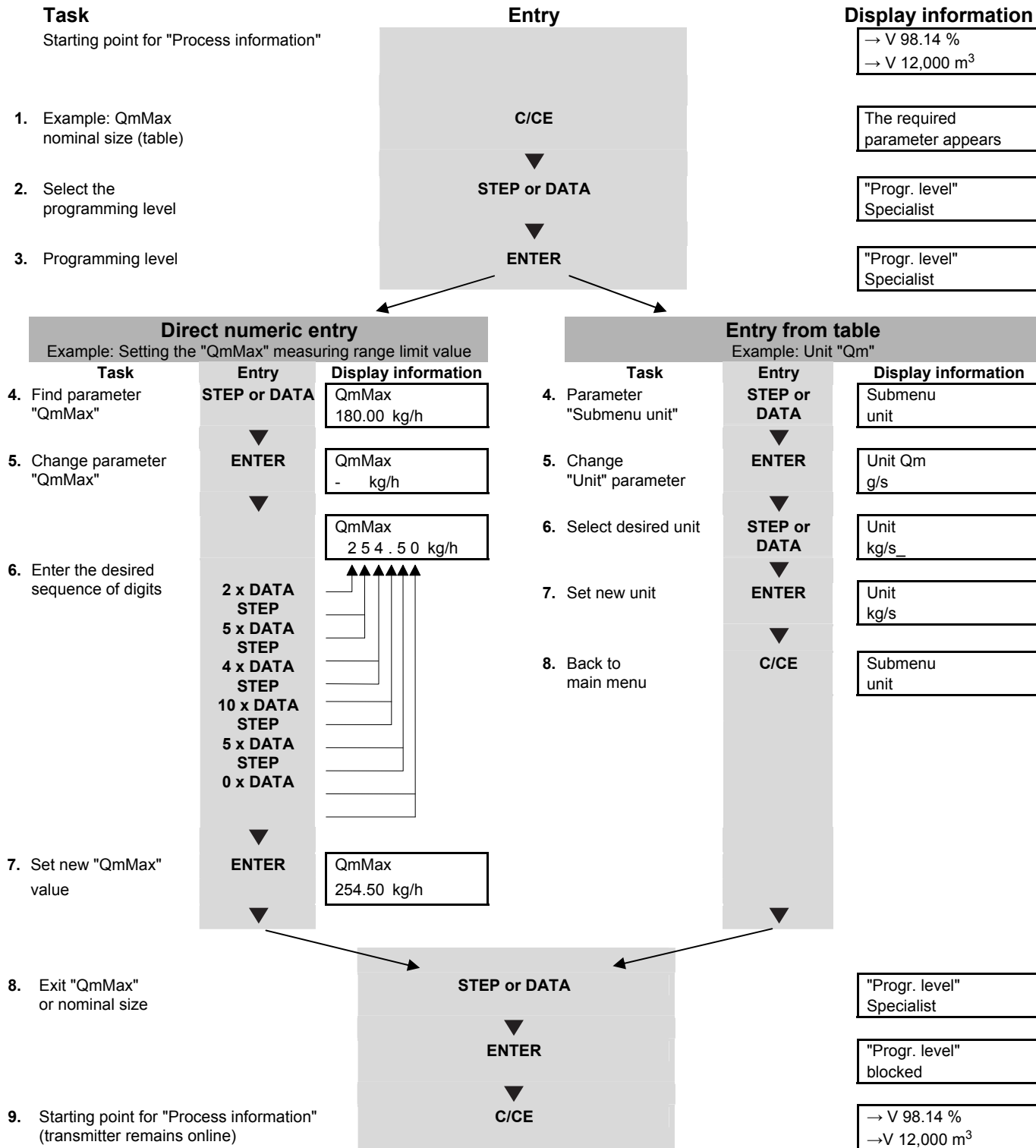





## 7 Appendix

### 7.1 Other applicable documents

- Data sheet (D184S068Uxx)
- Operating Instruction (D184B111Uxx)
- Ex safety instructions (SM/FCM2000/FM/CSA)
- Interface description for devices with HART communication (D184B108U07 / 08)
- Interface description for devices with PROFIBUS PA communication (D184B093U33 / 34)
- Interface description for devices with FOUNDATION Fieldbus communication (D184B093U35 / 36)

### 7.2 Approvals and certifications

CE mark		<p>The version of the device in your possession meets the requirements of the following European directives:</p> <ul style="list-style-type: none"> <li>- EMC Directive 2004/108/EC</li> <li>- Low Voltage Directive 2006/95/EC</li> <li>- Pressure Equipment Directive (PED) 97/23/EC</li> </ul> <p>Pressure equipment does <u>not</u> feature a CE mark indicating PED compliance on the factory tag if the following conditions prevail:</p> <ul style="list-style-type: none"> <li>- The maximum permissible pressure (PS) is less than 0.5 bar.</li> <li>- Due to insignificant pressure risks (nominal size <math>\leq</math> DN 25/1"), no approval procedures are required.</li> </ul>
Explosion protection	  	<p>Designation relating to intended use in potentially explosive atmospheres in compliance with:</p> <ul style="list-style-type: none"> <li>- ATEX Directive (marking in addition to CE marking)</li> <li>- IEC standards</li> <li>- <math>c</math>FM<sub>US</sub> Approvals for Canada and United States</li> </ul>



#### Important (Notice)

All documentation, declarations of conformity, and certificates are available in ABB's download area.

[www.abb.com/flow](http://www.abb.com/flow)



**EG-Konformitätserklärung  
EC-Declaration of Conformity**

Hiermit bestätigen wir die Übereinstimmung der aufgeführten Geräte mit den Richtlinien des Rates der Europäischen Gemeinschaft, welche mit dem CE-Zeichen gekennzeichnet sind. Die Sicherheits- und Installationshinweise der Produktdokumentation sind zu beachten.

*We herewith confirm that the listed instruments are in compliance with the council directives of the European Community and are marked with the CE marking. The safety and installation requirements of the product documentation must be observed.*

Hersteller: <i>Manufacturer:</i>	ABB Automation Products GmbH, Dransfelder Straße 2, 37079 Göttingen - Germany
Gerät: <i>Device:</i>	Masse-Durchflussmesser CoriolisMaster <i>Mass Flowmeter CoriolisMaster</i>
Modellnr.: <i>Model no.:</i>	FCM2_ ; MC2_ ; ME2_ ; MS2_ , ohne FM Zulassung <i>FCM2_ ; MC2_ ; ME2_ ; MS2_ , without FM approval</i>
Richtlinie: <i>Directive:</i>	EMV Richtlinie 20004/108/EG <i>EMC directive 2004/108/EC</i>
Europäische Norm: <i>European Standard:</i>	EN 61326-1, 10/2006 * EN 61326-2-3, 05/2007 * <i>EN 61326-1, 10/2006 * EN 61326-2-3, 05/2007 *</i>
Richtlinie: <i>Directive:</i>	Niederspannungsrichtlinie 2006/95/EG <i>Low voltage directive 2006/95/EC</i>
Europäische Norm: <i>European Standard:</i>	EN 61010-1, 08/2002 * <i>EN 61010-1, 08/2002 *</i>

\* einschließlich Nachträge / *including alterations*

Göttingen, 03. Februar 2009

  
ppa. Dr. Dieter Binz  
(R&D Manager)

  
i.A. Dirk Steckel  
(R&D Electrical Safety)

**ABB Automation Products GmbH**

BZ-13-5109, Rev.05, 12403

Postanschrift:  
Dransfelder Str. 2  
D-37079 Göttingen

Besuchsanschrift:  
Dransfelder Str. 2  
D-37079 Göttingen  
Telefon +49 551 905 0  
Telefax+49 551 905 777  
Internet: <http://www.abb.com/de>

Sitz der Gesellschaft:  
Ladenburg  
Registergericht:  
Amtsgericht Mannheim  
Handelsregister:  
HRB 700229  
USt-IdNr.: DE 115 300 097

Vorsitz des Aufsichtsrates:  
Hans-Georg Krabbe  
Geschäftsführung:  
Christian Wendler

Bankverbindung:  
Commerzbank AG Frankfurt  
Konto: 589 635 200  
BLZ: 500 400 00



**EG-Konformitätserklärung**  
**EC-Certificate of Compliance**



Hiermit bestätigen wir die Übereinstimmung der  
*Herewith we confirm that our*

**Masse-Durchflußmesser**  
**Mass Flowmeter :**  
**Modell Serie FCM2000 Coriolis Master**  
*Model Series FCM2000 Coriolis Master*

mit den grundlegenden Sicherheits- und Gesundheitsanforderungen gem. der Richtlinie 94/9/EG des Rates der Europäischen Gemeinschaft. Die Sicherheits- und Installationshinweise der Produktdokumentation sind zu beachten.  
*are in compliance with the Essential Health and Safety Requirements with refer to the council directives 94/9/EC of the European Community. The safety and installation requirements of the product documentation must be observed.*

Die Masse- Durchflussmesser basieren auf dem Coriolis- Prinzip.  
*The Mass Flowmeter is based on the Coriolis- Principle.*

Geräte-Kennzeichnung:  
*Apparatus code:*

<p><b>Baumusterprüfbescheinigung:</b> <i>Type Examination Certificate:</i> <b>KEMA 08ATEX0151 X</b></p> <p><b>MC21 :</b> II 2D Ex tD A21 IP6X T115 °C ..... Tfluid ; II 3G Ex nA II T6 ..T2 <b>MC23 :</b> II 2D Ex tD A21 IP6X T115 °C.... Tfluid ; II 3G Ex nA nR II T6 ..T2; II 3G Ex nA nR [nL] II T6..T2; FNICO field device <b>ME21 :</b> II 2 D Ex tD A21 IP6X T115 °C; II 3 G Ex nR II T6; II 3 G Ex nR [nL] IIC T6; FNICO field device</p>	<p><b>EG-Baumusterprüfbescheinigung:</b> <i>EC-Type Examination Certificate:</i> <b>KEMA 08ATEX0150 X</b></p> <p><b>MC27 :</b> II 2G Ex d e [ia] [ib] IIC T6 ..T2;II 2G Ex d e [ib] IICT6..T2; II 1/2G Ex d e [ib] IIC T6..T2; II 1/2G Ex d e [ia] [ib] IICT6..T2; II 2D Ex tD A21 IP6X T115 °C.. Tfluid; II 2 D Ex tD[iaD] A21 IP6X T115°C; FISCO field device; II 2D Ex A21 IP6X T115; II 2D Ex tD [ibD] A21 IP6X T115°C <b>ME24, ME25 :</b>II 3(2)G Ex nR [ib] IIC T6; FNICO field device; II 3(2)G Ex nR[ib][nL]IICT6; II 2D Ex tD A21 IP6X T115 °C <b>ME26 :</b>II 2G Ex d e [ia] [ib] IIC T6..Tfluid; II 2G Ex d e [ib] IIC T6; II 2D Ex tD A21 IP6X T115 °C; II 2D Ex tD [iaD] A21 IP6X T115 °C; II 2D Ex tD[ibD]A21 IP6X T115 °C ;FISCO field device <b>ME27, ME28 :</b> II 2G Ex d e [ia] [ib] IIC T6; II 2G Ex d e [ib] IICT6;II 2D Ex tD [iaD] [ibD] A21 IP6X T115 °C ; II 2D Ex tD [ibD] A21 IP6X T115 °C ; FISCO Field device <b>MC26 :</b> II 2D Ex e mb [ia] IIC T6..T2 ; II 1/2G Ex e mb [ia] IIC T6 ..T2 ; <b>MS26 :</b> II 2 G Ex ib IIC T5 ... T3</p>
--	--

Benannte Stelle: **KEMA Quality B.V. No. 0344**  
*Notified Body:*

Sicherheitstechnische Daten: **siehe EG-Baumusterprüfbescheinigung, Baumusterprüfbescheinigung, Betriebsanleitung**  
*Safety values: refer to EC-Type Examination Certificate, Type Examination Certificate, Operating Instruction*

Göttingen, 03. Februar 2009

**Dr. Dieter Binz**  
(R&D Manager)

**Karl-Heinz Rackebrandt**  
(R&D Manager Sensors)

**ABB Automation Products GmbH**

BZ-13-8020-Rev.01, 12437

Postanschrift:  
Dramfelder Str. 2  
D-37079 Göttingen

Besuchanschrift:  
Dramfelder Str. 2  
D-37079 Göttingen  
Telefon +49 551 905 0  
Telefax+49 551 905 777  
Internet: <http://www.abb.com/de>

Sitz der Gesellschaft:  
Ladenburg  
Registergericht:  
Amtsgericht Mannheim  
Handelsregister:  
HRB 700229  
USt-IdNr.: DE 115 300 097

Vorsitzender des Aufsichtsrats:  
Hans-Georg Krabbe  
Geschäftsführung:  
Christian Wendler

Bankverbindung:  
Commerzbank AG Frankfurt  
Konto: 589 635 200  
BLZ: 500 400 00



**EG-Konformitätserklärung**  
**EC-Declaration of Conformity**

Hiermit bestätigen wir die Übereinstimmung des aufgeführten Gerätes mit den Richtlinien des Rates der Europäischen Gemeinschaft, welche mit dem CE-Zeichen gekennzeichnet sind. Die Sicherheits- und Installationshinweise der Produktdokumentation sind zu beachten.

*Herewith we confirm that the listed instrument is in compliance with the council directives of the European Community and are marked with the CE marking. The safety and installation requirements of the product documentation must be observed.*

Hersteller: <i>manufacturer:</i>	ABB Automation Products GmbH, 37070 Göttingen - Germany
Modell: <i>model:</i>	FCM 2000 (Trio Mass) FCM 2000 (Trio Mass)
Richtlinie: <i>directive:</i>	Druckgeräterichtlinie 97/23/EG <i>pressure equipment directive 97/23/EC</i>
Einstufung: <i>classification:</i>	Ausrüstungsteile von Rohrleitungen <i>pipng accessories</i>
Normengrundlage: <i>technical standard:</i>	AD 2000 Merkblätter
Konformitätsbewertungsverfahren: <i>conformity assessment procedure:</i>	B1 (EG-Entwurfsprüfung) + D (Qualitätssicherung Produktion) <i>B1 (EC design-examination) + D (production quality assurance)</i>
EG-Entwurfsprüfbescheinigung: <i>EC design-examination certificate:</i>	Nr. 07 202 0124 Z 052/2/0001 Nr. 07 202 4534 Z 0606/3/H Nr. 07 202 STK1 Z 0438/8/D/01 Nr. 07 202 STK1 Z 0577/8/D/01
benannte Stelle: <i>notified body:</i>	TÜV Nord Systems GmbH & Co. KG Große Bahnstr. 31 22525 Hamburg - Germany
Kennnummer: <i>identification no.</i>	0045

Göttingen, den 04.06.2008

ppa   
 (D. Binz, Entwicklungsleiter APR Göttingen)

i.A.   
 L. Deppe, Mech. Sicherheit

---

ABB has Sales & Customer Support  
expertise in over 100 countries worldwide.

[www.abb.com/flow](http://www.abb.com/flow)

The Company's policy is one of continuous product  
improvement and the right is reserved to modify the  
information contained herein without notice.

Printed in the Fed. Rep. of Germany (10.2011)

© ABB 2011

3KXF411003R4401



**ABB Limited**

Oldends Lane, Stonehouse  
Gloucestershire, GL10 3TA  
UK

Tel: +44 (0)1453 826661  
Fax: +44 (0)1453 829671

**ABB Inc.**

125 E. County Line  
Road  
Warminster, PA 18974  
USA

Tel: +1 215 674 6000  
Fax: +1 215 674 7183

**ABB Automation Products GmbH**

Dransfelder Str. 2  
37079 Goettingen  
Germany

Tel: +49 551 905-534  
Fax: +49 551 905-555