

Models 265GS/GC/GM/GG/GJ/GN/GR/Gx
Models 265AS/AC/AM/AG/AJ/AN/AR/Ax



HART 
COMMUNICATION PROTOCOL

Pressure Transmitter 265Gx, 265Ax

Operating Instruction

IM/265Gx/Ax-EN-07

08.2011

Translation of the original instruction

Manufacturer:

ABB Automation Products GmbH

Schillerstraße 72

32425 Minden

Germany

Tel.: +49 551 905-534

Fax: +49 551 905-555

Customer service center

Phone: +49 180 5 222 580

Fax: +49 621 381 931-29031

automation.service@de.abb.com

© Copyright 2011 by ABB Automation Products GmbH

Subject to changes without notice

This document is protected by copyright. It assists the user in safe and efficient operation of the device. The contents of this document, whether whole or in part, may not be copied or reproduced without prior approval by the copyright holder.

1	Safety	6
1.1	General information and notes for the reader	6
1.2	Intended use.....	6
1.3	Technical limit values	6
1.4	Improper use	7
1.5	Target groups and qualifications	7
1.6	Warranty provisions.....	7
1.7	Plates and symbols	8
1.7.1	Safety-/ warning symbols, note symbols.....	8
1.8	Name plate	9
1.8.1	Compliance with Pressure Equipment Directive (97/23/EC)	11
1.9	Transport and storage	12
1.10	Safety instructions for electrical installation	12
1.11	Safety information for inspection and maintenance	12
1.12	Returning devices.....	13
1.13	Integrated management system.....	13
1.14	Disposal.....	13
1.14.1	Information on WEEE Directive 2002/96/EC (Waste Electrical and Electronic Equipment).....	13
1.14.2	RoHS Directive 2002/95/EC	14
2	Use in potentially explosive atmospheres	15
2.1	Type-examination certificate/Declaration of conformity	15
2.2	Type of protection "intrinsic safety Ex i"	15
2.3	Use in areas with combustible dust.....	16
2.4	Category 3 for use in "Zone 2"	16
2.5	Type of protection "flameproof enclosure Ex d"	17
2.6	Type of protection "intrinsic safety i", "flameproof enclosure d", "protection by enclosure tD", and "non-sparking nA"	18
2.7	Canadian Standards Association (CSA): "Explosion-proof"	18
2.8	Aspects of "Ex safety" and "IP protection" for Australian applications.....	19
3	Design and function	21
3.1	Principle of operation and construction	22
4	Mounting	25
4.1	General.....	25
4.2	IP designation.....	25
4.3	Pressure transmitter	26
4.4	Sealing and screw connections.....	26
4.5	Moisture.....	27
4.6	Impulse line	27
5	Electrical connections	28
5.1	Cable connection.....	28
5.2	Electrical connection in the cable connection area	29
5.3	Electrical connection with plug	31
5.4	Assembling and connecting the socket connector	32
5.5	Protective conductor / Grounding.....	33
5.6	Integrated lightning protection (optional).....	33
5.7	Communication setup.....	34
5.8	Connecting cable.....	36

Contents

5.9	PROFIBUS PA pressure transmitter	37
6	Commissioning	38
6.1	Output signal	39
6.2	Write protection	39
6.3	Correcting the lower range value / zero shift.....	40
6.4	Turning the housing in relation to the measuring equipment.....	41
6.5	Installing / Removing the button unit	41
6.6	Installing / Removing the LCD display	42
6.7	Securing the housing cover with Ex d.....	44
6.8	Sensor ventilation.....	45
6.9	Operation.....	46
6.9.1	Operation using the control buttons on the transmitter.....	46
7	Configuration.....	47
7.1	Factory settings	47
7.1.1	Transmitter with HART communication and 4 ... 20 mA output current.....	47
7.1.2	Transmitter with PROFIBUS PA communication.....	48
7.1.3	Transmitter with FOUNDATION Fieldbus communication.....	49
7.2	Configuration types	49
7.3	Configuring the parameters without an LCD display.....	50
7.4	Configuration with the LCD display	52
7.4.1	Offset shift (OFFSET SHIFT).....	53
7.4.2	Damping (DAMPING).....	54
7.4.3	Characteristic (FUNCTION).....	54
7.4.4	Fieldbus address (ADDRESS).....	54
7.5	Layout and contents of the LCD display	55
7.5.1	Displaying a physical value.....	55
7.5.2	Menu structure	57
7.6	Menu-controlled pressure transmitter programming.....	59
7.6.1	Parameter description.....	60
7.7	Configuration with the PC / laptop or handheld terminal.....	62
7.8	Configuration with the graphical user interface (DTM).....	64
7.8.1	System requirements	64
7.8.2	Setting the damping value	65
7.8.3	Correcting the zero shift.....	65
7.8.4	Setting the lower and upper range limit values.....	65
8	Ex relevant specifications	66
8.1	Potentially explosive atmospheres.....	66
9	Specifications	70
9.1	Functional specifications	70
9.2	Operating limits	71
9.3	Pressure limits.....	71
9.4	Environmental limits	72
9.5	Electrical data and options	72
9.6	Measuring accuracy	74
9.7	Operating influences	74
9.8	Technical specification	75
9.9	Mounting dimensions (not design data)	76
9.9.1	Pressure transmitter with barrel housing	76

9.9.2	Pressure transmitter with DIN housing	77
9.9.3	Pressure transmitter with front-bonded diaphragm (barrel housing)	78
9.9.4	Pressure transmitter with ball valve connection (barrel housing)	79
9.9.5	Mounting with bracket for barrel housing (option).....	80
9.9.6	Mounting with bracket for DIN housing (option).....	81
10	Maintenance / Repair	82
10.1	Removal	83
10.1.1	Removing the electronics.....	83
10.1.2	Screw torques for the process connection.....	83
11	Appendix	84
11.1	Approvals and certifications	84
12	Index	87

1 Safety

1.1 General information and notes for the reader

You must read these instructions carefully prior to installing and commissioning the device. These instructions are an important part of the product and must be kept for future reference. These instructions are intended as an overview and do not contain detailed information on all designs for this product or every possible aspect of installation, operation and maintenance. For additional information or if specific problems occur that are not discussed in these instructions, contact the manufacturer.

The content of these instructions is neither part of any previous or existing agreement, promise or legal relationship nor is it intended to change the same.

This product is built based on state-of-the-art technology and is operationally safe. It has been tested and left the factory in perfect working order from a safety perspective. The information in the manual must be observed and followed in order to maintain this state throughout the period of operation.

Modifications and repairs to the product may only be performed if expressly permitted by these instructions.

Only by observing all of the safety instructions and all safety/warning symbols in these instructions can optimum protection of both personnel and the environment, as well as safe and fault-free operation of the device, be ensured.

Information and symbols directly on the product must be observed. They may not be removed and must be fully legible at all times.

1.2 Intended use

265A pressure transmitters measure the absolute pressure and 265G pressure transmitters the gauge pressure or level of gases, vapors, and liquids. For information on measuring ranges and permissible overload, refer to the section "Technical data".

1.3 Technical limit values

The device is designed for use exclusively within the values stated on the name plate and within the technical limit values specified on the data sheets.

The following technical limit values must be observed:

- The permitted pressure may not be exceeded.
- The maximum operating temperature may not be exceeded.
- The permitted operating temperature may not be exceeded.
- The housing protection type must be observed.

1.4 Improper use

It is prohibited to use the device for the following purposes:

- As a climbing aid, e.g., for mounting purposes
- As a support for external loads, e.g., as a support for pipes, etc.
- Adding material, e.g., by painting over the name plate or welding/soldering on parts
- Removing material, e.g., by drilling the housing.

1.5 Target groups and qualifications

Installation, commissioning, and maintenance of the product may only be performed by trained specialist personnel who have been authorized by the plant operator to do so. The specialist personnel must have read and understood the manual and comply with its instructions.

Prior to using corrosive and abrasive materials for measurement purposes, the operator must check the level of resistance of all parts coming into contact with the materials to be measured. ABB Automation Products GmbH will gladly support you in selecting the materials, but cannot accept any liability in doing so.

The operators must strictly observe the applicable national regulations with regards to installation, function tests, repairs, and maintenance of electrical products.

1.6 Warranty provisions

Using the device in a manner that does not fall within the scope of its intended use, disregarding this instruction, using underqualified personnel, or making unauthorized alterations releases the manufacturer from liability for any resulting damage. This renders the manufacturer's warranty null and void.

1.7 Plates and symbols

1.7.1 Safety-/ warning symbols, note symbols



DANGER – <Serious damage to health / risk to life>

This symbol in conjunction with the signal word "Danger" indicates an imminent danger. Failure to observe this safety information will result in death or severe injury.



DANGER – <Serious damage to health / risk to life>

This symbol in conjunction with the signal word "Danger" indicates an imminent electrical hazard. Failure to observe this safety information will result in death or severe injury.



WARNING – <Bodily injury>

This symbol in conjunction with the signal word "Warning" indicates a possibly dangerous situation. Failure to observe this safety information may result in death or severe injury.



WARNING – <Bodily injury>

This symbol in conjunction with the signal word "Warning" indicates a potential electrical hazard. Failure to observe this safety information may result in death or severe injury.



CAUTION – <Minor injury>

This symbol in conjunction with the signal word "Caution" indicates a possibly dangerous situation. Failure to observe this safety information may result in minor or moderate injury. This may also be used for property damage warnings.



NOTICE – <Property damage>!

The symbol indicates a potentially damaging situation.

Failure to observe this safety information may result in damage to or destruction of the product and/or other system components.



IMPORTANT (NOTE)

This symbol indicates operator tips, particularly useful information, or important information about the product or its further uses. It does not indicate a dangerous or damaging situation.

1.8 Name plate

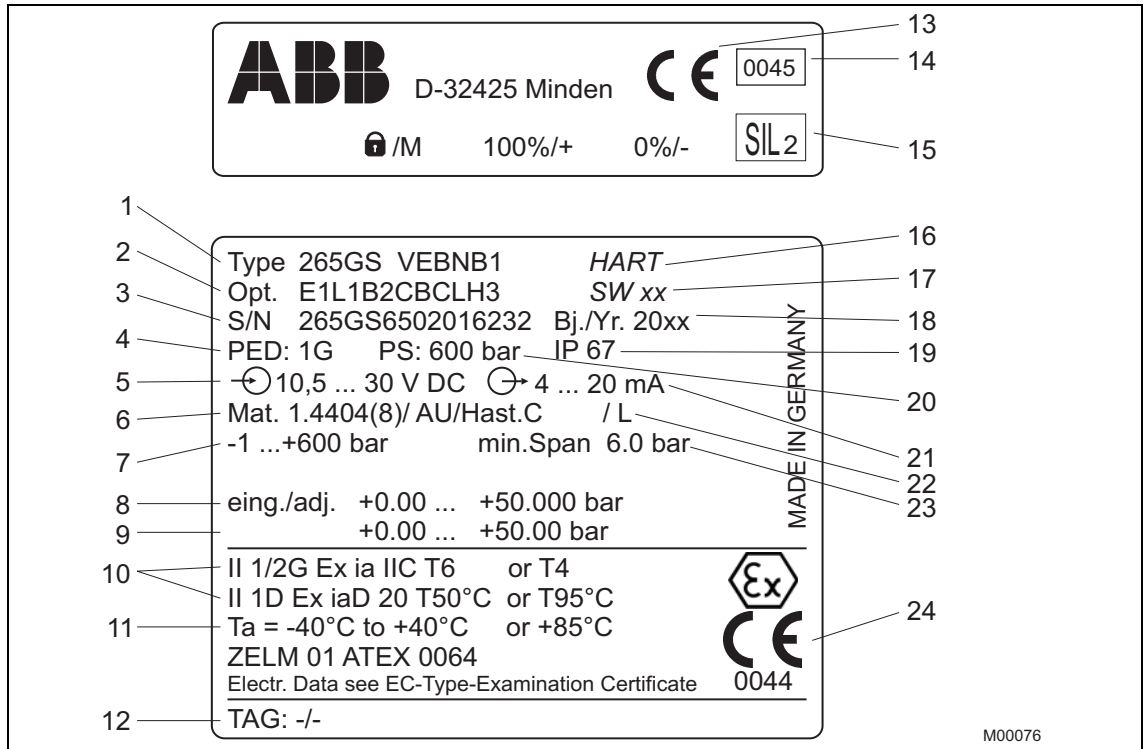

Fig. 1: Example: Name plate for 265G, 265A transmitter

- | | |
|--|---|
| <ul style="list-style-type: none"> 1 Device type/order code (for information on the individual letters/numbers, refer to the information on the order confirmation or device data sheet) 2 Options – additional information on the order code. 3 Device serial number (factory no.) 4 Identification code with reference to the Pressure Equipment Directive (SEP or 1G). See the section "Compliance with the Pressure Equipment Directive (97/23/EC)". 5 Power supply 6 Parts that come into contact with medium 7 Lower to upper range limit (LRL to URL) 8 Set span 9 HART output (process variable) 10 Ex design designation (optional) 11 No. of EC-type-examination certificate 12 Tag (max. 32 characters) | <ul style="list-style-type: none"> 13 EC conformity mark 14 Identification number of the notified body with reference to the Pressure Equipment Directive. See the section "Compliance with the Pressure Equipment Directive (97/23/EC)". 15 "SIL2" identification code (optional) 16 Device communication type 17 Software version 18 Year of manufacture 19 Ingress protection 20 Permissible pressure (static) 21 Output signal 22 Code for filling liquid 23 Minimum span 24 Identification number of the notified body with reference to ATEX certification (optional) |
|--|---|

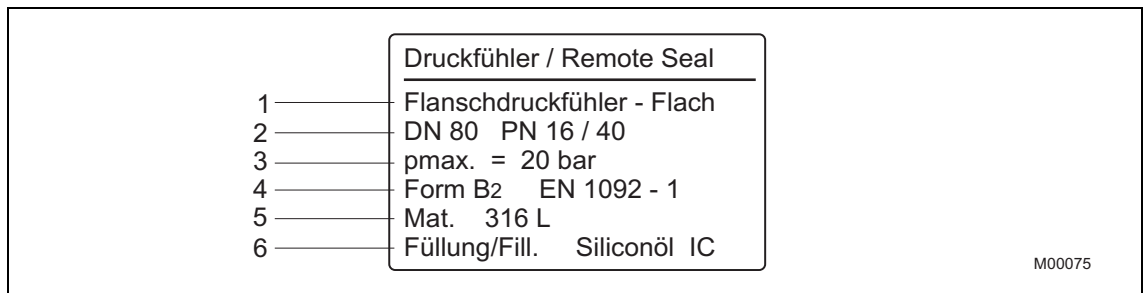

Fig. 2: Example: Additional name plate for devices with direct mount remote seals (optional)

- | | |
|-----------------------------------|---|
| 1 Remote seal type | 5 Materials that come into contact with medium |
| 2 Meter size and nominal pressure | 6 Filling liquid in the remote seal system; ID letters for filling liquid |
| 3 Max. overload | |
| 4 Sealing surface form | |

1.8.1 Compliance with Pressure Equipment Directive (97/23/EC)

Devices with PS > 200 bar (20 MPa)

Devices with a permissible pressure of PS > 200 bar (20 MPa) have been tested for conformity by the Technical Supervisory Association TÜV NORD (0045) in accordance with module H and can be used for fluids of group 1 (PED: 1G).

The name plate bears the following identification codes:

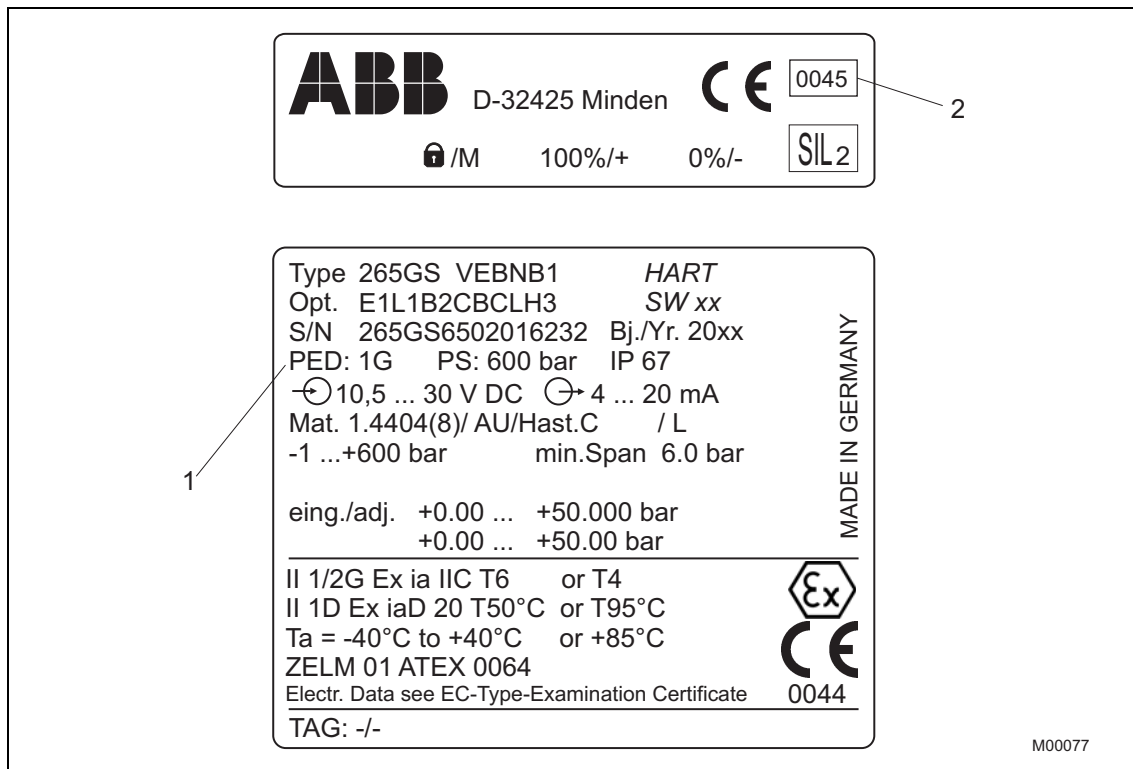

Fig. 3

- 1 PED: 1G (at PS > 20 MPa)
SEP (at PS ≤ 20 MPa)
- 2 CE 0045: Identification number of the notified body with reference to the Pressure Equipment Directive (for PS > 20 MPa only)

Devices with PS ≤ 200 bar (20 MPa)

Devices with a permissible pressure of PS ≤ 200 bar (20 MPa) conform to Sec. 3 Para. (3) and have not been tested for conformity. The devices have been constructed and manufactured according to sound engineering practice (SEP).

The CE marking on the device does not refer to the Pressure Equipment Directive.

The name plate thus bears the identification code PED: SEP.

1.9 Transport and storage

- After unpacking the pressure transmitter, check the device for transport damage.
- Check the packaging material for accessories.
- During intermediate storage or transport, store the pressure transmitter in the original packaging only.

For information on permissible ambient conditions for storage and transport, see "Technical data". Although there is no limit on the duration of storage, the warranty conditions stipulated in the order confirmation from the supplier still apply.

1.10 Safety instructions for electrical installation

The electrical connection may only be made by authorized specialist personnel according to the electrical plans.

The electrical connection information in the manual must be observed; otherwise, the electrical protection type may be adversely affected.

Ground the measurement system according to requirements.

1.11 Safety information for inspection and maintenance



WARNING – Risk to persons

There is no EMC protection or protection against accidental contact when the housing cover is open. There are electric circuits within the housing which are dangerous if touched. Therefore, the supply power must be switched off before opening the housing cover.



WARNING – Risk to persons

The device can be operated at high pressure and with aggressive media. Any medium that squirts out can cause severe injuries. Depressurize the pipeline / tank before opening the transmitter connection.

Corrective maintenance work may only be performed by trained personnel.

- Before removing the device, depressurize it and any adjacent lines or containers.
- Check whether hazardous materials have been used as materials to be measured before opening the device. Residual amounts of hazardous material may still be present in the device and could escape when the device is opened.
- Within the scope of operator responsibility, check the following as part of a regular inspection:
 - Pressure-bearing walls/lining of the pressure device
 - Measurement-related function
 - Leaktightness
 - Wear (corrosion)

1.12 Returning devices

Use the original packaging or suitably secure shipping containers if you need to return the device for repair or recalibration purposes. Fill out the return form (see the Appendix) and include this with the device.

According to EC guidelines for hazardous materials, the owner of hazardous waste is responsible for its disposal or must observe the following regulations for shipping purposes:

All devices delivered to ABB Automation Products GmbH must be free from any hazardous materials (acids, alkalis, solvents, etc.).

Please contact Customer Center Service acc. to page 2 for nearest service location.

1.13 Integrated management system

ABB Automation Products GmbH operates an integrated management system, consisting of:

- Quality management system to ISO 9001:2008
- Environmental management system to ISO 14001:2004
- Occupational health and safety management system to BS OHSAS 18001:2007 and
- Data and information protection management system

Environmental awareness is an important part of our company policy.

Our products and solutions are intended to have a minimal impact on the environment and on people during manufacturing, storage, transport, use, and disposal.

This includes the environmentally-friendly use of natural resources. We conduct an open dialog with the public through our publications.

1.14 Disposal

This product is manufactured from materials that can be reused by specialist recycling companies.

1.14.1 Information on WEEE Directive 2002/96/EC (Waste Electrical and Electronic Equipment)

This product is not subject to WEEE Directive 2002/96/EC or relevant national laws (e.g., ElektroG in Germany).

The product must be disposed of at a specialist recycling facility. Do not use municipal garbage collection points. According to the WEEE Directive 2002/96/EC, only products used in private applications may be disposed of at municipal garbage facilities. Proper disposal prevents negative effects on people and the environment, and supports the reuse of valuable raw materials.

If it is not possible to dispose of old equipment properly, ABB Service can accept and dispose of returns for a fee.

1.14.2 RoHS Directive 2002/95/EC

With the Electrical and Electronic Equipment Act (ElektroG) in Germany, the European Directives 2002/96/EC (WEEE) and 2002/95/EC (RoHS) are translated into national law. ElektroG defines the products that are subject to regulated collection and disposal or reuse in the event of disposal or at the end of their service life. ElektroG also prohibits the marketing of electrical and electronic equipment that contains certain amounts of lead, cadmium, mercury, hexavalent chromium, polybrominated biphenyls (PBB), and polybrominated diphenyl ethers (PBDE) (also known as hazardous substances with restricted uses).

The products provided by ABB Automation Products GmbH do not fall within the current scope of the directive on waste from electrical and electronic equipment according to ElektroG. If the necessary components are available on the market at the right time, in the future these substances will no longer be used in new product development.

2 Use in potentially explosive atmospheres

According to Directive 94/9/EC (ATEX):

When installing explosion-proof transmitters (electrical connection, grounding / equipotential bonding, etc.), national regulations, DIN / VDE standards, explosion protection directives, and the Ex test certificate of the device must be observed. The certified explosion-proof designation for the transmitter is provided on the name plate.

2.1 Type-examination certificate/Declaration of conformity

For explosion-proof transmitter models, the EC-type-examination certificate or declaration of conformity forms an integral part of these operating instructions.

2.2 Type of protection "intrinsic safety Ex i"

- Only intrinsically safe devices may be installed in the transmitter signal circuit. The signal circuit can be interrupted while the transmitter is in operation (e.g., clamping/unclamping signal lines).
- The housing may be opened during operation.
- Transmitters with and without remote seals and featuring type of protection "intrinsic safety Ex i" may be directly integrated into the partition separating Zone 0 and Zone 1 (sensor diaphragm in Zone 0, transmitter in Zone 1), provided that the power is supplied via an intrinsically safe circuit (Ex ia or Ex ib). (measuring ranges ≤ 400 mbar with Ex ia only)
- Test circuit (terminals "TEST +/-"): With type of protection "intrinsic safety", connections should only be established to passive, intrinsically safe circuits. The category, explosion group, and maximum values for U_o , I_o , and P_o of the intrinsically safe test circuit can be determined on the basis of the intrinsically safe signal circuit connected.



IMPORTANT (NOTE)

Please observe the rules governing interconnection.

2.3 Use in areas with combustible dust

Installation must be performed in accordance with EN 61241-14:2004.

- Transmitters can only be connected using cable glands certified in accordance with Directive 94/9/EC (ATEX) (not included in scope of delivery). The cable gland must conform to IP 67 degree of protection. The smoldering temperature of the dust must be at least 75 K above the max. surface temperature of the transmitter. The max. surface temperature is 95 °C and is obtained by adding together the max. ambient temperature (85 °C) and max. self-heating (10 K).



CAUTION - Risk

When using separating sensors with an anti-stick coating, be aware of the risk of electrostatic discharge (with consideration given to the medium and transport speed).

2.4 Category 3 for use in "Zone 2"

- The transmitter must be connected using a certified cable gland (not included in scope of delivery). The cable gland must satisfy the requirements of type of protection "increased safety Ex e" in accordance with Directive 94/9/EC (ATEX). Additionally, the conditions stipulated in the type-examination certificate for the cable gland must be observed.



WARNING - Risk of explosion!

Opening the cover presents a risk of spark formation and, therefore, explosion.

Opening the housing during operation (with the operating voltage switched on) is not permitted.

2.5 Type of protection "flameproof enclosure Ex d"

Please observe the following installation information:

- The transmitter must be connected using suitable cable and wire entries or pipeline systems, which satisfy the requirements of EN 60079-1:2007, Section 13.1 or 13.2, and for which a separate examination certificate exists.
- Openings in the housing that are not being used must be closed in accordance with EN 60079-1:2007, Section 11.9.
- Cable and wire entries, as well as plugs, which do not comply with the points stipulated above may not be used.

To align the transmitter at the measuring point (by turning by a maximum of 360°), the rotatable housing may be loosened on the shaft between the measuring equipment and housing:

1. Loosen the locking screw by a maximum of 1 rotation.
2. Align the housing.
3. Retighten the locking screw.

Before switching on the operating voltage:

1. Close the housing.
2. Secure the housing cover by turning the locking screws (hex-head socket screws) counterclockwise.
3. Secure the housing against rotating by turning the locking screw clockwise.
4. The housing cover, electronics housing, and measuring equipment may only be replaced with components that have been approved for this purpose.



CAUTION - Risk

Opening the housing during operation (with the operating voltage switched on) is not permitted.

2.6 Type of protection "intrinsic safety i", "flameproof enclosure d", "protection by enclosure tD", and "non-sparking nA"

Certificate with alternative types of protection:

A	Intrinsic safety	(Category 1/2G or 1D, Ex i)
B	Flameproof enclosure	(Category 1/2G, Ex d)
	Protection by enclosure	(Category 2D, Ex tD)
	Non-sparking	(Category 3G, Ex nA)



IMPORTANT (NOTE)

Prior to final installation, the operator must decide whether the device is to be used (A) as a device featuring type of protection "Ex ia" or "Ex iaD" (intrinsic safety) or (B) as a device featuring any of the other types of protection ("Ex d", "Ex tD", "Ex nA"). The operator must then permanently mark the selected type of usage in the appropriate box on the name plate.

Once selected, the type of protection may not be changed.

The information provided previously on the selected type of protection must be observed.



CAUTION - Risk

Failure to observe this information will have an adverse effect on explosion protection.

2.7 Canadian Standards Association (CSA): "Explosion-proof"



NOTICE - Potential damage to parts

Transmitters with LCD displays must not be used in etherized atmospheres.

2.8 Aspects of "Ex safety" and "IP protection" for Australian applications
TestSafe certificate number

ANZEx 06.3056

Ingress protection

Ex d IIC T6 IP 66 / IP 67

Ex tD A21 IP 66 / IP 67 T85 deg C

 $T_{amb} = -20 \dots 75 \text{ °C} (-4 \dots 167 \text{ °F})$

Symbol	Meaning
Ex d	Flameproof enclosure (gas)
IIC	Gas group
T6	Transmitter temperature class (corresponds to max. 85 °C (185 °F) at an ambient temperature T_{amb} of 75 °C (167 °F).
Ex tD	Dust (dangerous medium)
A21	Suitable for "Zone 21"
IP 66 / IP 67	Protection type
T85 deg C	Maximum surface temperature of the transmitter at an ambient temperature T_{amb} of 75 °C (167 °F), for dust layers of up to 5 mm (0.20 inch) in thickness.

The transmitters have been certified in accordance with the following standards:

IEC 60079-0:2004 AS/NZS 60079.0:2005	Electrical apparatus for explosive gas atmospheres. Part 0: General requirements
IEC 60079-1:2003 AS/NZS 60079.1:2005	Electrical apparatus for explosive gas atmospheres. Part 1: Flameproof enclosure "d"
IEC 61241-0:2004 AS/NZS 61241.0:2005	Electrical apparatus for use in the presence of combustible dust. Part 0: General requirements
IEC 61241-1:2004 AS/NZS 61241.1:2005	Electrical apparatus for use in the presence of combustible dust. Part 1: Protection by enclosure "tD"

Notes

- Opening the housing during operation (i.e., while the operating voltage is switched on) is not permitted.
- The transmitter must be connected using a suitable cable, cable glands, or pipeline systems, which satisfy the requirements of the standards listed above and for which a separate test certificate is available.



CAUTION - Risk

Only use cables and cable glands that are approved for temperatures of 80 °C (176 °F).

- Openings in the housing that are not being used must be closed in accordance with the standards listed above.
- Before switching on the operating voltage:
 - The housing must be closed.
 - Secure the housing cover by turning the locking screws (hex-head socket screws) counterclockwise.
 - Secure the housing against rotating by turning the locking screw clockwise.
- The housing cover, electronics housing, and measuring equipment may only be replaced with components that have been approved for this purpose.

3 Design and function

The 265A and 265G digital pressure transmitters are communication-ready field devices featuring microprocessor-controlled electronics with multisensor technology.

For bidirectional communication, the devices have an FSK signal superimposed on the 4 ... 20 mA output signal (depending on their design) in accordance with the HART protocol; in the case of devices that operate on a fully digital basis, communication takes place via the PROFIBUS PA or FOUNDATION Fieldbus protocols, depending on their design.

The graphical user interface (DTM) can be used to configure, poll, and test the pressure transmitter using a PC, depending on the relevant protocol. Communication using a handheld terminal ¹⁾ is also possible, provided that the devices operate in accordance with the HART protocol.

A control unit, consisting of two buttons for setting the "lower range limit value" and "upper range limit value" parameters and a write protection switch, is available for "local" operation.

i

IMPORTANT (NOTE)

It is not possible to activate the write protection function via the control unit with the FOUNDATION Fieldbus communication type.

The "local control unit" can be used in conjunction with a built-in LCD display for external configuration and parameterization of the pressure transmitter, regardless of the selected communication protocol.

As standard, the electronics housing features a finish that is resistant to aggressive atmospheres. The process connection is made from stainless steel or Hastelloy C. The housing cover and button unit may be leaded.

The name plate contains information about the design of the pressure transmitter. A full list of the information on the name plate can be found in the previous section under "Name plate".

When making enquiries, always remember to quote the universally valid serial number (S/N) and year specified.

i

IMPORTANT (NOTE)

In the case of explosion-proof designs, a description of the Ex design is also provided.

Barrel housings: On the name plate

DIN housings: On a separate plate

Another separate plate, located in front of the "local" control unit, describes the functions of the three control elements using easily comprehensible symbols. In addition, a tag indicating the measuring points may be attached (as an option).

¹⁾ Communication / configuration / parameterization via handheld terminal / PC where type of protection "intrinsic safety" applies:
In this case, the HHT / PC must be appropriately certified; this applies even if it is only connected for a short period of time.
This proof of "intrinsic safety" must be supplied in addition to the transmitter.
With type of protection "flameproof enclosure Ex d", the handheld terminal must not be connected in a potentially explosive atmosphere.
The HHT battery must not be replaced in a potentially explosive atmosphere.

3.1 Principle of operation and construction

The pressure transmitter has a modular structure and consists of the pressure measuring cell with integrated adjustment electronics, as well as the main electronics plus control unit. Depending on the measuring range and measured variable, either a ceramic pressure sensor or a silicon pressure sensor is used.

Ceramic pressure sensor

With ceramic pressure sensors (capacitive measuring system), the applied process pressure (pe/pabs) is transferred directly to the measuring diaphragm.

Even a very slight deflection of the measuring diaphragm will change the internal output voltage of the pick-up system.

Silicon pressure sensor

With silicon pressure sensors (piezoresistive measuring system), the pressure is transferred to the silicon sensor via the isolating diaphragm and the filling liquid.

In accordance with the pressure, four doped piezoresistors in the silicon sensor change their resistance values and, therefore, the output voltage of the pick-up system.

This output voltage, which is proportionate to pressure, is transformed into an electrical signal by the adjustment electronics and main electronics.

Depending on the model, the transmitter is connected to the process by means of a G ½ B spigot (DIN EN 837-1), ½14 NPT male or female thread, front-bonded diaphragm with special thread G ½" for, e.g., a ball valve, or via various remote seals.

The transmitter operates on the basis of two-wire technology. The same wires are used for the operating voltage (device-specific, see "Technical data") and the scaled output signal (4 ... 20 mA or digital). The electrical connection is established via a cable entry or plug.

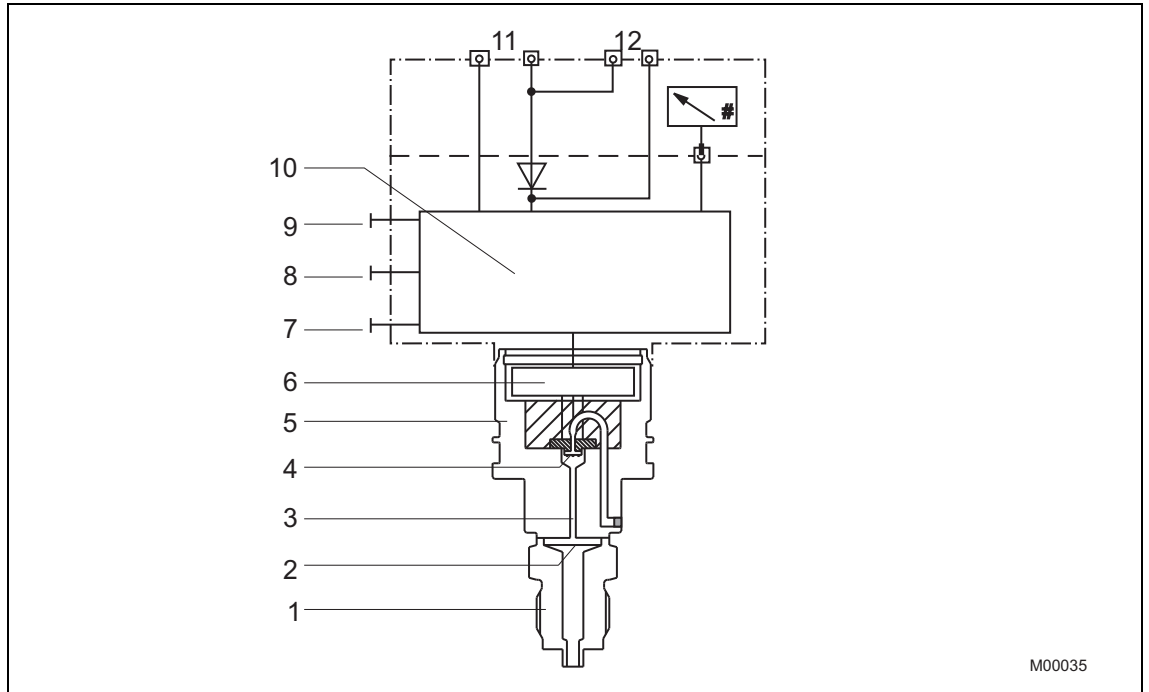

Fig. 4: 265G transmitter for pressure and fill level (in this diagram, measuring ranges ≥ 2.5 bar)

- | | |
|--------------------------|--|
| 1 Process connection | 7 Write protection |
| 2 Isolating diaphragm | 8 Span |
| 3 Filling liquid | 9 Lower range limit value |
| 4 Pressure sensor | 10 Microprocessor-controlled electronics |
| 5 Measuring equipment | 11 Output / Supply power |
| 6 Adjustment electronics | 12 Test instrument |

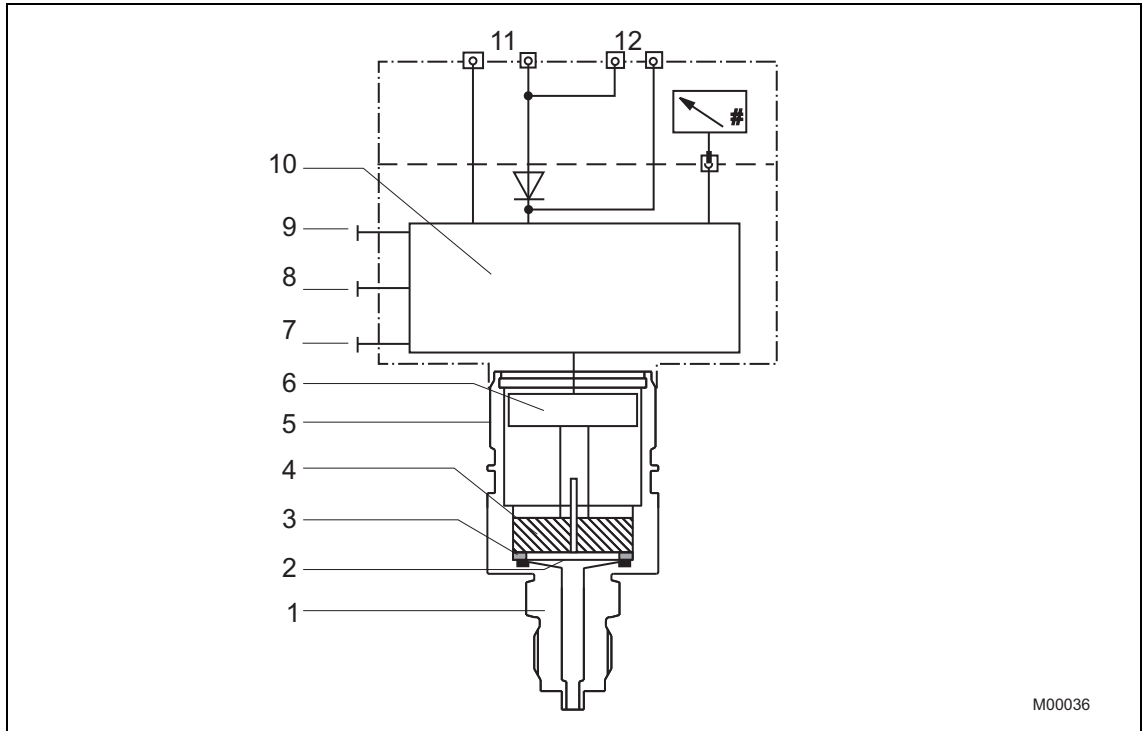

Fig. 5 : 265A transmitter for absolute pressure (in this diagram, measuring ranges ≤ 400 mbar abs.)

- | | |
|--------------------------|--|
| 1 Process connection | 7 Write protection |
| 2 Measuring diaphragm | 8 Span |
| 3 O-ring | 9 Lower range limit value |
| 4 Measuring capsule | 10 Microprocessor-controlled electronics |
| 5 Measuring equipment | 11 Output / Supply power |
| 6 Adjustment electronics | 12 Test instrument |

With HART devices, the 4 ... 20 mA output signal can be tested at the "TEST" terminals without interrupting the signal circuit (this does not apply to fieldbus devices).

Use an ammeter with an internal resistance of $< 10 \Omega$ for this purpose. Switch the measuring device directly into the output circuit for the purpose of configuring or calibrating the transmitter (measuring the current).

It is possible to attach a tag in order to indicate the measuring points.

The "lower range limit value" and "upper range limit value" parameters can be set using "local" buttons on the pressure transmitter. If required, these buttons can be locked using the write protection switch.

The pressure transmitter may be equipped with an LCD display that can be read from the front (optional, can also be retrofitted). The most important transmitter functions and data can be externally parameterized and configured using the "local" control unit in conjunction with this LCD display (see the section "Configuration").

4 Mounting

4.1 General

Before installing the transmitter, check whether the device design meets the requirements of the measuring point from a measurement technology and safety point of view. This applies in respect of the:

- Measuring range
- Gauge pressure stability
- Temperature
- Explosion protection
- Operating voltage

The suitability of the materials must be checked as regards their resistance to the media. This applies in respect of the:

- Seal
- Process connection, separation diaphragm, etc.

In addition, the relevant directives, regulations, standards, and accident prevention regulations must be observed (e.g., VDE/VDI 3512, DIN 19210, VBG, Elex V, etc.).

Measurement accuracy is largely dependent on correct installation of the pressure transmitter and, if applicable, the associated impulse line(s). As far as possible, the measuring setup should be free from critical ambient conditions such as large variations in temperature, vibrations, or shocks.



IMPORTANT (NOTE)

If unfavorable ambient conditions cannot be avoided for reasons relating to building structure, measurement technology, or other issues, the measurement quality may be affected. (See "Specifications").

If a remote seal with capillary tube is installed on the transmitter, the additional operating instructions for remote seals and the related data sheets must be observed.

4.2 IP designation

The housings for 265 .. / 267 .. / 269 .. transmitters have been tested for conformity to IP 67 degree of protection in accordance with the IEC 60529 standard.

The first number indicates the type of protection the integrated electronics have against the ingress of foreign bodies, including dust. "6" means that the housing is dust-proof (i.e., no ingress of dust). The second number indicates the type of protection the integrated electronics have against the ingress of water. "6" means that the housing is protected against water; specifically, powerful jets of water under standardized conditions. "7" means that the housing is protected against water; specifically, against the effects of temporary immersion in water under standardized water pressure and temporal conditions.

4.3 Pressure transmitter

The pressure transmitter can be mounted directly on the shut-off valves. A mounting bracket for wall or pipe mounting (2" pipe) is also available as an accessory.

Ideally, the pressure transmitter should be mounted in a vertical position to prevent subsequent zero position shifts.



IMPORTANT (NOTE)

If the pressure transmitter is installed at an angle, depending on the measuring range the filling liquid exerts hydrostatic pressure on the measuring diaphragm, resulting in a zero position shift. In such an event, the zero position will need to be corrected.

However, generally speaking the pressure transmitter can be used in any mounting position. It is mounted by following the same guidelines as for a manometer.

For mounting options with a bracket, see the section "Technical data".

4.4 Sealing and screw connections

Connecting G ½ B spigot:

For sealing, a flat gasket must be used in accordance with DIN EN 837-1.

NPT threaded connection:

Seal the threads with Teflon or another approved resistant sealant.

Process connection with front-bonded diaphragm:

Prior to mounting the device, install a welded connection or tapped hole according to relevant soldering standards (for process connection and welded connection dimensions, see "Technical data").

Process connection for ball valve:

An appropriate ball valve connection or weld-in sleeve is required for mounting purposes. In this case, the seal is formed by a cone at the outer end of the process connection (metal/metal). For information on the weld-in sleeve, see the section "Technical data".

4.5 Moisture

Use suitable cables and tighten cable glands securely. The transmitter can also be protected against the ingress of moisture by routing the connecting cable downward before securing it. This allows rain and condensation to drip down. This is especially important for installation in outdoor areas and rooms that are exposed to moisture (e.g., due to cleaning processes) or on cooled or heated tanks.

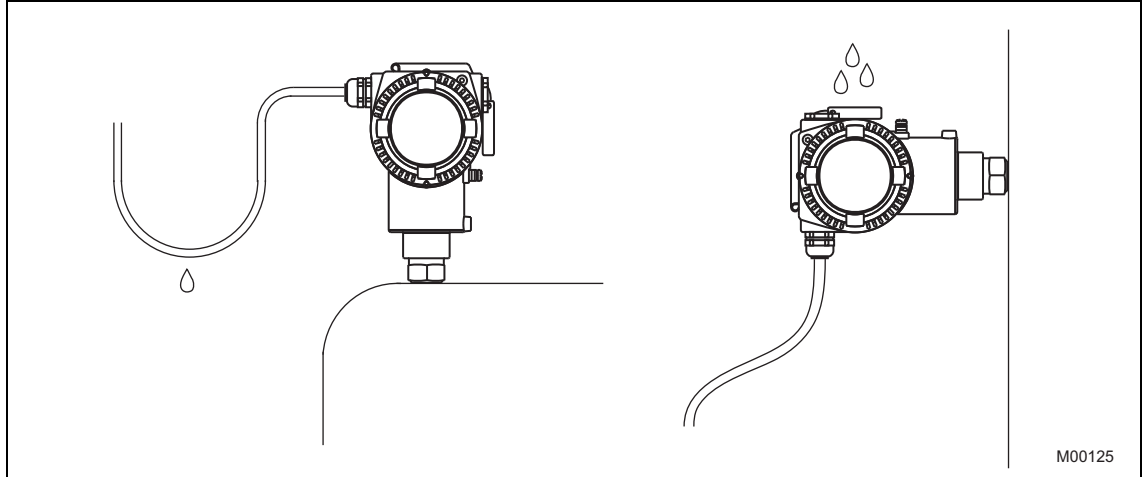

Fig. 6: Steps for preventing the ingress of moisture

4.6 Impulse line

In order for the pipes to be laid correctly, the following points must be observed:

- Keep the impulse line as short as possible and avoid sharp bends.
- Lay the impulse line in such a way that no deposits can accumulate in it. Gradients should not be less than approx. 8 % (ascending or descending).
- The impulse line should be blown through with compressed air or, better yet, flushed through with the measuring medium before connection.
- Completely vent the impulse line if the medium is a fluid.
- Lay the impulse line in such a way that gas bubbles (when measuring fluids) or condensate (when measuring gases) can flow back into the process line.
- When measuring steam, lay the impulse line in such a way that hot steam cannot flow back into the process connection (water trap, e.g., a water trap pipe that is filled with water before installation).
- Check the tightness of the connection.

5 Electrical connections



WARNING - General risks

Observe the applicable regulations governing electrical installation. Connections must only be established in a dead-voltage state. Since the transmitter has no switch-off elements, overvoltage protection devices, lightning protection, and voltage separation capacity must be provided at the plant (overvoltage / lightning protection is optional).

Check that the existing operating voltage corresponds to the voltage indicated on the name plate.

The same lines are used for both the supply power and output signal.

5.1 Cable connection

Depending on the design supplied, the electrical connection is established via a cable entry, M20 x 1.5 or 1/2-14 NPT thread, or Han 8D (8U) plug (PROFIBUS PA and FOUNDATION Fieldbus: M12 x 1 or 7/8" plug).

The screw terminals are suitable for wire cross sections of up to 2.5 mm² (AWG 14).



IMPORTANT (NOTE)

With Category 3 transmitters for use in "Zone 2", the cable gland must be installed by the customer (see the section "Use in explosion-proof areas"). An M20 x 1.5 thread is located in the electronics housing for this purpose.

For pressure transmitters with type of protection "flameproof enclosure" (Ex d), the housing cover must be secured using the locking screw (**Fig. 7**).

For pressure transmitters that conform to the "Canadian Standards Association (CSA) Explosion-Proof" type of design, the following should be noted when establishing an electrical connection via a cable conduit:

The cable conduit must be screwed in using a suitable sealing medium in order to ensure the applicable type of protection (type 4X, IP 67). The screw plug that is already screwed in must be sealed at the plant using Molykote DX. The installer assumes responsibility for any other type of sealing medium used.

At this point, we wish to draw your attention to the fact that increased force will be required to unscrew the housing cover after an interval of several weeks. This is not caused by the threads, but instead is due solely to the type of seal.

5.2 Electrical connection in the cable connection area

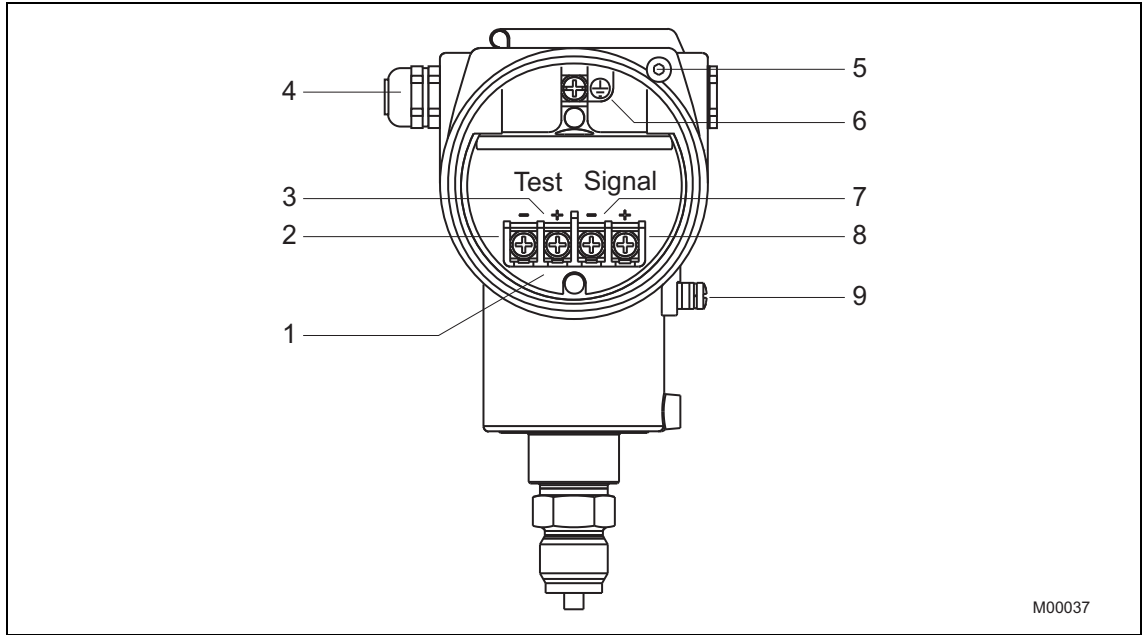

Fig. 7: Cable connection area

- | | |
|--|---|
| <ul style="list-style-type: none"> 1 Screw terminals for 0.5 ... 2.5 mm²-
(AWG 20 ... AWG 14) wire 2 Test terminals for 4 ... 20 mA (not with
Fieldbus transmitters) 3 Test 4 Cable entry (e.g., via M20 x 1.5) | <ul style="list-style-type: none"> 5 Ex d locking screw 6 Grounding/equipotential bonding terminal 7 Signal 8 Output signal/operating voltage 9 Grounding/equipotential bonding terminal |
|--|---|

The electrical connection is established in the connection area. The housing cover must be unscrewed for this purpose.

The M20 x 1.5 cable glands, which are supplied by the manufacturer, are screwed only loosely into the electronics housing. In order to achieve protection type IP 67, the glands must be screwed in using a suitable tool (hexagon head, SW 22) until they are hand-tight.

Delivery scope

HART devices	Gland/mating plug
M20 x 1.5 cable entry	Plastic cable gland (6 ... 12 mm clamping area)
1/2 - 14 NPT	Not included in delivery scope
Han 8D (8U) device plug	Socket connector

Bus devices (PA/FF)	Gland/mating plug
M20 x 1.5 cable entry	Metal cable gland (6 ... 12 mm clamping area)
1/2 - 14 NPT	Not included in delivery scope
M12 x 1 connector	Not included in delivery scope
7/8" connector	Not included in delivery scope

Terminal assignment

Terminals	Description
Signal (+) and (-)	Operating voltage
Test (+) and (-)	Test terminals for 4 ... 20 mA (HART); not available with fieldbus transmitters

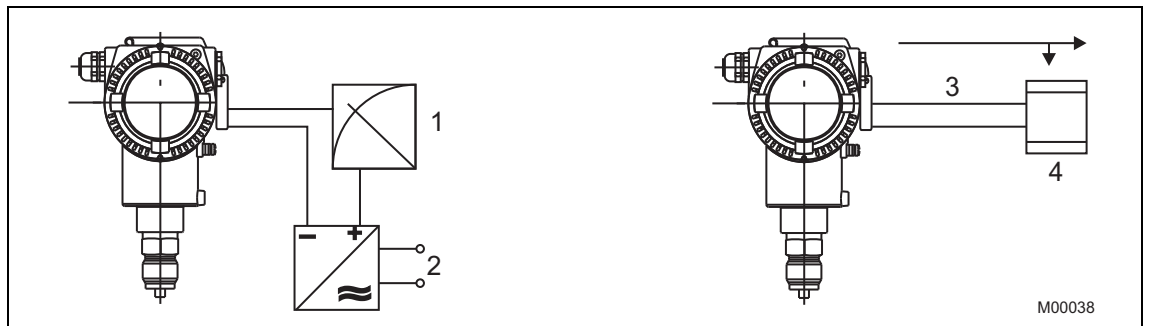

Fig. 8: Connection diagram, left: 4 ... 20 mA current output with HART communication protocol and supply power; right: PROFIBUS PA or FOUNDATION Fieldbus

- 1 E.g., ammeter in 4 ... 20 mA circuit
- 2 Supply power / Power supply unit:
Non-Ex applications: 10.5 (14) ... 45 V
Ex applications ¹⁾: 10.5 (14) ... max. 30 V (intrinsically safe)
- 3 PROFIBUS PA or FOUNDATION Fieldbus
- 4 PROFIBUS PA:
Connection to PLC or PC via segment coupler
FOUNDATION Fieldbus:
Connection to PLC or PC via FF supply unit

¹⁾ Important: If, when using transmitters with type of protection "intrinsic safety", an ammeter is connected to the output circuit or a modem is connected in parallel while there is a risk of explosion, the sums of the capacitances and inductances of all circuits, including the transmitter (see EC-type-examination certificate) must be equal to or less than the permissible capacitances and inductances of the intrinsically safe signal circuit (see EC-type-examination certificate for the supply unit). Only passive or explosion-proof devices or indicators may be connected.

5.3 Electrical connection with plug



Fig. 9: Fieldbus connector

Pin assignment		
Pin number	FOUNDATION Fieldbus	PROFIBUS PA
1	FF-	PA+
2	FF+	-
3	Shield	PA-
4	-	Shield

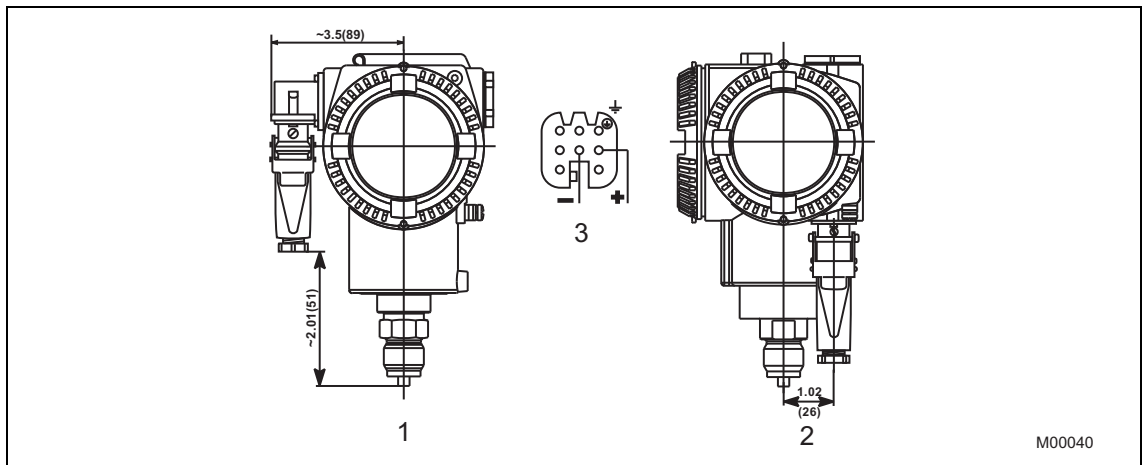

Fig. 10: (HART) Han 8D (8U) plug connector

- 1 Barrel type
- 2 DIN type

- 3 Socket insert (view of sockets)

5.4 Assembling and connecting the socket connector

The socket connector for connecting the cable is supplied unassembled as an accessory for the transmitter.



IMPORTANT (NOTE)

Please observe the specifications for the electrical connection that have been supplied with the connector.

Assembly is depicted in the figure below.

1. The contacts (2) are crimped or soldered onto the cable ends (wire cross-section of 0.75 ... 1 mm² (AWG 18 ... AWG 17)), from which approx. 1.5 ... 2 cm (0.59 ... 0.79 inch) of the sleeve and approx. 8 mm (0.32 inch) of the insulation have been stripped; they are then inserted into the socket (1) from the rear.
2. Slide the set screw (6), clamping ring (5), gasket (4), and housing (3) onto the cable in the order indicated before assembly (you may have to adjust the gasket (4) to fit the cable diameter).



IMPORTANT (NOTE)

Before you press the contacts completely into the socket, check the connection points again. Incorrectly inserted contacts can be removed by using a press-out tool (part no.: 0949 813), or a standard ballpoint pen as a makeshift tool.

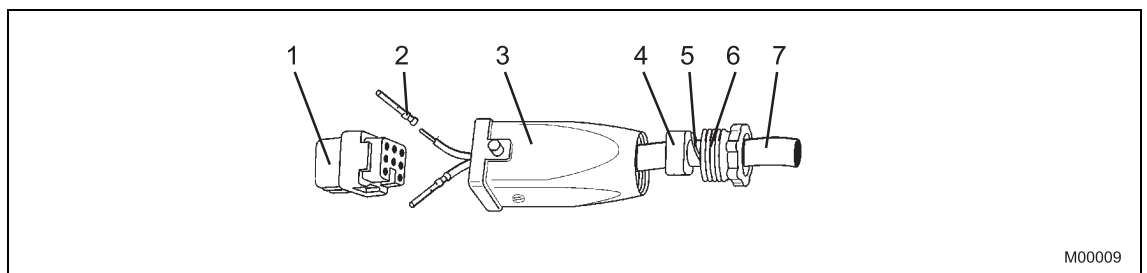

Fig. 11: Assembly of Han 8D (8U) socket connector

- | | |
|-----------------------|--|
| 1 Socket | 5 Clamping ring |
| 2 Contact | 6 PG 11 set screw |
| 3 Housing | 7 Cable (diameter 5 ... 11 mm
(0.20 ... 0.43 inch)) |
| 4 Gasket (can be cut) | |

Grounding

A terminal is available on both the outside of the housing and in the plug for grounding (PE) the transmitter. Both terminals are electrically connected to one another.

5.5 Protective conductor / Grounding

The transmitter operates within the specified levels of accuracy for common-mode voltages of up to 250 V between signal lines and housings.

As a general rule, the transmitter must be supplied by a voltage source with a maximum output voltage of 60 V DC, which is safely isolated from the line supply. To ensure that the safety objectives of the Low Voltage Directive are achieved, and the corresponding EN 61010 regulations governing installation of electrical equipment are observed, the housing must have a protective system (e.g., grounding, protective conductor) that is activated if voltages > 60 V DC occur.

5.6 Integrated lightning protection (optional)

The transmitter housing must be connected using the grounding terminal (PA), by means of a short connection with the equipotential bonding. Equipotential bonding (minimum diameter: 4 mm² (AWG 12)) is required throughout the cable routing area.

In the case of transmitters with integrated lightning protection (optional), the intrinsically safe circuit is connected to the equipotential bonding for safety reasons.



IMPORTANT (NOTE)

Test voltage withstand capability can no longer be ensured when this protective circuit is used.

5.7 Communication setup

(4 ... 20 mA; HART protocol)

The transmitter can be operated via a modem, using a PC or laptop. The modem can be connected to the transmitter in parallel at any point in the signal circuit. Communication between the transmitter and modem occurs via AC signals that are superimposed on the analog 4 ... 20 mA output signal. This modulation occurs without averaging and does not, therefore, affect the measuring signal.

Communication between the transmitter and PC or laptop is only possible if the signal circuit is set up as shown in Fig. 12. The resistance between the connection point for the FSK modem and the supply unit must be at least 250 Ω (including internal resistance of the supply unit). If this value is not achieved within the context of normal installation, an additional resistor must be used.

In the case of supply modules with HART communication, the additional resistor is often installed permanently by the manufacturer. Some of these modules offer the option of communicating directly over the supply module in the operating mode "FSK bus".

Power can be supplied by supply units, batteries, or power supplies; these must be designed to ensure that the operating voltage U_B of the transmitter always remains between 10.5 V DC and 45 V DC (for LCD displays with backlighting: 14 ... 45 V DC).

In addition, the maximum current of 20 ... 22.5 mA resulting from overranging must be considered, depending on the corresponding parameterization. This yields the minimum value for U_S . If additional signal receivers (e.g., displays) are looped into the signal circuit, their resistance must also be considered.

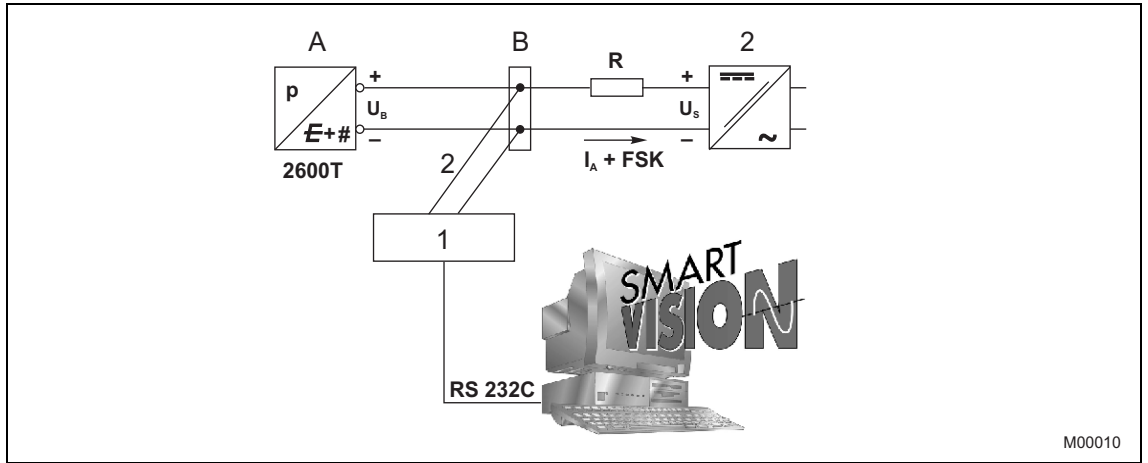

Fig. 12: Communication mode: Point-to-point

- A Pressure transmitter
- 1 FSK modem
- 2 Supply unit
- 2 Possible connection points for a modem between A and B

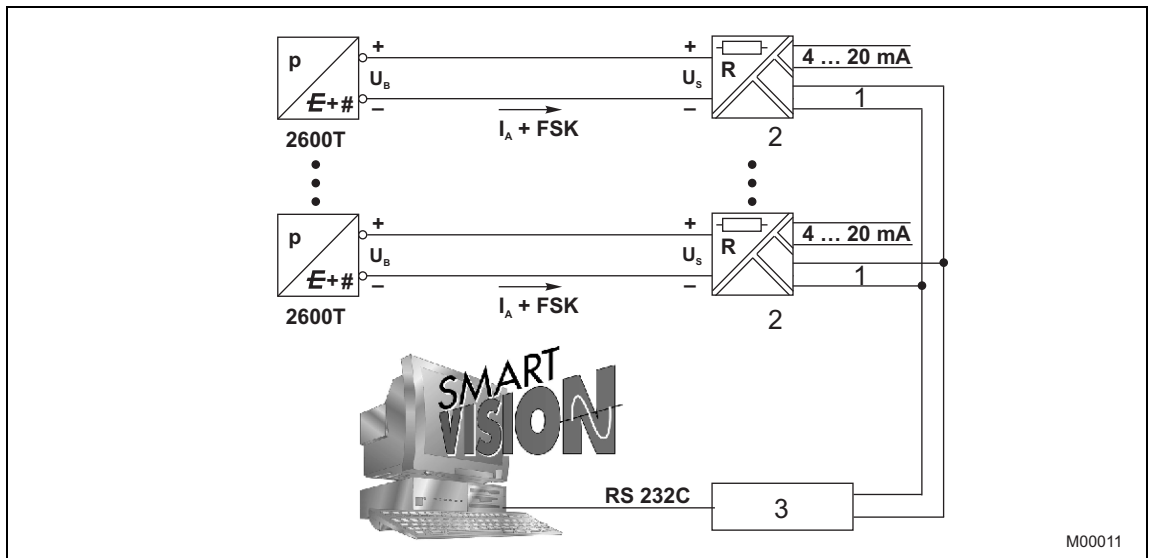

Fig. 13: Communication mode: FSK bus

- 1 FSK bus
- 2 Supply module with HART isolation
- 3 FSK modem

5.8 Connecting cable

Communication between the transmitter and PC or laptop is only possible if the cabling meets the following requirements:

It is recommended that shielded, twisted pair cables are used.

The minimum wire diameter depends on the line length.

Line lengths up to 1,500 m (4,921 ft): 0.51 mm (0.02 inch)

Line lengths above 1,500 m (4,921 ft): 0.81 mm (0.03 inch)

The maximum line length is limited.

Dual-core cable: 3,000 m (9,842 ft)

Multi-core cable: 1,500 m (4,921 ft)

The actual possible line length of the electrical circuit depends on the total capacitance and resistance, and can be estimated using the following formula:

$$L = \frac{65 \times 10^6}{R \times C} - \frac{C_f + 10000}{C}$$

L = Line length in meters

R = Total resistance in Ω (ohms)

C = Line capacitance in pF/m

C_f = Maximum internal capacitance of the HART field devices located in the circuit, in pF

Avoid routing cables with other electrical cables (with inductive load, etc.) or near large electrical equipment.



IMPORTANT (NOTE)

The shielding for the connecting cable should only be grounded at one side.

5.9 PROFIBUS PA pressure transmitter

PROFIBUS PA transmitters are designed to be connected to the DP / PA segment coupler / linking device. The permissible terminal voltage is within the range of 10.2 ... 32 VDC.

Use of a shielded cable is recommended. The shielding is bonded by means of the metal cable gland.



IMPORTANT (NOTE)

The transmitter must be grounded.

The switch-on behavior corresponds to Draft DIN IEC 65C/155/CDV of June 1996. If the transmitter is operated on an Ex segment coupler / linking device in accordance with DIN EN 61 158-2 of October 1994, time-dependent current limiting may cause the maximum number of devices to be reduced.

The "OUT" variable is transmitted cyclically. This consists of the output value and 1 byte of status information. The output value is transmitted with 4 bytes as an IEEE 754 floating-point type.

For additional information on PROFIBUS PA - including the subject "Identification numbers" - please refer to "Additional notes 41/15-110" and the data sheet "Installation suggestions 10/63-0.40". These can be obtained from the Internet site www.abb.com; additional information is also available at www.profibus.com.

6 Commissioning

Once the pressure transmitter has been installed, it is put into operation by switching on the operating voltage.

Check the following before switching on the operating voltage:

- Process connections
- Electrical connection
- The impulse line and measuring chamber of the measuring equipment must be completely filled with the measuring medium.

The transmitter can then be put into operation. To do this, the shut-off valves must be actuated in the following order (in the default setting, all valves are closed):

1. Open the discharge shut-off valve, if present.
2. Open the shut-off valve.

To put the transmitter out of operation, carry out the steps in reverse order.

i

IMPORTANT (NOTE)

In the case of the pressure transmitter for absolute pressure with measuring ranges of ≤ 40 kPa absolute, please be aware that the measuring equipment will have been overloaded by the atmospheric pressure due to the long periods of transport and storage involved. For this reason, you will need to allow a starting time of approx. 3 hours after commissioning, until the sensor has stabilized to such an extent that the specified accuracy can be maintained.

If, when using "intrinsically safe" transmitters, an ammeter is connected to the output circuit or a modem is connected in parallel while there is a risk of explosion, the sums of the capacitances and inductances of all circuits, including the transmitter (see EC-type-examination certificate) must be equal to or less than the permissible capacitances and inductances of the intrinsically safe signal circuit (see EC-type-examination certificate for the supply unit). Only passive or explosion-proof devices or indicators may be connected.

If the output signal stabilizes only slowly, it is likely that a large damping time constant has been set on the transmitter.

6.1 Output signal

If the applied pressure is within the values indicated on the name plate, the output current ranges between 4 and 20 mA.

If the pressure applied falls outside the set range, the output current will be between 3.5 mA and 4 mA if the range is undershot or between 20 mA and 22.5 mA if the range is overshoot (depending on the respective configuration).

Standard setting for normal operation

3.8 mA/20.5 mA

A current that is < 4 mA or > 20 mA may also indicate that the microprocessor has detected an internal error.

Standard setting for error detection

21 mA

The graphical user interface (DTM) can be used to diagnose the error.



IMPORTANT (NOTE)

A brief interruption in the power supply results in initialization of the electronics (program restarts).

6.2 Write protection

Write protection prevents the configuration data from being overwritten by unauthorized users. If write protection is enabled, the "0 %" and "100 %" buttons are disabled.

However, it is still possible to read out the configuration data using the graphical user interface (DTM) or another, similar communication tool.

The control unit may be leaded if required.

Write protection is activated as follows (also refer to the symbols on the plate):

1. First, use a suitable screwdriver to press the switch down fully.
2. Then turn the switch clockwise by 90°.



IMPORTANT (NOTE)

To deactivate the switch, push it down slightly and then turn counterclockwise by 90°.

6.3 Correcting the lower range value / zero shift

During installation of the transmitter, zero position shifts caused by the mounting position (e.g., a slightly oblique mounting position due to a remote seal, etc.) may occur; these must be corrected.



IMPORTANT (NOTE)

The transmitter must have reached its operating temperature (approx. 5 min. after startup, if the transmitter has already reached the ambient temperature) in order to perform zero position shift correction. The correction must be made at $p_e = 0$ or, for absolute pressure equipment, at $p_{abs} = \text{absolute } 0$.

There are two options (point A or B) for correcting the 4 ... 20 mA output signal directly on the pressure transmitter:



IMPORTANT (NOTE)

The button unit must be available for this purpose. Operating the buttons using a magnetic screwdriver is not permitted.

A. Set lower range limit value

1. Apply lower range limit value pressure (4 mA) from the process or from a pressure generator. The pressure must be stable and applied with a high level of accuracy $\ll 0.05\%$ (observing the set damping value).
2. Press the "0 %" button on the pressure transmitter. The output signal is set to 4 mA. The span remains unchanged.



IMPORTANT (NOTE)

A lower range limit value set using this method will be stored in the non-volatile memory < 25 s (HART), < 110 s (PROFIBUS PA), and < 15 s (FOUNDATION Fieldbus) when the "0 %" button is pressed for the final time.

B. Correct the zero shift

1. Use the LCD display (installed as an option) to call up the "SHIFTZERO" menu item using the pushbuttons "M" and "+".
2. The correction is made by pressing the "M" button (refer to the section "Configuration with the LCD display").
3. Put the pressure transmitter into operation as described at the beginning of this section.



IMPORTANT (NOTE)

The procedure described in "A" above does not affect the physical pressure shown; it only corrects the analog output signal. For this reason, the analog output signal may differ from the physical pressure shown on the digital display or the communication tool.

To avoid this discrepancy, correct the zero position shift (zero shift) via the graphical user interface (DTM).

Menu path: „Configure Pressure Measurement_Process Variable"

However, the lower range limit value must not have been corrected already using the "0 %" button.

6.4 Turning the housing in relation to the measuring equipment

The electronics housing can be rotated 360° and fixed in any position; a stop is provided to prevent it from rotating past this point.

- To activate this, slacken the housing stop screw on the neck of the housing (hex-head socket screw SW 2.5) by approx. 1 rotation (do not pull it out) and, once the desired position has been reached, retighten it until hand-tight.

6.5 Installing / Removing the button unit

1. Slacken the screw on the protective cap and move the cap to one side.
2. Using a suitable screwdriver, for example, push the lock bar all the way out of the button unit.
3. This releases the square nut; remove this from the button unit.
4. Use a Torx screwdriver (size T10) to slacken the fixing screw for the button unit, and then remove the unit from the electronics housing.
5. If necessary, insert a filler piece and secure it using the screw supplied.

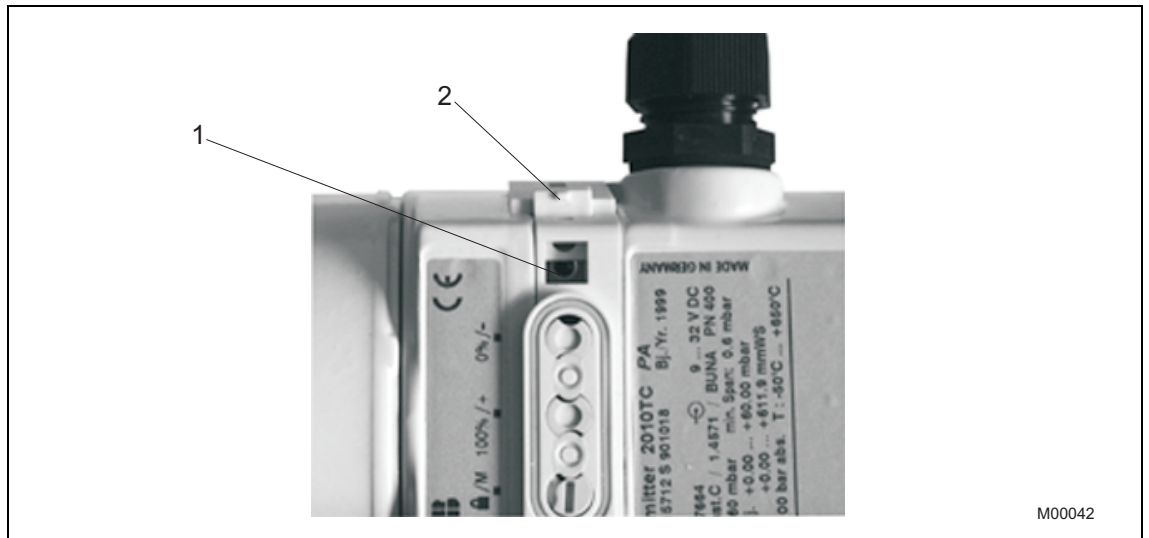

Fig. 14: Installing/removing the button unit

1 Fixing screw

2 Lock bar



IMPORTANT (NOTE)

The fixing screw is located underneath the button unit.

6.6 Installing / Removing the LCD display

1. Unscrew the housing cover of the electronics area (refer to the figure "Securing the housing cover" in the next section).



IMPORTANT (NOTE)

The optional LCD indicator is designed with type of protection "intrinsic safety" and has been included for the purpose of the transmitter's EC type-examination certificate.

With an Ex d design, please refer to the section titled "Securing the housing cover with Ex d".

2. Attach the LCD display. Depending on the mounting position of the pressure transmitter, the LCD display may be attached in four different positions. This enables $\pm 90^\circ$ or $\pm 180^\circ$ rotations.



IMPORTANT (NOTE)

In the case of LCD displays with backlighting (optional), a 3-wire cable with a plug is located at the rear of the LCD display. Connect this plug to the 3-pin terminal in the electronics area before attaching the display (see Fig. 15).

3. If the 3-pin terminal strip is equipped with a jumper (fieldbus transmitters do not have jumpers), remove this and insert it in the "jumper holder".
4. Screw the LCD display in place using the two screws.
5. Retighten the housing cover screws until they are hand-tight.



IMPORTANT (NOTE)

If necessary, refer to the section titled "Securing the housing cover with Ex d".

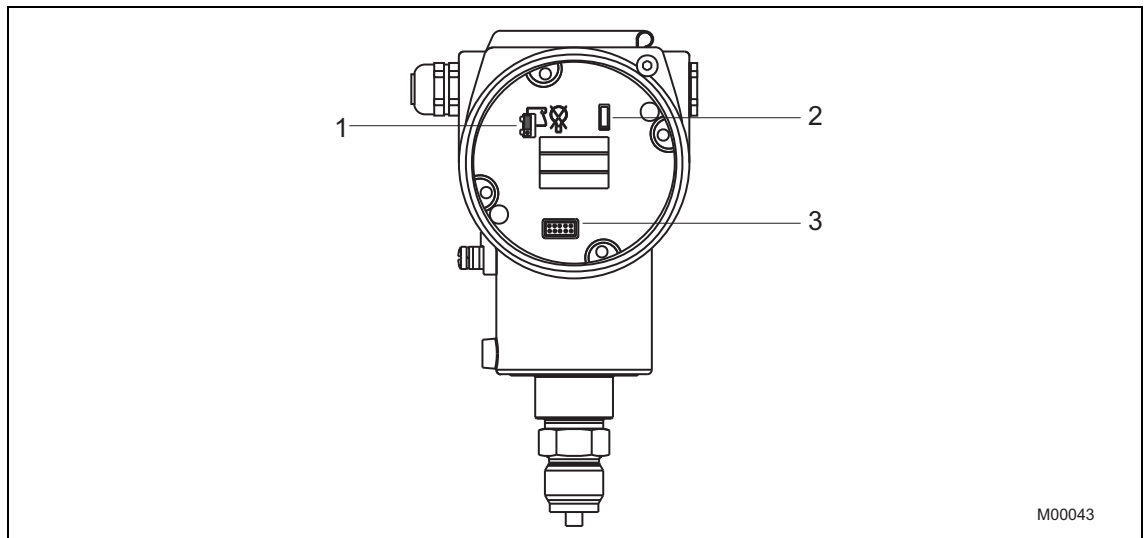

Fig. 15: Electronics area - Installing the LCD display

- | | | | |
|---|--|---|---|
| 1 | Position of the jumper or cable connector for an LCD display with backlighting | 3 | 10-pin terminal strip for the LCD display |
| 2 | Jumper holder for an LCD display with backlighting | | |



Note for 1

The jumper must be present if the backlighting option has not been selected for the LCD display.

6.7 Securing the housing cover with Ex d

Each of the front faces of the electronics housing features a locking screw (hex-head socket screw SW 3) on the top right-hand side.

1. Attach the housing cover to the housing by hand-tightening the screws.
2. Turn the locking screw counterclockwise to secure the housing cover. This involves unscrewing the screw until the screw head stops at the housing cover.

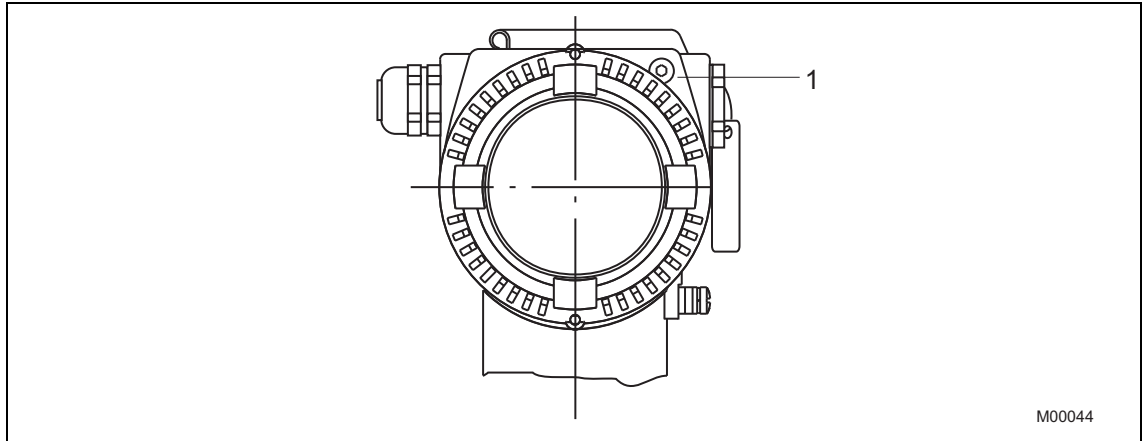

Fig. 16: Securing the housing cover

- 1 Locking screw

6.8 Sensor ventilation

For technical reasons, you must apply atmospheric pressure to the reference side of the pressure sensor.

An external ventilation opening, which is protected by a PTFE filter, is provided on the measuring equipment for this purpose. You should, however, make sure that this ventilation opening is not covered (e.g., do not paint over it or apply oil containing silicone).



IMPORTANT (NOTE)

Covering the ventilation opening will result in inaccurate measurements.



Fig. 17

- 1 Ventilation opening (in this diagram, measuring ranges ≥ 2.5 bar)

6.9 Operation

6.9.1 Operation using the control buttons on the transmitter

The control unit on the transmitter consists of 2 pushbuttons for setting the "Lower Range Value" (0 %) and "Upper Range Value" (100 %) parameters, as well as a write protection switch.



IMPORTANT (NOTE)

No housing entries are required for the pushbuttons or switch.

To access the pushbuttons, the screw must be slackened and the protective cap moved to one side (see Fig. 18).

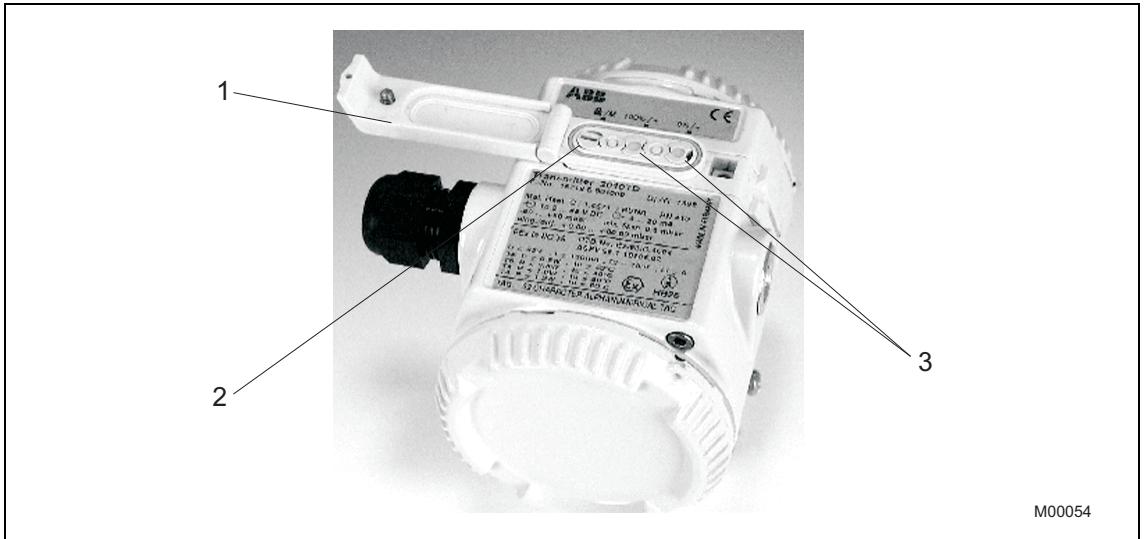

Fig. 18: Operating elements

- 1 Protective cap
- 2 Mode pushbutton (M)
- 3 Control buttons

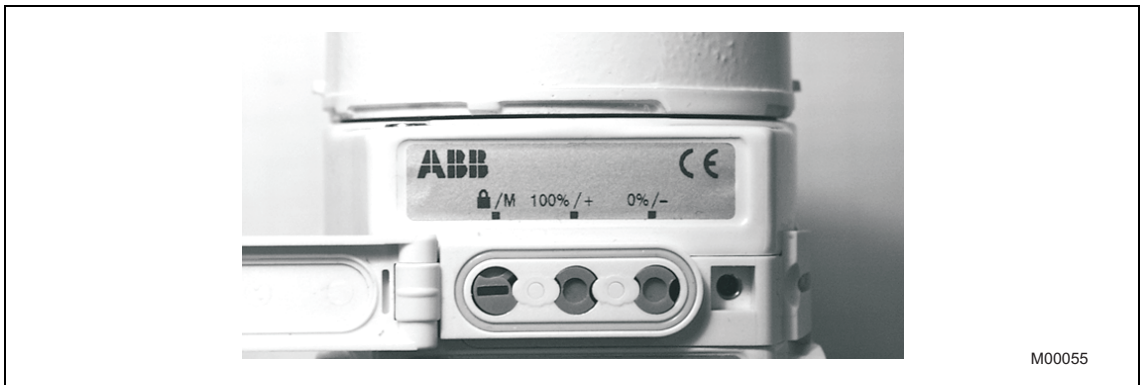

Fig. 19: Plate with button legend, etc.



NOTICE - Potential damage to parts!

Operating the control buttons with a magnetic screwdriver is not permitted.

7 Configuration



WARNING - Potential property damage as a result of electrostatic charging!

There is no protection against accidental contact when the housing cover is open. Do not touch conductive parts.

7.1 Factory settings

Transmitters are calibrated at the factory to the customer's specified measuring range. The calibrated range and measuring point number are provided on the name plate. If this data has not been specified, the transmitter will be delivered with the following configuration:

7.1.1 Transmitter with HART communication and 4 ... 20 mA output current

Parameter	Factory settings
4 mA	Zero position
20 mA	Measuring range upper limit (URL)
Output	Linear
Damping	0.125 s
Transmitter failure mode	21 mA
Optional LCD display	0 ... 100 %, linear

Any or all of the configurable parameters listed above - including the "Lower Range Value" and "Upper Range Value" - can easily be changed using a portable HART handheld terminal or the PC operation software SMART VISION with DTM for 2600T. Data regarding flange type and material, O-ring materials, and type of filling liquid is stored in the device.

7.1.2 Transmitter with PROFIBUS PA communication

Parameter	Factory settings
Measuring profile	Pressure
Physical unit	mbar/bar
Output scale 0%	Measuring range lower limit (LRL)
Output scale 100%	Measuring range upper limit (URL)
Output	Linear
Upper alarm limit	Measuring range upper limit (URL)
Upper warning limit	Measuring range upper limit (URL)
Lower warning limit	Measuring range lower limit (LRL)
Lower alarm limit	Measuring range lower limit (LRL)
Hysteresis limit value	0.5 % of output scaling
PV filter	0.125 s
Address	126

Any or all of the configurable parameters listed above - including the “Lower Range Value” and “Upper Range Value” - can easily be changed using the PC operation software SMART VISION with DTM for 2600T. Data regarding flange type and material, O-ring materials, and type of filling liquid is stored in the device.

7.1.3 Transmitter with FOUNDATION Fieldbus communication

Parameter	Factory settings
Measuring profile	Pressure
Physical unit	mbar/bar
Output scale 0%	Measuring range lower limit (LRL)
Output scale 100%	Measuring range upper limit (URL)
Output	Linear
Upper alarm limit	Measuring range upper limit (URL)
Upper warning limit	Measuring range upper limit (URL)
Lower warning limit	Measuring range lower limit (LRL)
Lower alarm limit	Measuring range lower limit (LRL)
Hysteresis limit value	0.5 % of output scaling
PV filter	0.125 s
Address	Not required

Any or all of the configurable parameters listed above - including the “Lower Range Value” and “Upper Range Value” - can be changed using any FOUNDATION Fieldbus-compatible configuration tool. Data regarding flange type and material, O-ring materials, and type of filling liquid is stored in the device.

7.2 Configuration types

Pressure transmitters can be configured as follows:

- Configuration of the parameters for the “Lower Range Value” and “Upper Range Value”, without an LCD display
- Configuration of the pressure transmitter using the LCD display (menu-controlled)
- Configuration with a handheld terminal
- Configuration using a PC/laptop via the graphical user interface (DTM)

7.3 Configuring the parameters without an LCD display

The "Lower Range Value" and "Process Variable" parameters can be set directly on the transmitter using the buttons. The transmitter has been calibrated by the manufacturer based on the order information. The name plate contains information on the "Lower Range Value" and "Upper Range Value" set.

In general, the following applies:

The 1st pressure value (e.g., 0 mbar) is always assigned to the 4 mA signal, while the 2nd pressure value (e.g., 400 mbar) is always assigned to the 20 mA signal.

To reset the transmitter, apply the pressure for the "lower range value" and "upper range value" to the measuring equipment. Make sure that the measuring limits are not exceeded.



IMPORTANT (NOTE)

Reducing stations with adjustable pressure and reference displays can be used as pressure generators.

When making the connection, please ensure that there are no residual fluids (for gaseous testing materials) or air bubbles (for fluid testing materials) in the connection lines, since these can lead to errors during inspection.

Any potential measuring error for the pressure generator should be at least three times smaller than the desired measuring error for the transmitter.

It is recommended that the damping is set to zero using the button and LCD display, or the graphical user interface (DTM). The set time constant must be known for this purpose.



IMPORTANT (NOTE)

In the case of the 265A transmitter for absolute pressure with measuring ranges of ≤ 400 mbar abs., please be aware that the measuring equipment will have been overloaded by the atmospheric pressure due to the long periods of transport and storage involved. For this reason, you will need to allow a starting time of approx. 3 hours after commissioning, until the sensor has stabilized to such an extent that the specified accuracy can be maintained.

Configuring the parameters

1. Apply the pressure for the "Lower Range Value" and wait approx. 30 s until it has stabilized.
2. Press the 0% button. This sets the output current to 4 mA.
3. Apply the pressure for the "Upper Range Value" and wait approx. 30 s until it has stabilized.
4. Press the 100% button. This sets the output current to 20 mA.
5. If required, reset the damping to its original value.
6. Record the new settings. The respective parameter will be stored in the non-volatile memory 10 s after the 0% or 100% button is last pressed.

**NOTICE**

Operating the control buttons with a magnetic screwdriver is not permitted.

**IMPORTANT (NOTE)**

This configuration procedure only changes the 4 ... 20 mA current signal; it does not affect the physical process pressure shown on the digital display or user interface. To avoid potential discrepancies, you can make corrections by following the menu path "Calibrate_Pressure Measurement_Adjust input" in the user interface.

After performing a correction, you must check the device configuration.

7.4 Configuration with the LCD display

The LCD display can be used to configure the transmitter by means of the (-/+/M) buttons, as follows:



NOTICE - Potential damage to parts!

Operating the control buttons with a magnetic screwdriver is not permitted.



IMPORTANT (NOTE)

The information in parentheses refers to the relevant menu item. The menu items are displayed in the 1st and 2nd lines of the LCD display. The full menu structure can be found in the section "Menu structure".

- (EXIT) Exit the menu
- (VIEW) View selected measured values and calculation values
- (GET 0 %) Lower range limit value with applied pressure
- (GET 100 %) Upper range limit value with applied pressure
- (SET 0 %) Lower range limit value without applied pressure
- (SET 100 %) Upper range limit value without applied pressure
- (SHIFTZERO) Correct zero position drift (e.g., zero shift)
- (OFFSET SHIFT) Offset shift
- (OUT 0 %) Scaling of output variable start value
- (OUT 100 %) Scaling of output variable end value
- (DAMPING) Damping
- (ALARM CURRENT) Output current in the event of an error; only available for 4 ... 20 mA devices with HART protocol
- (DISPLAY) Display value
- (UNIT) "p" and "OUT" units
- (FUNCTION) Characteristic
- (ADDRESS) Fieldbus address; only available for devices with PROFIBUS PA or FOUNDATION Fieldbus protocol

The sections that follow contain explanations for some of the menu items listed above.

7.4.1 Offset shift (OFFSET SHIFT)

This function performs an offset shift of the characteristic so that it travels through a point specified by the user. This makes it possible to set the output signal of several measuring devices that measure the same process variable to the same value, without the need to perform calibration with applied pressure.

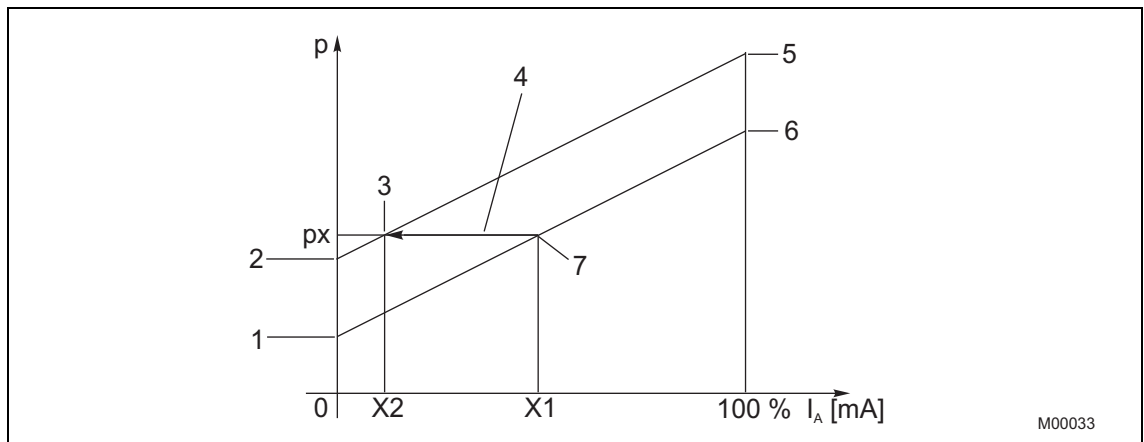

Fig. 20: Offset shift

- | | |
|---------------------|---------------------|
| 1 Old zero position | 5 New end value |
| 2 New zero position | 6 Old end value |
| 3 New balance point | 7 Old balance point |
| 4 Offset shift | |

This function can be performed at any point on the characteristic, provided that the following circumstances apply:

- The process variable is within the set measuring range. The pressure transmitter has a linear transmission characteristic.
- Entering the desired output current as a percentage performs an offset shift for the measuring range.
- When a pressure p_x is applied, the pressure transmitter displays the standardized output value x_1 as a percentage. Based on the current application, however, the value x_2 should be displayed. The value x_2 is now set via the local control unit/LCD. The transmitter calculates the new zero position and the new end value, and adopts these settings (see Fig. 20, Offset shift).

7.4.2 Damping (DAMPING)

When the output signal for the transmitter is noisy as a result of the process, the signal can be smoothed (damped) electrically.

The additional time constant can be set between 0 s and 60 s in increments of 0.001 s.

Damping does not affect the value shown on the digital display as a physical unit. It only affects the parameters derived from this, such as the analog output current, free process variable, input signal for the controller, and so on.

7.4.3 Characteristic (FUNCTION)

This menu item enables you to switch between the "linear" and "freely programmable" functions.

The individual values of the freely programmable characteristic cannot be changed here. A handheld terminal or graphical user interface (DTM) must be used in order to make changes.

7.4.4 Fieldbus address (ADDRESS)

This menu item enables you to change the fieldbus slave address. A number between 0 and 126 must be entered for the selected pressure transmitter.

All new devices receive the factory setting "126". The pressure transmitters should be assigned different addresses; this is the only way to ensure targeted addressing. If, for example, the device data is loaded via the graphical user interface (DTM) after the address has been changed, a new connection will be established and an error message may appear. This error message must be acknowledged with "Repeat". The data will then be loaded without any problems.

7.5 Layout and contents of the LCD display

The display is a 2-line, 7-character, 19-segment alphanumeric display with an additional bar display. As an option, the display can be equipped with backlighting.

7.5.1 Displaying a physical value



Fig. 21

- | | |
|---|--|
| <p>1 Symbol for</p> <ul style="list-style-type: none"> • Transmission function (e.g., linear) • Mode • Status / code | <p>2 Bar for displaying the process value in %</p> <p>3 Current measured value (1st line)</p> <p>4 Unit (2nd line)</p> |
|---|--|

First line

In the first line, the first column indicates the sign, and the next six digits display the measured value amount.

Decimal point display

The position of the decimal point is determined by the unit selected and cannot be changed. The decimal point is positioned so that the maximum value can be displayed with six digits. Decimal points are not displayed at the sixth place. Therefore, a maximum of +/- 999999 can be displayed. If this value is exceeded, "Overflow" is displayed.

Second line

In the second line, the unit is displayed in the last five columns. The first column shows the symbols listed below. If necessary, these symbols can also be displayed one after the other. The symbol displayed is changed in cycles of one second.

Explanation of the symbols

Display for	Symbol	Comment
Transmission function	$/$, $\sqrt{\quad}$, or \int	One of these symbols is always displayed.
Write protection		Only when write protection is set
Cyclic communication	Only with PROFIBUS PA
Status available (e.g., measuring range exceeded or hardware error)		Only when a status is available
Display value code	1 ... 9	Menu display (see the section "Menu structure")
The transmitter is busy.		This symbol overrides other symbols.

Transmission function symbols

Symbol	Description
$/$	Linear
$\sqrt{\quad}$	Square root
\int	Freely programmable characteristic

How the percentage value is shown on the LCD display

Position	Display
1st line	Percentage value, limits: -25 ... 125 %, 2 decimal places
2nd line	1st digit: Transmission function (see previous table) 2nd digit: Write protection (see previous table) 7th digit: %
Bar	2 % increments, from -2 ... 100 %, no hysteresis

7.5.2 Menu structure

The parameters are structured in the form of a menu. The menu consists of a maximum of three levels.

The menu is called up using the mode button "M".

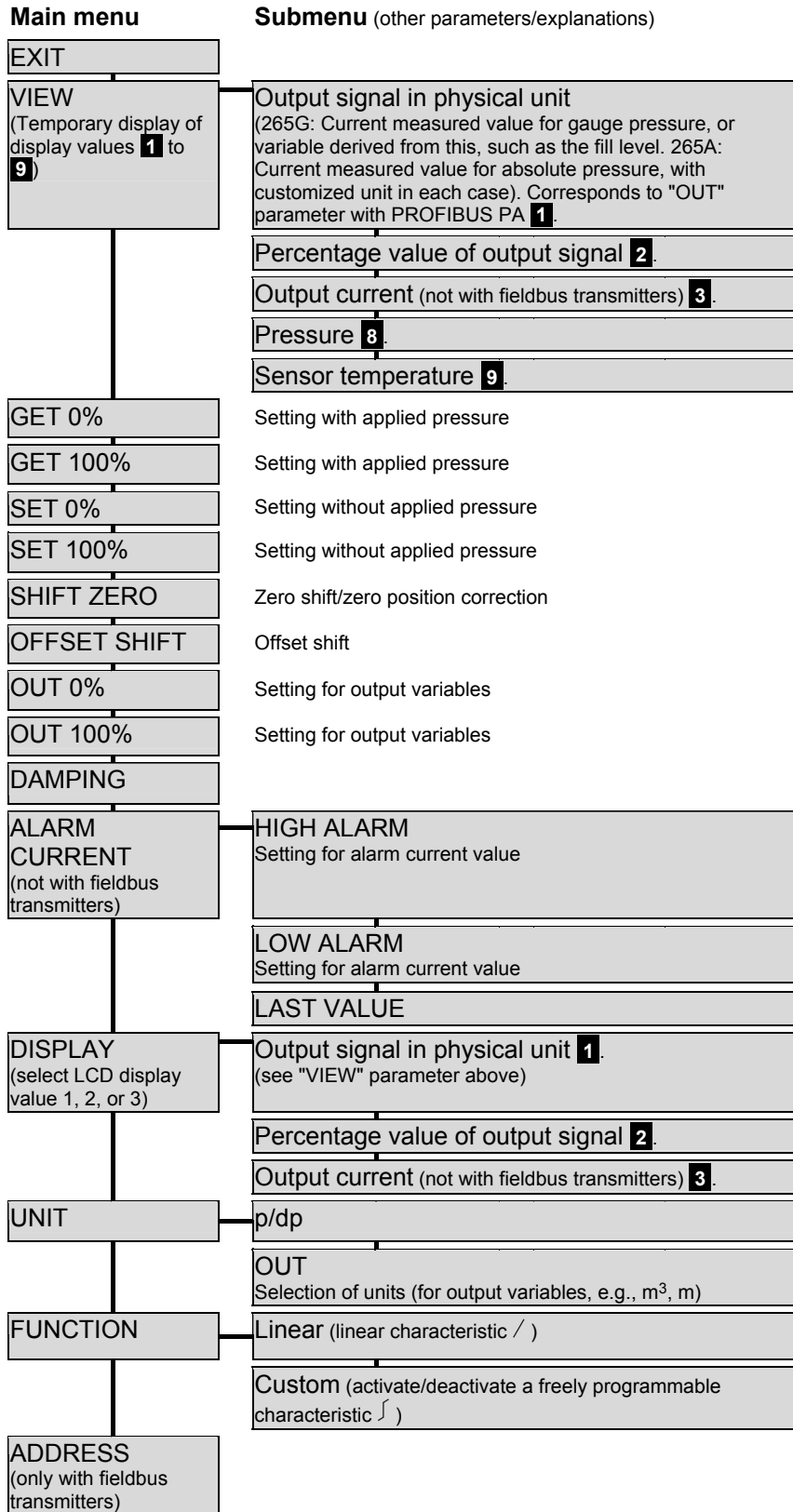

The numbers displayed inversely (**1** to **9**) specify the code for the display value. These numbers are shown on the 2nd line of the display, on the left-hand side.

Units of the parameter
„UNIT -> p/dp“

- Pa
- GPa
- MPa
- KPa
- mPa
- uPa
- HPa
- bar
- mbar
- Torr
- Atm
- Psi
- g/cm²
- kg/ cm²
- in H₂O
- mm H₂O
- ft H₂O
- in Hg
- mm Hg

7.6 Menu-controlled pressure transmitter programming

Function	Description
Start	Menu-controlled programming is started with the mode pushbutton "M".
Next menu item	The next menu item is called up by pressing the "+" pushbutton.
Previous menu item	Press the "-" pushbutton to return to the previous menu item.
Activate submenu items/selection lists	Submenu items and selection lists are activated by pressing the mode pushbutton "M".
Change a numerical value	A numerical value can only be changed by means of the "+" and "-" pushbuttons. Please note that the "+" pushbutton changes the value (each time the button is pressed, the value increases by 1), while the "-" button is used to go to the position of the value to be changed.
Acknowledge changes	Changes are acknowledged by pressing the mode pushbutton "M". Confirming this (by pressing "OK") writes the value to the non-volatile memory.
Exit	Once setting is complete, the program can be exited via the "EXIT" menu item (acknowledge with the mode pushbutton "M").

The next section contains the full menu structure, which provides an overview of the selection and programming options.



IMPORTANT (NOTE)

The button unit must be available for this purpose. Operating the buttons using a magnetic screwdriver is not permitted.

7.6.1 Parameter description

7.6.1.1 "VIEW" parameter

Temporary display of display values 1 to 9.

The following measured values can be set:

- Output signal in physical unit
265G: Current measured value for gauge pressure, or variable derived from this, such as the fill level
265A: Current measured value for absolute pressure; both with customized unit, corresponds to "OUT" with PROFIBUS PA
Setting changes under "OUT 0%" and "OUT 100 %"; desired unit under "UNIT_OUT"
- Percentage value of output signal
- Output current (not with fieldbus transmitters)
- Pressure (current pressure value in range between lower and upper range limit values set).
Setting changes under "GET 0 % / 100 %" or "SET 0 % / 100 %"; desired unit under "UNIT_p/dp".
- Sensor temperature

7.6.1.2 "GET 0 %" and "GET 100 %" parameters

Setting with applied pressure

7.6.1.3 "SET 0%" and "SET 100 %" parameters

Setting without applied pressure

7.6.1.4 "SHIFT ZERO" parameter

Zero shift and zero position correction

7.6.1.5 "OFFSET SHIFT" parameter

Offset shift

7.6.1.6 "OUT 0 %" and "OUT 100 %" parameters

Setting for output variables

(including LCD "VIEW", display code no.1, and "DISPLAY", display code no. 1)

7.6.1.7 "ALARM CURRENT" parameter

Not with fieldbus transmitters

7.6.1.8 "DISPLAY" parameter

Select LCD display value 1, 2, or 3 (permanent display).

The following values can be displayed:

- Output signal in physical unit
265G: Current measured value for gauge pressure, or variable derived from this, such as the fill level
265A: Current measured value for absolute pressure; with customized unit; corresponds to "OUT" with PROFIBUS PA
Setting changes under "OUT 0%" and "OUT 100 %"; desired unit under "UNIT_OUT"
- Percentage value of output signal
- Output current (not with fieldbus transmitters)

7.6.1.9 "UNIT - p/dp" parameter

Selection list of pressure units for the pressure/differential pressure detected by the sensor, including for LCD display code no. 8 under "VIEW"

7.6.1.10 "UNIT - OUT" parameter

Selection list of "OUT" units (for output variables, e.g., m³, m, l/h) including for LCD display code no. 1 under "VIEW" or "DISPLAY"

7.6.1.11 "CUSTOM" parameter

Activation/deactivation of a freely programmable characteristic

7.6.1.12 "ADDRESS" parameter

Only with fieldbus transmitters

7.7 Configuration with the PC / laptop or handheld terminal

A graphical user interface (DTM) is required for configuration of the transmitter via PC or laptop. For operating instructions, please refer to the software description.

Additional information	Data sheet for the SMART VISION/DTM
Communication protocol	HART® PROFIBUS PA® FOUNDATION Fieldbus
Hardware (for HART®)	FSK modem for PC or laptop
HART handheld terminal (HHT)	e.g., 691HT, HHT275/375, DHH800-MFC

You can use a handheld terminal to read out or configure/calibrate the transmitter. If a communication resistor is installed in the connected supply unit, you can clamp the handheld terminal directly along the 4 ... 20 mA line.

If no communication resistor is present (min. 250 Ω), you will need to install one in the line. The handheld terminal is connected between the resistor and transmitter, not between the resistor and power supply unit.

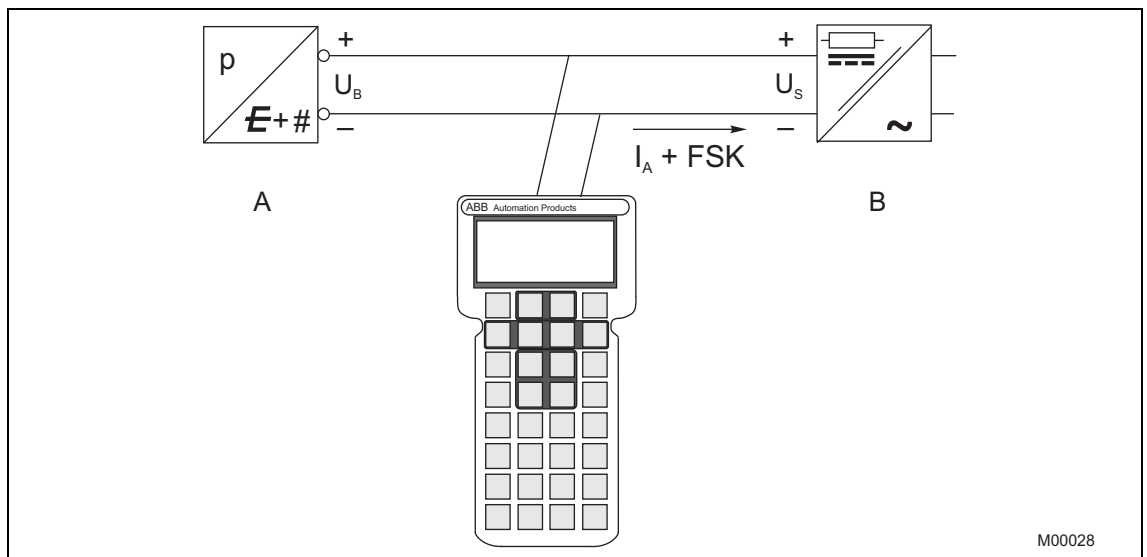

Fig. 22: Communication setup with handheld terminal

A Transmitter

B Supply unit (communication resistor provided in supply unit)

i

IMPORTANT (NOTE)

Communication / configuration / parameterization via handheld terminal / PC where type of protection "intrinsic safety" applies: In this case, the HHT / PC must be appropriately certified; this applies even if it is only connected for a short period of time. This proof of "intrinsic safety" must be supplied in addition to the transmitter.

With type of protection "flameproof enclosure Ex d", the handheld terminal must not be connected in a potentially explosive atmosphere.

The HHT battery must not be replaced in a potentially explosive atmosphere.

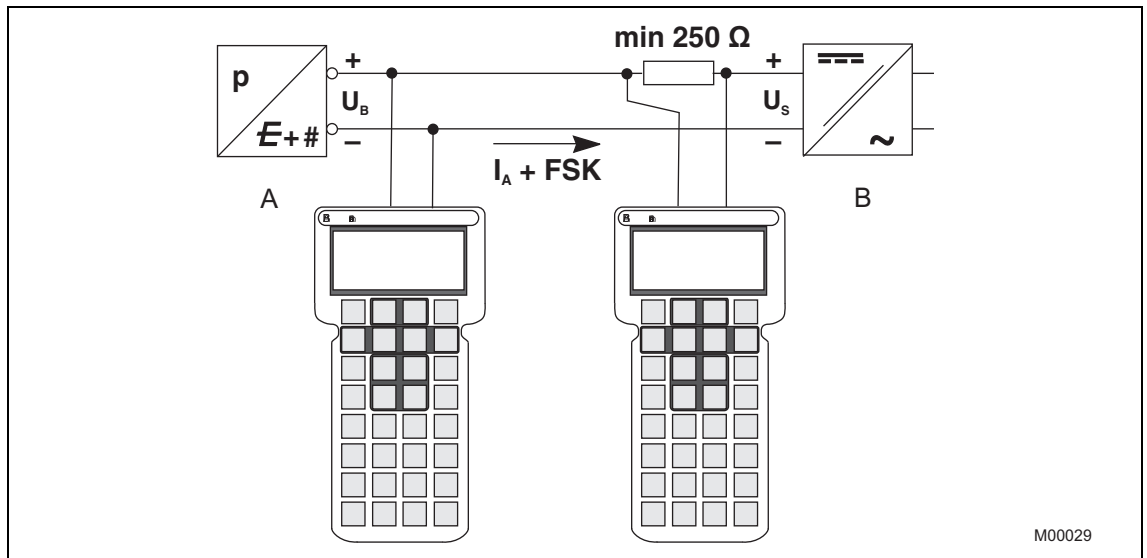

Fig. 23: Connection examples with communication resistor in the connection line

A Transmitter

B Supply unit (communication resistor not provided in supply unit)

For additional information, refer to the operating instructions included with the handheld terminal.

If the transmitter has been configured in the factory according to customer specifications for the measuring point, all you have to do is mount the transmitter as prescribed (to correct potential zero shifts, refer to the section "Correcting the zero shift"), and switch it on. The measuring point will now be ready for use.

If the transmitter is equipped with an LCD indicator, the current pressure/absolute pressure is displayed in % (factory setting, unless otherwise specified).

If, however, you wish to make changes to the configuration, a handheld terminal or - preferably - a graphical user interface (DTM) is required. This DTM tool renders the device fully configurable. It supports both the HART protocol and PROFIBUS PA fieldbus protocol, and can be run on a PC or laptop, or as part of an automation system. Where FOUNDATION Fieldbus is concerned, the device description (DD), which can be loaded onto various configuration tools, is required for configuration purposes.

Refer to the installation manual provided with the software for the steps required to install the operating tool. The most important parameters can be set via the path "Configure_Pressure Measurement".

The program offers the option of configuring, polling, and testing the transmitter. In addition, offline configuration can be performed by means of an internal database. Each configuration step is subject to a plausibility check. You can call up context-sensitive help at any time by pressing the "F1" key.

Immediately after you have received the transmitter or before you change the configuration, we recommend that you save the existing configuration data to a separate data storage medium, via the path "File_Save".

7.8 Configuration with the graphical user interface (DTM)

7.8.1 System requirements

- Operating control program (e.g., SMART VISION version 4.01 or higher)
 - DTM (Device Type Manager; graphical user interface)
 - Operating system (depending on the respective control program)
1. The DTM is started in three stages, either using the right mouse button or via the menu item "Device". First, select "More", followed by "Edit".
 2. When you select "Connect" (the third stage), the full transmitter data should be loaded. Modified data will be underlined in blue.
 3. Use "Save to device" to send this data to the device.



IMPORTANT (NOTE)

Saving the data in the transmitter automatically saves it to the non-volatile memory.

For this purpose, the transmitter must remain connected to the supply power for a further two minutes. Failure to observe this will cause the transmitter to revert to the previous data the next time it is used.

With PROFIBUS devices, "Local Operation" can only be switched off during cyclical communication. If write protection is set using the DTM, it will no longer be possible to change the transmitter setting using the control buttons.

For PROFIBUS devices, the slave address in the user interface project tree must be specified correctly. The communication name and the description are updated automatically when the data is loaded from the device.

The most important calibration and parameterization operations within the user interface are listed in brief below. For additional information on the menu items, refer to the context-sensitive help. Before making any settings, you must ensure that write protection has not been activated, whether on the pressure transmitter itself (button with lock symbol) or within the user interface (menu path: "Configure_Basic Parameters_General_Local Operation").

7.8.2 Setting the damping value

Menu path:

"Configure_Pressure Measurement_Output"

Enter the desired value in the "Damping" line of the "Output parameter" field.

7.8.3 Correcting the zero shift

Menu path:

"Configure_Pressure Measurement_Process Variable"

Press the "Adjust" button in the "Zero shift" field.

Calibration is performed immediately and saved to the failsafe memory in the pressure transmitter.

7.8.4 Setting the lower and upper range limit values

Menu path:

"Configure_Pressure Measurement_Process Variable"

The "Scaling" field offers two setting options:

1. Enter value

Enter the desired values in the "Lower Range Value" and/or "Upper Range Value" input fields.

2. Apply PV

For setting purposes, apply the pressure for the "Lower Range Value" and "Upper Range Value" to the device. Make sure that the measuring limits are not exceeded.

Reducing stations with adjustable pressure and reference displays can be used as pressure generators.

When making the connection, please ensure that there are no residual fluids (for gaseous testing materials) or air bubbles (for fluid testing materials) in the connection lines, since these can lead to errors during inspection.

The measurement deviation for the pressure generator should be at least three times smaller than the desired measurement deviation for the pressure transmitter.

8 Ex relevant specifications

8.1 Potentially explosive atmospheres

ATEX - Transmitter with type of protection "intrinsic safety Ex ia" in accordance with Directive 94/9/EC

Transmitter with 4 ... 20 mA output signal and HART communication:

Certificate no. ZELM 01 ATEX 0064
 Designation: II 1/2G Ex ia IIC T6 or T4
 II 1D Ex iaD 20 T50°C or T95°C
 Ta -40°C... 40°C or 85°C

Power supply and signal circuit with type of protection "intrinsic safety Ex ib IIB/IIC" or "intrinsic safety Ex ia IIB/IIC", for connection to supply units with the following maximum values:

$U_i = 30\text{ V}$
 $I_i = 200\text{ mA}$
 Temperature class T4 or T95°C:
 $P_i = 0.8\text{ W}$ for T4 where $T_a = -40 \dots 85\text{ °C}$
 $P_i = 1.0\text{ W}$ for T4 where $T_a = -40 \dots 70\text{ °C}$

For temperature class T6 or T50°C:
 $P_i = 0.7\text{ W}$ for T6 where $T_a = -40 \dots 40\text{ °C}$

Effective internal capacitance: $C_i = 10\text{ nF}$
 Effective internal inductance: $L_i \approx 0$

265Gx/Ax transmitters with measuring ranges of $\leq 400\text{ mbar}$, which are supplied by an intrinsically safe circuit (Ex ib IIB/IIC), must not be integrated into the partition between Category 1G and 2G.

Fieldbus transmitter (PROFIBUS PA / FOUNDATION Fieldbus):

Certificate no.: ZELM 01 ATEX 0063
 Designation: FISCO field device
 II 1/2G Ex ia IIC T6 or T4
 II 1/2D Ex iaD 20 T50 °C or T95 °C

Power supply and signal circuit with type of protection "intrinsic safety", only for connection to supply units certified according to the FISCO concept and with the following maximum values:

$U_i = 17.5\text{ V}$
 $I_i = 500\text{ mA}$
 $P_i = 8.75\text{ W}$

or connection to supply units or barriers with linear characteristics.

Maximum values:

$U_i = 24\text{ V}$
 $I_i = 250\text{ mA}$
 $P_i = 1.2\text{ W}$

Effective internal inductance: $L_i = 10\text{ }\mu\text{H}$,
 Effective internal capacitance: $C_i = 5\text{ nF}$

Permissible ambient temperature range according to temperature class:

Temperature class	Lower limit of ambient temperature	Upper limit of ambient temperature
T4	-40 °C (-40 °F)	85 °C (185 °F)
T5, T6	-40 °C (-40 °F)	40 °C (104 °F)

265Gx/Ax transmitters with measuring ranges of $\leq 400\text{ mbar}$, which are supplied by an intrinsically safe circuit (Ex ib IIB/IIC), must not be integrated into the partition between Category 1G and 2G.

ATEX - Category 3 transmitter for use in "Zone 2" as defined by Directive 94/9/EC

Transmitter with 4 ... 20 mA output signal and HART communication:

Certificate no.: ZELM 01 ATEX 3059
 Designation: II 3G Ex nA [nL] IIC T6 or T4
 II 3D Ex tD A22 T50°C or T95°C IP6x

Operating conditions:

Supply and signal circuit (terminal signal \pm):

$U \leq 45\text{ V DC}$
 $I \leq 22.5\text{ mA}$

Permissible ambient temperature ranges:

Type of protection "non-sparking nA"

II 3G Ex nA [nL] IIC T6	or	T4:
Ambient temperature		Temperature class
-40 ... +40 °C		T6
-40 ... +85 °C		T4

Type of protection "protection by enclosure tD"

II 3D Ex tD A22 T50°C	or	T95°C IP6x:
Ambient temperature		Surface temperature
-40 ... +40 °C		T50°C
-40 ... +85 °C		T95°C

ATEX - Transmitter with type of protection "flameproof enclosure Ex d" in accordance with Directive 94/9/EC

Transmitter with 4 ... 20 mA output signal and HART communication, and fieldbus transmitter (PROFIBUS PA / FOUNDATION Fieldbus / MODBUS 232 / MODBUS 485):

Certificate no.: PTB 00 ATEX 1018
 Designation: II 1/2 G Ex d IIC T6

Operating conditions:

Supply and signal circuit (terminal signal \pm)

Operating values:

HART	Fieldbus PA/FF	Modbus 232 / 485
$U \leq 45\text{ V DC}$	$U \leq 36\text{ V DC}$	$U \leq 30\text{ V DC}$
$I \leq 22.5\text{ mA}$	$I \leq 14\text{ mA}$	$I \leq 25\text{ mA}$

Ambient temperature range: -40 ... 75 °C

ATEX - Transmitter conforming to 94/9/EC, with type of protection "intrinsic safety i"

or

type of protection "flameproof enclosure d" or type of protection "protection by enclosure tD", or type of protection "non-sparking nA"

(Certificate with alternative types of protection)

Certificate no.: ZELM 04 ATEX 0227 X
Transmitter with 4 ... 20 mA output signal and HART communication:

Designation: II 1/2G Ex ia IIC T6 or T4
II 1D Ex iaD 20 T50°C or T95°C IP6x
(refer to "ATEX Ex ia" previously for additional data)

or

II 1/2 G Ex d IIC T6
(refer to "ATEX Ex d" previously for additional data) or
II 2D Ex tD A21 T50°C or T95°C IP6x
(refer to "ATEX category 3" previously for additional data) or
II 3G Ex nA [nL] IIC T6 or T4
(refer to "ATEX category 3" previously for additional data)

IECEX - Transmitter with the following types of protection: "intrinsic safety i", "non sparking nA", "protection by enclosure tD"

Transmitter with 4 ... 20 mA output signal and HART communication

Certificate no.: IECEX ZLM 09.0005X
Designation: Ex ia IIC T6 or T4 Ga/Gb
Ex iaD 20 T50°C or T95°C
Ex tD A21 T50°C or T 95°C IP6x
Ex nA [nL] IIC T6 or T4
Ta = -40°C to +40°C or + 85°C

Maximum permissible ambient temperature range according to temperature class:

Ambient temperature	Temperature cl.	Surface temp.
-40 ... 85 °C (-40 ... 185 °F)	T4	95 °C (203 °F)
-40 ... 40 °C (-40 ... 104 °F)	T6	50 °C (122 °F)

The following electrical data applies according to designation Ex ia IIC T6 or T4 Ga/Gb, or Ex iaD 20 T50°C or T95°C IP6x

Supply and signal circuit with type of protection "intrinsic safety" Ex ia IIC or Ex ib IIC, or Ex iaD or Ex ibD, for connection to supply units with the following maximum values:

(terminal signal ±): $U_i = 30 \text{ V}$

$I_i = 200 \text{ mA}$

Temperature class T4 or T95°C:

$P_i = 0.8 \text{ W}$ for T4 where $T_a = -40 \dots 85 \text{ °C}$

$P_i = 1.0 \text{ W}$ for T4 where $T_a = -40 \dots 70 \text{ °C}$

For temperature class T6 or T50°C:

$P_i = 0.7 \text{ W}$ for T6 where $T_a = -40 \dots 40 \text{ °C}$

Effective internal capacitance: $C_i = 10 \text{ nF}$

Effective internal inductance: $L_i \approx 0$

265Gx/Ax transmitters with measuring ranges of $\leq 400 \text{ mbar}$ may only be integrated into the partition between Zone 0 and Zone 1 if supplied by an intrinsically safe circuit (Ex ia).

The following electrical data applies according to designation Ex nA [nL] IIC T6 or T4:

Supply and signal circuit (terminal signal ±)

Operating voltage $U \leq 45 \text{ V}$

Operating current $I \leq 22.5 \text{ mA}$

The following electrical data applies according to designation Ex tD A21 T50°C or T95°C IP6x:

Supply and signal circuit

(terminal signal ±)

Operating voltage $U \leq 45 \text{ V}$

Operating current $I \leq 22.5 \text{ mA}$

IECEX - Transmitter with the following types of protection: "intrinsic safety i", "limited energy"

Fieldbus transmitter (PROFIBUS PA / FOUNDATION Fieldbus):

Certificate no.: IECEX ZLM 09.0004X

Designation: Ex ia IIC T6 or T4 Ga/Gb
Ex iaD 20 T50°C or T95°C
Ex nL IIC T6 or T4
Ta = -40°C to +40°C or + 85°C

Maximum permissible ambient temperature range according to temperature class:

Ambient temperature	Temperature cl.	Surface temp.
-40 ... 85 °C (-40 ... 185 °F)	T4	95 °C (203 °F)
-40 ... 40 °C (-40 ... 104 °F)	T6	50 °C (122 °F)

Ex relevant specifications

The following electrical data applies according to designation Ex ia IIC T6 or T4 Ga/Gb, or Ex iaD 20 T50°C or T95°C IP6x

Supply and signal circuit with type of protection "intrinsic safety", only for connection to certified supply units in accordance with the FISCO concept, with the following maximum values:

(terminal signal ±):
 $U_i = 17.5 \text{ V}$
 $I_i = 500 \text{ mA}$
 $P_i = 8.75 \text{ W}$

Effective internal capacitance: $C_i = 5 \text{ nF}$

Effective internal inductance: $L_i = 10 \text{ μH}$

or connection to supply units or barriers with linear characteristics.

Maximum values:

$U_i = 24 \text{ V}$
 $I_i = 250 \text{ mA}$
 $P_i = 1.2 \text{ W}$

Effective internal capacitance: $C_i = 5 \text{ nF}$

Effective internal inductance: $L_i = 10 \text{ μH}$

265Gx/Ax transmitters with measuring ranges of $\leq 400 \text{ mbar}$ may only be integrated into the partition between Zone 0 and Zone 1 if supplied by an intrinsically safe circuit (Ex ia).

The following electrical data applies according to designation Ex nL IIC T6 or T4:

Supply and signal circuit with type of protection "limited energy Ex nL IIC", only for connection to certified supply units in accordance with the FNICO concept, with the following maximum values:

(terminal signal ±):
 $U_i = 17.5 \text{ V}$
 $I_i = 666 \text{ mA}$
 $P_i = 11.65 \text{ W}$

Effective internal capacitance: $C_i = 5 \text{ nF}$

Effective internal inductance: $L_i = 10 \text{ μH}$

IECEX - Transmitter with the following types of protection: "flameproof enclosure "d" and "protection by enclosure tD"

Transmitter with 4 ... 20 mA output signal and HART communication, and fieldbus transmitter (PROFIBUS PA / FOUNDATION Fieldbus / MODBUS 232 / MODBUS 485):

Certificate no.: IECEX ZLM 09.0003X
 Designation: Ex d IIC T6
 Ex tD A21 T85°C IP6x
 $T_a = -40^\circ\text{C to } +75^\circ\text{C}$

The following electrical data applies according to designation Ex d IIC T6 or Ex tD A21 T85°C IP6x:

Supply and signal circuit (terminal signal ±)

Operating values:

HART	Fieldbus PA/FF	Modbus 232 / 485
$U \leq 45 \text{ V DC}$	$U \leq 36 \text{ V DC}$	$U \leq 30 \text{ V DC}$
$I \leq 22.5 \text{ mA}$	$I \leq 14 \text{ mA}$	$I \leq 25 \text{ mA}$

Ambient temperature range: $-40 \dots 75 \text{ °C}$

Factory Mutual (FM)

Transmitter with 4 ... 20 mA output signal and HART communication:

Intrinsically safe

protection: Class I; Division 1; Groups A, B, C, D;
 Class I; Zone 0; Group IIC; AEx ia IIC

Degree of protection: NEMA type 4X (indoor or outdoor installation)

Permissible ambient temperature range according to temperature class:

$U_{\max} = 30 \text{ V}, C_i = 10.5 \text{ nF}, L_i = 10 \text{ μH}$			
Ambient temperature	Temperature class	I_{\max}	P_i
-40 ... 85 °C (-40 ... 185 °F)	T4	200 mA	0.8 W
			1 W
-40 ... 70 °C (-40 ... 158 °F)	T5	25 mA	0.75 W
	T6		0.5 W

Fieldbus transmitter (PROFIBUS PA/FOUNDATION Fieldbus):

Intrinsically safe

protection: Class I, II, and III; Division 1;
 Groups A, B, C, D, E, F, G;
 Class I; Zone 0; AEx ia Group IIC T6, T4;
 Non-incendive Class I, II, and III; Division 2;
 Groups A, B, C, D, F, G

Transmitter with 4 ... 20 mA output signal, HART communication, and fieldbus transmitter (PROFIBUS PA/FOUNDATION fieldbus):

Explosion-proof: Class I, Division 1, Groups A, B, C, D;
 Class II/III, Division 1, Groups E, F, G

Degree of protection: NEMA type 4X (indoor or outdoor installation)

Canadian Standards Association (CSA)

Transmitter with 4 ... 20 mA output signal, HART communication, and fieldbus transmitter (PROFIBUS PA/FOUNDATION fieldbus)

Explosion-proof: Class I, Division 1, Groups B, C, D;
 Class II, Division 1, Groups E, F, G

Degree of protection: NEMA type 4X (indoor or outdoor installation)

**Standards Association of Australia (SAA)
Transmitter with type of protection "flameproof enclosure Ex d"**

Transmitter with 4 ... 20 mA output signal, HART communication, and fieldbus transmitter (PROFIBUS PA/FOUNDATION fieldbus, Modbus):

Designation:
Zone 1: Ex d IIC T6 (Tamb +75 °C) IP 66 / IP 67
Zone A21: Ex tD A21 T85 (Tamb +75 °C) IP 66 / IP 67

**NEPSI (China)
Intrinsic safety**

Transmitter with 4 ... 20 mA output signal and HART communication:

Designation: Ex ia IIC T4/T6

Permissible ambient temperature range according to temperature class:

Temperature class	Ambient temperature	Pi
T4	-40 ... 85 °C (-40 ... 185 °F)	0.8
T4	-40 ... 70 °C (-40 ... 158 °F)	1.0
T6	-40 ... 40 °C (-40 ... 104 °F)	0.7

Supply and signal circuit for connection to supply units with the following maximum values:

$U_{i_{max}} = 30 \text{ V}, I_{i_{max}} = 200 \text{ mA}$			
Temperature class	$P_{i_{max}}$	Max. internal parameters	
		C_i (nF)	L_i (µH)
T6	0.7	47	10
T4	0.8	47	10
T4	1.0	47	10

Fieldbus transmitter (PROFIBUS PA/FOUNDATION Fieldbus)

Designation: Ex ia IIB/IIC T4 ... T6

Permissible ambient temperature range according to temperature class:

Temperature class	Ambient temperature
T4	-40 ... 85 °C (-40 ... 185 °F)
T5	-40 ... 50 °C (-40 ... 122 °F)
T6	-40 ... 40 °C (-40 ... 104 °F)

Supply and signal circuit for connection to supply units with the following maximum values:

Ex mark	Characteristic curve Supply unit	$U_{i_{max}}$ (V)	$I_{i_{max}}$ (mA)	$P_{i_{max}}$ (W)
Ex ia IIC T4 ... T6	Rectangular or trapezoidal	17.5	360	2.52
Ex ia IIB T4 ... T6	Rectangular or trapezoidal	17.5	380	5.32
Ex ia IIC T4 ... T6	Linear	24	250	1.2
$C_{i_{max}}$ (nF)		$L_{i_{max}}$ (µH)		
0		10		

Explosion-proof

Transmitter with 4 ... 20 mA output signal and HART communication, and fieldbus transmitter (PROFIBUS PA/FOUNDATION Fieldbus):

Designation: Ex d IIC T6

Operating conditions

Ambient temperature range: -40 ... 75 °C (-40 ... 167 °F)

9 Specifications

9.1 Functional specifications

Measuring range and span limits

Sensor code	Upper range limit (URL)	Lower range limit (LRL) for 265G	Minimum measuring span	
			265G Gauge pressure	265A Absolute pressure
C	6 kPa 60 mbar 24 in H ₂ O	-6 kPa -60 mbar -24 in H ₂ O	0.2 kPa 2 mbar 0.8 in H ₂ O	0.3 kPa 3 mbar 2.25 mm Hg
F	40 kPa 400 mbar 160 in H ₂ O	-40 kPa -400 mbar -160 in H ₂ O	0.4 kPa 4 mbar 1.6 in H ₂ O	2 kPa 20 mbar 15 mm Hg
L	250 kPa 2,500 mbar 1,000 in H ₂ O	Absolute 0	2.5 kPa 25 mbar 10 in H ₂ O	12.5 kPa 125 mbar 93.8 mm Hg
D	1,000 kPa 10 bar 145 psi	Absolute 0	10 kPa 0.1 bar 1.45 psi	50 kPa 0.5 bar 7.25 psi
U	3,000 kPa 30 bar 435 psi	Absolute 0	30 kPa 0.3 bar 4.35 psi	150 kPa 1.5 bar 21.7 psi
R	10,000 kPa 100 bar 1,450 psi	Absolute 0	100 kPa 1 bar 14.5 psi	500 kPa 5 bar 72.6 psi
V	60,000 kPa 600 bar 8,700 psi	Absolute 0	600 kPa 6 bar 87 psi	

i IMPORTANT (NOTE)

The lower range limit (LRL) for 265A is 0 absolute for all measuring ranges.

Span limits

Maximum span = URL = Upper range limit

To optimize performance characteristics, it is recommended that you select the transmitter sensor with the lowest turndown ratio.

TURNDOWN = Upper range limit/set span

Zero position suppression and elevation

The zero position and span can be set to any value within the range limits listed in the table if:

- Set span \geq minimum span

Damping

Adjustable time constant: 0 ... 60 s

This is in addition to the sensor response time, and can be set via the optional LCD display, handheld terminal, or PC user interface.

Operational readiness

According to technical data, ready for operation in ≤ 2.5 s after switching on the transmitter, with minimum damping.

Insulation resistance

>100 M Ω at 500 V DC (between terminals and ground)

9.2 Operating limits

Temperature limits in °C (°F)

	Ambient temperature range
Operating temperature	-40 ... 85 °C (-40 ... 185 °F)
LCD display	-20 ... 70 °C (-4 ... 158 °F)
White oil filling	-6 ... 85 °C (-21 ... 185 °F)
Viton seal	-20 ... 85 °C (-4 ... 185 °F)
Perfluoroelastomer seal	-25 or -15 ... 80 °C (-13 or 5 ... 176 °F) See section "Pressure limits"

	Process temperature range
Process temperature	-50 ... 120 °C (-58 ... 248 °F)
White oil filling	-6 ... 120 °C (21 ... 248 °F) ¹⁾
Viton seal	-20 ... 120 °C (-4 ... 248 °F)
Perfluoroelastomer seal	-25 °C or -15 ... 80 °C (-13 °F or 5 ... 176 °F) See section "Pressure limits"

1) ≤ 85 °C (185 °F) for operating pressures below the atmospheric pressure

	Storage temperature range
Storage temperature	-50 ... 85 °C (-58 ... 185 °F)
LCD display	-40 ... 85 °C (-40 ... 185 °F)
White oil filling	-6 ... 85 °C (21 ... 185 °F)

	Humidity during storage
Relative humidity	Up to 75 %



IMPORTANT (NOTE)

For applications in potentially explosive atmospheres, the temperature range specified on the relevant certificate/approval must be observed.

9.3 Pressure limits

Overpressure limits

(without damage to the transmitter)

Sensor code	Overpressure limits; Absolute 0 to:
C, F	1 MPa, 10 bar, 145 psi
L	0.5 MPa, 5 bar, 72.5 psi
D	2 MPa, 20 bar, 290 psi
U	6 MPa, 60 bar, 870 psi
R	20 MPa, 200 bar, 2900 psi
V	90 MPa, 900 bar, 13050 psi
Perfluoroelastomer gasket T ≥ -15 °C (5 °F)	0.6 MPa abs, 6 bar abs, 87 psia
Perfluoroelastomer gasket T ≥ -25 °C (-13 °F)	0.18 MPa abs, 1.8 bar abs, 26 psia

Test pressure



IMPORTANT (NOTE)

When testing pressure on the pressure transmitter, please ensure that you observe the overpressure limits.

Specifications

9.4 Environmental limits

Electromagnetic compatibility (EMC)

Conforms to the requirements and tests for EMC Directive 89/336/EC, as well as to EN 61000-6-3 concerning emitted interference and EN 61000-6-2 concerning interference immunity. Meets NAMUR recommendations.

Low Voltage Directive

Complies with 73/23/EC.

Pressure Equipment Directive (PED)

Complies with 97/23/EC Category III, module H.

Humidity

Relative humidity: Up to 100 %
 Condensation, icing: Permissible

Vibration resistance

Acceleration up to 2 g at frequencies up to 1,000 Hz (according to IEC 60068-2-6).

Shock resistance (acc. to IEC 60068-2-27)

Acceleration: 50 g
 Duration: 11 ms

Protection type (humid and dusty atmospheres)

The transmitter is dust and sand-tight, and is protected against immersion effects as defined by the following standards:

- IEC EN 60529 (1989) with IP 67 (with IP 68 on request)
- NEMA 4X
- JIS C0920

Protection type with plug connection: IP 65

9.5 Electrical data and options

HART digital communication and 4 ... 20 mA output current

Power supply

The transmitter operates from 10.5 ... 45 V DC with no load and is protected against reverse polarity connection (additional load allows operations over 45 V DC).

With a backlit LCD display, the minimum voltage is 14 V DC.

For Ex ia and other intrinsically safe approved versions, the supply voltage must not exceed 30 V DC.

Ripple

Maximum permissible supply voltage ripple during communication: Complies with HART FSK "Physical Layer" specification rev. 8.1.

Load limitations

Total loop resistance at 4 ... 20 mA and HART:

$$R(k\Omega) = \frac{\text{Voltage supply} - \text{Minimum operating voltage (VDC)}}{22,5 \text{ mA}}$$

i IMPORTANT (NOTE)

A minimum of 250 Ω resistance is required for HART communication.

LCD display (optional)

19-segment alphanumeric display (two lines, six characters) with additional bar chart display; option of backlighting for customized display of:

- Output current in percent
- Output current in mA
- Freely selectable process variable

Diagnostic messages, alarms, measuring range upper limit violations, and changes to the configuration are also displayed.

Output signal

4 ... 20 mA two-wire output, can be selected by user, linear or freely programmable with 20 reference points.

HART® communication provides digital process variables (% , mA or engineering units) superimposed on the 4 ... 20 mA signal (protocol according to Bell 202 FSK standard).

Output current limits (according to NAMUR standard)

Overload condition:

- Lower limit: 3.8 mA (configurable up to 3.5 mA)
- Upper limit: 20.5 mA (configurable up to 22.5 mA)

Alarm current

Minimum alarm current: Can be configured from 3.5 ... 4 mA, Default setting: 3.6 mA
 Maximum alarm current: Can be configured from 20 ... 22.5 mA; Default setting: 21 mA
 Default setting: Maximum alarm current

SIL: Functional safety (optional)

According to IEC 61 508/61 511

Device with certificate of conformity for use in safety-related applications, up to and including SIL 2.

PROFIBUS PA output
Model

Pressure transmitter conforming to Profile 3.0, Class A and B;
ID number 04C2 HEX

Power supply

The transmitter is operated at 10.2 ... 32 V DC (no polarity).
The supply voltage must not exceed 17.5 V DC when used in Ex ia zones.
Intrinsically safe installation in accordance with FISCO model.

Current consumption

Operating (quiescent): 11.7 mA
Fault current limit value: Maximum 17.3 mA

Output signal

Physical layer in accordance with IEC 1158-2/EN 61158-2;
transmission using Manchester II modulation at 31.25 kbit/sec.

Output interface

PROFIBUS PA communication according to Profibus DP50170 Part
2/DIN 19245 Part 1-3

Output cycle time

40 ms

Function blocks

1 standard analog input function block
1 transducer block
1 physical block

LCD display (optional)

19-segment alphanumeric display (two lines, six characters) with
additional bar chart display; option of backlighting.
Customized display:
Output value in percent or OUT (analog input)
Diagnostic messages, alarms, measuring range upper limit violations,
and changes to the configuration are also displayed.

Transmitter interference mode

Permanent self-diagnosis; potential errors indicated in diagnostic
parameters and in the status of process values.

FOUNDATION Fieldbus output
Power supply

The transmitter is operated at 10.2 ... 32 V DC (no polarity).
The supply voltage must not exceed 17.5 V DC when used in Ex ia zones.
Intrinsically safe installation in accordance with FISCO model.

Current consumption

Operating (quiescent): 11.7 mA
Fault current limit value: Maximum 17.3 mA

Output signal

Physical layer in accordance with IEC 1158-2/EN 61158-2;
transmission using Manchester II modulation at 31.25 kbit/sec.

Function blocks/execution time

1 standard analog input function block/maximum 25 ms,
1 standard PID function block

Additional blocks

1 manufacturer-specific pressure with calibration transducer block
1 enhanced resource block

Number of link objects

10

Number of VCRs

16

Output interface

FOUNDATION Fieldbus digital communication protocol in accordance
with standard H1; complies with specification V. 1.5.
FF registration no.: IT023600

LCD display (optional)

19-segment alphanumeric display (two lines, six characters) with
additional bar chart display; option of backlighting.
Customized display:
Output value in percent or OUT (analog input)
Diagnostic messages, alarms, measuring range upper limit violations,
and changes to the configuration are also displayed.

Transmitter interference mode

Permanent self-diagnosis; potential errors indicated in diagnostic
parameters and in the status of process values.

Specifications

9.6 Measuring accuracy

Reference conditions according to IEC 60770

- Ambient temperature T_U = constant, in range: 18 ... 30 °C (64 ... 86 °F)
- Relative humidity = constant, in range: 30 ... 80 %
- Atmospheric pressure P_U = constant, in range: 950 ... 1,060 mbar
- Position of measuring cell: vertical $\pm 1^\circ$
- Span based on zero position
- Isolating diaphragm material: Ceramic (Al_2O_3), gold-coated, or Hastelloy C276™
- Sensor filling liquid: Silicone oil (sensors ≥ 2.5 bar)
- Supply voltage: 24 V DC
- Load with HART: 250 Ω
- Transmitter not grounded
- Characteristic setting: linear, 4 ... 20 mA

Unless otherwise specified, errors are given as a percentage of the span value.

The accuracy of the measurement in relation to the upper range limit (URL) is affected by the turndown (TD); i.e., the ratio of the upper range limit (URL) to the set span (URL/span).

9.7 Operating influences

Thermal change in ambient temperature as regards zero signal and span (turndown up to 15:1), in relation to the set span

Area	Maximum effect on zero signal and span
-10 ... 60 °C (14 ... 140 °F)	Sensor code C, F: $\pm (0.08 \% \times TD + 0.08 \%)$ Sensor code C, F (abs.): $\pm (0.20 \% \times TD + 0.10 \%)$ Sensor code L, D, U, R, V: $\pm (0.06 \% \times TD + 0.06 \%)$
-40 ... -10 °C (-40 ... 14 °F) and 60 ... 80 °C (140 ... 176 °F)	Sensor code C, F: $\pm (0.04 \% / 10 K \times TD + 0.05 \% / 10 K)$ Sensor code C, F (abs.): $\pm (0.10 \% / 10 K \times TD + 0.05 \% / 10 K)$ Sensor code L, D, U, R, V: $\pm (0.04 \% / 10 K \times TD + 0.04 \% / 10 K)$

Power supply

Within the specified limits for the voltage / load, the total influence is less than 0.001 % of the upper measuring range limit per volt.

Load

Within the specified load / voltage limits, the total influence is negligible.

Electromagnetic fields

Total effect: less than 0.05 % of span from 80 ... 1,000 MHz and for field strengths up to 10 V/m when tested with unshielded conduit, with or without meter.

Mounting position

Nominal position: vertical; process connection at bottom.

IMPORTANT (NOTE)

Select the transmitter sensor with the smallest possible turndown. This optimizes the accuracy of the measurement.

Dynamic response (according to IEC 61298-1)

Devices with standard configurations and a turndown of up to 30:1, plus linear output characteristics.

Reaction time:	30 ms
Time constant (63 %)	150 ms (for all sensors)

Measuring error (for setting cut-off point)

Percentage of set span, consisting of non-linearity, hysteresis, and non-reproducibility.

In the case of fieldbus devices, SPAN refers to the analog input function block output scale range.

Turndown	Measuring error
1:1 to 10:1	$\pm 0.04 \%$
>10:1	$\pm (0.04 + 0.005 \times TD - 0.05) \%$

The filling fluid of the measuring equipment affects the position if the mounting position differs. If the deviation is 90° from the nominal position and silicone oil is used as the filling fluid, this equates to 2.14 mbar + 0.02 mbar/10K.

Long-term stability

$\pm (0.05 \times TD) \% / \text{year}$
 $\pm (0.15 \times TD) \% / 5 \text{ years}$

Vibration effect

$\pm (0.10 \times TD) \% \text{ acc. to IEC 61298-3.}$

Total performance

Similar to DIN 16086

In the range -10 ... 60 °C (14 ... 140 °F), in relation to the set span (TD 1:1):

Sensor code C, F: $\pm 0.16 \%$

Sensor code C, F (abs.): $\pm 0.30 \%$

Sensor code L, D, U, R, V: $\pm 0.13 \%$

The total performance accuracy includes the measuring error (non-linearity including hysteresis and non-reproducibility), as well as the thermal change in the ambient temperature as regards the zero signal and span.

$$E_{perf} = \sqrt{(E_{\Delta 91} + E_{\Delta 92})^2 + E_{lin}^2}$$

E_{perf} = Total performance

$E_{\Delta 91}$ = Effect of the ambient temperature on the zero signal

$E_{\Delta 92}$ = Effect of the ambient temperature on the span

E_{lin} = Measurement deviation (for setting cut-off point)

9.8 Technical specification

i IMPORTANT (NOTE)
Please refer to the ordering information to check the availability of different versions of the relevant model.

Materials

Isolating diaphragm ¹	Ceramic (AL ₂ O ₃); gold-coated; Hastelloy C276™; Hastelloy C276™; gold-coated; Stainless steel (316L / 1.4435)
Process connection ¹	Hastelloy C276™; Stainless steel (316L/1.4404)
¹ Transmitter parts that make contact with the medium	
Seal ¹ (for sensor code C, F only)	Viton™; Perfluoroelastomer (Chemraz™) Buna (NBR)
Sensor filling fluid	Silicone oil, inert filling (carbon fluoride), white oil (FDA)
Mounting bracket	Stainless steel
Sensor housing	Stainless steel (316L / 1.4404)
Electronics housing and cover	Barrel design <ul style="list-style-type: none"> Aluminum alloy with a copper content of ≤ 0.1 %, baked epoxy finish Stainless steel (316L / 1.4404) DIN design <ul style="list-style-type: none"> Aluminum alloy with a copper content of ≤ 0.1 %, baked epoxy finish
O-ring cover	Viton™
Local zero position and span adjustments	Fiber glass-reinforced polycarbonate plastic (removable), no adjustment options for stainless steel housings
Name plate	Stainless steel (304 / 1.4301) or plastic data plate attached to the electronics housing

Calibration

Standard:	0 to upper range limit (URL) for ambient temperature and atmospheric pressure
Optional:	To specified span

Optional accessories

Mounting bracket	For vertical and horizontal 60 mm (2") pipes or wall mounting
LCD display	Pluggable and rotatable design
Additional tag for indicating measuring points	Tag with wire (both stainless steel) attached to the transmitter, with a maximum of 30 characters including spaces.

Lightning protection	Up to 4 kV <ul style="list-style-type: none"> Voltage pulses: 1.2 μs rise time; 50 μs delay time at half value Current pulses: 8 μs rise time; 20 μs delay time at half value Not available for devices with ATEX-Ex nA or Profibus PA/FOUNDATION Fieldbus featuring ATEX-Ex i or FM intrinsically safe designs.
Cleanliness level for oxygen applications	
Certificates (test, design, characteristics, material traceability)	

Process connections

1/2 - 14 NPT internal or external thread; spigot to DIN EN 837-1, G 1/2 B or G 1/2 B (HP) for convex seal; front-bonded diaphragm; for installation in ball valve.

Electrical connections

Two 1/2 - 14 NPT or M20 x 1.5 threaded bores for cable glands directly on housing, or plug connector

- HART: Straight or angled Harting Han 8D (8U) connector and one mating plug.
- FOUNDATION Fieldbus/PROFIBUS PA; 7/8" plug/M12 x 1

Terminals

HART version: Four terminals for signal/external display, for wire cross sections of up to 2.5 mm² (14 AWG), and four connection points for testing and communication purposes
Fieldbus versions: Two signal terminals (bus connection) for wire cross sections of up to 2.5 mm² (14 AWG)

Grounding (optional)

Internal and external ground terminals for wire cross sections of up to 4 mm² (12 AWG) are provided.

Mounting position

The transmitter can be installed in any position. The electronics housing may be rotated 360 °. A stop is provided to prevent overturning.

Weight (without options)

Approx. 1.2 kg
Additional 1.5 kg for stainless steel housing
Additional 0.65 kg for packaging

Packaging

Carton with dimensions of approx. 240 x 140 x 190 mm (9.45 x 5.51 x 7.48 inch)

9.9 Mounting dimensions (not design data)

9.9.1 Pressure transmitter with barrel housing

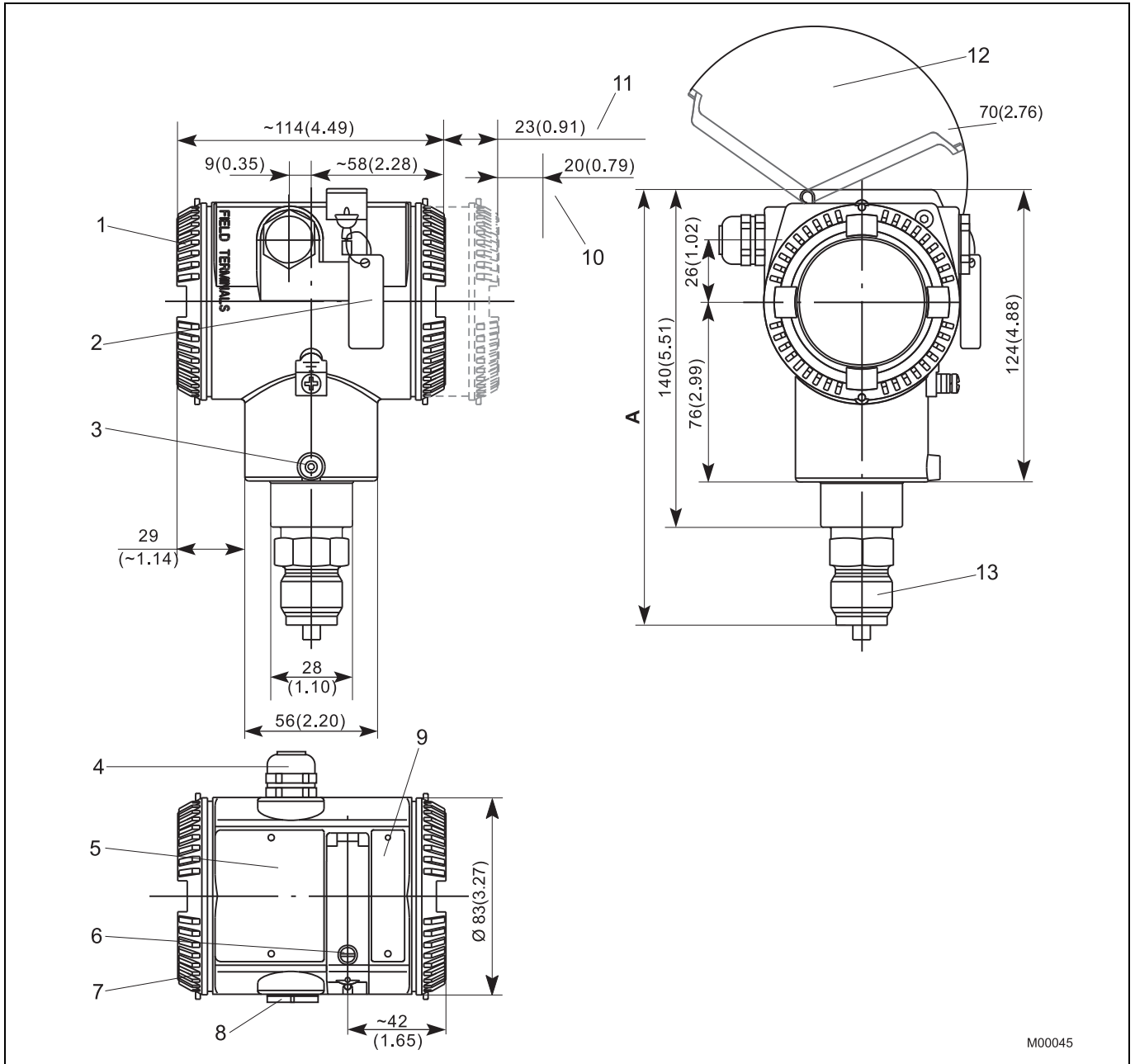

Fig. 24: Dimensions in mm (inch)

- 1 Terminal side
- 2 Tag for indicating measuring points, for example (optional)
- 3 Housing stop screw
- 4 Electrical connection
- 5 Name plate
- 6 Captive fixing screw for keyboard cover
- 7 Housing cover
- 8 Electrical connection (with blind plug)
- 9 Plate with button legend, etc.
- 10 Space required for removing the cover
- 11 With LCD indicator
- 12 Space required for rotating the keyboard cover
- 13 Process connection

Dimension "A" is dependent on the measuring range and process connection.

Process connection	Sensor code C, F	Sensor code L, D, U, R, V
½ -14 NPT male thread	168 (6.61)	173 (6.81)
½ -14 NPT female thread	158 (6.22)	169 (6.65) 172 (6.77) – Sensor V
DIN EN 837-1 G ½ B spigot	167 (6.58)	173 (6.81)
DIN EN 837-1 G ½ B (HP) spigot for connections with convex seal	178 (7.01)	183 (7.20)
Flush diaphragm	-	See pages that follow
For installation in ball valve	-	See pages that follow

9.9.2 Pressure transmitter with DIN housing

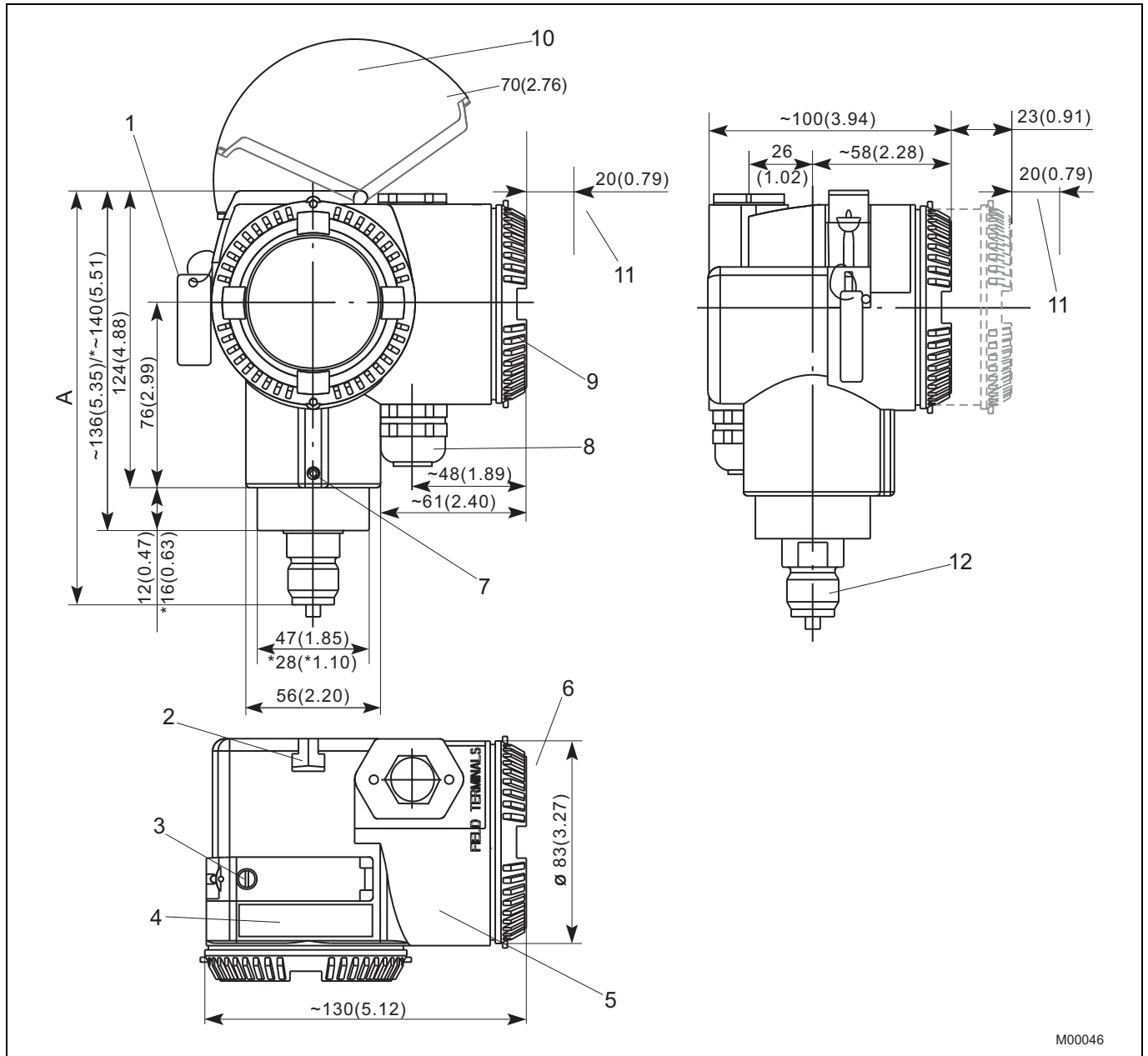

Fig. 25: Dimensions in mm (inch)

- 1 Tag for indicating measuring points, for example (optional)
- 2 Groove for screws (wall or pipe mounting)
- 3 Captive fixing screw for keyboard cover
- 4 Plate with button legend, etc.
- 5 Name plate
- 6 Terminal side
- 7 Housing stop screw
- 8 Electrical connection
- 9 Housing cover
- 10 Space required for rotating the keyboard cover
- 11 Space for removing the cover required
- 12 Process connection

* Dimensions for sensor code L, D, U, R, V

Dimension "A" is dependent on the measuring range and process connection.

Process connection	Sensor code C, F	Sensor code L, D, U, R, V
½ -14 NPT male thread	168 (6.61)	173 (6.81)
½ -14 NPT female thread	158 (6.22)	169 (6.65) 172 (6.77) – Sensor V
DIN EN 837-1 G ½ B spigot	167 (6.58)	173 (6.81)
DIN EN 837-1 G ½ B (HP) spigot for connections with convex seal	178 (7.01)	183 (7.20)
Flush diaphragm	-	See pages that follow
For installation in ball valve	-	See pages that follow

9.9.3 Pressure transmitter with front-bonded diaphragm (barrel housing)

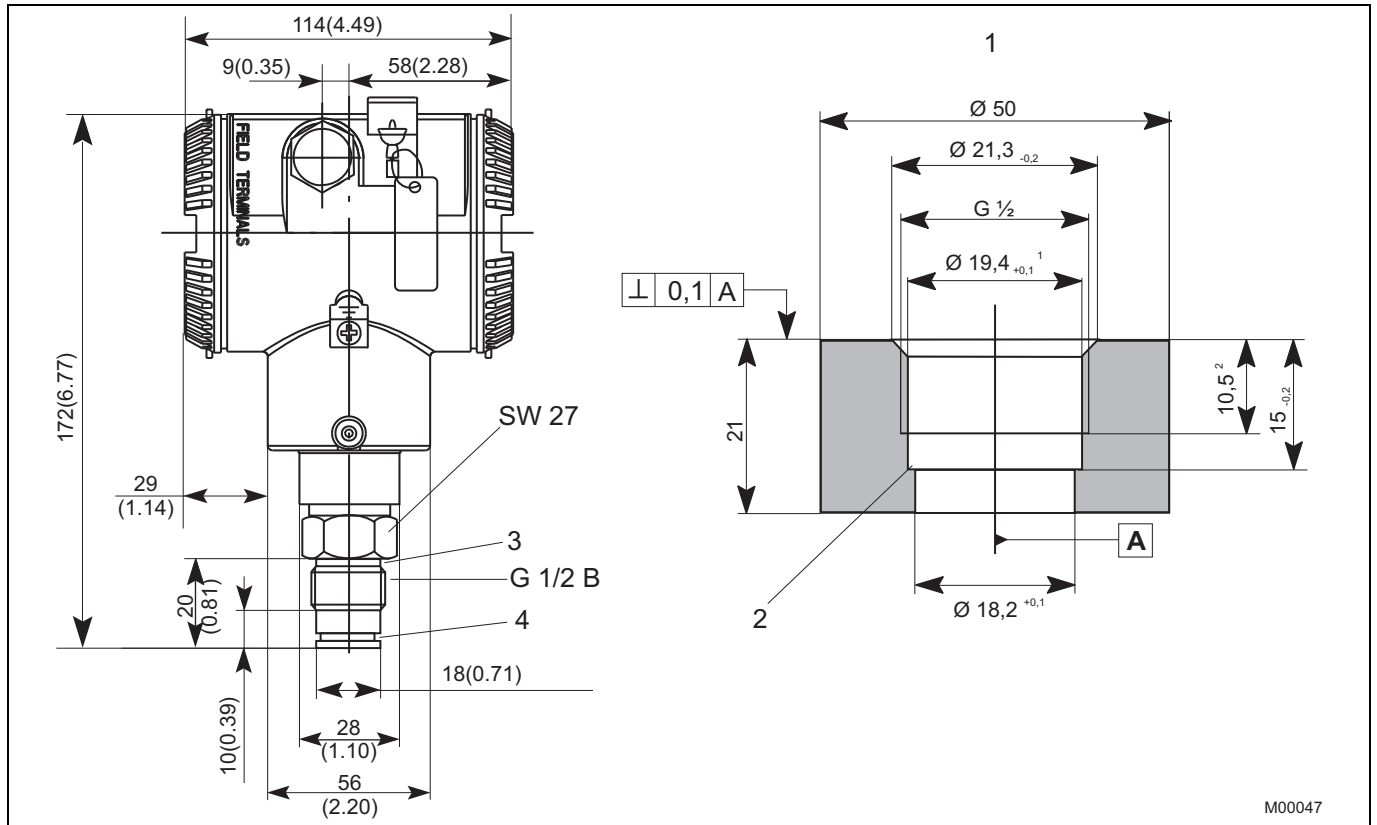

Fig. 26: Dimensions in mm (inch)

- 1 Welded connections/tapped hole for front-bonded diaphragm (part no.: 284903)
- 2 No burrs

- 3 Groove for gasket DIN 3869 - 21 18.5 x 23.9 x 1.5
- 4 Groove for O-ring 15 x 2

- ¹ Bevel after cutting threads
- ² Minimum dimension

9.9.4 Pressure transmitter with ball valve connection (barrel housing)

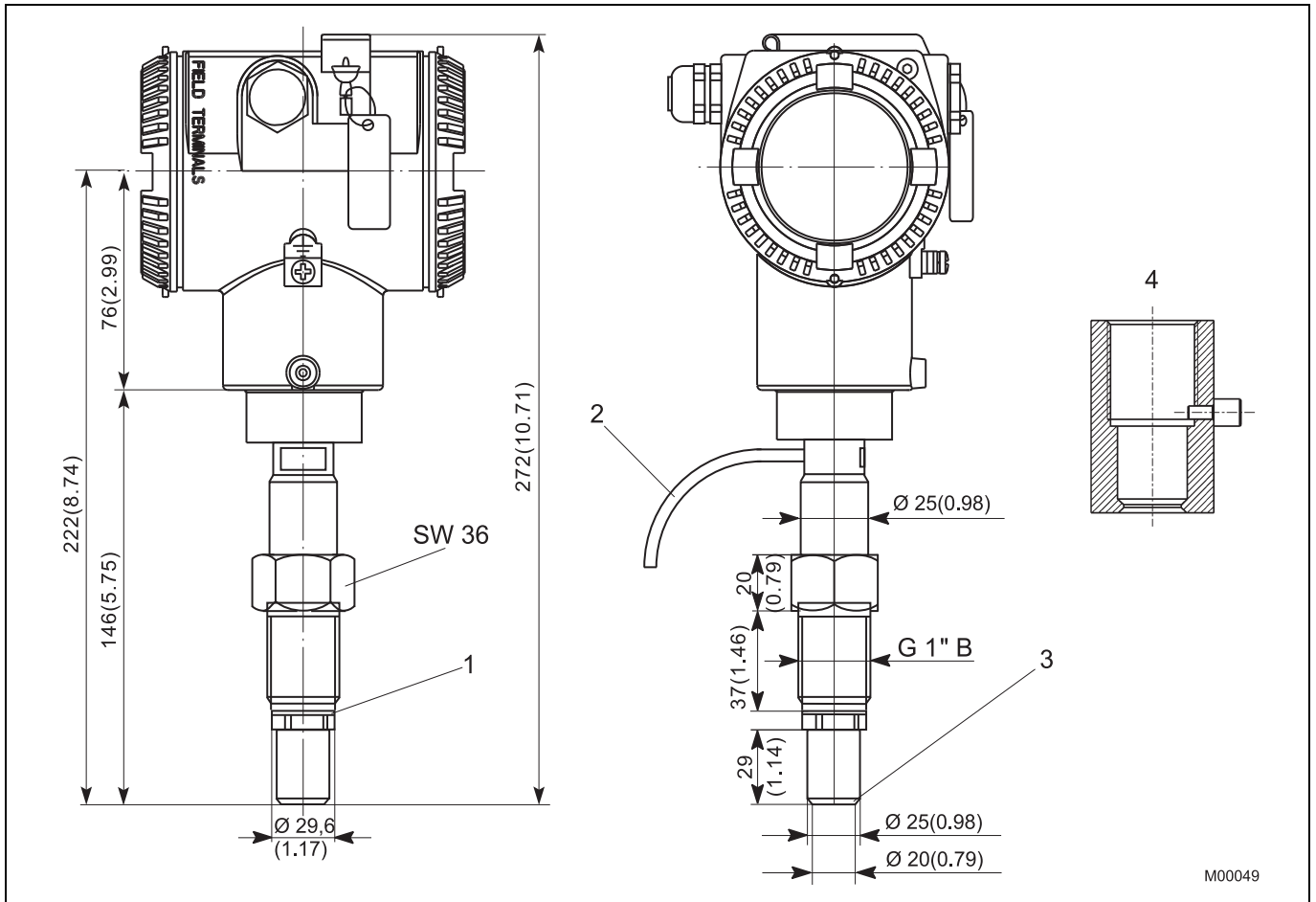

Fig. 27: Dimensions in mm (inch)

- 1 Washer
- 2 Ventilation hose
- 3 Conical seal, metal/metal, diaphragm is process-bonded
- 4 Weld-in sleeve G 1" (part no.: 789516)

9.9.5 Mounting with bracket for barrel housing (option)

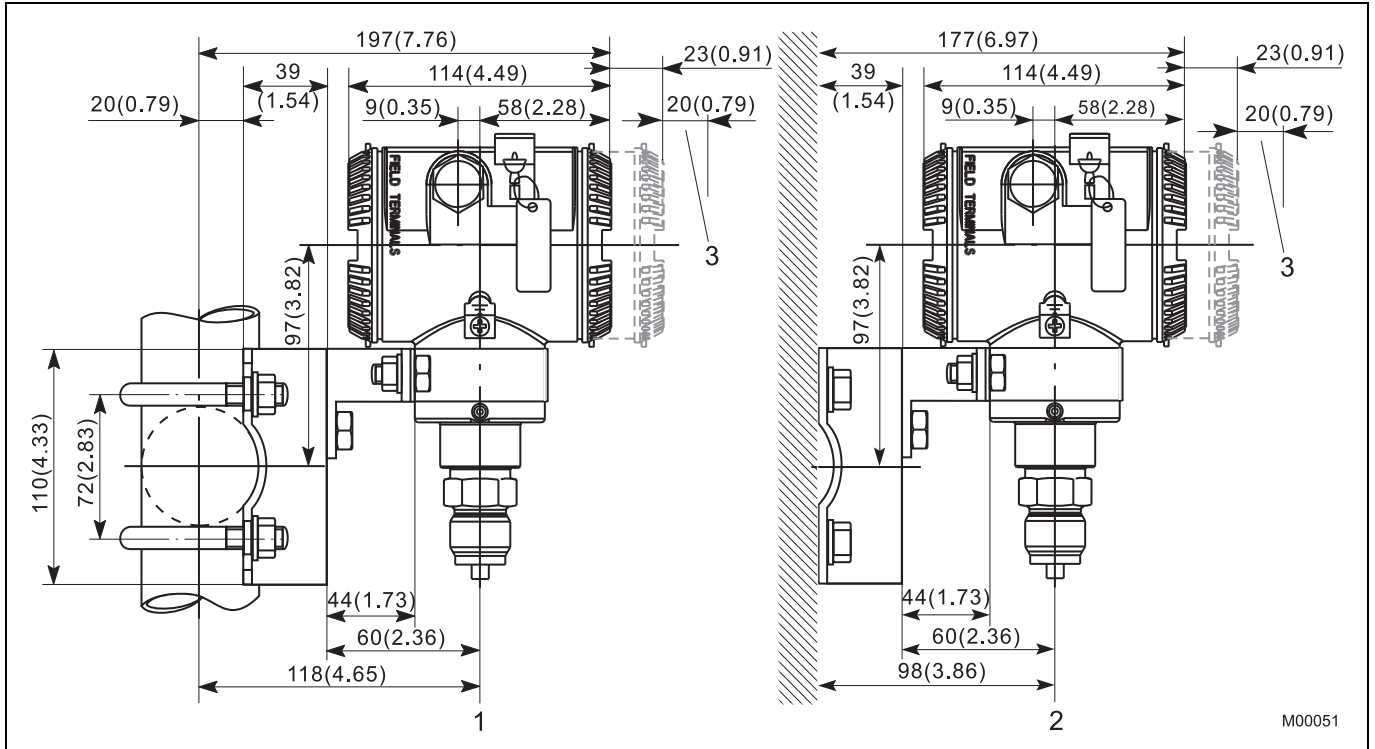

Fig. 28: Dimensions in mm (inch)

- 1 Pipe mounting
- 2 Wall mounting
- 3 Space required for removing the cover



IMPORTANT (NOTE)

The bracket for wall or pipe mounting has four holes (Ø 11 mm). The holes are arranged in a square and spaced 72 mm away from one another.

9.9.6 Mounting with bracket for DIN housing (option)

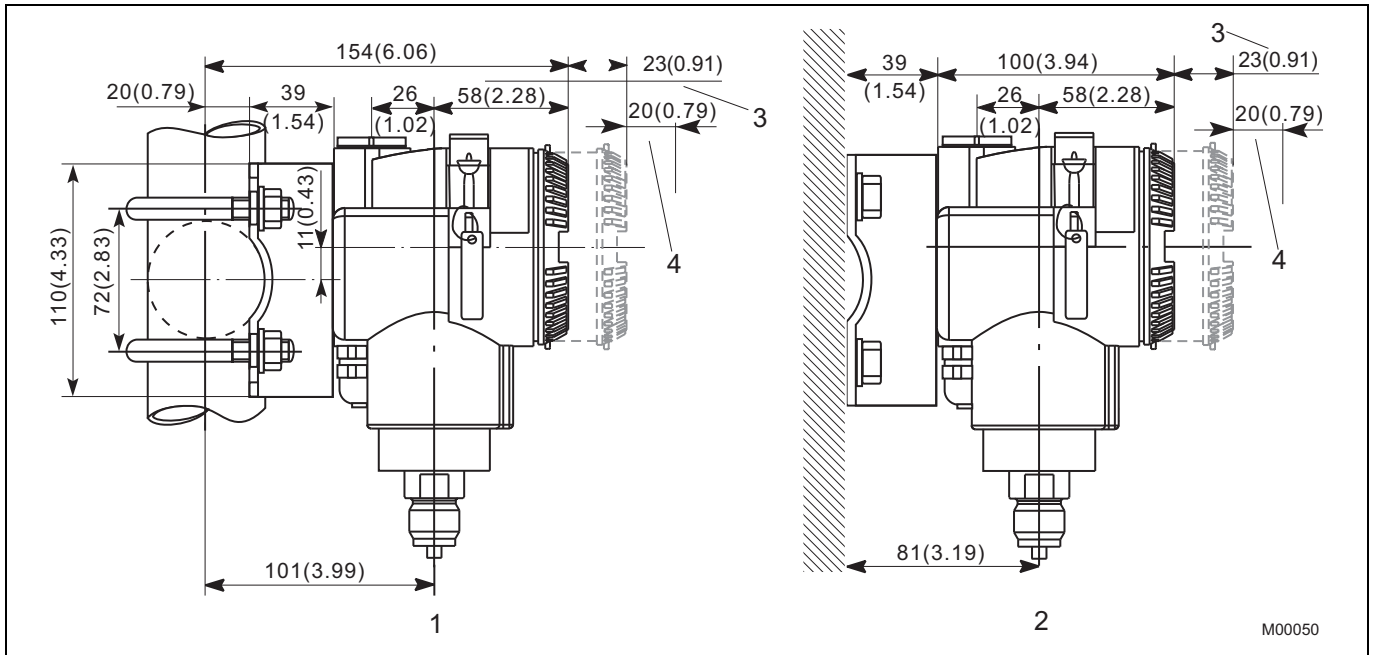

Fig. 29: Dimensions in mm (inch)

- 1 Pipe mounting
- 2 Wall mounting

- 3 With LCD display
- 4 Space required for removing the cover

10 Maintenance / Repair

If pressure transmitters are used as intended under normal operating conditions, no maintenance is required. It is sufficient to check the output signal at regular intervals (in accordance with the operating conditions), as described in the instructions in the section "Operation". If deposits are expected to accumulate, the measuring equipment should be cleaned on a regular basis, in accordance with the operating conditions. Cleaning should ideally be carried out in a workshop.

**NOTICE - Potential damage to parts!**

If a remote seal is mounted on the measuring equipment, it must not be removed.

**WARNING - General dangers!**

Explosion-proof transmitters must be either repaired by the manufacturer or approved by a certified expert following repair work. The relevant safety precautions must be taken before, during, and after repair work.

Only disassemble the transmitter to the extent necessary for cleaning, inspection, repairs, and replacement of damaged components. The measuring equipment, either on its own or with a direct mount remote seal, may only be repaired by the manufacturer.

Returns

Defective transmitters sent to the repairs department must, wherever possible, be accompanied by your own description of the fault and its underlying cause.

**IMPORTANT (NOTE)**

Please use the form for returned products, provided in the Appendix.

This helps us to perform repairs quickly and without the need to contact you for further details. Before you return the device, please clean it and pack it safely and securely. When ordering spare parts or replacement devices, please quote the serial number (S/N) of the original device as well as the year of manufacture (Yr.).

10.1 Removal



WARNING - General dangers!

Before removing or disassembling the device, check for hazardous process conditions such as pressure on the device, high temperatures, aggressive or toxic media, and so on.

Read the instructions in the sections "Safety" and "Electrical connection", and perform the steps outlined there in reverse order.

10.1.1 Removing the electronics

If the electronics housing needs to be unscrewed from the measuring equipment/measuring cell, the electronics must first be removed from their housing to prevent them from being damaged.

1. First, unscrew the housing cover.



NOTICE - Potential damage to parts

Please note that a locking screw is used.

2. Following this, remove the LCD display (if present) from the electronics. To do this, slacken the two screws.
3. Slacken the two fixing screws for the electronics and carefully remove the electronics from their housing.
4. Remove both plugs from the electronics. Both plugs feature mechanical polarity protection, and the smaller of the two also has a mechanical locking device.
5. Grasp the two plugs from the front between your thumb and forefinger, and push them together. This opens the locking device.
6. Pull the plug out of the socket. Place the electronics on a suitable surface.
7. Unscrew the electronics housing from the measuring equipment/measuring cell.



10.1.2 Screw torques for the process connection

Process connection	tightening torque
1/2-14 NPT internal / external thread	50 Nm
DIN EN 837-1 G ½ B	95 Nm ¹⁾

1) In the case of copper flat gaskets

11 Appendix

11.1 Approvals and certifications

	Symbol	Description
CE mark		<p>The CE mark indicates that the device complies with the following directives and their basic safety requirements:</p> <ul style="list-style-type: none"> • CE mark on the name plate of the pressure transmitter <ul style="list-style-type: none"> – Conforms to EMC Directive 2004/108/EC – Conforms to Low Voltage Directive 2006/95/EC – Conforms to Pressure Equipment Directive (PED) 97/23/EC <p>By placing the CE mark on its devices, ABB Automation Products GmbH declares that they conform to these directives.</p>
Explosion protection approvals		<p>This symbol indicates devices with an explosion-proof design.</p> <p>With Ex designs, if this symbol appears on an additional name plate it means that the following also applies:</p> <ul style="list-style-type: none"> – Conformity to ATEX Directive 94/9/EC <p>By placing the Ex mark on its devices, ABB Automation Products GmbH declares that they conform to this directive.</p>



IMPORTANT (NOTE)

All documentation, declarations of conformity, and certificates are available in ABB's download area.

www.abb.com/pressure



EG-KONFORMITÄTSERKLÄRUNG

EC DECLARATION OF CONFORMITY
 ATTESTATION DE CONFORMITE C.E.

Hersteller: ABB Automation Products GmbH
Manufacturer / Fabricant: **Minden**

Anschrift: Schillerstraße 72
Address / Adresse: **D-32425 Minden**

Produktbezeichnung: Druck-Messumformer - 265A, 265D, 265G, 265J, 265V, 267/269C, 267/269J
Product name: Pressure Transmitter – 265A, 265D, 265G, 265J, 265V, 267/269C, 267/269J
Désignation du produit: Transmetteur de Pression – 265A, 265D, 265G, 265J, 265V, 267/269C, 267/269J

Das Produkt stimmt mit den Vorschriften folgender Europäischer Richtlinien überein:

*This product meets the requirements of the following European directives:
 Les produits répondent aux exigences des Directives C.E. suivantes:*

- 2004/108/EG** **EMV-Richtlinie ***
*2004/108/EC Electromagnetic Compatibility Directive **
*2004/108/CE Directives concernant la compatibilité électromagnétique **
 - 2006/95/EG** **Niederspannungsrichtlinie ***
*2006/95/EC EC-Low-Voltage Directive **
*2006/95/CE Directives concernant la basse tension **
 - 97/23/EG** **Druckgeräterichtlinie, Kategorie III Modul H** **(für Druck PS > 200bar)**
97/23/EEC Pressure Equipment Directive, Category III Module H (for pressure PS > 200 bar)
97/23/C.E.E. Directive Equipements sous Pression, Catégorie III Module H (pour pression PS > 200 bar)
- Druck/Pressure/Pression PS ≤ 200bar: SEP**

CE 0045

Für Geräte in Ex-Ausführung gemäß Kennzeichnung auf Typschild gilt zusätzlich:

*For products in Ex design according to identification on nameplate the following is additionally applicable:
 Pour des produits en exécution Ex selon marque sur plaque signalétique le suivant est aussi applicable:*



- 94/9/EG** **ATEX-Richtlinie**
94/9/EEC ATEX Directive
94/9/C.E.E. ATEX Directive

*** einschließlich Änderungen und deutscher Umsetzung durch das EMVG und Gerätesicherheitsgesetz**

** including alterations and German realization by the EMC law and the instruments safety law*

** y compris les modifications et la réalisation allemande par la loi concernant la compatibilité électromagnétique et la sécurité d'appareils*

Die Übereinstimmung mit den Vorschriften dieser Richtlinien wird nachgewiesen durch die vollständige Einhaltung folgender Normen:

*Conformity with the requirements of these Directives is proven by complete adherence to the following standards:
 La conformité avec les exigences de ces directives est prouvée par l'observation complète des normes suivantes:*

EN 61 000-6-1 / EN 61 000-6-2 / EN 61 000-6-3 / EN 61 000-6-4 / EN 61 010-1

Ex: Es gelten die Normen der entsprechenden EG-Baumusterprüfbescheinigungen

*The standards of the relevant type-examination certificates shall apply
 Il convient d'appliquer les normes des certificats d'homologation CE*

15.02.2011

Datum
 Date
 Date

Dr. Wolfgang Scholz
 Leiter R&D
 Head of R&D
 Responsable R&D

Manfred Klüppel
 Leiter Qualitätssicherung
 Head of Quality Assurance
 Responsable Assurance de la Qualité

Statement on the contamination of devices and components

Repair and / or maintenance work will only be performed on devices and components if a statement form has been completed and submitted.

Otherwise, the device / component returned may be rejected. This statement form may only be completed and signed by authorized specialist personnel employed by the operator.

Customer details:

Company:

Address:

Contact person:

Telephone:

Fax:

E-mail:

Device details:

Type:

Serial no.:

Reason for the return/description of the defect:

Was this device used in conjunction with substances which pose a threat or risk to health?

Yes No

If yes, which type of contamination (please place an X next to the applicable items)?

Biological Corrosive / irritating Combustible (highly / extremely combustible)

Toxic Explosive Other toxic substances

Radioactive

Which substances have come into contact with the device?

1.

2.

3.

We hereby state that the devices / components shipped have been cleaned and are free from any dangerous or poisonous substances.

Town/city, date

Signature and company stamp

12 Index

A	
Appendix	84
Approvals and certifications	84
Aspects of Ex safety and IP protection for Australian applications	19
Assembling and connecting the socket connector	32
C	
Cable connection	28
Canadian Standards Association (CSA)	
Category 3 for use in	16
Commissioning	38
Communication setup	34
Compliance with Pressure Equipment Directive (97/23/EC)	11
Configuration	47
Configuration types	49
Configuration with the graphical user interface (DTM)	64
Configuration with the LCD display	52
Configuration with the PC / laptop or handheld terminal	62
Configuring the parameters without an LCD display	50
Connecting cable	36
Contamination of devices	86
Correcting the lower range value / zero shift	40
D	
Design and function	21
Disposal	13
E	
Electrical connection in the cable connection area	29
Electrical connection with plug	31
Electrical data and options	72
Environmental limits	72
Ex relevant specifications	66
F	
Factory settings	47
Functional specifications	70
G	
General information and notes for the reader	6
H	
Hazardous materials	13
I	
Improper use	7
Impulse line	27
Information on WEEE Directive 2002/96/EC	13
Installing / Removing the button unit	41
Installing / Removing the LCD display	42
Integrated lightning protection (optional)	33
Integrated management system	13
Intended use	6
IP designation	25
L	
Layout and contents of the LCD display	55
M	
Maintenance / Repair	82
Maintenance safety information	12
Measuring accuracy	74
Menu structure	57
Menu-controlled pressure transmitter programming	59
Moisture	27
Mounting	25
Mounting dimensions	76
Mounting with bracket for barrel housing (option)	80
Mounting with bracket for DIN housing (option)	81
N	
Name plate	9
Note symbols	8
O	
Operating influences	74
Operating limits	71
Operation	46
Operation using the control buttons on the transmitter	46
Output signal	39
P	
Parameter description	60
Plates and symbols	8
Potentially explosive atmospheres	66
Pressure limits	71
Pressure transmitter	26
Pressure transmitter with ball valve connection (barrel housing)	79
Pressure transmitter with barrel housing	76
Pressure transmitter with DIN housing	77
Pressure transmitter with front-bonded diaphragm (barrel housing)	78
Principle of operation and construction	22
PROFIBUS PA pressure transmitter	37
Protective conductor / Grounding	33
R	
Removal	83
Returning devices	13
RoHS Directive 2002/95/EC	14

Index

S	
Safety	6
Safety instructions for electrical installation	12
Sealing and screw connections	26
Securing the housing cover with Ex d	44
Sensor ventilation	45
Specifications	70
T	
Target groups and qualifications	7
Technical limit values	6
Technical specification	75
Transport and storage	12
Turning the housing in relation to the measuring equipment	41
Type of protection	18
Type of protection	15, 17
Type-examination certificate/Declaration of conformity	15
U	
Use in areas with combustible dust	16
Use in potentially explosive atmospheres	15
W	
Warranty	7
Warranty provisions	7
Write protection	39

ABB has Sales & Customer Support
expertise in over 100 countries worldwide.

www.abb.com/pressure

The Company's policy is one of continuous product
improvement and the right is reserved to modify the
information contained herein without notice.

Printed in the Fed. Rep. of Germany (08.2011)

© ABB 2011

3KXP200003R4201



ABB Ltd.
Howard Road, St. Neots
Cambridgeshire, PE19 8EU
UK
Tel: +44 (0)1480 475 321
Fax: +44 (0)1480 217 948

ABB Inc.
125 E. County Line Road
Warminster, PA 18974
USA
Tel: +1 215 674 6000
Fax: +1 215 674 7183

ABB Automation Products GmbH
Schillerstr. 72
32425 Minden
Germany
Tel: +49 551 905-534
Fax: +49 551 905-555

IM/265G*/Ax-EN-07