

**EN**  
English

**Commissioning Instructions**  
Electromagnetic Flowmeter  
FSM4000



**HART**  
COMMUNICATION PROTOCOL

**PROFI**  
BUS

**Fieldbus**  
Foundation

**ABB**



# Electromagnetic Flowmeter FSM4000

## Commissioning Instruction - EN

D184B141U02

07.2010

Rev. A

### Manufacturer:

#### **ABB Automation Products GmbH**

Dransfelder Straße 2

D-37079 Göttingen

Germany

Tel.: +49 551 905-534

Fax: +49 551 905-555

#### **Customer service center**

Phone: +49 180 5 222 580

Fax: +49 621 381 931-29031

[automation.service@de.abb.com](mailto:automation.service@de.abb.com)

© Copyright 2010 by ABB Automation Products GmbH

Subject to changes without notice

This document is protected by copyright. It assists the user in safe and efficient operation of the device. The contents of this document, whether whole or in part, may not be copied or reproduced without prior approval by the copyright holder.

# Contents

<b>1</b>	<b>Safety</b> .....	<b>4</b>
1.1	General information and notes for the reader .....	4
1.1.1	Safety-/ warning symbols, note symbols.....	5
1.2	Intended use.....	6
1.3	Improper use .....	6
1.4	Target groups and qualifications .....	6
1.5	Warranty provisions.....	6
1.6	Transport safety information .....	6
1.7	Installation safety information.....	7
1.8	Electrical installation safety information .....	7
1.9	Safety instructions for operation.....	7
1.10	Technical limit values .....	8
1.11	Allowed Fluids .....	8
1.12	Maintenance and inspection safety information.....	8
<b>2</b>	<b>Transport</b> .....	<b>9</b>
2.1	Inspection .....	9
2.2	General information on transport .....	9
2.3	Transport of flanged units up to nominal diameter DN 300 .....	9
2.4	Transport of flanged units larger than nominal diameter DN 350 .....	10
<b>3</b>	<b>Mounting</b> .....	<b>11</b>
3.1	General information on installation.....	11
3.2	Supports for nominal diameters larger than DN 350.....	11
3.3	Mounting the meter tube .....	12
3.4	Torque information .....	13
3.4.1	Flanged units and units with adapter flange, model SE41F / SE21F / SE21W .....	13
3.4.2	Variable process connections model SE21 .....	16
3.5	Information on 3A conformity .....	17
3.6	Installation Requirements .....	18
3.6.1	Electrode axis.....	18
3.6.2	In- and outlet pipe sections .....	18
3.6.3	Vertical connections .....	18
3.6.4	Horizontal connections.....	18
3.6.5	Free inlet or outlet .....	18
3.6.6	Strongly contaminated fluids .....	18
3.6.7	Installation in the vicinity of pumps .....	19
3.6.8	Installing the high temperature design .....	19
3.6.9	Installation in pipelines with larger nominal diameter .....	19
3.7	Ground.....	20
3.7.1	General information on ground connections .....	20
3.7.2	Metal pipe with fixed flanges .....	20
3.7.3	Metal pipe with loose flanges .....	21
3.7.4	Non-metallic pipes or pipes with insulating liner .....	21
3.7.5	Flowmeter sensor in stainless steel design model SE21 .....	22
3.7.6	Ground for devices with protective plates.....	22
3.7.7	Ground with conductive PTFE grounding plate .....	22
<b>4</b>	<b>Electrical connections</b> .....	<b>23</b>
4.1	Preparing and routing the signal and magnet coil cable .....	23
4.2	Connecting the flowmeter sensor.....	25
4.2.1	Connecting the signal and magnet coil cables.....	25
4.2.2	Protection class IP 68 .....	26
4.3	Terminal connection diagrams .....	28

---

4.4	Connection examples for peripherals (incl. HART).....	31
<b>5</b>	<b>Commissioning.....</b>	<b>33</b>
5.1	Preliminary checks prior to start-up.....	33
5.1.1	Switching on supply power.....	34
5.2	Commissioning PROFIBUS PA units.....	35
5.2.1	Information on voltage/current consumption.....	37
5.2.2	System integration .....	37
5.3	Commissioning FOUNDATION Fieldbus units.....	38
<b>6</b>	<b>Parameterization.....</b>	<b>40</b>
6.1	Data entry .....	40
6.2	Entering data in "short form".....	42
6.3	Easy Set-up: For uncomplicated configuration .....	43
<b>7</b>	<b>Appendix .....</b>	<b>44</b>
7.1	Other applicable documents .....	44
7.2	Approvals and certifications .....	44

## **1 Safety**

### **1.1 General information and notes for the reader**

You must read these instructions carefully prior to installing and commissioning the device.

These instructions are an important part of the product and must be kept for future reference.

These instructions are intended as an overview and do not contain detailed information on all designs for this product or every possible aspect of installation, operation and maintenance.

For additional information or if specific problems occur that are not discussed in these instructions, contact the manufacturer.

The content of these instructions is neither part of any previous or existing agreement, promise or legal relationship nor is it intended to change the same.

This product is built based on state-of-the-art technology and is operationally safe. It has been tested and left the factory in perfect working order from a safety perspective. The information in the manual must be observed and followed in order to maintain this state throughout the period of operation.

Modifications and repairs to the product may only be performed if expressly permitted by these instructions.

Only by observing all of the safety instructions and all safety/warning symbols in these instructions can optimum protection of both personnel and the environment, as well as safe and fault-free operation of the device, be ensured.

Information and symbols directly on the product must be observed. They may not be removed and must be fully legible at all times.

**1.1.1 Safety-/ warning symbols, note symbols**



**DANGER – <Serious damage to health / risk to life>**

This symbol in conjunction with the signal word "Danger" indicates an imminent danger. Failure to observe this safety information will result in death or severe injury.



**DANGER – <Serious damage to health / risk to life>**

This symbol in conjunction with the signal word "Danger" indicates an imminent electrical hazard. Failure to observe this safety information will result in death or severe injury.



**WARNING – <Bodily injury>**

This symbol in conjunction with the signal word "Warning" indicates a possibly dangerous situation. Failure to observe this safety information may result in death or severe injury.



**WARNING – <Bodily injury>**

This symbol in conjunction with the signal word "Warning" indicates a potential electrical hazard. Failure to observe this safety information may result in death or severe injury.



**CAUTION – <Minor injury>**

This symbol in conjunction with the signal word "Caution" indicates a possibly dangerous situation. Failure to observe this safety information may result in minor or moderate injury. This may also be used for property damage warnings.



**ATTENTION – <Property damage>!**

The symbol indicates a potentially damaging situation.

Failure to observe this safety information may result in damage to or destruction of the product and/or other system components.



**IMPORTANT (NOTICE)**

This symbol indicates operator tips, particularly useful information, or important information about the product or its further uses. It does not indicate a dangerous or damaging situation.

## 1.2 Intended use

This device is intended for the following uses:

- To transmit fluid, pulpy or pasty substances with electrical conductivity.
- To measure the flowrate of the operating volume or mass flow units (at constant pressure / temperature), if a mass engineering unit is selected.

The following items are included in the intended use:

- Read and follow the instructions in this manual.
- Observe the technical ratings; refer to the section 1.10 „Technical limit values“.
- Use only allowed liquids for measurement; refer to the section “Allowed Fluids”.

## 1.3 Improper use

The following are considered to be instances of improper use of the device:

- Operation as a flexible adapter in piping, e.g., to compensate for pipe offsets, pipe vibrations, pipe expansions, etc.
- As a climbing aid, e. g., for mounting purposes
- As a support for external loads, e. g., as a support for piping, etc.
- Adding material, e. g., by painting over the name plate or welding/soldering on parts
- Removing material, e. g., by spot drilling the housing

## 1.4 Target groups and qualifications

Installation, commissioning, and maintenance of the product may only be performed by trained specialist personnel who have been authorized by the plant operator to do so. The specialist personnel must have read and understood the manual and comply with its instructions.

Prior to using corrosive and abrasive materials for measurement purposes, the operator must check the level of resistance of all parts coming into contact with the materials to be measured. ABB Automation Products GmbH will gladly support you in selecting the materials, but cannot accept any liability in doing so.

The operators must strictly observe the applicable national regulations with regards to installation, function tests, repairs, and maintenance of electrical products.

## 1.5 Warranty provisions

Using the device in a manner that does not fall within the scope of its intended use, disregarding this instruction, using underqualified personnel, or making unauthorized alterations releases the manufacturer from liability for any resulting damage. This renders the manufacturer's warranty null and void.

## 1.6 Transport safety information

- Depending on the device, the center of gravity may not be in the center of the equipment.
- The protection plates or protective caps installed on the process connections of devices lined with PTFE / PFA must not be removed until just before installation; to prevent possible leakage, make sure that the liner on the flange is not cut or damaged.

## 1.7 Installation safety information

Observe the following instructions:

- The flow direction must correspond to the direction indicated on the device, if labeled.
- Comply with the maximum torque for all flange bolts.
- Install the devices without mechanical tension (torsion, bending).
- Install flange and wafer type units with coplanar counter flanges.
- Only install devices for the intended operating conditions and with suitable seals.
- Secure the flange bolts and nuts against pipeline vibrations.

## 1.8 Electrical installation safety information

The electrical connection may only be performed by authorized specialists according to the electrical plans.

Comply with electrical connection information in the manual. Otherwise, the electrical protection can be affected.

Ground the flowmeter and sensor housing.

The line for the supply power must be installed according to the relevant national and international standards. A separate fuse must be connected upstream and in close proximity to each unit. The fuses must be identified accordingly. The unit has a protection class of I and overvoltage class II (IEC664).

The power supply and the electrical circuit for the coils of the sensor are dangerous and pose a contact risk.

The coils and signal circuit can be connected with ABB sensors only. Use the supplied cable.

Only electrical circuits that do not pose a contact risk can be connected to the remaining signal inputs and outputs.

## 1.9 Safety instructions for operation

During operation with hot fluids, contact with the surface may result in burns.

Aggressive fluids may result in corrosion or abrasion of the parts that come into contact with the medium. As a result, pressurized fluids may escape prematurely.

Wear to the flange gasket or process connection gaskets (e.g., aseptic threaded pipe connections, Tri-Clamp, etc.) may enable a pressurized medium to escape.

When using internal flat gaskets, these can become embrittled through CIP/SIP processes.

If pressure shocks exceeding the device's permissible nominal pressure occur continuously during operation, this can have a detrimental effect on the device's service life.



### Warning – Risk to persons!

Bacteria and chemical substances can contaminate or pollute pipeline systems and the materials they are made of.

The appropriate installation conditions must be observed in order to achieve an installation that complies with EHEDG requirements.

For an installation to comply with EHEDG requirements, the process connection/gasket combinations created by the operator must always be made of parts that conform to EHEDG stipulations (EHEDG Position Paper: "Hygienic Process connections to use with hygienic components and equipment").

### 1.10 Technical limit values

The device is designed for use exclusively within the stated values on the name plate and within the technical limit values specified in the data sheets.

The following technical limit values must be observed:

- The permissible operating pressure (PS) in the permissible temperature (TS) may not exceed the pressure-temperature ratings.
- The maximum operating temperature may not be exceeded.
- The permitted operating temperature may not be exceeded.
- The housing protection system must be observed.
- The flowmeter sensor may not be operated in the vicinity of powerful electromagnetic fields, e.g., motors, pumps, transformers, etc. A minimum spacing of approx. 1 m (3.28 ft) should be maintained. For installation on or to steel parts (e.g., steel brackets), a minimum spacing of approx. 100 mm (3.94 inch) should be maintained (based on IEC801-2 and IECTC77B).

### 1.11 Allowed Fluids

When measuring fluids, the following points must be observed:

- Fluids may only be used if, based on state-of-the-art technology or the operating experience of the user, it is assured that chemical and physical properties of the components coming into contact with the fluids (signal electrodes, ground electrodes, liners and, possibly, process connections, protective plates or protective flanges) are not affected during the operating life.
- Fluids with unknown properties or abrasive fluids may only be used if the operator can perform regular and suitable tests to ensure the safe condition of the device.
- Observe the information on the name plate.

### 1.12 Maintenance and inspection safety information



#### Warning – Risk to persons!

When the housing cover is open, EMC and protection against contact are suspended. There are electric circuits within the housing which pose a contact risk. The auxiliary power must be switched off before opening the housing cover.



#### Warning – Risk to persons!

The inspection screw (for draining condensate fluid) for devices  $\geq$  DN 350 can be under pressure. The medium which spurts out can cause severe injuries. Depressurize pipes before opening the inspection screw.

Corrective maintenance work may only be performed by trained personnel.

- Depressurize the device and adjoining lines or containers before removing the device.
- Check whether hazardous materials are used as materials to be measured before opening the device. Residual amounts of hazardous material may still be present in the device and could escape when the device is opened.
- As far as provided in the scope of the operational responsibility, check the following items through a regular inspection:
  - the pressure-carrying walls / lining of the pressure device
  - the measurement-related function
  - the leak tightness
  - the wear (corrosion)

## 2 Transport

### 2.1 Inspection

Check the devices for possible damage that may have occurred during transport. Damages in transit must be recorded on the transport documents. All claims for damages must be claimed without delay against the shipper and before the installation.

### 2.2 General information on transport

Observe the following when transporting the device to the measurement site:

- The center of gravity may not be in the center of the device.
- The protective plates or dust caps mounted at the process connections of devices equipped with PTFE/PFA may only be removed before installation. To prevent possible leakage, make sure that the liner is not cut or damaged.
- Flanged units may not be lifted by the transmitter housing or terminal box.

### 2.3 Transport of flanged units up to nominal diameter DN 300



**Warning – Danger of injuries due to slipping meter.**

The center of gravity of the complete meter may be higher than the lifting straps. Make sure the device has not rotated or slipped unintentionally during transport. Support the meter laterally.

Lifting straps must be used to transport flanged units up to a nominal diameter of DN 300. Wrap the straps around both process connections when lifting the meter. Chains should not be used, since these may damage the housing.

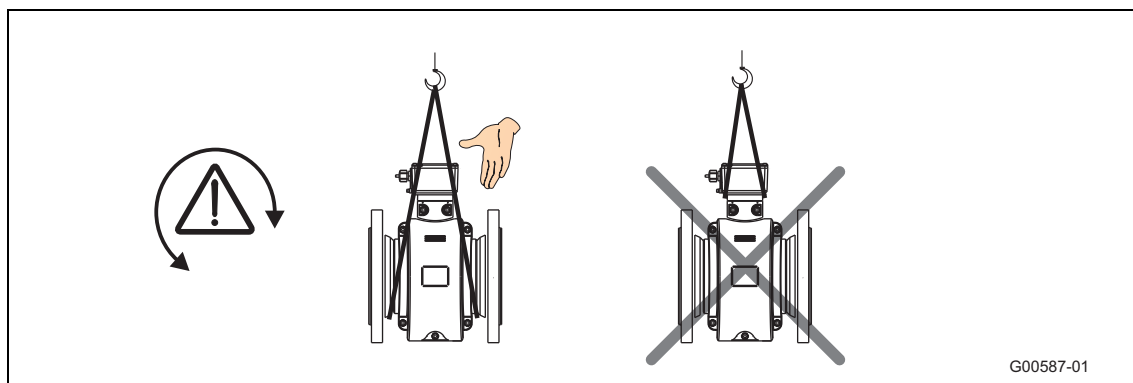

Fig. 1: Transport of flanged units up to nominal diameter DN 300

2.4 Transport of flanged units larger than nominal diameter DN 350



**Notice - Potential damage to parts!**

Use of a forklift to transport the device can dent the housing and damage the internal magnet coils.

Flanged units must not be lifted by the center of the housing when using a forklift for transport.

Flanged units must not be lifted by the terminal box or by the center of the housing. Only the eyebolts fitted to the meter must be used to lift the meter and set it down in the pipeline.

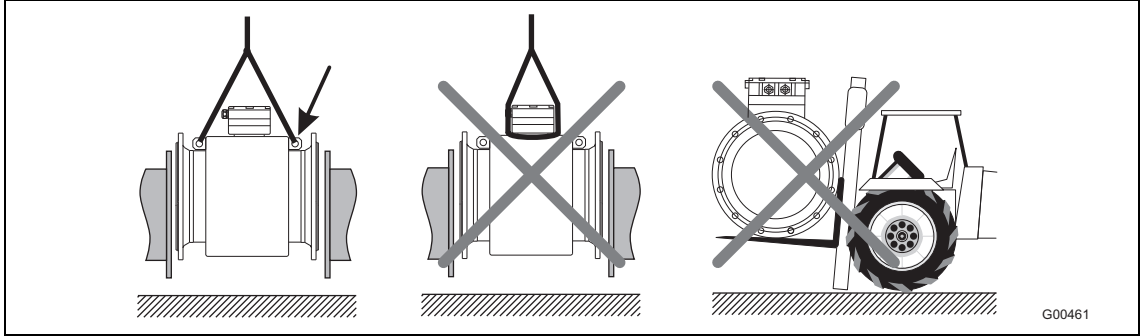

Fig. 2: Transport of flanged units larger than nominal diameter DN 350

### 3 Mounting

#### 3.1 General information on installation

The following points must be observed for the installation:

- The flow direction must correspond to the identification if present.
- The maximum torque for all flange connections must be complied with.
- The devices must be installed without mechanical tension (torsion, bending).
- Install flange and wafer units with coplanar counter flanges and use only appropriate gaskets.
- Use only gaskets made from a compatible material for the fluid and fluid temperature or use only gasket material compatible with hygienic designs.
- Gaskets must not extend into the flow area since possible turbulence could influence the device accuracy.
- The pipeline may not exert any unallowable forces or torques on the device.
- Do not remove the plugs in the cable connectors until you are ready to install the electrical cable.
- Make sure the gaskets for the housing cover are seated properly. Carefully seal the cover. Tighten the cover fittings.
- Install the separate transmitter at a largely vibration-free location.
- Do not expose the transmitter to direct sunlight. Provide appropriate sun protection as necessary.

#### 3.2 Supports for nominal diameters larger than DN 350



##### Notice - Potential damage to parts!

Improper support for the device may result in deformed housing and damage to internal magnet coils.

Place the supports at the edge of the housing (see arrows in the figure).

Devices with a nominal diameter larger than DN 350 must be mounted with support on a sufficiently strong foundation.

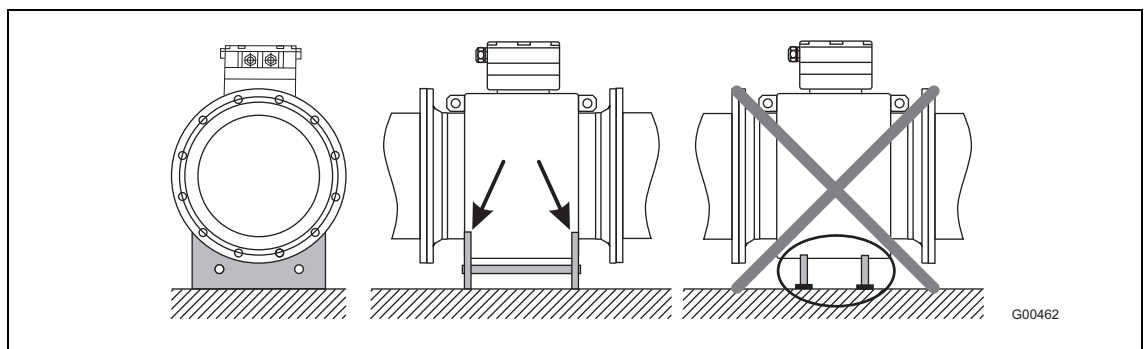

Fig. 3: Support for nominal diameters larger than DN 350

3.3 Mounting the meter tube

The meter can be installed at any location in a pipeline under consideration of the installation conditions.



**Warning - Potential damage to device!**

Use of graphite with the flange or process connection gaskets is prohibited. In some instances, an electrically conductive coating may form on the inside of the measuring tube. Vacuum shocks in the pipelines should be avoided to prevent damage to the liners (PTFE). Vacuum shocks can destroy the meter.

1. Remove protective plates, if present, to the right and left of the measuring tube. To prevent possible leakage, make sure that the liner on the flange is not cut or damaged.
2. Position the meter tube coplanar and centered between the pipes.
3. Install gaskets between the surfaces.



**Important**

- Ideally, flowmeter sensors with PTFE, PFA, or ETFE linings should be installed without gaskets.
  - For best results, make sure the flowmeter sensor gaskets fit concentrically with the meter tube.
4. Use the appropriate screws for the holes as per the section "Torque information".
  5. Slightly grease the threaded nuts.
  6. Tighten the nuts in a crosswise manner as shown in the figure. Observe the torque values specified under "Torques".

First tighten the nuts to 50 % of maximum torque, then to 80 % and finally on the third time tighten to the maximum. Do not exceed the max. torque.

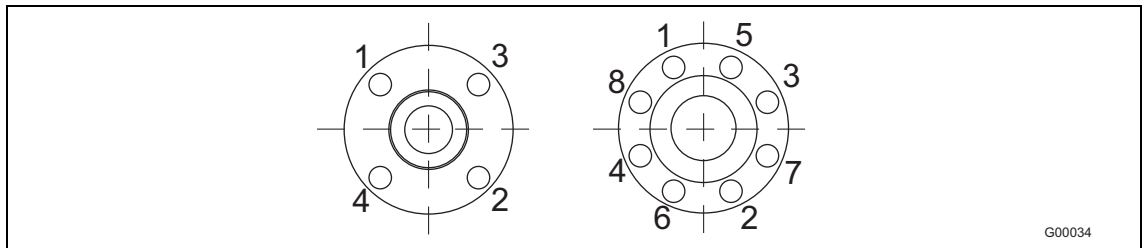

Fig. 4

**3.4 Torque information**
**3.4.1 Flanged units and units with adapter flange, model SE41F / SE21F / SE21W**

Meter size DN		Nominal pressure PN	Max. tightening torque [Nm]			
mm	Inch		Hard/soft rubber lining		PTFE, PFA, ETFE lining	
			Steel flange	Stainless steel flange	Steel flange	Stainless steel flange
3 ... 10 <sup>1)</sup>	1/10 ... 3/8 <sup>1)</sup>	PN40	-	-	12.43	12.43
		PN63/100	-	-	12.43	12.43
		CL150	-	-	12.98	12.98
		CL300	-	-	4.94	17.38
		JIS 10K	-	-	12.43	12.43
15	1/2"	PN40	6.74	4.29	14.68	14.68
		PN63/100	13.19	11.2	22.75	22.75
		CL150	3.65	3.65	12.98	12.98
		CL300	4.94	3.86	4.94	17.38
		CL600	9.73	9.73	-	-
20	3/4"	JIS 10K	2.84	1.37	14.68	14.68
		PN40	9.78	7.27	20.75	20.75
		PN63/100	24.57	20.42	42.15	42.15
		CL150	5.29	5.29	18.49	18.49
		CL300	9.77	9.77	33.28	33.28
25	1"	CL600	15.99	15.99	-	-
		JIS 10K	4.1	1.88	20.75	20.75
		PN40	13.32	8.6	13.32	8.6
		PN63/100	32.09	31.42	53.85	53.85
		CL150	5.04	2.84	23.98	23.98
32	1 1/4"	CL300	17.31	16.42	65.98	38.91
		CL600	22.11	22.11	-	-
		JIS 10K	8.46	5.56	26.94	26.94
		PN40	27.5	15.01	45.08	45.08
		PN63/100	42.85	41.45	74.19	70.07
40	1 1/2"	CL150	4.59	1.98	29.44	29.44
		CL300	25.61	14.22	45.52	45.52
		CL600	34.09	34.09	-	-
		JIS 10K	9.62	4.9	45.08	45.08
		PN40	30.44	23.71	56.06	56.06
		PN63/100	62.04	51.45	97.08	97.08
		CL150	5.82	2.88	36.12	36.12
		CL300	33.3	18.41	73.99	73.99
		CL600	23.08	23.08	-	-
		JIS 10K	12.49	6.85	56.06	56.06

1) Connection flange DIN/EN 1092-1 = DN10 (3/8"), connection flange ASME = DN15 (1/2")

Meter size DN		Nominal pressure PN	Max. tightening torque [Nm]			
mm	Inch		Hard/soft rubber lining		PTFE, PFA, ETFE lining	
			Steel flange	Stainless steel flange	Steel flange	Stainless steel flange
50	2"	PN40	41.26	27.24	71.45	71.45
		PN63	71.62	60.09	109.9	112.6
		CL150	22.33	22.33	66.22	66.22
		CL300	17.4	22.33	38.46	38.46
		CL600	35.03	35.03	-	-
		JIS 10K	17.27	10.47	71.45	71.45
65	2 1/2"	PN16	14.94	8	37.02	39.1
		PN40	30.88	21.11	43.03	44.62
		PN63	57.89	51.5	81.66	75.72
		CL150	30.96	30.96	89.93	89.93
		CL300	38.38	27.04	61.21	61.21
		CL600	53.91	53.91	-	-
80	3"	JIS 10K	14.94	8	37.02	39.1
		PN40	38.3	26.04	51.9	53.59
		PN63	63.15	55.22	64.47	80.57
		CL150	19.46	19.46	104.6	104.6
		CL300	75.54	26.91	75.54	75.54
		CL600	84.63	84.63	-	-
100	4"	JIS 10K	16.26	9.65	45.07	47.16
		PN16	20.7	12.22	49.68	78.19
		PN40	67.77	47.12	78.24	78.19
		PN63	107.4	95.79	148.5	119.2
		CL150	17.41	7.82	76.2	76.2
		CL300	74.9	102.6	102.6	102.6
125	5"	CL600	147.1	147.1	-	-
		JIS 10K	20.7	12.22	49.68	78.19
		PN16	29.12	18.39	61.4	64.14
		PN40	108.5	75.81	123.7	109.6
		PN63	180.3	164.7	242.6	178.2
		CL150	24.96	11.05	98.05	98.05
150	6"	CL300	81.64	139.4	139.4	139.4
		CL600	244.1	244.1	-	-
		PN16	46.99	23.7	81.23	85.08
		PN40	143.5	100.5	162.5	133.5
		PN63	288.7	269.3	371.3	243.4
		CL150	30.67	13.65	111.4	111.4
200	8"	CL300	101.4	58.4	123.6	123.6
		CL600	218.4	218.4	-	-
		PN10	45.57	27.4	113	116.9
		PN16	49.38	33.82	70.42	73
		PN25	100.6	69.17	109.9	112.5
		PN40	196.6	144.4	208.6	136.8
		PN63	350.4	331.8	425.5	282.5
CL150	49.84	23.98	158.1	158.1		
CL300	133.9	78.35	224.3	224.3		

Meter size DN		Nominal pressure PN	Max. tightening torque [Nm]			
mm	Inch		Hard/soft rubber lining		PTFE, PFA, ETFE lining	
			Steel flange	Stainless steel flange	Steel flange	Stainless steel flange
250	10"	PN10	23.54	27.31	86.06	89.17
		PN16	88.48	61.71	99.42	103.1
		PN25	137.4	117.6	166.5	133.9
		PN40	359.6	275.9	279.9	241
		CL150	55.18	27.31	146.1	148.3
		CL300	202.7	113.2	246.4	246.4
300	12"	PN10	58.79	38.45	91.29	94.65
		PN16	122.4	85.64	113.9	114.8
		PN25	180.6	130.2	151.1	106.9
		PN40	On request	On request	On request	On request
		CL150	90.13	50.37	203.5	198
		CL300	333.3	216.4	421.7	259.1
350	14"	PN10	69.62	47.56	72.49	75.22
		PN16	133.6	93.61	124.9	104.4
		PN25	282.3	204.3	226.9	167.9
		CL150	144.8	83.9	270.5	263
		CL300	424.1	252.7	463.9	259.4
		PN10	108.2	75.61	120.1	113.9
400	16"	PN16	189	137.2	191.4	153.8
		PN25	399.4	366	404	246.7
		CL150	177.6	100	229.3	222.8
		CL300	539.5	318.8	635.8	328.1
		CL150	218.6	120.5	267.3	192.3
		CL300	553.8	327.2	660.9	300
450	18"	PN10	141.6	101.4	153.9	103.5
		PN16	319.7	245.4	312.1	224.8
		PN25	481.9	350.5	477.1	286
		CL150	212.5	116	237.3	230.4
		CL300	686.3	411.8	786.8	363.1
		PN10	224.7	164.8	238.7	149.1
600	24"	PN16	515.1	399.9	496.7	365.3
		PN25	826.2	600.3	750.7	539.2
		CL150	356.6	202.8	451.6	305.8
		CL300	1188	719	1376	587.4
		PN10	267.7	204.9	On request	On request
		PN16	455.7	353.2	On request	On request
700	28"	PN25	905.9	709.2	On request	On request
		CL150	364.1	326.2	449.2	432.8
		CL300	1241	On request	On request	On request
		CL150	423.8	380.9	493.3	442
		CL300	1886	On request	On request	On request

Meter size DN		Nominal pressure PN	Max. tightening torque [Nm]			
mm	Inch		Hard/soft rubber lining		ETFE lining	
			Steel flange	Stainless steel flange	Steel flange	Stainless steel flange
800	32"	PN10	391.7	304.2	On request	On request
		PN16	646.4	511.8	On request	On request
		PN25	1358	1087	On request	On request
		CL150	410.8	380.9	493.3	380.9
		CL300	2187	On request	On request	On request
900	36"	PN10	387.7	296.3	On request	On request
		PN16	680.8	537.3	On request	On request
		PN25	1399	1119	On request	On request
		CL150	336.2	394.6	511	458.5
		CL300	1972	On request	On request	On request
1000	40"	PN10	541.3	419.2	On request	On request
		PN16	955.5	756.1	On request	On request
		PN25	2006	1612	On request	On request
		CL150	654.2	598.8	650.6	385.1
		CL300	2181	On request	On request	On request

### 3.4.2 Variable process connections model SE21

Meter size DN		Max. tightening torque
mm	inch	Nm
1 ... 2	1/25 ... 3/32"	PVC/POM: 0,2    Messing/1.4571: 3
3 ... 10	3/8"	8
15	1/2"	10
20	3/4"	21
25	1	31
32	1 1/4"	60
40	1 1/2"	80
50	2	5
65	2 1/2"	5
80	3	15
100	4	14

**3.5 Information on 3A conformity**



**Important**

Only process connections which comply with "3A Sanitary Standard 63" may be used.

The device must only be installed vertically with the terminal box or transmitter housing pointing upward. The "bracket mounting (1)" option no longer applies.

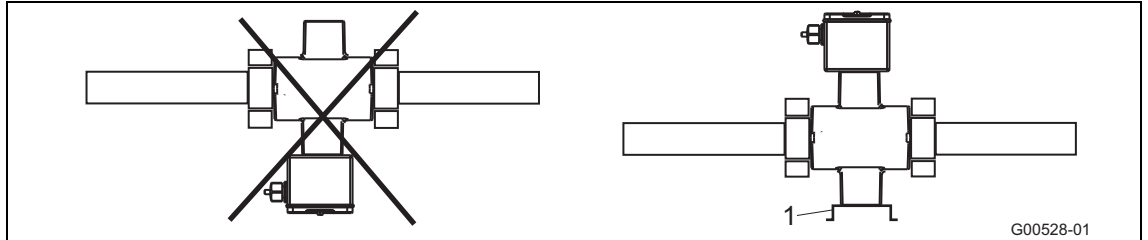

Fig. 5

If concentric reducers are installed on the device, it must be mounted in a vertical position. Refer to the section 3.6.9 "Installation in pipelines with larger nominal diameter".

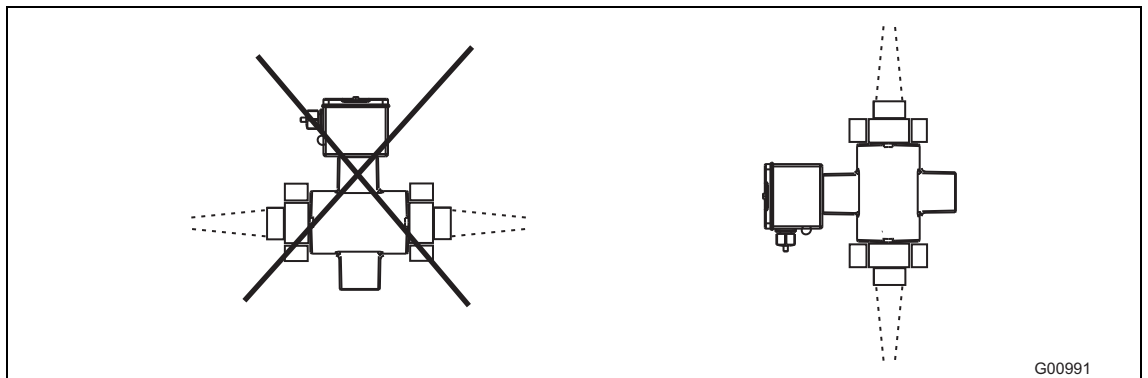

Fig. 6

Please ensure that the leakage hole of the process connection is located at the deepest point of the installed device.

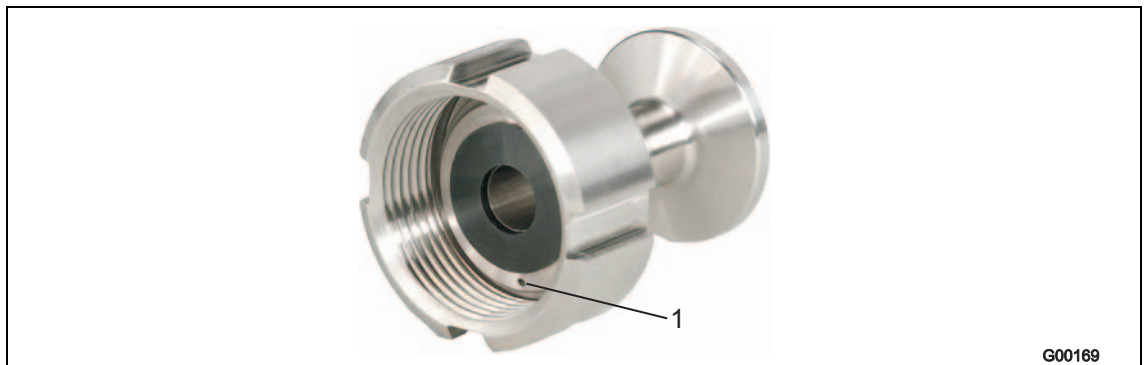

Fig. 7

1 Leakage hole

## Mounting

### 3.6 Installation Requirements

The device measures the flowrate in both directions. Forward flow is the factory setting, as shown in Fig. 8.

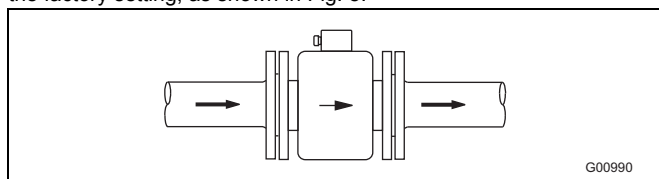

Fig. 8

The following items must be observed:

#### 3.6.1 Electrode axis

Electrode axis (1) as level as possible or rotated max. 45°.

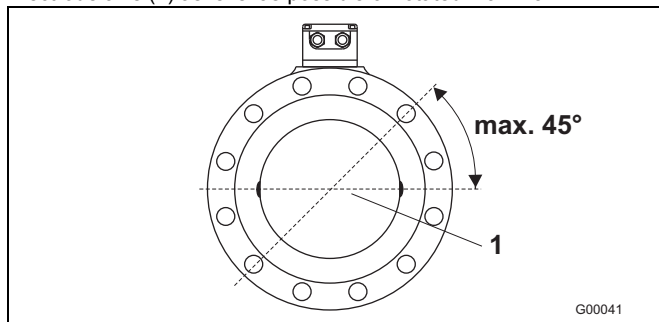

Fig. 9

#### 3.6.2 In- and outlet pipe sections

The metering principle is independent of the flow profile as long as standing eddies do not extend into the metering section, such as may occur after double elbows (1), in the event of tangential inflow, or where half-open gate valves are located upstream of the flowmeter sensor.

In such cases, measures must be put in place to normalize the flow profile.

- Do not install fittings, manifolds, valves, etc., directly in front of the flowmeter sensor (1).
- Butterfly valves must be installed so that the valve plate does not extend into the flowmeter sensor.
- Valves or other turn-off components should be installed in the outlet pipe section (2).

Experience has shown that, in most installations, straight inlet sections 3 x DN long and straight outlet sections 2 x DN long are sufficient (DN = nominal diameter of the sensor Fig. 10 ). For test stands, the reference conditions of 10 x DN straight inlet and 5 x DN straight outlet must be provided, in accordance with EN 29104 / ISO 9104.

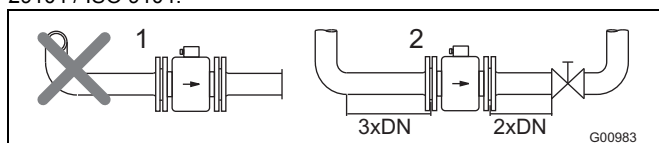

Fig. 10

#### 3.6.3 Vertical connections

- Vertical installation for measuring abrasive fluids, preferably with flow in upward direction.

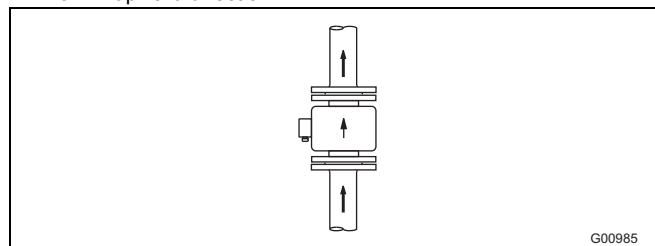

Fig. 11

#### 3.6.4 Horizontal connections

- The measuring tube must always be full.
- Provide for a slight incline of the connection for degassing.

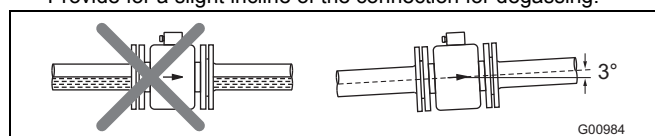

Fig. 12

#### 3.6.5 Free inlet or outlet

- For a free outflow, do not install flowmeter at the highest point in the pipeline, since measuring tube may empty, creating bubbles (1).
- For free inflow/outflow, provide an invert, to ensure that the pipeline is always full (2).

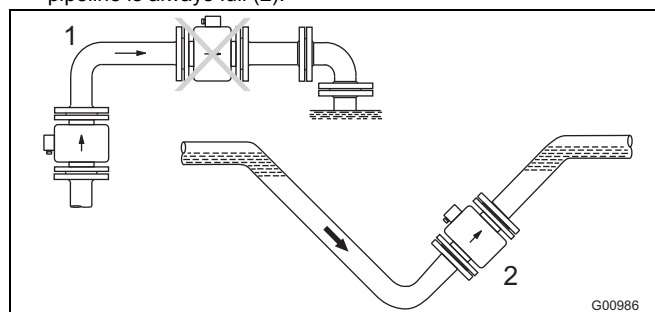

Fig. 13

#### 3.6.6 Strongly contaminated fluids

- For strongly contaminated fluids, a bypass connection according to the figure is recommended so that operation of the system can continue to run without interruption during the mechanical cleaning.

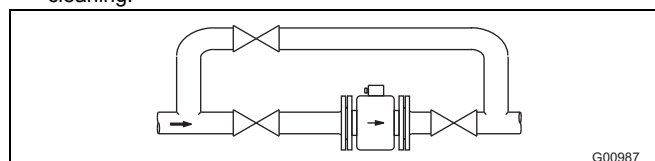

Fig. 14

**3.6.7 Installation in the vicinity of pumps**

- For flowmeter sensors that are installed near pumps or other vibration-causing fixtures, the use of mechanical vibration control components is mandatory.

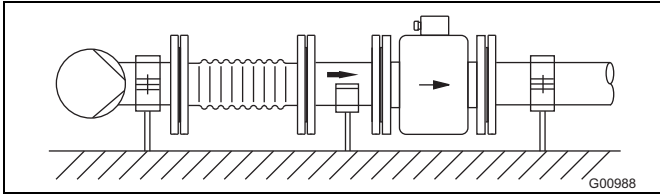

Fig. 15

**3.6.8 Installing the high temperature design**

The high temperature design allows for complete thermal insulation of the sensor. The pipeline and sensor must be insulated after installing the unit according to the following illustration.

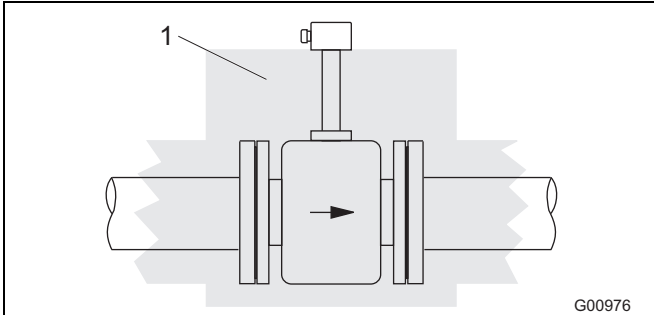

Fig. 16

- 1 Insulation

**3.6.9 Installation in pipelines with larger nominal diameter**

Determine the resulting pressure loss when using reduction pieces (1):

1. Calculate the diameter ratio  $d/D$ .
2. Determine the flow velocity based on the flow range nomograph (Fig. 18).
3. Read the pressure drop on the Y-axis in Fig. 18.

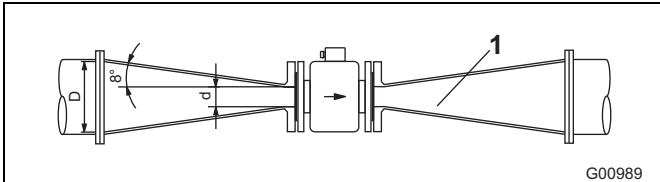

Fig. 17

- d Inside diameter of the flowmeter
- v Flow velocity [m/s]
- $\Delta p$  Pressure loss [mbar]
- D Inside diameter of the pipeline

**Nomograph for pressure drop determinations**

For adaptor with  $\alpha/2 = 8^\circ$

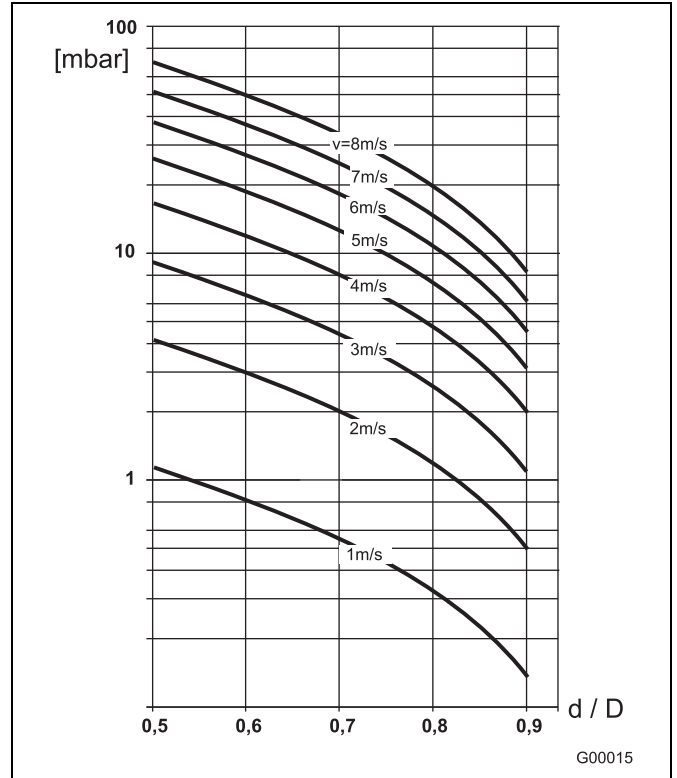

Fig. 18

## Mounting

### 3.7 Ground

#### 3.7.1 General information on ground connections

Observe the following items when grounding the device:

- Use the supplied green-yellow cable as a ground wire.
- Connect the ground screw for the flowmeter sensor (on flange and transmitter housing) to the station ground.
- The connection box must also be grounded.
- For plastic pipes or pipes with insulating lining, the ground is provided by the grounding plate or grounding electrodes.
- When stray potentials are present, install a grounding plate at the front and back of the flowmeter sensor.
- For measurement-related reasons, the potentials in the station ground and in the pipeline should be identical.
- An additional ground via the terminals is not required.



#### Important

If the flowmeter sensor is installed in plastic or earthenware pipelines, or in pipelines with an insulating lining, transient current may flow through the grounding electrode in special cases. In the long term, this may destroy the flowmeter sensor, since the ground electrode will in turn degrade electrochemically. In these special cases, the connection to the ground must be performed using grounding plates.

#### 3.7.2 Metal pipe with fixed flanges

1. Insert M6x12 threads (2) in the flanges for the pipeline and the flowmeter sensor.
2. Secure the ground straps (1) with screw, spring washer, and shim as shown in the figure.
3. Use a copper wire (minimum 2.5 mm<sup>2</sup> (14 AWG)) to establish a connection between the ground connection of the flowmeter sensor and an appropriate grounding point.

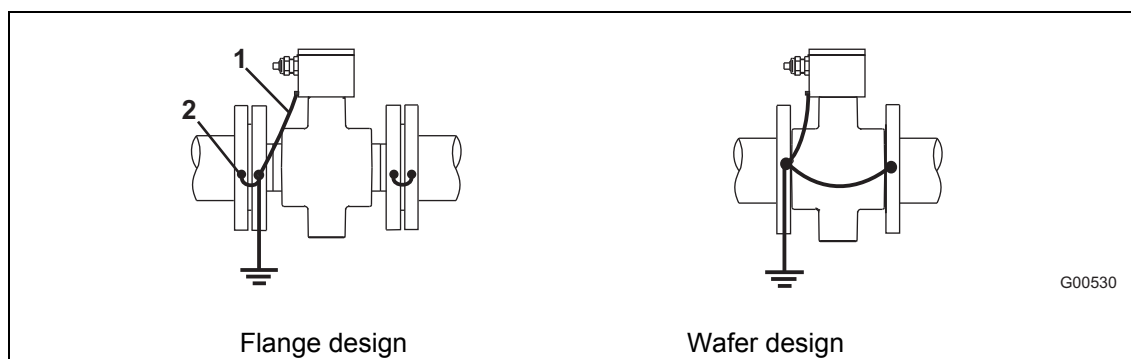

Fig. 19

**3.7.3 Metal pipe with loose flanges**

1. Solder the threaded nuts (2) M6 to the pipeline.
2. Insert M6x12 threads (3) in the flanges for the flowmeter sensor.
3. Secure the ground straps (1) with nut, spring washer, and shim as shown in the figure, and connect to the flowmeter sensor with ground connection (3).
4. Use a copper wire (minimum 2.5 mm<sup>2</sup> (14 AWG)) to establish a connection between the ground connection (3) and an appropriate grounding point.

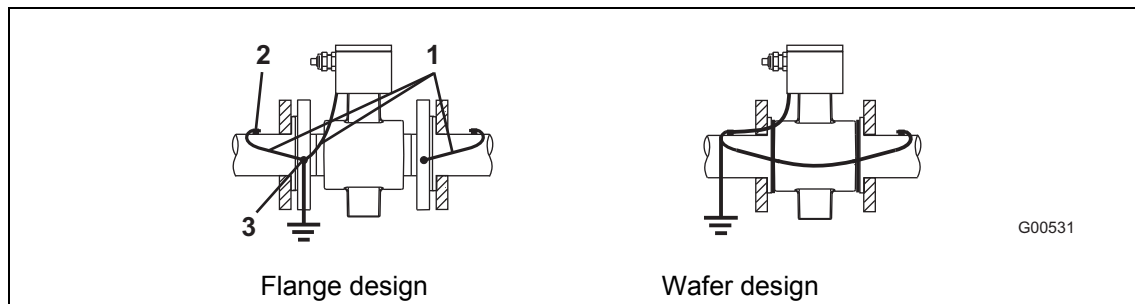

Fig. 20

**3.7.4 Non-metallic pipes or pipes with insulating liner**

For plastic pipes or pipes with insulating lining, the ground for the measuring agent is provided by the grounding plate as shown in the figure below or via grounding electrodes that must be installed in the device (option). If grounding electrodes are used, the grounding plate is not necessary.

1. Install the flowmeter sensor with grounding plate (1) in the pipeline.
2. Insert M6x12 threads (2) in the flange for the flowmeter sensor.
3. Connect the terminal lug for the grounding plate (3) and the ground connection on the flowmeter sensor (2) with the grounding strap.
4. Use a copper wire (minimum 2.5 mm<sup>2</sup> (14 AWG)) to establish a connection between the ground connection (2) and a good grounding point.

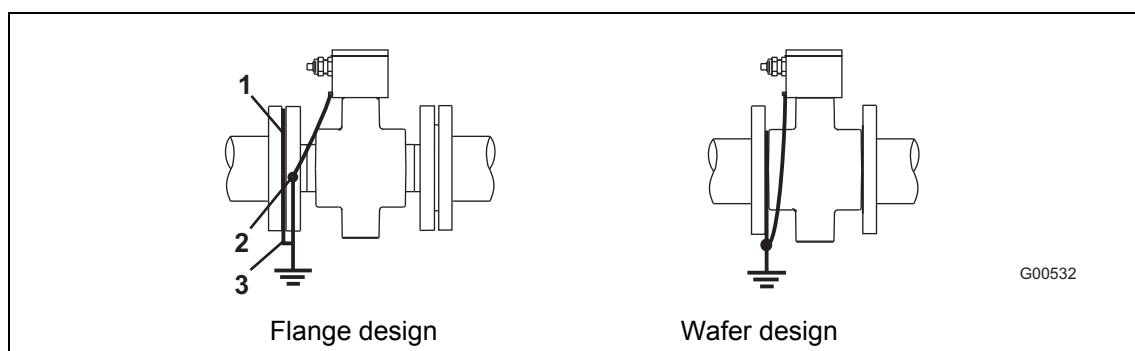

Fig. 21

### 3.7.5 Flowmeter sensor in stainless steel design model SE21

Ground the stainless steel model as shown in the figure. The measuring fluid is grounded via the adapter (1) and an additional ground is not required.

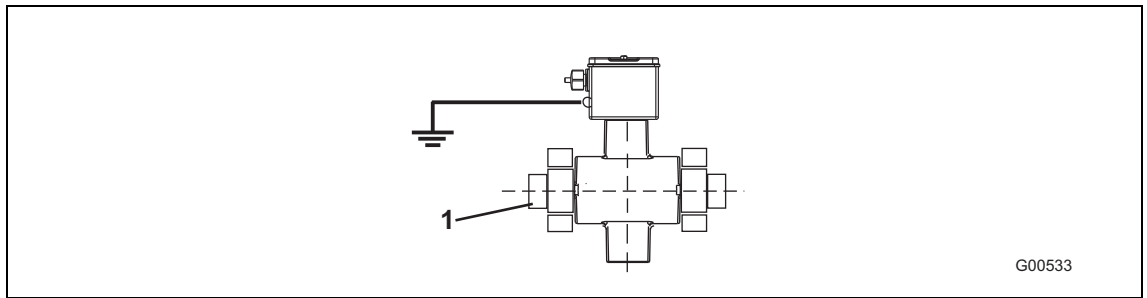

Fig. 22

### 3.7.6 Ground for devices with protective plates

The protective plates are used to protect the edges of the liner in the measuring tube, e.g., for abrasive fluids. In addition, they function as a grounding plate.

- For plastic or pipes with insulating lining, electrically connect the protective plate in the same manner as a grounding plate.

### 3.7.7 Ground with conductive PTFE grounding plate

For devices with a meter size between DN 10 ... 250, grounding plates made of conductive PTFE are available. These are installed in a similar way to conventional grounding plates.

**4 Electrical connections**

**4.1 Preparing and routing the signal and magnet coil cable**

Cut to length and terminate both cables as shown.



**Important**  
Use wire end sleeves.

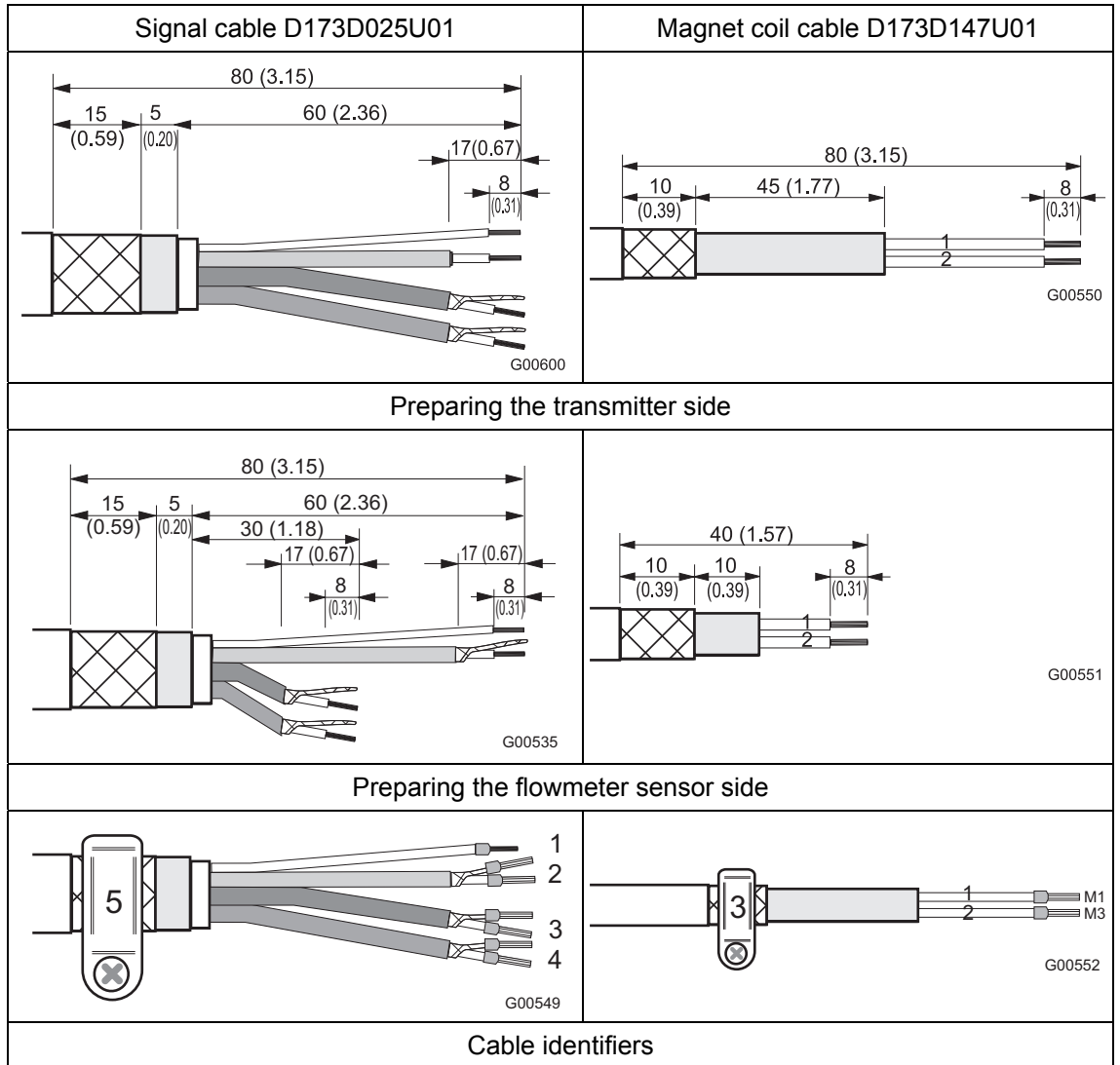

Fig. 23: Dimensions in mm (inch)

- |                                 |                      |
|---------------------------------|----------------------|
| 1 Measurement potential, yellow | 1 Magnet coil, black |
| 2 Reference, white              | 2 Magnet coil, black |
| 3 Signal cable, red             | 3 SE clamp           |
| 4 Signal cable, blue            |                      |
| 5 SE clamp                      |                      |



**Important**  
The shields may not touch (signal short circuit).

Observe the following items when routing cables:

- The signal and magnet coil cable carries a voltage signal of only a few millivolts and therefore must be routed the shortest distance possible. The maximum permissible signal cable length is 50 m or 200 m, if the flowmeter sensor is equipped with a preamplifier.
- Avoid routing the cable in the vicinity of electrical equipment or switching elements that can create stray fields, switching pulses and induction. If this is not possible, run the signal/magnet coil cable through a metal pipe and connect this to the station ground.
- All leads must be shielded and connected to station ground.
- Do not run the signal cable and the magnet coil cable over junction boxes or terminal blocks.
- To shield against magnetic interspersion, the cable contains outer shielding that is attached to the SE clamp.
- Make sure during installation that the cable is provided with a water trap (1). For vertical installation, align the cable glands pointing downward.

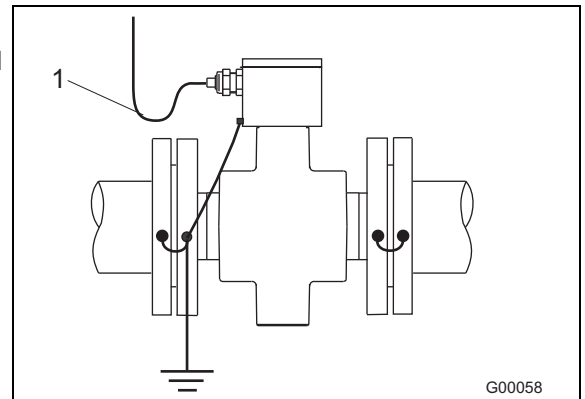

Fig. 24

## i

### Important

For information about connecting or operating older models, refer to chapter 11 of the operating instructions.

**4.2 Connecting the flowmeter sensor**

**4.2.1 Connecting the signal and magnet coil cables**

The flowmeter sensor is connected to the transmitter via the signal / magnet coil cables (part no. D173D025U01 / D173D147U01). The coils of the flowmeter sensor are supplied with a field voltage by the transmitter over terminals M1/M3. Connect the cables to the flowmeter sensor according to the following drawing, using a screwdriver with proper size and width.

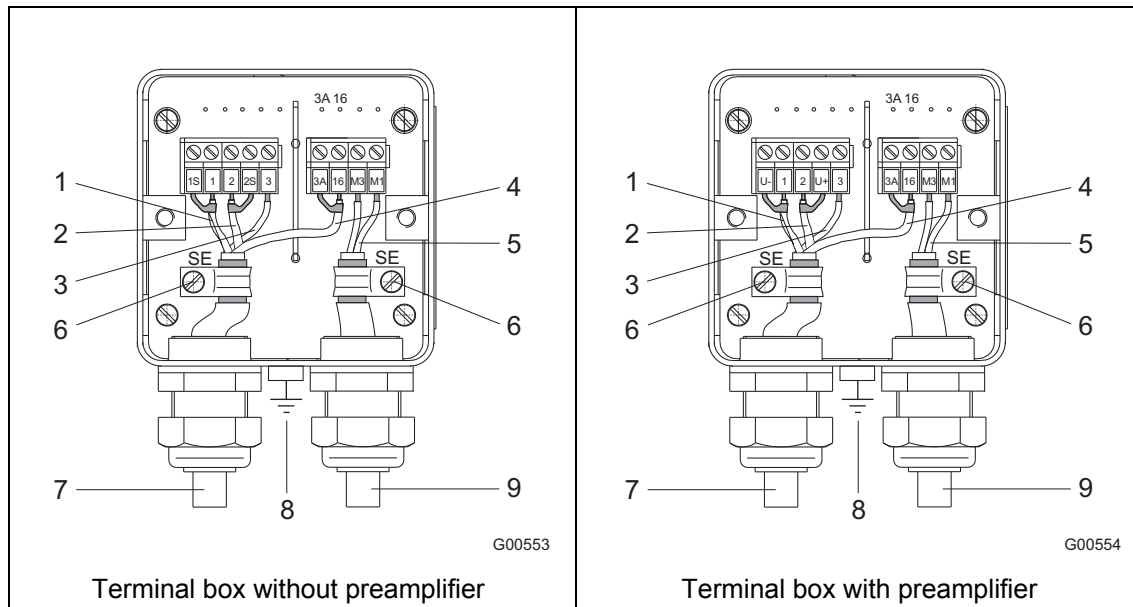

Fig. 25

- 1 red
- 2 blue
- 3 yellow
- 4 white
- 5 black
- 6 SE clamp
- 7 Signal cable
- 8 Grounding screw
- 9 Magnet coil cable

- 1 red
- 2 blue
- 3 yellow
- 4 white
- 5 black
- 6 SE clamp
- 7 Signal cable
- 8 Grounding screw
- 9 Magnet coil cable

Terminal designation	Connection
1 + 2	Wires for the measuring signal
1S, 2S	Shielding for signal wires
U+, U-	Power supply for preamplifier via signal cable shielding
16	Cable for reference signal
3A	Shielding for reference signal cable
3	Measuring ground (yellow)
M1 + M3	Connections for magnetic field excitation (black)
SE	Outer cable shield

#### 4.2.2 Protection class IP 68

For flowmeter sensors with IP 68 degree of protection, the maximum flooding height is 5 m (16.4 ft). The supplied cable (signal cable part no. D173D025U01 / magnet coil cable part no.: D173D147U01) fulfill the submersion requirements.

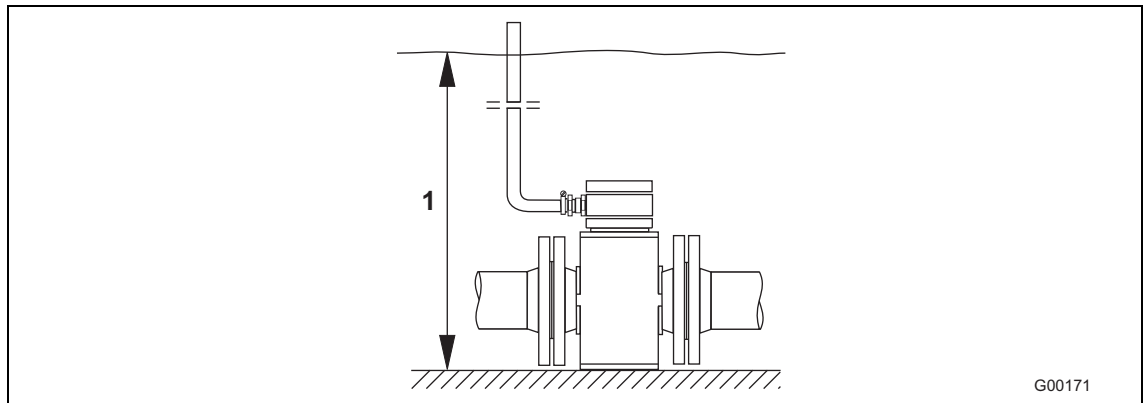

Fig. 26

- 1 Max. flooding height 5 m (16,4 ft)

The flowmeter sensor is type-tested in accordance with EN 60529. Test conditions: 14 days at a flooding height of 5 m (16.4 ft).

##### 4.2.2.1 Connection

1. Use the supplied cable to connect the flowmeter sensor and the transmitter.
2. Connect the signal cable in the terminal box of the sensor.
3. Route the cable from the terminal box to above the maximum flooding height of 5 m (16.4 ft).
4. Tighten the cable gland.
5. Carefully seal the terminal box. Make sure the gaskets for the cover are seated properly.



#### Warning - Potentially adverse effect on IP 68 protection class

The sensor's IP 68 protection class may be impaired by damage to the signal cable. The sheathing of the signal cable must not be damaged. Otherwise, the protection class IP 68 for the sensor cannot be ensured.



#### Important

As an option, the flowmeter sensor can be ordered with signal cable already connected and a molded terminal box.

4.2.2.2 Sealing the connection box

If the terminal box is to be sealed subsequently on-site, a special 2-part sealing compound can be ordered separately (order no. D141B038U01). Sealing is only possible if the flowmeter sensor is installed horizontally.

Observe the following instructions during work activity:



**Warning - General risks!**

The sealing compound is toxic. Observe all relevant safety measures.

Risk notes: R20, R36/37/38, R42/43

Harmful by inhalation. Avoid direct skin contact. Irritating to eyes.

Safety advice: P4, S23-A, S24/25, S26, S37, S38

Wear suitable protective gloves and ensure sufficient ventilation.

Follow the instructions that are provided by the manufacturer prior to starting any preparations.

**Preparation**

- Complete the installation before beginning sealing activities in order avoid moisture penetration. Before starting, check all the connections for correct fitting and stability.
- Do not overfill the terminal box. Keep the sealing compound away from the O-ring and the seal/groove (see Fig. 27).
- Prevent the sealing compound from penetrating a thermowell if an NPT ½" thread is used.

**Procedure**

1. Cut open the protective enclosure of the sealing compound (see packaging).
2. Open the connection clamp between the hardener and the sealing compound.
3. Knead both components thoroughly until a good mix is reached.
4. Cut open the bag at a corner. Perform work activity within 30 minutes.
5. Carefully fill the terminal box with sealing compound until the connecting cable is covered.
6. Wait a few hours before closing the cover in order to allow the compound to dry, and to release any possible gas.
7. Ensure that the packaging material and the drying bag are disposed of in an environmentally sound manner.

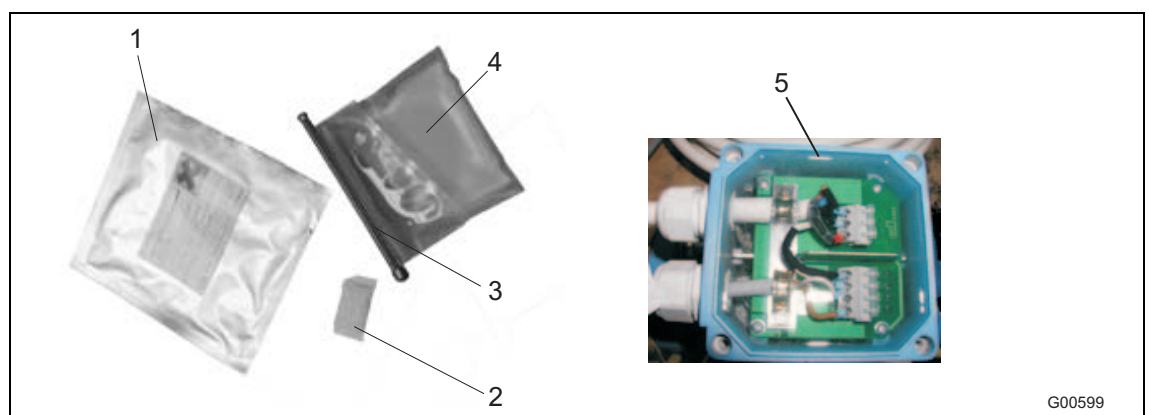

Fig. 27

- |                 |                    |
|-----------------|--------------------|
| 1 Packaging bag | 4 Sealing compound |
| 2 Drying bag    | 5 Filling height   |
| 3 Clamp         |                    |

## Electrical connections

### 4.3 Terminal connection diagrams

Standard DN 10 ... DN 1000 (3/8 ... 40")

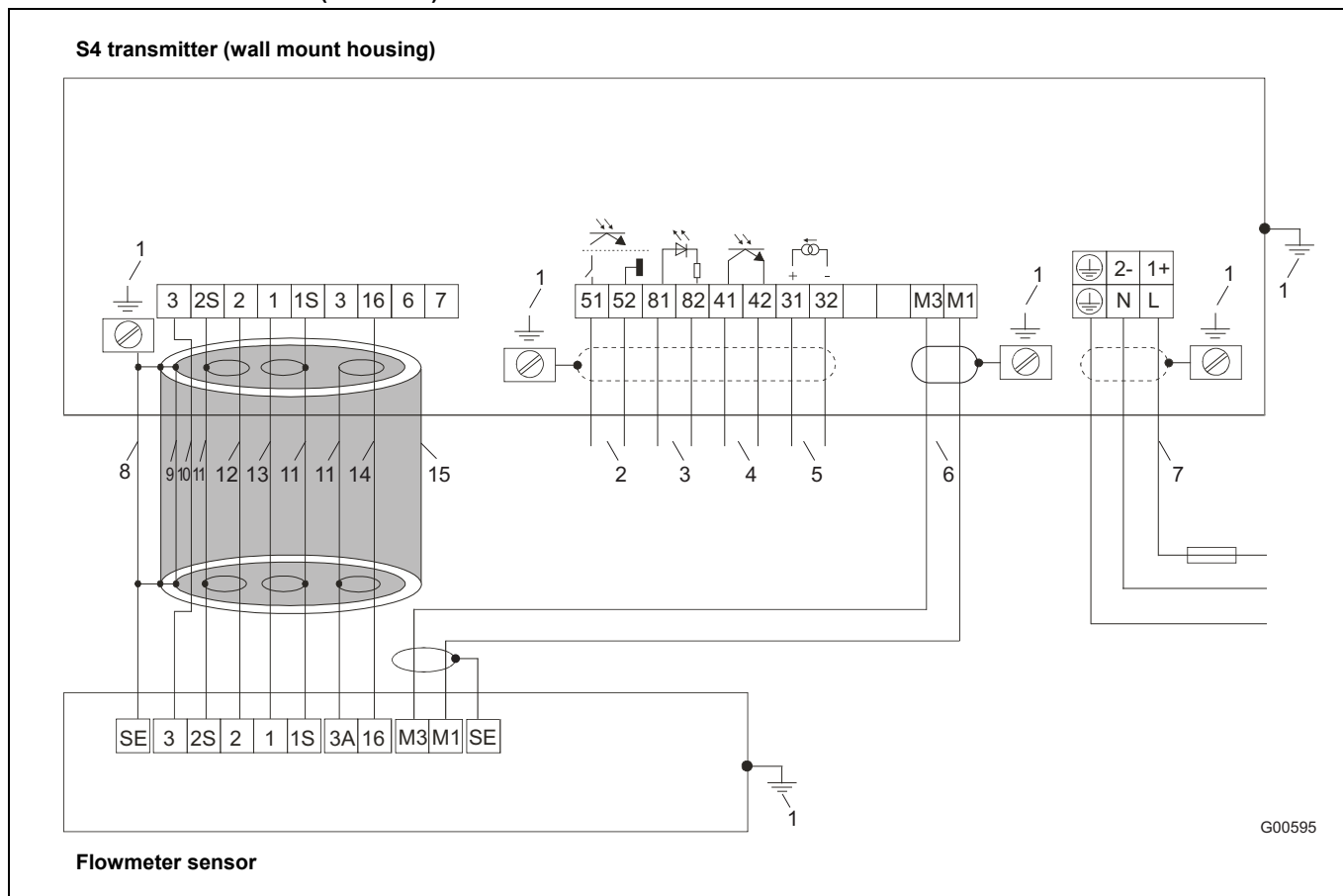

Fig. 28: Connection diagram: Flowmeter sensor standard DN 10 ... DN 1000 (3/8 ... 40")

- |  |  |
|--|--|
| 1 Functional ground (busbar)   | 8 Steel shielding  |
| 2 Pulse output <sup>1)</sup>   | 9 Aluminum foil  |
| 3 Contact input <sup>1)</sup>  | 10 Yellow  |
| 4 Contact output <sup>1)</sup>   | 11 Shield  |
| 5 Current output <sup>1)</sup>   | 12 Blue  |
| 6 Magnet coil cable:<br>shielded 2 x 1 mm <sup>2</sup> CE Typ 227 TEC 74<br>ABB order no. D173D147U01, 10 m included in shipment,<br>standard  | 13 Red   |
| 7 Supply power<br>Low voltage: 100 ... 230 V AC, terminals L, N, ⊕<br>Low voltage: 20.4 ... 26.4 V AC;<br>20.4 ... 31.2 V DC<br>Terminals 1+, 2-, ⊕<br>Frequency: 47 Hz ≤ f ≤ 53 Hz; 50 Hz supply power<br>56 Hz ≤ f ≤ 64 Hz; 60 Hz supply power | 14 White   |
|  | 15 Shielded signal cable: ABB order no. D173D025U01, 10 m included in shipment |

1) See the section "Connection examples for peripherals" in the operating instructions and/or on the data sheet

#### Comment:

We recommend that shielded output cables be used with the shields connected to the functional ground at one end.

with preamplifier DN 1 ... DN 1000 (1/25 ... 40")

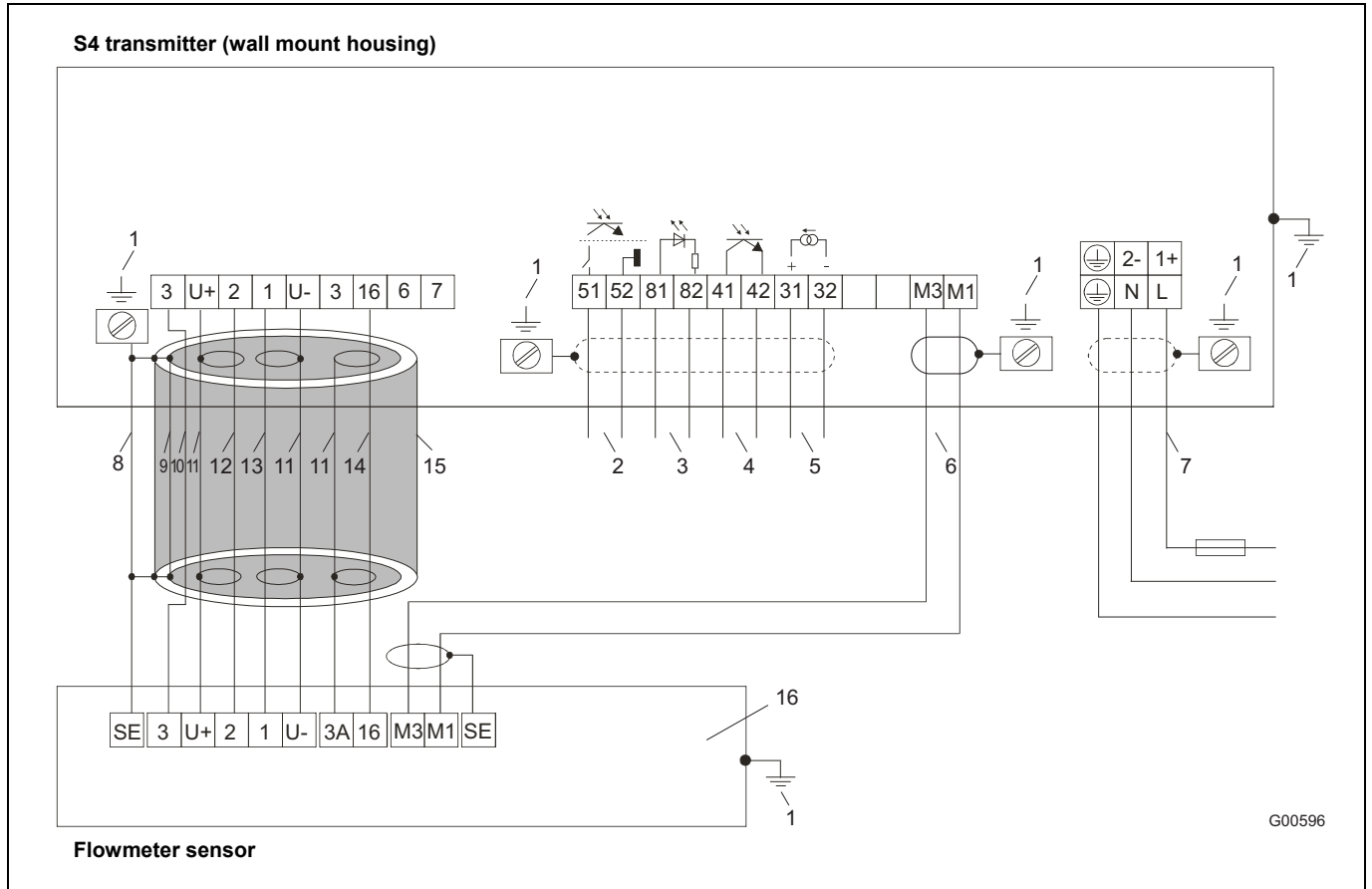

Fig. 29: Connection diagram: Flowmeter sensor with preamplifier DN 1 ... DN 1000 (1/25 ... 40"), transmitter field-mount housing

- |   |  |
|---|--|
| 1 Functional ground (busbar)  | 8 Steel shielding  |
| 2 Pulse output <sup>1)</sup>  | 9 Aluminum foil  |
| 3 Contact input <sup>1)</sup>   | 10 Yellow  |
| 4 Contact output <sup>1)</sup>  | 11 Shield  |
| 5 Current output <sup>1)</sup>  | 12 Blue  |
| 6 Magnet coil cable:<br>shielded 2 x 1 mm <sup>2</sup> CE Typ 227 TEC 74<br>ABB order no. D173D147U01, 10 m included in shipment,<br>standard       | 13 Red   |
| 7 Supply power<br>Low voltage: 100 ... 230 V AC, terminals L, N, ⊕<br>Low voltage: 20.4 ... 26.4 V AC;<br>20.4 ... 31.2 V DC<br>Terminals 1+, 2-, ⊕ | 14 White   |
| Frequency: 47 Hz ≤ f ≤ 53 Hz; 50 Hz supply power<br>56 Hz ≤ f ≤ 64 Hz; 60 Hz supply power   | 15 Shielded signal cable: ABB order no. D173D025U01,<br>10 m, included in shipment |
|   | 16 With preamplifier (always with DN 1 ... DN 8 [1/25 ... 5/16"])                  |

1) See the section "Connection examples for peripherals" in the operating instructions and/or on the data sheet

**Comment:**

We recommend that shielded output cables be used with the shields connected to the functional ground at one end.



**Important**

If the flowmeter sensor is equipped with a preamplifier for low conductivity or in nominal diameter DN 1 ... DN 8 (1/25 ... 5/16"), the shieldings of the signal wires must be connected to terminals U+ and U- on both the flowmeter sensor and the transmitter.



**Important**

For information about potential upgrades for models 10D1422, 10D1425 and 10DS3111A-E, refer to the chapter "Connection diagrams" in the operating instructions.

## Electrical connections

### DN 1 ... DN 1000 (1/25 ... 40") with PROFIBUS PA / FOUNDATION Fieldbus

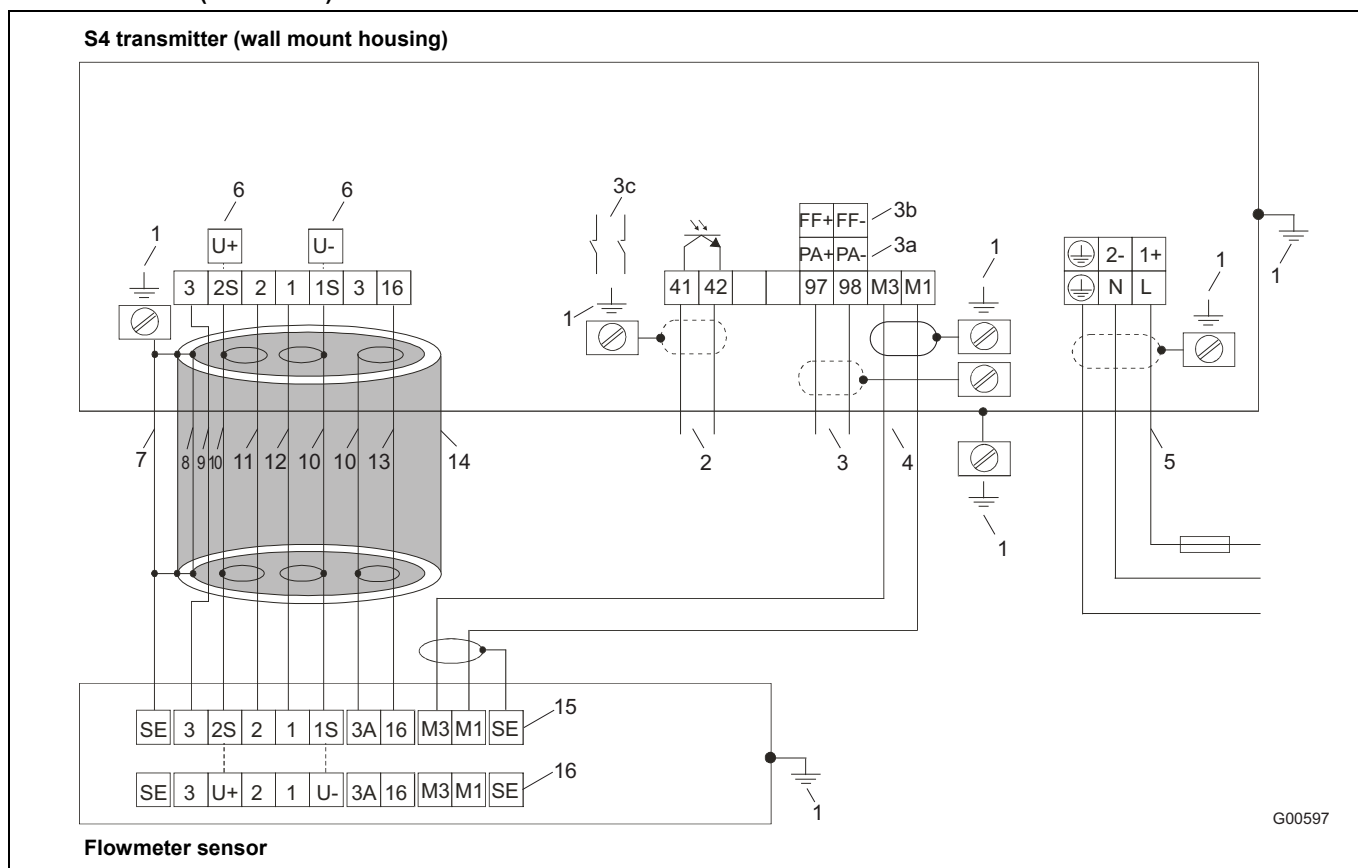

Fig. 30: Connection diagram: transmitter SF with PROFIBUS PA / FOUNDATION Fieldbus

- |  |   |
|--|---|
| <p>1 Functional ground (busbar)</p> <p>2 Contact output (see the section "Connection examples for peripherals" in the operating instructions and/or on the data sheet)</p> <p>3 Digital communication<br/> 3a: PROFIBUS PA design according to IEC 61158-2 (Profile 3.0)<br/> U = 9 ... 32 V, I = 10 mA (normal operation)<br/> I = 13 mA (in the event of error/FDE)<br/> Terminals: 97/98, PA+/PA-<br/> (see the section "Connecting via M12 plug" in the operating instructions and/or on the data sheet)<br/> 3b: FOUNDATION Fieldbus design conforming to IEC 61158-2<br/> U = 9 ... 32 V, I = 10 mA (normal operation)<br/> I = 13 mA (in the event of error/FDE)<br/> Terminals: 97/98, FF+/FF-<br/> (see the section "Connecting via M12 plug" in the operating instructions and/or on the data sheet)<br/> 3c: Bus termination with installed bus termination components with hook switches closed</p> <p>4 Magnet coil cable:<br/> shielded 2 x 1 mm<sup>2</sup> CE Typ 227 TEC 74<br/> ABB order no. D173D147U01, 10 m included in shipment, standard</p> | <p>5 Supply power<br/> Low voltage: 100 ... 230 V AC, terminals L, N, ⊕<br/> Low voltage: 20.4 ... 26.4 V AC;<br/> 20.4 ... 31.2 V DC<br/> Terminals 1+, 2-, ⊕<br/> Frequency: 47 Hz ≤ f ≤ 53 Hz; 50 Hz supply power<br/> 56 Hz ≤ f ≤ 64 Hz; 60 Hz supply power</p> <p>6 Shielded signal cable:<br/> Power supply for flowmeter sensor with preamplifier<br/> Terminals U+, U- instead of 2S and 1S in standard unit</p> <p>7 Steel shielding</p> <p>8 Aluminum foil</p> <p>9 Yellow</p> <p>10 Shield</p> <p>11 Blue</p> <p>12 Red</p> <p>13 White</p> <p>14 Shielded signal cable: ABB order no. D173D025U01, 10 m, included in shipment</p> <p>15 Without preamplifier</p> <p>16 With preamplifier (always with DN 1 ... DN 8 [1/25 ... 5/16"])</p> |
|--|---|

#### Comment:

We recommend that shielded output cables be used with the shields connected to the functional ground at one end.



#### Important

If the flowmeter sensor is equipped with a preamplifier for low conductivity or in nominal diameter DN 1 ... DN 8 (1/25 ... 5/16"), the shieldings of the signal wires must be connected to terminals U+ and U- on both the flowmeter sensor and the transmitter.

**4.4 Connection examples for peripherals (incl. HART)**

**Current output**

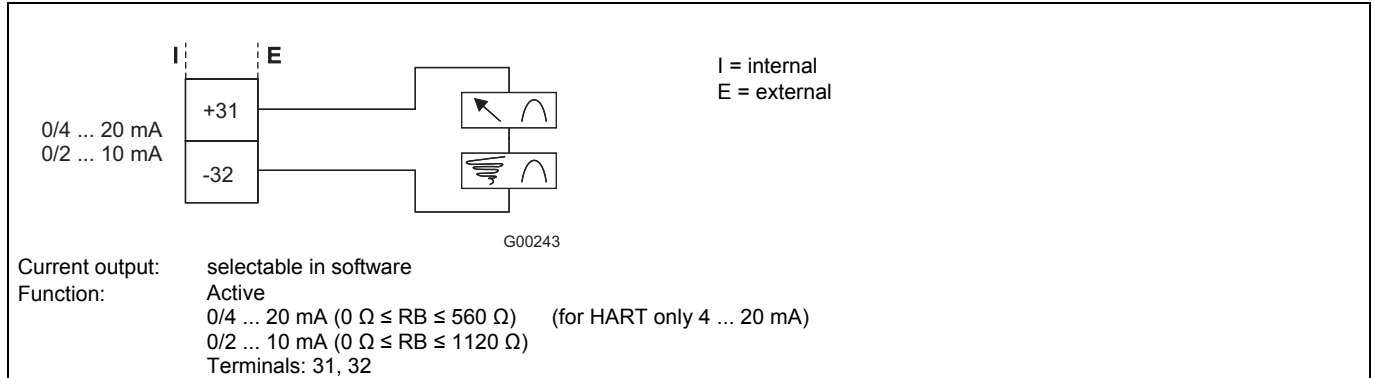

Fig. 31: Current output active with/without HART protocol (4 ... 20 mA)

**Contact output**

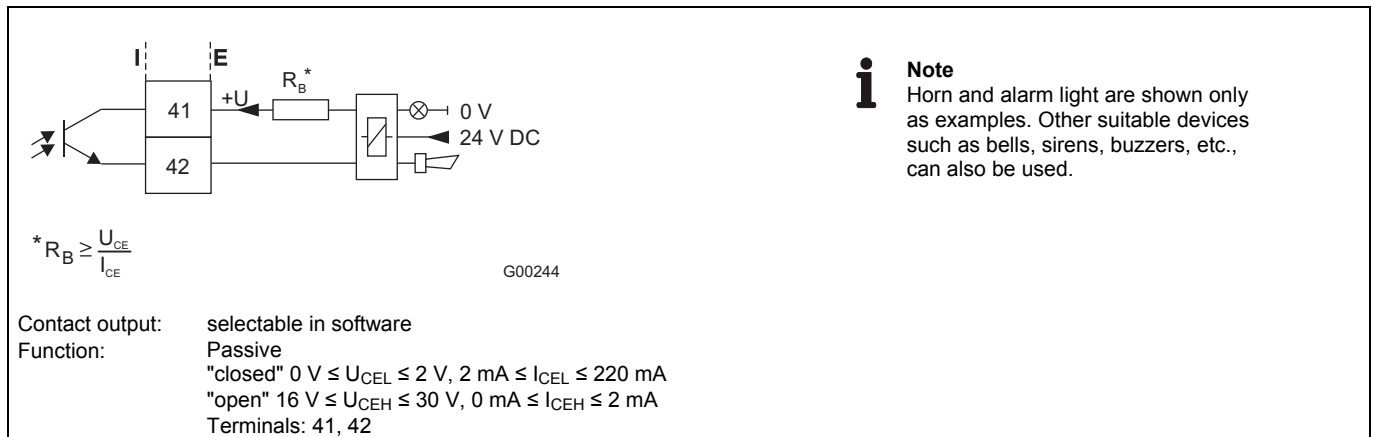

Fig. 32: Contact output for system monitoring, Max.-Min. alarm for empty tube or forward/reverse signal

**Contact input**

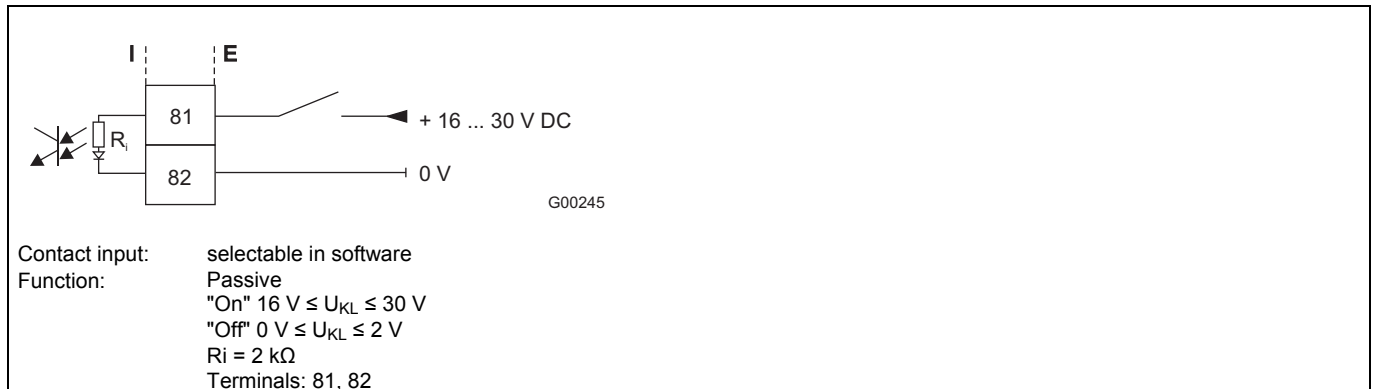

Fig. 33: Contact input for external totalizer reset and external zero return

Pulse output

**Pulse output active**

G00598

**Pulse output, passive, optocoupler**

G00247

\*  $R_B \geq \frac{U_{CE}}{I_{CE}}$

Function: active/passive, selectable via jumper (see "Commissioning" in operating instructions)

fmax: 5 kHz,

fmin: 0.00016 Hz

Setting range: Pulses/unit, pulse width (observe dynamic limits)

Active: 150 Ω ≤ Load < 10 kΩ Pulse width ≤ 50 ms, max. pulse frequency ≤ 3 Hz,  
 500 Ω ≤ Load < 10 kΩ Pulse width ≥ 0.1 ms, max. pulse frequency: 5 kHz

Passive: "closed": 0 V ≤ U<sub>CEL</sub> ≤ 2 V, 2 mA ≤ I<sub>CEL</sub> ≤ 220 mA  
 "open": 16 V ≤ U<sub>CEH</sub> ≤ 30 V, 0 mA ≤ I<sub>CEH</sub> ≤ 2 mA

Terminals: 51, 52

Fig. 34: Pulse output, active and passive, optocoupler

PROFIBUS PA / FOUNDATION Fieldbus

G00248

The resistance R and condenser C form the bus termination. They must be installed when the device is connected to the end of the entire bus cable.

R = 100 Ω; C = 1 μF

1 PROFIBUS PA  
 2 FOUNDATION Fieldbus

I = Internal  
 E = external

Fig. 35

Bus termination for S4 transmitter

To terminate the bus if the instrument is at the end of the bus cable, the termination components in the S4 transmitter can be used. To do so, close both hook switches in the connection area of the transmitter.



**Important**

If the transmitter module is removed, bus termination is also canceled.

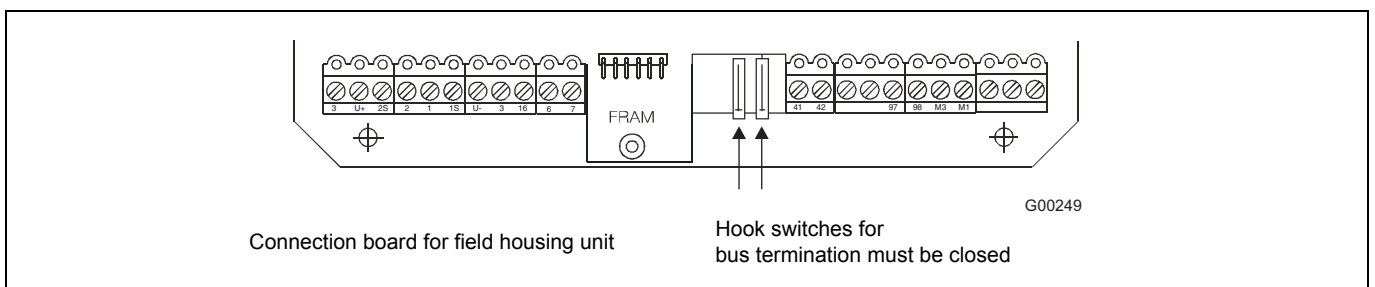

Fig. 36

**5 Commissioning**

**5.1 Preliminary checks prior to start-up**

The following points must be checked before commissioning:

- The supply power must be switched off.
- The supply power must match information on the name plate.
- The pin assignment must correspond to the connection diagram.
- Sensor and transmitter must be grounded properly.
- The temperature limits must be observed.
- When the sensor (SE41F, SE21, SE21F) and transmitter (S4) are delivered as a pair, the data memory module (external FRAM) is located in the sensor. The data module stores the sensor data, e.g., size, Cs, Cz, type, etc., as well as the setup data on the transmitter after commissioning.
- Prior to commissioning, plug the external FRAM for the appropriate sensor (order no. is printed on the FRAM and, if available, a TAG no.) to the connection board for the installed transmitter. Then screw to the connection board (captive).

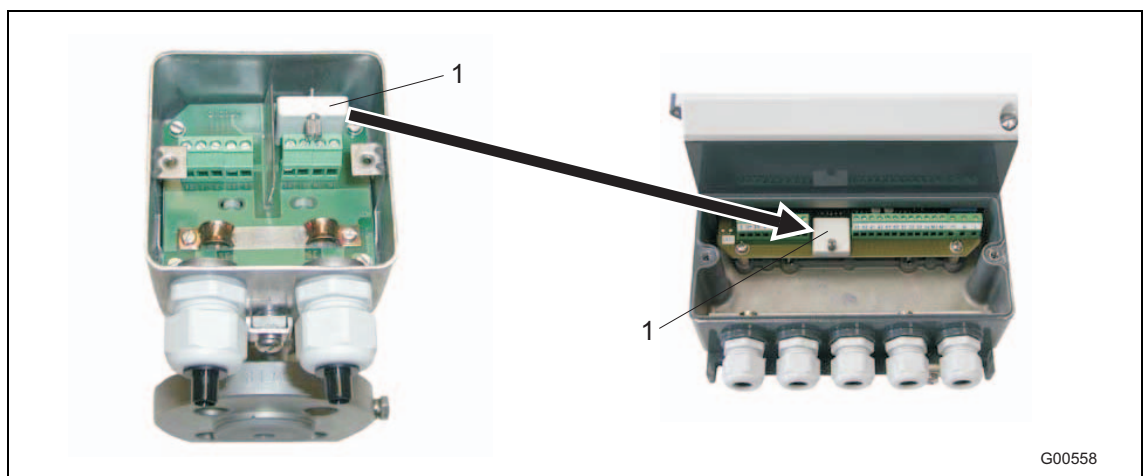

Fig. 37

1 External FRAM

**i**

**Important**

If a transmitter is ordered for an older model sensor (see model number), an external FRAM is already connected to the connection board. You will also find the information Cs = 100% and Cz = 0%, which is required for sensors from older product lines. See also chapter 11 "Supplementary information: Operating S4 with an older model" in the operating instructions.

- The sensor must be installed at a largely vibration-free location.
- The sensor and the converter must be assigned properly for the model FSM4000: The sensors have an end number of X1, X2, etc., on the name plate. The transmitters have the end numbers Y1, Y2, etc. End numbers X1 and Y1 are considered a unit.
- Monitoring of pulse output.

The pulse output can be operated as active output (24 VDC pulse) or as passive output (optocoupler). The current setting is provided on the name plate for the transmitter. Modification as shown in the following illustration.

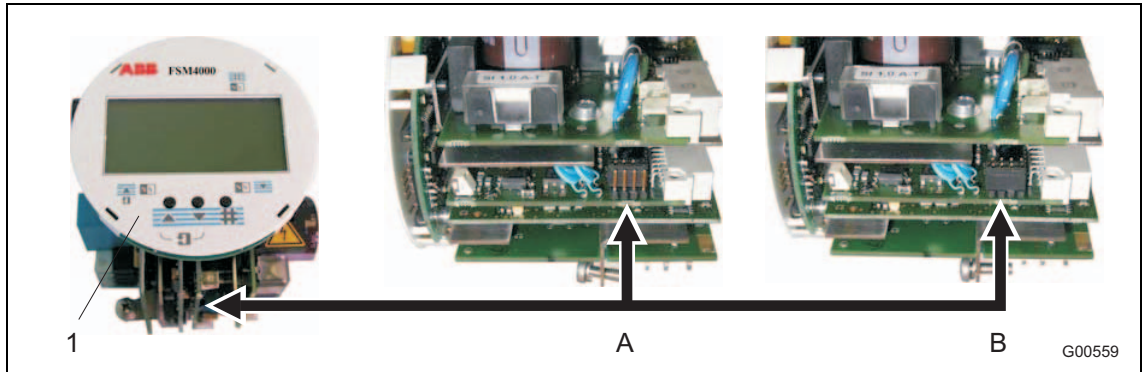

Fig. 38: Setting the pulse output using jumpers

1 Display board

A Pulse passive (jumper inner)

B Pulse active (jumper outer)

The transmitter is immediately ready for operation after mounting and installation of the connections. The parameters are set at the factory.

The connected lines must be checked for firm seating. Only firmly seated lines ensure full functionality.

### 5.1.1 Switching on supply power

After switching on the supply power, the flowmeter sensor data in the external FRAM is compared with the data saved internally. If the data is not identical, the transmitter data is replaced automatically. Once completed, Warning 7 "Flowmeter sensor data loaded" and Warning 8b "Update external FRAM" are displayed. The measuring equipment is now ready for operation.

The display shows the current flowrate.



#### Important

For information about menu navigation for the device, refer to the the "Parameterization" section of the operating instructions.

## 5.2 Commissioning PROFIBUS PA units

For units with PROFIBUS PA, the bus address must be checked or configured prior to start-up. If no bus address information was supplied by the customer, the unit was shipped with its BUS address set to "126".

The address must be reset during start-up to a number within the valid range (0 ... 125).



### Important

The address selected may only appear once in the segment.

The address can be set either locally on the unit (via the DIP switches on the digital board), using system tools, or via a PROFIBUS DP master class 2 such as Asset Vision Basic (DAT200).

The factory setting for DIP switch 8 is OFF, i.e. the address is set using the fieldbus. The front cover can be unscrewed to change the settings. It is also possible to set the address via menu by using the keys on the display board.

The PROFIBUS PA interface conforms with Profile 3.0 (fieldbus standard PROFIBUS, EN 50170, DIN 19245 [PRO91]). The transmitter transmission signal is designed according to IEC 61158-2.



### Important

The manufacturer-specific PROFIBUS PA ID no. is: 0x078C hex.

The unit can also be operated with the PROFIBUS standard ID nos. 0x 9700 or 0x9740.

Example of local address setting (DIP switch 8 = On)

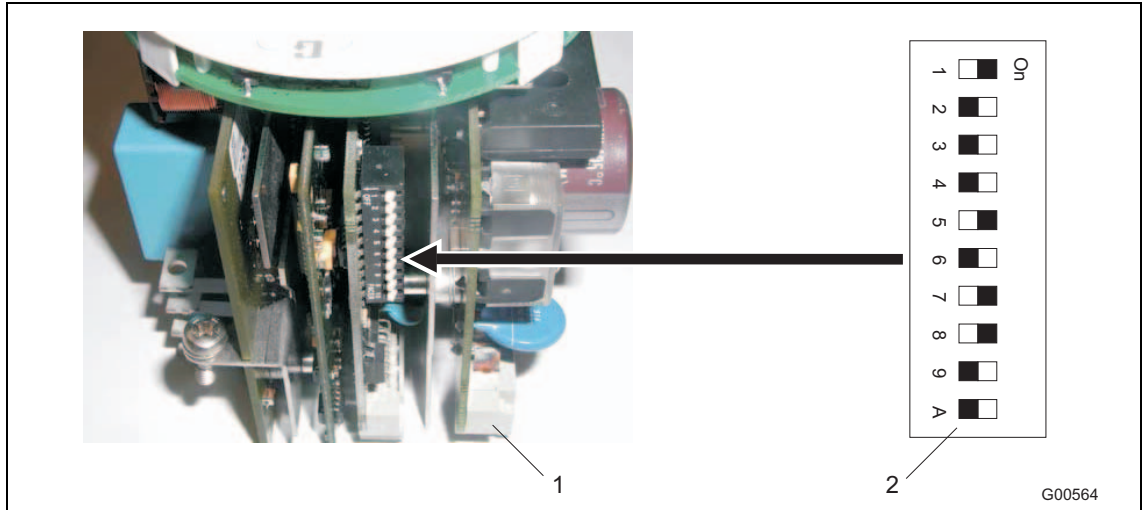

Fig. 39 Position of DIP switches

1 Transmitter plug-in module

2 DIP switch

Switches 1, 5, 7 = ON means:  $1+16+64 = 81 \rightarrow$  Bus address 81

Switch	1	2	3	4	5	6	7	8	9	A
Status	Unit address							Address mode	no function	no function
Off	0	0	0	0	0	0	0	Bus	no function	no function
On	1	2	4	8	16	32	64	Local	no function	no function

Switch assignments

Switch	Assignment
1 ... 7	PROFIBUS address
8	Defines the addressing mode: Off = Set address via bus (factory setting) On = Set address via DIP switches nos. 1 ... 7

**Device behaviour during turning on the power supply**

After switching on the auxiliary power, DIP switch 8 is polled:

Status	
ON	The address defined by DIP switches 1 ... 7 applies. The address can no longer be changed once the unit is in operation, since DIP switch 8 is polled only once when auxiliary power is turned on.
OFF (Default)	The transmitter uses the address stored in the FRAM of the gateway. At shipment the address is set to "126" or to the address specified by the customer. Once the unit is in operation, the address can be changed via the bus or directly on the unit using the keys on the display board. The unit must be connected to the bus.

**Device behavior after replacing transmitter plug-in module**

If the transmitter is located at the bus end and if the bus termination is activated via both hook switches, the bus termination is canceled when the transmitter plug-in module is removed. The bus is no longer terminated properly. To ensure proper operation, the bus termination must be connected at another location. If the transmitter plug-in module is reinstalled, the old bus termination can be used again.



**Important**

The selector is preconfigured with the ID no. 0x078C hex. The IDs 0x9700 or 0x9740 can also be used.

**5.2.1 Information on voltage/current consumption**

The behavior when switching on the unit corresponds to Draft DIN IEC / 65C / 155 / CDV of June 1996.

The average current draw by the unit on the fieldbus is 10 mA. The voltage on the bus line must be within 9 ... 32 V DC.



**Important**

The upper limit of the current is electronically limited. In the event of an error, the integrated FDE function (Fault Disconnection Electronic) integrated in the device ensures that the current consumption can rise to a maximum of 13 mA.

**5.2.2 System integration**

Use of PROFIBUS PA profile B, B3.0 ensures interoperability and interchangeability of units. Interoperability means that devices from different manufacturers can be physically connected to a bus and are communication-ready. In addition, third-party devices can be interchanged without having to reconfigure the process control system.

To support interchangeability, ABB provides three different GSD files (equipment master data) that can be integrated in the system.

Users decide at system integration whether to install the full range of functions or only part.



**Important**

Units are interchanged using the parameter ID number selector, which can only be modified on an acyclical basis.

The following table describes the available GSD files:

Number and type of function blocks	ID number	GSD file name
1 x AI	0x9700	PA139700.gsd
1 x AI; 1 x TOT	0x9740	PA139740.gsd
1 x AI; 2 x TOT; and all manufacturer-specific parameters	0x078C	ABB_078C.gsd

The manufacturer-specific GSD file ABB\_078C is available to download from the ABB homepage <http://www.abb.com/flow>.

The standard GSD files PA1397xx.gsd are available for download from the Profibus International homepage: <http://www.profibus.com>

### 5.3 Commissioning FOUNDATION Fieldbus units

For units with a FOUNDATION fieldbus, the settings of the DIP switch must be checked prior to commissioning.

When integrating the unit in a process control system, a DD file (device description) and a CFF file (common file format) are required. The DD file contains the device description. The CFF file is required for segment engineering. Engineering can be performed online or offline. The DD and CFF files are available to download from the ABB homepage <http://www.abb.com/flow>.

The DIP switches on the unit must be set correctly as follows:

DIP switch 1 must be OFF.

DIP switch 2 must also be OFF. Otherwise, the hardware write protection and the process control system prevent the unit from recording information.

The FOUNDATION fieldbus interface for the unit is compliant with the standards FF-890/891 and FF-902/90. The transmission signal of the transmitter is designed in accordance with IEC 61158-2.

The device is registered with the FOUNDATION fieldbus. The registration number is: IT 027200.

Registration for the FOUNDATION fieldbus is recorded under manufacturer ID 0x000320 and unit ID 0x0017.

**Seating of DIP switches**

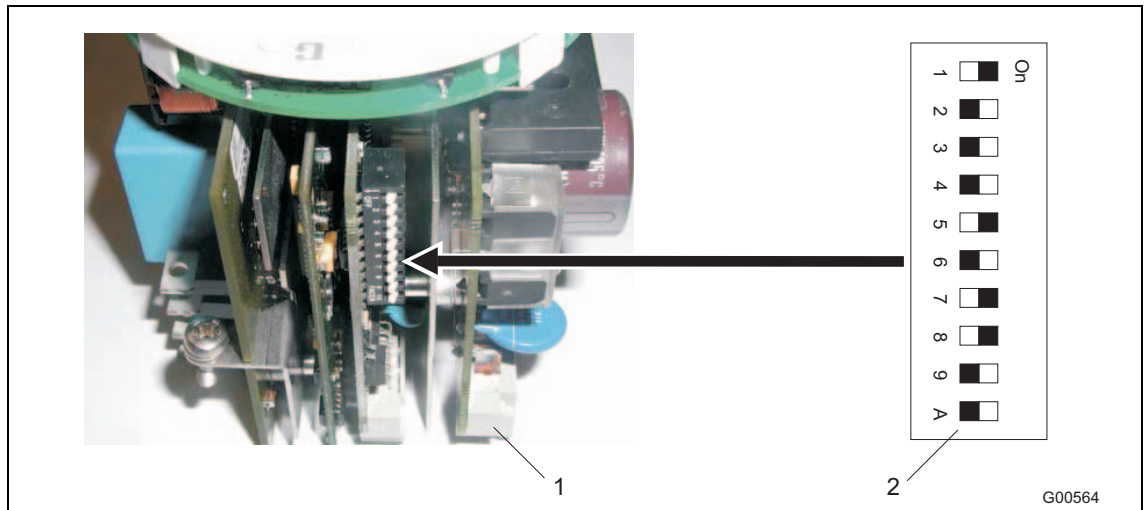

Fig. 40: Position of DIP switches

- 1 Transmitter plug-in module
- 2 DIP switch

**Assigning of DIP switches**

**DIP switch 1:**

Releases the simulation of the AI function blocks.

**DIP switch 2:**

Hardware write protection for write access via bus (locks all blocks).

DIP switch	1	2	3 ... 10
status	Simulation Mode	Write protect	no function
Off	Disabled	Disabled	no function
On	Enabled	Enabled	no function

**Bus address settings**

The bus address is automatically allocated at the FF via LAS (link active scheduler). For address detection, a unique number is used (DEVICE\_ID). This number is a combination of manufacturer ID, device ID and device serial number.

The behavior when switching on the unit corresponds to Draft DIN IEC / 65C / 155 / CDV of June 1996.

The average current draw of the unit is 10 mA. The voltage on the bus line must lie in the range of 9 ... 32 V DC.



**Important**

The upper limit of the current is electronically limited. In the event of an error, the integrated FDE function (Fault Disconnection Electronic) integrated in the device ensures that the current consumption can rise to a maximum of 13 mA.

## 6 Parameterization



### Important

For additional information about operation and menu navigation, refer to the operating instruction for the device.

### 6.1 Data entry

Use the keys (4) to enter data when housing is open. If closed, use the magnet stick (5) and the magnet sensors. The stick is held over the appropriate NS symbol.

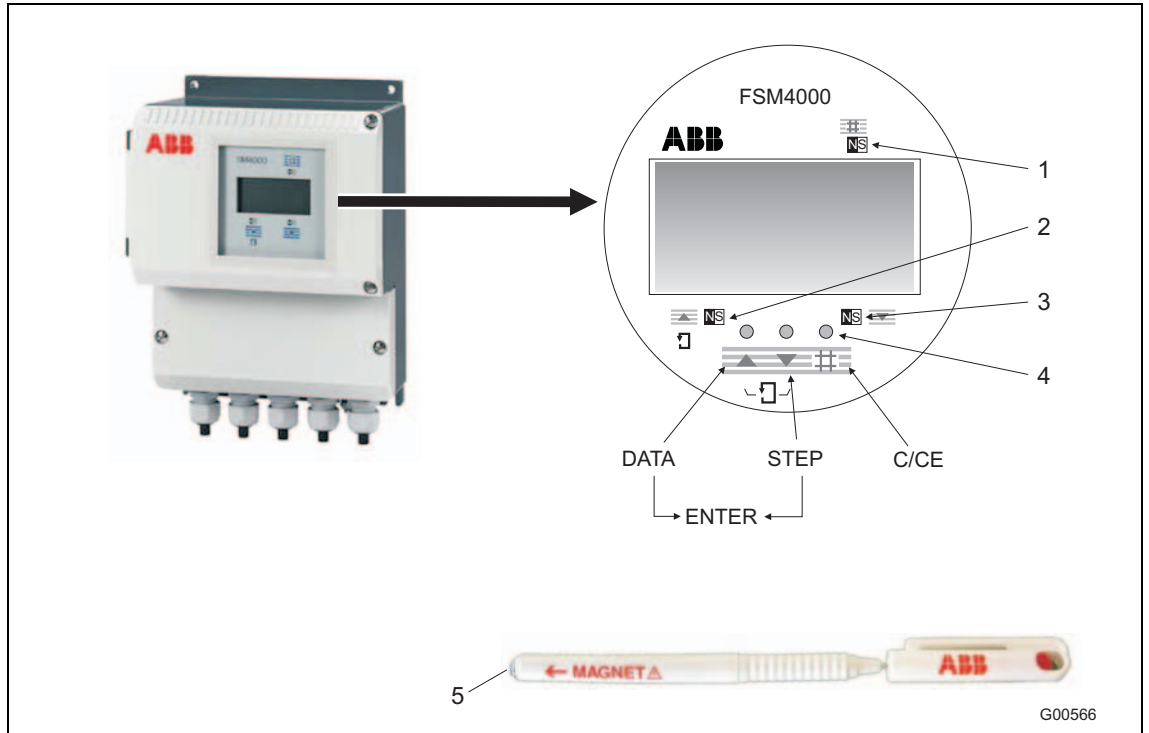





Fig. 41

- |                            |                   |
|----------------------------|-------------------|
| 1 Magnet sensor C/CE       | 4 Control buttons |
| 2 Magnet sensor DATA/ENTER | 5 Magnet          |
| 3 Magnet sensor STEP       |                   |

When entering data, the transmitter remains online, i.e., current and pulse outputs show the current operating mode. The functions of the individual keys are explained in the following:

-  C/CE Toggle between operating mode and menu.
-  STEP ↓ The STEP key is one of two arrow keys. Use STEP to scroll forward through the menu. All the desired parameters can be called up.
-  DATA ↑ The DATA key is one of two arrow keys. Use DATA to scroll backward through the menu. All the desired parameters can be called up.
-  ENTER The ENTER function requires that both arrow keys, STEP and DATA, be pressed simultaneously. ENTER has the following functions:
  - Access the parameter to be changed and set the new, selected or default parameter.

The ENTER function is effective for approx. 10 s only. If a new value is not entered within 10 s, the display reverts to the old value.

**ENTER function for magnet stick operation**

The ENTER function is initiated when the DATA/ENTER sensor is activated for more than 3 seconds. The display flashes to indicate that the function is active.

There are two different methods of entering data:

- Numeric entry
- Entry from specified table

**Important**

When entering data, the values are checked for plausibility and, if necessary, rejected with an appropriate message. The limit values (min/max) are displayed in the 3rd and 4th lines.

# Parameterization

## 6.2 Entering data in "short form"

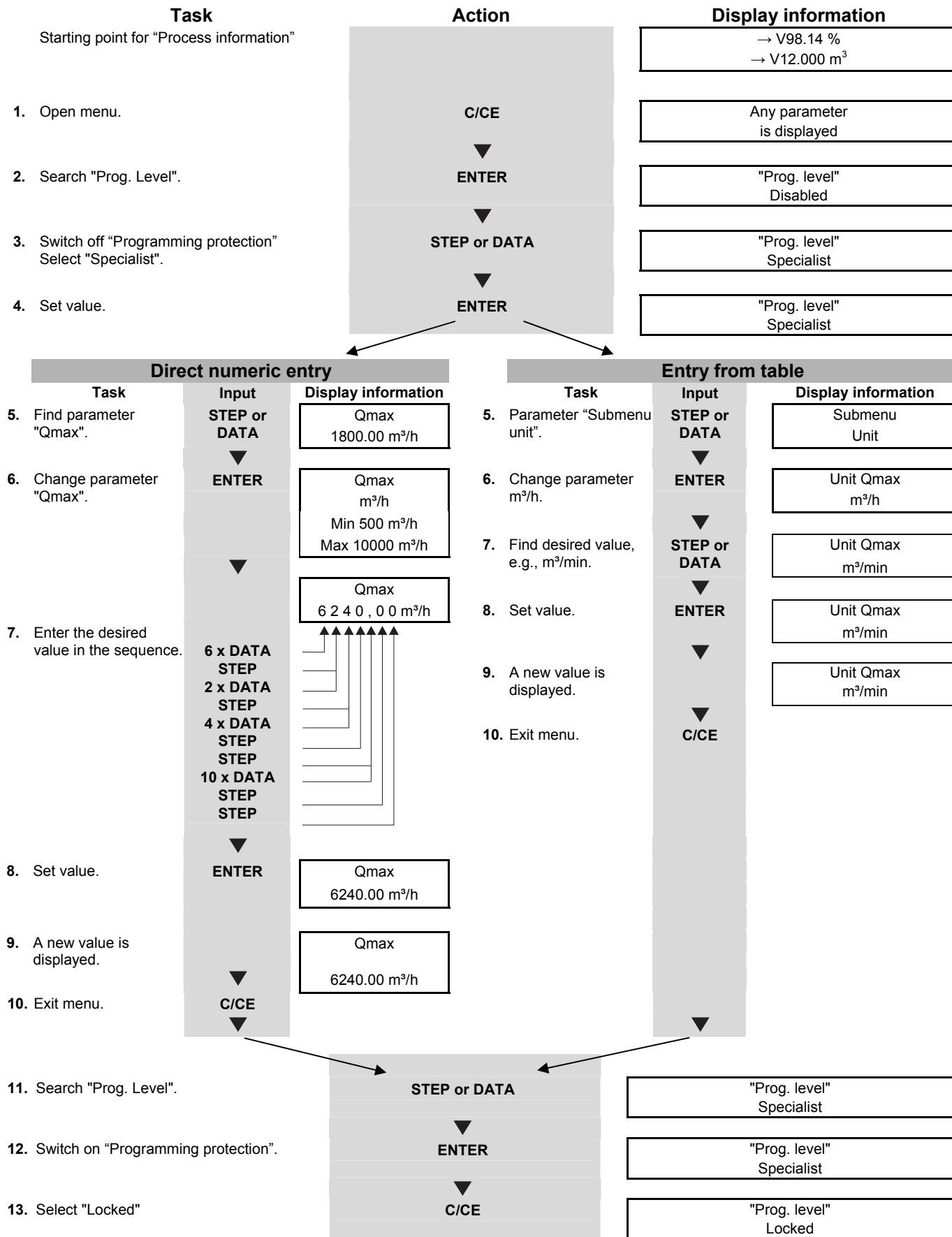

6.3 Easy Set-up: For uncomplicated configuration



The Easy Set-up function enables users to configure the transmitter for quick and convenient startup. For additional information about configuration options, see the operating instructions.

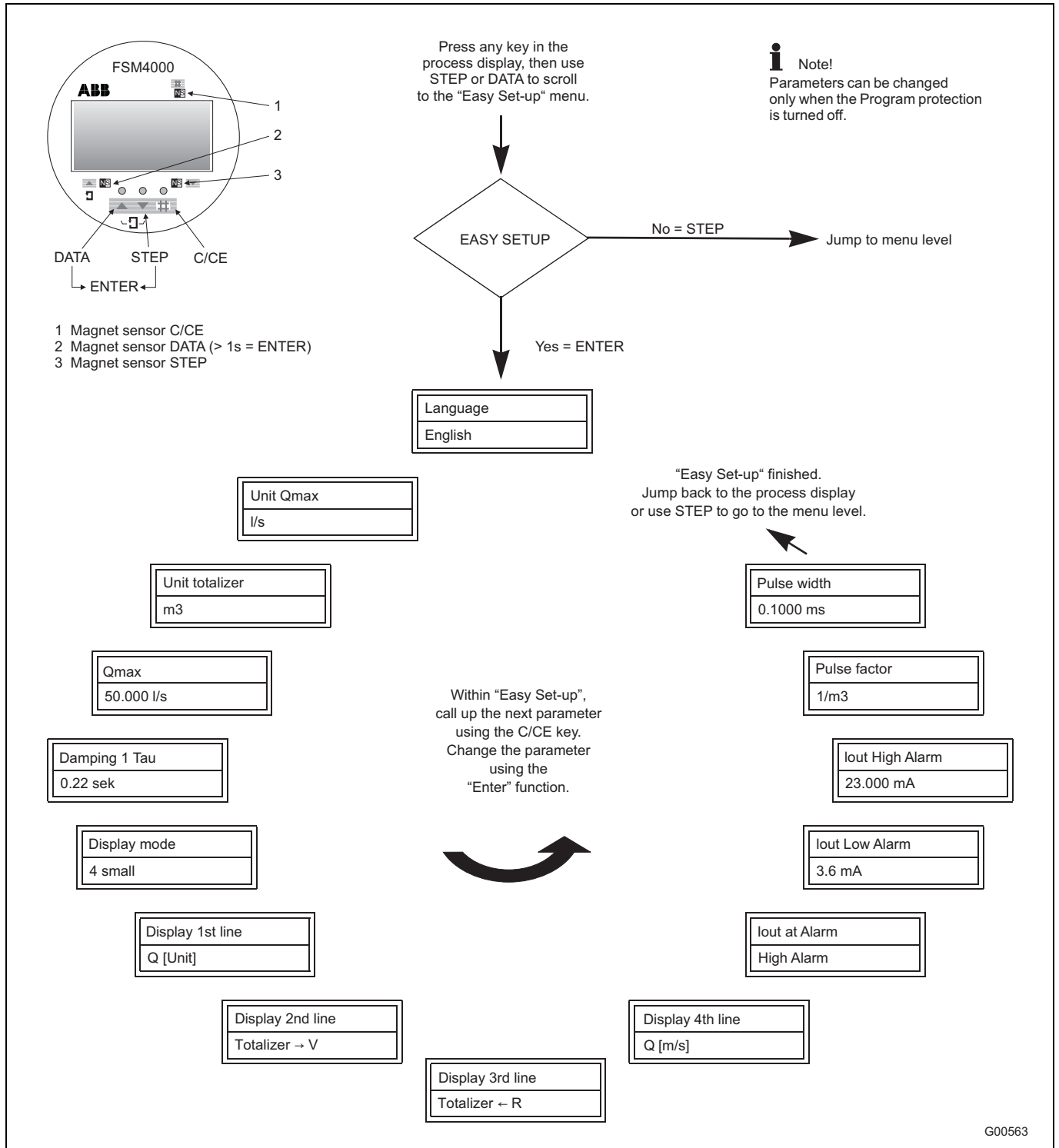



Fig. 42

## 7 Appendix

### 7.1 Other applicable documents

- Data sheet (D184S073Uxx)
- Operating instructions (D184B140Uxx)
- Interface description for devices with HART communication (D184B126U01/02)
- Interface description for devices with PROFIBUS PA communication (D184B093U29/30)
- Interface description for devices with PROFIBUS Fieldbus communication (D184B093U31/32)

### 7.2 Approvals and certifications

CE mark		<p>The version of the meter in your possession meets the requirements of the following European directives:</p> <ul style="list-style-type: none"> <li>- EMC directive 2004/108/EC</li> <li>- Low voltage directive 73/23/EWG</li> <li>- Pressure equipment directive (PED) 97/23/EC</li> </ul> <p>Pressure equipment does <u>not</u> receive a CE mark indicating PED compliance on the factory tag in the event of the following conditions prevailing:</p> <ul style="list-style-type: none"> <li>- The maximum permissible pressure (PS) is less than 0.5 bar</li> <li>- Due to low pressure risks (meter size <math>\leq</math> DN 25 / 1") no approval procedures are required.</li> </ul>
---------	---	--



#### Important

All documentation, declarations of conformity, and certificates are available in ABB's download area.

[www.abb.com/flow](http://www.abb.com/flow)



**EG-Konformitätserklärung  
EC-Declaration of Conformity**



Hiermit bestätigen wir die Übereinstimmung des aufgeführten Gerätes mit den Richtlinien des Rates der Europäischen Gemeinschaft, welche mit dem CE-Zeichen gekennzeichnet sind. Die Sicherheits- und Installationshinweise der Produktdokumentation sind zu beachten.

*Herewith we confirm that the listed instrument is in compliance with the council directives of the European Community and are marked with the CE marking. The safety and installation requirements of the product documentation must be observed.*

Hersteller: <i>manufacturer:</i>	ABB Automation Products GmbH, 37070 Göttingen - Germany
Modell: <i>model:</i>	D_2.., D_2_W, D_4_W, SE2.., SE2_W D_2.., D_2_W, D_4_W, SE2.., SE2_W
Richtlinie: <i>directive:</i>	Druckgeräterichtlinie 97/23/EG <i>pressure equipment directive 97/23/EC</i>
Einstufung: <i>classification:</i>	Ausrüstungsteile von Rohrleitungen <i>pipng accessories</i>
Normengrundlage: <i>technical standard:</i>	AD 2000 Merkblätter
Konformitätsbewertungsverfahren: <i>conformity assessment procedure:</i>	B1 (EG-Entwurfsprüfung) + D (Qualitätssicherung Produktion) <i>B1 (EC design-examination) + D (production quality assurance)</i>
EG-Entwurfsprüfbescheinigung: <i>EC design-examination certificate:</i>	Nr. 07 202 0124 Z 052/2/0006
benannte Stelle: <i>notified body:</i>	TÜV Nord e.V. Rudolf-Diesel-Str. 5 37075 Göttingen - Germany
Kennnummer: <i>identification no.</i>	0045

Göttingen, den 21.05.2002

  
ppa .....  
(K.Wiskow, Personalleiter APR Göttingen)



## EG-Konformitätserklärung EC-Declaration of Conformity



Hiermit bestätigen wir die Übereinstimmung des aufgeführten Gerätes mit den Richtlinien des Rates der Europäischen Gemeinschaft, welche mit dem CE-Zeichen gekennzeichnet sind. Die Sicherheits- und Installationshinweise der Produktdokumentation sind zu beachten.

*Herewith we confirm that the listed instrument is in compliance with the council directives of the European Community and are marked with the CE marking. The safety and installation requirements of the product documentation must be observed.*

Hersteller: <i>manufacturer:</i>	ABB Automation Products GmbH, 37070 Göttingen - Germany
Modell: <i>model:</i>	SE2_F, D_2_F, SE4_F, D_4_F SE2_F, D_2_F, SE4_F, D_4_F
Richtlinie: <i>directive:</i>	Druckgeräterichtlinie 97/23/EG pressure equipment directive 97/23/EC
Einstufung: <i>classification:</i>	Ausrüstungsteile von Rohrleitungen piping accessories
Normengrundlage: <i>technical standard:</i>	AD 2000 Merkblätter
Konformitätsbewertungsverfahren: <i>conformity assessment procedure:</i>	B1 (EG-Entwurfsprüfung) + D (Qualitätssicherung Produktion) B1 (EC design-examination) + D (production quality assurance)
EG-Entwurfsprüfbescheinigungen: <i>EC design-examination certificates:</i>	Nr. 07 202 0124 Z 0052/2/0002 Nr. 07 202 0124 Z 0052/2/0002a
benannte Stelle: <i>notified body:</i>	TÜV Nord e.V. Rudolf-Diesel-Str. 5 37075 Göttingen - Germany
Kennnummer: <i>identification no.</i>	0045

Göttingen, den 21.10.2002

ppa .....  
(B.Kammann, Standortleiter APR Göttingen)

BZ-25-0002 Rev.02



**EG-Konformitätserklärung**  
**EC Declaration of Conformity**

Hiermit bestätigen wir die Übereinstimmung der aufgeführten Geräte mit den Richtlinien des Rates der Europäischen Gemeinschaft, welche mit dem CE-Zeichen gekennzeichnet sind. Die Sicherheits- und Installationshinweise der Produktdokumentation sind zu beachten.

*We herewith confirm that the listed devices are in compliance with the council directives of the European Community and are marked with the CE marking. The safety and installation requirements of the product documentation must be observed.*

Hersteller:  
*Manufacturer:* ABB Automation Products GmbH,  
 Dransfelder Straße 2, 37079 Göttingen - Germany

Gerät:  
*Device:* Magnetisch-induktiver Durchflussmesser  
 Electromagnetic Flowmeter

Modelle:  
*Models:* FSM4000-S4 / -SE21 / -SE41 / -DS21  
 FSM4000-S4 / -SE21 / -SE41 / .DS21

EG-Richtlinie:  
*EC directive:* 2004/108/EG \* (EMV)  
 2004/108/EC \* (EMC)

Europäische Norm:  
*European Standard:* EN 61326-1, 10/2006 \* EN 61326-2-3, 05/2007  
 EN 61326-1, 10/2006 \* EN 61326-2-3, 05/2007

EG-Richtlinie:  
*EC directive:* 2006/95/EG \* (Niederspannungsrichtlinie)  
 2006/95/EC \* (Low voltage directive)

Europäische Norm:  
*European Standard:* EN 61010-1, 08/2002 \*  
 EN 61010-1, 08/2002 \*

\* einschließlich Nachträge / *including alterations*

Göttingen, 07. Juli 2009

i.V. Dr. Günther Kuhlmann  
 (R&D Manager)

i.A. Dirk Steckel  
 (R&D Electrical Safety)

**ABB Automation Products GmbH**

BZ-13-5111, Rev.02, 13058

Postanschrift:  
 Dransfelder Str. 2  
 D-37079 Göttingen

Besuchsanschrift:  
 Dransfelder Str. 2  
 D-37079 Göttingen  
 Telefon +49 551 905 0  
 Telefax+49 551 905 777  
 Internet: <http://www.abb.com/de>

Sitz der Gesellschaft:  
 Ladenburg  
 Registergericht:  
 Amtsgericht Mannheim  
 Handelsregister:  
 HRB 700229  
 USt-IdNr.: DE 115 300 097

Vorsitz des Aufsichtsrates:  
 Hans-Georg Krabbe  
 Geschäftsführung:  
 Christian Wendler

Bankverbindung:  
 Commerzbank AG Frankfurt  
 Konto: 589 635 200  
 BLZ: 500 400 00

---

ABB has Sales & Customer Support expertise in over 100 countries worldwide.

[www.abb.com/flow](http://www.abb.com/flow)

The Company's policy is one of continuous product improvement and the right is reserved to modify the information contained herein without notice.

Printed in the Fed. Rep. of Germany (07.2010)

© ABB 2010



**ABB Limited**

Oldends Lane, Stonehouse  
Gloucestershire, GL10 3TA  
UK

Tel: +44 (0)1453 826661  
Fax: +44 (0)1453 829671

**ABB Inc.**

125 E. County Line  
Road  
Warminster, PA 18974  
USA

Tel: +1 215 674 6000  
Fax: +1 215 674 7183

**ABB Automation Products GmbH**

Dransfelder Str. 2  
37079 Goettingen  
Germany

Tel: +49 551 905-534  
Fax: +49 551 905-555

D184B141U02 Rev. A