

Power Electronic Unit EBN853, EBN861 (Contract)

For Control of Contract Actuators
in the explosion protection area

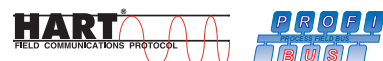

Power Electronic Unit

EBN853, EBN861 (Contract)

Operating Instructions

42/68-830-EN

02.2008

Rev. B

Manufacturer:

ABB Automation Products GmbH

Schillerstraße 72

32425 Minden

Germany

Tel.: +49 551 905-534

Fax: +49 551 905-555

CCC-support.deapr@de.abb.com

© Copyright 2008 by ABB Automation Products GmbH
Subject to change without notice

This document is protected by copyright. It assists the user with the safe and efficient operation of the device. The contents may not be copied or reproduced in whole or in excerpts without prior approval of the copyright holder.

1	Safety	5
1.1	General Safety Information	5
1.2	Proper use	5
1.3	Technical limits	5
1.4	Warranty provision	6
1.5	Labels and symbols.....	6
1.5.1	Symbols and warnings	6
1.5.2	Name plate	7
1.5.3	Name plate for the electronic unit	7
1.5.4	Name plate for the lower section of the electronic unit	7
1.5.5	Name plate from electronic unit cover	7
1.5.6	Name plate for hardware description	8
1.6	Operator liability	8
1.7	Personnel qualification	8
1.8	Returning devices.....	9
1.9	Disposal.....	9
1.9.1	Information on WEEE directive 2002/96/EC (Waste Electrical and Electronic Equipment)	9
1.10	Transport safety information	9
1.11	Storage conditions.....	10
1.12	Installation safety information.....	10
1.13	Electrical installation safety information	10
1.14	Operating safety information	11
2	Explosion-protection safety precautions	11
2.1	Operation via frequency transformer.....	11
2.2	Using the engineering software Save & Restore and ECOM688	11
3	Design and function	12
3.1	Modules	13
3.1.1	EBN853	13
3.1.2	EBN861	14
3.2	Factory default.....	15
4	Installation	15
4.1.1	EBN853	15
4.1.2	EBN861	16
5	Electrical connection	17
5.1	Cable shield.....	18
5.1.1	Signal part	18
5.1.2	Motor	18
5.2	Terminal connection diagrams	19
5.2.1	Power Electronic Unit EBN853 (Contrac)	19

Contents

5.2.2	Power Electronic Unit EBN861 (Contrac)	21
5.2.3	External fuse for EBN861.....	23
5.3	Configuration of digital input/output signals	23
5.3.1	Standard.....	23
5.3.2	Downstream from step controller	24
6	Local operation.....	24
6.1	General information on operation.....	24
6.2	Operating elements of the service field (ISF).....	25
7	Commissioning and service field (ISF)	26
7.1	Typical commissioning with the service field (ISF)	26
7.1.1	Opening the cover flap of the ISF	26
7.1.2	Status	26
7.1.3	Operating mode "Device setup"	26
7.1.4	Setup via user interface	26
7.1.5	Defining the initial position (0% or 100%)	27
7.1.6	Defining the second position (0% or 100%).....	27
7.1.7	Saving your settings.....	27
7.1.8	Correcting settings	28
8	Alarms / Errors.....	29
8.1	Definition	29
8.1.1	Alarms	29
8.1.2	Error	29
8.2	Alarm diagram	29
8.3	Error diagram	30
9	Trouble shooting	31
10	Technical data.....	32
10.1	Power Electronic Unit EBN853 (Contrac)	32
10.2	Power Electronic Unit EBN861 (Contrac)	33
11	Appendix	34
11.1	Permits and certifications	34
12	Index	36

1 Safety

Read these operating instructions carefully prior to installing and commissioning the device.

These instructions are intended as an overview and do not contain detailed information on all designs for this product or every possible aspect of installation, operation and maintenance.

For additional information or in case specific problems occur that are not discussed adequately in these instructions, contact the manufacturer. In addition, we declare that the contents of these instructions are not part of any prior or existing agreements, commitments or legal relationships or are intended to amend these.

All obligations of ABB Automation Products GmbH are created by the relevant sales agreement, which contains the complete and solely binding warranty regulations. These contractual warranty provisions are neither extended nor limited by compliance with this manual.

1.1 General Safety Information

The "Safety" chapter provides an overview of the safety aspects to be observed for the operation of the device.

The device is built based on state-of-the-art technology and is operationally safe. It was tested and left the factory in a proper state. The requirements in the manual as well as the documentation and certificates must be observed and followed in order to maintain this state for the period of operation.

The general safety requirements must be complied with completely during operation of the device. In addition to the general information, the individual chapters of the manual contain descriptions about processes or procedural instructions with specific safety information.

Only the observance of all safety information enables the optimal protection of personnel as well as the environment from hazards and the safe and trouble-free operation of the device.

1.2 Proper use

The power electronic units for type EBN853 and EBN861 with the interconnection shown in these operating instructions are used to control electrical actuators in the series RHD... or RSD.... Do not use these actuators for any other purpose. Otherwise, a hazard of personal injury or of damage to or impairment of the operational reliability of the device may arise.

Repairs, alterations and enhancements or the installation of replacement parts is only permissible as far as described in the manual. Further actions must be verified with ABB Automation Products GmbH. Excluded from this are repairs performed by ABB-authorized specialist shops.

1.3 Technical limits

The device is designed for use exclusively within the stated values on the name plate and in the technical specifications (see "Technical Specifications" chapter and data sheet). These must be complied with accordingly, e.g.:

- The maximum operating temperature may not be exceeded.
- The permitted operating temperature may not be exceeded.
- The housing protection system must be observed.

1.4 Warranty provision

A use contrary to the device's stipulated use, disregarding of this manual, the use of under-qualified personnel as well as unauthorized alterations excludes the manufacturer of liability from any resulting damages. The manufacturer's warranty expires.

1.5 Labels and symbols

1.5.1 Symbols and warnings



Danger – <Serious damage to health / risk to life>

One of these symbols in conjunction with the “Danger” warning indicates an imminent danger. If it is not avoided, death or serious injury will result.



Warning – <Bodily injury>

The symbol in conjunction with the “Warning” message indicates a possibly dangerous situation. If it is not avoided, death or serious injury could result.



Caution – <Slight injuries>

The symbol in conjunction with the “Caution” message indicates a possibly dangerous situation. If it is not avoided, slight or minor injury can result. May also be used for property damage warnings.



Notice – <Property damage>!

The symbol indicates a possibly damaging situation. If it is not avoided, the product or something in its area can be damaged.



Important

The symbol indicates operator tips or especially useful information. This is not a message for a dangerous or damaging situation.

1.5.2 Name plate

1.5.3 Name plate for the electronic unit

The name plates for the power electronic unit are located on the lower section (mains connection) as well as on the cover (electronic unit and software). Since the modules are stand-alone units, order numbers may vary.

1.5.4 Name plate for the lower section of the electronic unit

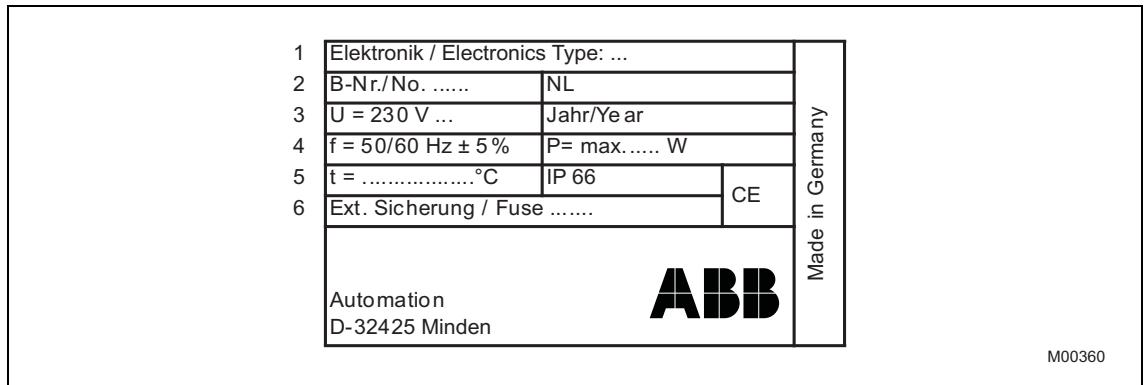

Fig. 1

- | | |
|---|--|
| 1 Electronic unit type | 4 Permissible line frequency / max. power |
| 2 Unit no. / no. of the non-list version | 5 Permissible ambient temperature / Protection class |
| 3 Permissible voltage range / Year of manufacture | 6 Specifications for external fuse protection |

1.5.5 Name plate from electronic unit cover

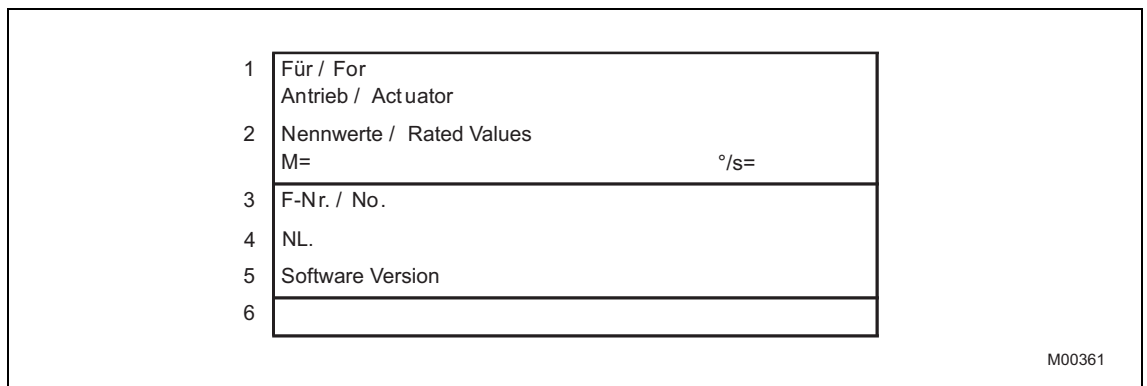

Fig. 2

- | | |
|--------------------------------------|------------------------------------|
| 1 Associated actuator | 4 Number of the non-list version |
| 2 Ratings for force/torque and speed | 5 Installed software version |
| 3 Serial number of electronic unit | 6 Free for customer-specific entry |

1.5.6 Name plate for hardware description

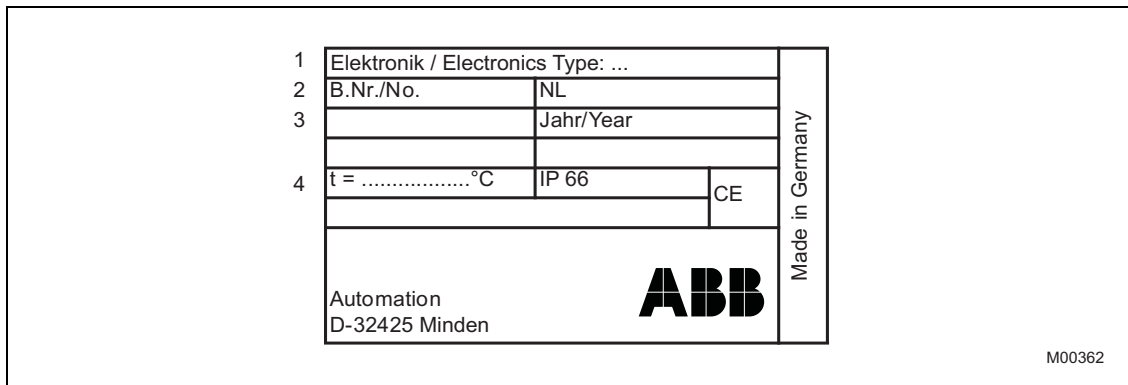

Fig. 3

- | | |
|--|--|
| 1 Electronic unit type | 3 Year |
| 2 Unit no. / no. of the non-list version | 4 Permissible ambient temperature / Protection class |

1.6 Operator liability

The operators must strictly observe the applicable national regulations in their countries with regards to installation, function tests, repairs, and maintenance of electrical devices.

1.7 Personnel qualification

The installation, commissioning and maintenance of the device may only be carried out through trained specialist personell authorized by the plant operator. The specialist personnel must have read and understood the manual and comply with its instructions.

1.8 Returning devices

Use the original packaging or a suitably secure packaging for returning the device for repair or for recalibration. Include the properly filled out return form (see attachment) with the device.

According to EC guidelines for hazardous materials, the owner of hazardous waste is responsible for its disposal or must observe the following regulations for its shipping:

All delivered devices to ABB Automation Products GmbH must be free from any hazardous materials (acids, alkali, solvents, etc.).

1.9 Disposal

ABB Automation Products GmbH actively promotes environmental consciousness and has an operational management system in accordance with DIN EN ISO 9001:2000, EN ISO 14001:2004 and OHSAS 18001. Our products and solutions should have minimum impact on the environment and persons during manufacture, storage, transport, use and disposal.

This includes the environmentally friendly use of natural resources. Through its publications ABB conducts an open dialog with the public.

This product/solution is manufactured from materials that can be reused by specialized recycling companies.

1.9.1 Information on WEEE directive 2002/96/EC (Waste Electrical and Electronic Equipment)

This product/solution is not subject to the WEEE directive 2002/96/EC and relevant national laws (e.g., ElektroG in Germany).

Dispose of the product/solution directly in a specialized recycling facility and do not use the municipal garbage. Only privately used products may be disposed of in the municipal garbage according to the WEEE directive 2002/96/EC. Proper disposal prevents negative effects on people and the environment, and supports the reuse of valuable raw materials.

If it is not possible to dispose of old equipment properly, ABB Service can accept and dispose of returns for a fee.

1.10 Transport safety information

Check the devices for possible damage that may have occurred from improper transport. Damages in transit must be recorded on the transport documents. All claims for damages must be claimed without delay against the shipper and before the installation.

1.11 Storage conditions

The units may be stored under moist and aggressive condition for a short time. The equipment is protected against external corrosive influences. However, direct exposure to rain, snow, etc., must be avoided.

For electronics modules delivered for use in anti-condensation areas, the electrical connection chamber is protected by a desiccant.

The desiccant guarantees sufficient protection for approximately 150 days. It can be regenerated at a temperature of 90 °C (114 °F) within 4 h.



Important

Remove the desiccant prior to commissioning the actuator or the electronic unit.

If you intend to store or transport the device for a longer time, we recommend that you wrap it in plastic foil and add desiccant. Regularly check whether the desiccant is still active.

1.12 Installation safety information

- Only qualified specialists who have been trained for these tasks are authorized to mount and adjust the control actuator, and to make the electrical connection.
- When working on the actuator itself or the electronics always observe the locally valid accident prevention regulations and the regulations concerning the construction of technical installations.
- Switch off the supply voltage and protect against unintentional startup.

1.13 Electrical installation safety information

The electrical connection may only be performed by authorized specialist personnel according to the electrical plans.

Comply with electrical connection information in the manual. Otherwise, the electrical protection class can be affected.

The secure separation of contact-dangerous electrical circuits is only guaranteed when the connected devices fulfill the requirements of the DIN EN 61140 (VDE 0140 Part 1) (basic requirements for secure separation).

For secure separation, run the supply lines separated from contact-dangerous electrical circuits or additionally insulate them.

1.14 Operating safety information

Before switching on, ensure that the specified environmental conditions in the “Technical Specifications” chapter or data sheet are complied with and that the power supply voltage corresponds with the voltage of the electronic unit.

When there is a chance that safe operation is no longer possible, put the device out of operation and secure against unintended operation.

When mounting the power electronic unit in areas that may be accessed by unauthorized persons, take the required protective measures.

2 Explosion-protection safety precautions

2.1 Operation via frequency transformer

- The frequency converter (electronic unit) may not be installed or used within the hazardous area.
- Check whether the electronic unit is loaded with the parameters of the actuator it is connected to.
- Check the electronic unit for proper connection to the correct actuator.
- Setpoint monitoring is activated as default setting when the electronic unit leaves the manufacturer. Do not de-activate this setting.
- Rapid traverse mode is not allowed on Ex actuators, and the feature cannot be activated from the user interface.
- The Contrac power electronic unit must be upstream from the motor temperature monitoring unit SD241B or similar, certified tripping unit.

2.2 Using the engineering software Save & Restore and ECOM688

Reinstalling the electronic unit software or individual data sections with the engineering software Save & Restore or ECOM688 may only be performed in compliance with the relevant basic conditions. It must be ensured, specifically, that the data record imported belongs to the actuator type. After importing a data record, always check that all parameters for the application such as speed and torque/force are configured accordingly.

Downdating the actuator operating system (UAPM software version) is not permitted.

Refer to the valid operating instructions for the engineering software ECOM688. The operating instructions are available for download on the internet.

3 Design and function

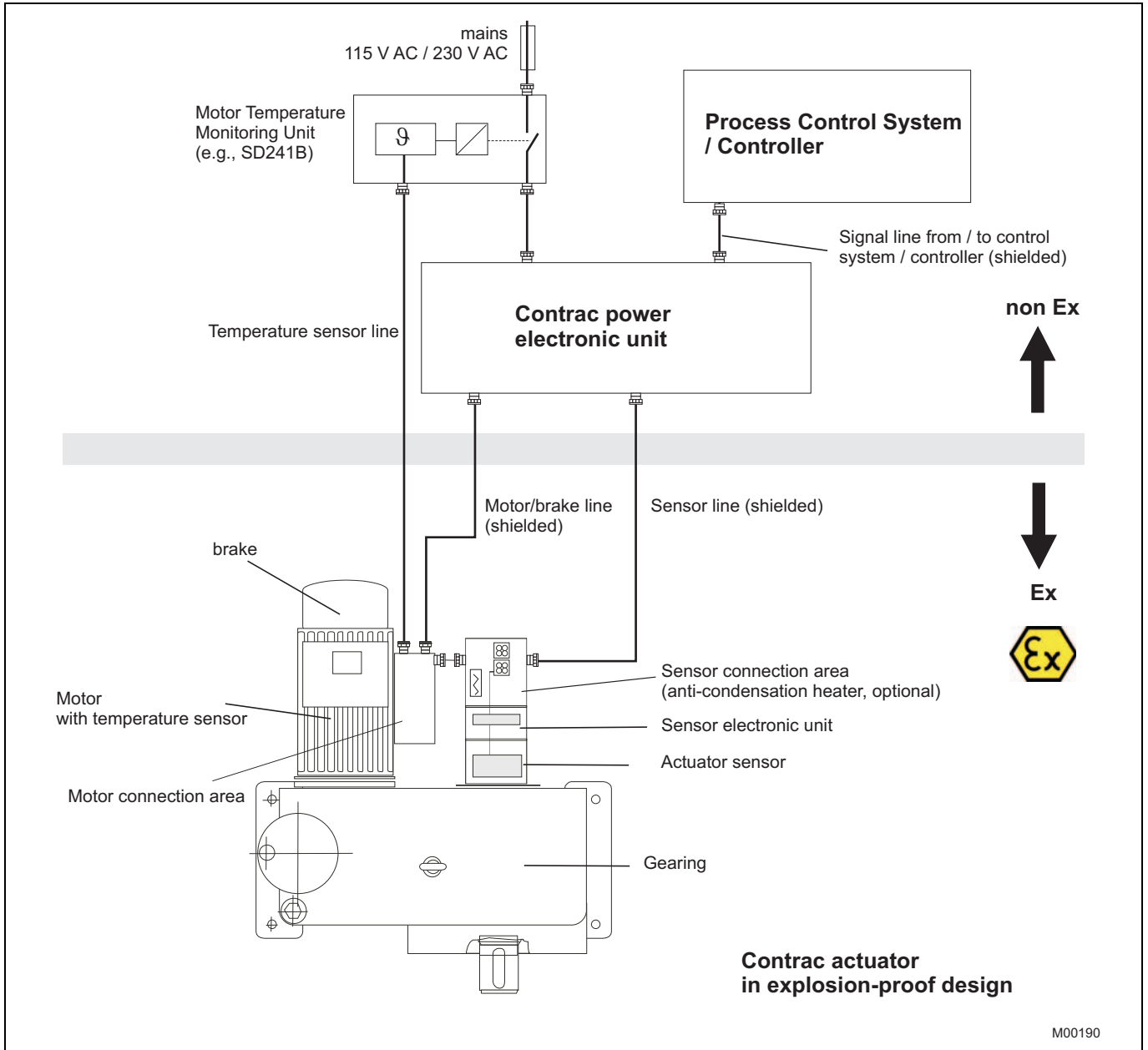

Fig. 4: Ex design

3.1 Modules

The power electronic units EBN853, EBN861 (Contrac) consist of 2 housing halves, one holding the connection components (EBN853) and the other holding the electronics and the commissioning and service field (ISF) for "local operation" and actuator setup.

3.1.1 EBN853

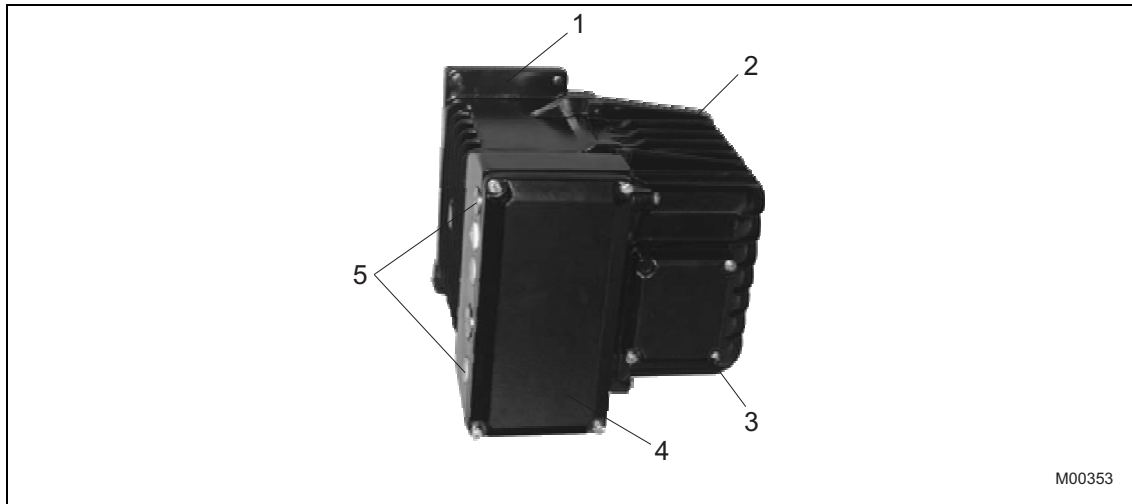

Fig. 5

- | | |
|---------------------|-----------------------------|
| 1 Terminal box | 4 Cover for connection area |
| 2 Electronics cover | 5 Holes for cable glands |
| 3 Cover for ISF | |

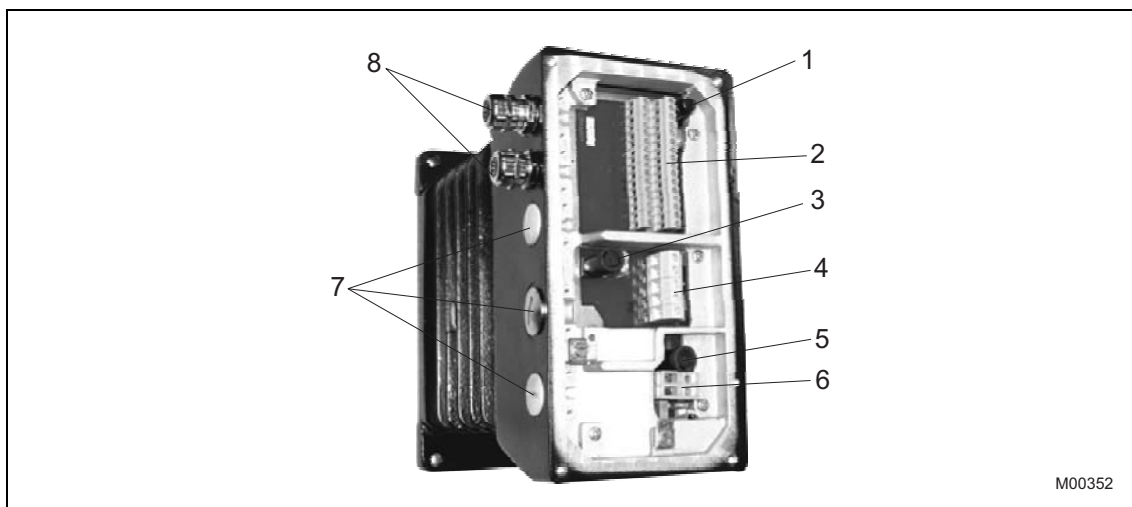

Fig. 6: Connection area

- | | |
|---|--------------------------|
| 1 Fuse protection against active feed at 20 mA setpoint input | 5 Mains fuse |
| 2 Signal terminals | 6 Mains supply terminals |
| 3 Fuse for heating resistor | 7 Tap holes |
| 4 Motor terminals | 8 Cable gland |

Standard delivery scope: Tap holes with covers.
Adapters for PG or NPT cable glands are optionally available.

3.1.2 EBN861

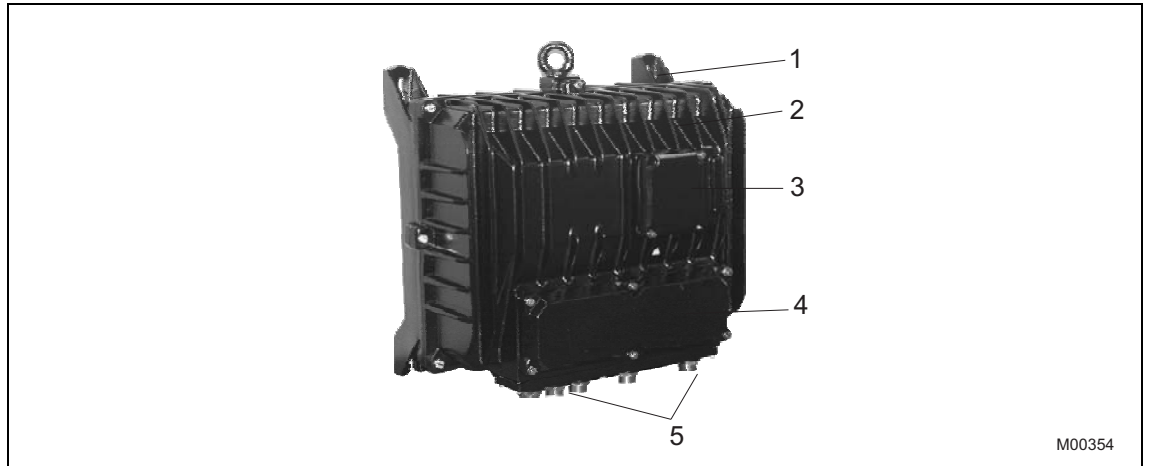

Fig. 7: EBN861

- | | |
|----------------------------------|-----------------------------|
| 1 Electronic unit, lower section | 4 Cover for connection area |
| 2 Electronics cover | 5 Holes for cable glands |
| 3 Cover for ISF | |

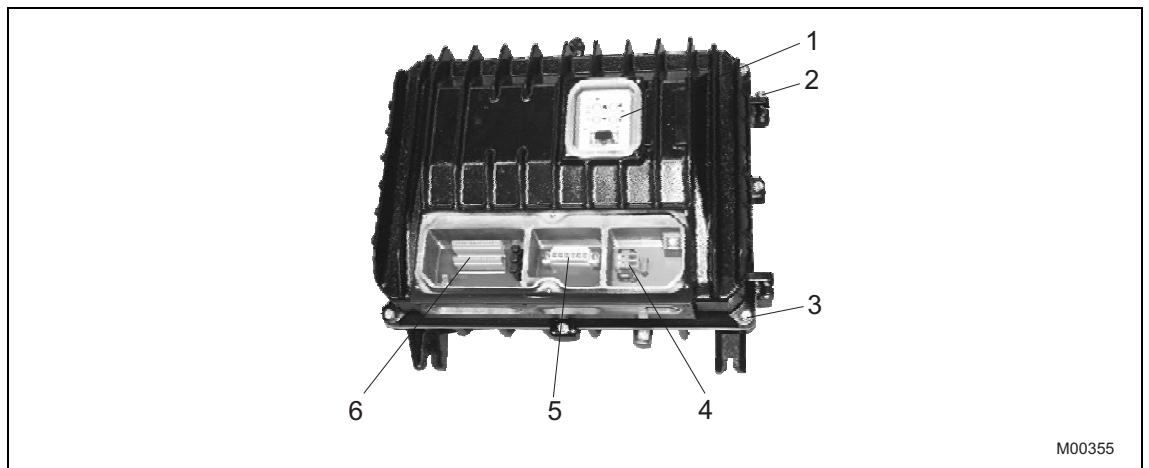

Fig. 8: EBN861 connection area

- | | |
|---|--------------------------|
| 1 Commissioning and service field (ISF) | 4 Mains supply terminals |
| 2 Hinge screws | 5 Motor terminals |
| 3 Cover screws | 6 Signal terminals |

3.2 Factory default

Unless otherwise specified by the user, the power electronic units are delivered with the following standard configuration:

Behavior in 0/100 % end position:	Observe rated torque/force
Setpoint function:	Linear; setpoint = position value
Setpoint input:	4 ... 20 mA ¹⁾
Function selection:	Positioner, parameter: setpoint
Positioning time-out:	activated
Actual output value:	4 ... 20 mA
Digital input: ¹⁾	DI 1 M/A switching; DI 2 / DI 3 manual operation +/-
Digital output: ¹⁾	DO 1 ready for operation, DO 2/3 end position signal
Operating range:	not setup

The individual actuator configuration may vary from the standard setup above. This information can be displayed via the user interface.

1) Not for communication via field bus

4 Installation



Important

Prior to installation or service activities, the electronic unit and actuator must be disconnected from the power supply and secured to prevent unintentional startup.

- It must also be possible to disconnect the electronic unit and actuator onsite.
- All signal and motor cables between the actuator and electronic unit must be shielded.
- The shielding must be placed on both housings when connecting the electronic unit and the actuator.

4.1.1 EBN853

1. Module mounted on vertical support with screws of property class 8.8 (tensile strength 800 N/mm² (116032 pounds/square inch), 640 N/mm² (92826 pounds/square inch).
2. Provide adequate room for installation and make sure the actuator is accessible from all sides.
3. Cable glands point to the left.
4. Remove the cover for the connection chamber (**Fig. 5**, pos. 4).
5. Insert the cable through the cable gland and connect according to the connection diagram.
6. Check that the cable connections are properly seated, tighten cable gland, and close the cover of the connection box.

4.1.2 EBN861

**Important**

The total weight of the electronic unit EBN861 is 40 kg (88 lbs). For this reason, the electronic unit is equipped with a load-bearing eyelet. If, for technical reasons, the load-bearing eyelet cannot be used, install the two housing halves separately.

Separating the housing halves

1. Place the electronic unit on a horizontal surface.
2. Unscrew and remove the cover screws (**Fig. 7**, pos. 3).
3. Open the electronic unit.
4. Disconnect the internal plug connection between the housing halves.
5. Close the housing halves.
6. Unscrew and remove the hinge screw (**Fig. 7**, pos. 2).
7. Fold the front section forward while lifting upward and off the hinge pins. Move the cover of the electronic unit carefully.

Installing the housing halves

1. Set the housing halves on the hinge pins and replace the screw in the upper pin. Move the cover of the electronic unit carefully.
2. Restore the internal plug connection.
3. Close the housing, and insert and connect the cover screws (**Fig. 7**, pos. 3).

Mounting

1. Module mounted on vertical support with screws of property class 8.8 (tensile strength 800 N/mm² (116032 pounds/square inch), 640 N/mm² (92826 pounds/square inch).
2. Provide adequate room for installation and make sure the actuator is accessible from all sides.
3. Cable glands point downward.
4. Remove the cover for the connection chamber (**Fig. 7**, pos. 4).
5. Insert the cable through the cable gland and connect according to the connection diagram.
6. Check that the cable connections are properly seated, tighten cable gland, and close the cover of the connection box.

5 Electrical connection

Each actuator requires a Contrac electronic unit which is loaded with the type specific-software. Carefully consider the instructions for the electronic unit and compare the data labels of the actuator and the electronic unit in order to ensure a proper hard- and software assignment.

The cable between the actuator and the electronic unit is connected to terminals.



Instructions regarding use in Ex applications

The electrical connection between the Contrac electronic unit and the Contrac actuator can be established using the cable set (order code 695). The cable harness is not part of the Ex prototype test certificate and must therefore be tested for safety-relevant functionality within the complete installation by the installer or operator.

Consider the following issues:

- Consider the local regulation concerning the setup of electrical devices within hazardous areas. This applies particularly to EN 60079-14 for the setup of the screen and the potential compensation between the actuator, the electronic unit and the motor protection unit (see 1) in chapter **Cable shield**, page 18 and chapter **Terminal connection diagrams**, page 19 ff.
- For the connection of the motor and the position transmitter only use ATEX certified EEx e cable glands with IP 66 acc. to EN 50019.
- Use a cable socket or a solid wire, bended to a "U", to connect the motor cable.
- Ensure a proper strain relief for all cable connections.
- Protect all cables in the connections chambers against contact with metal components. Ensure a gap of at least 6 mm between all conductive components.
- Remove the desiccant in motor and position sensor.
- Do not change the factory-set position of the motor terminal chamber.
- Seal all not used cable entries with ATEX certified IP 66 plugs.
- Use a certified cut-off unit for the thermal motor monitoring. Permitted units are, e.g.:
 - ABB motor temperature monitoring unit SD 241 B
 - 3 RN 1011-1 CK 00 , Ex II (2) GD , PTB 01 ATEX 3218, Siemens

5.1 Cable shield

5.1.1 Signal part

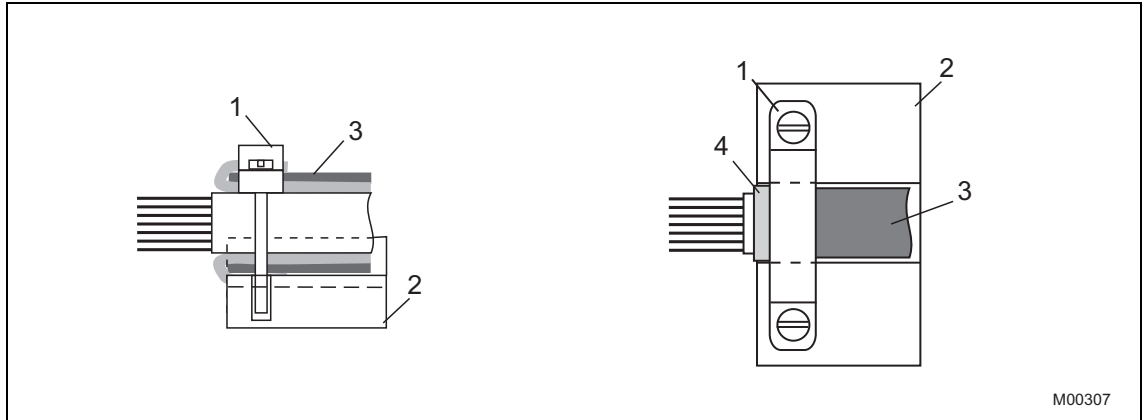

Fig. 9: Fitting the shield

1. Remove approx. 2 cm of cable sheathing (3) from the end of the cable.
2. Separate the shield and peel it back to its inner sheathing (4).
3. Push the cable through the cable gland and fasten with clamp (1).
4. Make sure that the shielding is touching the clamp and the electronic unit housing (2).

5.1.2 Motor

The cable shield must be connected to the motor in a proper manner.

5.2 Terminal connection diagrams

5.2.1 Power Electronic Unit EBN853 (Contrac)

5.2.1.1 Analog / digital



Important

For more information regarding footnote 1) see chapter **Electrical connection**, page 17.



Important

The electrical connection is provided by terminals on the actuator and on the electronic unit.

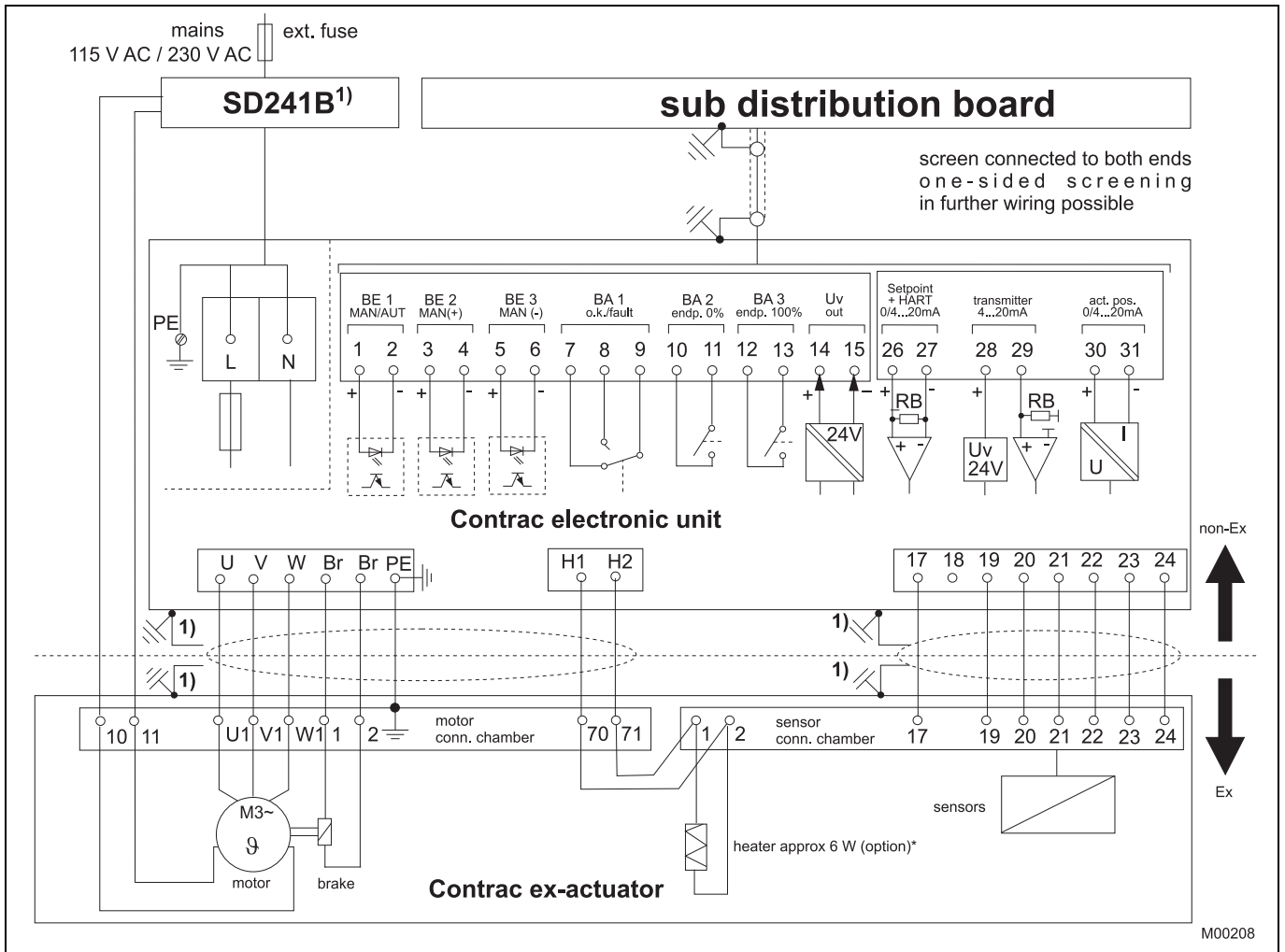

Fig. 10: Electrical connection: Ex actuator analog / digital

M00208

Electrical connection

5.2.1.2 PROFIBUS DP

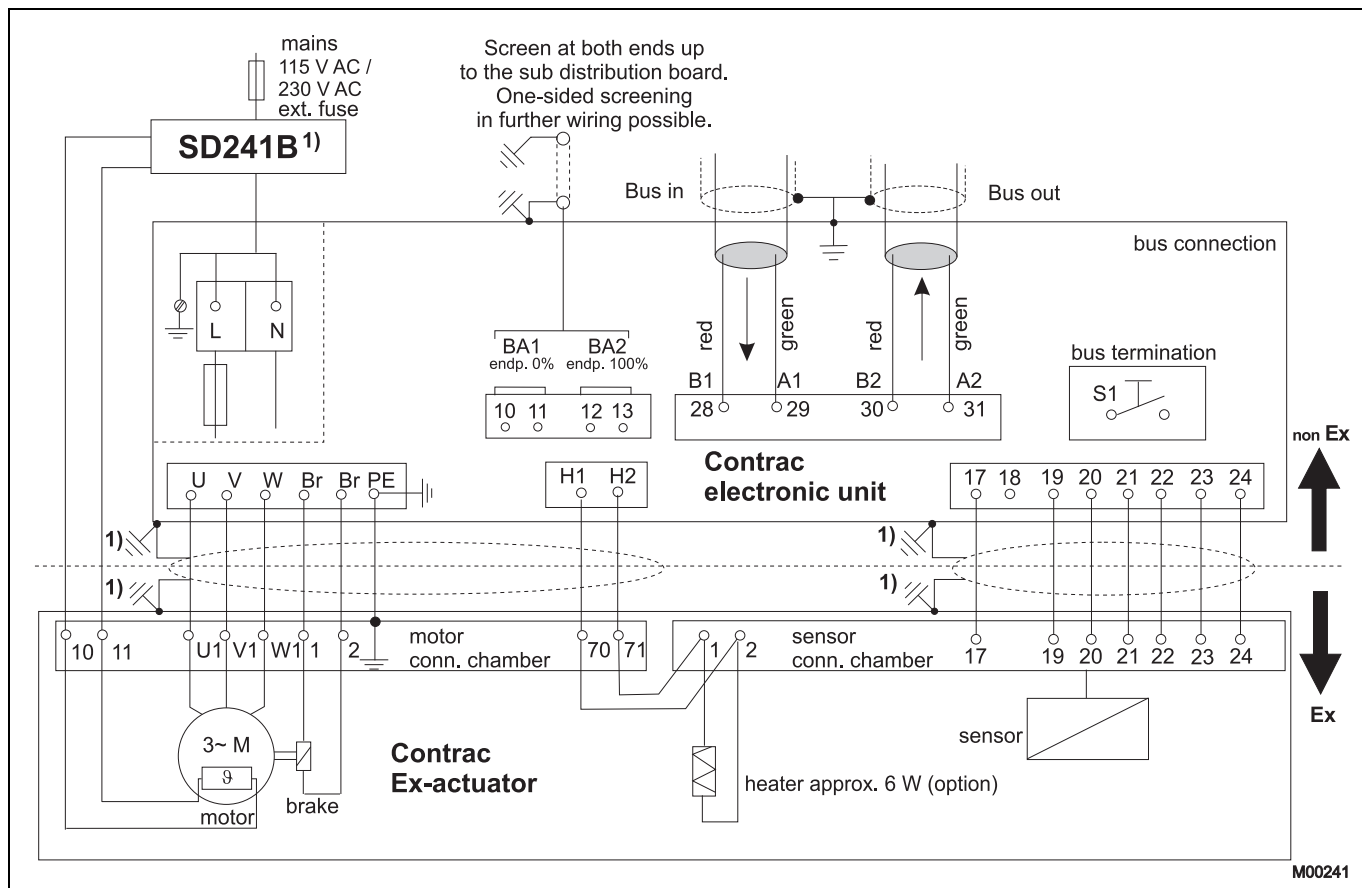

Fig. 11: Electrical connection: PROFIBUS DP option

5.2.2 Power Electronic Unit EBN861 (Contrac)

5.2.2.1 Analog / digital



Important

For more information regarding footnote 1) see chapter **Electrical connection**, page 17.



Important

The electrical connection is provided by terminals on the actuator and on the electronic unit.

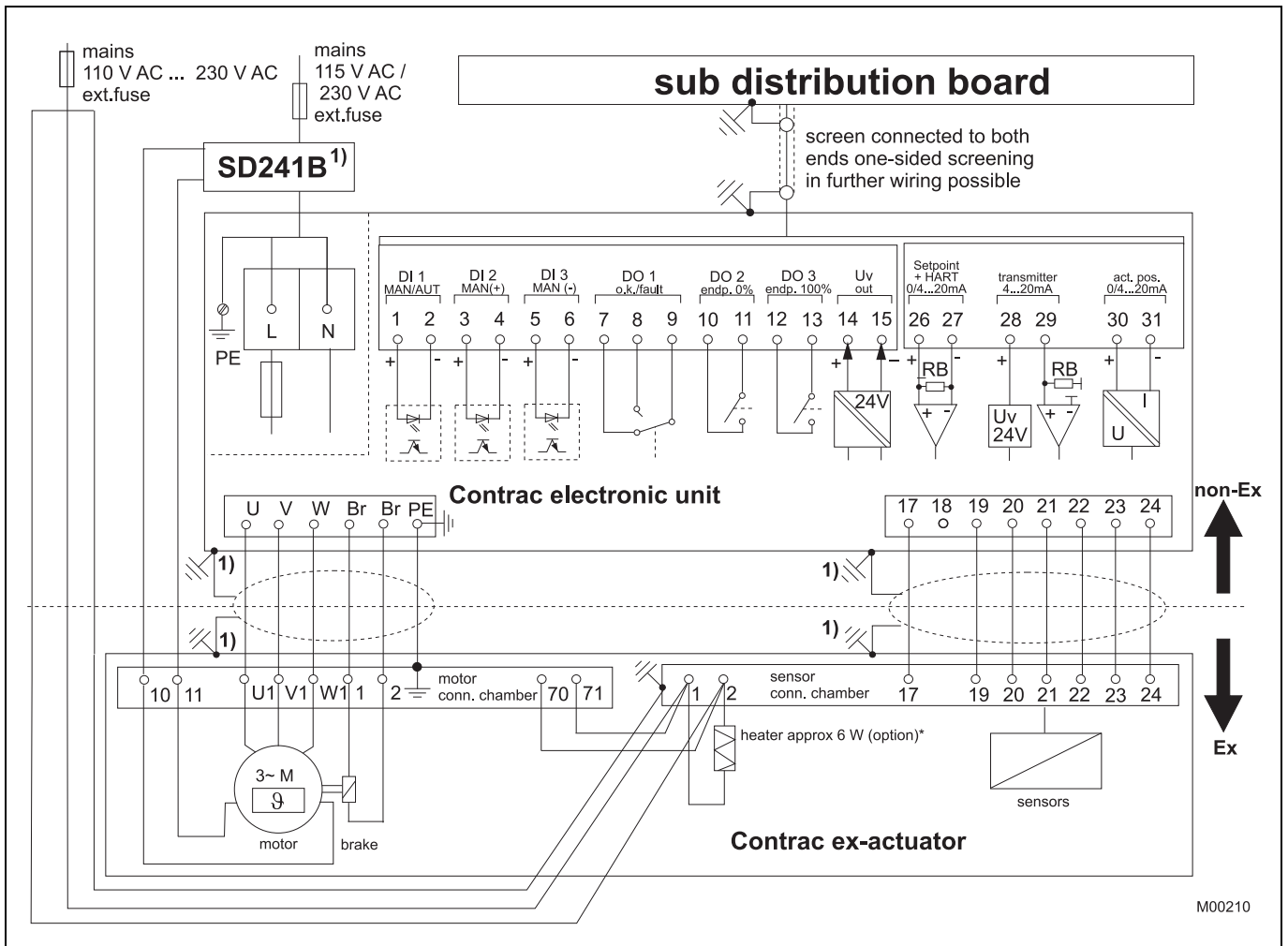

Fig. 12: Electrical connection: Ex actuator analog / digital



Important

* For separate heat supply, protect the heater with 2 ... max. 6 A medium time-lag fuses (e.g., Neozed D01CE14).

Electrical connection

5.2.2.2 PROFIBUS DP

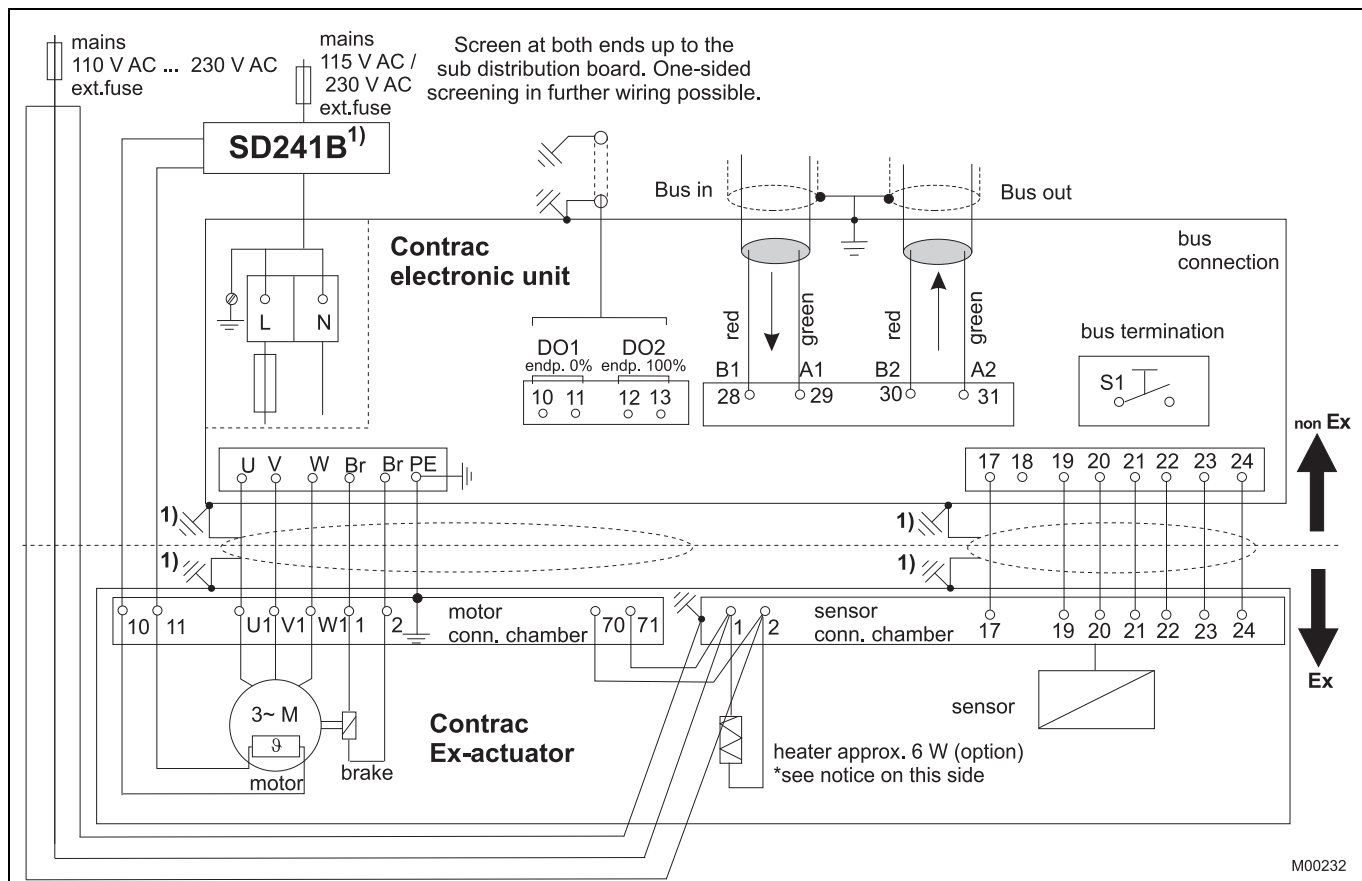

Fig. 13: Electrical connection: PROFIBUS DP option



Important

* For separate heat supply, protect the heater with 2 ... max. 6 A medium time-lag fuses (e.g., Neozed D01CE14).

5.2.3 External fuse for EBN861

In addition to the internal fuses, the EBN861 power electronic unit needs two other external fuses, which are delivered separately with the module.

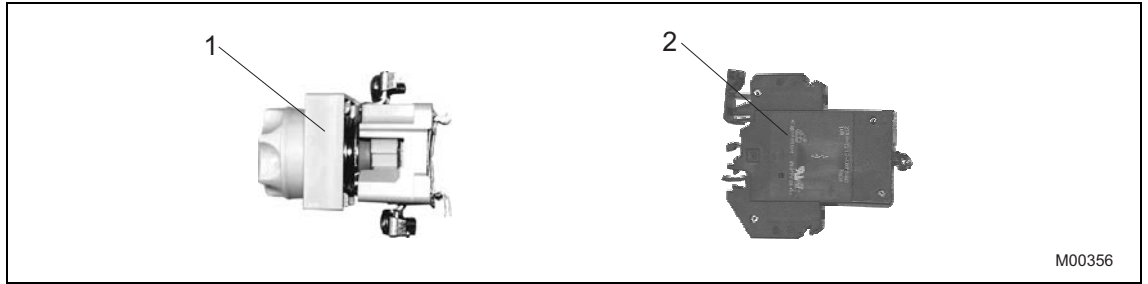

Fig. 14

- 1 External fuse: 35 A
- 2 External fuse: 16 A

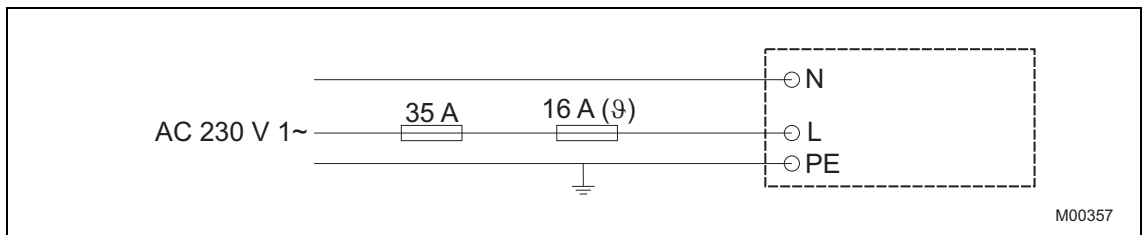

Fig. 15

5.3 Configuration of digital input/output signals

To control the actuator via digital input 1, the unit must be switched to AUTO mode:

- The digital inputs can be enabled via the user interface in the configuration software (standard configuration).
- AUT can be enabled via the user interface in the configuration software (standard, factory-default configuration)

5.3.1 Standard

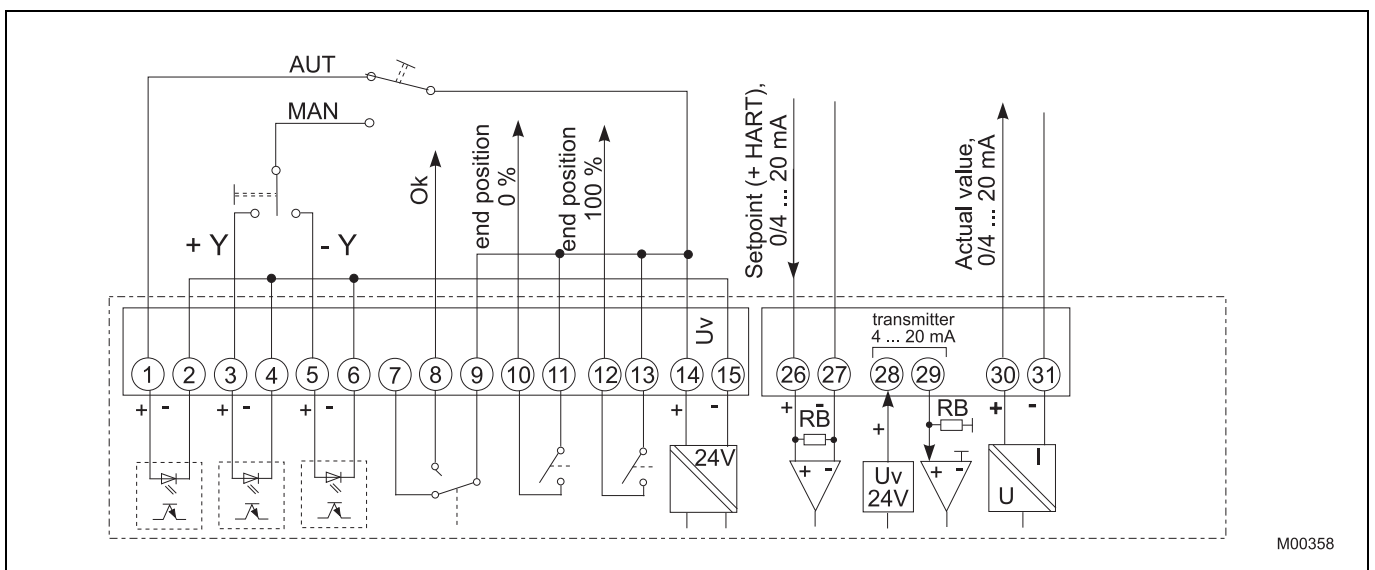

Fig. 16: Potential wiring for default assignments

Local operation

5.3.2 Downstream from step controller

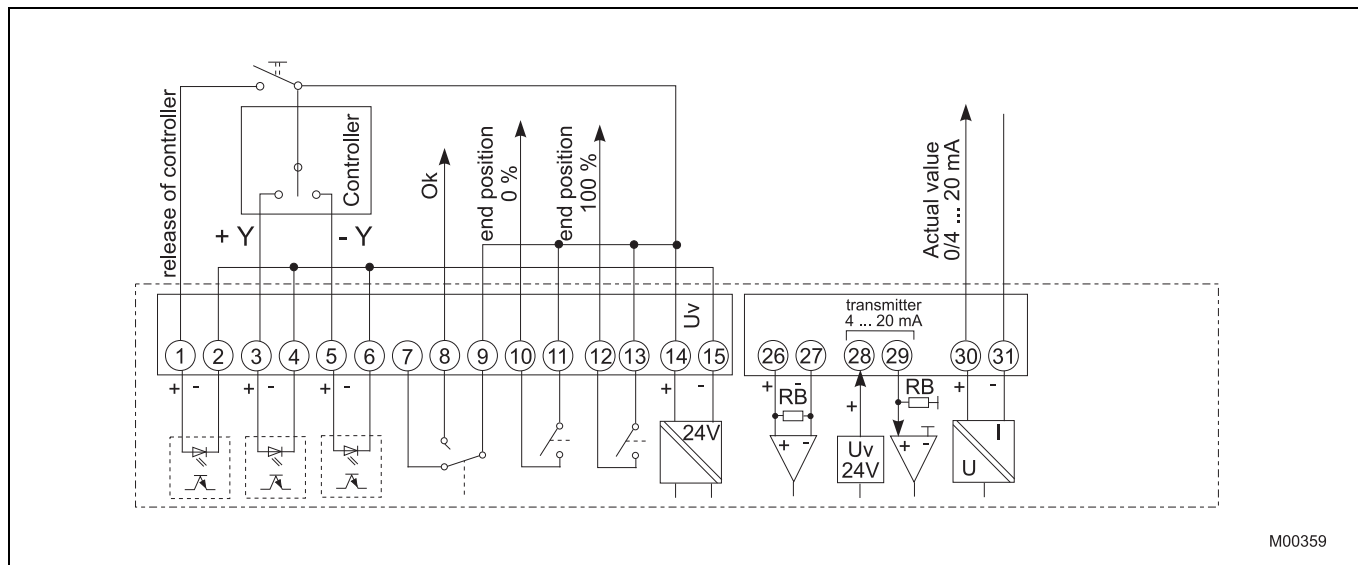

Fig. 17: Potential wiring for "Downstream from step controller" operation

Positions for the potential switch

(See page 25 Fig. 18: pos. 8)

Name:	INT ⊥
Position A:	SYS ⊥
Position B:	⊥



Important

In this operating mode, the switch for the reference potential must be in position ⊥.

6 Local operation

6.1 General information on operation

The basic settings "Define end positions" and "Initial diagnosis" can be configured via the commissioning and service field (ISF). It can be used to adjust the actuator to the working area and set the direction without using a PC. The actuator can be further parametrized using a graphic user interface.



Important

The commissioning and service field is located on the electronic unit.



Important

Observe the information about using the engineering software Save & Restore or ECOM688 in chapter 2.2.

6.2 Operating elements of the service field (ISF)

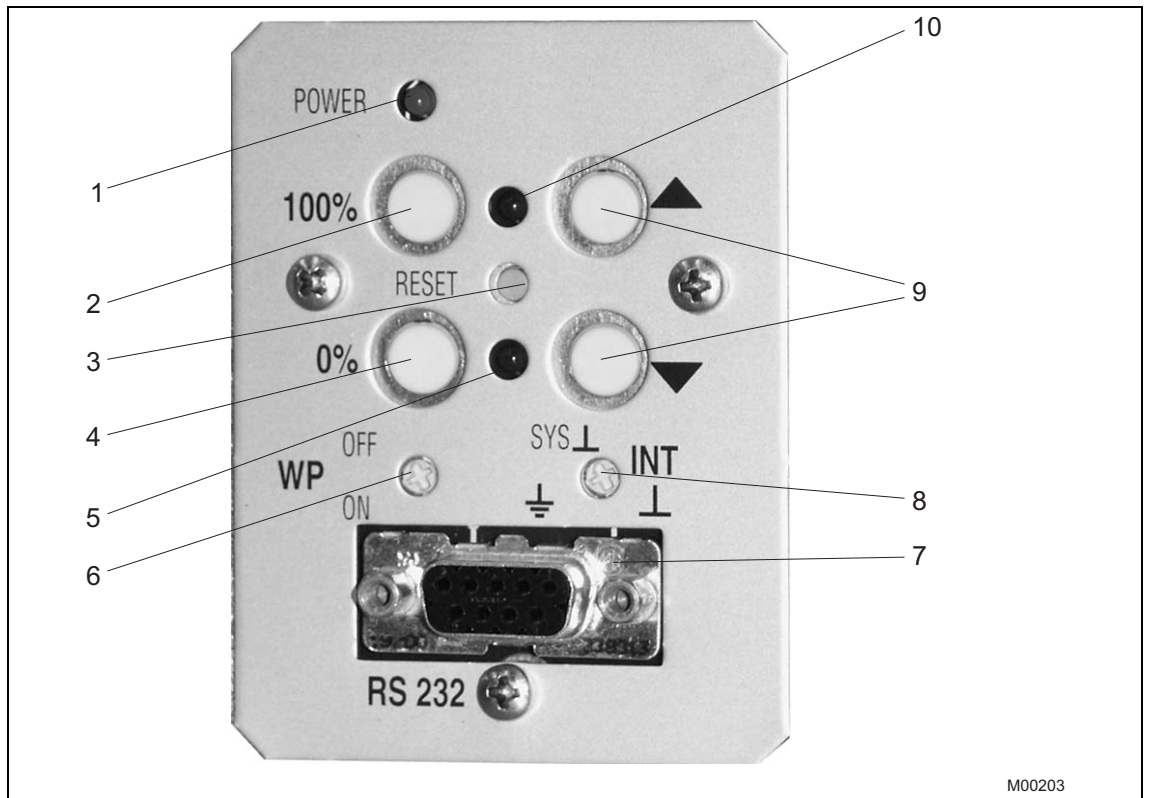

Fig. 18: Commissioning and service field (ISF)

- | | |
|---|---|
| <ul style="list-style-type: none"> 1 Power LED: Displays supply by line voltage. 2 Accept button (100%): Press to set the current position as 100 %; press in combination with the 4 button to end the adjustment process. 3 Reset button: Press to restart the processor and delete any values assigned positions 0% and 100%. 4 Accept button (0 %): Press to set the current position as 0%; press in combination with the 2 button to end the adjustment process. 5 LED for 0% position: Depending on the flash rate, this LED indicates either adjustment, position saved or error. | <ul style="list-style-type: none"> 6 Write-protection switch (default: ON). 7 RS232 connector: Connection for a PC. 8 Potential switch: Connection of reference potential either to system or protective ground (default setting: to system). 9 Travel button: Press to initiate actuator movement. 10 LED for 100 % position: Depending on the flash rate, this LED indicates either adjustment, position saved or error. |
|---|---|

7 Commissioning and service field (ISF)

7.1 Typical commissioning with the service field (ISF)



Important

The operating range of the actuator is not adjusted at time of delivery. To configure the unit, switch the write protection to "OFF". After commissioning, switch the write protection to "ON".

For information on setting up the mechanical end stops, refer to the operating instructions of the relevant actuator.

Part of the commissioning activities below can only be performed by opening the cover flap of the ISF.



Danger – Serious damage to health / risk to life

Make sure that the actuator can move without danger.

7.1.1 Opening the cover flap of the ISF

1. Release the screws for the cover flap.
2. Swing the cover flap to the side.

7.1.2 Status

- The electronic unit is connected to the power supply and wired to the actuator.
- Move the write protection (6) to the "OFF" position.
- The electronic unit is in the MAN operating mode; no signal at digital input 1 (DI 1).
- No error (if an error exists, the LEDs flash alternately at 4 Hz).

7.1.3 Operating mode "Device setup"

3. Switch the electronic unit to the "Device setup" operating mode. Press and hold both travel buttons (9) at once for approx. 5 s until both LEDs (items 5 and 10 in **Fig. 18**) flash in sync at a rate of 4 Hz.



Important

After commissioning, switch the write protection to "ON".

7.1.4 Setup via user interface

Context-sensitive online Help can be called at any time via the graphical user interface.



Important

The RS232 communication cable provides a conductive ground connection between the computer and the Contrac electronic unit. If the PC is grounded, a ground loop may form in the system.

7.1.5 Defining the initial position (0% or 100%)

4. Use a travel button (9) to move to the desired position.
5. Press the Accept button (2) or (4) to accept the position; if successful, the corresponding LED flashes at a rate of 1 Hz. The other LED continues to flash at approx. 4 Hz.

7.1.6 Defining the second position (0% or 100%)

6. Use a button (9) to move to the second position.
7. To accept the position, press the Accept button (2) or (4). If successful, both LEDs(5) and (10) flash at a rate of approx. 1 Hz.

7.1.7 Saving your settings

8. Press both Accept buttons (2 + 4) to accept the settings. The LEDs (5 + 10) stop flashing after a short period of time and the adjustment process is completed.
9. If the range selected for the actuator is too small, both LEDs begin to flash again at 4 Hz and the setup procedure must be repeated with a larger value (min. actuator travel).
(Information regarding actuator travel on the model plate)

7.1.8 Correcting settings

- If after accepting the initial value for the settings you need to correct this value, press the reset button (3) and repeat the settings.
- If you need to make corrections after saving, the complete setup procedure must be performed again.

Function	Signals
Device setup	
Switch to Device Setup: Press and hold both travel buttons for approx. 5 s.	Both LEDs then flash in sync at 4 Hz.
Reaching an end position: Use the appropriate button on the ISF.	Both LEDs continue to flash at 4 Hz during actuator travel.
Save the initial end position: Press 0 % or 100 %.	The corresponding LED flashes at approx. 1 Hz, the others continue to flash at 4 Hz.
Save the second end position: Press 0 % or 100 %.	The related LED flashes at approx. 1 Hz in sync with the first LED.
Finish Adjustment: Press 0 % and 100 % at once.	Both LEDs light up briefly and then stop flashing.
Operation	
Standard operation: MAN / AUT	The LEDs are switched off.
Positioning via the button on the ISF takes priority over the control system.	The LEDs are switched off.
Error (both LEDs flash alternately at 4 Hz)	
Reset: Resets error messages.	If no other error exists, both LEDs stop flashing.
Reset if the operating range is overshoot: Hold both travel buttons for 5 s and then press the Reset button.	After approx. 5 s, the flashing is briefly interrupted. After a reset, the electronic unit will be in adjustment mode.



Important

After startup, it is recommended that you use the control system to operate the actuator and check the behavior as well as signaling of the actuator.

To place the actuator in automatic mode after startup, a 24 V DC signal at the digital input 1 must be present for actuators with active digital input functions (default setting).

If the digital function is switched off, the actuator switches to automatic mode immediately after completing the adjustment process.

8 Alarms / Errors

8.1 Definition

8.1.1 Alarms

The actuator or electronic unit is in a critical state (e.g., high temperature), which currently does not affect the actuator, electronic unit, process or persons. The actuator functions are available. Previous alarms are stored in the "Saved Alarms" area in the electronic unit. Use the graphic user interface to output the stored alarms.

8.1.2 Error

The actuator or electronic unit is in a critical state, e.g., positioning time-out, which currently is impairing the actuator, electronic unit, process or persons. The actuator is switched off and the actuator functions are no longer available. Previous error messages are stored in the "Saved Errors" area in the electronic unit. Use the graphic user interface to output the stored errors. Error messages cannot be reset until the cause of the error has been eliminated.

8.2 Alarm diagram

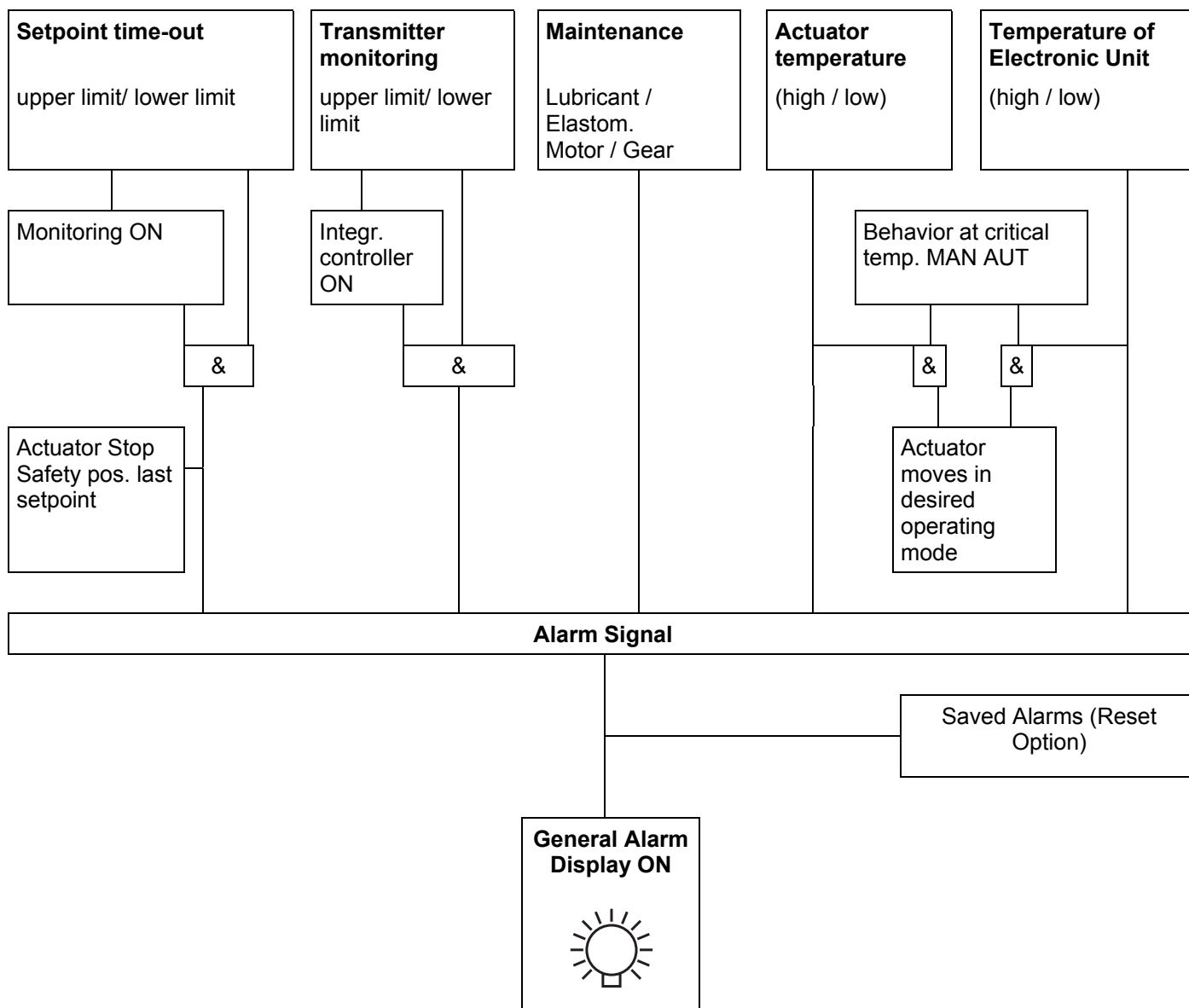

8.3 Error diagram

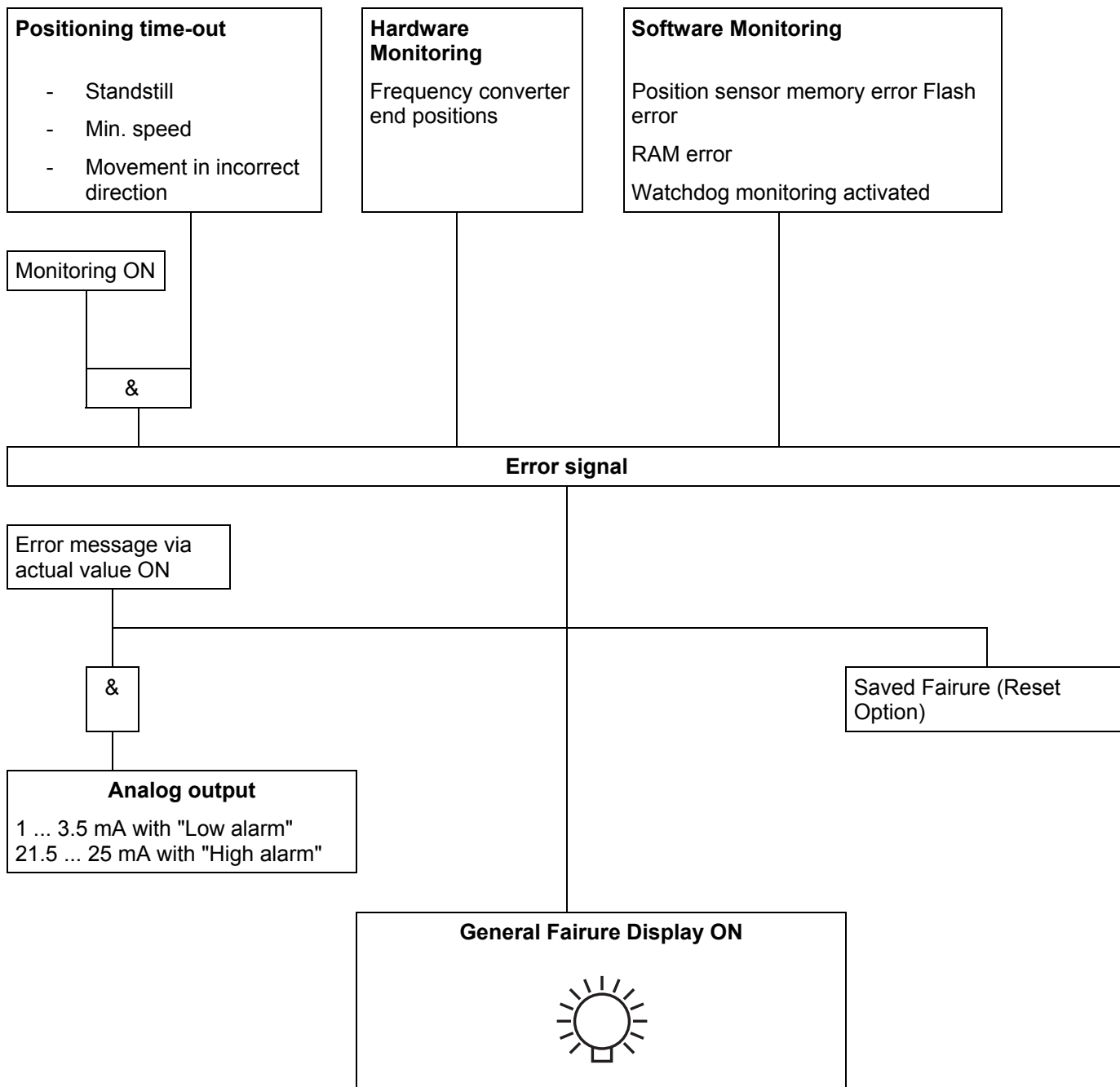

9 Trouble shooting

This chapter only covers failures caused by the hardware. Use the online-help of the configuration software for an extended troubleshooting.

failure pattern	possible reason	troubleshooting
actuator can not move the valve	failure either at the actuator or at the final control element (e.g., stuffing box tightened too much)	detach actuator from valve if the actuator moves the valve is the possible cause if the actuator does not run, the actuator is the possible cause
actuator does not react	incorrect electronic unit or incorrect data set	Compare the nameplate data on the actuator and electronic unit.
	Incorrectly configured electronic unit	Check/update the settings for the parametrization software
	no communication with the control system	Check wiring
	incorrect wiring between actuator and electronic unit	Check wiring
	motor / brake faulty	Check the winding resistance of the motor and brakes Check the brake lock
	Binary inputs on the electronic unit are not wired	Make connection
	Brake does not release (no mechanical "click")	Check the brake air gap (approx. 0.25 mm) and electrical connection to the brake check winding resistance of the brake coil
actuator does not run in AUT mode, although "AUT" is selected in the user interface	Binary input 1 (BE 1) not wired	Make connection Check the software settings for the binary inputs
LEDs in the commissioning and service panel (CSP) flash synchronously	Actuator is not adjusted properly	Adjust actuator
LEDs flash alternately	Electronic unit / drive failure	drive the actuator beyond the adjusted end position (either manually or using the push buttons on the CSP); <:hr>(if necessary disconnect from valve or damper)
failure when approaching the end position	Actuator in limit range of positioning sensor	drive the actuator back into the operating range and connect it to the valve / damper re-adjust the operating range

10 Technical data

10.1 Power Electronic Unit EBN853 (Contrac)

Power Electronic Unit EBN853 (Contrac)	
Protection Class	IP 66
Humidity	≤ 95% average; condensation not permitted
Ambient temperature	-25 ... 55 °C (-15 ... 130 °F)
Mounting position	at vertical support, cable gland at the left side
Coating	2-layer component epoxy (RAL 9005, black)
Cable between actuator and electronic unit	optional 5 m (16 ft), 10 m (32 ft) or 20 m (65 ft) with plug for connection to the actuator; max. cable length between actuator and electronic unit: 100 m (328 ft). No plug connection for explosion-proof actuators (RSDE ... / RHDE ...). Optional, loose cable set supply acc. to length requirements
Weight; approx.	11 kg (24 lbs)

Supply voltage (standard actuators)	115 V AC (94 ... 130 V) or 230 V AC (190 ... 260 V); 47.5 ... 63 Hz; 1Ph			
Supply voltage (Ex actuators)	115 V AC (94 ... 127 V) or 230 V AC (190 ... 253 V); 47.5 ... 63 Hz; 1Ph			
Current at electronic unit [A] (115 V AC / 230 V AC)		I_{max} at 115V	I_{max} at 230V	$I_{pos. (115V + 230 V)}$ approx. 40 ... 50% of I_{max}
	RHD(E)250-10	1,8 A	0,9 A	
	RHD(E)500-10	2,2 A	1,1 A	
	RHD(E)800-10	5,0 A	2,5 A	
	RHD(E)1250-12	5,0 A	2,5 A	
	RHD(E)2500-25	5,0 A	2,5 A	
	RHD(E)4000-40	5,8 A	2,7 A	
	RHD(E)8000-80	5,0 A	2,5 A	
	RSD(E)10-5.0	2,2 A	1,1 A	
	RSD(E)10-10,0	3,6 A	1,8 A	
	RSD(E)20-5.0	3,6 A	1,8 A	
	RSD(E)20-7,5	4,8 A	2,4 A	
	RSD(E)50-3,0	5,0 A	2,5 A	
RSD100-1.5	5,0 A	2,5 A		
RSD200-0,7	5,0 A	2,5 A		
External fuse	16 A; time-lag			

10.2 Power Electronic Unit EBN861 (Contrac)

Power Electronic Unit EBN861 (Contrac)	
Protection Class	IP 66
Humidity	≤ 95% average; condensation not permitted
Ambient temperature	-25 ... 55 °C (-15 ... 130 °F)
Mounting position	at vertical support, cable gland at the bottom
Coating	2-layer component epoxy (RAL 9005, black)
Cable between actuator and electronic unit	optional 5 m (16 ft), 10 m (32 ft) or 20 m (65 ft) with plug for connection to the actuator; max. cable length between actuator and electronic unit: 100 m (328 ft) No plug connection with RSDE... / RHDE... actuators; optional, loose cable set supplied acc. to length requirements
Weight; approx.	40 kg (88 lbs)

Supply voltage (standard actuators)	230 V AC (190 ... 260 V); 47,5 ... 63 Hz; 1Ph		
Supply voltage (Ex actuators)	230 V AC (190 ... 253 V); 47,5 ... 63 Hz; 1Ph		
Current at electronic unit [A] (230 V AC)		I_{max} at 230V	$I_{pos. (230 V)}$ approx. 40 ... 50% of I_{max} .
	RHD(E)2500-10	5,3 A	
	RHD(E)4000-10	10,0 A	
	RHD8000- 12	8,0 A	
	RHDE8000-15	8,0 A	
	RHD(E)16000-30	12,5 A	
	RSD(E)50- 10	6,4 A	
	RSD100-10,0	12,5 A	
	RSD200-5.0	13,0 A	
External fuse	safety fuse 35 A (Lindner) + thermal circuit breaker 16 A (ETA) fuse and circuit breaker are part of shipment		

11 Appendix

11.1 Permits and certifications

	Symbol	Description
CE mark		<p>The CE mark indicates that the device complies with the following directives and their basic safety requirements:</p> <ul style="list-style-type: none">• CE mark on the nameplate of actuator.<ul style="list-style-type: none">– Conforms with EMC directive 89/336/EEC.– Conforms with the machinery directive 2006/42/EC. <p>By placing the CE mark on its devices, ABB Automation Products GmbH declares its conformance with these directives.</p>



Important

All documentation, declarations of conformity and certificates are available in the download area of ABB Automation Products GmbH.

www.abb.com/instrumentation

Statement about the contamination of devices and components

The repair and/or maintenance of devices and components will only be performed when a completely filled out explanation is present.

Otherwise, the shipment can be rejected. This explanation may only be filled out and signed by authorized specialist personnel of the operator.

Customer details:

Company: _____

Address: _____

Contact person: _____

Telephone: _____

Fax: _____

E-Mail: _____

Device details:

Type: _____

Serial no.: _____

Reason for the return/description of the defect: _____

_____**Was this device used for working with substances which pose a threat or health risk?** Yes No

If yes, which type of contamination (please place an X next to the applicable items)

biological	<input type="checkbox"/>	corrosive/irritating	<input type="checkbox"/>	combustible (highly/extremely combustible)	<input type="checkbox"/>
toxic	<input type="checkbox"/>	explosive	<input type="checkbox"/>	other harmful substances	<input type="checkbox"/>
radioactive	<input type="checkbox"/>				

Which substances have had contact with the device?

1. _____

2. _____

3. _____

We hereby certify that the devices/parts shipped were cleaned and are free from any dangerous or poisonous materials.

City, Date_____
Signature and company stamp

12 Index

A	
Alarm diagram.....	29
Alarms.....	29
Alarms / Errors.....	29
Appendix.....	34
C	
Cable shield.....	18
CE mark.....	34
Commissioning and service field (ISF).....	26
Configuration of digital input/output signals.....	23
Contrac electronic unit.....	17
D	
Design and function.....	12
Disposal.....	9
Downloads.....	34
E	
EBN853.....	13, 15
EBN861.....	14, 16
ECOM688.....	11
Electrical installation safety information.....	10
EMC directive.....	34
Error.....	29
Error diagram.....	30
Ex applications.....	17
Explosion-protection safety precautions.....	11
F	
Factory default.....	15
G	
General information on operation.....	24
General Safety Information.....	5
I	
Installation.....	15
Installation safety information.....	10
Installing the housing halves.....	16
L	
Labels and symbols.....	6
Local operation.....	24
M	
Modules.....	13
Motor.....	18
Mounting.....	16
N	
Name plate.....	7
O	
Operating elements of the service field (ISF).....	25
Operating safety information.....	11
Operation via frequency transformer.....	11
Operator liability.....	8
P	
Permits and certifications.....	34
Personnel qualification.....	8
Power Electronic Unit EBN853 (Contrac).....	19, 32
Power Electronic Unit EBN861 (Contrac).....	21, 33
PROFIBUS DP.....	20, 22
Proper use.....	5
R	
Returning devices.....	9
S	
Safety.....	5
Separating the housing halves.....	16
Storage conditions.....	10
Symbols and warnings.....	6
T	
Technical data.....	32
Technical limits.....	5
Terminal connection diagrams.....	19
Transport safety information.....	9
Trouble shooting.....	31
Typical commissioning with the service field (ISF).....	26
W	
Warranty provision.....	6
WEEE directive.....	9

ABB has Sales & Customer Support
expertise in over 100 countries worldwide.

www.abb.com/instrumentation

The Company's policy is one of continuous product
improvement and the right is reserved to modify the
information contained herein without notice.

Printed in the Fed. Rep. of Germany (02.2008)

© ABB 2008

3KXE181001R4201



ABB Limited

Salterbeck Trading Estate
Workington, Cumbria
CA14 5DS

UK

Tel: +44 (0)1946 830 611

Fax: +44 (0)1946 832 661

ABB Inc.

125 E. County Line Road
Warminster, PA 18974
USA

Tel: +1 215 674 6000

Fax: +1 215 674 7183

ABB Automation Products GmbH

Schillerstr. 72
32425 Minden
Germany

Tel: +49 551 905-534

Fax: +49 551 905-555

CCC-support.deapr@de.abb.com