

FXP4000 (PARTI-MAG II) Electromagnetic Flowmeter Model DP41F and DP46F



**For full and partially full pipelines
(free and surface pipelines)**

**Precise measurement of the flowrate of liquids
and slurries with electrical conductivities of at
least 50 mS/cm up to 10 mS/cm**

- High accuracy also with partially for full pipes

**Especially suitable for flow metering in partially full
pipelines (e. g. for rain retention basins, clarifier
in- and outflow)**

- In the partially full flow regime it is unaffected by backflow
- Short in- and outlet straight sections: 5 x DN upstream
and 3 x DN downstream of the meter
- Minimum required fill level 10 % of the flowmeter diameter

Meter size range from DN 150 to DN 2000

User friendly parameter entry directly at the converter

Factory calibrated

**Automatic system monitoring with error diagnostics
in clear text plus an output alarm signal**

Absolute zero stability

Maximum measuring error

- With partially for full pipes: 3 % or 5 % of rate
- With full pipe: 1 % of rate

Accuracy, Reference Conditions and Functional Description

Reference Conditions Based on EN 29104

Fluid Temperature
20 °C (68 °F) ± 2 K

Ambient Temperature
20 °C (68 °F) ± 2 K

Supply Power
Line voltage per Instrument Tag $U_N \pm 1 \%$

Straight Pipe Installation Requirements
Upstream >10 x DN,
Downstream > 5 x DN,
DN = Flowmeter primary diameter

Warm Up Time
30 min

Accuracy: (Pulse Output)

- **Full Pipe**
 - $Q > 0.04 Q_{maxDN}$ 1 % of rate
 - $Q < 0.04 Q_{maxDN}$ 0.0004 Q_{maxDN}
- **Partially Full Pipe**
($v > 0.2 \text{ m/s}$); ($h > 0.1 \times DN$)
(for DN 150 only: $h > 0.15 \times DN$)
 - $Q > Q_{\dot{u}}$ 3 % of rate
 - $Q_{min} < Q < Q_{\dot{u}}$ 5 % of rate
where $Q_{\dot{u}} = 0.02 Q_{maxDN}$ and $Q_{min} = 0.001 Q_{maxDN}$
(For values of Q_{maxDN} see Table Page 3)

Current Output Effects

Same as pulse output plus ± 0.1 % of rate

Functional Description

The basis for the electromagnetic flowmeter is Faraday's law of induction. A conductive fluid flows through a pipe perpendicular to the direction of a magnetic field (see Fig. 2).

$$U_E \sim B \cdot D \cdot v$$

The voltages generated in the fluid are measured by a number of electrodes pairs. They are arranged in the meter tube in such a manner that for each cross sectional flow area (full or partially full) the electrode pair with the optimal weighting factor is utilized for the measurements. One additional electrode is integrated for full pipe detection.

In addition to the optimized measurement of the average flow velocity the four electrode pairs are also utilized for determining the fill level through utilization of a superimposed ac field.

The signal voltage U_E is corrected using the partially full characteristic curves stored in the converter and converted into a flowrate proportional output signal.

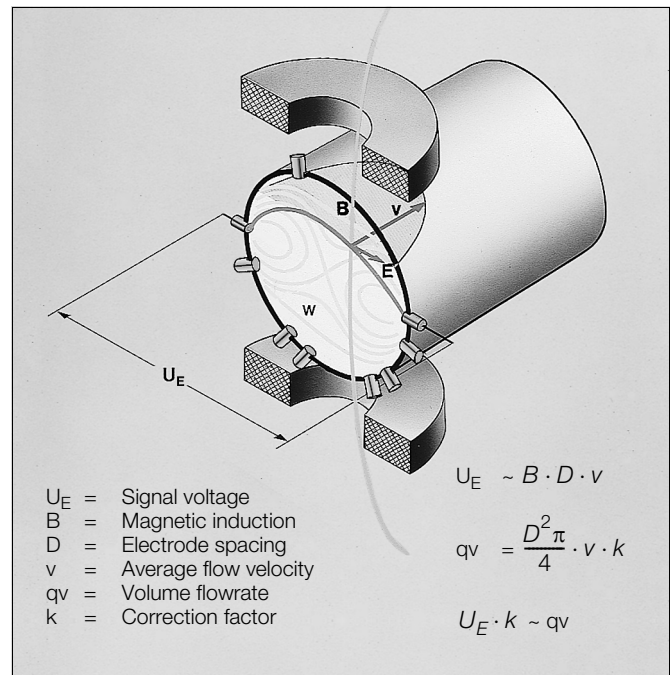

Fig. 2 Measurement Principle

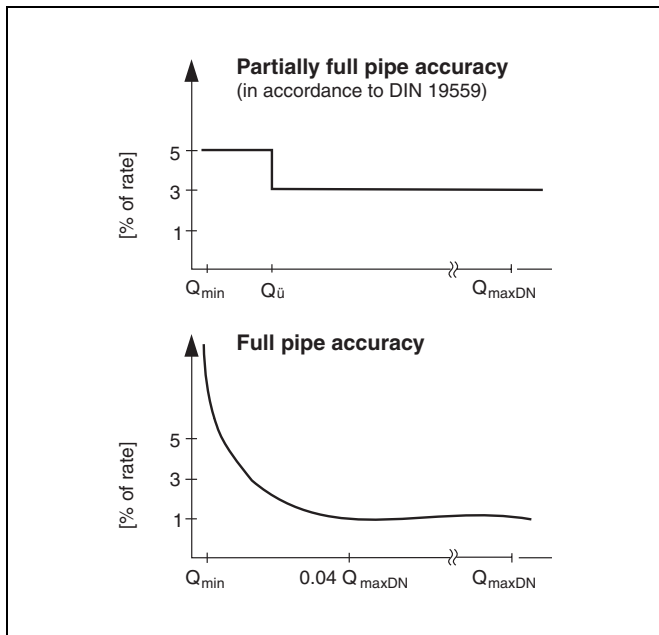

Fig. 1 Accuracy of the FXP4000 (PARTI-MAG II)

Technical Data: Flowmeter Primary



Fig. 3 Flowmeter Primary

Meter Size, Pressure Rating and Flow Ranges

Meter Size DN	Standard Pressure rating PN	Min. Range Setting		Max. Range Setting Q_{maxDN}
150	10/16	0 to	8.33 l/s	0 to 166.7 l/s
200	10/16	0 to	15.0 l/s	0 to 300 l/s
250	10/16	0 to	25.0 l/s	0 to 500 l/s
300	10/16	0 to	33.33 l/s	0 to 667 l/s
350	10/16	0 to	45.83 l/s	0 to 917 l/s
400	10/16	0 to	62.50 l/s	0 to 1250 l/s
500	10	0 to	91.67 l/s	0 to 1833 l/s
600	10	0 to	133.33 l/s	0 to 2667 l/s
700	10	0 to	183.33 l/s	0 to 3667 l/s
800	10	0 to	272.20 l/s	0 to 5000 l/s
900	10	0 to	333.33 l/s	0 to 6667 l/s
1000	10	0 to	375 l/s	0 to 7500 l/s
1200	6	0 to	590 l/s	0 to 11600 l/s
1400	6	0 to	750 l/s	0 to 15000 l/s
1600	6	0 to	1000 l/s	0 to 20000 l/s
1800	6	0 to	1250 l/s	0 to 25000 l/s
2000	6	0 to	1590 l/s	0 to 31700 l/s

Sizing Information

For the selection of the nominal sizes, observe that the meter tube for minimum flow must be at least 10 % filled. Otherwise the nominal size is to be reduced. The filling height at max. flow should be well above 50 %. The filling height at normal flow which occurs most of the time should be above 30 % at minimum. The conductivity must lie in a range from 50 μ S/cm to 10 mS/cm.

For selecting the optimum flowmeter size for your application a sizing program is available on a 3 1/2" disc for IBM compatible PC's. All required calculation values are integrated in the program.



Notice

When the level drops below the minimum allowable value of 10 % of the flowmeter primary diameter, (15 % only for DN 150), an automatic shut off of the output signals occurs.

Flowrate Nomograph for Full Pipelines

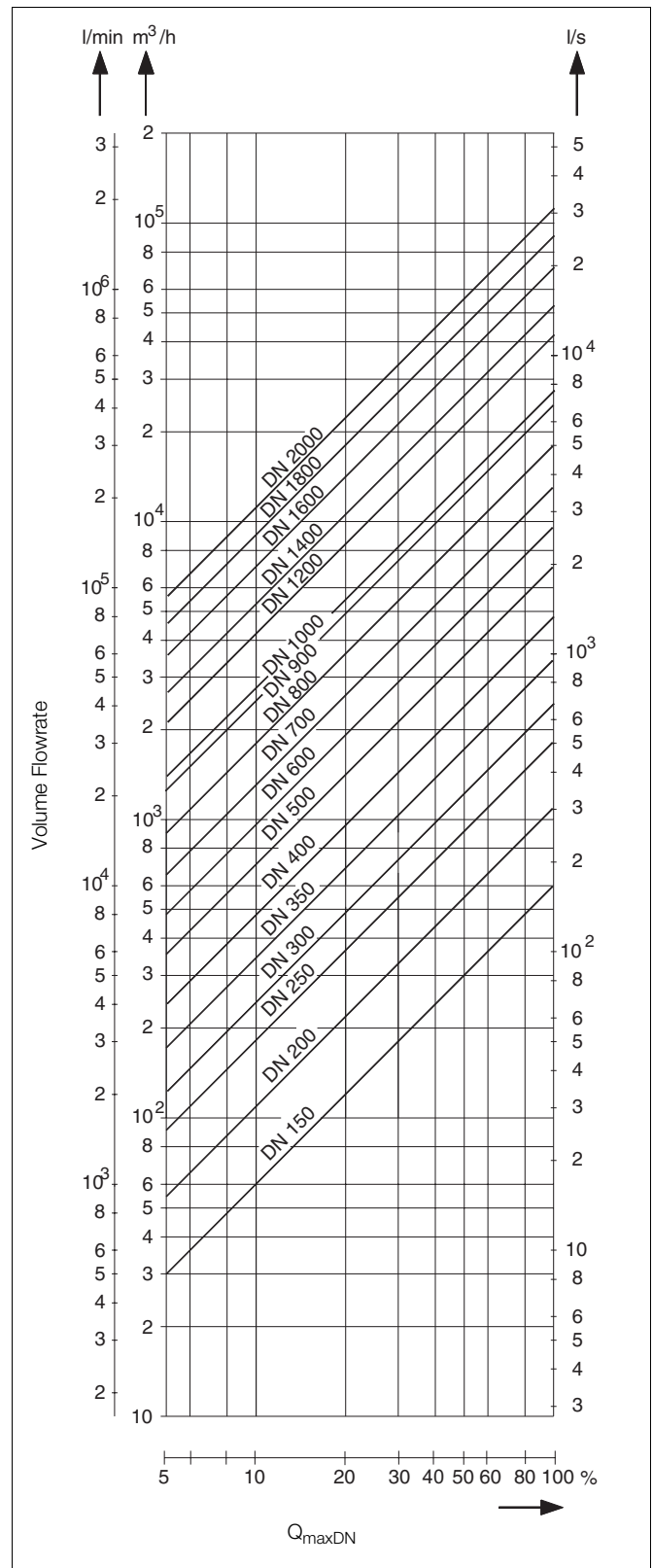

Fig. 4 Flowrate Nomograph for DN 150 to DN 2000

Technical Data Model DP41F, DP46F

Min. allow. Pressure as a function of Fluid Temperature

Liner	Meter Size (6 ... 10")	P _{Operation} mbar abs.	at T _{Operation}
Hard rubber	150 ... 250 (6 ... 10")	0	< 80 °C (176 °F)
	300 ... 1000 (12 ... 40")	0	< 80 °C (176 °F)
Soft rubber	150 ... 250 (6 ... 10")	0	< 60 °C (140 °F)
	300 ... 1000 (12 ... 40")	0	< 60 °C (140 °F)
PTFE KTW approved	150 ... 600 (6 ... 24")	270	< 20 °C (68 °F)
		400	< 80 °C (176 °F)
		500	< 80 °C (176 °F)

Max. Allowable Ambient Temperature as a function of Fluid Temperature

For flowmeters with carbon steel flangers

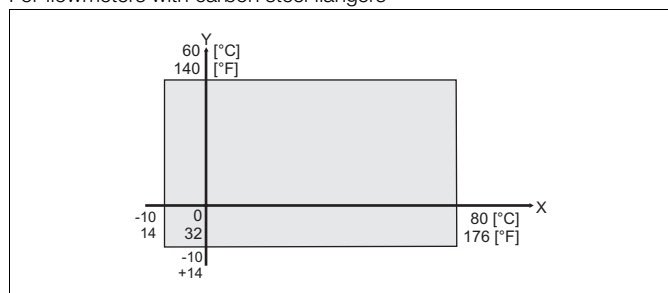

Fig. 5

For flowmeter with stainless steel flangers

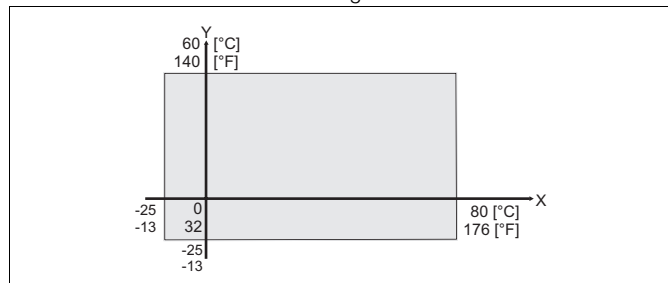

Fig. 6

Y = Ambient temperature °C/°F
X = Fluid temperature °C/°F

Notes regarding min./max. measuring temperature

Liner	Flange material	Min. Temp.	Max. Temp.
Hard rubber	Steel	-10 °C (14 °F)	80 °C (176 °F)
	stainless steel 1.4571	-15 °C (5 °F)	80 °C (176 °F)
Soft rubber	Steel	-10 °C (14 °F)	60 °C (140 °F)
	stainless steel 1.4571	-15 °C (5 °F)	60 °C (140 °F)
PTFE	Steel	-10 °C (14 °F)	80 °C (176 °F)
	stainless steel 1.4571	-25 °C (-13 °F)	80 °C (176 °F)

Materials, Flowmeter Primary

Parts	Standard	Options
Liner	PTFE, PFA, hard rubber, soft rubber	-
Signal and ground electrodes for - Hard rubber - Soft rubber	SS 1.4571 [316Ti]	Hast. B-3 (2.4600), Hast. C-4 (2.4610), Titanium, Tantalum, Platinum-Iridium, 1.4539 [904L]
- PTFE	Hast. C-4 (2.4610)	SS1.4571[316Ti] Hast. B-3 (2.4600) Titanium, Tantalum, Platinum-Iridium, 1.4539 [904L]
Ground plate	SS 1.4571 [316Ti]	Upon request
Protection plate	SS 1.4571 [316Ti]	Upon request

Process Connection Materials

Parts	Standard	Options
Flange DN 150 ... DN 300 (6 ... 12")	Steel (galvanized)	SS1.4571[316Ti]
DN 350 ... DN 1000 (14 ... 40")	Steel (painted)	SS1.4571[316Ti]

Parts	Standard	Options
Housing DN 150 ... DN 300 (6 ... 12")	Two-piece cast aluminum housing, painted, paint coat 60 µm thick, RAL 9002	-
DN 350 ... DN 1000 (14 ... 40")	Welded steel construction, painted, paint coat 60 µm thick, RAL 9002	-
Connection box	Cast aluminium, painted, 60 µm thick, frame: dark gray, RAL7012, cover: light gray, RAL 9002	-
Meter tube	SS 1.4301 [304]	-
PG-Connector	Polyamide	-

Storage Temperature

-20 ... 70 °C (-4 ... 158 °F)

Protection Class per EN 60529

IP 67
IP 68 (optional, max. immersion depth: 5 m)

Pipeline Vibration Following EN 60068-2-6

Converter

- In the range of 10 - 55 Hz max. 0.15 mm deflection

Flowmeter primary

- In the range of 10 - 55 Hz max. 0.15 mm deflection
- In the range of 55 -150 Hz max. 2 g acceleration

Designs

The flanged flowmeters comply with the installation lengths defined in VDI/VDE 2641, ISO 13359 or DVGW (W420, Design WP, ISO 4064 short).

Electromagnetic Flowmeter FXP4000 (PARTI-MAG II)

for Full and Partially Full Pipelines (Free and Surface Pipelines) Model DP41F and DP46F

D184S024U02

Electrical connection

Screw terminals
Cable gland DN 150 ... DN 2000
Excitation cable PG13.5
Signal cable PG21

Explosion protection

Sensor DP46F
II 2 G EEx em [ib] IIC T4,
EC-type Examination Certificate TÜV 97 ATEX 1219X

Ex-Data for model DP46F

The maximum allowable fluid temperatures °C (°F) are listed in the following table as a function of the maximum allowable ambient temperature and the flowmeter size:

Flowmeter size DN	Temperature class	Max. allowable ambient temperature °C (°F)	Max. allowable fluid temperature °C (°F)
150 - 250	T4	60 (140 °F)	80 (176 °F)
150 - 250	T4	50 (122 °F)	80 (176 °F)
150 - 250	T4	40 (104 °F)	80 (176 °F)
300 - 900	T4	60 (140 °F)	80 (176 °F)
300 - 900	T4	50 (122 °F)	80 (176 °F)
300 - 900	T4	40 (104 °F)	80 (176 °F)
1000 - 3000	T4	60 (140 °F)	80 (176 °F)
1000 - 3000	T4	50 (122 °F)	80 (176 °F)

The max. allowable fluid temperature 80 °C (176 °F) is determined by the thermal fuse for the coils.

Allowable ambient temperature primary -20 ... 60 °C (-4 ... 140 °F)

Material load for flanged design model DP41F / DP46F

Limits for the allowable fluid temperature (TS) and allowable pressure (PS) are a function of the liner and flange materials of the flowmeter (see instrument name plate).

Temperature limits

Liner	Flange material	Min. Temp.	Max. Temp.
Hard rubber	Steel	-10 °C (14 °F)	80 °C (176 °F)
	Stainless steel 1.4571	-15 °C (5 °F)	80 °C (176 °F)
Soft rubber	Steel	-10 °C (14 °F)	60 °C (140 °F)
	Stainless steel 1.4571	-15 °C (5 °F)	60 °C (140 °F)
PTFE	Steel	-10 °C (14 °F)	80 °C (176 °F)
	Stainless steel 1.4571	-25 °C (-13 °F)	80 °C (176 °F)

DIN-Flange SS 1.4571 [316Ti] to DN 600 (24")

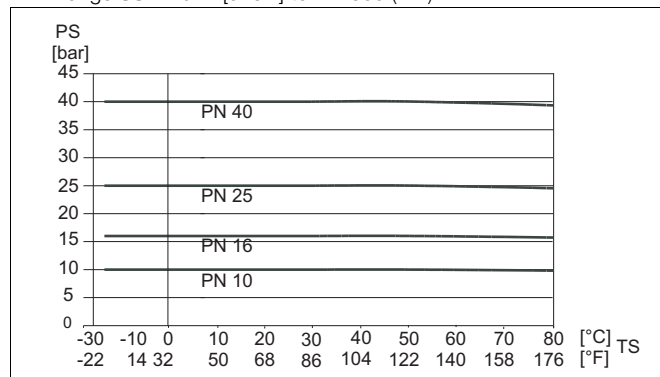

Fig. 7

ASME Flange SS1.4571[316Ti] to DN 300 (12") (CL150/300) to DN 1000 (40") (CL150)

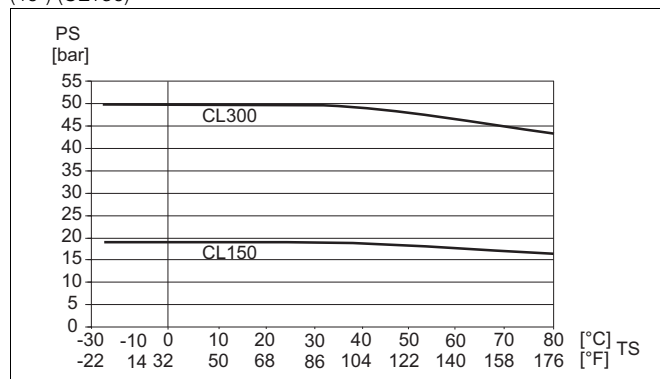

Fig. 8

DIN-Flange Steel to DN 600 (24")

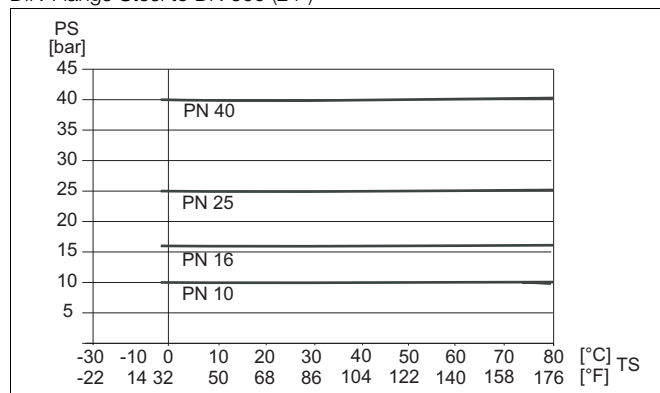

Fig. 9

Electromagnetic Flowmeter FXP4000 (PARTI-MAG II)

for Full and Partially Full Pipelines (Free and Surface Pipelines) Model DP41F and DP46F

D184S024U02

ASME flange carbon steel to DN 300 (12") (CL150/300) to DN 1000 (40") (CL150)

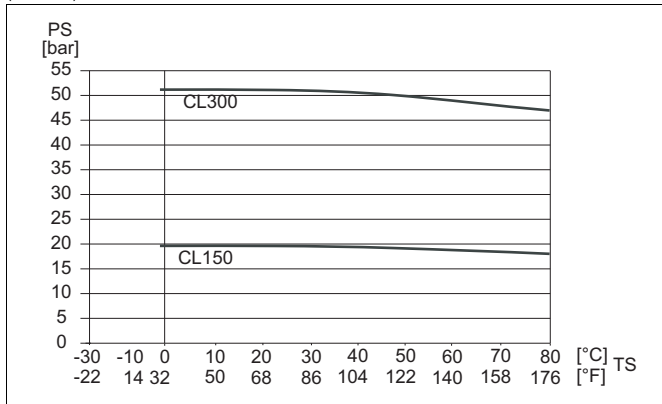

Fig. 10

DIN-Flange carbon steel DN 700 (28") to DN 1000 (40")

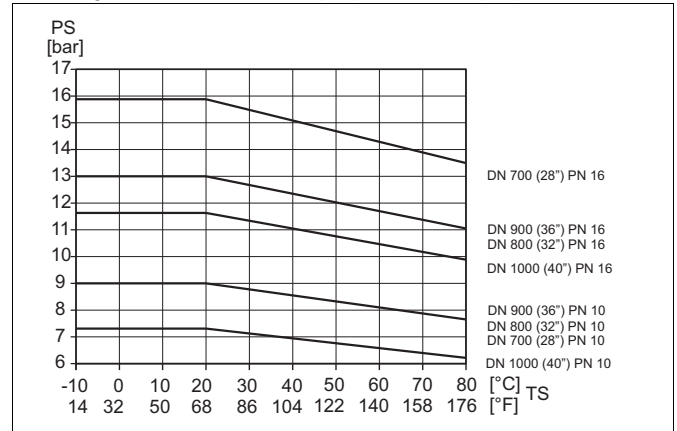

Fig. 12

DIN-Flange SS 1.4571 DN 700 (28") to DN 1000 (40")

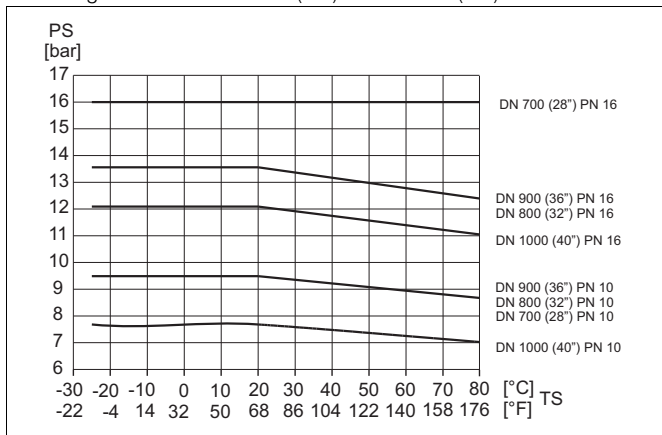
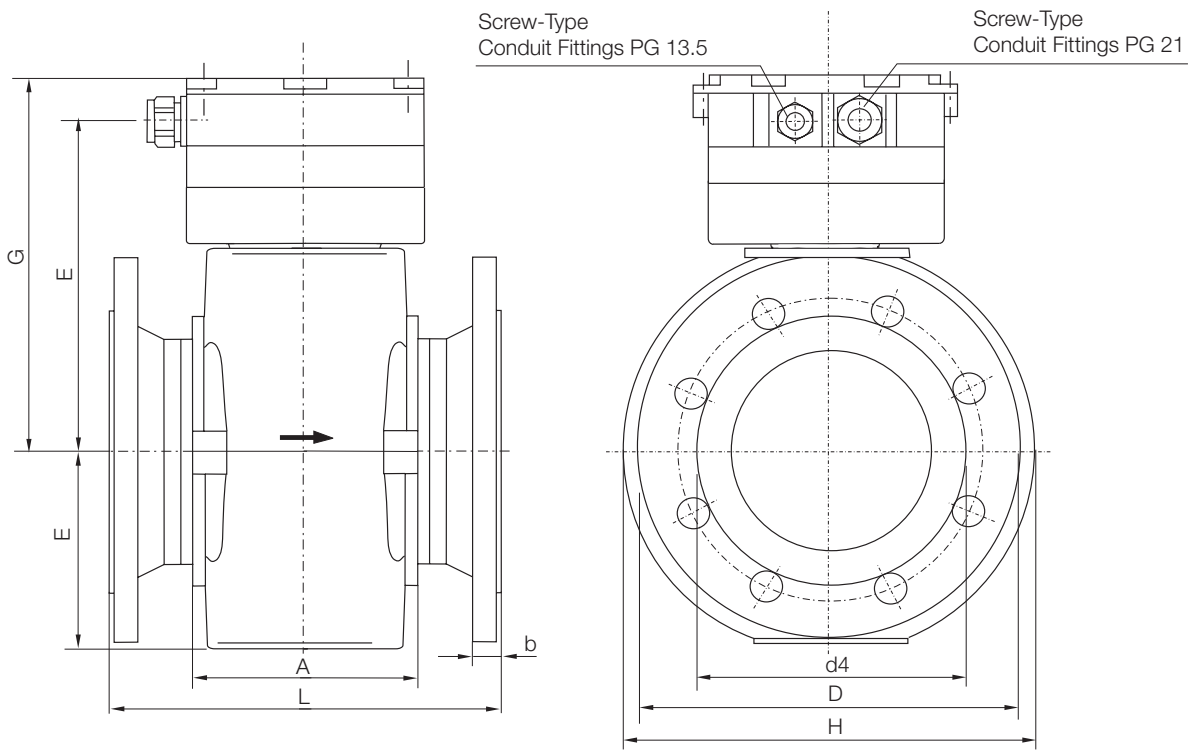
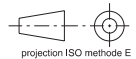

Fig. 11

Dimensional Drawing Flowmeter Primary, DN 150 to DN 250, DIN-flanges



All Dimensions in mm



Flange Dimensions					Instrument Dimensions								Weight approx. kg
DN	PN	D	d4	b	A	L	L ¹⁾	L ²⁾	G	E	F	H	
150	10	285	212	25	170	300	305	310	275	242	148	310	29
	16	285	212	25	170	300	305	310	275	242	148	310	29
200	10	340	268	28	195	350	355	360	315	274	179	340	56
	16	340	268	28	195	350	355	360	315	274	179	340	56
250	10	395	320	30	250	450	455	460	344	301	207	395	82
	16	405	320	30	250	450	455	460	344	301	207	405	82

¹⁾ Standard with one grounding plate SS No.1.4571. Other materials and DN 300 and up upon request. See Note section 9.1 and Footnote Ordering Information Primary.
For hard rubber liners + 2 mm for gasket.

²⁾ With protection flange: Protection flanges provide the ground function, grounding plate not required.
For hard rubber liners + 4 mm for gasket.

Fig. 13 Flowmeter Primary DN 150 to DN 250, DIN-flanges

Dimensional Drawing Flowmeter Primary, DN 300 to DN 1000, DIN-flanges

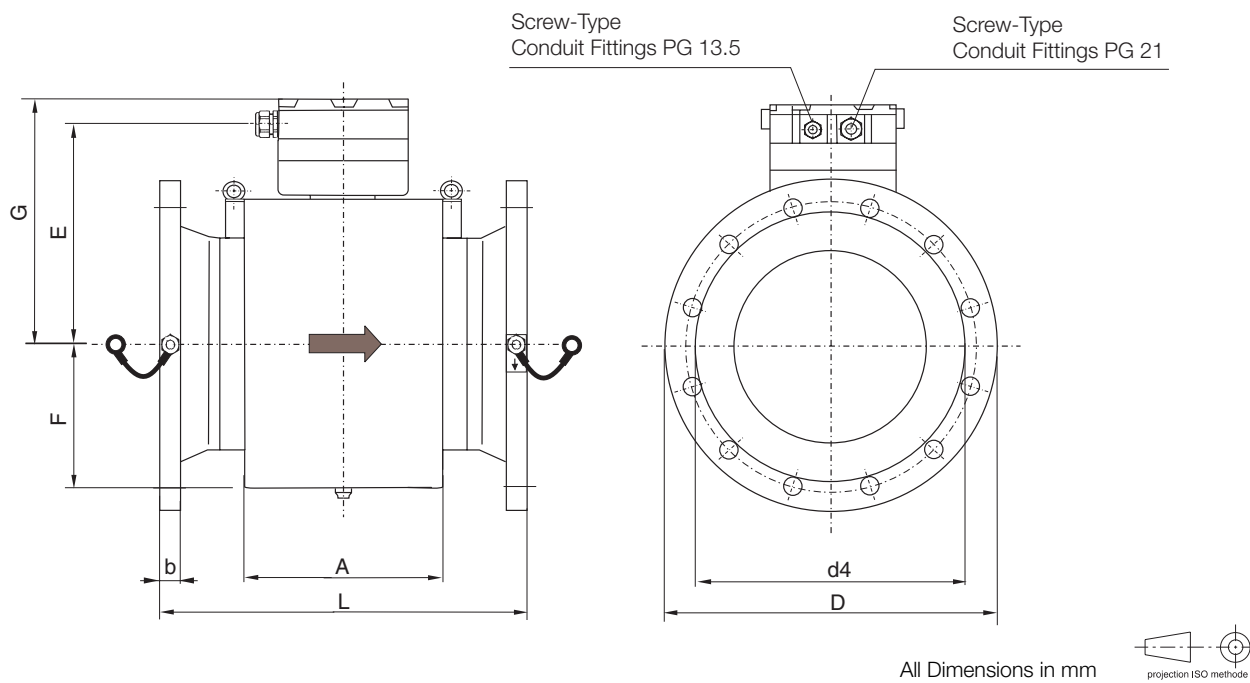

Flange Dimensions					Instrument Dimensions						Weight approx. kg	
DN	PN	D	d4	b	A	L	Protection Flange without ²⁾	with ³⁾	G	E		F
300	10	445	370	31	279	500	Upon request		362	329	224	112
300	16	465	378	33	279	500			362	329	224	117
350	10	505	430	31	300	550			387	354	249	153
350	16	520	438	35	300	550			387	354	249	162
400	10	565	482	31	333	600			412	380	275	166
400	16	580	490	37	333	600			412	380	275	173
500	10	670	585	33	407	650			448	415	311	232
500	16	715	610	39	407	650			448	415	311	277
600	10	780	685	33	469	780			500	466	361	283
600	16	840	725	41	469	780			500	466	361	313
700	10	895	800	35	537	910			543	510	405	394
700	16	910	795	41	537	910			543	510	405	408
800	10	1015	905	37	605	1040			593	560	455	441
800	16	1025	900	43	605	1040			593	560	455	458
900	10	1115	1005	39	671	1170			643	610	505	757
900	16	1125	1000	45	671	1170			643	610	505	772
1000	6	1175	1080	31	739	1300		693	660	555	907	
1000	10	1230	1110	39	739	1300		693	660	555	960	
1000	16	1255	1115	47	739	1300		693	660	555	1007	

¹⁾ > DN 1000 upon request

²⁾ Grounding plate DN 300 and up upon request. See Note "Grounding" section 9.1 and Footnote Ordering Information Flowmeter Primary

³⁾ Protection flanges for PTFE-Liners provide the ground function, grounding plate not required

Fig. 14 Flowmeter Primary DN 300 to DN 1000, DIN-flanges

Dimensional Drawing Flowmeter Primary, DN 150 to DN 900, ASME-flanges

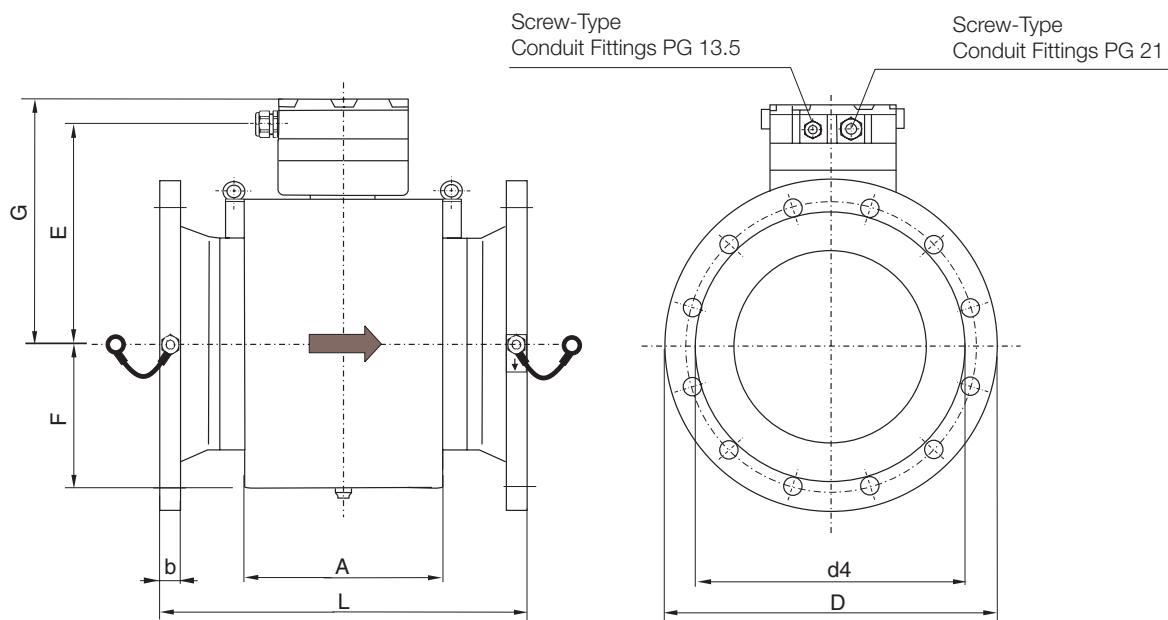

All Dimensions in mm

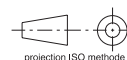

Meter Size		Instrument Dimensions						Flange Dimensions ASME CL 150			Weight approx. kg.
DN	Inch	A	L ^{1) 2)}		E	F	G	D	d4	b	
			ISO 13359	Old inst. length							
150	6	170	300	450	242	139	275	279	216	29	39
200	8	195	350	500	273	179	306	343	270	34	68
250	10	250	450	550	301	207	334	406	324	35	98
300	12	279	500	620	330	224	362	483	381	37	112
350	14	322	550	650	354	249	387	534	413	40	144
400	16	370	600	700	350	275	412	597	470	42	174
500	20	407	762	780	416	311	443	699	584	48	217
600	24	469	914	850	466	361	500	813	692	53	371
700	28	537	–	910	510	405	543	837	762	50	343
800	32	605	–	1040	560	455	593	942	864	51	355
900	36	671	–	1170	610	505	643	1057	972	58	680

¹⁾ If a grounding disk is installed (attached by one side to the flange), the dimension L is increased by 5 mm.

See Note Grounding section 9.1 and Footnote Ordering Information Primary

²⁾ If protective plates are installed (attached on both sides of the flange), the dimension L is increased by 10 mm.

Comments

Drawings < DN 250 upon request

Fig. 15 Flowmeter Primary DN 150 to DN 900, ASME-flanges

Installation Requirements and Grounding Flowmeter Primary

Electrode Axis

The electromagnetic flowmeter for metering in partially full pipelines is to be installed axisymmetrically so that the upper electrode pair is exactly horizontal. An ideal installation with horizontal electrodes is shown in Fig. 16.

A level has been installed in the customer connection box on the flowmeter primary. It is an additional aid in assuring that the flowmeter primary is correctly leveled.

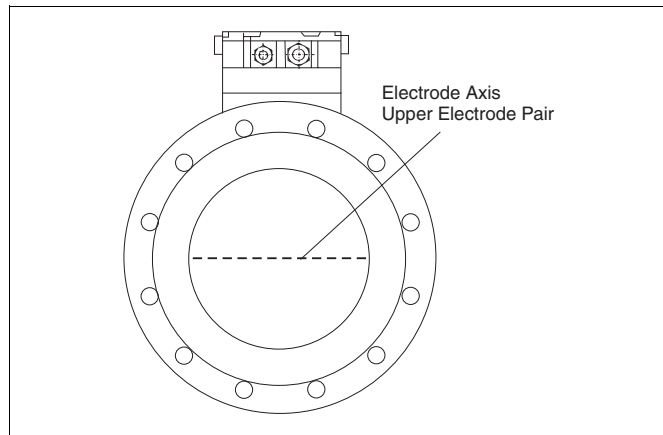

Fig. 16 Electrode Axis

In- and Outlet Sections

The flow profile within the meter must be axisymmetric when the pipe is full. The flow stream must be free of swirl and pulsations. No standing eddies should exist within the meter, such as may occur after elbows or tangential entries.

A hydraulic jump is to be avoided in the metering section. The max. allowable pipeline slope is 5 %. Slope changes within the in- and outlet sections are to be avoided. The optimal gradient lies in a range between 0.8 to 1.5 %.

Note

The following installation requirements are to be observed: A straight section with the same diameter as the flowmeter and a length of at least 5 times the diameter is to be installed upstream and one 3 times the diameter downstream (Fig. 17). Sharp edges in the vicinity of the flowmeter are to be avoided. No additional inlets or outlets are to exist in the inlet section.

For cleaning and examination purposes a inspection opening is recommended (see Fig. 17).

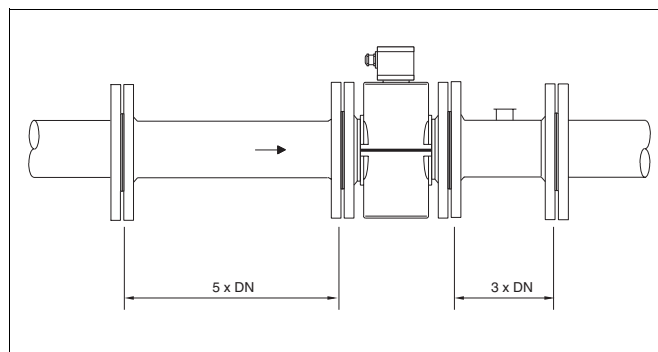

Fig. 17 In- and Outlet Sections

Pipeline Transitions

Transitions from other pipeline sizes or geometries should be made so that the in- and outlet section requirements mentioned previously are maintained. Steps in the bottom of the pipeline are to be avoided.

Grounding

For satisfactory operation of an electromagnetic flowmeter grounding is essential. The ground screws on the flowmeter primary are to be connected to the protection ground in accordance with VDE 0100, Part 540. For technical reasons this potential should be identical to that of the fluid.

For plastic pipes or pipes with electrically insulating liners the ground connection is made using grounding rings or ground electrodes. **Flowmeters with hard or soft rubber liners include in the flange area a conductive element for grounding. Therefore additional grounding rings or grounding electrodes are not required** (see Note: Ordering Information Page 11). When stray currents are present in the fluid and a PTFE or PFA Teflon lined flowmeter primary is installed grounding rings or grounding electrodes at the in- and outlet ends of the meter are recommended.

With model DP46 (Ex-design), grounding terminals and primary flanges have to be connected to Potential Equalization.

Sizing Information

For selecting the optimum meter size a sizing program is available on a 3 1/2" disc. All required calculation values are integrated in the program.

It is recommended that a plan of the installation site be provided to ABB Automation Products during the planning phase for evaluation.

Electromagnetic Flowmeter FXP4000 (PARTI-MAG II)

for Full and Partially Full Pipelines (Free and Surface Pipelines) Model DP41F and DP46F

D184S024U02

Ordering information: Flowmeter Primary, Model DP41F and DP46F

In addition to the Ordering Number please supply the following information: Fluid, fluid temperature, operating pressure, pipeline type, (grounding ring, grounding electrode). Installation sketch with slopes.

Standard-design	DP41F																			
Ex-design	DP46F																			
Liner material																				
Hard rubber	H																			
Soft rubber	S																			
PTFE (up to DN 600)	T																			
Meter size																				
DN 150	1F																			
DN 200	2H																			
DN 250	2F																			
DN 300	3H																			
DN 350	3F																			
DN 400	4H																			
DN 500	5H																			
DN 600	6H																			
DN 700	7H																			
DN 800	8H																			
DN 900	9H																			
DN 1000	1T																			
DN 1200	12																			
DN 1400	14																			
DN 1600	16																			
DN 1800	18																			
DN 2000	2T																			
Measuring electrodes¹⁾																				
SST 1.4571 (316 TI)	S																			
Hastelloy B-3 (upon request)	B																			
Hastelloy C-4 (upon request)	H																			
Titanium	M																			
Tantalum	T																			
Platinum-Iridium	P																			
Others	Z																			
Pressure rating																				
DIN PN 10	C																			
DIN PN 16	D																			
DIN PN 25	E																			
DIN PN 40	F																			
ANSI CL 150 ISO laid length	R																			
ANSI CL 300 ISO laid length	S																			
Flange material																				
Steel	1																			
SST 1.4571	3																			
Others	9																			
Flange accessories																				
Without	A																			
Protection flange 1.4571 (both sides)	B																			
Grounding ring 1.4571 (fastened on one side)	C																			
Others	Z																			
Temperature range																				
Standard design (max. 80 °C)	S																			

Continuation next page

1) Grounding electrodes for hard rubber and soft rubber are Standard.
With PTFE liner a grounding ring is required in case of plastic pipeline.

Please complete details for ordering: Remote signal converter 50XP2000

Electromagnetic Flowmeter FXP4000 (PARTI-MAG II)

for Full and Partially Full Pipelines (Free and Surface Pipelines) Model DP41F and DP46F

D184S024U02

Continue Ordering information: Flowmeter Primary, Model DP41F and DP46F

Standard-design	DP41F																																						
Ex-design	DP46F																																						
Certificates																																							
PED Standard																			A																				
Material certificate per EN 10204 3.1 + pressure test per AD 2000																			D																				
Pressure test per AD 2000																			G																				
Inspection certificate per EN 10204 3.1																			F																				
Type of protection																																							
IP 67																			2																				
IP 68 Thread for screw-type conduit fitting M20 x 1.5																			7																				
IP 68 Cable connected and connection box potted ¹⁾																			8																				
Name plate																																							
German																			G																				
English																			E																				
Design level (specified by ABB)																																							
* * * * *																																							
Additional Options																																							
Without																			A																				
Cable glands 3/4 in. NPT																			N																				
Electrode Design																																							
Round head																			7																				
Laid Length																																							
Short, acc. to ISO 13359																			A																				
Excitation Frequency																																							
6,25 Hz																																						1	
7,50 Hz																																							3

¹⁾ Sealing compound (optional) 5 pieces, part no. D141B038U01

Technical Data Converter 50XP2000



Fig. 18 Converter Field Mount Housing and 19"-Rack Mount Housing

Flow Range

Continuous, 0.5 m/s to 10 m/s

Conductivity

≥ 50 μS/cm

Response Time

0 - 99 % Step function (equiv. to 5τ) >10 s

Damping

Settings to 200 s

Supply Power

115/230 V AC ±10 %
 24 V AC ±10 %
 50/60 Hz ±6 %
 Ripple < 1.5 Vp

Magnetic Field Excitation

6 1/4 Hz, 7 1/2 Hz (50/60 Hz Power supply)

Power Consumption

DN 150 to DN 2000 (6 ... 80")
 < 60 VA (primary including converter)

Ambient Temperature

-20 ... 50 °C (-4 ... 122 °F)

Protection Class per EN 60529

IP 65 for field mount housing
 IP 00 for 19" rack mount design

Design

Stainless steel wall mount housing
 19"-Insert, 167 mm deep, 28 TE, 3 HE

Electrical Connections

Screw terminals
 5 x Cable connectors Pg 13.5
 1 x Cable connector Pg 16/21 for signal cable

Weight

Field mount housing approx. 9.3 kg
 19"-Insert cassette approx. 2.8 kg

Signal Cable/Excitation Cable

The max. cable length between the flowmeter primary and the converter is 50 m. Signal and excitation cable are preassembled and connected to the converter prior to shipment (field mount housing). Ordering Number see Page 16.

Display

2 x 16 character dot-matrix display in Super-twisted technology with LED background lighting. The flow direction is indicated in the 1st line and the instantaneous flowrate in % of the selected flow range or in engineering units. In the 2nd line the value of the integrated flow is displayed in engineering units. Separate totalizer values for each flow direction, 7 digit plus overflow counter.

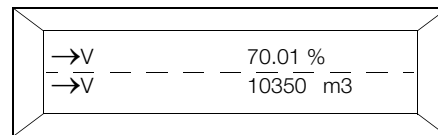

Parameter Settings

Entry is made from the keypad, menu controlled in clear text dialog. All parameter settings, including totalizer values are stored for a 10 year period in EEPROMs. The meter location parameters can be uploaded by pressing a button after a converter exchange.

Forward/Reverse Metering

The direction is indicated in the display by arrows and over a contact output, optocoupler design, for an external alarm.

Input Signals

External Zero Return

Passive or active over operating contact (closer).
 When the pipeline empties all output signals can be turned off.

External Totalizer Reset

Passive or active over operating contact (closer).
 The internal totalizer values can be reset.
 Optocoupler: 16 V ≤ U_{CE} ≤ 30 V DC, R_i = 2000 Ohm.

Output Signals

Isolation In/Output

All in- and outputs are isolated from the signal circuit and each other.

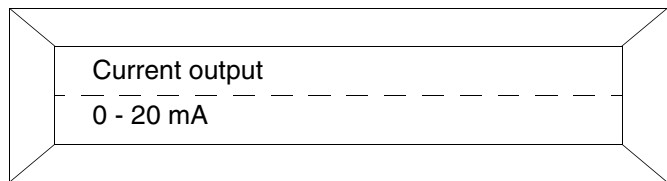

Current Output

0/4-20 mA, load < 1000 Ω
 0/2-10 mA, load < 2000 Ω
 Can be switched by the software

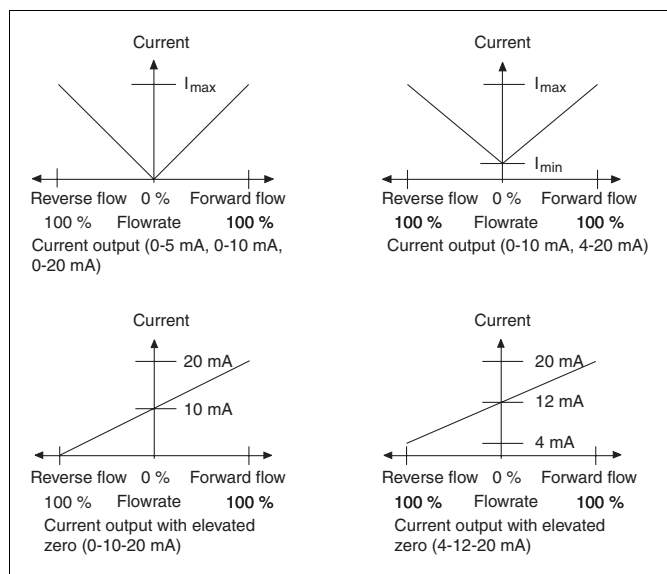

Scaled Pulse Output

Scaled pulse output, separate for each flow direction, max. count frequency 5 kHz. The pulse factor can be set between 0.001 and 1000. Pulse width can be set between 0.1 and 2000 ms.

Active

Voltage pulses 24 V rectangular, load > 150 Ω.

Option

Passive, optocoupler:
 5 V < U_{CE} < 30 V DC
 2 mA < I_{CE} < 220 mA, f_{max} 5 kHz

Contact Output for System Monitoring

During an error condition the internal system monitor displays a clear text error message and activates a contact output.
 Select optocoupler or relay (opens for alarm).
 Errors encountered are stored in an error register.

Optocoupler: 16 V < U_{CEH} < 30 V; 0 V < U_{CEL} < 3.5 V
 0 mA < I_{CEH} < 0.2 mA; 2 mA < I_{CEL} < 15 mA
 Relay: max. 3 W, max. 250 mA, max. 30 V DC

Configurable Contact Outputs

The following functions can be software selected for the contact outputs:

- No function,
- Empty pipe,
- Forward/reverse flow direction signal
- Max. alarm or min. alarm for flowrate
- Optocoupler: 16 V < U_{CEH} < 30 V; 0 V < U_{CEL} < 3.5 V
 0 mA < I_{CEH} < 0.2 mA; 2 mA < I_{CEL} < 15 mA

Serial Interface

The serial interface is available in Rs 485 configuration.

RS 485

V_{pp} = 5 V, input impedance: ≥ 12 kΩ,
 max. cable length ≤ 1200 m.
 Baudrate 1200-9600 Baud.
 Max. 32 instruments in parallel on a single bus. A shielded data cable with individually twisted pairs is recommended.
 Terminals: V1, V2, V3, V4; Function T-, T+, R-, R+.

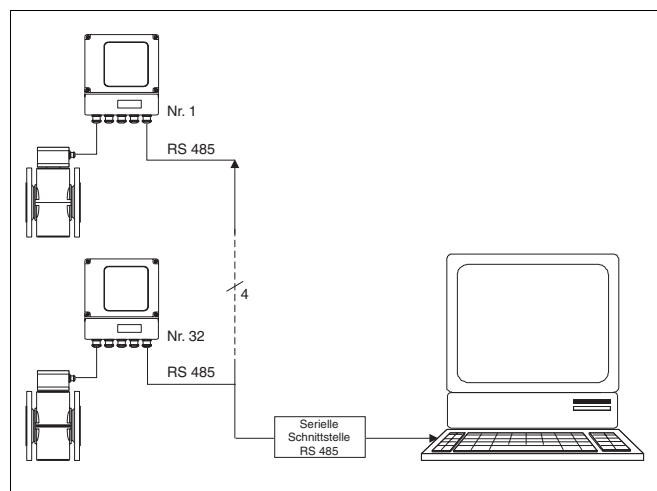

Fig. 19 Communication with RS 485 interface

Communication via Modem

If the converter is equipped with a serial data link it can be connected to a standard modem (Hayes compatible). All parameters of the converter can be interrogated resp. changed.

Dimensional Drawing Converter, Modell 50XP2000

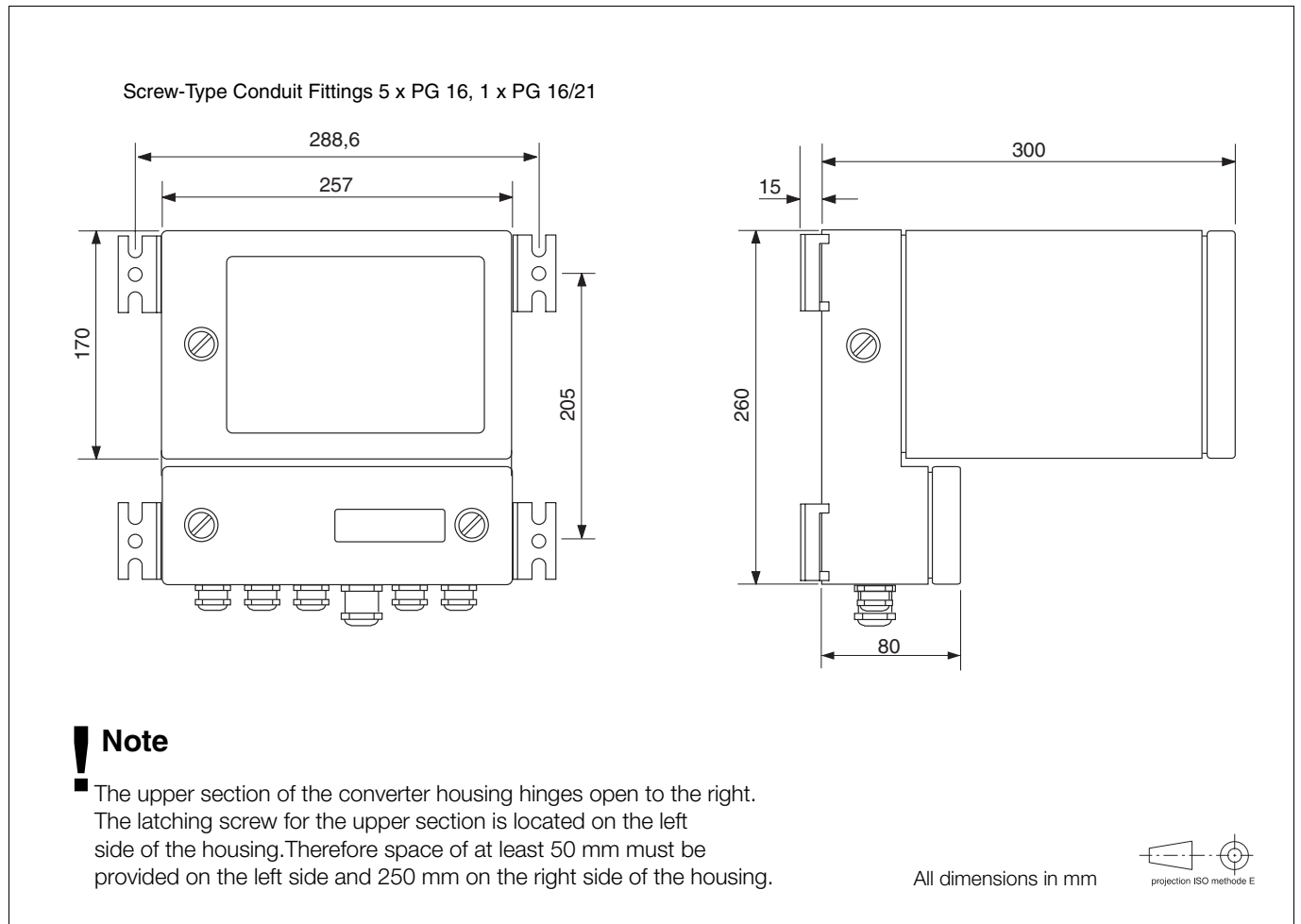

Fig. 20 Field Mount Housing

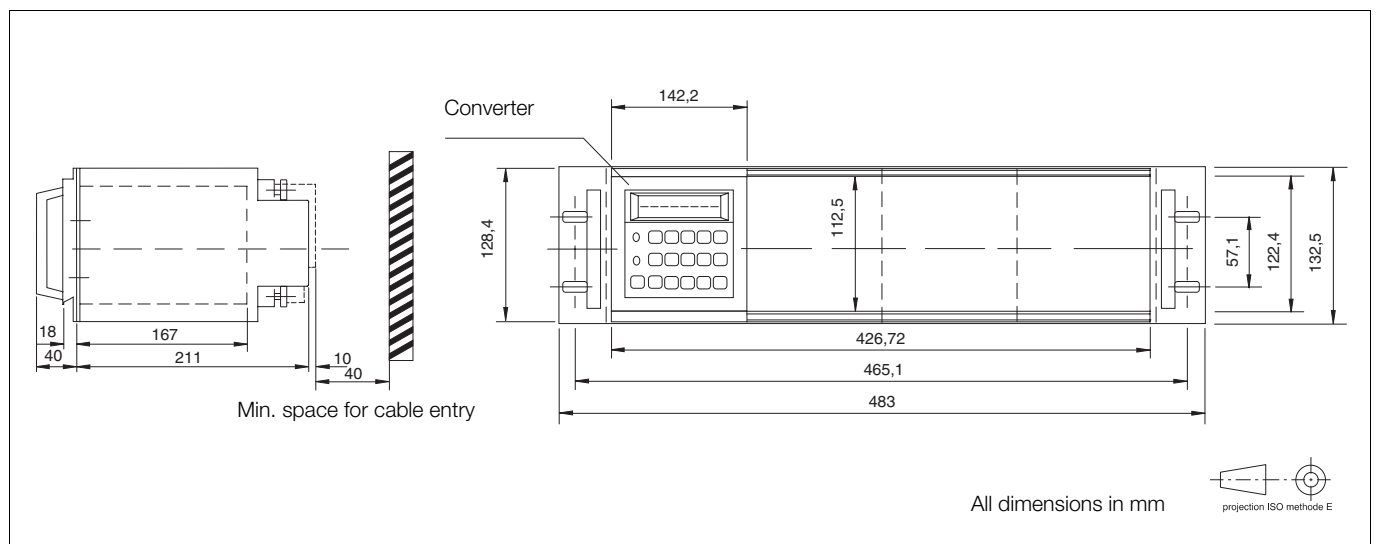
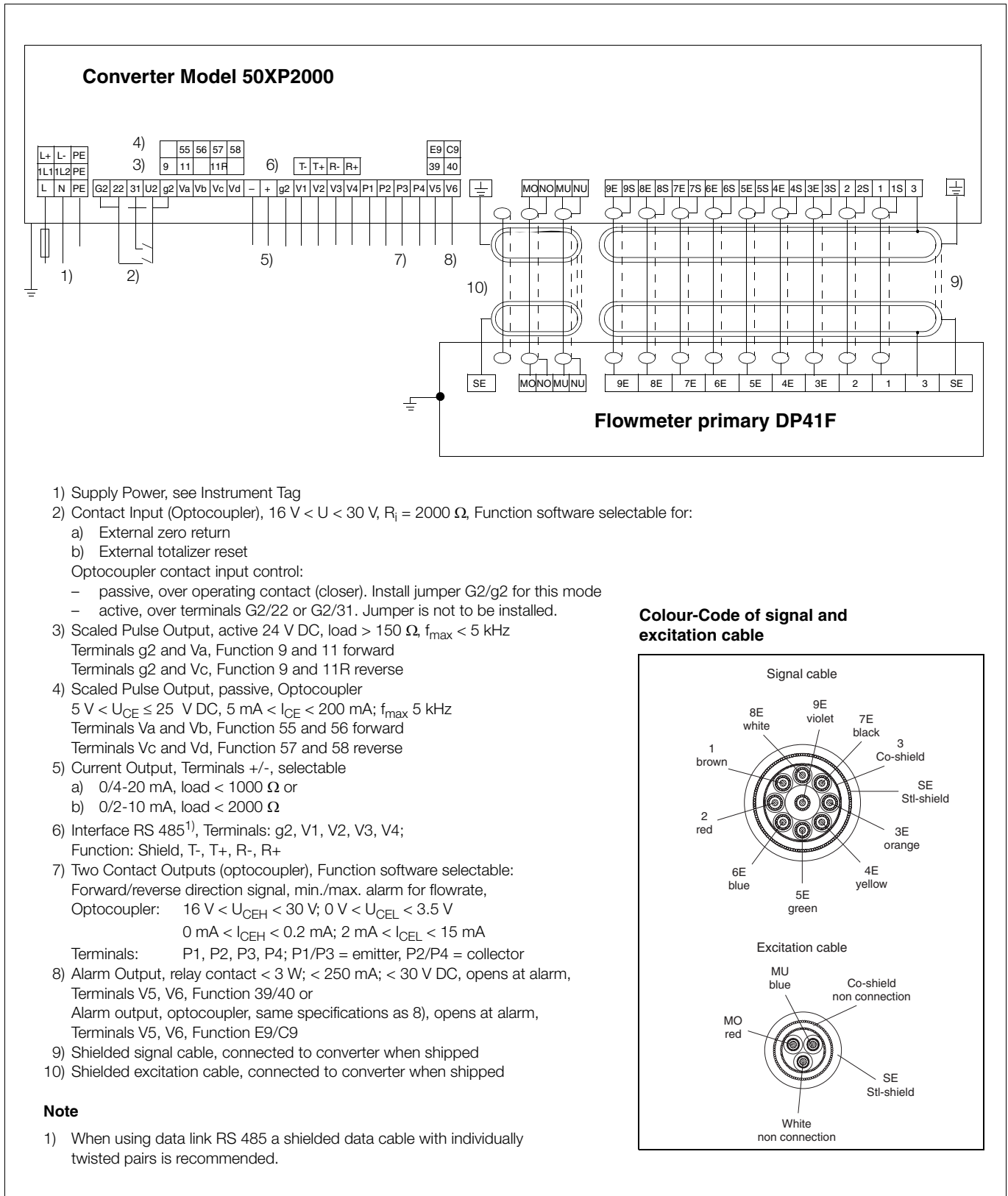

Fig. 21 19" Rack Mount

Interconnection Diagram for standard design, Primary DP41F with converter 50XP2000



Colour-Code of signal and excitation cable

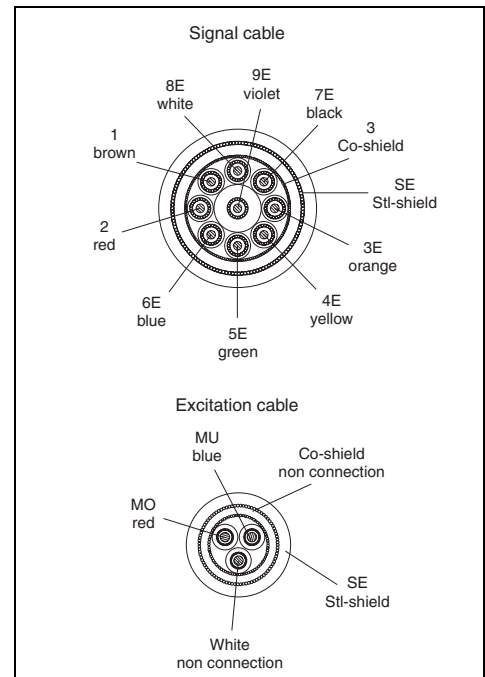

Fig. 22 Converter 50XP2000

Interconnection Diagram for ex-design, Primary DP46F with converter 50XP2000

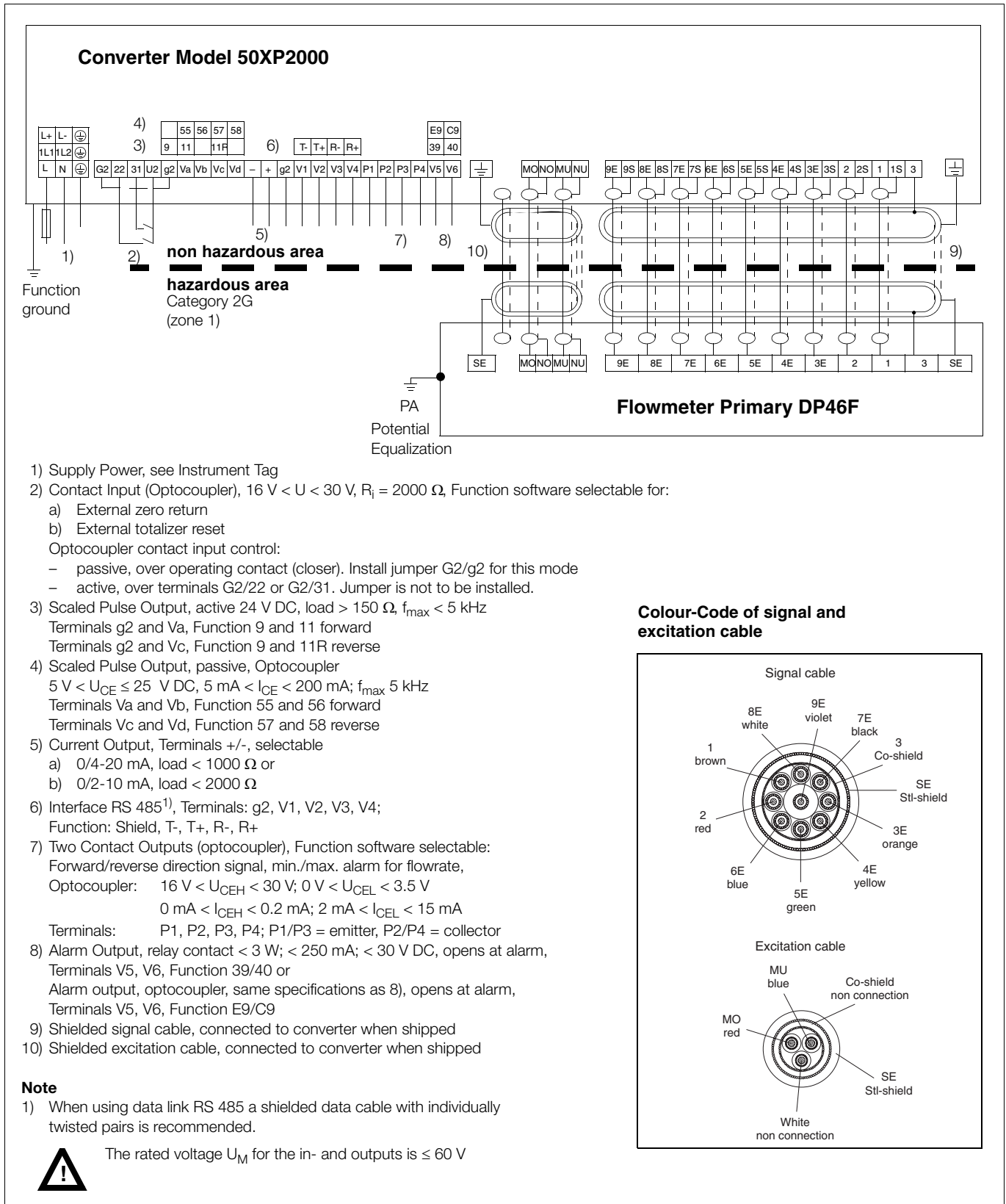

Fig. 23 Converter 50XP2000

Interconnection Examples for Peripherals

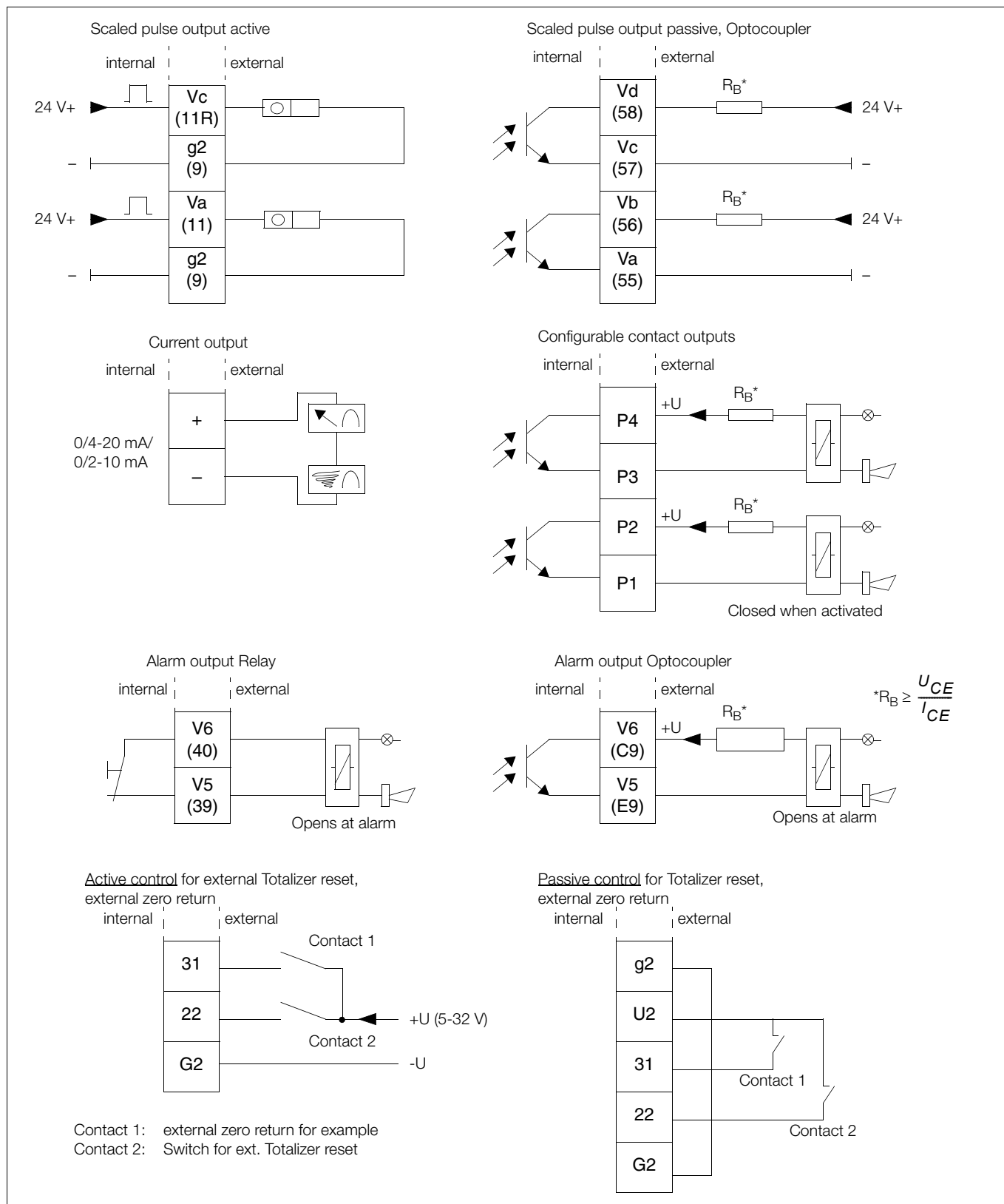

Fig. 24 Interconnection Examples for Peripherals

Contact us

ABB Ltd.

Process Automation

Oldends Lane, Stonehouse
Gloucestershire, GL10 3TA
UK

Phone: +44 (0)1453 826661

Fax: +44 (0)1453 829671

ABB Inc.

Process Automation

125 E. County Line Road
Warminster PA 18974
USA

Phone: +1 215 674 6000

Fax: +1 215 674 7183

ABB Automation Products GmbH

Process Automation

Dransfelder Str. 2
37079 Goettingen
Germany

Phone: +49 551 905-534

Fax: +49 551 905-555

www.abb.com

Note

We reserve the right to make technical changes or modify the contents of this document without prior notice. With regard to purchase orders, the agreed particulars shall prevail. ABB does not accept any responsibility whatsoever for potential errors or possible lack of information in this document.

We reserve all rights in this document and in the subject matter and illustrations contained therein. Any reproduction, disclosure to third parties or utilization of its contents – in whole or in parts – is forbidden without prior written consent of ABB.

Copyright© 2011 ABB

All rights reserved