

# Electrical Linear Actuators LME620 / RSD10 ... 100 (Contract)

Rated force 4 ... 100 kN  
(900 ... 22500 lbf)

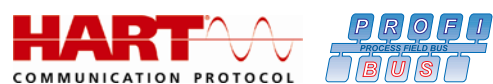

# Electrical Linear Actuators LME620 / RSD10 ... 100 (Contrac)

## Operating Instruction

OI/LME/RSD10\_100-EN

09.2011

Rev. A

Translation of the original instruction

### Manufacturer:

#### **ABB Automation Products GmbH**

Schillerstraße 72

32425 Minden

Germany

Tel.: +49 551 905-534

Fax: +49 551 905-555

#### **Customer service center**

Phone: +49 180 5 222 580

Fax: +49 621 381 931-29031

[automation.service@de.abb.com](mailto:automation.service@de.abb.com)

© Copyright 2011 by ABB Automation Products GmbH

Subject to changes without notice

This document is protected by copyright. It assists the user in safe and efficient operation of the device. The contents of this document, whether whole or in part, may not be copied or reproduced without prior approval by the copyright holder.

<b>1</b>	<b>Safety</b> .....	<b>5</b>
1.1	General information and notes for the reader .....	5
1.2	Intended use.....	5
1.3	Target groups and qualifications .....	5
1.4	Warranty provisions.....	5
1.5	Plates and symbols .....	6
1.5.1	Safety-/ warning symbols, note symbols.....	6
1.5.2	Name plate .....	7
1.6	Transport safety information.....	9
1.7	Storage conditions.....	9
1.8	Installation safety information.....	10
1.9	Safety information for electrical installation.....	10
1.10	Operating safety information .....	11
1.11	Maintenance safety information .....	11
1.12	Safety instructions related to the raw materials and supplies .....	12
1.13	Returning devices.....	12
1.14	Integrated management system.....	13
1.15	Disposal.....	13
1.15.1	Information on WEEE Directive 2002/96/EC (Waste Electrical and Electronic Equipment).....	13
1.15.2	RoHS Directive 2002/95/EC .....	13
<b>2</b>	<b>Design and function</b> .....	<b>14</b>
<b>3</b>	<b>Mounting</b> .....	<b>16</b>
3.1	Actuator check.....	16
3.2	Installation instructions .....	16
3.2.1	Valve requirements .....	16
3.3	Installation position .....	17
3.3.1	LME620.....	17
3.3.2	RSD10 ... 100 .....	17
3.4	Mounting examples .....	18
3.5	Adaptation of actuator stroke to the valve stroke (RSD, only) .....	19
3.6	Assembly with the valve .....	20
<b>4</b>	<b>Electrical connections</b> .....	<b>20</b>
<b>5</b>	<b>Operation</b> .....	<b>21</b>
5.1	Manual operation.....	22
5.2	Handwheel operation in combination with positioning time-out function .....	22
<b>6</b>	<b>Maintenance</b> .....	<b>23</b>
6.1	Inspection and overhaul .....	23
6.2	Removing the motor and adjusting the brakes.....	24
6.3	Oil change (RSD, only).....	24
6.3.1	Filling capacity.....	25
6.4	Grease lubrication (LME, only).....	25
<b>7</b>	<b>Trouble shooting</b> .....	<b>26</b>
7.1	Electrical test values.....	26
<b>8</b>	<b>Specifications</b> .....	<b>27</b>
8.1	LME620 .....	27
8.2	RSD10 ... 100 .....	28
<b>9</b>	<b>Appendix</b> .....	<b>30</b>

## Contents

---

9.1	Other applicable documents.....	30
9.2	Approvals and certifications .....	30
<b>10</b>	<b>Index .....</b>	<b>33</b>

## 1 Safety

### 1.1 General information and notes for the reader

You must read these instructions carefully prior to installing and commissioning the device.

These instructions are an important part of the product and must be kept for future reference.

These instructions are intended as an overview and do not contain detailed information on all designs for this product or every possible aspect of installation, operation and maintenance.

For additional information or if specific problems occur that are not discussed in these instructions, contact the manufacturer.

The content of these instructions is neither part of any previous or existing agreement, promise or legal relationship nor is it intended to change the same.

This product is built based on state-of-the-art technology and is operationally safe. It has been tested and left the factory in perfect working order from a safety perspective. The information in the manual must be observed and followed in order to maintain this state throughout the period of operation.

Modifications and repairs to the product may only be performed if expressly permitted by these instructions.

Only by observing all of the safety instructions and all safety/warning symbols in these instructions can optimum protection of both personnel and the environment, as well as safe and fault-free operation of the device, be ensured.

Information and symbols directly on the product must be observed. They may not be removed and must be fully legible at all times.

### 1.2 Intended use

The actuators are used for operating final control elements (valves, vanes, etc.). They may only be operated using the appropriate Contrac electronic unit. Do not use these actuators for any other purpose. Otherwise, a hazard of personal injury or of damage to or impairment of the operational reliability of the device may arise. In addition to these operating instructions, the relevant documentation for the electronic unit and software tools must be observed.

### 1.3 Target groups and qualifications

Installation, commissioning, and maintenance of the product may only be performed by trained specialist personnel who have been authorized by the plant operator accordingly. The specialist personnel must have read and understood the manual and must comply with its instructions.

The operating company must strictly observe the applicable national regulations relating to the installation, function testing, repair, and maintenance of electrical products.

### 1.4 Warranty provisions

Using the device in a manner that does not fall within the scope of its intended use, disregarding this instruction, using underqualified personnel, or making unauthorized alterations releases the manufacturer from liability for any resulting damage. This renders the manufacturer's warranty null and void.

## 1.5 Plates and symbols

### 1.5.1 Safety-/ warning symbols, note symbols

**DANGER – <Serious damage to health / risk to life>**

This symbol in conjunction with the signal word "Danger" indicates an imminent danger. Failure to observe this safety information will result in death or severe injury.

**DANGER – <Serious damage to health / risk to life>**

This symbol in conjunction with the signal word "Danger" indicates an imminent electrical hazard. Failure to observe this safety information will result in death or severe injury.

**WARNING – <Bodily injury>**

This symbol in conjunction with the signal word "Warning" indicates a possibly dangerous situation. Failure to observe this safety information may result in death or severe injury.

**WARNING – <Bodily injury>**

This symbol in conjunction with the signal word "Warning" indicates a potential electrical hazard. Failure to observe this safety information may result in death or severe injury.

**CAUTION – <Minor injury>**

This symbol in conjunction with the signal word "Caution" indicates a possibly dangerous situation. Failure to observe this safety information may result in minor or moderate injury. This may also be used for property damage warnings.

**NOTICE – <Property damage>!**



The symbol indicates a potentially damaging situation.

Failure to observe this safety information may result in damage to or destruction of the product and/or other system components.

**IMPORTANT (NOTE)**

This symbol indicates operator tips, particularly useful information, or important information about the product or its further uses. It does not indicate a dangerous or damaging situation.

**1.5.2 Name plate**

1	Antrieb / Actuator: CONTRAC ....		
2	F-Nr./No	NL	
3	F =	Jahr/Year	CE
4	t =	IP 66, NEMA 4X	
5	s = min. .... max. ....	V = ..... mm/s	
6	Fett / Grease		
7	Elektronik/Electronics		
8	U = 230 V (190 ... 260 V) F = 50/60 Hz, ± 5 %		
9	P = max. .... W Ext. Sicherung / Fuse 16 A träge/slow		
10			
ABB Automation			
D-32425 Minden			
Made in Germany			

M00452

Fig. 1: LME name plate

- |  |   |
|--|---|
| 1 Full name of model   | 6 Filled oil types  |
| 2 Serial no. / NL no. (no. of non-list version)                | 7 Associated Contrac electronic unit  |
| 3 Output force / Year of manufacture                           | 8 Permissible voltage range / mains frequency (for LME620-AI only)            |
| 4 Permissible ambient temperature / protection class / CE mark | 9 Power consumption / specifications for fuse protection (for LME620-AI only) |
| 5 Min., max. stroke / max. actuating speed / heater (option)   | 10 Blank for customer-specific entry  |

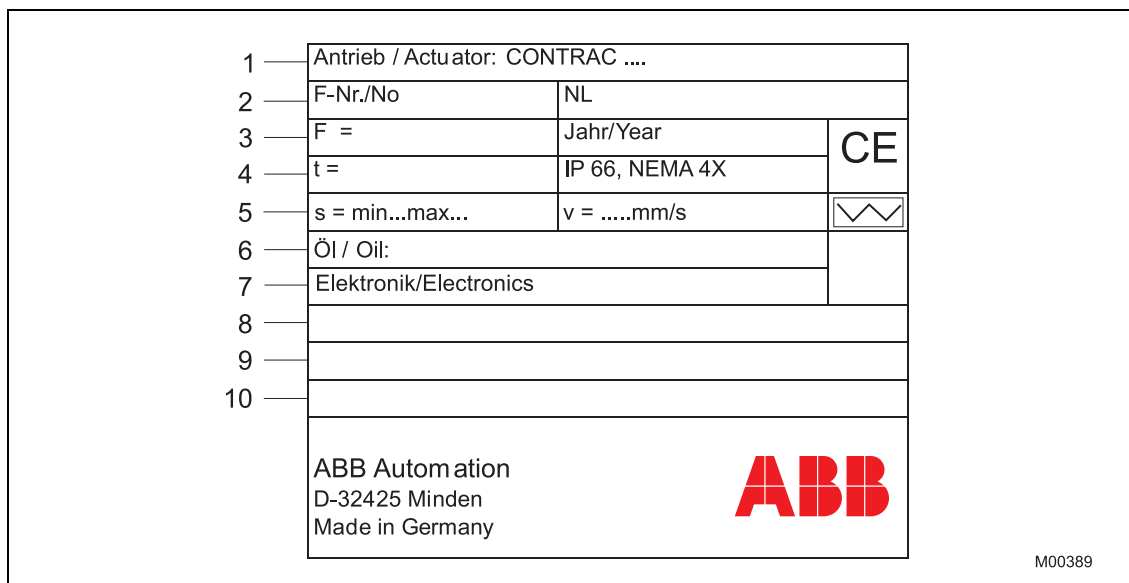

Fig. 2: Name plate RSD

- |  |                                      |
|--|--------------------------------------|
| 1 Full name of model   | 6 Filled oil types                   |
| 2 Serial no. / NL no. (no. of non-list version)              | 7 Associated Contrac electronic unit |
| 3 Output force / Year of manufacture                         | 8 Blank                              |
| 4 Permissible ambient temperature / protection class/CE mark | 9 Blank                              |
| 5 Min., max. stroke / max. actuating speed / heater (option) | 10 Blank for customer-specific entry |

## 1.6 Transport safety information



### **WARNING - Falling or toppling loads!**

Risk of death or serious injury due to the device falling down or toppling over!

- Do not stand under suspended loads!
- Do not detach the hoisting equipment until installation is complete!
- Only use the dedicated load pick-up devices (eyebolts) for suspending the components!

Check the devices for possible damage that may have occurred during transport. Damages in transit must be recorded on the transport documents. All claims for damages must be claimed without delay against the shipper and before the installation.

Ensure that the specified environmental conditions in the Technical Data chapter are complied with.

## 1.7 Storage conditions



### **IMPORTANT (NOTE)**

The storage data provided below assumes that the devices are fully closed and thus comply with the degree of protection stated in the technical specifications. When devices are supplied, their degree of protection is guaranteed. If they have been subsequently tested or commissioned, the degree of protection must be ensured again before they are put into storage.

The devices may be stored under moist and corrosive conditions for a short time. The equipment is protected against external corrosive influences. However, direct exposure to rain, snow, etc., must be avoided.

The permissible storage and transport temperatures must be observed.

Devices equipped with a heater are also protected by desiccant, which is placed in the following locations where condensation may be a problem:

Position sensor:	In connection chamber
Electronic unit:	In electrical connection chamber

The desiccant guarantees sufficient protection for approximately 150 days. It can be regenerated at a temperature of 90 °C (114 °F) within 4 h.

Remove the desiccant prior to commissioning the actuator or the electronic unit.

If you intend to store or transport the device for a long period of time (> 6 months), we recommend that you wrap it in plastic foil and add desiccant.

Protect uncovered metallic surfaces with an appropriate long-term corrosion inhibitor.

The relevant long-term storage temperatures must be observed.

## 1.8 Installation safety information



### **WARNING - Falling or toppling loads!**

Risk of death or serious injury due to the device falling down or toppling over!

- Do not stand under suspended loads!
  - Do not detach the hoisting equipment until installation is complete!
  - Only use the dedicated load pick-up devices (eyebolts) for suspending the components!
- 
- Only qualified specialists who have been trained for these tasks are authorized to mount and adjust the control actuator, and to make the electrical connection.
  - When working on the actuator itself or the electronics always observe the locally valid accident prevention regulations and the regulations concerning the construction of technical installations.
  - Make sure that no process forces are exerted on the control element.
  - Do not use the motor or handwheel to lift the actuator.
  - The load pick-up device on the actuator (eyebolt) must only be loaded in a vertical direction. Only use the load pick-up device for lifting/lowering the actuator (without final control element mounted).

## 1.9 Safety information for electrical installation

- The electrical connection may only be made by authorized specialist personnel and in accordance with the electrical circuit diagrams.
- The electrical connection information in the manual of the electronic unit must be observed; otherwise, the type of electrical protection may be adversely affected.
- Safe isolation of electrical circuits which are dangerous if touched is only guaranteed if the connected devices satisfy the requirements of DIN EN 61140 (VDE 0140 Part 1) (basic requirements for safe isolation).
- To ensure safe isolation, install supply lines so that they are separate from electrical circuits which are dangerous if touched, or implement additional isolation measures for them.



### **IMPORTANT (NOTE)**

Refer to the operating instructions of the power electronic unit for the electrical connection diagrams.

### 1.10 Operating safety information

**WARNING - Live components!**

Risk of death or serious injuries due to electricity and unexpected machine movements!  
In automatic mode the motor is always under power, even at standstill!

**WARNING - risk of crushing!**

Danger of injuries due to crushing between external stop and valve yoke / actuator housing!  
Do not reach into the danger zone!

Before switching on, ensure that the specified environmental conditions in the “Technical Data” chapter or data sheet are complied with and that the power supply voltage corresponds with the voltage specified on the name plate of the power electronic unit.

If there is a chance that safe operation is no longer possible, take the unit out of operation and secure against unintended startup.

When mounting the actuator in areas that may be accessed by unauthorized persons, take the required protective measures.

Switch off the power supply to the motor before starting handwheel operation.

### 1.11 Maintenance safety information

**WARNING - risk of injury!**

Note that the actuator position may be changed accidentally by the repelling power of the valve when the brake is released or the motor is removed!  
Make sure that process forces are not exerted on the thrust rod.

- When changing the oil of the actuator, thoroughly remove any oil that may have run down on the floor during the procedure to avoid accidents.
- Dispose of old oil according to local regulations. Make sure that no oil reaches the water cycle.
- Make sure that any oil leaking from the device cannot come into contact with hot parts.
- Switch off the supply voltage for the power electronic unit and, if necessary, disconnect the separately supplied anti-condensation heater (option) when working on the actuator or related subassemblies and take precautions to prevent unintentional switch-on.

### 1.12 Safety instructions related to the raw materials and supplies

#### **Observe the manufacturer's regulations and safety data sheets!**

- Mineral oil and grease can contain additives that, under special conditions, may lead to adverse effects.
- Skin contact with oil or grease may cause skin damage (skin irritations, inflammations, allergies). Avoid long-term, excessive or repeated skin contact. If lubricants contact your skin, immediately wash with water and soap! Do not allow lubricants to get in contact with open wounds!
- If lubricant splashes into the eye, rinse with plenty of water for at least 15 minutes and then consult a doctor!
- When handling lubricants use appropriate skin protection and care products or wear oil-resistant gloves.
- Lubricants that have run down to the floor are a potential source of danger, due to the slip hazard. Spread sawdust or use oil adsorbent to bind and remove the lubricants.

### 1.13 Returning devices

Use the original packaging or suitably secure shipping containers if you need to return the device for repair or recalibration purposes. Fill out the return form (see the Appendix) and include this with the device.

According to EC guidelines for hazardous materials, the owner of hazardous waste is responsible for its disposal or must observe the following regulations for shipping purposes:

All devices delivered to ABB Automation Products GmbH must be free from any hazardous materials (acids, alkalis, solvents, etc.).

Please contact Customer Center Service acc. to page 2 for nearest service location.

### 1.14 Integrated management system

ABB Automation Products GmbH operates an integrated management system, consisting of:

- Quality management system to ISO 9001:2008
- Environmental management system to ISO 14001:2004
- Occupational health and safety management system to BS OHSAS 18001:2007 and
- Data and information protection management system

Environmental awareness is an important part of our company policy.

Our products and solutions are intended to have a minimal impact on the environment and on people during manufacturing, storage, transport, use, and disposal.

This includes the environmentally-friendly use of natural resources. We conduct an open dialog with the public through our publications.

### 1.15 Disposal

This product is manufactured from materials that can be reused by specialist recycling companies.

#### 1.15.1 Information on WEEE Directive 2002/96/EC (Waste Electrical and Electronic Equipment)

This product is not subject to WEEE Directive 2002/96/EC or relevant national laws (e.g., ElektroG in Germany).

The product must be disposed of at a specialist recycling facility. Do not use municipal garbage collection points. According to the WEEE Directive 2002/96/EC, only products used in private applications may be disposed of at municipal garbage facilities. Proper disposal prevents negative effects on people and the environment, and supports the reuse of valuable raw materials.

If it is not possible to dispose of old equipment properly, ABB Service can accept and dispose of returns for a fee.

#### 1.15.2 RoHS Directive 2002/95/EC

With the Electrical and Electronic Equipment Act (ElektroG) in Germany, the European Directives 2002/96/EC (WEEE) and 2002/95/EC (RoHS) are translated into national law. ElektroG defines the products that are subject to regulated collection and disposal or reuse in the event of disposal or at the end of their service life. ElektroG also prohibits the marketing of electrical and electronic equipment that contains certain amounts of lead, cadmium, mercury, hexavalent chromium, polybrominated biphenyls (PBB), and polybrominated diphenyl ethers (PBDE) (also known as hazardous substances with restricted uses).

The products provided by ABB Automation Products GmbH do not fall within the current scope of the directive on waste from electrical and electronic equipment according to ElektroG. If the necessary components are available on the market at the right time, in the future these substances will no longer be used in new product development.

**2 Design and function**

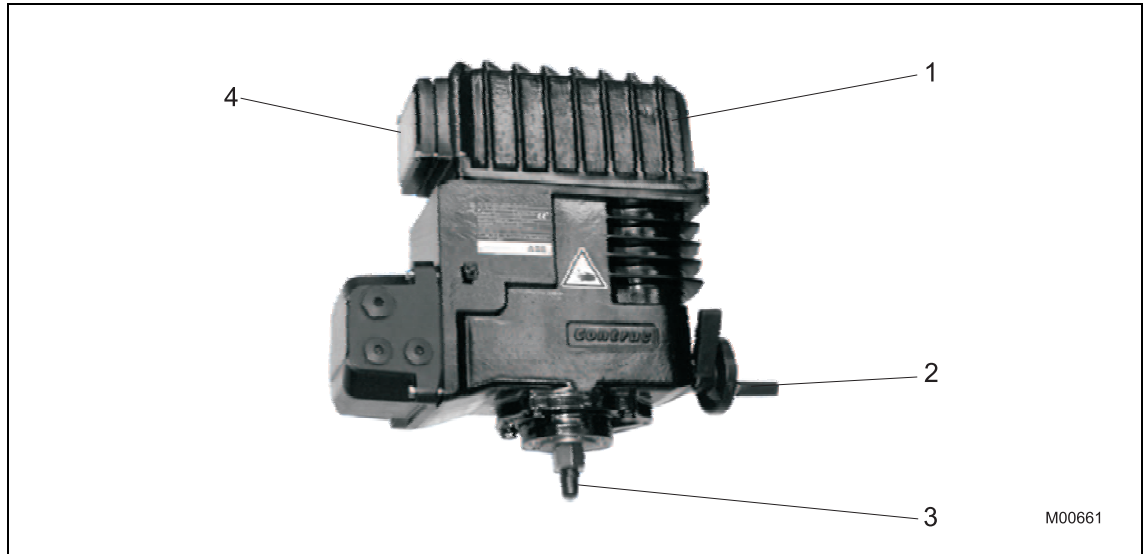

Fig. 3: LME620 (illustrations may differ from actual installation)

- |                           |  |
|---------------------------|--|
| 1 Cover (LME620-AI, only) | 3 Thrust rod   |
| 2 Handwheel               | 4 Commissioning and service field (ISF), (LME620-AI) |

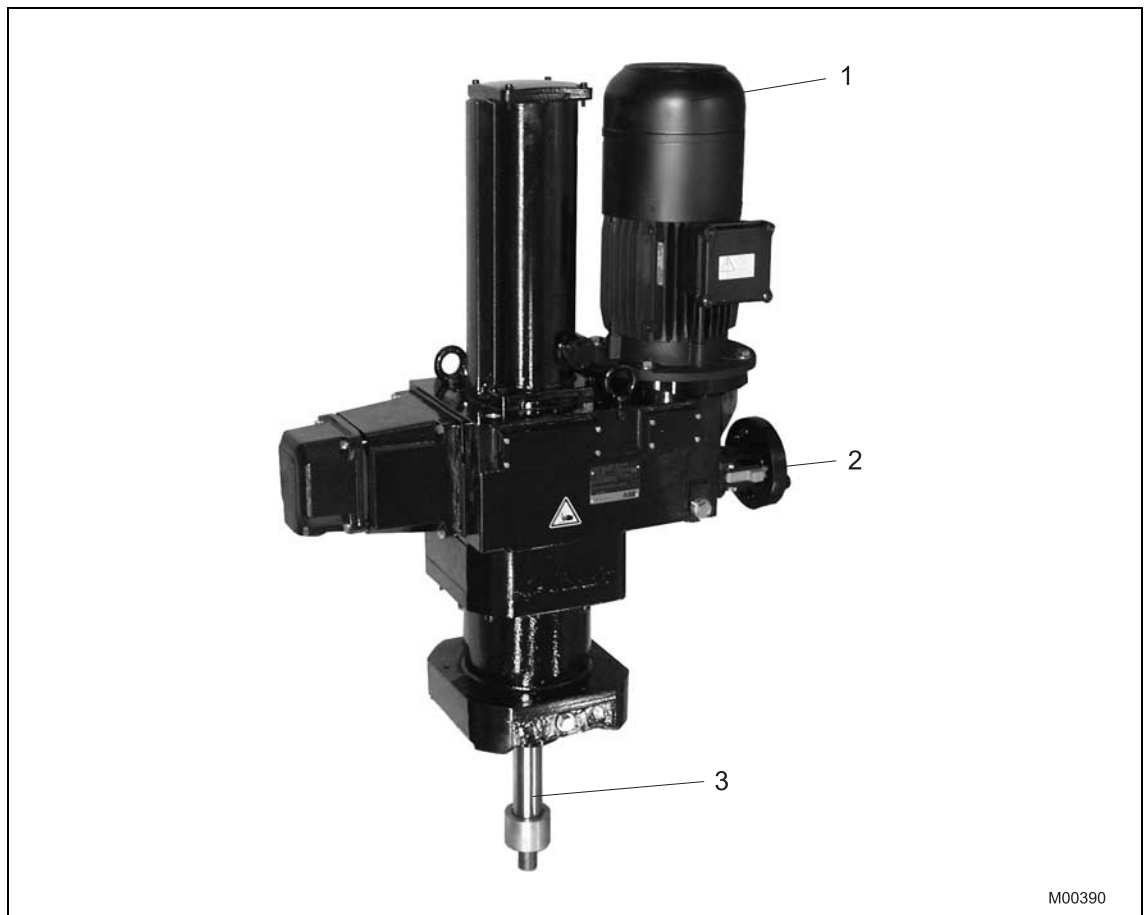

Fig. 4: RSD10 ... 100 (illustrations may differ from actual installation)

- 1 Servo motor
- 2 Handwheel
- 3 Thrust rod

### Functionality

Actuator for the operation of final control elements with preferably linear movement. The actuator thrust rod transfers the force directly to the final control element.

A continuous power electronic unit controls the actuator. The electronic unit serves as the interface between actuator and control system.

During continuous positioning the power electronic unit varies the motor torque steplessly until the actuator force and the restoring process forces are balanced. High response sensitivity and high positioning accuracy with short stroke time ensure excellent control quality and a long actuator life.

### 3 Mounting

**WARNING - Falling or toppling loads!**

Risk of death or serious injury due to the device falling down or toppling over!

- Do not stand under suspended loads!
- Do not detach the hoisting equipment until installation is complete!
- Only use the dedicated load pick-up devices (eyebolts) for suspending the components!

#### 3.1 Actuator check

Before you start to install the actuator make sure that the delivery status corresponds to the ordered status and to the intended use.

- Check the oil level when installing the device in any position other than IMV 1 (refer to Fig. 6 and Fig. 7).
- Fasten the vent valve in the uppermost bore, depending on the actuator's mounting orientation (refer to Fig. 6 and Fig. 7).
- Make sure that the motor and the connection chambers are free of dirt, moisture and corrosion.
- Make sure adequate travel is provided for the valve stroke.

#### 3.2 Installation instructions

- Make sure that the actuator is accessible from all sides to ensure convenient hand wheel operation, electrical connection, and replacement of assemblies.
- Avoid direct exposure to rain, snow and other environmental influences.
- In IMV 1 mounting position, the actuators are resistant against vibrational loading acc. to EN 60068-2-6, table C.2 up to 150 Hz and additionally 1 g / 30 min.
- The maximum rated force of the actuator must not be permanently exceeded. Occasionally and for short periods only, loads of up to twice the rated force are permissible.
- When mounting the actuator close to heat sources use an insulating layer or shielding.

##### 3.2.1 Valve requirements

- The force in the end position can be up to 2.5 times higher than the rated force.

**3.3 Installation position**

**3.3.1 LME620**

The actuator's gearing LME620 is lubricated with grease. This means that any mounting position can be selected.

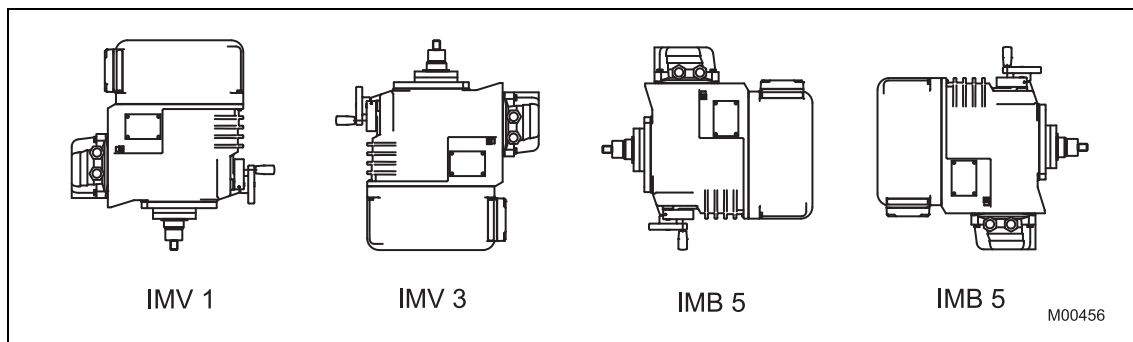

Fig. 5

**3.3.2 RSD10 ... 100**

The gears of the actuator LME620 / RSD10 ... 100 (Contrac) are oil lubricated. They contain the max. oil quantity when leaving the manufacturer. Once the actuator is installed replace the uppermost check plug by the separately supplied venting plug.

All mounting orientations shown in Fig. 6 and fig. Fig. 7 are permissible. To facilitate mounting and maintenance, however, it is recommended to use orientation IMV 1. For each mounting position, check the oil level prior to commissioning.

In order to ensure sufficient ventilation and space for motor de-/installation allow for min. 80 mm (3.15 inch).

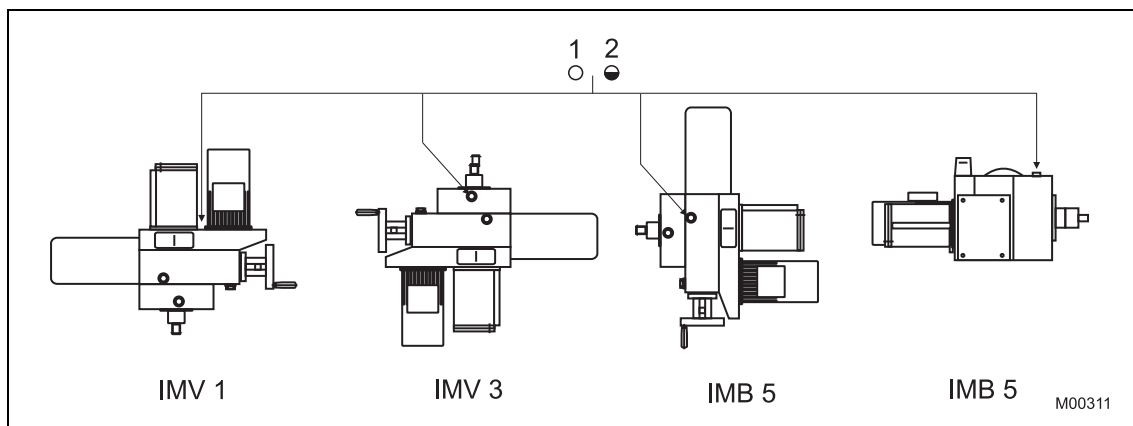

Fig. 6: Mounting orientations RSD10 / RSD20

1 Inspection plug

2 Venting plug

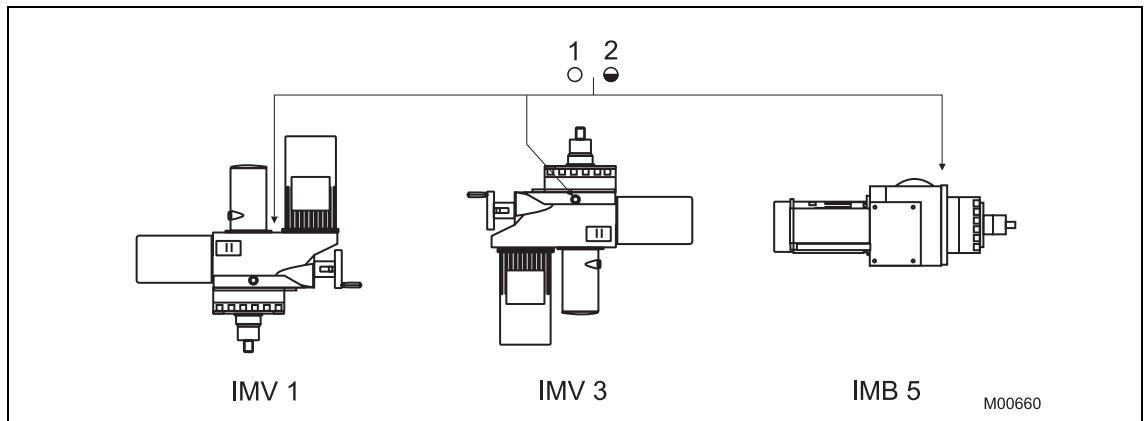

Fig. 7: Mounting orientations RSD50 / RSD100

1 Inspection plug

2 Venting plug

### 3.4 Mounting examples

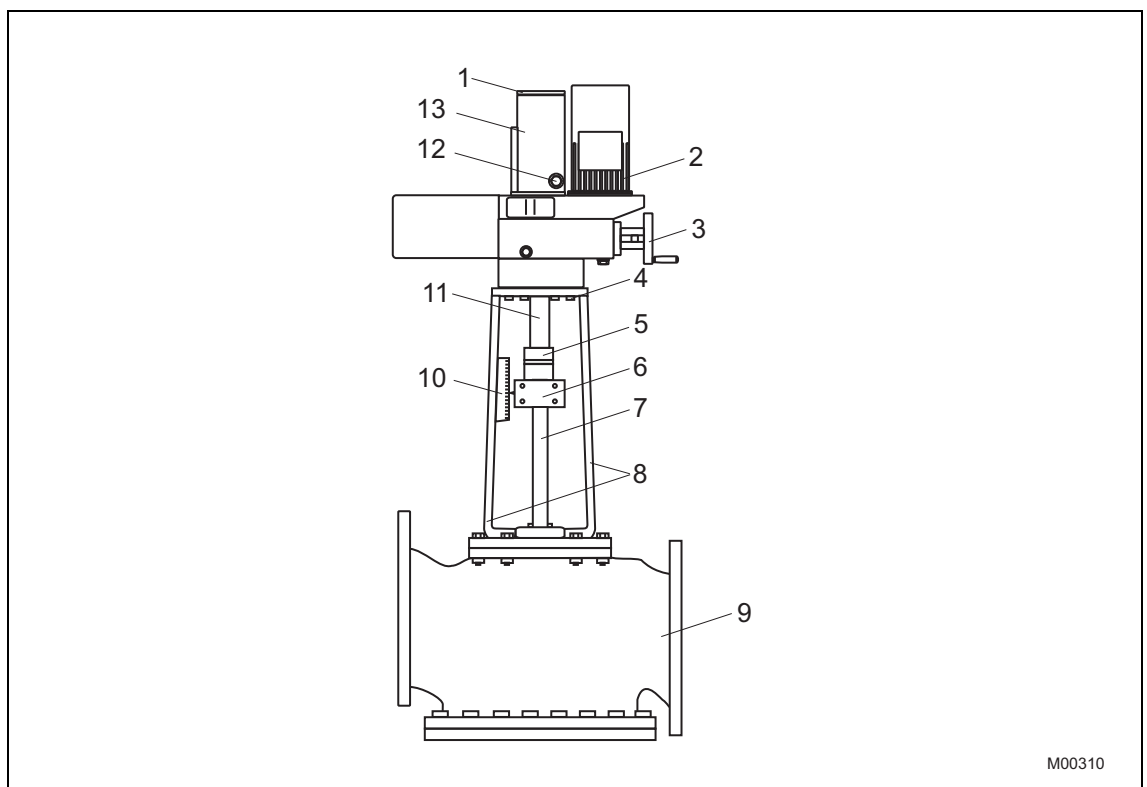

Fig. 8: Mounting examples

1 Lid of thrust rod cover (RSD10 ... 100, only)

2 Servo motor

3 Handwheel

4 Mounting screws (8.8)

5 External stop

6 Coupling

7 Valve stem

8 Valve yoke

9 Valve

10 Mechanical position indicator

11 Thrust rod

12 Screw plug for stop adjustment (RSD10 ... 100, only)

13 Thrust rod cover (RSD10 ... 100, only)

### 3.5 Adaptation of actuator stroke to the valve stroke (RSD, only)

The factory-set actuator stroke corresponds to the stroke named on the ID-label + 1 mm (0,04 inch). If an application requires stroke adjustment, proceed as follows (comply with min./max. stroke; see "Technical Data"):



#### IMPORTANT (NOTE)

With a mounting position other than IMV 1, drain the oil until the oil level is below the thrust rod cover (Fig. 8/13).

1. Manually drive the thrust rod completely out. The internal limit stop should now be touching the driving sleeve.
2. Loosen the screws of the thrust rod cover and remove the cover.
3. Open the screw plug in the thrust rod cover.
4. Both Allen clamping screws are accessible through the opening. Loosen the screws.
5. Use the hand wheel to drive in the thrust rod until the actuator stroke matches the required valve stroke.
6. Turn the internal limit stop (slotted ring nut) clockwise until it is touching the drive sleeve. Finally, turn it back approx. 1 turn.
7. Tighten both Allen screws to the required torque.

RSD10 / RSD20:	26 Nm (19.18 lbf-ft)
RSD50:	26 Nm (19.18 lbf-ft)
RSD100:	40 Nm (29.5 lbf-ft)
8. Reattach the cover for the thrust rod.
9. Screw in the lateral screw plug.
10. Fill the oil according to mounting position.

3.6 Assembly with the valve

1. Drive the thrust rod completely in and put the actuator onto the valve yoke.
2. Make sure the valve stem is aligned with the center of the bore and at right angles to the actuator seat (permissible parallel deviation < 0.1 mm (0.009 inch) with regard to total stroke).
3. Fasten the actuator to the yoke with slightly oiled screws of property class 8.8 (tensile strength 800 N/mm<sup>2</sup> (116032 pounds/square inch), yield strength 640 N/mm<sup>2</sup> (93550 pounds/square inch)).



**IMPORTANT (NOTE)**

Comply with the fastening torques and thread dimensions in the actuator flange!

Actuator	tightening torque	Flange thread
LME	20 Nm (14.75 lbf-ft)	M8-15 deep
RSD10 / RSD20	175 Nm (129.07 lbf-ft)	M16-20 deep
RSD50	340 Nm (250.77 lbf-ft)	M20-25 deep
RSD100	340 Nm (250.77 lbf-ft)	M20-25 deep

4. Use the hand wheel to drive the thrust rod out; link the rod with the valve stem via the coupling.
5. Manually retract the thrust rod to check whether or not the external stop of the actuator is on the housing flange before the valve cone touches the cover.
6. If required, adjust with the coupling (only possible within certain limits!).

4 Electrical connections



**IMPORTANT (NOTE)**

Refer to the operating instructions of the power electronic unit for the electrical connection diagrams.

## 5 Operation

**WARNING - risk of crushing!**

Danger of injuries due to crushing between external stop and valve yoke / actuator housing!  
Do not reach into the danger zone!

**WARNING - Live components!**

Risk of death or serious injuries due to electricity and unexpected machine movements!  
In automatic mode the motor is always under power, even at standstill!

The motor triggered by the power electronics controls the axially fixed drive sleeve /nut assembly via oil-lubricated spur gears. A ball bearing screw (see Fig. 9) radially fixed by an anti-twist arrester converts the rotary motion to a linear one. The screw is the upper part of the thrust rod and has an adjustable mechanical stop (RSD, only).

A position sensor detects the current thrust rod position via mechanical reduction gearing without backlash.

The motor brake locks the actuator in the current position if the power supply is cut off.



Fig. 9: Ball bearing screw with nut, cross-section

## 5.1 Manual operation

Manual mode allows you to move the actuator manually when the electrical power is off.



### CAUTION - Risk of injury!

When the hand wheel lock is pressed, restoring force from the valve may be present in the hand wheel. To prevent the hand wheel from turning unintentionally, hold the hand wheel with one hand.

1. Press the hand wheel lock.



### IMPORTANT (NOTE)

When the hand wheel is turned clockwise, the thrust rod is retracted at the LME and extended at the RSD10 ... 100.

2. Turn the hand wheel to move the valve stem to the desired position.
3. Release the lock.

## 5.2 Handwheel operation in combination with positioning time-out function

The positioning time-out function of the Contrac power electronic unit monitors the actuator's behavior. It controls whether the travel commands trigger the corresponding processes.

When the supply voltage is switched off, the positioning time-out function is disabled and the handwheel operation is no longer monitored. When the voltage supply is on and the actuator is moved via the handwheel, the time-out monitoring function recognizes this state as "Travel without travel command". The corresponding signal is output.

There are several options to reset this positioning loop error:

- Reset via the commissioning and service field (ISF)
- Reset via the graphic user interface
- Change of the setpoint signal by at least 3 % for more than 1 s
- Wiring of digital inputs DI 2 or DI 3 (not with step controller)

If the "time-out monitoring" function is disabled, the actuator continues to be monitored for "wrong direction", and the corresponding message is generated in case of an error.

## 6 Maintenance



**WARNING - Live components!**

Risk of death or serious injuries due to electricity and unexpected machine movements!  
In automatic mode the motor is always under power, even at standstill!



**WARNING - General risks!**

All maintenance activities may only be performed by properly qualified persons.

Contrac actuators feature a robust construction. As a result, they are highly reliable and require minimal maintenance. The maintenance intervals depend upon the effective load and are therefore not specified here.

The built-in microprocessor evaluates the actual load factors (e.g. torques, forces, temperatures, etc.) and derives the remaining operating time until the next routine maintenance is required.

Use the configuration program to view this information.

### 6.1 Inspection and overhaul

- Only use genuine spare parts such as ball bearings, gaskets, oil and grease to overhaul the actuators.
- Maintenance activities should be performed once the remaining calculated time has expired.
- Inspection or maintenance is due after the time specified in the table.

Overhaul intervals:

Interval	Measures
1 x per year	Visual check of the gaskets for leaks. Remove and change if leaks are present.
Max. every 10 years, preferably once the calculated time before the next maintenance operation has expired	Change oil or grease, roller bearings and gaskets on motor and gearing. Check gear wheels for wear; replace if necessary.

Make sure that no chippings or other material get into the gearbox during the maintenance work.

Don't drive the actuator during the oil check.

6.2 Removing the motor and adjusting the brakes



**WARNING - risk of injury!**

The actuator position may be changed accidentally by the repelling power of the valve when the motor is removed or the brake is released. Make sure that process forces are not exerted on the thrust rod.

Since the brake is permanently released in AUT mode it is not exposed to mechanical wear. Any readjustment is not necessary. Enables users to test the configuration software of the brake.

6.3 Oil change (RSD, only)



**NOTICE!**

Do not mix oils for different temperature ranges. Dispose of old oil according to local regulations. Make sure that the oil does not enter the water cycle.

Proceed as follows to drain or change the oil:

1. Provide a container capable of holding the expected oil quantity acc. to chapter 6.3.1 "Filling capacity".
2. Open and remove the vent valve, see Fig. 6 and Fig. 7.
3. Unscrew the lowermost drain plug and drain the oil.
4. Make sure all the oil is out of the actuator.
5. Screw in and tighten the oil drain plug.
6. Fill the container with the proper oil quantity and tighten the vent valve.

Ambient temperature	Oil types	
	Default oil filled with delivery	Alternative oil
-10 ... 65 °C (15 ... 150 °F)	Castrol Alpha BMB 220 (L-CKC meets ISO TR 3498)	Aral Degol BMB 220 ESSO Spartan EP 220 BP Energol GR-XP 220 Shell Omala 220 Mobilgear 630
-30 ... 50 °C (-20 ... 130 °F)	Mobil SHC 629	–
-1 ... 85 °C (30 ... 185 °F)	Mobil SHC 632	–

**6.3.1 Filling capacity**

<b>RSD10 / RSD20</b>				
Installation position	IMV 1	IMV 3	IMB 5 (handwheel down)	IMB 5
oil quantity, approx. max. stroke 100 mm (4 inches)	3.8 l (1.01 gal. <sup>1)</sup> )	5.4 l (1.43 gal. <sup>1)</sup> )	3.8 l (1.01 gal. <sup>1)</sup> )	3.8 l (1.01 gal. <sup>1)</sup> )
max. stroke 300 mm (11.8 inch)	6.4 l (1.69 gal. <sup>1)</sup> )	8.8 l (2.33 gal. <sup>1)</sup> )	6.4 l (1.69 gal. <sup>1)</sup> )	6.7 l (1.77 gal. <sup>1)</sup> )
oil level below check screw with retracted thrust rod	40 mm (1.57 inch)	0 mm (0 inch)	28 mm (1.10 inch)	75 mm (2.95 inch)

<b>RSD50</b>			
Installation position	IMV 1	IMV 3	IMB 5
oil quantity, approx. max. stroke 120 mm (4.72 inch)	7 l (1.85 gal. <sup>1)</sup> )	10 l (2.65 gal. <sup>1)</sup> )	7 l (1.85 gal. <sup>1)</sup> )
max. stroke 300 mm (11.8 inch)	10 l (2.65 gal. <sup>1)</sup> )	12 l (3.17 gal. <sup>1)</sup> )	9,5 l (2.51 gal. <sup>1)</sup> )
oil level below check screw with retracted thrust rod	49 mm (1.93 inch)	0 mm (0 inch)  150 mm (5.91 inch) (300 mm (11.81 inch) Hub)	95 mm (3.74 inch)

<b>RSD100</b>			
Installation position	IMV 1	IMV 3	IMB 5
oil quantity, approx. max. stroke 150 mm (5.91 inch)	11 l (2.91 gal. <sup>1)</sup> )	18 l (4.76 gal. <sup>1)</sup> )	13 l (3.43 gal. <sup>1)</sup> )
max. stroke 300 mm (11.8 inch)	15 l (3.96 gal. <sup>1)</sup> )	23 l (6.08 gal. <sup>1)</sup> )	9,5 l (2.51 gal. <sup>1)</sup> )
oil level below check screw with retracted thrust rod	47 mm (1.85 inch)	15 mm (0.059 inch) (150 mm (5.91 inch) Hub)  130 mm (5.12 inch) (300 mm (11.81 inch) Hub)	43 mm (1.69 inch)

1) US liquid gallon

**6.4 Grease lubrication (LME, only)**

<b>Basic gearing (except DU sockets)</b>	<b>Recirculating ball screw</b>	<b>Motor mounting</b>
20 g Beacon 325, Esso (manuf.)	20 g Optimol Optipit 08110, Optimol Ölwerke (manuf.)	Beacon 325, Esso (manuf.)
All components must be sufficiently wetted.	The recirculating ball screw must be completely wetted after being actuated several times.	The motor bearings must be completely filled with the lubricant.

## 7 Trouble shooting

This chapter only covers hardware-related errors. For additional troubleshooting information, refer to the online help for the operator interface.

Error	Possible cause	Troubleshooting
Valve cannot be moved by actuator.	Failure either on the actuator or the valve (e.g., stuffing box tightened too much).	Disconnect actuator from valve. If the actuator moves, the valve is the possible cause. If the actuator does not move, the actuator is the possible cause.
The actuator does not respond.	Incorrect electronic unit or incorrect data record.	Compare information on name plates for actuator and electronic unit.
	Incorrectly configured electronic unit.	Check / change. Change the settings via the parameterization software.
	No communication with the control system.	Check wiring.
	Incorrect wiring between actuator and electronic unit.	Check wiring.
	Defective motor/brake.	Check the winding resistance of the motor and brake. Check the brake lock.
	Binary inputs on the electronic unit are not wired.	Make connection.
Brake does not release (no mechanical "click").		Check the brake air gap (approx. 0.25 mm (0.010 inch)) and electrical connection to the brake. Check winding resistance of the brake coil.
Actuator does not run in AUT mode, although "AUT" is selected in the user interface.	Digital input 1 (DI 1) not wired.	Make connection. Check the software settings for the digital inputs.
Actuator does not respond to control (LED 5 flashing at 1 Hz) (software version 2.00 and higher).	Actuator to manual mode (MAN) via ISF.	Switch actuator to automatic mode (AUT).
LEDs in the commissioning and service panel (ISF) are flashing synchronously.	Actuator is not adjusted properly.	Adjust actuator.
LEDs flash alternately.	Electronic unit / drive malfunction.	Drive the actuator beyond the adjusted end position, either manually or using the buttons on the ISF; (if necessary disconnect from valve before). Drive the actuator back into the operating range and connect it to the valve.
Malfunction when approaching the end position.	Actuator in limit range of positioning sensor.	Readjust the actuator for the operating range.

### 7.1 Electrical test values

	EM24	MCS 071 BA	MCS 080 BA	MC 090 BA	MC 100 BA	MC 112 BA
Winding resistance ± 5% at 20 °C (68 °F)						
Motor	L1 (bl.) - L2 (sw): 3.4 Ω L1 (bl.) - L3 (viol.): 3.4 Ω	45.6 Ω	21.6 Ω	19 Ω	7.6 Ω	2.4 Ω
Brake	19.5 Ω	2120 Ω	2120 Ω	1620 Ω	1290 Ω	1059 Ω

## 8 Specifications

### 8.1 LME620

	LME620-AI (integrated electronic unit)	LME620-AN (separate electronic unit)
Operating mode	S9 – 100%; stallproof acc. to IEC 60034-1 / EN 60034-1	
Ingress protection	IP 66 acc. to IEC 60529 / EN 60529 NEMA 4X acc. to CAN/CSA22.2 No. 94	
Humidity	≤ 95% annual average; condensation not permitted	
Ambient temperature	-10 ... 55 °C (15 ... 130 °F) -25 ... 55 °C (-15 ... 130 °F)	-10 ... 65 °C (15 ... 150 °F) -25 ... 55 °C (-15 ... 130 °F)
Transport and storage temperature	-25 ... 70 °C (-15 ... 160 °F)	-40 ... 70 °C (-40 ... 160 °F)
Long-term storage temperature	-25 ... 40 °C (-15 ... 105 °F)	-30 ... 40 °C (-25 ... 105 °F)
Installation position	any position; preferably IMV 1 acc. to IEC 60034-7 / EN 60034-7	
Coating	2-layer component epoxy (RAL 9005, black)	
Anti-condensation heater	-	Optional, separate power supply or power feed from Contrac electronic unit
Power supply for motor and sensors	Only via special electronic unit (refer to the data sheet for the electronic unit)	
Cable between actuator and electronic unit	-	Select from 5 m (16 ft), 10 m (32 ft) or 20 m (65 ft) Max. 30 m (98 ft): for electronic unit EAN823 Max. 480 m (1575 ft): for electronic unit EAN822 (read the data sheet for the electronic unit)

	LME620-AN; LME620-AI
Rated force	4 kN (900 lbf) (adjustable to 0.5 / 0.75 or 1x rated force)
Starting force	1.2 x rated force (break-away torque in end positions for short time 2 x rated force)
Operating speed	2 mm/s (12.7 s/inch) (adjustable from 0.1 mm/s (254 s/inch) to 2 mm/s (12.7 s/inch))
Stroke	Min. 0 ... 12 mm (0 ... 0.47 inch) Max. 0 ... 60 mm (0 ... 2.36 inch)
Weight	LME620-AI: Approx. 21 kg (53 lb) LME620-AN: Approx. 17 kg (44 lb)
Associated electronic unit (data sheet)	LME620-AI: integrated electronic unit LME620-AN: Designed for field installation: EAN823 (10/68-8.26) Designed for rack installation: EAS822 (10/68-8.23)
Motor	24 V 3~ asynchronous motor for operation with electronic unit EAN 823 or EAS 822
Sensors	Position and temperature sensor always available

## Specifications

### 8.2 RSD10 ... 100

	<b>RSD10 ... 100</b>
Operating mode	S9; stallproof acc. to IEC 60034-1 / EN 60034-1
Ingress protection	IP 66 acc. to IEC 60529 / EN 60529 NEMA 4X acc. to CAN/CSA22.2 No. 94
Humidity	≤ 95% annual average; condensation not permitted
Ambient temperature	-10 ... 65 °C (15 ... 150 °F) -30 ... 50 °C (-20 ... 130 °F) -1 ... 85 °C (30 ... 185 °F) <sup>1)</sup>
Transport and storage temperature	-40 ... 70 °C (-40 ... 160 °F)
Long-term storage temperature	-30 ... 40 °C (-25 ... 105 °F)
Installation position	any position; preferably IMV 1; IMV 3; IMB 3 acc. to IEC 60034-7 / EN 60034-7 (additional installation positions available upon request)
Coating	2-layer component epoxy (RAL 9005, black)
Anti-condensation heater (optional)	Motor winding: Directly from the electronic unit Signal space: Separate heating resistor; separate power supply or power feed from Contrac electronic unit
Electrical connection	Plug with crimp snap-in contacts or screw terminals Connecting cable for electronic unit – actuator available as an option (see ordering information for electronic unit)
Power supply for motor and sensors	Only via special electronic unit (refer to the data sheet for the electronic unit)

1) only RSD10 / RSD20

	<b>RSD10-5.0</b>	<b>RSD10-10.0</b>	<b>RSD20-5.0</b>	<b>RSD20-7.5</b>
Rated force	10 kN (2250 lbf) (adjustable to 0.5 / 0.75 or 1x rated force)		20 kN (4500 lbf) (adjustable to 0.5 / 0.75 or 1x rated force)	
Starting force	1.2 x rated force (break-away torque in end positions for short time 2 x rated force)			
Operating speed, adjustable	0.1 ... 5.0 mm/s (254 ... 5 s/inch)	0.1 ... 10.0 mm/s (254 ... 2.5 s/inch)	0.1 ... 5.0 mm/s (254 ... 5 s/inch)	0.1 ... 7.5 mm/s (254 ... 3.4 s/inch)
Stroke	min.: 0 ... 15 mm (0 ... 0.59 inch) / max. 0 ... 100 mm (0 ... 4 inch) or min.: 0 ... 50 mm (0 ... 1.97 inch) / max. 0 ... 300 mm (0 ... 11.8 inch)			
Weight (100 mm (4 inch) stroke) (300 mm (11.8 inch) stroke)	Approx. 57 kg (126 lb) Approx. 82 kg (181 lb)			Approx. 60 kg (132 lb) Approx. 85 kg (187 lb)
Related electronics	For field installation: Model EBN853 <sup>1)</sup> For rack installation: Model EBS852 <sup>2)</sup>			
Motor type	MCS 71 BA			MCS 80 BA
Sensors	Position and temperature sensor always available			

1) Data Sheet EBN853: 10/68-8 27

2) Data Sheet EBS852: 10/68-8 24

	<b>RSD50-3.0</b>	<b>RSD50-10.0</b>
Rated force	50 kN (11240 lbf) (adjustable to 0.5 / 0.75 or 1x rated force)	
Starting force	1.2 x rated force (break-away torque in end positions for short time 2 x rated force)	
Operating speed, adjustable	0.1 ... 3.0 mm/s (254 ... 8.5 s/inch)	0.1 ... 10.0 mm/s (254 ... 2.5 s/inch)
Stroke	min.: 0 ... 20 mm (0 ... 0.79 inch) / max. 0 ... 120 mm (0 ... 4.7 inch) or min.: 0 ... 60 mm (0 ... 2.36 inch) / max. 0 ... 300 mm (0 ... 11.8 inch)	
Weight (120 mm (4.7 inch) stroke) (300 mm (11.8 inch) stroke)	Approx. 130 kg (287 lb) Approx. 168 kg (342 lb)	Approx. 146 kg (322 lb) Approx. 175 kg (377 lb)
Related electronics	For field installation: Model EBN853 <sup>1)</sup> For rack installation: Model EBS852 <sup>2)</sup>	For field installation: Model EBN861 <sup>3)</sup> For rack installation: Model EBS862 <sup>4)</sup>
Motor type	MC 90 BA	MC 100 BA
Sensors	Position and temperature sensor always available	

1) Data Sheet EBN853: 10/68-8 27

2) Data Sheet EBS852: 10/68-8 24

3) Data Sheet EBN861: 10/68-8 22

4) Data Sheet EBS862: 10/68-8 25

	<b>RSD100-1.5</b>	<b>RSD100-10.0</b>
Rated force	100 kN (22500 lbf) (adjustable to 0.5 / 0.75 or 1x rated force)	
Starting torque	1.2 x rated force (break-away torque in end positions for short time 2 x rated force)	
Operating speed, adjustable	0.1 ... 1.5 mm/s (254 ... 17 s/inch)	0.1 ... 10.0 mm/s (254 ... 2.5 s/inch)
Stroke	min.: 0 ... 25 mm (0 ... 0.98 inch) / max. 0 ... 150 mm (0 ... 5.9 inch) or min.: 0 ... 60 mm (0 ... 2.36 inch) / max. 0 ... 300 mm (0 ... 11.8 inch)	
Weight (150 mm (5.9 inch) stroke) (300 mm (11.8 inch) stroke)	Approx. 215 kg (474 lb) Approx. 275 kg (606 lb)	Approx. 242 kg (534 lb) Approx. 273 kg (602 lb)
Related electronics	For field installation: Model EBN853 <sup>1)</sup> For rack installation: Model EBS852 <sup>2)</sup>	For field installation: Model EBN861 <sup>3)</sup> For rack installation: Model EBS862 <sup>4)</sup>
Motor type	MC 90 BA	MC 112 BA
Sensors	Position and temperature sensor always available	

1) Data Sheet EBN853: 10/68-8.27

2) Data Sheet EBS852: 10/68-8.24

3) Data Sheet EBN861: 10/68-8.22

4) Data Sheet EBS862: 10/68-8.25

## 9 Appendix

### 9.1 Other applicable documents

- Data Sheet LME620-AI / AN (10/68-2.73)
- Data Sheet RSD10 / RSD20 (10/68-2.75)
- Data Sheet RSD50 (10/68-2.77)
- Data Sheet RSD100 (10/68-2.79)
- Data Sheet EAS822 (10/68-8.23)
- Data Sheet EAN823 (10/68-8.26)
- Data Sheet EBS852 (10/68-8.24)
- Data Sheet EBN853 (10/68-8.27)
- Data Sheet EBS862 (10/68-8.25)
- Data Sheet EBN861 (10/68-8.22)
- Operating Instructions for Power Electronic Units EAS822, EBS852, EBS862 (Cabinet Mounting) (OI/EAS822/EBS852/EBS862)
- Operating Instructions for Power Electronic Units PME120-AI, LME620-AI (Integrated) and EAN823, EBN853, EBN861 (Field-Mounting) (OI/PME/LME/EAN823/EBN853/EBN861)
- Configuration and Parameterization Instructions (45/68-10)
- Technical Information (30/68-104)

### 9.2 Approvals and certifications

CE mark		<p>The version of the meter in your possession meets the requirements of the following European directives:</p> <ul style="list-style-type: none"> <li>- EMC directive 2004/108/EC</li> <li>- Machinery directive 2006/42/EC</li> </ul>
---------	---	---



#### IMPORTANT (NOTE)

All documentation, declarations of conformity, and certificates are available in ABB's download area.

[www.abb.com/instrumentation](http://www.abb.com/instrumentation)



#### IMPORTANT (NOTE)

The original EC declaration of conformity is delivered with the device.



**EG-KONFORMITÄTSERKLÄRUNG**  
*EC DECLARATION OF CONFORMITY*

**Hersteller / Manufacturer:** ABB Automation Products GmbH  
Minden  
**Anschrift / Address:** Schillerstraße 72  
D-32425 Minden  
**Produktbezeichnung:** Elektrischer Regelantrieb CONTRAC  
*Product name:* Electrical Actuator CONTRAC

Das folgende Produkt / *The following product*

**Typ / Type:**

**Fabriknummer / Serial number:**

**Herstelldatum / Date of manufacture:**

stimmt mit den Vorschriften folgender Europäischer Richtlinien überein:  
*meets the requirements of the following European directives:*

2006/42/EG 2006/42/EC	Richtlinie Maschinen <i>Directive on Machinery</i>
2004/108/EG 2004/108/EC	EMV-Richtlinie <i>Electromagnetic Compatibility Directive</i>

Die Übereinstimmung mit den Vorschriften dieser Richtlinien wird nachgewiesen durch die vollständige Einhaltung folgender Normen:

*Conformity with the requirements of these Directives is proven by complete adherence to the following standards:*

EN 12100-1 / EN 12100-2 / EN 60204-1  
EN 61 000-6-2 / EN 61 000-6-4 / EN 50 178

Die bezeichneten Produkte sind ausschließlich zum Einbau in eine Maschine bestimmt. Die Inbetriebnahme darf erst vorgenommen werden, nachdem die Konformität des Endproduktes mit den oben genannten Richtlinien festgestellt wurde. Die Sicherheitshinweise der mitgelieferten Dokumentation sind zu beachten.

*The designated products are determined exclusively for installation on a machine. The introduction may only be carried out after the conformity of the final product with the above-mentioned guidelines was found. The safety remarks of the supplied documentation have to be observed.*

**Dokumentationsbevollmächtigter:** Dr. Wolfgang Scholz  
*Authorised person for documentation:*

**Anschrift / Address:** Siehe Anschrift des Herstellers  
*Refer to address of manufacturer*

14.06.2011

**Datum**  
*Date*

*ppa.*

**Axel Bredemeyer**  
**Standortleiter Minden**  
Head of Location Minden

*i.v.*

**Dr. Wolfgang Scholz**  
**Leiter R&D**  
Head of R&D

## Statement on the contamination of devices and components

Repair and / or maintenance work will only be performed on devices and components if a statement form has been completed and submitted.

Otherwise, the device / component returned may be rejected. This statement form may only be completed and signed by authorized specialist personnel employed by the operator.

### Customer details:

Company:

Address:

Contact person:

Telephone:

Fax:

E-mail:

### Device details:

Type:

Serial no.:

Reason for the return/description of the defect:

### Was this device used in conjunction with substances which pose a threat or risk to health?

Yes       No

If yes, which type of contamination (please place an X next to the applicable items)?

Biological            Corrosive / irritating            Combustible (highly / extremely combustible)     

Toxic            Explosive            Other toxic substances     

Radioactive     

Which substances have come into contact with the device?

1.

2.

3.

We hereby state that the devices / components shipped have been cleaned and are free from any dangerous or poisonous substances.

Town/city, date

Signature and company stamp

**10 Index**

<b>A</b>	
Accessibility .....	16
Actuator check .....	16
Adaptation of actuator stroke to the valve stroke .....	19
Adjustments .....	10
Alternative oil .....	24
Ambient temperature .....	24
Appendix .....	30
Approvals and certifications .....	30
Assembly with the valve .....	20
Automatic mode .....	24
<b>B</b>	
Brake adjustment .....	24
<b>C</b>	
Calculated time before next maintenance operation is required .....	23
Commissioning .....	9
Contamination of devices .....	32
<b>D</b>	
Desiccant .....	9
Design and function .....	14
Disposal .....	13
<b>F</b>	
Filling capacity .....	24, 25
Functionality .....	15
<b>G</b>	
Gearing .....	17
General information and notes for the reader .....	5
Grease lubrication .....	25
<b>H</b>	
Hazardous materials .....	12
Heat sources .....	16
<b>I</b>	
Information on WEEE Directive 2002/96/EC .....	13
Inspection and overhaul .....	23
Installation instructions .....	16
Installation position .....	17
Installation safety information .....	10
Installation site .....	16
Integrated management system .....	13
Intended use .....	5
<b>L</b>	
Load pick-up device .....	10
<b>M</b>	
Maintenance .....	23
Maintenance activities .....	23
Maintenance intervals .....	23
Manual operation .....	22
Mounting .....	16
Mounting position .....	16
<b>N</b>	
Name plate .....	7
Note symbols .....	6
<b>O</b>	
Oil change .....	11, 24
Oil drain plug .....	24
Oil quantity .....	24
Oil types .....	8, 24
Old oil .....	11, 24
Operating safety information .....	11
Operation .....	21
Other applicable documents .....	30
Overhaul .....	23
<b>P</b>	
Plates and symbols .....	6
Position sensor .....	21
Process forces .....	11, 24
<b>R</b>	
Rated force .....	16
Repelling power .....	11
Returning devices .....	12
RoHS Directive 2002/95/EC .....	13
<b>S</b>	
Safety .....	5
Safety information for electrical installation .....	10
Specifications .....	27
Storage conditions .....	9
Storage period .....	9
<b>T</b>	
Target groups and qualifications .....	5
Temperature ranges .....	24
Thrust rod cover .....	19
Transport .....	9
Transport safety information .....	9
Transport temperatures .....	9
Trouble shooting .....	26
Type designation .....	8
<b>V</b>	
Valve requirements .....	16
Vent valve .....	16
<b>W</b>	
Warranty .....	5

## Index

---

Warranty provisions .....	5	Wear .....	23
---------------------------	---	------------	----



---

ABB has Sales & Customer Support expertise in over 100 countries worldwide.

[www.abb.com/instrumentation](http://www.abb.com/instrumentation)

The Company's policy is one of continuous product improvement and the right is reserved to modify the information contained herein without notice.

Printed in the Fed. Rep. of Germany (09.2011)

© ABB 2011

3KXE161008R4201



**ABB Ltd.**  
**Process Automation**  
Salterbeck Trading Estate  
Workington, Cumbria  
CA14 5DS  
UK  
Tel: +44 (0)1946 830 611  
Fax: +44 (0)1946 832 661

**ABB Inc.**  
**Process Automation**  
125 E. County Line Road  
Warminster, PA 18974  
USA  
Tel: +1 215 674 6000  
Fax: +1 215 674 7183

**ABB Automation Products GmbH**  
**Process Automation**  
Schillerstr. 72  
32425 Minden  
Germany  
Tel: +49 551 905-534  
Fax: +49 551 905-555