

Extension and Compensating Cables

	Page
Introduction	2
General information	2
Materials for extension and compensating cables	2
EMF, tolerances and temperature ranges	2
Standardized materials and colour codes	3
Tolerances and temperature ranges according to DIN 43 722	4
Tolerances of external dimensions	4
Insulating Materials	5
Effective Capacity	5
Technical Data	6
Insulation resistance	6
Test voltages	6
Inductivity	6
Tolerance of loop resistance	6
Marking of pairs	6
Loop resistance	6
Computer Application	7
General information	7
Types of interference voltage	7
Remedies	7
Cabling	8
Earthing	8
Installation of Shielding	9
Compensating Cables for Explosion-proof Installations	9
Installation Instructions	10
Cable types	10
Installation	10
Permissible traction	10
Supplementary length	10
Control	10
Cable bedding	10
Permissible temperature ranges for installation	10
Delivery Program	11
Technical Terms of Delivery	11
Fibreglass-insulated Cables	12
PVC-insulated Cables	14
Silicone rubber-insulated Cables	20
Teflon-insulated Cables	25

Copper Cables

Copper Cables	29
--------------------------------	----

Extension and Compensating Cables**Introduction - Materials****General Information**

An electrical temperature measuring system with a thermocouple as the measuring sensor consists essentially of the thermocouple with the measuring point, the hot junction, a reference point with a known temperature, the cold junction, and a voltmeter. The temperature difference between the hot junction and the cold junction is measured.

The cold junction temperature must, therefore, be known in order to be able to make a statement about the temperature at the hot junction. It is expedient to ensure that the cold junction temperature is kept at a constant value by means of suitable measures (ice water, thermostat).

The leads from the cold junction to the measuring instrument are of normal copper wire.

Often it is necessary to arrange the cold junction at some distance from the hot junction for reasons of design, finance or safety. In other cases, the measuring circuit is installed permanently and the actual thermocouple is designed as a measuring insert so that it can easily be replaced.

It is then necessary to have a connection cable between the thermocouple and the cold junction with the same thermoelectric properties as the thermocouple itself.

This connection is the compensating or extension cable.

Materials for Extension and Compensating Cables according to DIN 43 722

We distinguish between original materials for extension cables and substitute materials for compensating cable.

Extension wires of original materials are made of the same material as the accompanying thermocouple and can be used for measurements up to 200 °C (type TX DIN 43 722 only up to 100 °C).

Compensating wires of substitute materials consist of alloys which are not identical to the accompanying thermocouple. However, within the permissible temperature range for compensating cables (see DIN 43 722), they have the same thermoelectric properties as the accompanying thermocouple.

Substitute materials are used for the thermocouples type K and N and for the precious metal thermocouples type R, S and B, as the thermal material in these thermocouples consists of very expensive materials and the substitute materials are considerably cheaper.

Another positive property of the substitute materials, namely the lower ohmic resistance, is no longer significant today. Modern electronic measuring instruments have a very high input resistance so that cable resistances in the thermocouple measuring circuit cause no significant measuring error even at values of several kilohms.

The table on the next page provides an overview of the standards, materials and color coding of extension and compensating cables.

EMF, Tolerances and Temperature Ranges

Wires for extension and compensating cables are standardized in DIN 43 713 or 43 712. The EMF in the permissible temperature range corresponds to the EMF for the thermocouples according to DIN EN 60 584-1.

Tolerances for extension and compensating cables are specified in DIN 43 722. There are two accuracy classes.

The narrower accuracy class 1 is only supplied for extension cables, i.e. cables with original materials.

Class 2 applies to both extension cables and compensating cables.

The extension and compensating cables in this catalog comply with DIN 43 722, in terms of color coding, apart from extension cables type U and L, which are coded according to DIN 43 714. The tolerances comply with accuracy class 2 according to DIN 43 722.

The tolerance according to DIN 43 710 of ± 3 °C applies to thermocouples of types U and L.

Extension cables in accuracy class 1 are available on request.

For thermocouple type B, copper conductors can be used in the temperature range up to 100 °C. Therefore no tolerances are specified in DIN 43 722 for type B.

Within the range from 0 °C to 100 °C is to be expected a maximal additional tolerance of 40 μ V corresponding 3.5 °C (at measuring point temperature 1400 °C). If compensating cables have to be used for type B at high temperatures, it is necessary to use a special compensating cable. These cables are available on request.

Extension and Compensating Cables
--

Standardized Materials and Color Codes

Standard	Type of thermocouple			Material for compensating or extension cable			Colour code		Sheath
	Type	positive	negative	Code	positive	negative	positive	negative	
DIN 43 722 -1994 JIS C1610 -1995	T	Cu	CuNi	TX	Cu	CuNi	brown	white	brown
	E	NiCr	CuNi	EX	NiCr	CuNi	violet	white	violet
	J	Fe	CuNi	JX	Fe	CuNi	black	white	black
	K	NiCr	Ni	KX	NiCr	Ni	green	white	green
	K	NiCr	Ni	KC A	Fe	CuNi	green	white	green
	K	NiCr	Ni	KC B	Cu	CuNi	green	white	green
	N	NiCrSi	NiSi	NX	NiCrSi	NiSi	pink	white	pink
	N	NiCrSi	NiSi	NC	E-Cu	CuNiMn	pink	white	pink
	R/S	Pt13/10Rh	Pt	RC A/SC A	E-Cu	CuNiMn	orange	white	orange
	R/S	Pt13/10Rh	Pt	RC B/SC B	E-Cu	CuNiMn	orange	white	orange
B	Pt30Rh	Pt6Rh	BC	CuMn	E-Cu	grey	white	grey	
ANSI MC 96.1- 1982	T	Cu	CuNi	TX	Cu	CuNi	blue	red	blue
	E	NiCr	CuNi	EX	NiCr	CuNi	purple	red	purple
	J	Fe	CuNi	JX	Fe	CuNi	white	red	black
	K	NiCr	Ni	KX	NiCr	Ni	yellow	red	yellow
	R/S	Pt13/10Rh	Pt	RX/SX	E-Cu	CuNiMn	black	red	green
B	Pt30Rh	Pt6Rh	BX	CuMn	E-Cu	grey	red	grey	
NF C42-324- 1985	T	Cu	CuNi	TX/C	Cu	CuNi	yellow	blue	blue
	E	NiCr	CuNi	EX/C	NiCr	CuNi	yellow	orange	orange
	J	Fe	CuNi	JX/C	Fe	CuNi	yellow	black	black
	K	NiCr	Ni	KX/C	NiCr	Ni	yellow	violet	violet
	K	NiCr	Ni	VC	Cu	CuNi	yellow	brown	brown
	K	NiCr	Ni	WC	Fe	CuNi	yellow	white	white
	R/S	Pt13/10Rh	Pt	SC	E-Cu	CuNiMn	yellow	green	green
B	Pt30Rh	Pt6Rh	BC	CuMn	E-Cu	yellow	grey	grey	
DIN 43 714 -1979	U	Cu	CuNi		Cu	CuNi	red	brown	brown
	L	Fe	CuNi		Fe	CuNi	red	blue	blue
	K	NiCr	Ni		Fe	CuNiMn	red	green	green
	R/S	PtRh	Pt		E-Cu	CuNiMn	red	white	white
BS 4937	T	Cu	CuNi		Cu	CuNi	white	blue	blue
	J	Fe	CuNi		Fe	CuNi	yellow	blue	black
	E	NiCr	CuNi		NiCr	CuNi	brown	blue	brown
	K	NiCr	Ni		NiCr	Ni	brown	blue	red
	K	NiCr	Ni		E-Cu	CuNiMn	white	blue	red
	R/S	PtRh	Pt		E-Cu	CuNiMn	white	blue	green

Extension and Compensating Cables

**Tolerances and Temperature Ranges
acc. to DIN 43 722**

The following table shows the specified tolerances for extension cables and compensating cables when used at temperatures within the ranges indicated as 'Cable temperature range'. The table also includes, in parentheses, the approximate equivalent

tolerances in degrees Centigrade. As thermocouple EMF-temperature relationships are non-linear, the tolerance in degrees Centigrade depends on the temperature of the measuring junction of the thermocouple. The figures shown in the table for the specified tolerances in degrees Centigrade are appropriate for the measuring temperatures in the final column.

Type	Accuracy class		Cable temperature range	Measuring junction temperature
	Class 1	Class 2		
JX	± 85 µV (± 1.5 °C)	±140 µV (± 2.5 °C)	-25 °C up to +200 °C	500 °C
TX	± 30 µV (± 0.5 °C)	± 60 µV (± 1.0 °C)	-25 °C up to +100 °C	300 °C
EX	±120 µV (± 1.5 °C)	±200 µV (± 2.5 °C)	-25 °C up to +200 °C	500 °C
KX	± 60 µV (± 1.5 °C)	±100 µV (± 2.5 °C)	-25 °C up to +200 °C	900 °C
NX	± 60 µV (± 1.5 °C)	±100 µV (± 2.5 °C)	-25 °C up to +200 °C	900 °C
KCA	–	±100 µV (± 2.5 °C)	0 °C up to +150 °C	900 °C
KCB	–	±100 µV (± 2.5 °C)	0 °C up to +100 °C	900 °C
NC	–	±100 µV (± 2.5 °C)	0 °C up to +150 °C	900 °C
RCA	–	± 30 µV (± 2.5 °C)	0 °C up to +100 °C	1000 °C
RCB	–	± 60 µV (± 5.0 °C)	0 °C up to +200 °C	1000 °C
SCA	–	± 30 µV (± 2.5 °C)	0 °C up to +100 °C	1000 °C
SCB	–	± 60 µV (± 5,0 °C)	0 °C up to +200 °C	1000 °C
BC	–	± 40 µV (± 3.5 °C)	0 °C up to +100 °C	1400 °C

Tolerances of the External Dimensions

The table shows the tolerances of the outer diameters for the insulation used in this catalogue for the extension and compensating cables.

For all nominal dimensions indicated in the catalogue, the following tolerances are valid (all dimensions in mm):

Type		Nominal dimensions (mm)					
		up to 2.99 mm	3 - 5.99 mm	6 - 9.99 mm	10 - 14.99 mm	15 - 19.99 mm	20 - 29.99 mm
oval cables	JJ	± 0.15	± 0.20	± 0.30	–	–	–
	GLGL	± 0.20	± 0.30	± 0.40	–	–	–
	SL/SLGL	± 0.20	± 0.30	± 0.40	–	–	–
	TT	± 0.15	± 0.20	± 0.30	–	–	–
	outside braid	± 0.30	± 0.40	± 0.50	–	–	–
round cables		± 0.15	± 0.20	± 0.30	± 0.40	± 0.50	± 0.80

Extension and Compensating Cables

Insulating Materials

The choice of insulating material is mainly determined by its type of application. Very often insulating materials are needed for higher temperatures (200 °C and higher), as the cables must be led into close vicinity to the measuring junction, or laid through hot zones.

The following table gives a summary of the characteristics of the most important insulating materials.

The values should be considered only as reference values, and should not be used as minimum requirements in specifications.

Compensating cables for underground installation require particular conditions with regard to protection against humidity.

Reference Values for the most important Characteristics of Insulating Materials of Compensating Cables

		PVC normal	PVC heat-resistant	Silicone rubber	Chloroprene rubber	Fibreglass	Teflon FEP	Teflon PTFE
Dielectric coefficient	μr	5.5-6.5	5.0-6.0	2.3	3		2.1	2.1
Resistivity at 20 °C	Ω · cm	10 ¹²	10 ¹⁴	> 10 ¹⁴	10 ⁹ - 10 ¹²		> 2 · 10 ¹⁸	> 10 ¹⁸
Tensile strength	kN	1250	1250	400	1000-2500		1900-2200	1750-2700
Max. operating temperature	°C	70	105	200	80	400	205	260
Specific weight	g/cm ³	1.3	1.3	1.15 - 1.3	1.35 - 1.65		2.14 - 2.17	2.14 - 2.19
Admissible radiation dose at 25 % damage	rad	10 ⁸	10 ⁸	4 · 10 ⁶	5 · 10 ⁷	10 ¹⁰	3 · 10 ⁴	3 · 10 ⁴
Inflammability		A	A	A	A	B	C	C
Water absorption		little	little	little	little	none	none	none
Suitability in steam		good	good	partially resistant	good	bad	very good	very good
chemical resistance to	weak alkaline solutions	+	+	+	+	-	+	+
	weak acids	+	+	+	+	-	+	+
	alcohol	+	+	+	+	○	+	+
	gasoline	+	+	-	○	○	+	+
	benzene	-	-	-	-	○	+	+
	mineral oil	+	+	+	+	○	+	+

A = self-extinguishing
B = non-combustible

C = non-inflammable
+ = resistant

○ = partially resistant
- = non-resistant

Effective Capacities

The effective capacity depends on the type of insulating material and the physical dimensions of the cable. Guide values are as follows:

Conductor dimensions	Effective capacity (guide values) nF/km				
	PVC insulation	PVC insulation with shielded pair	FEP insulation	FEP insulation with shielded pair	Rubber and silicone rubber insulation
solid Ø 0.80 mm	125	215	50	90	50
solid Ø 1.38 mm	135	245	60	120	70
stranded 0.22 mm ²	115	180	45	70	45
stranded 1.50 mm ²	135	235	60	170	75

Extension and Compensating Cables

Technical Data

The following technical data applies to all cables listed in the catalog; further information can be found on the corresponding pages.

Insulation Resistance

Cables with PVC, rubber, silicone rubber or teflon insulation have an insulation resistance between conductors and between conductors and shielding > 10 MΩ · km.

Test Voltage

All compensating cables are voltage-tested according to the German standard VDE 0472 with the following test voltages being applied:

PVC, rubber, silicone rubber and teflon-insulated cables:

	Test voltage
Conductor to conductor	1000 V
Conductor to shield	1000 V
Shield to shield	500 V
Shield to common shield	500 V

Fibreglass-insulated cables:

Conductor to conductor	500 V
------------------------	-------

Inductivity

Standard values for all PVC, teflon, rubber and silicone rubber-insulated cables < 1mH/km.

Tolerance of Loop Resistance

For all cables, loop resistances have a tolerance of ± 10 %.

Marking of Pairs

In the case of compensating cables with more than four conductors, the individual pairs are marked.

Loop resistance at 20 °C in Ω/km									
Thermocouple type	Conductor material Standards				Conductor dimensions				
	DIN 43712	ANSI MC 96.1	BS 4937	NF C 42-324	Conductor size, mm ²				
					0.22	0.50	0.75	1.30	1.50
	solid conductors				0.50	0.80	1.0	1.29	1.38
stranded conductors				7/0.2	16/0.2	24/0.2	42/0.2	48/0.2	
R/S	RC/SC	SX	RX/SX	SC	622	274	182	105	91
B	BC	BX	BX	BC	645	284	189	109	95
J	JX	JX	JX	JX/JC	2772	1220	813	469	407
T	TX	TX	TX	TX/TC	2304	1014	676	390	338
E	EX	EX	EX	EX/EC	6000	2640	1760	1015	880
K	KX	KX	KX	KX/KC	4500	1980	1320	761	660
K	KCB	–	VX	VC	2304	1014	676	390	338
K	KCA	–	–	WC	2395	1054	702	405	351
N	NX	–	–	–	6000	2640	1760	1015	880
N	NC	–	–	–	2440	1074	716	413	358
L	L	–	–	–	2772	1220	813	469	407
U	U	–	–	–	2304	1014	676	390	338

Table: Loop resistance for various thermocouple types

Extension and Compensating Cables

Computer Application

General Information

Due to the introduction of process computers and electronic measuring instruments connecting cables have to meet particular requirements.

A computer can only work properly when the analog signal which is to be processed, is supplied to it without any superimposed interference.

A process computer determines the momentary value of a process variable.

The analog signal is interrogated for only a few microseconds. In general, the interrogation time is between 20 and 600 μ s.

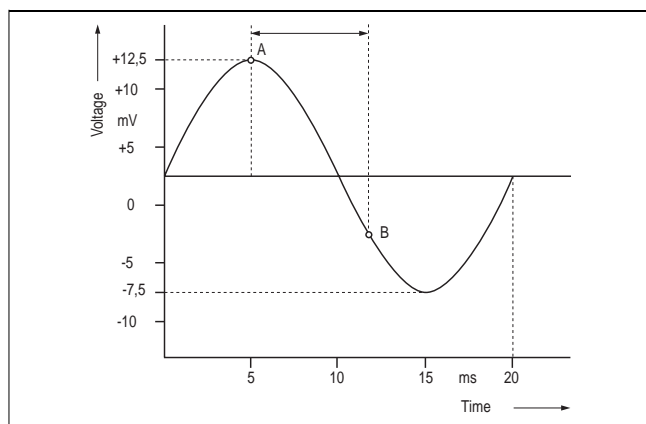

Figure 1

Figure 1 shows the curve of a 50 Hz interference with an amplitude of 10 mV superimposed on the analog signal of 2.5 mV.

It can be seen that, with the above interrogation times, virtually a momentary value of the varying interference voltage is recorded.

Types of Interference Voltage

Two types of interference can occur at the analog signal input of a computer:

1. Normal mode noise
2. Common mode noise

Normal mode noise is the superimposition of a noise voltage source in series with the analog signal voltage source.

The computer input consists of both the interference voltage and the information signal (see Fig. 2).

Common mode noise originates from potential difference between a reference potential and the two input terminals (see Fig. 3).

Common mode noise does not cause interference problems, if prevented from changing into normal mode noise.

This means that common mode noise currents must be avoided in instrument leads, as such currents cause normal mode noise voltage due to the existing lead resistances.

In summary: a correct earth connection is therefore essential. There may be only one earth point in a measuring circuit.

All measures to suppress interference voltage should aim to prevent interference voltage occurring at the computer input.

Preventing interference by filtering is complicated and expensive, and often leads to a phase shift of the signal, which can result in the course of the process being impaired.

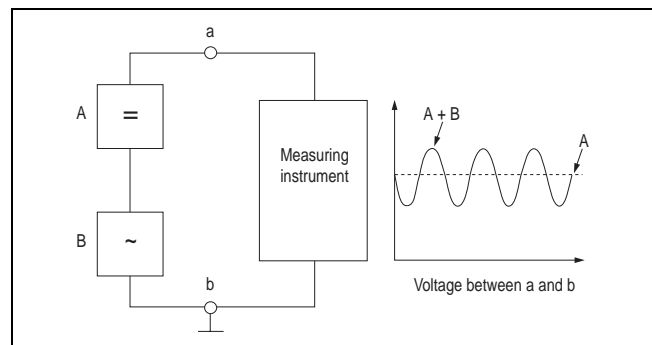

Figure 2
Measuring-circuit voltage A and interference voltage B are superimposed; they are equally effective as error voltages at terminals a and b of the measuring instrument. The earthing of conductor b is therefore of no importance.

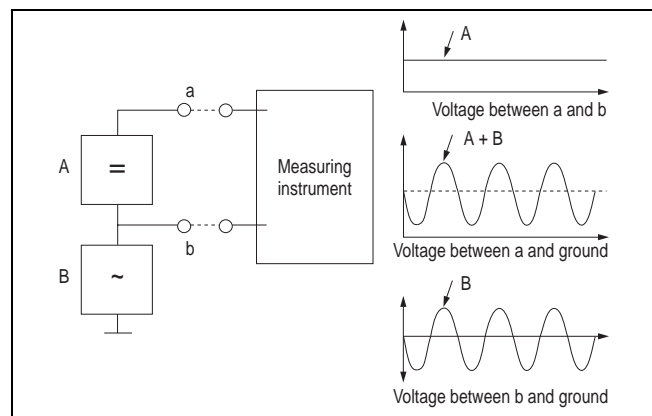

Figure 3
Contrary to figure 2, interference voltage appears here as an in-phase voltage. The interference voltage can only penetrate into the measuring circuit if a circuit is also closed, for example for B, via any earth connection of the measuring instrument still present.

Remedies

The following measures have proved effective in overcoming some of the difficulties referred to:

1. Do not run instrument connecting leads closer to adjacent power lines than the specified minimum distance.
2. Ensure that all instrument leads consist of twisted pairs of conductors.
3. When possible, install instrument leads in tubes of ferromagnetic material.
4. Shield the instrument leads.

Extension and Compensating Cables

Cabling

The following recommended distances between power lines and instrument leads should be observed:

Power line load	Minimum distance between power line and instrument lead
125 V, 10 A	30 cm
250 V, 50 A	45 cm
440 V, 200 A	60 cm
5 KV, 800 A	120 cm

These distances are valid for cables which have a coverage of at least 85%.

Earthing

In order to set up a reliable and precise measuring point, each analog input circuit must be provided with a stable earth connection.

An earth connection with constant resistance is preferable to a small earth resistance as fluctuating earth potentials are particularly harmful.

Multiple earthing must be avoided.

For every input circuit, there is a best earth connection:

Thermocouple insulated against earth and compensating cable shielded.

The earth connection is made via the shield from the computer housing. The shield is always connected to the negative leg of the thermocouple (Fig. 4).

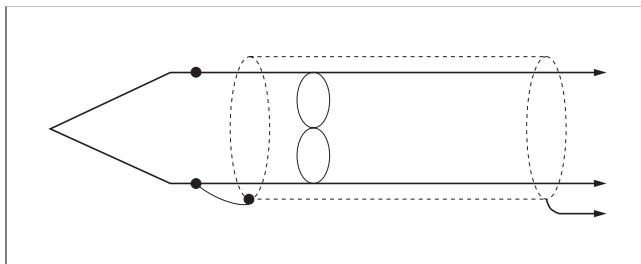

Figure 4
Unearthed thermocouple.
Twisted, shielded compensating cable.

Unshielded Compensating Cable

The earth connection is made at the thermocouple as near as possible to the hot junction (Fig. 5).

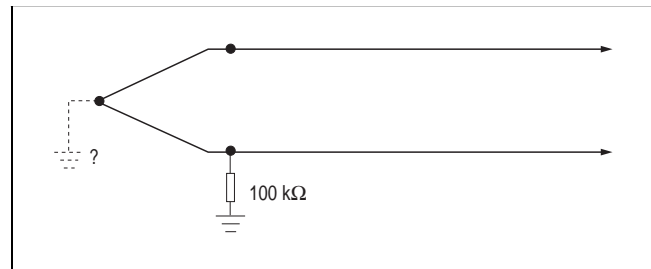

Figure 5
Thermocouple with uncertain earth connection.
Compensating cable not twisted, not shielded.

All other cases:

The earth connection is made directly at the thermocouple as near as possible to the hot junction.

The shield is connected to the negative leg of the thermocouple.

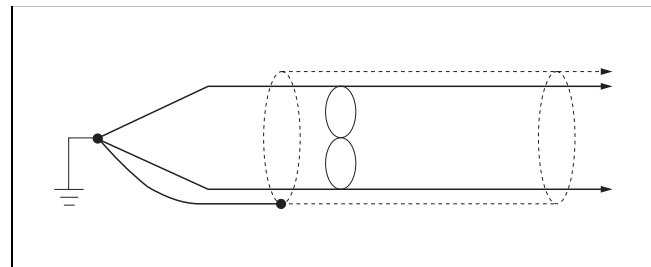

Figure 6
Shielded thermocouple with earthed soldered junction.
Twisted compensating cable.

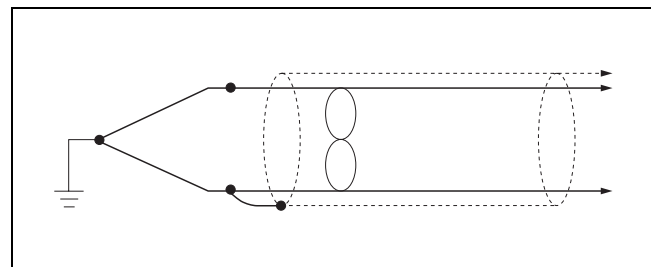

Figure 7
Thermocouple with earthed soldered junction.
Shielded compensating cable.

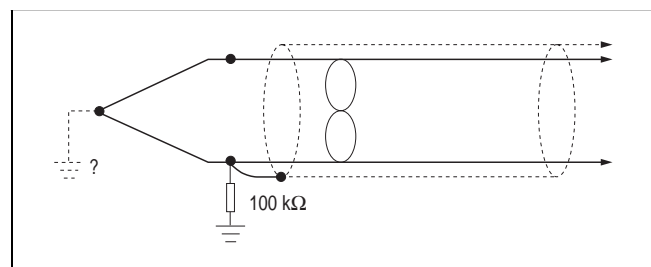

Figure 8
Thermocouple with uncertain earth connection.
Twisted, shielded compensating cable.

Extension and Compensating Cables

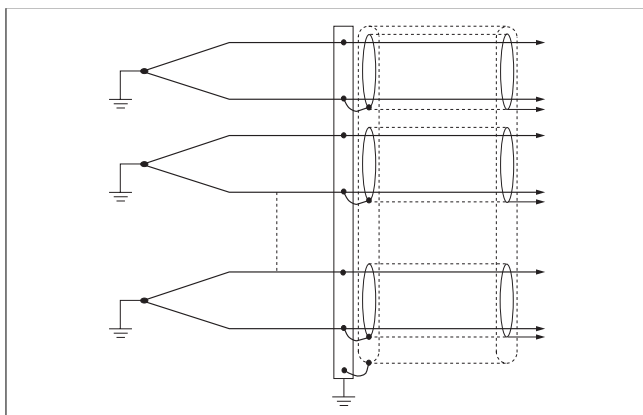

Figure 9
Individually unshielded thermocouples and compensating cables connected to multi-core compensating cables twisted in pairs with individual and overall shielding.

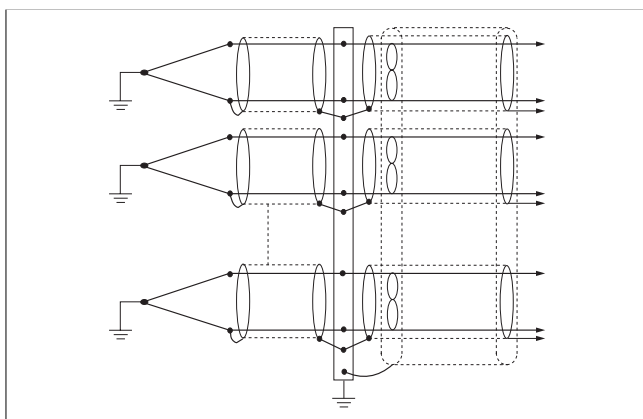

Figure 10
Individually twisted, shielded compensating cables connected to multi-core compensating cables with individually twisted conductor pairs. Shielding around individual pairs and cable.

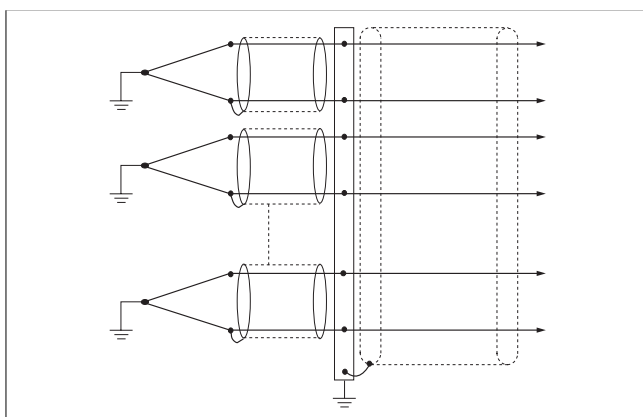

Figure 11
Individually twisted, shielded compensating cables connected to multi-core cable with outer shielding.

Earthing Resistance

The earthing resistance must be between 0 and 10^7 Ohm. However, during operation it must not deviate more than 20 % .

Thermocouples in thermowells often have a variable insulation resistance.

In such cases, it is recommended to proceed as shown in figures 5 and 8.

The carbon resistor of 100 kOhm and 0.5 W loading capacity should be connected as near as possible to the hot junction of the thermocouple.

For precise measurements, circuits according to figures 6, 7, 9, 10 and 11 are recommended.

Installation of Shielding

The shielding must not be electrically interrupted, and a special terminal should be provided on the terminal block for connection purposes.

All cable shields must be insulated from each other.

A connection, interruption, or earthing of shields may take place only where the circuit requires it. The shielding must always be connected to the negative leg of the thermocouple and the connection should be made as near to the hot junction as possible (Figure 12).

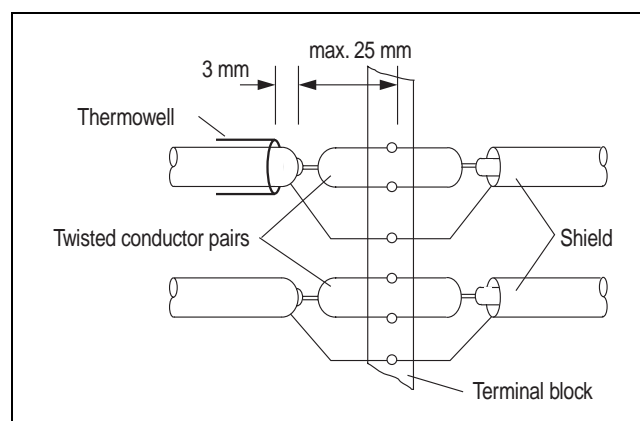

Figure 12
Connection of shields to terminal blocks. The thermowell must reach up to 3 mm from the end of the shield. Detached shields must be protected by adhesive tape.

Compensating Cables for Explosion-proof Installations

Compensating cables for all degrees of protection except for the intrinsically safe degree of protection:

Within the scope of the regulations of VDE 0165/6.80 § 18, a series of compensating cables is suitable for installation in hazardous areas. The PVC-insulated cables of types JJ, JFJ, and J2FFJ are suitable here above all.

Special colour coding of these compensating cables is not necessary.

Compensating cables for intrinsically safe installations:

All types of compensating cables may be used for intrinsically safe installations; however, it must be ensured that the cables are coded in blue, in accordance with the regulations of VDE 0165/6.80 § 8.

Compensating cables with blue colour coding can be supplied on special request.

Extension and Compensating Cables

Installation Instructions

These instructions apply to the installation of compensating and extension cables; they must be observed in order to comply with our warranty conditions.

Types of Cable

These instructions apply to the following types of cable:

- Compensating or extension cables with fibreglass insulation
- Compensating or extension cables with PVC insulation
- Compensating or extension cables with silicone rubber and rubber insulation
- Compensating or extension cables with teflon insulation

Installation

When installing the cables, special care must be taken to ensure that any penetration of moisture into the cables is effectively prevented. Therefore, special measures are necessary if the cables are pulled in with a pulling lug or similar instead of with a cable grip. Provided that no particular specifications exist (e.g. for cables with special armoring), the following approximate values for the installation process are to be observed:

Permissible Traction

The permissible traction is summarised below for the most commonly used types of compensating cables; the details given are also applicable to similar types of cable.

Cable with an armoring of steel wire braiding

The traction is largely absorbed by the armoring; the conductors are not affected to any great degree. The permissible traction P_{perm} is calculated using the permissible stress $\sigma_{perm} = 30 \text{ kp/mm}^2$ for steel wire braiding and the cross-section F_B of the armoring:

$$P_{perm} = \sigma_{perm} \cdot F_B$$

Non-armoured cables

The traction is transmitted to the conductors, and in order to determine the permissible traction, the total cross-section of all the conductors must be taken into consideration. For cables with copper braiding, 80% of the cross-section of the braiding can be included. The permissible stress σ_{perm} for copper conductors and copper braiding is 5 kp/mm^2 .

Cable with metal tape shielding

Most of the traction is transferred to the conductors, as the tape cannot absorb any significant forces. To determine the permissible traction, the total cross-section of the conductors must be taken into consideration.

Permissible bending radius

When installing a cable, the approximate value for the permissible bending radius for cables should not be below $15 \times$ outer diameter. When pulling the cable, the bending radius must be ensured with the help of corner rollers.

These details apply provided no special requirements exist. If the cable is bent only once, for example before end connections, in curves, etc., the permissible bending radius can be reduced at the most by half if the utilisation of the reduced radius is handled correctly and carefully (by heating up to $30 \text{ }^\circ\text{C}$ and bending over a mould).

Supplementary Length

With regard to the strain on the ends as a result of the cable being pulled, sufficient overlength should be provided for at the socket joints. It is recommended to pull each cable at least 2 metres past the middle of the socket joint. The additional metres must be taken into consideration when calculating the length required.

Control

In order to prevent damage to cables during installation, the following must be observed:

1. control of the traction by means of a dynamometer (possibly with a recording attachment)
2. measurement of the cable temperature prior to installation.

Cable Bedding

Bedding of the cables needs great care. As a general rule, bedding in sand is recommended; it is not advisable to bed non-armoured cables in stony ground. Particular care must be taken when filling the cable trench so that no damage is caused to the cables (pick-axe blows, spade cuts).

Permissible Temperature Ranges for Installation

Type of insulation	Temperature range $^\circ\text{C}$
PVC insulation, PVC sheath	- 5 to +50
Teflon insulation, teflon sheath	-20 to +50
Silicone rubber insulation, silicone sheath	-15 to +50
Silicone rubber insulation, fibreglass braid	-15 to +50

Extension and Compensating Cables**Delivery Program**

Basically any type of cable can be supplied. However, there are three groups of compensating cables:

- Standard**
(Catalog numbers printed in bold)
The commonly used designs. Delivery at short notice, normally ex stock. No minimum quantity required.
- Extended Standard**
(Catalog numbers printed normally)
Not always available ex stock.
Delivery time and minimum quantity upon request.
- Special Manufacture**
Can be offered for special applications on request. However, the following information is necessary in order to deal with an inquiry:
 - Description of the measuring problem and conditions of installation
 - Indication of standards and tolerances
 - Indication of the order number, if such a special manufacture has previously been purchased from us

Technical Terms of Delivery**Delivery Lengths**

Depending on their diameter, cables are delivered either in 100-m coils or on cable drums. Stock items are 100-m coils and 500-m and 1000-m drums. Bigger lengths and also large quantities in intermediate lengths normally cannot be delivered ex stock.

Extra Charges for small Quantities and minimum Quantities per Order:

Cables of special manufacture and cables in the extended standard programme are subject to a minimum order value for each type, and an extra charge is made for small quantities. For large orders the delivery of single items in small quantities at no extra cost is possible subject to prior agreement. Minimum quantities per order and extra charges for small quantities are applied separately for each type.

It is not possible to summarize the quantities of different types to save the extra charge for small quantities.

Fixed Lengths

Fixed lengths, i.e. lengths specified by order, can be supplied up to 1000 m.

A fixed length is considered to have been supplied as per order if the length does not deviate from the length ordered by more than $\pm 10\%$.

For the enclosure of short lengths, the following rules apply, whereby the individual short lengths are at least 20 m.

a) Cables up to 4 cores
For items of under 10 lengths, a maximum of one length may comprise partial lengths. For items with 10 or more lengths, up to 15% of the ordered quantity may comprise partial lengths.

b) Cables with more than 10 cores
For ordered quantities of up to and including 5 lengths, a maximum of one length may comprise partial lengths. For items of 6 up to and including 10 lengths, a maximum of 2 lengths may comprise partial lengths. For items of more than 10 lengths, up to 20% of the ordered quantity may comprise partial lengths.

Fitting Lengths

Partial lengths and short lengths are excluded from orders of fitting lengths. However, a 20% surcharge on the agreed price is charged for supplying fitting lengths. Fitting lengths which exceed the lengths stated in the section "Fixed Lengths" are subject to special agreement.

Ordering

Cables are ordered by quoting our 7-digit product number.

The compensating cables in our catalogue with their corresponding product numbers are according to the DIN and DIN IEC standard with reference to the EMF, tolerances and colour codes.

Cables with other tolerances and codes are special manufactures (see left column).

Minimum Order Value

The minimum order value is DEM 300.00/Euro 150.00. For order values less than DEM 300.00/Euro 150.00 and quantities less than one production length, a surcharge of 25 % is added.

Extension and Compensating Cables

Fibreglass-insulated Cables

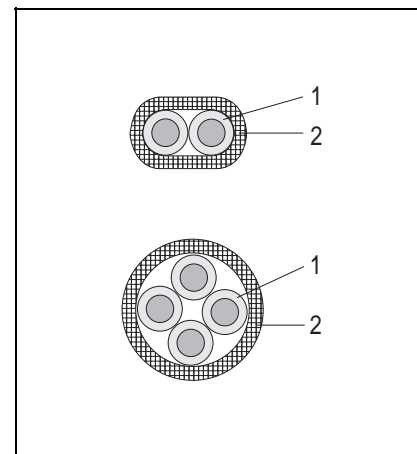
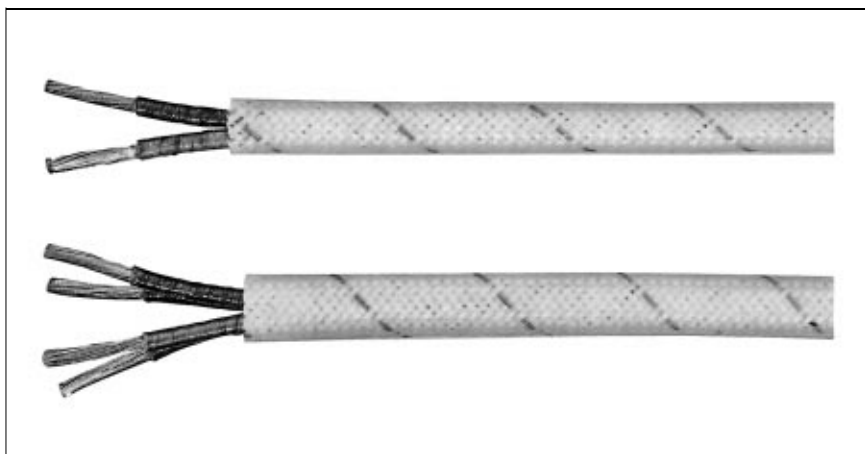

Technical Data

Temperature limit of the insulation up to + 400 °C

Application

In dry rooms;	
light mechanical duty	
electromagnetic disturbances	-
radioactivity	+
mineral oil	○
weak alkaline solutions	-
weak acids	-
benzene	○
gasoline	○
steam	-
humid rooms	○
dry rooms	+
permanent installation	+
mobile installation	○

Insulation Design

1. Fibreglass wrap (GL)
2. Fibreglass braid (GL)

2 cores laid parallel
4 cores twisted

- + = suitable
- = partially suitable
- = not suitable

Type GLGL oval											
No. of cores	Core Ø	Outer Ø approx.	Weight approx.	Type: Standard:	U DIN 43714	TX DIN 43722	L DIN 43714	JX DIN 43722	KCA DIN 43722	RC/SC DIN 43722	BC DIN 43722
2	1.50 mm ² stranded	5.0 x 3.0 mm	0.030 kg/m	Cat.No. Prod. No.	85142111	85142116	7960072 85242111	7961494 85242116	7960198 85742116	7960243 85542116	7960254 85642111
2	1.38 mm solid	2.3 x 4.1 mm	0.030 kg/m	Cat. No. Prod. No.	85145111	85145116	85245111	85245116	85745116	85545116	85645111
Type GLGL											
No. of cores	Core Ø	Outer Ø approx.	Weight approx.	Type: Standard:	U DIN 43714	TX DIN 43722	L DIN 43714	JX DIN 43722	KCA DIN 43722	RC/SC DIN 43722	BC DIN 43722
4	1.50 mm ² stranded	5.3 mm	0.085 kg/m	Cat. No. Prod. No.	85142211	85142216	85242211	85242216	85742216	85542216	85642211
4	1.38 mm solid	4.8 mm	0.085 kg/m	Cat. No. Prod. No.	85145211	85145216	85245211	85245216	85745216	85545216	85645211

Extension and Compensating Cables

Fibreglass-insulated Cables

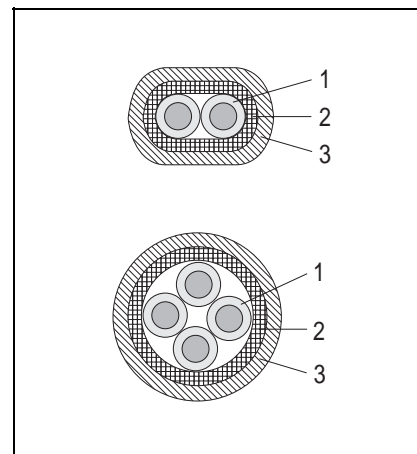
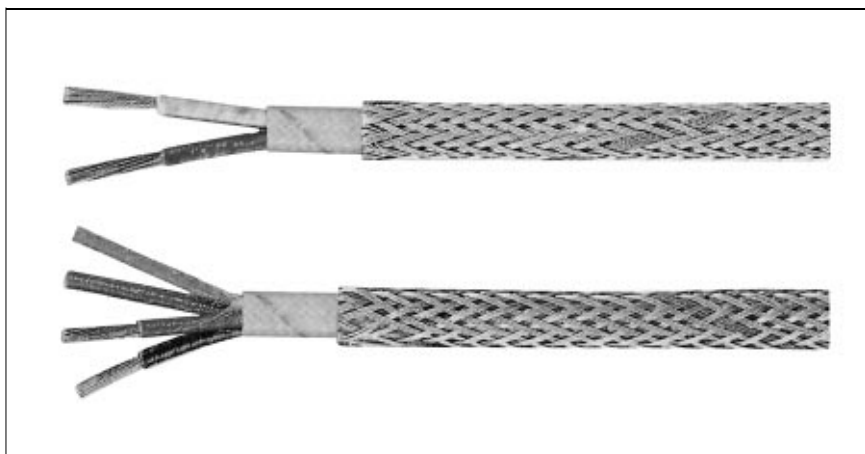

Technical Data

Temperature limit of the insulation up to + 400 °C

Application

In dry rooms;
heavy mechanical duty

electromagnetic disturbances	-
radioactivity	+
mineral oil	○
weak alkaline solutions	-
weak acids	-
benzene	○
gasoline	○
steam	-
humid rooms	○
dry rooms	+
permanent installation	+
mobile installation	○

Insulation Design

1. Fibreglass wrap (GL)
2. Fibreglass braid (GL)
3. Galvanized steel wire braid (P)

2 cores laid parallel
4 cores twisted

- + = suitable
○ = partially suitable
- = not suitable

Type GLGLP oval											
No. of cores	Core Ø	Outer Ø approx.	Weight approx.	Type: Standard:	U DIN 43714	TX DIN 43722	L DIN 43714	JX DIN 43722	KCA DIN 43722	RC/SC DIN 43722	BC DIN 43722
2	1.50 mm ² stranded	3.5 x 5.5 mm	0.055 kg/m	Cat. No. Prod. No.	85142121	7962371 85142126	7960074 85242121	7960075 85242126	7960200 85742126	7960244 85542126	7960255 85642121
2	1.00 mm ² stranded	3.2 x 5.1 mm	0.046 kg/m	Cat. No. Prod. No.				7963269 85241126			
2	1.38 mm ² solid	3.3 x 5.1 mm	0.055 kg/m	Cat. No. Prod. No.	85145121	85145126	85245121	85245126	85745126	85545126	85645121
Type GLGLP											
No. of cores	Core Ø	Outer Ø approx.	Weight approx.	Type: Standard:	U DIN 43714	TX DIN 43722	L DIN 43714	JX DIN 43722	KCA DIN 43722	RC/SC DIN 43722	BC DIN 43722
2	0.22 mm ² stranded	3.6 mm	0.020 kg/m	Cat. No. Prod. No.	85140111	85140116	7960067 85240111	7960068 85240116	7960196 85740116	85540116	85640111
4	0.22 mm ² stranded	4.3 mm	0.040 kg/m	Cat. No. Prod. No.	85146141	85146146	7960069 85246141	7960070 85246146	7960197 85746146	85546146	85646141
2	0.75 mm ² stranded	4.3 mm	0.040 kg/m	Cat. No. Prod. No.	85146141	85146146	7960084 85246141	7960085 85246146	7960203 85746146	7960246 85546146	85646141
4	0.75 mm ² stranded	4.7 mm	0.070 kg/m	Cat. No. Prod. No.	85146241	85146246	7960086 85246241		7960216 85746246	85546246	85646241

Extension and Compensating Cables

PVC-insulated Cables

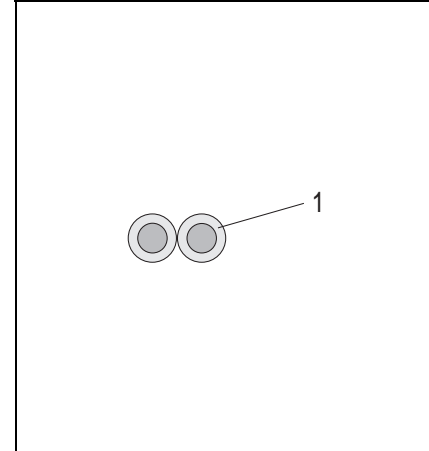
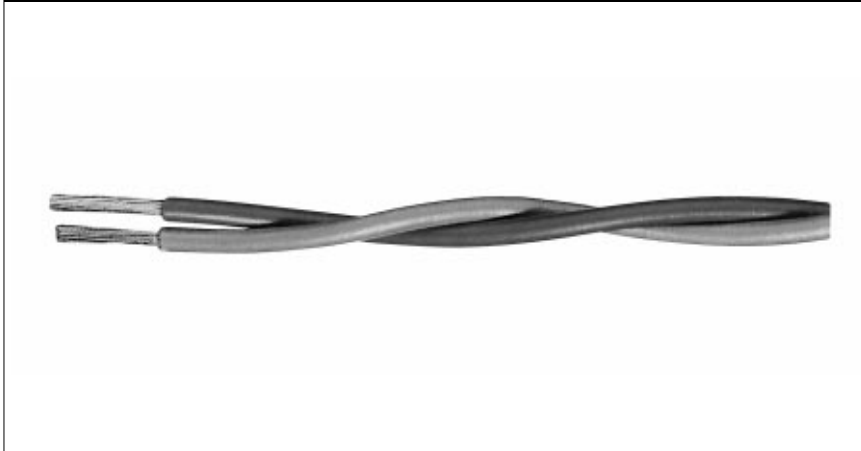

Technical Data

Temperature limit of the insulation
from - 10 °C to + 105 °C

Application

Humid rooms;	
light mechanical duty	
electromagnetic disturbances	-
radioactivity	○
mineral oil	○
weak alkaline solutions	+
weak acids	+
benzene	-
gasoline	+
steam	+
humid rooms	+
dry rooms	+
permanent installation	+
mobile installation	○

Insulation Design

1. PVC insulation (J)

Cores twisted

+ = suitable
○ = partially suitable
- = not suitable

Type J twisted											
No. of cores	Core Ø	Outer Ø approx.	Weight approx.	Type: Standard:	U DIN 43714	TX DIN 43722	L DIN 43714	JX DIN 43722	KCA DIN 43722	RC/SC DIN 43722	BC DIN 43722
2	1.50 mm ² Stranded	5.2 mm	0.055 kg/m	Cat. No.	85112101	85112106	7960022 85212101	85212106	7960164 85712106	7960250 85512106	85612101
2	1.38 mm Solid	4.8 mm	0.055 kg/m	Cat. No.	85115101	85115106	85215101	85215106	85715106	85515106	85615101
Type J single core											
Positive leg											
No. of cores	Core Ø	Outer Ø approx.	Weight approx.	Type: Standard:	U DIN 43714	TX DIN 43722	L DIN 43714	JX DIN 43722	KCA DIN 43722	RC/SC DIN 43722	BC DIN 43722
1	0.75 mm ² Stranded	1.1 mm	0.004 kg/m	Cat. No.	85116011	85116016	7961482 85216011	85216016	85716016	85516016	85616011
Negative leg											
No. of cores	Core Ø	Outer Ø approx.	Weight approx.	Type: Standard:	U DIN 43714	TX DIN 43722	L DIN 43714	JX DIN 43722	KCA DIN 43722	RC/SC DIN 43722	BC DIN 43722
1	0.75 mm ² Stranded	1.1 mm	0.004 kg/m	Cat. No.	85116021	85116026	7961483 85216021	85216026	85716026	85516026	85616021

Extension and Compensating Cables

PVC-insulated Cables

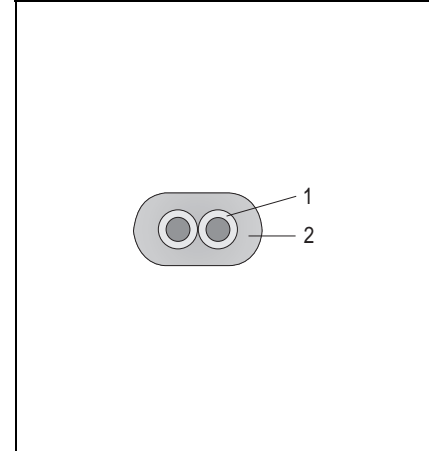

Technical Data

Temperature limit of the insulation
from - 10 °C to + 105 °C

Application

Humid rooms;
medium mechanical duty

electromagnetic disturbances	-
radioactivity	○
mineral oil	○
weak alkaline solutions	+
weak acids	+
benzene	-
gasoline	+
steam	+
humid rooms	+
dry rooms	+
permanent installation	+
mobile installation	○

Insulation Design

- 1. PVC insulation (J)
- 2. PVC sheath (J)

Cores laid parallel

- + = suitable
- = partially suitable
- = not suitable

Type JJ oval											
No. of cores	Core Ø	Outer Ø approx.	Weight approx.	Type: Standard:	U DIN 43714	TX DIN 43722	L DIN 43714	JX DIN 43722	KCA DIN 43722	RC/SC DIN 43722	BC DIN 43722
2	1.50 mm ² Stranded	4.2 x 6.8 mm	0.051 kg/m	Cat. No.	7961431	7960002	7960024	7960025	7960158	7960225	7960251
				Prod. No.	85112121	85112126	85212121	85212126	85712126	85512126	85612121
2	1.38 mm Solid	3.9 x 6.5 mm	0.044 kg/m	Cat. No.			7960040		7960202	7960245	
				Prod. No.	85115121	85115126	85215121	85215126	85715126	85515126	85615121

Extension and Compensating Cables

PVC-insulated Cables

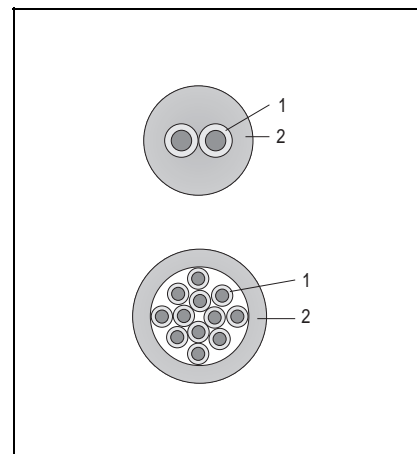
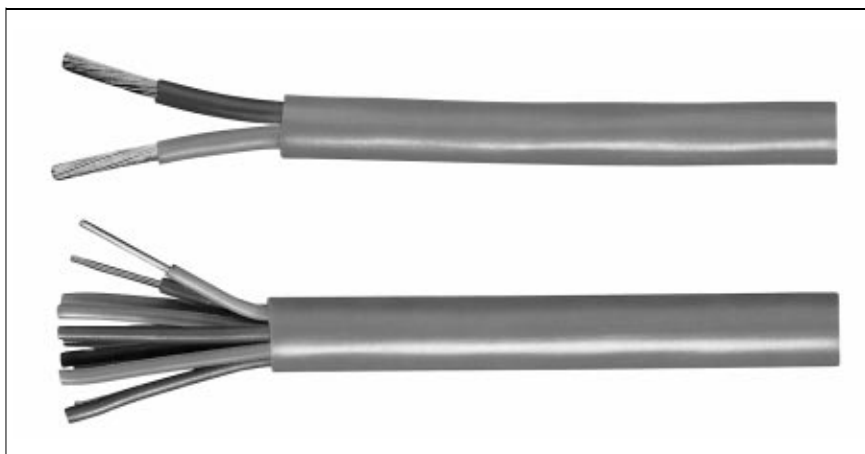

Technical Data

Temperature limit of the insulation	
JJ	- 10 °C to + 105 °C
YY	- 10 °C to + 70 °C

Application

Humid rooms;	
medium mechanical duty	
electromagnetic disturbances	-
radioactivity	○
mineral oil	○
weak alkaline solutions	+
weak acids	+
benzene	-
gasoline	+
steam	+
humid rooms	+
dry rooms	+
permanent installation	+
mobile installation	○

Insulation Design

1. PVC insulation (J/Y)
2. PVC sheath (J/Y)

Cores twisted

- + = suitable
- = partially suitable
- = not suitable

Type JJ											
No. of cores	Core Ø	Outer Ø approx.	Weight approx.	Type: Standard:	U DIN 43714	TX DIN 43722	L DIN 43714	JX DIN 43722	KCA DIN 43722	RC/SC DIN 43722	NC DIN 43722
2	0.22 mm ² Stranded	3.6 mm	0.035 kg/m	Cat. No. Prod. No.	7960001 85110111	85110116	7960016 85210111	7960017 85210116	7960153 85710116	7960222 85510116	7960256 85410001
4	0.22 mm ² Stranded	4.1 mm	0.050 kg/m	Cat. No. Prod. No.	85110201	85110206	7960020 85210201	85210206	7960155 85710206	85510206	
2	1.50 mm ² Stranded	7.3 mm	0.075 kg/m	Cat. No. Prod. No.	85112111	85112116	7960023 85212111	85212116	7960157 85712116	7961966 85512116	
4	1.50 mm ² Stranded	7.8 mm	0.120 kg/m	Cat. No. Prod. No.	85112201	85112206	7960029 85212201	7961479 85212206	7960161 85712206	85512206	
2	1.38 mm Solid	6.4 mm	0.070 kg/m	Cat. No. Prod. No.	85115111	85115116	7960039 85215111	7961480 85215116	7960201 85715116	85515116	
4	1.38 mm Solid	7.4 mm	0.115 kg/m	Cat. No. Prod. No.	85115201	85115206	7961481 85215201	85215206	85715206	85515206	
Type YY											
No. of cores	Core Ø	Outer Ø approx.	Weight approx.	Type: Standard:	U DIN 43714	TX DIN 43722	L DIN 43714	JX DIN 43722	KCA DIN 43722	RC/SC DIN 43722	BC DIN 43722
12	0.80 mm Solid	8.2 mm	0.150 kg/m	Cat. No. Prod. No.	85113301	85113306	7960033 85213301	85213306	7960165 85713306	85513306	85613301
24	0.80 mm Solid	11.6 mm	0.285 kg/m	Cat. No. Prod. No.	85113401	85113406	7960036 85213401	85213406	7960169 85713406	85513406	85613401

Extension and Compensating Cables

PVC insulated Cables

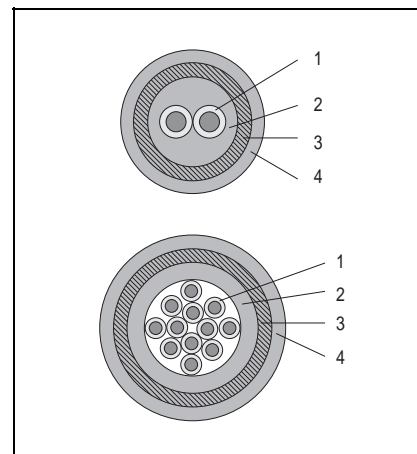
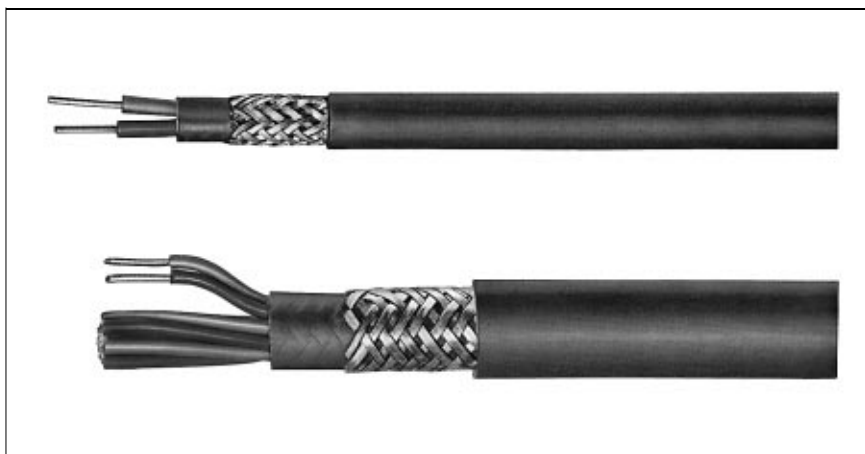

Technical Data

Temperature limit of the insulation	
JJPJ	- 10 °C to + 105 °C
YYPY	- 10 °C to + 70 °C

Application

Humid rooms;	
heavy mechanical duty	
electromagnetic disturbances	○
radioactivity	○
mineral oil	○
weal alkaline solutions	+
weak acids	+
gasoline	-
benzene	+
steam	+
humid rooms	+
dry rooms	+
permanent installation	+
mobile installation	○

Insulation design

1. PVC insulation (J/Y)
2. PVC inner sheath (J/Y)
3. Galvanized steel wire braid (P)
4. PVC outer sheath (J/Y)

Cores twisted

- + = suitable
- = partially suitable
- = not suitable

Type JJPJ											
No. of cores	Core Ø	Outer Ø approx.	Weight approx.	Type: Standard:	U DIN 43714	TX DIN 43722	L DIN 43714	JX DIN 43722	KCA DIN 43722	RC/SC DIN 43722	BC DIN 43722
2	0.22 mm ² Stranded	6.2 mm	0.100 kg/m	Cat. No. Prod. No.	85110141	85110146	85210141	85210146	85710146	85510146	85610141
4	0.22 mm ² Stranded	6.7 mm	0.120 kg/m	Cat. No. Prod. No.	85110221	85110226	85210221	85210226	85710226	85510226	85610221
2	1.50 mm ² Stranded	9.8 mm	0.150 kg/m	Cat. No. Prod. No.	85112141	85112146	7960026 85212141	7961478 85212146	7960159 85712146	7960226 85512146	85612141
4	1.50 mm ² Stranded	11.2 mm	0.200 kg/m	Cat. No. Prod. No.	85112221	85112226	7960030 85212221	85212226	7960162 85712226	85512226	85612221
2	1.38 mm Solid	8.2 mm	0.140 kg/m	Cat. No. Prod. No.	85115141	85115146	7960041 85215141	85215146	7960174 85715146	7961556 85515146	85615141
4	1.38 mm Solid	10.3 mm	0.180 kg/m	Cat. No. Prod. No.	85115221	85115226	7960043 85215221	85215226	7960173 85715226	85515226	85615221

Type YYPY											
No. of cores	Core Ø	Outer Ø approx.	Weight approx.	Type: Standard:	U DIN 43714	TX DIN 43722	L DIN 43714	JX DIN 43722	KCA DIN 43722	RC/SC DIN 43722	BC DIN 43722
12	0.80 mm Solid	10.9 mm	0.280 kg/m	Cat. No. Prod. No.	85113341	85113346	7960035 85213341	85213346	7960167 85713346	85513346	85613341
24	0.80 mm Solid	14.6 mm	0.470 kg/m	Cat. No. Prod. No.	85113441	85113446	7960038 85213441	85213446	7960171 85713446	85513446	85613441

Extension and Compensating Cables

PVC- insulated Cables

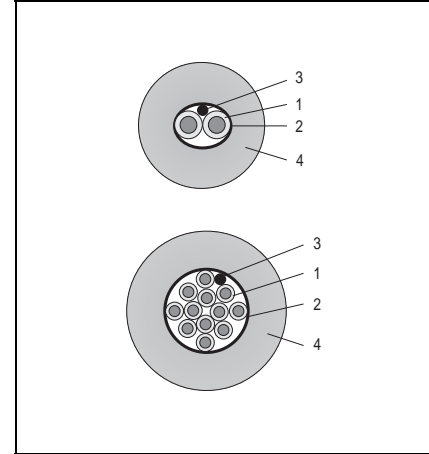
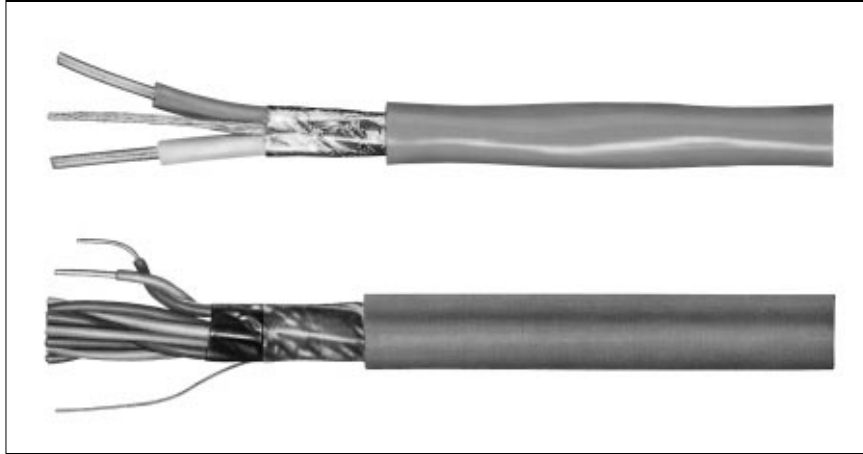

Technical Data

Temperature limit of the insulation	
JFJ	- 10 °C to + 105 °C
YFY	- 10 °C to + 70 °C

Noise reduction:
electric fields approx. 70 dB
magnetic fields approx. 40 dB

Application

Compensating cable suitable for computers	
electromagnetic disturbances	+
radioactivity	○
mineral oil	○
weak alkaline solutions	+
weak acids	+
benzene	-
gasoline	+
steam	+
humid rooms	+
dry rooms	+
permanent installation	+
mobile installation	○

Insulation Design

1. PVC insulation (J/Y)
2. Plastic-laminated aluminium foil (F)
3. Copper drain wire
4. PVC sheath (J/Y)

Cores twisted

- + = suitable
- = partially suitable
- = not suitable

Type JFJ												
No. of cores	Core Ø	Outer Ø approx.	Weight approx.	Type: Standard:	TX DIN 43722	L DIN 43714	JX DIN 43722	KCA DIN 43722	RC/SC DIN 43722	Wo3%Re Wo25%Re	Wo5%Re Wo26%Re	
2	0.22 mm ² Stranded	4.4 mm	0.045 kg/m	Cat. No. Prod. No.		7960018 85210151	7960019 85210156	7960154 85710156	7960223 85510156			
4	0.22 mm ² Stranded	5.4 mm	0.060 kg/m	Cat. No. Prod. No.		7960021 85210231	7961476 85210236	7960156 85710236	85510236			
2	0.75 mm ² Stranded	6.6 mm	0.060 kg/m	Cat. No. Prod. No.		7960045 85216151	7963270 85216156	7960213 85716156	7960230 85516156	7961570 85916159		
4	0.75 mm ² Stranded	8.8 mm	0.085 kg/m	Cat. No. Prod. No.		85116236	85216231	85216236	7960179 85716236	85516236		
2	1.50 mm ² Stranded	7.3 mm	0.085 kg/m	Cat. No. Prod. No.		85112156	7960027 85212151	7960028 85212156	7960160 85712156	7960227 85512156	7960259 85912159	7960260 85912169
4	1.50 mm ² Stranded	11.0 mm	0.130 kg/m	Cat. No. Prod. No.		85112236	7960031 85212231	7962211 85212236	7960163 85712236	85512236		
2	1.38 mm Solid	7.0 mm	0.080 kg/m	Cat. No. Prod. No.		85215156	7960042 85215151	85215156	7960175 85715156	7961557 85515156		
Type YFY												
No. of cores	Core Ø	Outer Ø approx.	Weight approx.	Type: Standard:	TX DIN 43722	L DIN 43714	JX DIN 43722	KCA DIN 43722	RC/SC DIN 43722	UX DIN 43714	BC DIN 43722	
12	0.80 mm Solid	7.3 mm	0.200 kg/m	Cat. No. Prod. No.		7960034 85213311	7962216 85213316	7960166 85713316	85513316	85113311	7961903 85613311	
24	0.80 mm Solid	14.0 mm	0.300 kg/m	Cat. No. Prod. No.		7960037 85213411	7962222 85213416	7960170 85713416	85513416	85113411	85613411	

Extension and Compensating Cables

PVC-insulated Cables

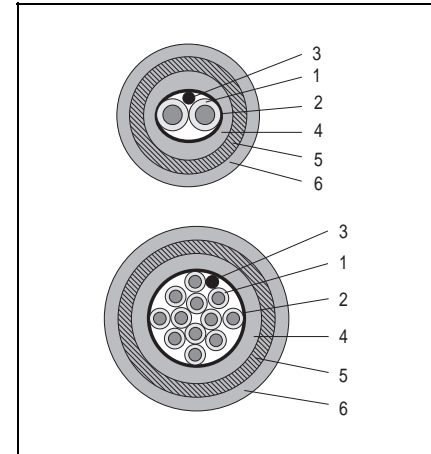
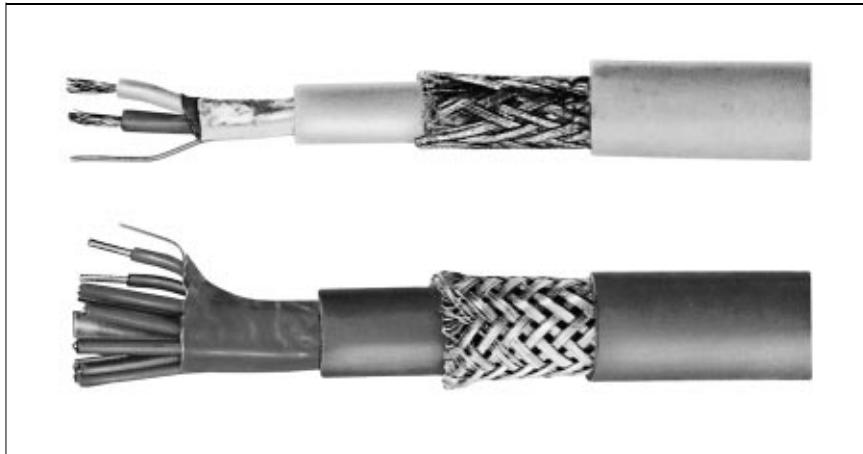

Technical Data

Temperature limit of the insulation	
JFJPJ	- 10 °C to + 105 °C
YFYYPY	- 10 °C to + 70 °C

Noise reduction:
electric fields approx. 70 dB
magnetic fields approx. 40 dB

Application

Compensating cable suitable for computers; high mechanical duty

electromagnetic disturbances	○
radioactivity	○
mineral oil	○
weak alkaline solutions	+
weak acids	+
benzene	-
gasoline	+
steam	+
humid rooms	+
dry rooms	+
permanent installation	+
mobile installation	○

Insulation Design

1. PVC insulation (J/Y)
2. Plastic-laminated aluminium foil (F)
3. Copper drain wire
4. PVC inner sheath (J/Y)
5. Galvanized steel wire braid (P)
6. PVC outer sheath (Y/J)

Cores twisted

- + = suitable
- = partially suitable
- = not suitable

Type JFJPJ											
No. of cores	Core Ø	Outer Ø approx.	Weight approx.	Type: Standard:	U DIN 43714	TX DIN 43722	L DIN 43714	JX DIN 43722	KCA DIN 43722	RC/SC DIN 43722	BC DIN 43722
2	0.22 mm ² Stranded	6.6 mm	0.110 kg/m	Cat. No. Prod. No.	85110171	85110176	85210171	85210176	85710176	85510176	85610171
4	0.22 mm ² Stranded	7.7 mm	0.180 kg/m	Cat. No. Prod. No.	85110251	85110256	85210251	85210256	85710256	85510256	85610251
2	1.50 mm ² Stranded	9.8 mm	0.160 kg/m	Cat. No. Prod. No.	85112171	85112176	85212171	85212176	85712176	85512176	85612171
4	1.50 mm ² Stranded	13.4 mm	0.220 kg/m	Cat. No. Prod. No.	85112251	85112256	85212251	85212256	85712256	85512256	85612251
2	1.38 mm Solid	9.4 mm	0.150 kg/m	Cat. No. Prod. No.	85115171	85115176	85215171	85215176	7960176 85715176	85515176	85615171
4	1.38 mm Solid	12.8 mm	0.200 kg/m	Cat. No. Prod. No.	85115251	85115256	85215251	85215256	85715256	85515256	85615251

Type YFYYPY											
No. of cores	Core Ø	Outer Ø approx.	Weight approx.	Type: Standard:	U DIN 43714	TX DIN 43722	L DIN 43714	JX DIN 43722	KCA DIN 43722	RC/SC DIN 43722	BC DIN 43722
12	0.80 mm Solid	13.2 mm	0.325 kg/m	Cat. No. Prod. No.	85113381	85113386	85213381	85213386	7960168 85713386	85513386	85613381
24	0.80 mm Solid	16.6 mm	0.480 kg/m	Cat. No. Prod. No.	85113481	85113486	85213481	85213486	7960172 85713486	85513486	85613481

Extension and Compensating Cables

Silicone rubber-insulated Cables

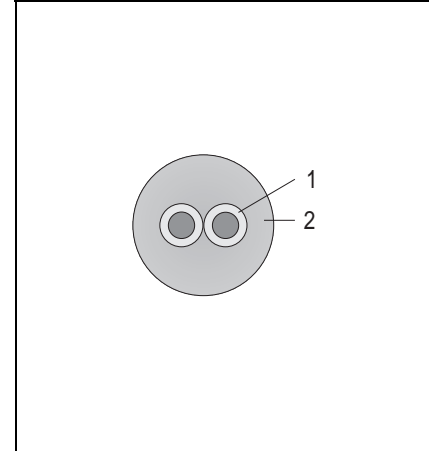

Technical Data

Temperature limit of the insulation
from - 60 °C to + 200 °C

Application

In humid rooms at high temperatures
with medium mechanical duty

electromagnetic disturbances	-
radioactivity	-
mineral oil	○
weak alkaline solutions	+
weak acids	+
benzene	-
gasoline	-
steam	○
humid rooms	+
dry rooms	+
permanent installation	○
mobile installation	+

Insulation Design

1. Silicone rubber insulation (SL)
2. Silicone rubber sheath (SL)

Cores twisted

- + = suitable
- = partially suitable
- = not suitable

Type SLSL											
No. of cores	Core Ø	Outer Ø approx.	Weight approx.	Type: Standard:	U DIN 43714	TX DIN 43722	L DIN 43714	JX DIN 43722	KCA DIN 43722	RC/SC DIN 43722	NC DIN 43722
2	0.22 mm ² Stranded	3.8 mm	0.020 kg/m	Cat. No. Prod. No.	85120111	85120116	7960046 85220111	7960050 85220116	7960180 85720116	7960231 85520116	7960258 85410003
4	0.22 mm ² Stranded	4.3 mm	0.025 kg/m	Cat. No. Prod. No.	85120201	85120206	85220201	85220206	7960181 85720206	85520206	85410201
2	1.50 mm ² Stranded	7.2 mm	0.110 kg/m	Cat. No. Prod. No.	85122111	85122116	7960061 85222111	85222116	7960192 85722116	85522116	85412111

Extension and Compensating Cables

Silicone rubber-insulated Cables

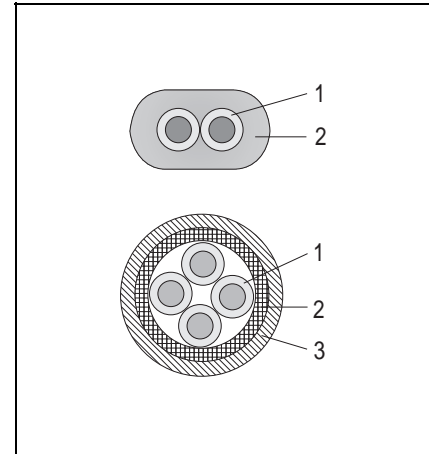
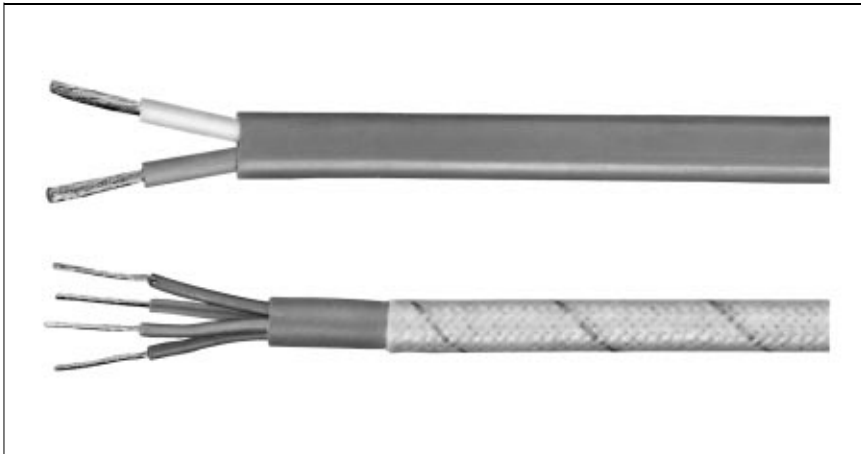

Technical Data

Temperature limit of the insulation
from - 60 °C to + 200 °C

Application

In humid rooms at high temperatures
with medium mechanical duty

electromagnetic disturbances	-
radioactivity	+
mineral oil	○
weak alkaline solutions	+
weak acids	+
benzene	-
gasoline	-
steam	○
humid rooms	+
dry rooms	+
permanent installation	○
mobile installation	+

Insulation Design

1. Silicone rubber insulation (SL)
2. Silicone rubber sheath (SL)
3. Fibreglass braid (GL)

2 cores laid parallel
4 cores twisted

+ = suitable
○ = partially suitable
- = not suitable

Type SLSL oval											
No. of cores	Core Ø	Outer Ø approx.	Weight approx.	Type: Standard:	U DIN 43714	TX DIN 43722	L DIN 43714	JX DIN 43722	KCA DIN 43722	RC/SC DIN 43722	BC DIN 43722
2	1.50 mm ² Stranded	4.3 x 7.1 mm	0.100 kg/m	Cat. No. Prod. No.	85122101	85122106	7960052 85222101	7960053 85222106	7960185 85722106	7960235 85522106	85622101
Type SLSLGL											
No. of cores	Core Ø	Outer Ø approx.	Weight approx.	Type: Standard:	U DIN 43714	TX DIN 43722	L DIN 43714	JX DIN 43722	KCA DIN 43722	RC/SC DIN 43722	BC DIN 43722
2	0.22 mm ² Stranded	4.7 mm	0.025 kg/m	Cat. No. Prod. No.	85120141	85120146	7960047 85220141	85220146	7960182 85720146	7960232 85520146	7960252 85620141
4	0.22 mm ² Stranded	5.5 mm	0.030 kg/m	Cat. No. Prod. No.	85120241	85120246	7960048 85220241	85220246	7961569 85720246	85520246	85620241

Extension and Compensating Cables

Silicone rubber-insulated Cables

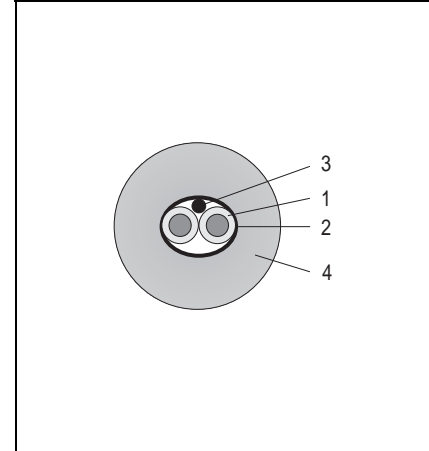

Technical Data

Temperature limit of the insulation
from - 60 °C to + 200 °C

Application

In humid rooms at high temperatures
with light mechanical duty

electromagnetic disturbances	+
radioactivity	+
mineral oil	○
weak alkaline solutions	+
weak acids	+
benzene	-
gasoline	-
steam	○
humid rooms	+
dry rooms	+
permanent installation	○
mobile installation	+

Insulation Design

1. Silicone rubber insulation (SL)
2. Plastic-laminated aluminium foil (F)
3. Copper drain wire
4. Silicone rubber sheath (SL)

Cores twisted

- + = suitable
- = partially suitable
- = not suitable

Type SLFSL											
No. of cores	Core Ø	Outer Ø approx.	Weight approx.	Type: Standard:	U DIN 43714	TX DIN 43722	L DIN 43714	JX DIN 43722	KCA DIN 43722	RC/SC DIN 43722	BC DIN 43722
2	1.50 mm ² Stranded	7.8 mm	0.100 kg/m	Cat. No. Prod. No.	85122151	85122156	7960055 85222151	7962244 85222156	7960187 85722156	7960237 85522156	85622151

Extension and Compensating Cables

Silicone rubber-insulated Cables

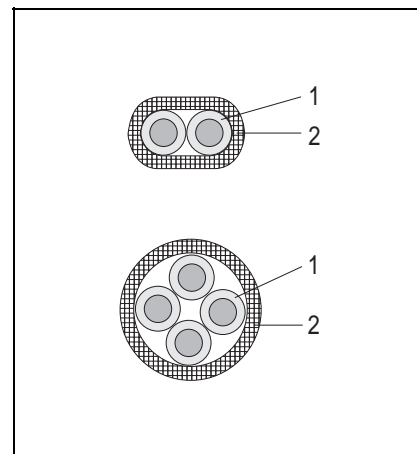
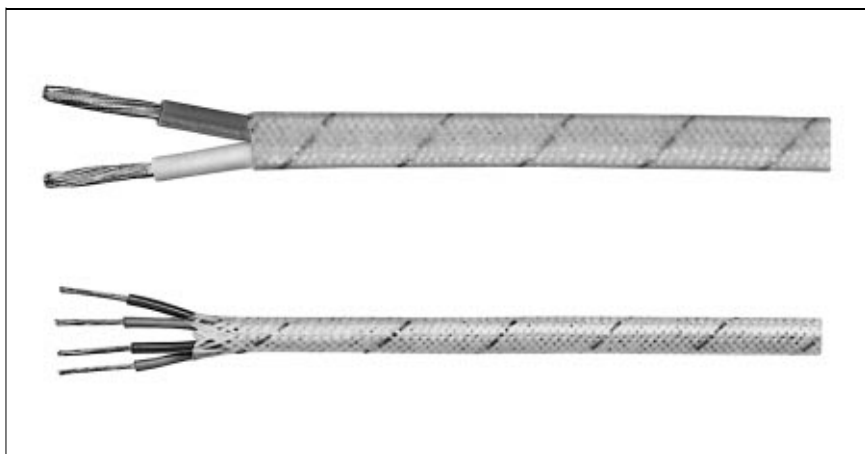

Technical Data

Temperature limit of the insulation
from - 60 °C to + 200 °C

Application

In humid rooms at high temperatures
with light mechanical duty

electromagnetic disturbances	-
radioactivity	+
mineral oil	○
weak alkaline solutions	+
weak acids	+
benzene	-
gasoline	-
steam	○
humid rooms	+
dry rooms	+
permanent installation	+
mobile installation	○

Insulation Design

1. Silicone rubber insulation (SL)
2. Fibreglass braid (GL)

SLGL oval: 2 cores laid parallel
SLGL: cores twisted

- + = suitable
○ = partially suitable
- = not suitable

Type SLGL oval											
No. of cores	Core Ø	Outer Ø approx.	Weight approx.	Type: Standard:	U DIN 43714	TX DIN 43722	L DIN 43714	JX DIN 43722	KCA DIN 43722	RC/SC DIN 43722	BC DIN 43722
2	1.50 mm ² Stranded	3.3 x 6.0 mm	0.055 kg/m	Cat. No. Prod. No.	85122131	85122136	7960054 85222131	7961488 85222136	7960186 85722136	7960236 85522136	7961561 85622131
2	1.38 mm Solid	3.1 x 5.7 mm	0.050 kg/m	Cat. No. Prod. No.	85125131	85225136	7960063 85225131	85225136	7960194 85722136	7960241 85525136	85625131
Type SLGL											
No. of cores	Core Ø	Outer Ø approx.	Weight approx.	Type: Standard:	U DIN 43714	TX DIN 43722	L DIN 43714	JX DIN 43722	KCA DIN 43722	RC/SC DIN 43722	BC DIN 43722
2	1.50 mm ² Stranded	6.1 mm	0.060 kg/m	Cat. No. Prod. No.	85122091	85122096	85222091	85222096	85722096	85522096	85622091
4	1.50 mm ² Stranded	7.2 mm	0.100 kg/m	Cat. No. Prod. No.	85122231	85122236	85222231	85222236	85722236	85522236	85622231
2	1.38 mm Solid	5.7 mm	0.058 kg/m	Cat. No. Prod. No.	85125091	85125096	85225091	85225096	85725096	85525096	85625091
4	1.38 mm Solid	6.8 mm	0.098 kg/m	Cat. No. Prod. No.	85125231	85125236	85225231	85225236	85725236	85525236	85625231

Extension and Compensating Cables

Silicone rubber-insulated Cables

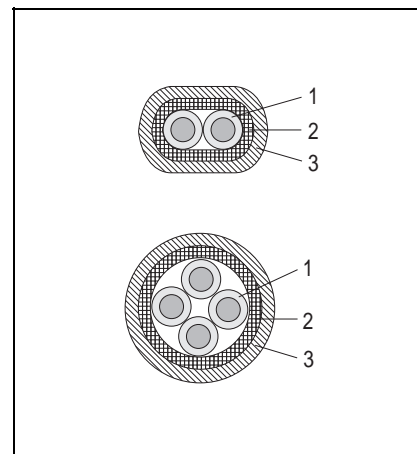
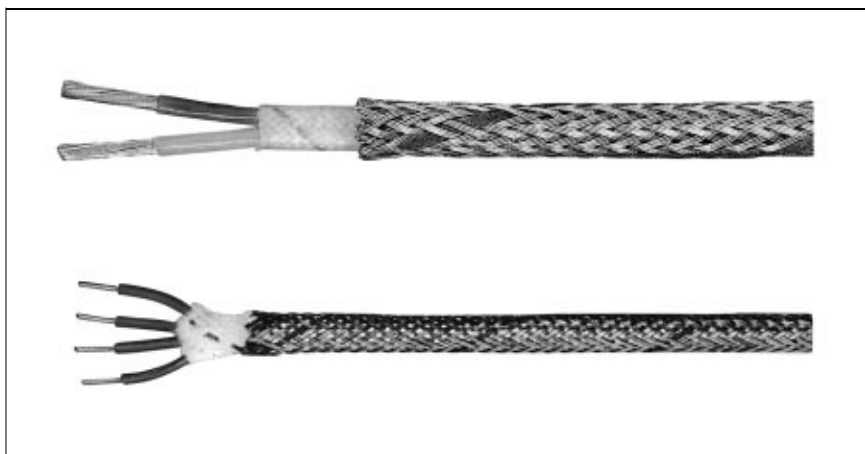

Technical Data

Temperature limit of the insulation
from - 60 °C to + 200 °C

Application

In humid rooms at high temperatures
with heavy mechanical duty

electromagnetic disturbances	○
radioactivity	+
mineral oil	○
weak alkaline solutions	○
weak acids	-
benzene	-
gasoline	-
steam	○
humid rooms	+
dry rooms	+
permanent installation	+
mobile installation	○

Insulation Design

1. Silicone rubber insulation (SL)
2. Fibreglass braid (GL)
3. Galvanized steel wire braid (P)

SLGLP oval: 2 cores laid parallel
SLGLP: cores twisted

- + = suitable
○ = partially suitable
- = not suitable

Type SLGLP oval											
No. of cores	Core Ø	Outer Ø approx.	Weight approx.	Type: Standard:	U DIN 43714	TX DIN 43722	L DIN 43714	JX DIN 43722	KCA DIN 43722	RC/SC DIN 43722	BC DIN 43722
2	1.50 mm ² Stranded	4.3 x 6.5 mm	0.085 kg/m	Cat. No. Prod. No.	85122171	85122176	7960056 85222171	7960057 85222176	7960188 85722176	7960238 85522176	7960253 85622171
2	1.38 mm Solid	3.1 x 5.7 mm	0.080 kg/m	Cat. No. Prod. No.	85125171	85125176	7960064 85225171	85225176	7960195 85725176	7960242 85525176	85625171
Type SLGLP											
No. of cores	Core Ø	Outer Ø approx.	Weight approx.	Type: Standard:	U DIN 43714	TX DIN 43722	L DIN 43714	JX DIN 43722	KCA DIN 43722	RC/SC DIN 43722	BC DIN 43722
2	1.50 mm ² Stranded	7.1 mm	0.090 kg/m	Cat. No. Prod. No.	85122191	85122196	7960058 85222191	85222196	7960189 85722196	7961558 85522196	85622191
4	1.50 mm ² Stranded	8.2 mm	0.130 kg/m	Cat. No. Prod. No.	85122271	85122276	7960049 85222271	85222276	7960190 85722276	7960239 85522276	85622271
2	1.38 mm Solid	6.7 mm	0.088 kg/m	Cat. No. Prod. No.	85125191	85125196	85225191	85225196	85725196	85525196	85625191
4	1.38 mm Solid	7.7 mm	0.128 kg/m	Cat. No. Prod. No.	85125271	85125276	85225271	85225276	85725276	85525276	85625271

Extension and Compensating Cables

Teflon-insulated Cables

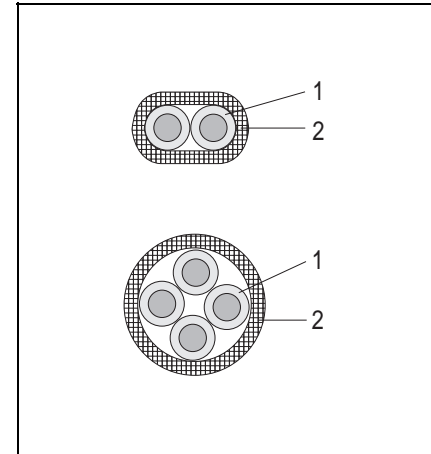
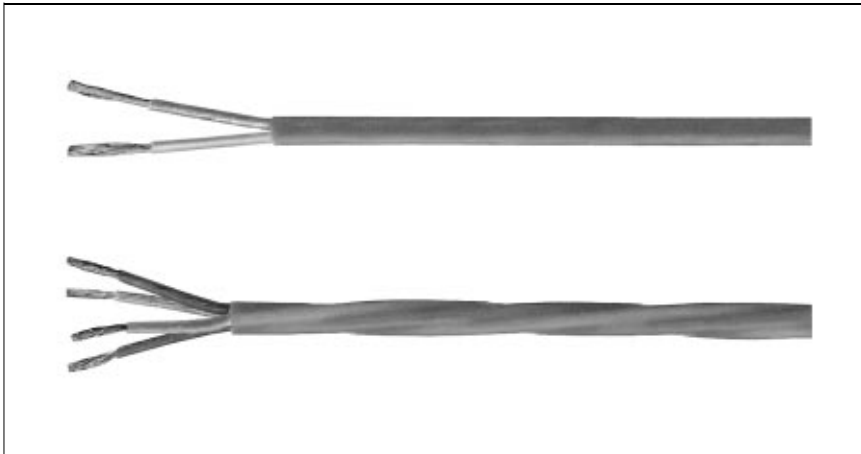

Technical Data

Temperature limit of the insulation
from - 200 °C to + 200 °C

Application

At high temperatures with particular requirements with regard to resistance to chemicals

electromagnetic disturbances	-
radioactivity	-
mineral oil	+
weak alkaline solutions	+
weak acids	+
benzene	+
gasoline	+
steam	+
humid rooms	+
dry rooms	+
permanent installation	+
mobile installation	+

Insulation Design

1. Teflon® FEP insulation (T)
2. Teflon® FEP sheath (T)

- 2 cores laid parallel
- 4 cores twisted

- + = suitable
- = partially suitable
- = not suitable

Type TT oval											
No. of cores	Core Ø	Outer Ø approx.	Weight approx.	Type: Standard:	U DIN 43714	TX DIN 43722	L DIN 43714	JX DIN 43722	KCA DIN 43722	RC/SC DIN 43722	BC DIN 43722
2	0.50 mm ² Stranded	2.0 x 3.5 mm	0.020 kg/m	Cat. No.	85154101	85154106	85254101	85254106	7960215 85754106	85554106	85654101
2	0.75 mm ² Stranded	2.4 x 4.2 mm	0.023 kg/m	Cat. No.	85156101	85156106	7960099 85256101	7960100 85256106	7961563 85756106	7960249 85556106	85656101
Type TT											
No. of cores	Core Ø	Outer Ø approx.	Weight approx.	Type: Standard:	U DIN 43714	TX DIN 43722	L DIN 43714	JX DIN 43722	KCA DIN 43722	RC/SC DIN 43722	BC DIN 43722
4	0.75 mm ² Stranded	5.1 mm	0.038 kg/m	Cat. No.	85156201	85156206	7960101 85256201	7962269 85256206	7960219 85756206	85556206	85656201

Extension and Compensating Cables

Teflon-insulated Cables

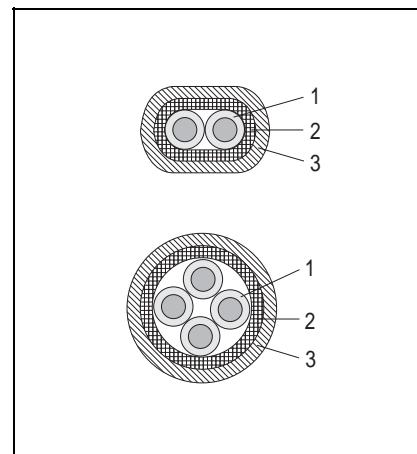
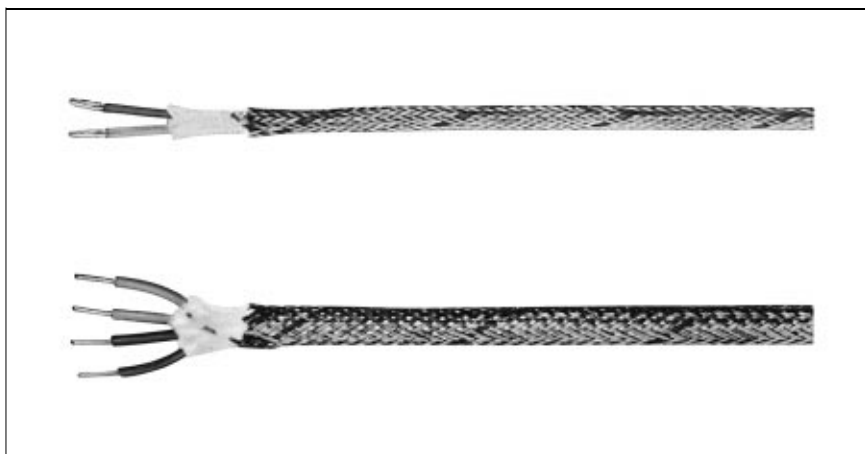

Technical Data

Temperature limit of the insulation
from - 200 °C to + 200 °C

Application

At high temperatures with particular requirements with regard to resistance to chemicals and heavy mechanical duty

electromagnetic disturbances	○
radioactivity	-
mineral oil	+
weak alkaline solutions	+
weak acids	-
benzene	+
gasoline	+
steam	+
humid rooms	+
dry rooms	+
permanent installation	+
mobile installation	○

Insulation Design

1. Teflon® FEP insulation (T)
2. Fibreglass braid (GL)
3. Galvanized steel wire braid (P)

TGLP oval: cores laid parallel
TGLP: cores twisted

- + = suitable
○ = partially suitable
- = not suitable

Type TGLP oval											
No. of cores	Core Ø	Outer Ø approx.	Weight approx.	Type: Standard:	U DIN 43714	TX DIN 43722	L DIN 43714	JX DIN 43722	KCA DIN 43722	RC/SC DIN 43722	BC DIN 43722
2	1.50 mm ² Stranded	5.7 x 3.5 mm	0.045 kg/m	Cat. No. Prod. No.	85152131	85152136	7960092 85252131	85252136	7960209 85752136	85552136	85652131
Type TGLP											
No. of cores	Core Ø	Outer Ø approx.	Weight approx.	Type: Standard:	U DIN 43714	TX DIN 43722	L DIN 43714	JX DIN 43722	KCA DIN 43722	RC/SC DIN 43722	BC DIN 43722
2	0.22 mm ² Stranded	3.5 mm	0.032 kg/m	Cat. No. Prod. No.	85150161	85150166	7961507 85250161	85250166	7960207 85750166	7960247 85550166	85650161
4	0.22 mm ² Stranded	4.0 mm	0.050 kg/m	Cat. No. Prod. No.	85150261	85150266	85250261	85250266	85750266	85550266	85650261
2	1.50 mm ² Stranded	5.7 mm	0.055 kg/m	Cat. No. Prod. No.	85152161	85152166	7960094 85252161	7960095 85252166	7960212 85752166	85552166	85652161
4	1.50 mm ² Stranded	6.8 mm	0.085 kg/m	Cat. No. Prod. No.	85152261	85152266	85252261	85252266	7960214 85752266	85552266	85652261

Extension and Compensating Cables

Teflon-insulated Cables

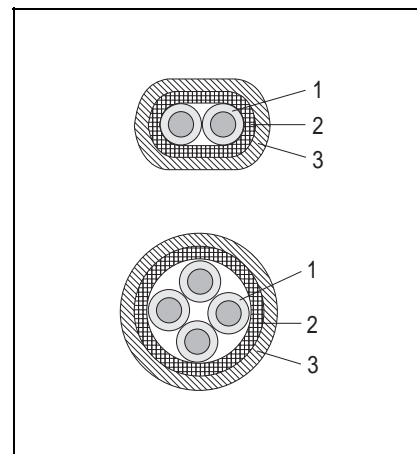
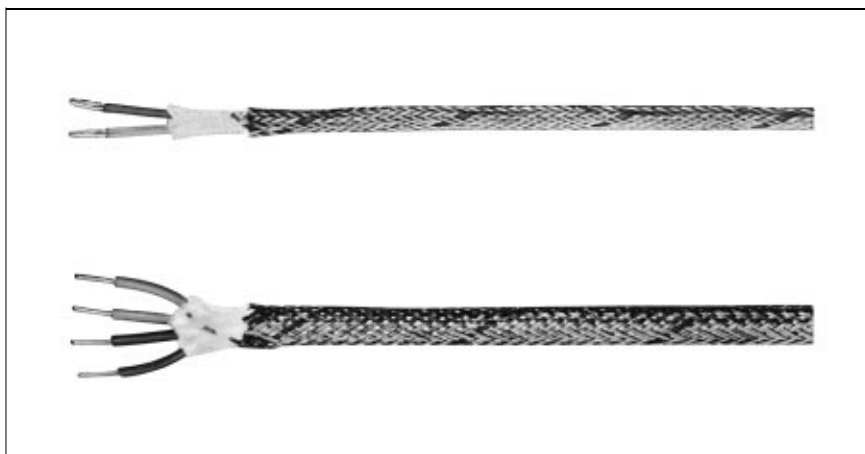

Technical Data

Temperature limit of the insulation
from - 200 °C to + 200 °C

Application

At high temperatures with particular requirements with regard to resistance to chemicals and heavy mechanical duty

electromagnetic disturbances	○
radioactivity	-
mineral oil	+
weak alkaline solutions	+
weak acids	+
benzene	+
gasoline	+
steam	+
humid rooms	+
dry rooms	+
permanent installation	+
mobile installation	○

Insulation Design

1. Teflon® FEP insulation (T)
2. Fibreglass braid (GL)
3. Stainless steel wire braid (V)

TGLV oval: cores laid parallel
TGLV: cores twisted

- + = suitable
○ = partially suitable
- = not suitable

Type TGLV oval											
No. of cores	Core Ø	Outer Ø approx.	Weight approx.	Type: Standard:	U DIN 43714	TX DIN 43722	L DIN 43714	JX DIN 43722	KCA DIN 43722	RC/SC DIN 43722	BC DIN 43722
2	0.22 mm ² Stranded	3.3 x 2.0 mm	0.022 kg/m	Cat. No. Prod. No.	85150141	85150146	7960089 85250141	7963289 85250146	7960206 85750146	85550146	85650141
2	1.50 mm ² Stranded	5.7 x 3.5 mm	0.045 kg/m	Cat. No. Prod. No.	85152141	85152146	7960093 85252141	85252146	7960210 85752146	85552146	85652141
Type TGLV											
No. of cores	Core Ø	Outer Ø approx.	Weight approx.	Type: Standard:	U DIN 43714	TX DIN 43722	L DIN 43714	JX DIN 43722	KCA DIN 43722	RC/SC DIN 43722	BC DIN 43722
4	0.22 mm ² Stranded	3.7 mm	0.040 kg/m	Cat. No. Prod. No.	85150241	85150246	85250241	7961508 85250246	7960208 85750246	85550246	85650241
4	1.50 mm ² Stranded	6.6 mm	0.075 kg/m	Cat. No. Prod. No.	85152241	85152246	85252241	85252246	85752246	85552246	85652241

Extension and Compensating Cables

Teflon-insulated Cables

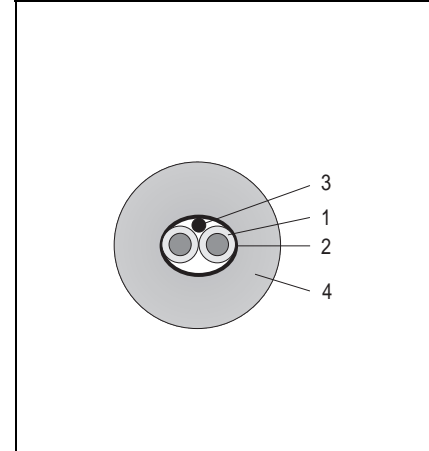
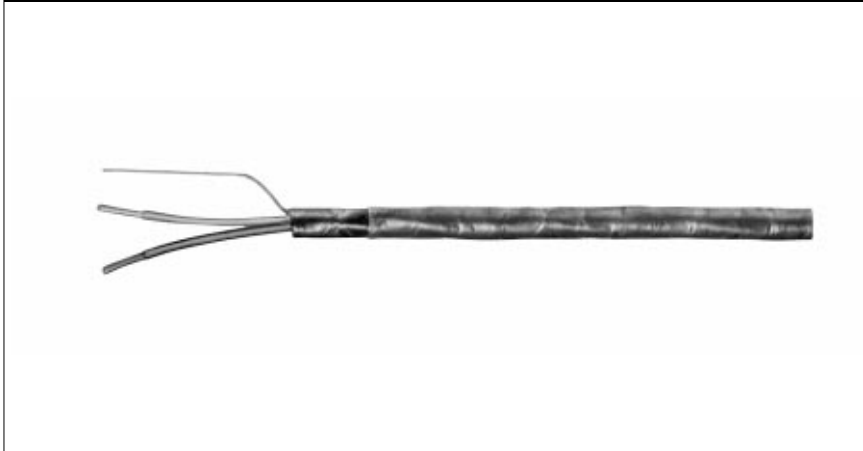

Technical Data

Temperature limit of the insulation
from - 200 °C to + 200 °C

Noise reduction:
electric fields approx. 70 dB
magnetic fields approx. 40 dB

Application

Compensating cable suitable for computers; for high temperatures with particular requirements with regard to chemicals

electromagnetic disturbances	+
radioactivity	-
mineral oil	+
weak alkaline solutions	+
weak acids	+
benzene	+
gasoline	+
steam	+
humid rooms	+
dry rooms	+
permanent installation	+
mobile installation	-

Insulation Design

1. Teflon® FEP insulation (T)
2. Plastic-laminated aluminium foil (F)
3. Copper drain wire
4. Teflon® FEP sheath (T)

Twisted pairs

- + = suitable
- = partially suitable
- = not suitable

Type TFT											
No. of core	Core Ø	Outer Ø approx.	Weight approx.	Type: Standard:	U DIN 43714	TX DIN 43722	L DIN 43714	JX DIN 43722	KCA DIN 43722	RC/SC DIN 43722	BC DIN 43722
2	1.38 mm Solid	4.7 mm	0.045 kg/m	Cat. No. Prod. No.	85155111	85155116	7960098 85255111	7962268 85255116	7960217 85755116	85555116	85655111

Copper Cables

No. of cores	Core size	Core material	Insulation	Outer Ø approx.	Color code: core – sheath	Prod. No.
Type Fibreglass-insulated						
1	0.22 mm ²	Cu nickel-clad 35 %	GL to 500 °C	0.82 mm	natural	7961594
1	0.22 mm ²	Cu nickel-clad 35 %	GL to 500 °C	0.82 mm	red	7963291
1	0.22 mm ²	Cu nickel-clad 35 %	GL with Kapton up to + 500 °C	1.50 mm	natural	7961595
2	0.22 mm ²	Cu nickel-clad 35 %	GL twisted	max. 1.90 mm	natural – natural	7963235
2	0.22 mm ²	Cu nickel-clad 35 %	GLGL	3.80 mm	natural – natural	7961597
2	0.22 mm ²	Cu nickel-plated	GLGL oval	1.60 x 2.70 mm	natural – natural	7961598
2	0.50 mm ²	Cu nickel-clad 35 %	GLGL oval	1.10 x 2.00 mm	natural – natural	7961596
2	0.50 mm ²	Cu nickel-plated	GLGLV	4.00 mm	red/white – white	7961599
4	0.50 mm ²	Cu	GLGLV	3.60 mm	white/white/white/white – braid	7961600
Type PVC-insulated						
2	0.22 mm ²	Cu	JJ	3.20 mm	yellow/violet – black	7960282
4	0.22 mm ²	Cu	JJ	5.50 mm	red/white – black	7960296
6	0.22 mm ²	Cu	JJ	5.40 mm	2red/1white/2black/1yellow – grey	7960304
8	0.25 mm ²	Cu	LIYCY	6.20 mm	yellow/green/brown/grey/pink/blue/red/white – natural	7961581
Type Silicone rubber-insulated						
1	0.50 mm ²	Cu	SL	2.10 mm	green	7961589
1	0.50 mm ²	Cu	SL	2.10 mm	red	7961590
2	0.25 mm ²	Cu	SLSLCuSL	5.00 mm	white/brown – reddishbrown	7961587
2	0.25 mm ²	Cu tinned	SLSL	3.40 mm	white/red – black	7960275
2	0.35 mm ²	Cu nickel plated	SLSL	5.00 mm	brown/white – brown	7960276
2	0.75 mm ²	Cu tinned	SLSL	6.40 mm	white/white – brown	7960280
2	1.00 mm ²	Cu	SLSL	7.00 mm	white/white – red	7960284
3	0.25 mm ²	Cu tinned	SLSL	4.80 mm	green/brown/white – black	7960281
4	0.25 mm ²	Cu tinned	SLSL	5.00 mm	red/red/white/white – reddishbrown	7960277
4	0.75 mm ²	Cu tinned	SLSL	7.80 mm	red/red/white/white – red	7960283
4	1.00 mm ²	Cu	SLSL	7.80 mm	red/red/white/white – red	7960285
Type Teflon-insulated						
1	0.35 mm ²	Cu nickel-plated	T	1.30 mm	white	7960288
1	0.50 mm ²	Cu silver-plated	TW	1.30 mm	blue	7961613
2	0.24 mm ²	Cu	TW TX oval	1.90 x 2.90 mm	cores/sheath transparent	7960289
2	0.75 mm ²	Cu	TT oval	2.50 x 4.10 mm	red/white – red	7961620
2	0.40 mm ²	Cu	TXTX	1.20 x 2.00 mm	red/white – black	7960290
3	0.50 mm ²	Cu	T twisted	3.00 mm	blue/natural/natural	7961609
4	0.24 mm ²	Cu	TWCuTX	3.90 mm	2red/2white – blue	7963243
4	0.35 mm ²	Cu nickel-plated	TEHSiCTE	5.40 mm	red/red/white/white – black	7960307
4	0.75 mm ²	Cu tinned	TT	4.60 mm	red/white – red	7960300
6	0.50 mm ²	Cu	TT	5.40 mm	2red/1white/2black/1yellow – transparent	7961618
8	0.25 mm ²	Cu	TT	5.50 mm	transparent	7961605

Insulation:

GL = Fibreglass
 J = PVC up to 105 °C
 Y = PVC up to 70 °C
 SL + Si = Silicone
 T = FEP
 H = twisted

TW + TE = PTFE
 TX = PFA
 C + Cu = Copper wire braid
 P = Galvanized steel wire braid
 V = Stainless steel wire braid

Copper Cables

No. of cores	Core size	Core material	Insulation	Outer Ø approx.	Color code: core – sheath	Prod. No.
Type Teflon						
2	0.35 mm ²	Cu	TGL oval	2.10 x 3.10 mm	transparent – white	7961606
2	0.50 mm ²	Cu	TGL	3.40 mm	transparent/black – white with red code number	7961615
2	0.35 mm ²	Cu nickel-plated	TGLV	3.60 mm	sillvergrey – braid	7960301
2	0.35 mm ²	Cu nickel-plated	TGLV oval	1.90 x 3.40 mm	red/yellow – braid	7960291
2	0.50 mm ²	Cu tinned	TGLGLV	5.00 mm	transparent/natural – braid	7961616
2	1.50 mm ²	Cu nickel-plated	TGLP (TEX 136)	6.50 mm	blue/black – braid	7960295
3	0.35 mm ²	Cu	TGLV	3.30 mm	red/red/white – braid	7960292
4	0.25 mm ²	Cu nickel-plated	TXGLV	3.70 mm	red/red/yellow/yellow–braid	7961614
4	0.50 mm ²	Cu nickel-plated	TGLGLV	5.90 mm	natural – braid	7960298
4	0.50 mm ²	Cu	TGLV	4.00 mm	red/red/white/white	7961617
4	1.50 mm ²	Cu	TGLP	6.50 mm	2blue/2black – braid	7961612
6	0.35 mm ²	Cu nickel-plated	TWGLV	5.00 mm	2red/1white/2black/1yellow	7960297
8	0.25 mm ²	Cu	TTV	5.00 mm	cores/sheath transparent	7963292

Insulation

GL = Fibreglass
 J = PVC up to 105 °C
 Y = PVC up to 70 °C
 SL = Silicone
 T = FEP

TW = PTFE
 TX = PFA
 C = Copper wire braid
 P = Galvanized steel wire braid
 V = Stainless steel wire braid