

TTH200

Head mounted Temperature Transmitter



**HART, Pt100 (RTD), thermocouples,
Electrical isolation**

Input

- Resistance thermometer
- Thermocouples
- Resistance-type transmitters
- Voltages, mV voltages

Output

- 4 ... 20 mA, HART

Measurement deviation

- 0.1 K

Sensor error adjustment

Continuous sensor monitoring and self-monitoring

- Supply voltage monitoring
- Wire break and corrosion monitoring in accordance with NE 89

Unit software acc. to NE 53

SIL2 acc. to IEC 61508

Approvals for explosion protection

- ATEX, IECEx, Zone 0
- FM / CSA

Configuration

- DTM
- EDD

Contents

1	Specifications	3
1.1	Input	3
1.2	Output	3
1.3	Power supply (polarity safe)	3
2	General information	4
2.1	Ambient conditions	4
2.2	ElectroMagnetic Compatibility	4
2.3	Interference immunity	4
2.4	Mechanical design	4
2.5	SIL functional safety	4
2.6	Measuring accuracy	5
2.7	Operating influences	6
3	Communication	7
3.1	Configuration parameters	7
3.2	HART	7
4	Electrical connections	8
5	Dimensions	8
6	Ordering information	9
6.1	Accessories	10
6.2	Documentation available for ordering	10
7	Ex relevant specifications	11
7.1	TTH200-E1, Intrinsic Safety ATEX	11
7.2	TTH200-H1, Intrinsic Safety IECEX	11
7.3	Safety specifications for Intrinsic Safety ATEX / IECEX	11
7.4	TTH200-E2, Non-Sparking ATEX	11
7.5	TTH200-L1, Intrinsically Safe FM	11
7.6	TTH200-L2, Non-Incendive FM	11
7.7	TTH200-R1, Intrinsically Safe CSA	11
7.8	TTH200-R2, Non-Incendive CSA	11
8	Type AS LC display	12
8.1	Features	12
8.2	Specifications	12
8.3	Ex relevant specifications	12
9	Order form configuration	13

1 Specifications

1.1 Input

1.1.1 Resistance thermometers / Resistors

Resistance thermometer

Pt100 in accordance with IEC 60751, JIS C1604-81, MIL-T-24388,
Ni in accordance with DIN 43760, Cu

Resistance measurement

0 ... 500 Ω
0 ... 5000 Ω

Sensor connection type

Two-, three-, four-wire circuit

Connecting cable

Maximum sensor line resistance (R_W) for each line 50 Ω according to NE 89 (January 2009)

Three-wire circuit:
symmetrical sensor line resistances

Two-wire circuit:
compensation up to 100 Ω total line resistance

Measurement current

< 300 μA

Sensor short circuit

< 5 Ω (for resistance thermometer)

Sensor wire break

Measuring range: 0 ... 500 Ω > 0.6 ... 10 kΩ
Measuring range: 0 ... 5 kΩ > 5.3 ... 10 kΩ

Corrosion detection in accordance with NE 89

Three-wire resistance measurement > 50 Ω
Four-wire resistance measurement > 50 Ω

Sensor error signaling

Resistance thermometers: Short circuit and wire break
Linear resistance measurement: Wire break

1.1.2 Thermocouples / Voltages

Types

B, E, J, K, N, R, S, T in accordance with IEC 60584
U, L in accordance with DIN 43710
C, D in accordance with ASTM E-988

Voltages

-125 ... 125 mV
-125 ... 1100 mV

Connecting cable

Maximum sensor line resistance (R_W) for each line: 1.5 kΩ, total: 3 kΩ

Sensor wire-break monitoring in accordance with NE 89

Pulsed with 1 μA outside measurement interval
Thermocouple measurement 5.3 ... 10 kΩ
Voltage measurement 5.3 ... 10 kΩ

Input resistance

> 10 MΩ

Internal reference point

Pt1000, IEC 60751 Cl. B
(no additional jumpers necessary)

Sensor error signaling

Thermocouple: Wire break
Linear voltage measurement: Wire break

1.2 Output

Transmission characteristics

Temperature linear
Resistance linear
Voltage linear

Output signal

Configurable 4 ... 20 mA (standard)
Configurable 20 ... 4 mA
(dynamic range: 3.8 ... 20.5 mA in accordance with NE 43)

Simulation mode

3.5 ... 23.6 mA

Induced current consumption

< 3.5 mA

Maximum output current

23.6 mA

Configurable error current signal

Override 22 mA (20.0 ... 23.6 mA)
Underdrive 3.6 mA (3.5 ... 4.0 mA)

1.3 Power supply (polarity safe)

Two-wire technology; power lines = signal lines

Supply voltage

Non ignition-proof application with or without LCD:
 $U_S = 11 \dots 42 \text{ V DC}$
Ignition-proof applications with or without LCD:
 $U_S = 11 \dots 30 \text{ V DC}$

Max. permissible residual ripple for supply voltage

During communication in accordance with HART FSK "Physical Layer" specification, version 8.1 (August 1999) Section 8.1

Undervoltage detection

$U_{\text{Terminal-Mu}} < 10 \text{ V}$ results in $I_a = 3.6 \text{ mA}$

Maximum load

$R_{\text{Load}} = (\text{supply voltage} - 11 \text{ V}) / 0.022 \text{ A}$

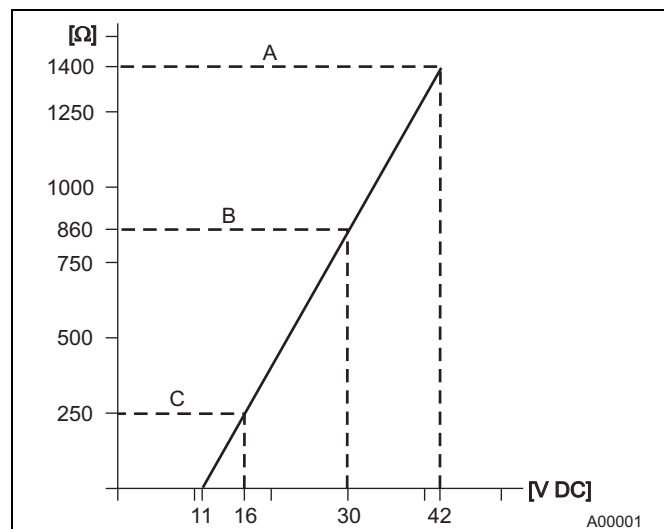

Fig. 1: Max. load depending on supply voltage

- A TTH200
- B TTH200 In ia hazardous area design
- C HART communication resistor

Maximum power consumption

$P = U_S \times 0.022 \text{ A}$

e.g., $U_S = 24 \text{ V} \rightarrow P_{\text{max}} = 0.528 \text{ W}$

2 General information

CE Marking

The TTH200 meets all requirements for the CE mark in accordance with IEC 61326 (2006)

Electrical isolation

3.5 kV DC (approx. 2.5 kV AC) 60 s, input to output

MTBF time

28 years at 60 °C ambient temperature

Input filter

50 / 60 Hz

Switch-on delay

< 10 s ($I_a \leq 3.6$ mA during starting cycle)

Warm-up time

5 minutes

Ramp-up time t90

400 ... 1000 ms

Rate updated

10/s, independent of sensor type and sensor circuit

Output filter

Digital filter 1st order: 0 ... 100 s

2.1 Ambient conditions

Ambient temperature

Standard: -40 ... 85 °C (-40 ... 185 °F)

Optional: -50 ... 85 °C (-58 ... 185 °F)

Restricted range during operation with LC display and with hazardous area design

Transport/storage temperature

-50 ... 85 °C (-58 ... 185 °F)

Climate class

Cx -40 ... 85 °C (-40 ... 185 °F) at

5 ... 95 % relative humidity, DIN EN 60654-1

Max. permissible humidity

100 % relative humidity, IEC 60068-2-30

Vibration resistance

10 ... 2,000 Hz at 5 g in acc. with IEC 60068-2-6, during operation and transport

Shock

gn = 30 in acc. with IEC 68-2-27, during operation and transport

Ingress protection

Supply circuit: IP 20

Measurement current circuit: IP 00, or IP class of bay

2.2 ElectroMagnetic Compatibility

Emitted interference in accordance with IEC EN 61326 (2006) and Namur NE 21 (February 2004)

2.3 Interference immunity

Interference-immune in accordance with IEC 61326 (2006) and Namur NE 21 (August 2007)

Pt100: measuring range 0 ... 100 °C (32 ... 212 °F), span 100 K

Type of test	Testing accuracy	Influence
Burst to signal/data lines	2 kV	< 0.5 %
Static discharge:		
• Contact plate (indirect)	8 kV	No
• Supply terminals ¹⁾	6 kV	No
• Sensor terminals ¹⁾	4 kV	No
Radiated field 80 MHz ... 2 GHz	10 V/m	< 0.5 %
Coupling 150 kHz ... 80 MHz	10 V	< 0.5 %
Surge: between the supply lines	0.5 kV	No malfunction
Line to ground	1 kV	No malfunction

1) Air discharge (at 1 mm (0.04 inch) distance)

2.4 Mechanical design

Dimensions

See Section 5, "Dimensions"

Weight

50 g

Material

Housing: polycarbonate

Color: Gray RAL 9002

Sealing compound: Hard sealing compound

Installation conditions

Installation position: No limitations

Installation options: connection heads acc. to DIN 43729 form B,

Rail mounting (35 mm) acc. to EN 60175 by means of latching base,

field-mount housing

Electrical connection

Terminals (captive screws) incl. soldering tags

Lines up to max. 1.5 mm² (AWG 16)

Connection for handheld terminal

2.5 SIL functional safety

Conforms with IEC 61508 as regards use in safety-related applications, up to and including SIL 2.

2.6 Measuring accuracy

Includes linearity deviation. reproducibility/hysteresis at 23 °C (73.4 °F) ± 5 K and 20 V supply voltage

Information on measuring accuracy corresponds to 3 σ (Gaussian distribution)

Input element		Measuring range limits	Minimum span	Digital measuring accuracy (24-bit A/D converter)	D/A measuring accuracy (16-bit DA)
Standard	Sensor				
Resistance thermometer/resistor					
IEC 60 751	Pt10 (a=0.003850)	-200 ... 850 °C (-328 ... 1562 °F)	10 °C (18 °F)	± 0.80 °C (± 1.44 °F)	± 0.05 %
	Pt50 (a=0.003850)	-200 ... 850 °C (-328 ... 1562 °F)	10 °C (18 °F)	± 0.16 °C (± 0.29 °F)	± 0.05 %
	Pt100 (a=0.003850) ²⁾	-200 ... 850 °C (-328 ... 1562 °F)	10 °C (18 °F)	± 0.08 °C (± 0.14 °F)	± 0.05 %
	Pt200 (a=0.003850)	-200 ... 850 °C (-328 ... 1562 °F)	10 °C (18 °F)	± 0.24 °C (± 0.43 °F)	± 0.05 %
	Pt500 (a=0.003850)	-200 ... 850 °C (-328 ... 1562 °F)	10 °C (18 °F)	± 0.16 °C (± 0.29 °F)	± 0.05 %
	Pt1000 (a=0.003850)	-200 ... 850 °C (-328 ... 1562 °F)	10 °C (18 °F)	± 0.08 °C (± 0.14 °F)	± 0.05 %
JIS C1604-81	Pt10 (a=0.003916)	-200 ... 645 °C (-328 ... 1193 °F)	10 °C (18 °F)	± 0.80 °C (± 1.44 °F)	± 0.05 %
	Pt50 (a=0.003916)	-200 ... 645 °C (-328 ... 1193 °F)	10 °C (18 °F)	± 0.16 °C (± 0.29 °F)	± 0.05 %
	Pt100 (a=0.003916)	-200 ... 645 °C (-328 ... 1193 °F)	10 °C (18 °F)	± 0.08 °C (± 0.14 °F)	± 0.05 %
MIL-T-24388	Pt10 (a=0.003920)	-200 ... 850 °C (-328 ... 1562 °F)	10 °C (18 °F)	± 0.80 °C (± 1.44 °F)	± 0.05 %
	Pt50 (a=0.003920)	-200 ... 850 °C (-328 ... 1562 °F)	10 °C (18 °F)	± 0.16 °C (± 0.29 °F)	± 0.05 %
	Pt100 (a=0.003920)	-200 ... 850 °C (-328 ... 1562 °F)	10 °C (18 °F)	± 0.08 °C (± 0.14 °F)	± 0.05 %
	Pt200 (a=0.003920)	-200 ... 850 °C (-328 ... 1562 °F)	10 °C (18 °F)	± 0.24 °C (± 0.43 °F)	± 0.05 %
	Pt500 (a=0.003920)	-200 ... 850 °C (-328 ... 1562 °F)	10 °C (18 °F)	± 0.16 °C (± 0.29 °F)	± 0.05 %
	Pt1000 (a=0.003920)	-200 ... 850 °C (-328 ... 1562 °F)	10 °C (18 °F)	± 0.08 °C (± 0.14 °F)	± 0.05 %
DIN 43760	Ni50 (a=0.006180)	-60 ... 250 °C (-76 ... 482 °F)	10 °C (18 °F)	± 0.16 °C (± 0.29 °F)	± 0.05 %
	Ni100 (a=0.006180)	-60 ... 250 °C (-76 ... 482 °F)	10 °C (18 °F)	± 0.08 °C (± 0.14 °F)	± 0.05 %
	Ni120 (a=0.006180)	-60 ... 250 °C (-76 ... 482 °F)	10 °C (18 °F)	± 0.08 °C (± 0.14 °F)	± 0.05 %
	Ni1000 (a=0.006180)	-60 ... 250 °C (-76 ... 482 °F)	10 °C (18 °F)	± 0.08 °C (± 0.14 °F)	± 0.05 %
	Cu10 (a=0.004270)	-50 ... 200 °C (-58 ... 392 °F)	10 °C (18 °F)	± 0.80 °C (± 1.44 °F)	± 0.05 %
Cu100 (a=0.004270)	-50 ... 200 °C (-58 ... 392 °F)	10 °C (18 °F)	± 0.08 °C (± 0.14 °F)	± 0.05 %	
	Resistance measurement	0 ... 500 Ω	4 Ω	± 32 mΩ	± 0.05 %
	Resistance measurement	0 ... 5000 Ω	40 Ω	± 320 mΩ	± 0.05 %
Thermocouples³⁾/voltages					
IEC 60584	Type K (Ni10Cr-Ni5)	-270 ... 1372 °C (-454 ... 2502 °F)	50 °C (90 °F)	± 0.35 °C (± 0.63 °F)	± 0.05 %
	Type J (Fe-Cu45Ni)	-210 ... 1200 °C (-346 ... 2192 °F)	50 °C (90 °F)	± 0.35 °C (± 0.63 °F)	± 0.05 %
	Type N (Ni14CrSi-NiSi)	-270 ... 1300 °C (-454 ... 2372 °F)	50 °C (90 °F)	± 0.35 °C (± 0.63 °F)	± 0.05 %
	Type T (Cu-Cu45Ni)	-270 ... 400 °C (-454 ... 752 °F)	50 °C (90 °F)	± 0.35 °C (± 0.63 °F)	± 0.05 %
	Type E (Ni10Cr-Cu45Ni)	-270 ... 1000 °C (-454 ... 1832 °F)	50 °C (90 °F)	± 0.35 °C (± 0.63 °F)	± 0.05 %
	Type R (Pt13Rh-Pt)	-50 ... 1768 °C (-58 ... 3215 °F)	100 °C (180 °F)	± 0.95 °C (± 1.71 °F)	± 0.05 %
	Type S (Pt10Rh-Pt)	-50 ... 1768 °C (-58 ... 3215 °F)	100 °C (180 °F)	± 0.95 °C (± 1.71 °F)	± 0.05 %
	Type B (Pt30Rh-Pt6Rh)	-0 ... 1820 °C (32 ... 3308 °F)	100 °C (180 °F)	± 0.95 °C (± 1.71 °F)	± 0.05 %
DIN 43710	Type L (Fe-CuNi)	-200 ... 900 °C (-328 ... 1652 °F)	50 °C (90 °F)	± 0.35 °C (± 0.63 °F)	± 0.05 %
	Type U (Cu-CuNi)	-200 ... 600 °C (-328 ... 1112 °F)	50 °C (90 °F)	± 0.35 °C (± 0.63 °F)	± 0.05 %
ASTM E-988	Type C	-0 ... 2315 °C (32 ... 4200 °F)	100 °C (180 °F)	± 1.35 °C (± 2.43 °F)	± 0.05 %
	Type D	-0 ... 2315 °C (32 ... 4200 °F)	100 °C (180 °F)	± 1.35 °C (± 2.43 °F)	± 0.05 %
	Voltage measurement	-125 ... 125 mV	2 mV	± 12 μV	± 0.05 %
	Voltage measurement	-125 ... 1100 mV	20 mV	± 120 μV	± 0.05 %

Long-term drift

± 0.05 °C (± 0.09 °F) or ± 0.05 %¹⁾ per year. the larger value applies.

1) Percentages refer to the configured measuring span

2) Standard model

3) Include the internal reference point error for digital measuring accuracy: Pt1000. IEC 60751 Cl. B

4) Without reference point error

2.7 Operating influences

The percentages refer to the configured measuring span.

Supply voltage influence / load influence: within the specified limits for the voltage/load, the total influence is less than 0.001 % per volt

Common-mode interference: no influence up to 100 V_{eff} (50 Hz) or 50 V DC

Ambient temperature influence: based on 23 °C (73.4 °F) for ambient temperature range -40 ... 85 °C (-40 ... 185 °F)⁴⁾

Sensor	Influence of ambient temperature per 1 °C (1.8 °F) deviation to 23 °C (73.4 °F) for digital measurement	Influence of ambient temperature ¹⁾²⁾ per 1 °C (1.8 °F) deviation to 23 °C (73.4 °F) for D/A converter
Resistance thermometer for two-, three-, four-wire circuits		
Pt10 IEC, JIS, MIL	± 0.04 °C (± 0.072 °F)	± 0.003 %
Pt50 IEC, JIS, MIL	± 0.008 °C (± 0.014 °F)	± 0.003 %
Pt100 IEC, JIS, MIL	± 0.004 °C (± 0.007 °F)	± 0.003 %
Pt200 IEC, MIL	± 0.02 °C (± 0.036 °F)	± 0.003 %
Pt500 IEC, MIL	± 0.008 °C (± 0.014 °F)	± 0.003 %
Pt1000 IEC, MIL	± 0.004 °C (± 0.007 °F)	± 0.003 %
Ni50 DIN 43760	± 0.008 °C (± 0,014 °F)	± 0.003 %
Ni100 DIN 43760	± 0.004 °C (± 0,007 °F)	± 0.003 %
Ni120 DIN 43760	± 0.003 °C (± 0,005 °F)	± 0.003 %
Ni1000 DIN 43760	± 0.004 °C (± 0,007 °F)	± 0.003 %
Cu10	± 0.04 °C (± 0,072 °F)	± 0.003 %
Cu100	± 0.004 °C (± 0,007 °F)	± 0.003 %
Resistance measurement 0 ... 500 Ω	± 0.002 Ω	± 0.003 %
0 ... 5000 Ω	± 0.02 Ω	± 0.003 %
Thermocouple, for all defined types	± [(0.001 % x (ME[mV] / MS[mv]) + (100 % x (0.009 °C / MS [°C]))] ³⁾	± 0.003 %
Voltage measurement -125 ... 125 mV	± 1.5 μV	± 0.003 %
-125 ... 1100 mV	± 15 μV	± 0.003 %

1) Percentages refer to the configured measuring span of the analog output signal

2) Effect on DA converter

3) ME = voltage value of the thermocouple at the end of the measuring range in accordance with the standard
MA = voltage value of the thermocouple at the start of the measuring range in accordance with the standard
MS = voltage value of the thermocouple over the measuring span in accordance with the standard. MS = (ME - MA)

4) In the case of the option to expand the ambient temperature range up to -50 °C (-58 °F), the causal variables are doubled in the range between -50 ... -40 °C (-58 ... -40 °F).

3 Communication

3.1 Configuration parameters

Measurement type

- Sensor type, connection type
- Error signaling
- Measurement range
- General information, e.g., TAG number
- Damping
- Signal simulation of output
- For additional information, see Section 9, "Order form configuration"

Write protection

- Software write protection

Diagnostic information in accordance with NE 107

- Sensor error (wire break or short circuit)
- Device error
- Over/under alarm limits
- Over/under measuring range
- Simulation activated

Diagnostic signaling

- Over/underdrive in accordance with NE 43
- HART diagnostics

3.2 HART

The device is listed with the HART Communication Foundation.

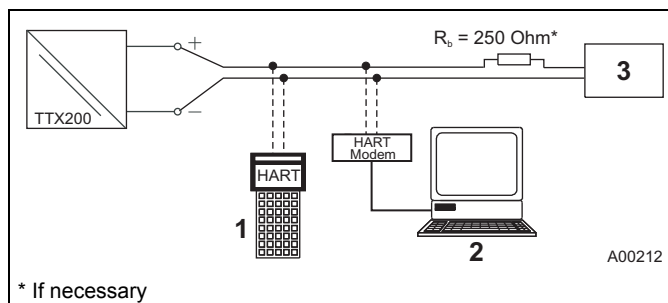

Fig. 2: Example for HART interface connection

- 1 Handheld terminal
- 2 FDT / DTM technology
- 3 Power unit (process interface)

Manufacturer ID:	0x1A
Device ID:	0x0A
Profile:	HART 5.1
Configuration:	DTM EDD
Transmission signal:	BELL Standard 202

Operating modes

- Point-to-point communication mode: standard (general address 0)
- Multidrop mode (addressing 1 ... 15)
- Burst mode

Configuration options and tools

- Device management/asset management tools
- FDT/DTM technology – via TTX200 DTM driver
- EDD - via TTX200 EDD driver

Diagnostic signaling

- Over/underdrive in accordance with NE 43
- HART diagnostics

4 Electrical connections

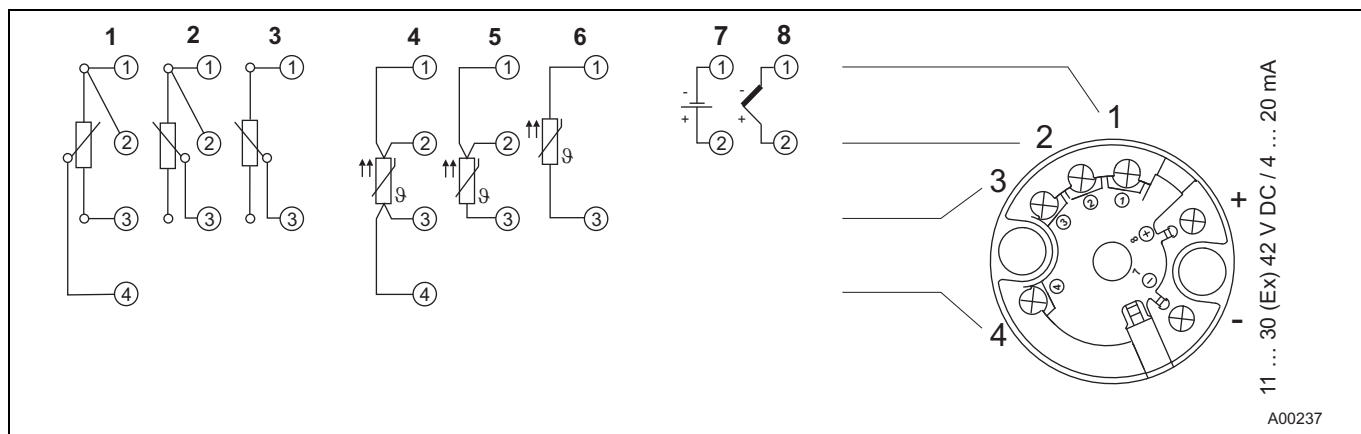

Fig. 3

- | | | |
|-------------------------------------|---------------------------|-----------------------|
| 1 Potentiometer, Four-wire circuit | 4 RTD, Four-wire circuit | 7 Voltage measurement |
| 2 Potentiometer, Three-wire circuit | 5 RTD, Three-wire circuit | 8 Thermocouple |
| 3 Potentiometer, Two-wire circuit | 6 RTD, Two-wire circuit | |

5 Dimensions

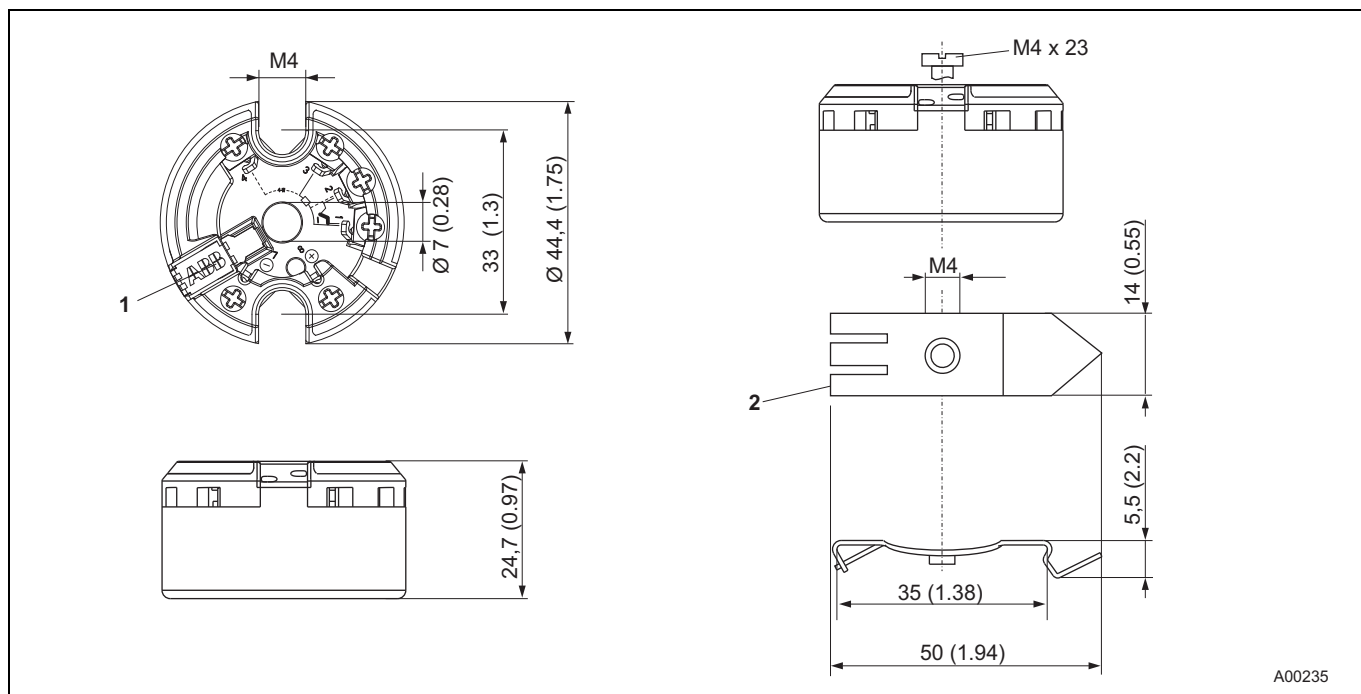

Fig. 4: Dimensions in mm/inch

- 1 Interface for type AS LC display (not suitable for type A LC display)
- 2 Latching base for 35 mm (1.38 inch) rail mounting acc. to EN 60175

6 Ordering information

	Main order number						Add. order no.
	Version number	1	2	3	4	5	
TTH200 head-mounted temperature transmitter, HART, Pt100 (RTD), thermocouples, electrical isolation	TTH200	X	X	X	X	X	XX
Explosion protection							
Without explosion protection		Y	0				
ATEX intrinsically safe:		E	1				
Zone 0: II 1 G EEx ia IIC T6,							
Zone 1 (0): II 2 (1) G EEx [ia] ib IIC T6,							
Zone 1 (20): II 2 G (1D) Ex [iaD] ib IIC T6							
ATEX non-incendive (nA):		E	2				
Zone 2: II 3G EEx nA II T6							
IECEX intrinsic safety:		H	1				
Zone 0: Ex ia IIC T6,							
Zone 1 (0): Ex [ia] ib IIC T6,							
Zone 1 (20): Ex [iaD] ib IIC T6							
FM intrinsically safe:		L	1				
Class I, Div.1+2, Groups A,B,C,D Class I, Zone 0, AEx ia IIC T6							
FM non-incendive:		L	2				
Class I, Div.2, Groups A,B,C,D							
CSA intrinsically safe:		R	1				
Class I, Div.1+2, Groups A,B,C,D							
CSA non-incendive:		R	2				
Class I, Div.2, Groups A,B,C,D							
Kazakhstan - metrological approval		G	3				
Kazakhstan - metrological approval and GOST Ex i		G	4				
Ukraine - metrological approval		G	5				
Ukraine - metrological approval and GOST Ex i		G	6				
Belarus - metrological approval		M	5				
Belarus - metrological approval and GOST Ex i		M	6				
Communication protocol							
HART					H		
Configuration							
Standard configuration						B S	
Customer-specific configuration with report, no spec. user characteristics					1)	B F	
Certificates							
SIL2 declaration of conformity							CS
Certificate of compliance 2.1 to EN 10204 for order conformity							C4
Acceptance test certificate 3.1 to EN 10204 for visual and functional checks							C6
Calibration certificate							
5-point factory calibration certificate							EM
Acceptance test certificate 3.1 to EN 10204 for 5-point calibration							EP
Expanded ambient temperature range							
-50 ... 85 °C (-58 ... 185 °F)						2)	SE
Language of documentation							
German							M1
English							M5
Western Europe/Scandinavia language package (languages: DE, EN, DA, ES, FR, IT, NL, PT, FI, SV)							MW
Eastern Europe language package (languages: DE, EL, CS, ET, LV, LT, HU, PL, SK, SL, RO, BG)							ME

1) E.g., customer-specific measuring range, TAG no.

2) Not available with explosion protection code L1, L2, R1, R2

6.1 Accessories

Description	Order number
TTH latching base set (packaging unit: 10 pcs.), for 35 mm rail in acc. with EN 60175 (incl. mounting screws)	3KXT091230L0001
TTH latching base set (packaging unit: 1 pcs.), for 35 mm rail in acc. with EN 60175 (incl. mounting screws)	3KXT091230L0002

6.2 Documentation available for ordering

Description	Order number
TTH200 documentation on CD-ROM	3KXT231002R0800
TTH200 commissioning instructions, English	3KXT231002R4401
TTH200 commissioning instructions, German	3KXT231002R4403
TTH200 commissioning instructions, Western Europe / Scandinavia language package	3KXT231002R4493
TTH200 commissioning instructions, Eastern Europe language package	3KXT231002R4494

7 Ex relevant specifications

The TTH200 complies with the requirements of ATEX Directive 94/9/EC.

7.1 TTH200-E1, Intrinsic Safety ATEX

Explosion protection

Approved for use in Zone 0

Designation

II 1G EEx ia IIC T6 (Zone 0)
II 2 (1) G EEx [ia] ib IIC T6 (Zone 1 [0])
II 2G(1D) Ex [iaD] ib IIC T6 (Zone 1 [20])

EC type-examination test certificate PTB 05 ATEX 2017 X

7.2 TTH200-H1, Intrinsic Safety IECEx

Explosion protection

Approved for use in Zone 0.

Designation

Ex ia IIC T6 (Zone 0)
Ex [ia] ib IIC T6 (Zone 1 [0])
Ex [iaD] ib IIC T6 (Zone 1 [20])

For further information, see certificate

7.3 Safety specifications for Intrinsic Safety ATEX / IECEx

Temperature table

Temperature class	Permissible ambient temperature range	
	Device category 1 use	Device category 2 use
T6	-50 ... 44 °C (-58 ... 111.2 °F)	-50 ... 56 °C (-58 ... 132.8 °F)
T5	-50 ... 56 °C (-58 ... 132.8 °F)	-50 ... 71 °C (-58 ... 159.8 °F)
T4, T3, T2, T1	-50 ... 60 °C (-58 ... 140.0 °F)	-50 ... 85 °C (-58 ... 185.0 °F)

Protection type Intrinsic Safety Ex ia IIC (Part 1)

	Supply circuit	Measurement current circuit / passive transducer (RTD)
Max. voltage	$U_i = 30 \text{ V}$	$U_o = 6.5 \text{ V}$
Short circuit current	$I_i = 130 \text{ mA}$	$I_o = 25 \text{ mA}$
Max. power	$P_i = 0.8 \text{ W}$	$P_o = 38 \text{ mW}$
Internal inductance	$L_i = 0.5 \text{ mH}$	$L_o = 0 \text{ mH}$
Internal capacitance	$C_i = 5 \text{ nF}$	$C_o = 49 \text{ nF}$
Maximum permissible external inductance		$L_o = 5 \text{ mH}$
Maximum permissible external capacitance		$C_o = 1.55 \text{ }\mu\text{F}$

Protection type Intrinsic Safety Ex ia IIC (Part 2)

	Measurement current circuit / active transducer (TC)	Display interface
Max. voltage	$U_o = 1.2 \text{ V}$	$U_o = 6.2 \text{ V}$
Short circuit current	$I_o = 50 \text{ mA}$	$I_o = 65.2 \text{ mA}$
Max. power	$P_o = 60 \text{ mW}$	$P_o = 101 \text{ mW}$
Internal inductance	$L_i = 0 \text{ mH}$	$L_i = 0 \text{ mH}$
Internal capacitance	$C_i = 49 \text{ nF}$	$C_i = 0 \text{ nF}$
Maximum permissible external inductance	$L_o = 5 \text{ mH}$	$L_o = 5 \text{ mH}$
Maximum permissible external capacitance	$C_o = 1.05 \text{ }\mu\text{F}$	$C_o = 1.4 \text{ }\mu\text{F}$

7.4 TTH200-E2, Non-Sparking ATEX

Explosion protection

Approved for use in Zone 2

Designation

II 3G EEx nA II T6

ABB manufacturer's declaration in accordance with ATEX Directive

Temperature table

Temperature class	Device category 2 use
T6	-50 ... 56 °C (-58 ... 132,8 °F)
T5	-50 ... 71 °C (-58 ... 159,8 °F)
T4	-50 ... 85 °C (-58 ... 185,0 °F)

7.5 TTH200-L1, Intrinsically Safe FM

Class I, Div. 1 + 2, Groups A, B, C, D
Class I, Zone 0, AEx ia IIC T6
Control drawing: TTH200-L1H

7.6 TTH200-L2, Non-Incendive FM

Class I, Div. 2, Groups A, B, C, D
Control drawing: TTH200-L2H

7.7 TTH200-R1, Intrinsically Safe CSA

Class I, Div. 1 + 2, Groups A, B, C, D
Class I, Zone 0, Ex ia Group IIC T6
Control drawing: TTH200-R1H

7.8 TTH200-R2, Non-Incendive CSA

Class I, Div. 2, Groups A, B, C, D
Control drawing: TTH200-R2H (1)
Control drawing: TTH200-R2H (2) (no conduit)

8 Type AS LC display

Can only be ordered in conjunction with temperature sensors

CE Marking

The type AS LC display meets all requirements for the CE mark in accordance with IEC 61326 (2006)

8.1 Features

Transmitter-controlled graphic LC display without configuration function

Sign, 4 digits, 2 decimal places
Rotatable in 12 increments of 30°

Display options

Process data for sensors
Bar display
Output %

Display diagnostic information related to transmitter and sensor status

8.2 Specifications

Temperature range

-20 ... 70 °C (-4 ... 158 °F)
Restricted display function in range:
-50 ... -20 °C (-58 ... -4 °F) ¹⁾
or
70 ... 85 °C (158 ... 185 °F)

Humidity

0 ... 100 %, condensation permitted

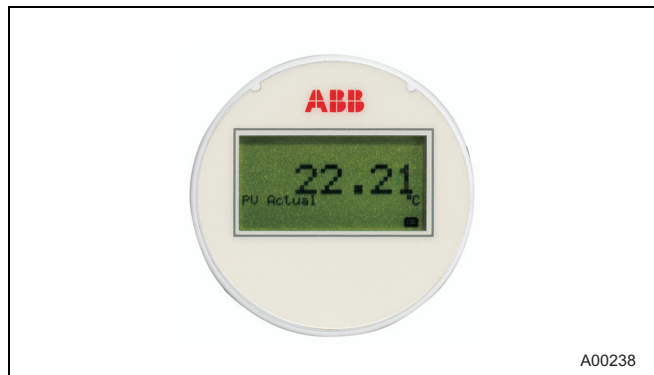

Fig. 5

1) Additional mechanical protection is required for this range

8.3 Ex relevant specifications

8.3.1 Intrinsic Safety ATEX

Explosion protection

Approved for use in Zone 0.

Designation

II 1G Ex ia IIC T6

EC type-examination certificate PTB 05 ATEX 2079 X

8.3.2 Intrinsic Safety IECEx

Explosion protection

Approved for use in Zone 0.

Designation

Ex ia IIC T6

For further information, see certificate

8.3.3 Safety specifications for Intrinsic Safety ATEX / IECEx

Temperature table

Temperature class	Permissible ambient temperature range	
	Device category 1 use	Device category 2 use
T6	-40 ... 44 °C (-40 ... 111.2 °F)	-40 ... 56 °C (-40 ... 132.8 °F)
T5	-40 ... 56 °C (-40 ... 132.8 °F)	-40 ... 71 °C (-40 ... 159.8 °F)
T4	-40 ... 60 °C (-40 ... 140 °F)	-40 ... 85 °C (-40 ... 185 °F)

Protection type intrinsic safety Ex ia IIC

	Supply circuit
Max. voltage	$U_i = 9 \text{ V}$
Short circuit current	$I_i = 65.2 \text{ mA}$
Max. power	$P_i = 101 \text{ W}$
Internal inductance	$L_i = 0 \text{ mH}$
Internal capacitance	$C_i = 0.4 \text{ nF}$

8.3.4 Intrinsically Safe FM

I.S. Class I Div 1 and Div 2, Group: A, B, C, D or
I.S. Class I Zone 0 AEx ia IIC T*
Temp. Ident: T6 $T_{amb} 56 \text{ °C}$, T4 $T_{amb} 85 \text{ °C}$
 $U_i / V_{max} = 9\text{V}$, $I_i / I_{max} < 65.2 \text{ mA}$, $P_i = 101 \text{ mW}$
 $C_i = 0.4 \text{ }\mu\text{F}$; $L_i = 0$
Control Drawing: SAP_214 748

8.3.5 Non-Incendive FM

N.I. Class I Div 2, Group: A, B, C, D or
Ex nL IIC T*, Class I Zone 2
Temp. Ident: T6 $T_{amb} 60 \text{ °C}$, T4 $T_{amb} 85 \text{ °C}$
 $U_i / V_{max} = 9\text{V}$, $I_i / I_{max} < 65.2 \text{ mA}$, $P_i = 101 \text{ mW}$
 $C_i = 0.4 \text{ }\mu\text{F}$; $L_i = 0$
Control Drawing: SAP_214 751

8.3.6 Intrinsically Safe CSA

I.S. Class I Div 1 and Div 2; Group: A, B, C, D or
I.S. Zone 0 Ex ia IIC T*
*Temp. Ident T6 $T_{amb} 56 \text{ °C}$, T4 $T_{amb} 85 \text{ °C}$
 $U_i / V_{max} = 9\text{V}$, $I_i / I_{max} < 65.2 \text{ mA}$; $P_i = 101 \text{ mW}$
 $C_i < 0.4 \text{ }\mu\text{F}$, $L_i = 0$
Control Drawing: SAP_214 749

8.3.7 Non-Incendive CSA

N.I. Class I Div 2, Group: A, B, C, D or
Ex nL IIC T*, Class I Zone 2
*Temp. Ident T6, $T_{amb} 60 \text{ °C}$, T4 $T_{amb} 85 \text{ °C}$
 $U_i / V_{max} = 9\text{V}$, $I_i / I_{max} < 65.2 \text{ mA}$, $P_i = 101 \text{ mW}$
 $C_i < 0.4 \text{ }\mu\text{F}$, $L_i = 0$
Control Drawing: SAP_214 750

9 Order form configuration

Data relating to customer-specific configuration

Configuration		Selection
IEC 60 751	Resistance thermometer	<input type="checkbox"/> Pt10 <input type="checkbox"/> Pt50 <input type="checkbox"/> Pt100 (standard)
		<input type="checkbox"/> Pt200 <input type="checkbox"/> Pt500 <input type="checkbox"/> Pt1000
JIS C1604-81		<input type="checkbox"/> Pt10 <input type="checkbox"/> Pt50 <input type="checkbox"/> Pt100
MIL-T-24388		<input type="checkbox"/> Pt10 <input type="checkbox"/> Pt50 <input type="checkbox"/> Pt100 <input type="checkbox"/> Pt200 <input type="checkbox"/> Pt500 <input type="checkbox"/> Pt1000
DIN 43760		<input type="checkbox"/> Ni50 <input type="checkbox"/> Ni100 <input type="checkbox"/> Ni120 <input type="checkbox"/> Ni1000
Cu	<input type="checkbox"/> Cu10 <input type="checkbox"/> Cu100	
	Resistance measurement	<input type="checkbox"/> 0 ... 500 Ω <input type="checkbox"/> 0 ... 5000 Ω
IEC 584	Thermocouple	<input type="checkbox"/> Type K <input type="checkbox"/> Type J <input type="checkbox"/> Type N <input type="checkbox"/> Type R <input type="checkbox"/> Type S <input type="checkbox"/> Type T <input type="checkbox"/> Type E <input type="checkbox"/> Type B
DIN 43710		<input type="checkbox"/> Type L <input type="checkbox"/> Type U
ASTM E-988		<input type="checkbox"/> Type C <input type="checkbox"/> Type D
	Voltage measurement	<input type="checkbox"/> -125 ... 125 mV <input type="checkbox"/> -125 ... 1100 mV
Sensor circuit (for resistance thermometer and resistance measurement only)		<input type="checkbox"/> Two-wire <input type="checkbox"/> Three-wire (standard) <input type="checkbox"/> Four-wire Two-wire circuit: Compensation of sensor line resistance max. 100 Ω <input type="checkbox"/>Ω
Reference point (for thermocouples only)		<input type="checkbox"/> Internal (for standard thermocouples except type B) <input type="checkbox"/> None (type B) <input type="checkbox"/> External/temperature: °C
Measurement range		<input type="checkbox"/> Measuring start: (Standard: 0) <input type="checkbox"/> Measuring end: (Standard: 100)
Unit		<input type="checkbox"/> Celsius (standard) <input type="checkbox"/> Fahrenheit <input type="checkbox"/> Rankine <input type="checkbox"/> Kelvin
Characteristic behavior		<input type="checkbox"/> Rising 4 ... 20 mA (standard) <input type="checkbox"/> Falling 20 ... 4 mA
Output behavior for error		<input type="checkbox"/> Override/22 mA (standard) <input type="checkbox"/> Underdrive/3.6 mA
Output attenuation (T ₆₃)		<input type="checkbox"/> Off (standard) <input type="checkbox"/> seconds (1 ... 100 s)
TAG number		<input type="checkbox"/> (max. 8 characters)
Software write protection		<input type="checkbox"/> Off (standard) <input type="checkbox"/> On

Contact us

ABB Ltd.

Salterbeck Trading Estate
Workington, Cumbria
CA14 5DS
UK
Phone: +44 (0)1946 830 611
Fax: +44 (0)1946 832 661

ABB Inc.

125 E. County Line Road
Warminster PA 18974
USA
Phone: +1 215 674 6000
Fax: +1 215 674 7183

ABB Automation Products GmbH

Schillerstr. 72
32425 Minden
Germany
Phone: +49 551 905-534
Fax: +49 551 905-555

www.abb.com

Note

We reserve the right to make technical changes or modify the contents of this document without prior notice. With regard to purchase orders, the agreed particulars shall prevail. ABB does not accept any responsibility whatsoever for potential errors or possible lack of information in this document.

We reserve all rights in this document and in the subject matter and illustrations contained therein. Any reproduction, disclosure to third parties or utilization of its contents - in whole or in parts - is forbidden without prior written consent of ABB.

Copyright© 2010 ABB
All rights reserved