

TZIDC-200 Electro-Pneumatic Positioner

Compact, well-proven, and flexible



HART protocol

For 4 ... 20 mA two-wire technology,
Flameproof (Enclosure)

Low operating cost

Compact design

Well-proven technology and intelligence

Robust and environmentally ruggedized

Wide operating temperature range

— -40 ... 85 °C (-40 ... 185 °F)

Easy to commission, “single pushbutton” operating philosophy

Mechanical position indicator

ATEX, FM, CSA, GOST and IECEx approvals

For SIL2 safety loops

Contents

1	Description	3
1.1	Pneumatics.....	3
1.2	Operation.....	3
1.3	Communication	3
1.4	Inputs and outputs.....	3
1.5	Modular design.....	3
2	Mounting versions	5
2.1	To linear actuators in accordance with the standard	5
2.2	To rotary actuators in accordance with the standard	5
2.3	Integral mounting to control valves	5
2.4	Special actuator-specific mounting	5
3	Operation	7
3.1	General.....	7
3.2	Operator panel	8
4	Communication	9
4.1	DTM.....	9
4.2	LKS adapter (RS-232 interface converter).....	9
4.3	FSK Modem	9
5	Specifications	10
5.1	Input.....	10
5.2	Output.....	10
5.3	Travel.....	10
5.4	Air supply.....	10
5.5	Transmission data and influences.....	10
5.6	Environmental capabilities	11
5.7	Housing	11
5.8	Safety Integrity Level.....	11
5.9	Explosion protection	12
5.10	Options	12
5.11	Accessories	13
6	Electrical connections	14
7	Dimensions	16
8	Ordering information	19
8.1	Accessories	21

1 Description

The TZIDC-200 is an electronically configurable positioner with communication capabilities, mounting to pneumatic linear or rotary actuators. It features a small and compact design, a modular construction, and an excellent cost-performance ratio.

Fully automatic determination of the control parameters and adaptation to the final control element yield considerable time savings and an optimal control behavior.

1.1 Pneumatics

An I/P module with subsequent pneumatic amplifier is used to control the pneumatic actuator. The well-proven I/P module proportionally converts the permanent electrical positioning signal from the CPU into a pneumatic signal used to adjust a 3/3-way valve.

The air flow for pressurizing or depressurizing the actuator is continuously adjusted. As a result, excellent control is achieved. When reaching the set point, the 3/3-way valve is closed in center position to minimize the air consumption.

Four different pneumatics versions are available: for single-acting or double-acting actuators, each with "fail-safe" or "fail-freeze" function.

1.1.1 "Fail-safe" function

If the electrical power supply fails, the positioner output 1 is depressurized, and the pneumatic actuator's return spring moves the valve to the defined safe position. In case of a double-acting actuator the second output 2 is additionally pressurized.

1.1.2 "Fail-freeze" function

If the electrical power supply should fail, the positioner output 1 (and 2, if applicable) is closed and the pneumatic actuator stops ("freezes") the valve in the current position. If compressed air supply should fail, the positioner depressurizes the actuator.

1.2 Operation

The positioner has a built-in operating panel providing a 2-line LCD and 4 pushbuttons for optimal local configuration, commissioning and operational monitoring.

Alternatively, the appropriate configuration program and the available communication option can be used.

1.3 Communication

The standard TZIDC-200 model has a local communication interface (LKS connector). Additionally, a "HART communication" option for communication via the 20 mA signal is available. Both communications are based on the HART Protocol.

1.4 Inputs and outputs

In addition to its input for the analog position set point the TZIDC-200 positioner is equipped with a digital input which can be used to activate various protective functions in the device via the process control system. A digital output allows you to output collective alarms or fault messages.

1.5 Modular design

The TZIDC-200 basic model can be enhanced at any time by retrofitting optional equipment. Option modules for analog or digital position feedback or a shutdown-module can be installed. Additionally, a mechanical position indicator, proximity switches or 24 V microswitches are available for indicating the position independently of the mother board function.

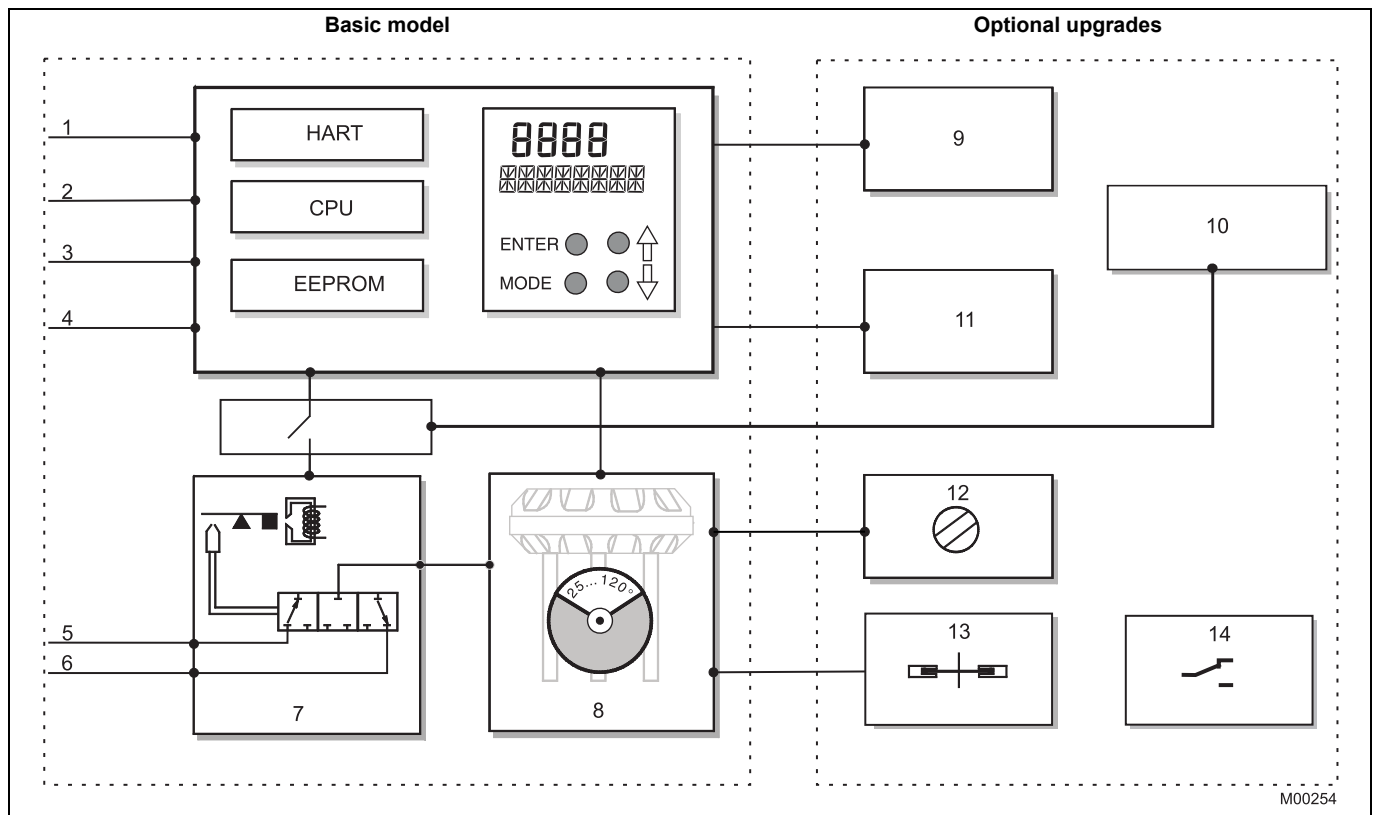

Fig. 1: TZIDC-200 schematic diagram

Basic model

- 1 LKS plug
- 2 Positioning signal 4 ... 20 mA
- 3 Digital input
- 4 Digital output DO
- 5 Supply, 1.4 ... 6 bar (20 ... 90 psi)
- 6 Exhaust
- 7 I/P module with 3/3-way valve
- 8 Position sensor (optional up to 270° rotation angle)

Optional upgrades

- 9 Plug module for analog feedback (4 ... 20 mA)
- 10 Plug-in module for safety shutdown (forced depressurization)
- 11 Plug module for digital feedback
- 12 Installation kit for mechanical position indicator
- 13 Installation kit for digital feedback with proximity switches
- 14 Installation kit for digital feedback with 24 V microswitches



Important

With optional upgrades either the "Installation kit for digital feedback with proximity switches" (13) **or** the "Installation kit for digital feedback with microswitches 24 V" (14) can be used.

2 Mounting versions

2.1 To linear actuators in accordance with the standard

Lateral attachment is in accordance with DIN / IEC 534 (lateral attachment to NAMUR). The required attachment kit is a complete set of attachment material, but does not include the screwed pipe connections and air pipes.

2.2 To rotary actuators in accordance with the standard

This attachment is designed for mounting according to the standard VDI/VDE 3845. The attachment kit consists of a console with mounting screws for mounting on a rotary actuator. The adapter for coupling the positioner feedback shaft to the actuator shaft has to be ordered separately. Screwed pipe connections and air pipes have to be provided on site.

2.3 Integral mounting to control valves

The TZIDC-200 positioner featuring standard pneumatic action is available as an option for integral mounting.

The required holes are found at the back of the device.

The benefit of this design is that the point for mechanical stroke measurement is protected and that the positioner and actuator are linked internally. No external tubing is required.

2.4 Special actuator-specific mounting

In addition to the mounting methods described above, there are special actuator-specific attachments.

Please contact us for details.

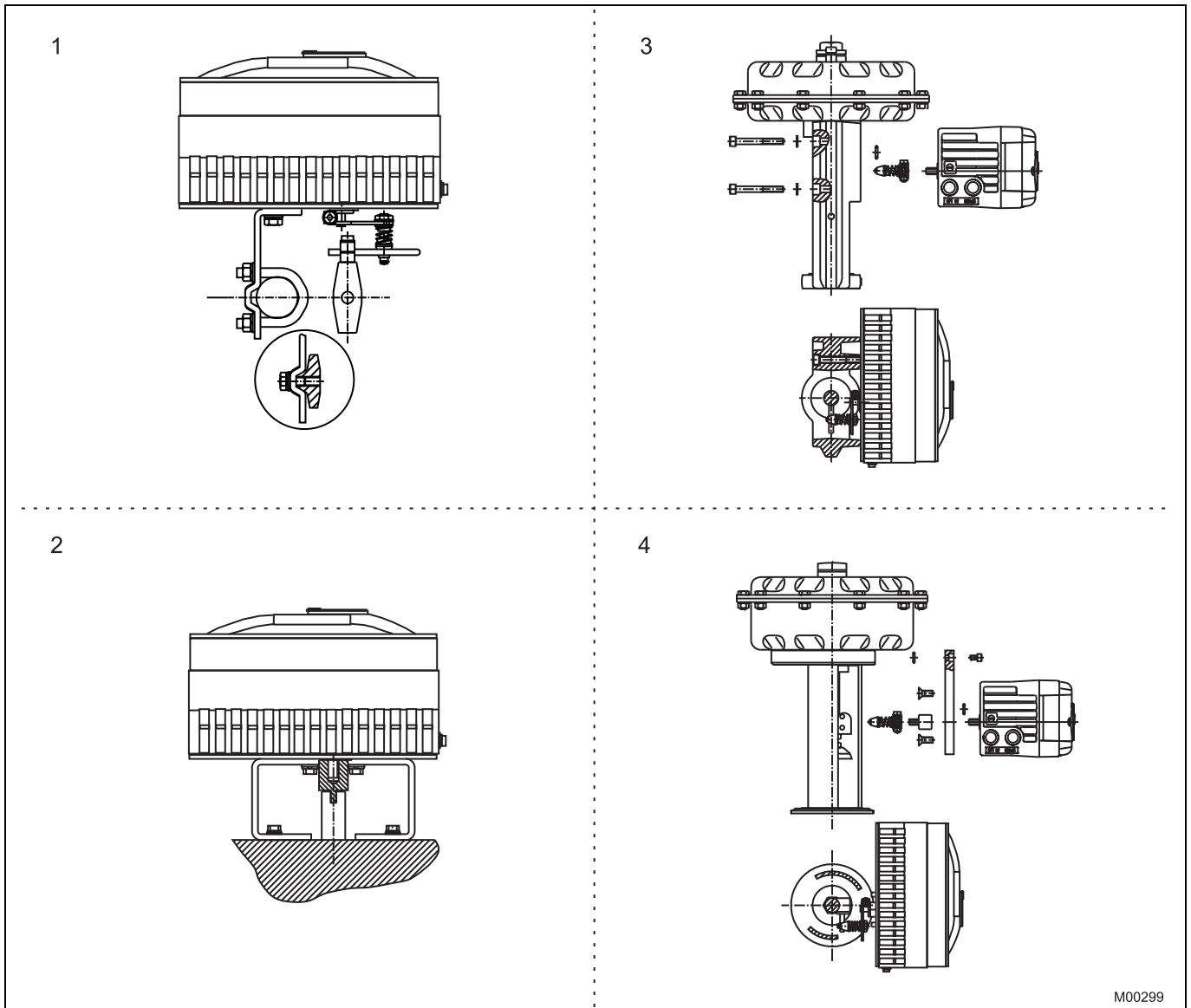

Fig. 2: Mounting options

- 1 Mounting to linear actuators acc. to DIN / IEC 534
- 2 Mounting to rotary actuators to VDI / VDE 3845

- 3 Integral mounting to control valves
- 4 Integral mounting to control valves by using an adapter panel

3 Operation

3.1 General

Microprocessor-based position control in the TZIDC-200 provides for optimal results. The positioner features high-precision control functions and high operational reliability. Due to their elaborate structure and easy accessibility, the device parameters can be quickly adapted to the respective application.

The total range of parameters includes:

- Operating parameters
- Adjustment parameters
- Monitoring parameters
- Diagnosis parameters
- Maintenance parameters

3.1.1 Operating parameters

The following operating parameters can be set manually if required:

Signal

Signal min. 4 mA, max. signal 20 mA (0 ... 100 %)
freely selectable for split-range operation
min. range 20 % (3.2 mA)
recommended range > 50 % (8.0 mA)

Action (positioning signal)

Increasing: Signal 4 ... 20 mA = position 0 ... 100 %
Increasing: Signal 20 ... 4 mA = position 0 ... 100 %

Characteristic curve (travel = f {signal})

Linear, equal percentage 1:25 or 1:50 or 25:1 or 50:1 or freely configurable with 20 reference points.

Travel limit

The positioning travel, i.e. the stroke or angle of rotation, can be reduced as required within the full range of 0 ... 100 %, provided that a minimum value of 20 % is observed.

Shut-off function

This parameter can be set separately for each end position. When the respective configured limit value is exceeded, the shut-off function causes immediate travel of the actuator until reaching the set end position.

When the shut-off value is set to "0", the position is further controlled, even in the respective end position.

Travel time prolongation

This function can be used to increase the max. travel time for full travel. This time parameter can be set separately for each direction.



Important

This function can only be used with the pneumatics with the safety function "fail-safe".

Switching points for the position

This parameter allows you to define two position limits for signaling (see option "Module for digital position feedback").

Digital output

The alarms generated in the TZIDC-200 positioner can be polled via the digital output as a collective alarm.

The desired information can be selected via the operator panel or remotely via the configuration program.

The output can be set to "active high" or "active low", as required.

Digital input

For the digital input, one of the following safety options can be selected. You may use the operator's panel or configuration program to select an option.

- No function (default)
- Move to 0 % position
- Move to 100 % position
- Hold previous position
- disable local configuration
- Disable local configuration and operation
- Disable any access (no local or remote access via a PC)

The selected function is activated once the 24 V DC signal is no longer applied (< 11 V DC).

3.1.2 Adjustment parameters

The TZIDC-200 positioner has a special function for automatic adjustment of the parameters.

Additionally, the control parameters can be set automatically (in adaptive control mode) or manually to optimally adapt them to the process requirements.

Tolerance band

Upon reaching the tolerance band, the position is slowly re-adjusted until the dead band has been reached.

Dead band (sensitivity)

When reaching the dead band, the position is held. The factory setting for this parameter is 0,1 %.

Actuator spring action

Selection of the sensor shaft rotating sense (looking into the open case), if the valve is moved to the safe position by the actuator spring (actuator is depressurized via Y1 / OUT1).

For double-acting actuators the actuator spring action corresponds to pressurizing the pneumatic output (OUT2).

Display 0 ... 100 %

Adjusting the display (0 ... 100%) according to the direction of action for opening or closing the valve.

3.1.3 Monitoring parameters

Various functions for permanent operational monitoring are implemented in the TZIDC-200 operating program. The following states will be detected and indicated, e.g.:

- 4 ... 20 mA signal out of range
- position out of the adjusted range
- positioning time-out (adjustable time parameter)
- position controller inactive
- counter limits (settable in the diagnosis phase) exceeded

While automatic commissioning is in progress, the current state is continuously indicated on the integrated LCD.

During operation, the LCD shows the most important process variables:

- current position (in %),
- malfunctions, alarms, messages (as code)

Access to extended monitoring parameters is possible via HART communication and the DTM.

3.1.4 Diagnosis parameters

The diagnosis parameters of the TZIDC-200 program inform the operator about the operating conditions of the valve.

From this information the operator can derive which maintenance works are required, and when.

Additionally, limit values can be defined for these parameters. When they are exceeded, an alarm is reported.

The following values are e.g. determined:

- Number of movements performed by the valve
- Total travel

The diagnosis parameters and limit values can be called up, set, and reset via HART communication, using the configuration program.

3.2 Operator panel

The TZIDC-200 positioner's operator panel with four pushbuttons allows for

- operational monitoring
- manual control
- configuration
- fully automatic commissioning

The operator panel is protected by a hinged cover which can be opened during operation even in hazardous areas, i.e. the positioner can be locally operated any time as required.

3.2.1 Single-button commissioning

Commissioning the TZIDC-200 positioner is especially easy. The standard Autoadjust function for automatic adaptation of the device parameters can be started by simply pressing a single front panel button, and without knowing parameterization details.

Depending on the selected actuator type (linear or rotary), the displayed zero position is automatically adapted:

- for linear actuators counter-clockwise (CTCLOCKW)
- for rotary actuators clockwise (CLOCKW).

Besides this standard function, a customized "Autoadjust" function is available. The function is launched either via the operator's panel or HART communication.

3.2.2 Display

The information indicated by the 2-line LC display is permanently updated and adapted during operation, to inform the operator in an optimal way.

During control operation (control with or without adaptation) the following TZIDC-200 data can be called up by pressing the pushbuttons briefly:

- Up button: Current setpoint (mA)
- Down button: Temperature in device
- Up + Down buttons: Current control deviation



Fig. 3: TZIDC-200 with removed cover, view of the operator panel

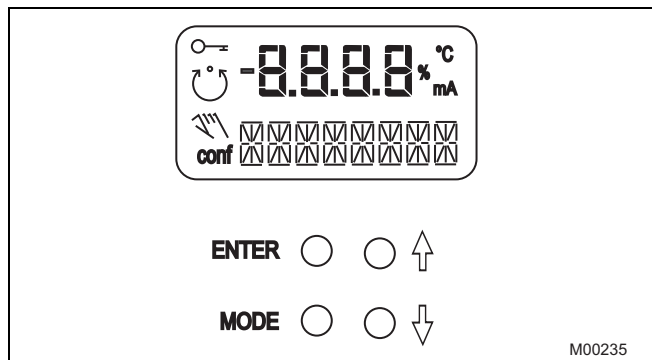

Fig. 4: TZIDC-200 operating elements and display

5 Specifications

5.1 Input

Output signal (two-wire technology)

Nominal range	4 ... 20 mA
Split range configuration between	20 ... 100 % of the nominal range
Max.	50 mA
Min.	3.6 mA
Starting at	3.8 mA
Load voltage at 20 mA	9.7 V
Impedance at 20 mA	485 Ω

Digital input

Control voltage	0 ... 5 V DC logical switching state "0" 11 ... 30 V DC logical switching state "1"
Current	max. 4 mA

5.2 Output

Compressed air output

Range	0 ... 6 bar (0 ... 90 psi)
Air capacity	5.0 kg/h = 3.9 Nm ³ /h = 2.3 sfc at 1.4 bar (20 psi) supply pressure 13 kg/h = 10 Nm ³ /h = 6.0 sfc at 6 bar (90 psi) supply pressure
Output function	For single or double-acting actuators, air is vented from actuator or actuator is blocked in case of (electrical) power failure
Shut-off values	End position 0 % = 0 ... 45 % End position 100 % = 55 ... 100 %

Digital output (control circuit to DIN 19234 / NAMUR)

Supply voltage	5 ... 11 V DC
Current > 0.35 mA ... < 1.2 mA	Switching state logical "0"
Current > 2.1 mA	Switching state logical "1"
Effective direction (configurable)	normally logical "0" or logical "1"

5.3 Travel

Rotation angle

Used range	25 ... 120° (rotary actuators, optional 270°) 25 ... 60° (linear actuators)
Travel limit	Min. and max. limits, freely configurable between 0 ... 100 % of total travel (min. range > 20 %)
Travel time prolongation	Range of 0 ... 200 s, separately for each direction
Dead band time limit	Setting range 0 ... 200 s (monitoring parameter for control until the deviation reaches the dead band)

5.4 Air supply

Instrument air

free of oil, water and dust acc. to DIN / ISO 8573-1
pollution and oil content according to Class 3 (purity: max. particle size: 5 µm, max. particle density: 5 mg / m³; oil content: max. concentration: 1 mg / m³; pressure dew point: 10 K below operating temperature)

Supply pressure

1.4 ... 6 bar (20 ... 90 psi)

Note: Do not exceed the max. operating pressure of the actuator!

Air consumption

< 0.1 kg/h / 0.05 scfm (independent of supply pressure)

5.5 Transmission data and influences

Output Y1

Increasing	Increasing output signal 0 ... 100 % Increasing pressure at output
Decreasing	Increasing output signal 0 ... 100 % Decreasing pressure at output

Action (output signal)

Increasing	Signal 4 ... 20 mA = actuator position 0 ... 100 %
Decreasing	Signal 20 ... 4 mA = actuator position 0 ... 100 %

Characteristic curve (travel = f {signal})

Linear, equal percentage 1:25 or 1:50 or 25:1 or 50:1 and freely configurable with 20 reference points.

Deviation	≤ 0,5 %
Tolerance band	0.3 ... 10 %, adjustable
Dead band	0.1 ... 10 %, adjustable
Resolution (A/D conversion)	> 16000 steps
Sample rate	20 ms
Influence of ambient temperature	≤ 0.5 % per 10 K
Influence of vibration	≤ 1 % to 10 g and 80 Hz

Seismic vibration

Meets requirements of DIN / IEC 68-3-3 Class III for strong and strongest earthquakes.

Influence of mounting orientation

Not measurable.

Complies with the following directives

- EMC Directive 2004/108/EC as of December 2004
- EC Directive for CE conformity marking

Communication

- HART Protocol 5.9
- Local connector for LKS (not in Ex area)
- HART communication via 20 mA signal line with (optional) FSK modem

5.6 Environmental capabilities

Ambient temperature

For operation, storage and transport: -40 ... 85 °C (-40 ... 185 °F)
When using proximity switches
SJ2-S1N (NO): -25 ... 85 °C (-13 ... 185 °F)

Relative humidity

Operational (with closed housing
and air supply switched on): 95 % (annual average),
condensation permissible
Transport and storage: 75 % (annual average), non-
condensing

5.7 Housing

Material/Ingress protection

Aluminum, protection class IP 65 / NEMA 4X

Surface/color

Electrostatic dipping varnish with epoxy resin, stove-hardened. Case
varnished black, RAL 9005, matte, housing cover Pantone 420.

Electrical connections

Screw terminals: Max. 1.0 mm² for options,
Max. 2.5 mm² for analog signal.

Note: Do not expose the terminals to strain.

Cable entry: 2 tap holes 1/2-14 NPT or
M20 x 1.5 (cable gland or pipe plug must be
ordered separately)

Pneumatic connections

Threads G 1/4 or 1/4-18 NPT

Weight

3,0 kg (1,36 lb)

Mounting orientation

Any

Dimensions

See "Dimensions"

5.8 Safety Integrity Level



Important

Applies to applications with single-acting and depressurizing
pneumatics.

The positioner TZIDC / TZIDC-200 and the emergency shutdown
module for meet the requirements regarding:

- functional safety acc. to IEC 61508
- explosion protection (depending on the model)
- electromagnetic compatibility in accordance with EN 61000

Without the input signal, the pneumatic module in the positioner vents
the drive and the installed spring in it moves the valve in a
predetermined end position (OPEN or CLOSED).

SIL specific safety-related characteristics:

Device	SFF	PFDav	$\lambda_{dd} + \lambda_s$	λ_{du}
TZIDC / TZIDC-200 as shutdown module	94 %	$1.76 * 10^{-4}$	718 FIT	40 FIT
TZIDC / TZIDC-200 with supply current 0 mA	94 %	$1.76 * 10^{-4}$	651 FIT	40 FIT

For details refer to the Management Summary in the SIL-Safety
Instructions 37/18-79XA.

5.9 Explosion protection

FM Approval HLC 8/02 3010829

Explosion Proof; enclosure 4X; T5, max. 82 °C
CL I; Div 1; Grp. C-D

Intrinsic Safety; enclosure 4X; T5, max. 82 °C
CL I, II, III; Div 1; Grp. A-B-C-D-E-F-G

Non-Incendive; enclosure 4X; T4, max. 85 °C
CL I; Div 2; Grp. A-B-C-D
CL II, III; Div 2; Grp. F-G

Dust-Ignition Proof; enclosure 4X; T5, max. 82 °C
CL II, III; Div 1; Grp. E-F-G

CSA Certification 1393920

Explosion Proof; enclosure 4X; T5, max. 85 °C
CL I; Div 1; Grp. C-D
CL II; Div 1; Grp. E-F-G
CL III

Intrinsic Safety; enclosure 4X; T5, max. 82 °C
CL I; Div 1; Grp. A-B-C-D
CL II; Div 1; Grp. E-F-G
CL III

ATEX / GOST Russia / GOST Ukraine II 2G EEx d II C T4/T5/T6

Type-Examination Test Certificate: DMT 02 ATEX E 029 X
Type: **Flameproof enclosure**
Device class: II 2G (EEx ib IIC)
Temperature class: T4, T5, T6
Permissible ambient temperature: T4: -40 °C < T_{amb} < 85 °C
T5: -40 °C < T_{amb} < 80 °C
T6: -40 °C < T_{amb} < 65 °C

ATEX II 2G EEx ib IIC T6

Type-Examination Test Certificate: TÜV 98 ATEX 1370 X
Type: **Intrinsically safe equipment**
Device class: II 2G (EEx ib IIC)
Temperature class: T4, T5, T6
Permissible ambient temperature: T4: -40 °C < T_{amb} < 85 °C
T5: -40 °C < T_{amb} < 50 °C
T6: -40 °C < T_{amb} < 35 °C

IECEX Ex ib IIC T6

Type-Examination Test Certificate: IECEX TUN 04.0015X, Issue no.: 4
Type: **Intrinsic safety**
Temperature class: T4, T5, T6
Permissible ambient temperature: T4: -40 °C < T_{amb} < 85 °C
T5: -40 °C < T_{amb} < 50 °C
T6: -40 °C < T_{amb} < 40 °C

IECEX Ex d
Type-Examination Test Certificate: IECEX BVS 07.0030X, Issue No.: 0
Type: **Flameproof enclosures 'd'**
Temperature class: T4, T5, T6
Permissible ambient temperature: T4: -40 °C < T_{amb} < 85 °C
T5: -40 °C < T_{amb} < 80 °C
T6: -40 °C < T_{amb} < 65 °C

5.10 Options

Module for analog position feedback¹⁾

Signal range 4 ... 20 mA (configurable split ranges)
Supply, 2-wire circuitry 24 V DC (10 ... 30 V DC)
48 V DC (20 ... 48 V DC, no ignition protection)
Characteristic curve (configurable) Rising or falling
Deviation < 1 %



Important

Without a signal from the positioner (e.g., "no energy" or "initializing") the module sets the output to > 20 mA (alarm level).

Module for digital position feedback¹⁾

Two switches for digital position feedback (position adjustable within the range of 0 ... 100%, ranges cannot overlap)
Current circuits acc. to DIN 19234 / NAMUR
Supply voltage 5 ... 11 V DC
Signal current < 1.2 mA Switching state logical "0"
Signal current > 2.1 mA Switching state logical "1"
Direction of action normally logical "0" or logical "1" (configurable)

Module for the emergency shutdown function²⁾

Supply voltage 24 V DC (20 ... 30 V DC) (electrically isolated from input signal)
Safe position is activated when Voltage < 5 V
Explosion protection see certificate (operating instructions)
SIL See "Safety Integrity Level"

A separate 24 V DC signal is normally applied to the emergency shutdown module, which connects through the signal from the microprocessor to the I/P module. When the 24 V DC signal is interrupted, the pneumatic module executes the respective safety function, depending on the mechanical construction:

The positioner output 1 is depressurized, and the valve is moved to the safe position. In case of a double-acting actuator the second output 2 is additionally pressurized.

6 Electrical connections

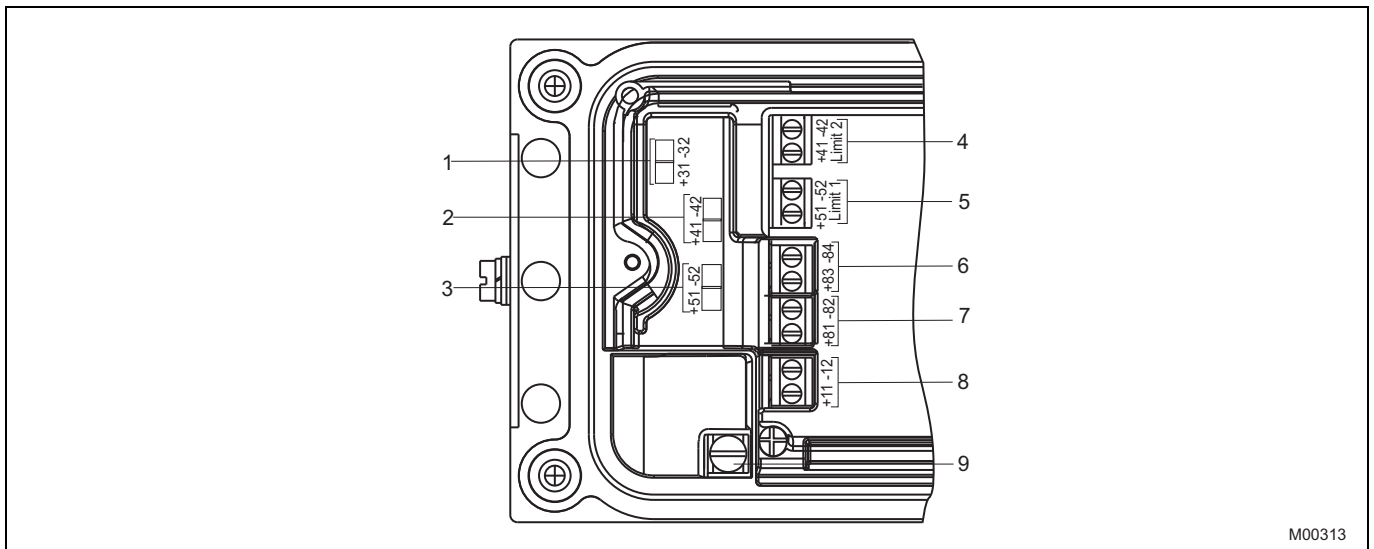

Fig. 7: Screw terminals, overview

- | | | | |
|---|--|---|--|
| 1 | Module for analog position feedback | 5 | Digital position feedback, either proximity switches or 24 V microswitches |
| 2 | Module for digital feedback or service switch of emergency shutdown module | 6 | Digital output DO |
| 3 | Module for digital feedback or terminals for emergency shutdown module | 7 | Digital input |
| 4 | Digital position feedback, either proximity switches or 24 V microswitches | 8 | Signal 4 ... 20 mA |
| | | 9 | Grounding screw |

M00313

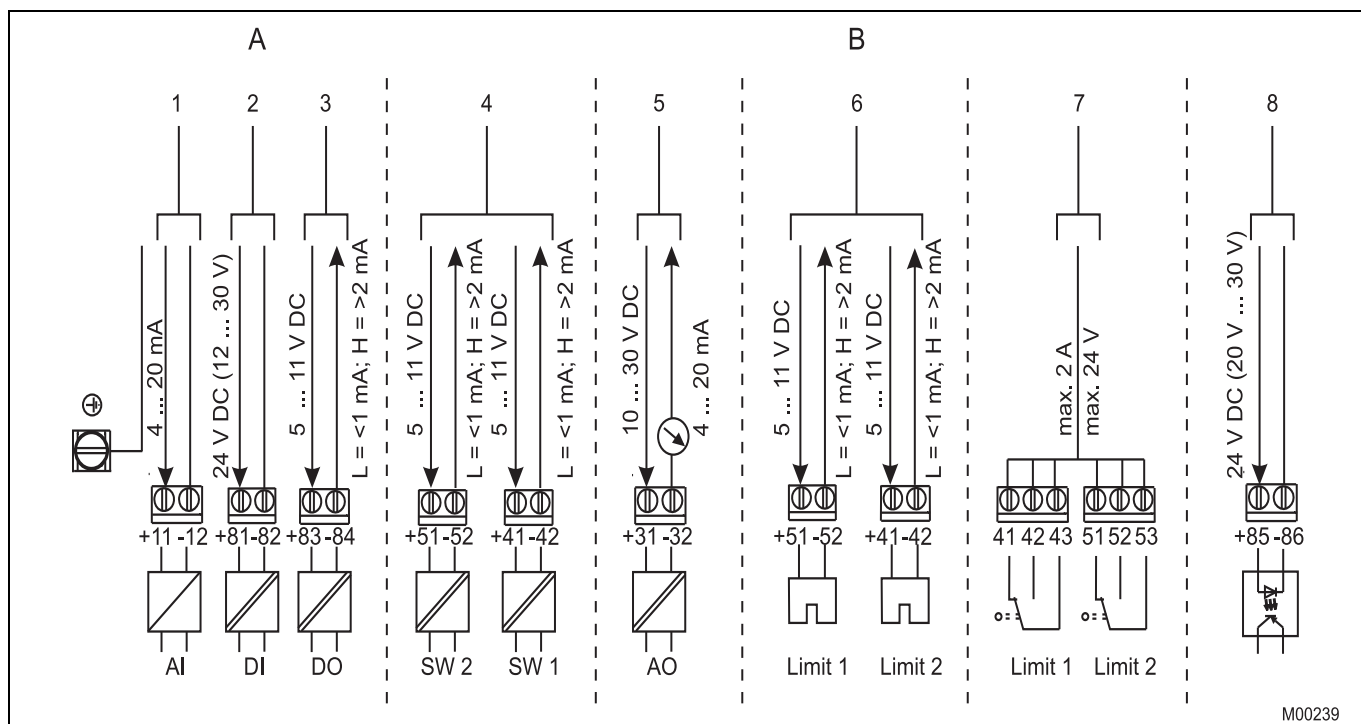

Fig. 8: Pin configuration

A Basic model
 B Options

- 1 Analog input
- 2 Digital input
- 3 Digital output DO
- 4 Digital feedback
- 5 Analog feedback
- 6 Proximity switches
- 7 Microswitches
- 8 Emergency shutdown module

7 Dimensions

All dimensions in mm (inch)

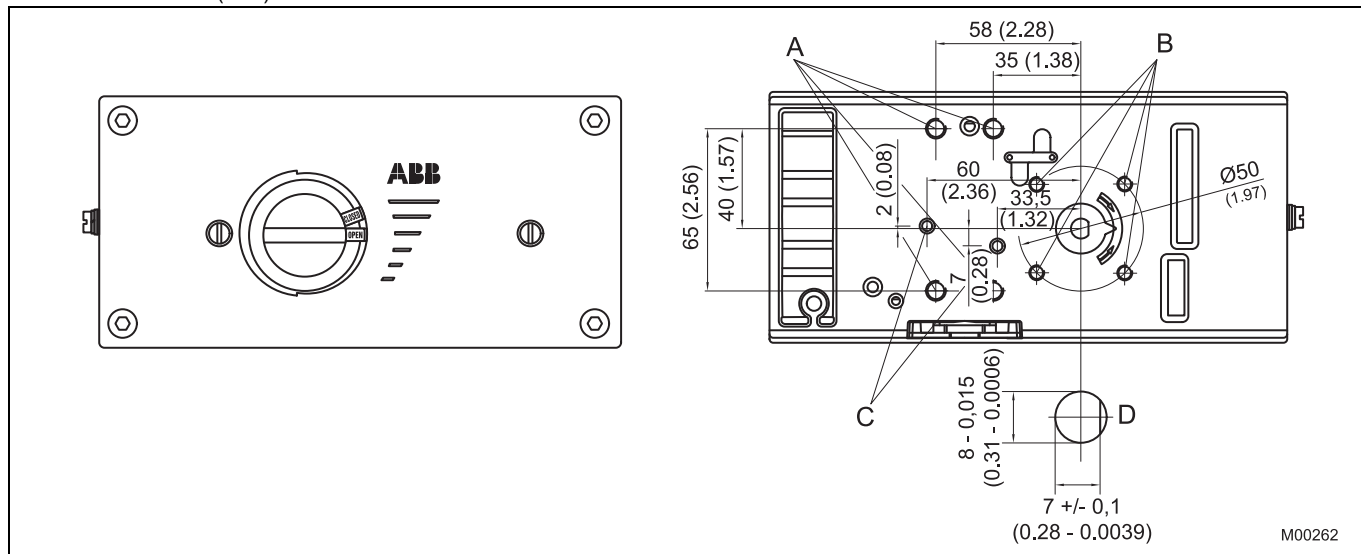

Fig. 9: Top view

- A Tap hole M8 (10 mm (0.39 inch) low)
- B Tap hole M6 (8 mm (0.32 inch) low)

- C Tap hole M5 x 0.5 (air connections in version for integral mounting)
- D Sensor shaft (larger than scale)

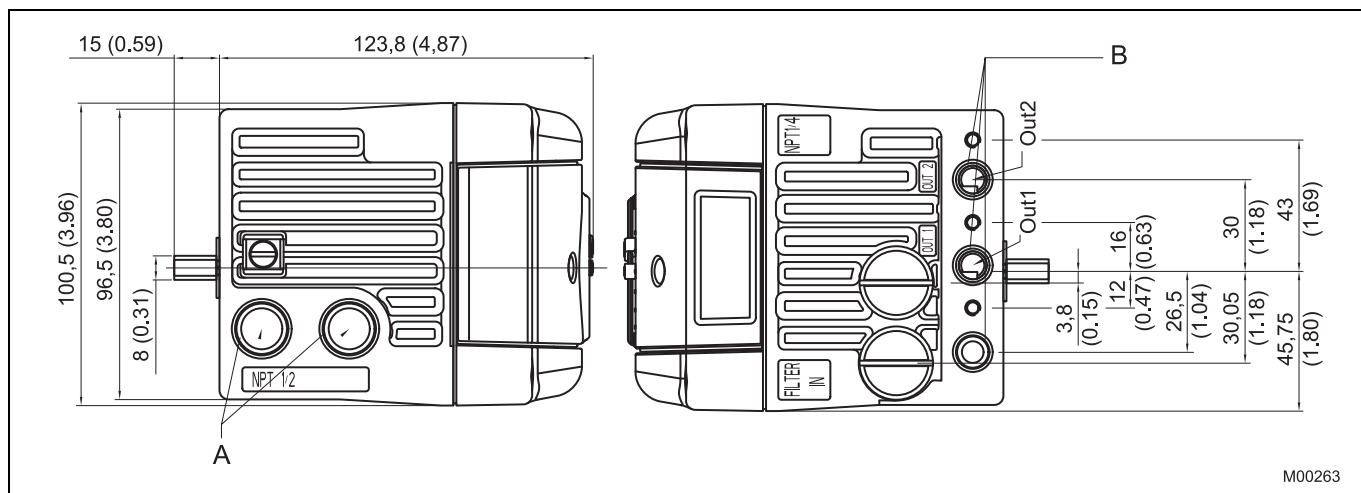

Fig. 10: Left and right side view

- A NPT 1/2" or M20 x 1.5

- B Pneumatic connections, NPT 1/4" -18 or G1/4"

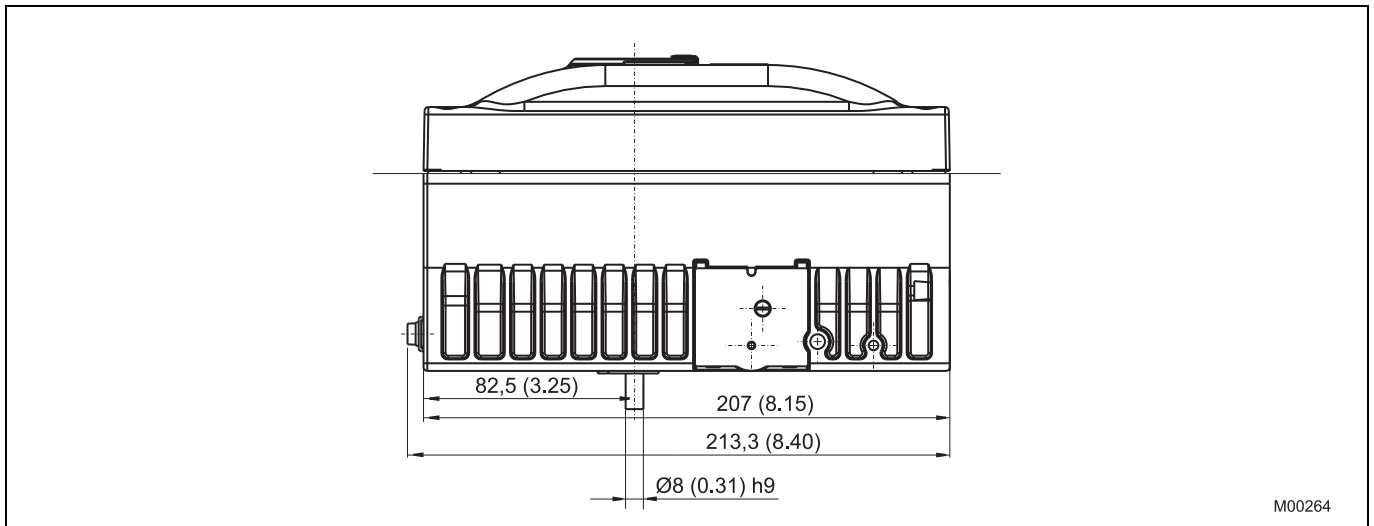
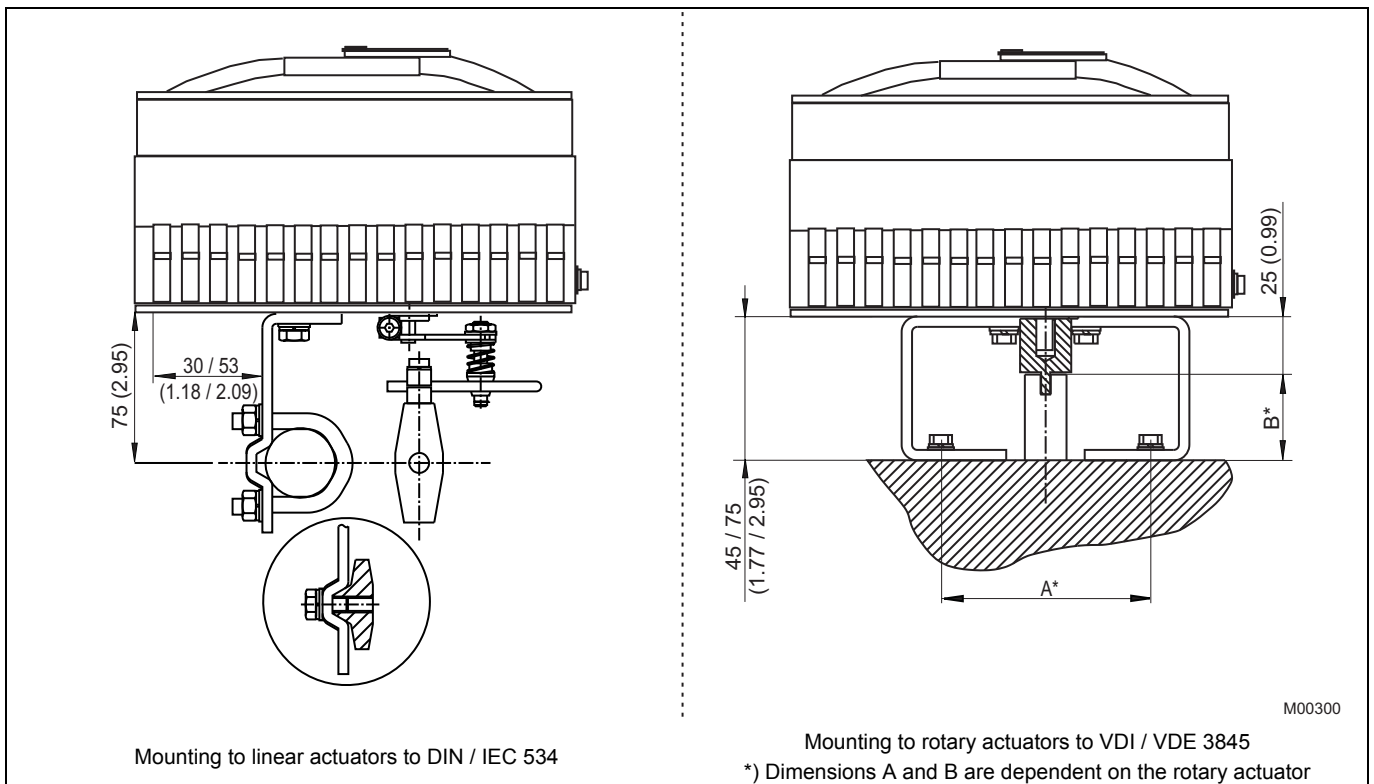

Fig. 11: Bottom view

A Pneumatic connections, NPT 1/4"-18 or G1/4"



Mounting to linear actuators to DIN / IEC 534

Mounting to rotary actuators to VDI / VDE 3845

*) Dimensions A and B are dependent on the rotary actuator

Fig. 12: Mounting drawings

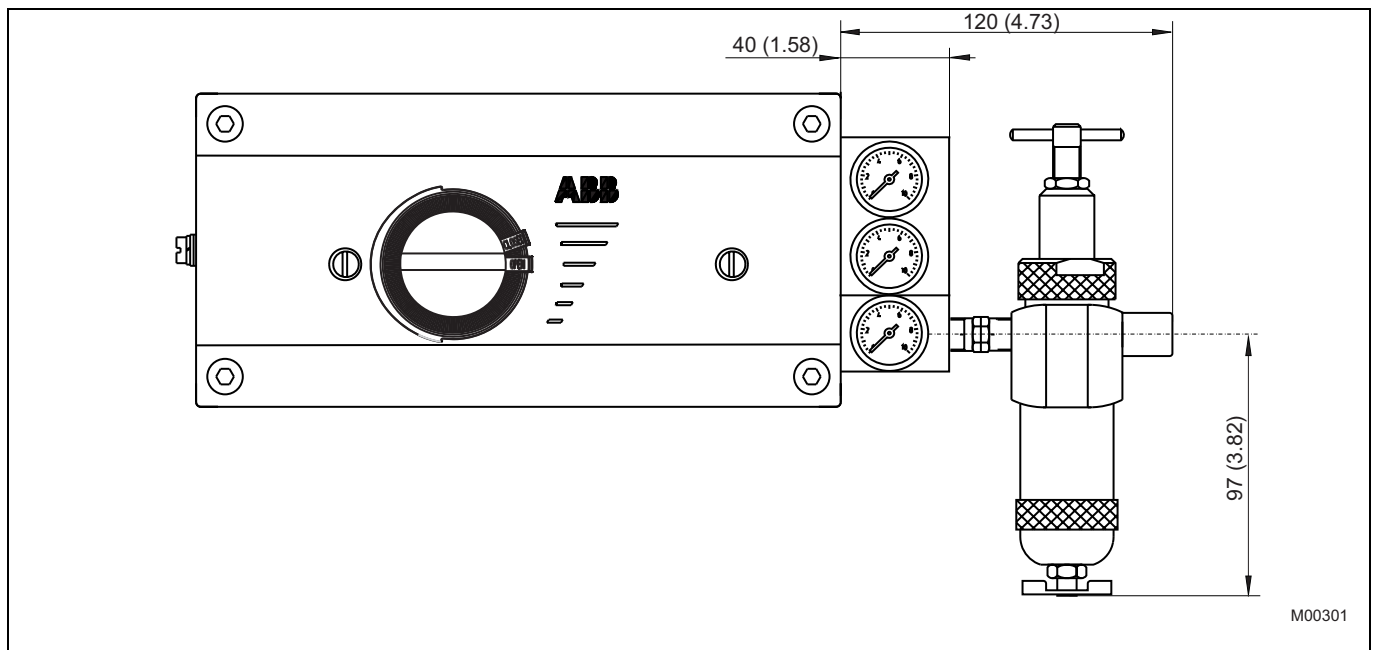

Fig. 13: Positioner TZIDC-200 with pressure gauge block and filter regulator

8 Ordering information

	Main Code											Add. Code				
	Variant digit No	1	2	3	4	5	6	7	8	9	10					
TZIDC-200 Electro-Pneumatic Positioner, with Flameproof Enclosure, intelligent, software-configurable with Local Communication Interface (LKS) and HART communication	V18348	X	X	X	X	X	X	X	X	X	X	X	X	X	X	XXX
Case / Mounting																
Case made of aluminium, varnished, for mounting to linear actuators acc. to DIN/IEC 534 / NAMUR or to rotary actuators acc. to VDI/VDE 3845		1	0													
Case made of aluminium, varnished, with mechanical position indicator, for mounting to linear actuators acc. to DIN/IEC 534 / NAMUR or to rotary actuators acc. to VDI/VDE 3845		2	0													
Case made of aluminium, varnished, for integral mounting to control valves		3	0													
Case made of aluminium, varnished, with mechanical position indicator, for integral mounting to control valves		4	0													
Case made of aluminium, varnished, for mounting to rotary actuators acc. to VDI/VDE 3845 with extended rotation angle up to 270°		5	0													
Case made of aluminium, varnished, with mechanical position indicator, for mounting to rotary actuators acc. to VDI/VDE 3845 with extended rotation angle up to 270°		6	0													
Operation																
With operator panel and display integrated in the enclosure cover																
Explosion Protection																
ATEX Ex II 2 G EEx d IIC T4, T5, T6																
FM / CSA Class 1, Div. 1, Group C-D (explosion-proof)																
ATEX EEx ib and EEx d IIC T6																
FM / CSA intrinsically Safe und explosion-proof																
IECEX Ex ib IIC T6																
IECEX Ex d IIC T4, T5, T6																
GOST Russia Ex d IIC T4/T5/T6																
Output / Safe Position (in case of an electrical power failure)																
Single acting, fail safe																
Single acting, fail freeze																
Double acting, fail safe																
Double acting, fail freeze																
Connections																
Cable: thread M20 x 1.5, air pipe: thread G 1/4																
Cable: thread M20 x 1.5, air pipe: thread 1/4-18 NPT																
Cable: thread 1/2-14 NPT, air pipe: thread 1/4-18 NPT																

1) Only with cable connection NPT thread

Continued on next page

	Main Code													Add. Code
	Variant digit No	1 – 6	7	8	9	10	11	12	13	14	15	16	17	
TZIDC-200 Electro-Pneumatic Positioner, with Flameproof Enclosure, intelligent, software-configurable with Local Communication Interface (LKS) and HART communication	V18348	X	X	X	X	X	X	X	X	X	X	X	X	XXX
Option Modules for Analog or Digital Position Feedback														
Without										0				
Plug-in module for analog position feedback, signal range 4 ... 20 mA, two-wire										1				
Plug-in module for digital position feedback										3				
Plug-in module for analog position feedback, signal range 4 ... 20 mA, two-wire, and digital position feedback										4				
Plug-in module for shutdown module								2)	5					
Analog feedback and shut-down								2)	6					
Optional Mechanical Kit for Digital Position Feedback														
Without										0				
Mechanical kit for digital position feedback with proximity switches SJ2-SN (NC or logical 1) (NC or logical 1)										1				
Mechanical kit for digital position feedback with proximity switches SJ2-S1N (NO or logical 0)								6)	2					
Mechanical kit for digital position feedback with 24 V AC / DC microswitches (change-over contacts)								3)	3					
Parameter Setting / Bus Address														
Factory setting for HART devices													1	
Customized parameter setting for HART devices													2	
Design (Varnish / Coding)														
Standard													1	
Others													2	
Device Identification Label														
Without													0	
Label													4)	1
Label including text, with separate stainless steel label 11.5 x 60 mm (0.45 x 2.36 in.)													4)	2
SIL2 - Declaration of Conformity														
SIL2 - Declaration of Conformity													5)	CS2
Certificate of Compliance														
Certificate of compliance with the order acc. to EN 10204-2.1 (DIN 50049-2.1)														CF1
Certificate of compliance with the order acc. to EN 10204-2.1 (DIN 50049-2.1) with item description														CF2
Test report acc. to EN 10204-2.2 (DIN 50049-2.2)														CF3
Inspection Certificate														
Inspection certificate 3.1 acc. to EN 10204 with max. deviation														CBA

- 2) Only for fail safe pneumatic, Not for FM / CSA Version
- 3) Only for Ex d version
- 4) (Plain text, max. 16 letters)
- 5) Not with Ex protection and with single acting fail safe pneumatic only
- 6) Only for ambient temperature range -25 ... 85 °C

8.1 Accessories

Description	Order number
TZIDC Attachment kit for linear actuators, stroke 10 ... 35 mm	7959125
TZIDC Attachment kit for linear actuators, stroke 20 ... 100 mm	7959126
TZIDC Lever 30 mm	7959151
TZIDC Lever 100 mm	7959152
TZIDC Adapter (shaft coupler) for rotary actuators (mounting to VDI / VDE 3845)	7959110
TZIDC Pressure gauge block, for single acting TZIDC, 0 ... 4 bar (0 ... 60 psi), G 1/4 connections	7959111
TZIDC Pressure gauge block, for single acting TZIDC, 0 ... 10 bar (0 ... 140 psi), G 1/4 connections	7959112
TZIDC Pressure gauge block, for single acting TZIDC, 0 ... 4 bar (0 ... 60 psi), 1/4-18 NPT connections	7959113
TZIDC Pressure gauge block, for single acting TZIDC, 0 ... 10 bar (0 ... 140 psi), 1/4-18 NPT connections	7959114
TZIDC Pressure gauge block, for double acting TZIDC, 0 ... 4 bar (0 ... 60 psi), G 1/4 connections	7959115
TZIDC Pressure gauge block, for double acting TZIDC, 0 ... 10 bar (0 ... 140 psi), G 1/4 connections	7959116
TZIDC Pressure gauge block, for double acting TZIDC, 0 ... 4 bar (0 ... 60 psi), 1/4-18 NPT connections	7959117
TZIDC Pressure gauge block, for double acting TZIDC, 0 ... 10 bar (0 ... 140 psi), 1/4-18 NPT connections	7959118
TZIDC Filter regulator, brass, connections thread G 1/4, incl. material for mounting to pressure gauge block	7959119
TZIDC Filter regulator, brass, connections thread 1/4-18 NPT, incl. material for mounting to pressure gauge block	7959120
TZIDC Attachment kit for Badger Meter ATC 754/755	7959123
TZIDC Attachment kit for Fisher 1051-30, 1052-30	7959214
TZIDC Attachment kit for Fisher 1061 size 130	7959206
TZIDC Attachment kit for Fisher 471	7959195
TZIDC Attachment kit for Fisher 585 C	7959250
TZIDC Attachment kit for Fisher 657 / 667 Size 10 ... 30 mm	7959177
TZIDC Attachment kit for GEMÜ 690/25 and 50	7959103
TZIDC Attachment kit for Guide DK	7959161
TZIDC Attachment kit for Keystone 79U/E-002(S) ... 79U/E-181(S)	7959147
TZIDC Attachment kit for Masoneilan CAMFLEX II, VARIMAX, MINITORK II	7959144
TZIDC Attachment kit for Masoneilan VariPak 28000 series	7959163
TZIDC Attachment kit for MaxFlo MaxFlo	7959140
TZIDC Attachment kit for NAF 791290	7959207
TZIDC Attachment kit for NAMUR stroke 100 ... 170 mm	7959339
TZIDC Attachment kit for NELES BC6-20, B1C6-20, BJ8-20, B1J8-20	7959146
TZIDC Attachment kit for Valves Nuovo Pignone, lever for linear stroke, length 150 ... 250 mm	7959210
TZIDC Attachment kit for linear actuators, stroke 10 ... 35 mm	7959181
TZIDC Attachment kit for Valves Nuovo Pignone, pressure gauge block with 2 manometers, material stainless steel	7959145
TZIDC Attachment kit for Samson 241, 271, 3271	7959136
TZIDC Attachment kit for Samson 3277	7959200
TZIDC Attachment kit for Schubert&Salzer GS 8020 / 8021 / 8023	7959141
TZIDC Attachment kit for SED SED stroke 100 mm	7959244
TZIDC-2xx 1 x EEx d cable gland M20 x 1.5, 1 pipe plug M20 x 1.5, securing adhesive	7959245
TZIDC-2xx 2 x EEx d cable glands M20 x 1.5, securing adhesive	7959246
TZIDC-2xx 1 x EEx d cable gland 1/2 in. NPT, 1 pipe plug 1/2 in. NPT, securing adhesive	7959247

Contact us

ABB Ltd.

Process Automation

Salterbeck Trading Estate
Workington, Cumbria
CA14 5DS
UK

Phone: +44 (0)1946 830 611

Fax: +44 (0)1946 832 661

ABB Inc.

Process Automation

125 E. County Line Road
Warminster, PA 18974
USA

Phone: +1 215 674 6000

Fax: +1 215 674 7183

ABB Automation Products GmbH

Process Automation

Schillerstr. 72
32425 Minden
Germany

Phone: +49 551 905-534

Fax: +49 551 905-555

www.abb.com

Note

We reserve the right to make technical changes or modify the contents of this document without prior notice. With regard to purchase orders, the agreed particulars shall prevail. ABB does not accept any responsibility whatsoever for potential errors or possible lack of information in this document.

We reserve all rights in this document and in the subject matter and illustrations contained therein. Any reproduction, disclosure to third parties or utilization of its contents - in whole or in parts - is forbidden without prior written consent of ABB.

Copyright© 2010 ABB

All rights reserved