

for air, test benches



Thermal Mass Flowmeter Sensyflow FMT700-P

Operating Instruction

42/14-42-EN

12.2011

Rev. D

Translation of the original instruction

Manufacturer:

**ABB Automation Products GmbH
Process Automation**

Dransfelder Straße 2
D-37079 Göttingen
Germany
Tel.: +49 551 905-534
Fax: +49 551 905-555

Customer service center

Phone: +49 180 5 222 580
Fax: +49 621 381 931-29031
automation.service@de.abb.com

© Copyright 2011 by ABB Automation Products GmbH
Subject to changes without notice

This document is protected by copyright. It assists the user in safe and efficient operation of the device. The contents of this document, whether whole or in part, may not be copied or reproduced without prior approval by the copyright holder.

1	Safety	4
1.1	Intended use.....	4
1.2	Target groups and qualifications.....	4
1.3	Warranty provisions.....	4
1.4	Note symbols.....	5
1.5	Name plates.....	5
1.6	Safety instructions for electrical installation.....	6
1.7	Returning devices.....	6
1.8	Integrated management system.....	7
1.9	Disposal.....	7
1.9.1	Information on WEEE Directive 2002/96/EC (Waste Electrical and Electronic Equipment).....	7
1.9.2	RoHS Directive 2002/95/EC.....	7
2	Device description	8
2.1	Front view.....	8
2.2	Rear view.....	8
2.2.1	Supply power.....	9
2.2.2	D-SUB connector.....	9
2.2.3	BNC outputs and sensor connection.....	10
3	Electrical connections	11
3.1	BNC outputs and flowmeter sensor connection.....	11
3.2	SLOT 1: D-SUB connection „Serial Output“.....	11
3.3	SLOT 3: D-SUB connection „Totalizer“.....	12
3.4	SLOT 4: D-SUB connection „Analog Outputs“.....	13
4	Commissioning	15
5	Operation	16
5.1	Supply / evaluation unit.....	16
5.2	Display unit (Display).....	17
5.3	Options.....	17
5.3.1	Adjustable measuring rate.....	17
5.3.2	Fast measuring rate.....	18
5.3.3	Analog outputs.....	19
5.4	Temperature measurement.....	21
5.5	Operation with two flowmeter sensors.....	22
6	Communication	23
6.1	Digital interfaces.....	23
6.1.1	Serial interface.....	23
6.1.2	Totalizer (integrator function).....	29
7	Measuring setup and installation	32
8	Specifications	34
9	Dimensions	36
9.1	Flowmeter sensor Sensyflow FMT700-P, DN 25.....	36
9.2	Flowmeter sensor Sensyflow FMT700-P, DN 50 ... DN 200.....	37
9.3	Supply / evaluation unit.....	38
9.4	Accessories.....	38
10	Appendix	45
10.1	Decommissioning and packaging.....	45
10.2	Other applicable documents.....	45
10.3	Approvals and certifications.....	45
10.4	Declaration of conformity.....	46

1 Safety

You must read these instructions carefully prior to installing and commissioning the device. These instructions are an important part of the product and must be kept for future reference. These instructions are intended as an overview and do not contain detailed information on all designs for this product or every possible aspect of installation, operation and maintenance.

For additional information or if specific problems occur that are not discussed in these instructions, contact the manufacturer.

The content of these instructions is neither part of any previous or existing agreement, promise or legal relationship nor is it intended to change the same.

This product is built based on state-of-the-art technology and is operationally safe. It has been tested and left the factory in perfect working order from a safety perspective. The information in the manual must be observed and followed in order to maintain this state throughout the period of operation.

Modifications and repairs to the product may only be performed if expressly permitted by these instructions.

Only by observing all of the safety instructions and all safety/warning symbols in these instructions can optimum protection of both personnel and the environment, as well as safe and fault-free operation of the device, be ensured.

Information and symbols directly on the product must be observed. They may not be removed and must be fully legible at all times.

1.1 Intended use

Mass flow measurement of air in closed pipelines.

The device is designed for use exclusively within the values stated on the name plate and in the technical specifications (see the section titled "Specifications").

1.2 Target groups and qualifications

Installation, commissioning, and maintenance of the product may only be performed by trained specialist personnel who have been authorized by the plant operator accordingly. The specialist personnel must have read and understood the manual and must comply with its instructions.

The operating company must strictly observe the applicable national regulations relating to the installation, function testing, repair, and maintenance of electrical products.

1.3 Warranty provisions

Using the device in a manner that does not fall within the scope of its intended use, disregarding this instruction, using underqualified personnel, or making unauthorized alterations releases the manufacturer from liability for any resulting damage. This renders the manufacturer's warranty null and void.

1.4 Note symbols



IMPORTANT (NOTE)

This symbol indicates operator tips, particularly useful information, or important information about the product or its further uses. It does not indicate a dangerous or damaging situation.

1.5 Name plates

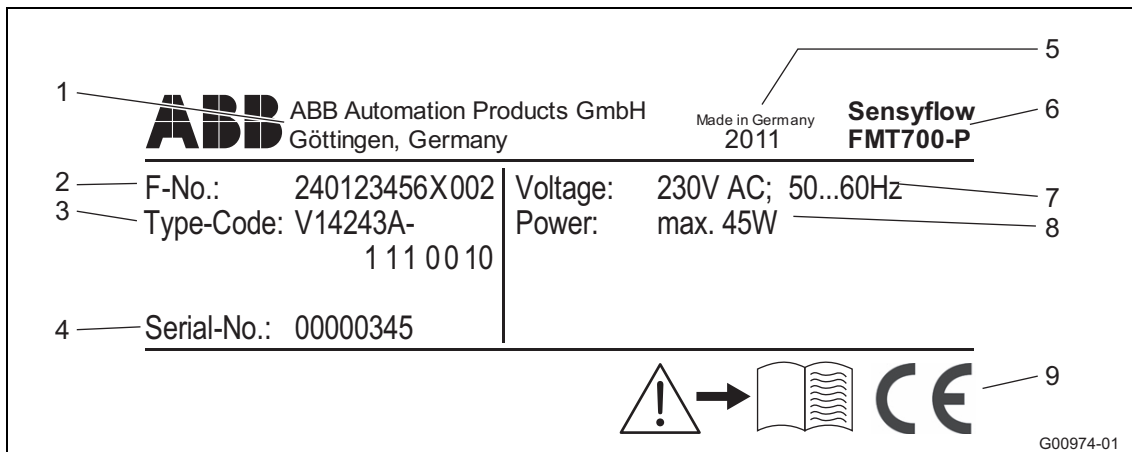

Fig. 1: Name plate, evaluation unit

- | | |
|-----------------------------------------------|-----------------------------|
| 1 Manufacturer | 6 Full name of model |
| 2 Serial number | 7 Power supply |
| 3 Order code | 8 Maximum power consumption |
| 4 Serial number | 9 CE mark |
| 5 Year of manufacture, country of manufacture | |

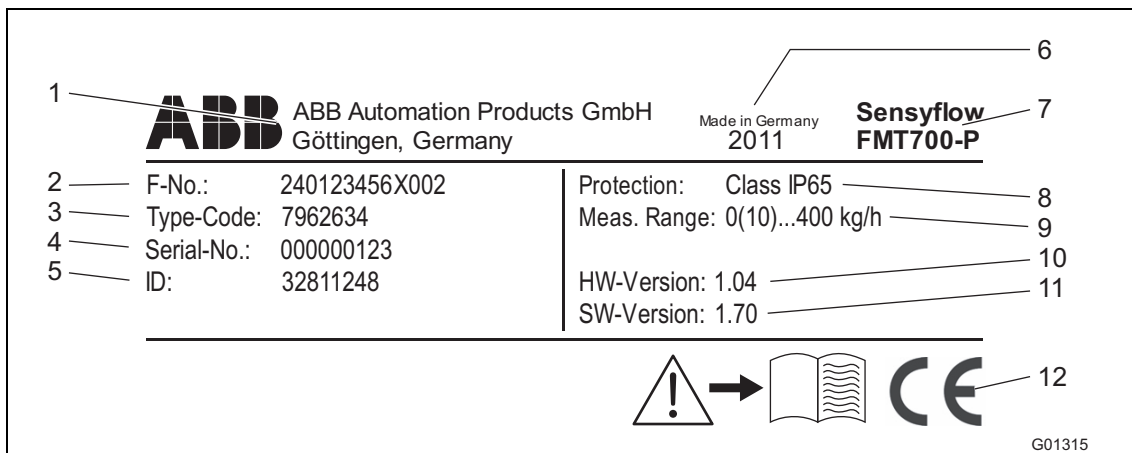

Fig. 2: Name plate, flowmeter sensor

- | | |
|-----------------------------------------------|----------------------|
| 1 Manufacturer | 7 Full name of model |
| 2 Serial number | 8 Protection class |
| 3 Order code (order number) | 9 Measuring range |
| 4 Serial number | 10 Hardware version |
| 5 ID number (internal calibration number) | 11 Software version |
| 6 Year of manufacture, country of manufacture | 12 CE mark |

1.6 Safety instructions for electrical installation

The electrical connection may only be made by authorized specialist personnel according to the electrical plans.

The electrical connection information in the manual must be observed; otherwise, the electrical protection type may be adversely affected.

Ground the measurement system according to requirements.

1.7 Returning devices

Use the original packaging or a secure transport container of an appropriate type if you need to return the device for repair or recalibration purposes. Fill out the return form (see the Appendix) and include this with the device.

The EU Directive governing hazardous materials dictates that the owners of any hazardous waste are also responsible for disposing of it.

All devices delivered to the manufacturer must be free from any hazardous materials (acids, alkalis, solvents, etc.).

Pipe components and flowmeter sensors contain hollow spaces. If they have been used in conjunction with hazardous materials, they must therefore be rinsed out in order to neutralize any such substances.

The owner will be charged for any costs incurred as a result of the device not having been adequately cleaned or of any failure to dispose of hazardous materials. The manufacturer reserves the right to return a contaminated device.

Please contact Customer Center Service acc. to page 2 for nearest service location.

1.8 Integrated management system

ABB Automation Products GmbH operates an integrated management system, consisting of:

- Quality management system to ISO 9001:2008
- Environmental management system to ISO 14001:2004
- Occupational health and safety management system to BS OHSAS 18001:2007 and
- Data and information protection management system

Environmental awareness is an important part of our company policy.

Our products and solutions are intended to have a minimal impact on the environment and on people during manufacturing, storage, transport, use, and disposal.

This includes the environmentally-friendly use of natural resources. We conduct an open dialog with the public through our publications.

1.9 Disposal

This product is manufactured from materials that can be reused by specialist recycling companies.

1.9.1 Information on WEEE Directive 2002/96/EC (Waste Electrical and Electronic Equipment)

This product is not subject to WEEE Directive 2002/96/EC or relevant national laws (e.g., ElektroG in Germany).

The product must be disposed of at a specialist recycling facility. Do not use municipal garbage collection points. According to the WEEE Directive 2002/96/EC, only products used in private applications may be disposed of at municipal garbage facilities. Proper disposal prevents negative effects on people and the environment, and supports the reuse of valuable raw materials.

If it is not possible to dispose of old equipment properly, ABB Service can accept and dispose of returns for a fee.

1.9.2 RoHS Directive 2002/95/EC

With the Electrical and Electronic Equipment Act (ElektroG) in Germany, the European Directives 2002/96/EC (WEEE) and 2002/95/EC (RoHS) are translated into national law. ElektroG defines the products that are subject to regulated collection and disposal or reuse in the event of disposal or at the end of their service life. ElektroG also prohibits the marketing of electrical and electronic equipment that contains certain amounts of lead, cadmium, mercury, hexavalent chromium, polybrominated biphenyls (PBB), and polybrominated diphenyl ethers (PBDE) (also known as hazardous substances with restricted uses).

The products provided by ABB Automation Products GmbH do not fall within the current scope of the directive on waste from electrical and electronic equipment according to ElektroG. If the necessary components are available on the market at the right time, in the future these substances will no longer be used in new product development.

Device description

2 Device description

2.1 Front view

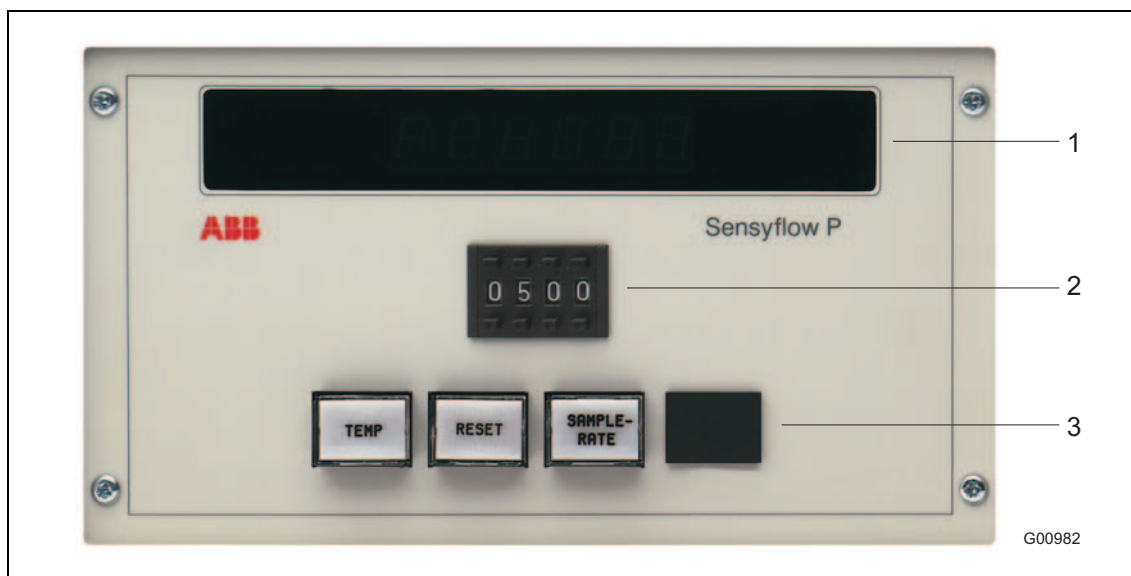

Fig. 3

- 13 Display
- 14 Measuring rate
- 15 Selection buttons
- TEMP
- RESET
- SAMPLE RATE
- UNIT SELECT
- SENSOR SELECT

For selecting the fluid temperature
 For performing a master reset
 Switch for setting the measuring rate
 For switching over to the 2nd display unit
 For switching the flowmeter sensors (meter tubes) over

2.2 Rear view

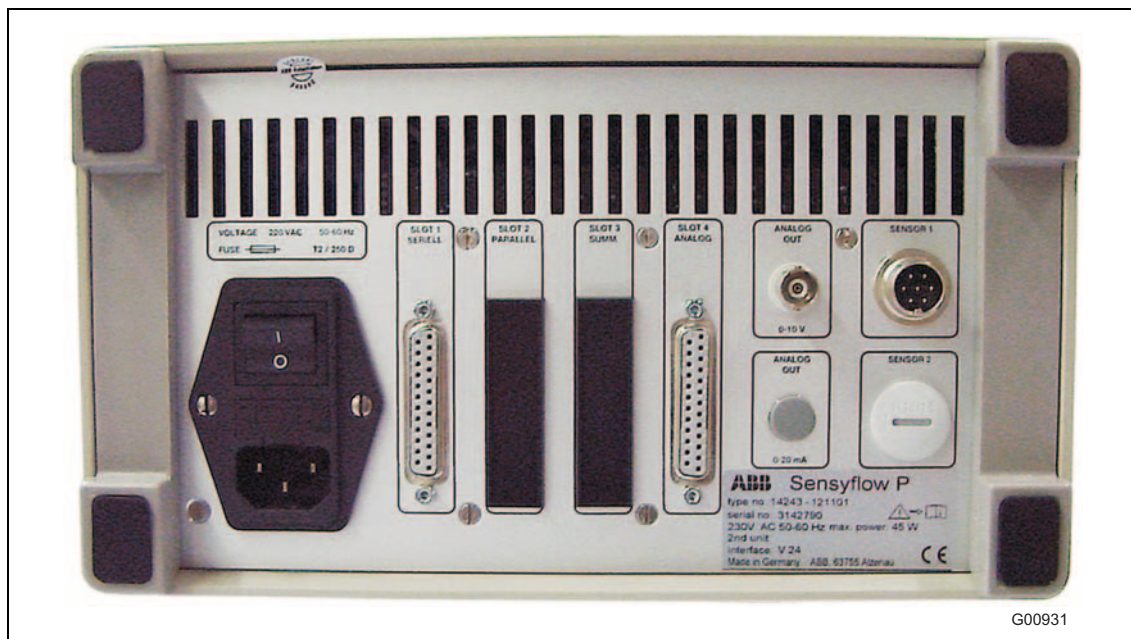

Fig. 4

2.2.1 Supply power

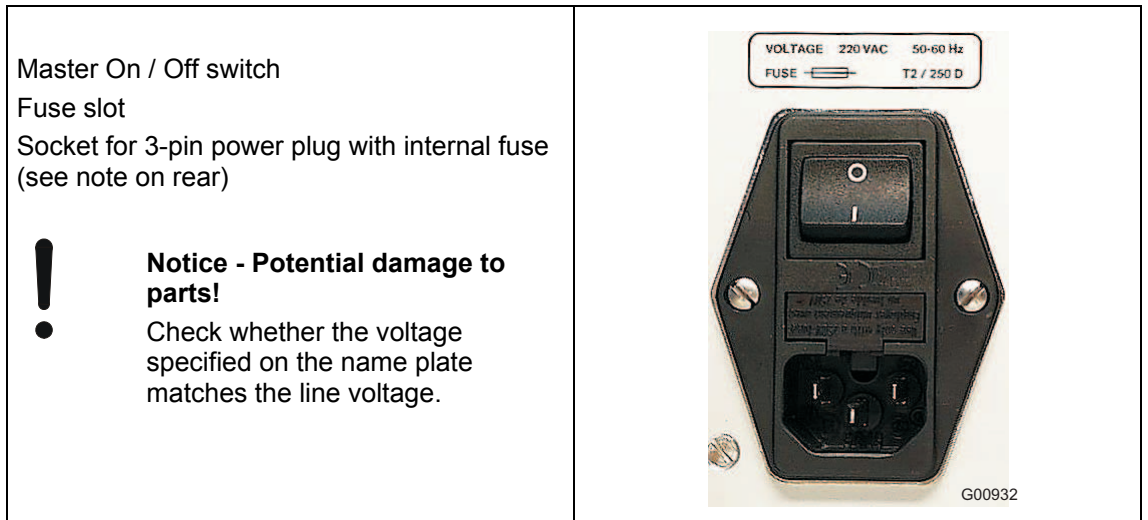

Fig. 5

2.2.2 D-SUB connector

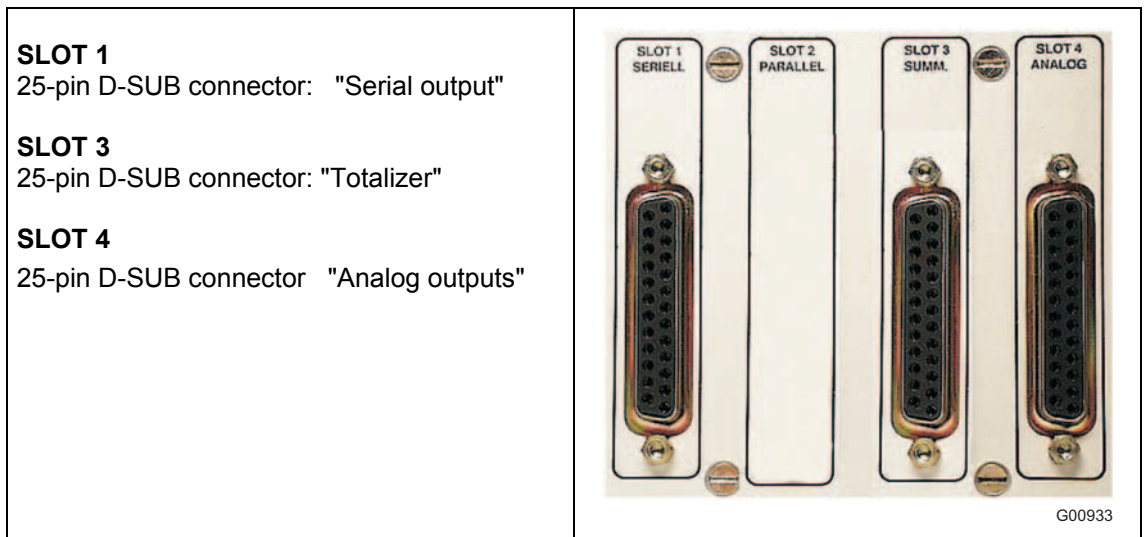

Fig. 6

2.2.3 BNC outputs and sensor connection

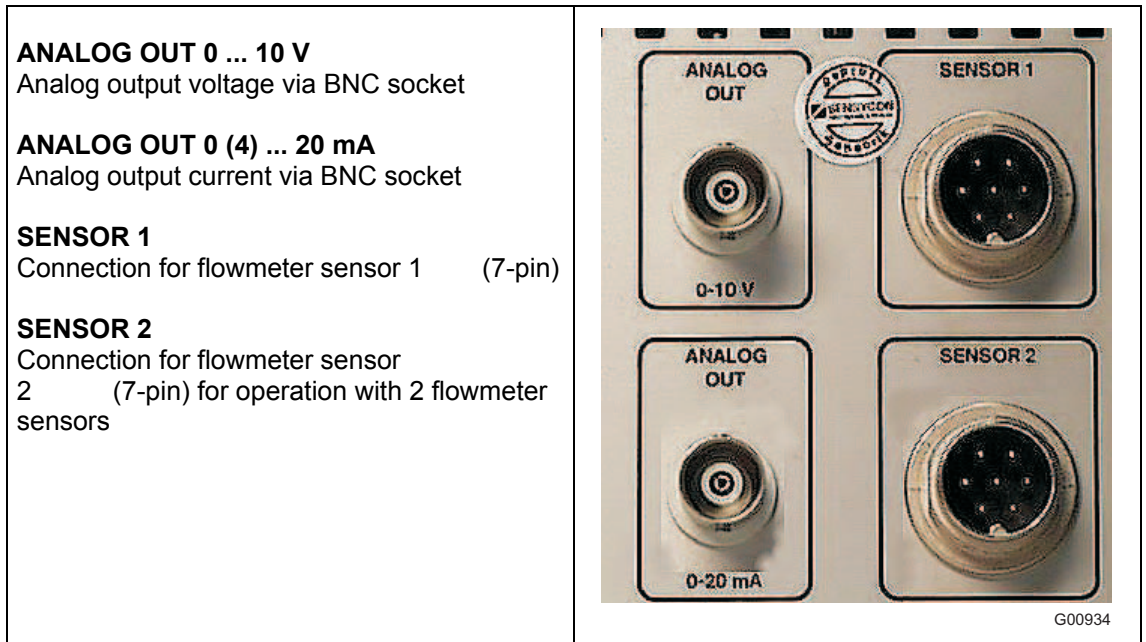

Fig. 7

3 Electrical connections

3.1 BNC outputs and flowmeter sensor connection



<p>BNC outputs Current output: 0 (4) ... 20 mA Voltage output: 0 ... 10 V</p>	 <p>G00923</p>
<p>Flowmeter sensor connection 1 = Temperature signal 2 = Flow signal 3 = Supply voltage (+ 18 V) 4 = Flowmeter sensor coding 2⁰ 5 = Flowmeter sensor coding 2¹ 6 = Flowmeter sensor coding 2² 7 = Flowmeter sensor coding 2³</p>	 <p>G00924</p>

Fig. 8: Terminal connection of BNC socket and flowmeter sensor socket

3.2 SLOT 1: D-SUB connection „Serial Output“

Pin	Assignment	Pin	Assignment
1	-	14	-
2	TxD Transmi data	15	-
3	RxD Receive data	16	-
4	-	17	-
5	-	18	-
6	-	19	-
7	GND	20	-
8	-	21	-
9	-	22	-
10	-	23	-
11	-	24	-
12	-	25	-
13	-		

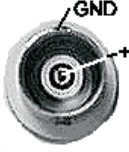

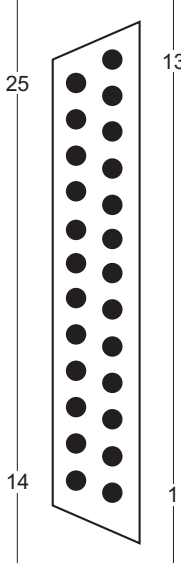
G00925

Fig. 9: Terminal connection of 25-pole D-SUB connection „Serial Output“

3.3 SLOT 3: D-SUB connection „Totalizer“

Pin	Assignment	Pin	Assignment
1	2 ⁰ LSB ¹⁾	14	2 ¹³
2	2 ¹	15	2 ¹⁴ MSB ²⁾
3	2 ²	16	
4	2 ³	17	
5	2 ⁴	18	
6	2 ⁵	19	
7	2 ⁶	20	
8	2 ⁷	21	
9	2 ⁸	22	
10	2 ⁹	23	REMOTE-CTRL ^{START/STOP}
11	2 ¹⁰	24	U _{ext.}
12	2 ¹¹	25	GND _{ext.}
13	2 ¹²		1) LSB = Least Significant Bit 2) MSB = Most Significant Bit

Fig. 10: Terminal connection of 25-pole D-SUB connection „Totalizer“

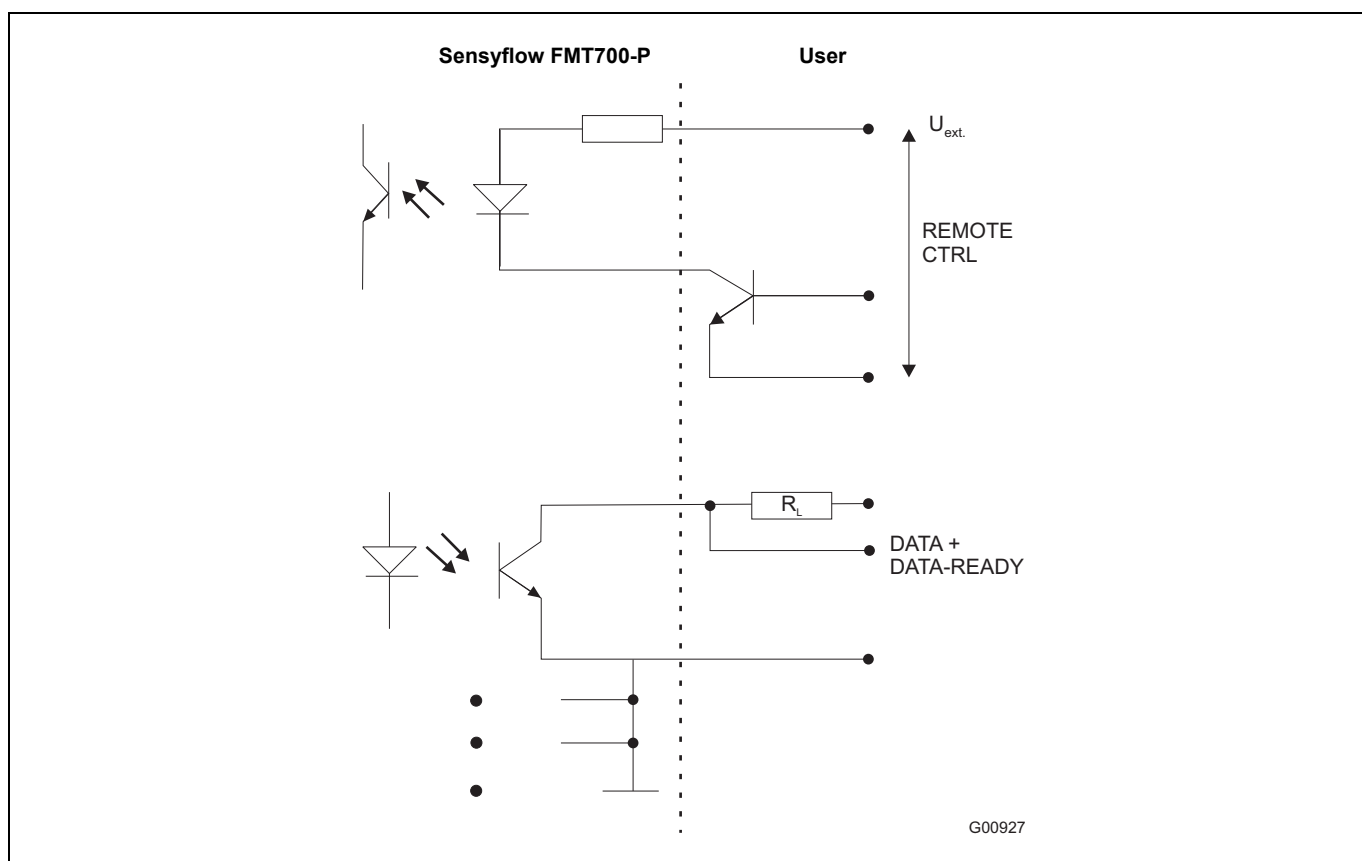

Fig. 11: Terminal connection of inputs / outputs

3.4 SLOT 4: D-SUB connection „Analog Outputs“

Pin	Assignment	Pin	Assignment
1	GND	14	out GND
2	out+	15	Uout GND
3	Uout+	16	GND
4	Flowmeter sensor coding	17	Flowmeter sensor coding
5	Nominal diameter coding	18	Nominal diameter coding
6	Nominal diameter coding	19	Nominal diameter coding
7	Free coding	20	Free coding
8	Free coding	21	Free coding
9	-	22	-
10	-	23	-
11	Temp. 1 +	24	Temp. 1 -
12	Temp. 2 +	25	Temp. 2 -
13	GND _{ext.}		

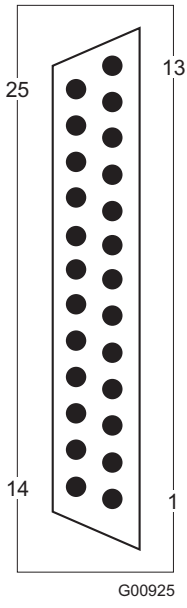

Fig. 12: Terminal connection of 25-pole D-SUB connection „Analog Outputs“

Digital coding of the flowmeter sensor

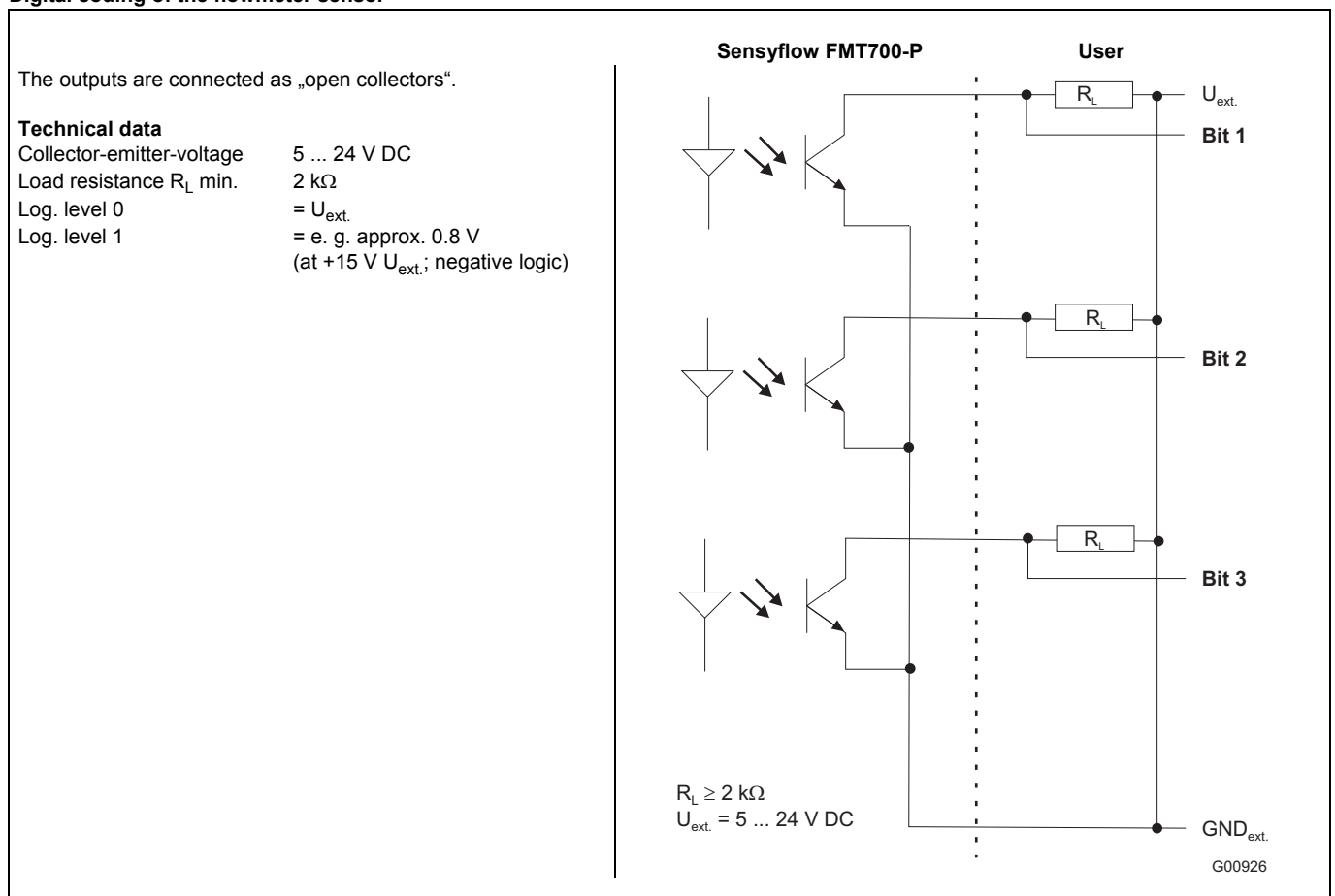

Fig. 13: Terminal connection of open-collector outputs for flowmeter sensor coding

Electrical connections

Nominal diameter coding

	Pin 5	Pin 18	Pin 6	Pin 19	Hex
No measuring tube	0	0	0	0	00
DN 25	1	1	0	0	30
DN 50	1	0	1	0	50
DN 80	1	1	1	0	70
DN 100	1	0	0	1	90
DN 150	1	1	0	1	B0
DN 200	1	0	1	1	D0
Special	1	1	1	1	F0

	Pin 4	Pin 17
Flowmeter sensor 1	1	1
Flowmeter sensor 2	1	0
Medium temperature flowmeter sensor 1	0	1
Medium temperature flowmeter sensor 2	0	0

4 Commissioning

1. Fit the flowmeter sensor in the measuring section. Ensure that the tapered flange connection is secure (tightness) and observe the flow direction (direction indicated by arrow).
2. Connect the flowmeter sensor and supply / evaluation unit using the flowmeter sensor cable (7-pin).
3. Use the power cable supplied to connect the supply / evaluation unit to the permissible supply voltage.
4. Switch on the measuring system using the master On / Off switch.

i

IMPORTANT (NOTE)

Before the device switches to the actual measuring mode, it performs a self-test, during which all the indicators on the "DISPLAY" light up. After a minute, the device is ready for operation. It then takes approximately half an hour to reach maximum measuring accuracy.

The measuring rate is set to $N = 100$. If you require a different measuring rate (option), please refer to section 5.3.1.

Whenever communication between the flowmeter sensor and supply / evaluation unit is interrupted, e.g., after the flowmeter sensor has been changed, you must remember to press the "RESET" button.

If no flowmeter sensor is connected, the "EO2" error message appears to indicate this.

If the "E11" error message appears, it means that you have either pressed the "TEMP" button when there is no temperature sensor with a temperature option or that an error has occurred in the temperature evaluation system.

5 Operation

5.1 Supply / evaluation unit

The supply / evaluation unit involves the use of microprocessor technology. The transmitter signal is linearized and shown directly as a mass or standard volume flow value (e.g., in kg/h or m³N/h)

Thanks to the microprocessor, **one** supply / evaluation unit can cater for all flowmeter sensor nominal diameters with a standard measuring range. It also makes for user-friendly operation.

The device is available as a 19" plug-in module or as a portable desktop unit for a variety of supply voltages (see the section titled "Specifications").



Fig. 14: Supply / evaluation unit as a portable desktop unit

The measuring range of the relevant transmitter is detected automatically when the flowmeter sensor is connected. Measuring range detection has to be performed if there are two flowmeter sensors connected (see section 5.5) and if the measuring signal is to undergo downstream processing in analog format. This measuring range assignment is available at the "analog outputs" socket as a binary code (see section 3.4).

5.2 Display unit (Display)



Fig. 15: Display of the supply / evaluation unit (lamp test during switch-on)

The largest display value supported by the six-digit digital display is 999999.

The units for the measured value indicated appear on the right next to the digital display. The default unit is kg/h. Other units are also supported.

"SENSOR 1" appears when transmitter 1 is selected.

"SENSOR 2" appears when transmitter 2 is selected (see section 5.5).

"TEMP 1" appears when the temperature of the fluid in transmitter 1 is requested.

"TEMP 2" appears when the temperature of the fluid in transmitter 2 is requested (see section 5.4).

"R.C. REMOTE-CTRL" appears when the device is in "Totalizer" mode (see section 6.1.2).

5.3 Options

5.3.1 Adjustable measuring rate

It is often useful to produce an average from the configurable number of individual measurements. You can set the required number of individual measurements using the selector switch on the front of the supply / evaluation unit.

A measuring cycle period (time for an individual measurement) lasts approximately 3 milliseconds. The average value calculated for the number of individual measurements configured is displayed and made available at the interfaces. In standard mode (i.e., when the device is switched on/before the set measuring rate is adopted), the device automatically generates an average value from 100 individual measurements.

If the device generates an average value from fewer than 100 individual measurements, the set measuring rate is used for the analog outputs and the 12-bit parallel interface.

However, the digital display and the serial interface still contain measured values reflecting an average value for 100 individual measurements.

Proceed as follows to set a measuring rate:

1. Set the required measuring rate using the selector switch on the front of the supply / evaluation unit.
2. Press the "SAMPLE RATE" button to accept the set measuring rate. The selected measuring rate appears briefly in the display field as an acknowledgment signal. The measured value that appears after that is the first of the average values to be calculated from the newly configured number N.



IMPORTANT (NOTE)

Whenever the measuring system is switched on or after a reset, the device adopts a measuring rate of N = 100 as soon as the internal test routines have been completed.

Example:

The average mass flowrate needs to be determined using an interval of 3 seconds.

What measuring rate should be set?		
3 s = 3,000 ms	= T	Required interval
N = 1 = 3 ms	= I	Duration of a single measurement
Presetting counter setting	= N	No. of individual measurements
$N = \frac{T}{I} = \frac{3000}{3} = 1000$		

Thus, the measuring rate should be set to N = 1,000 on the switch.

This means that the four-digit switch can be used to produce an average value for the mass flowrate based on up to 9,999 individual measurements.

When a measuring rate of "0000" is selected, the measuring cycle period is just 1 millisecond (see section 5.3.2).

To summarize:

- If a low measuring rate is set, the average is produced from a small number of individual measurements and it is possible to measure and record dynamic processes.
- If a high measuring rate is set, the average is produced from a large number of individual measurements and undesirable fluctuations can be eliminated.

5.3.2 Fast measuring rate

This operating mode is for measuring very fast, dynamic processes. The measuring cycle period is 1 ms, i.e., an updated measured value is made available at the analog outputs and at the 12-bit parallel interface once every millisecond.

Proceed as follows to set this operating mode:

- Set the measuring rate to "0000" using the switch on the front of the supply / evaluation unit.
- Press the "SAMPLE RATE" button to accept this measuring rate. " _ _ _ _ _ " appears on the display along with "FAST MODE".



IMPORTANT (NOTE)

If you want the device to revert to the default setting (N = 100), you need to reset it (press RESET button) or restart it completely.

As soon as the internal test routines have been completed (during which all the indicators light up), the measuring system starts taking measurements using the default measuring rate setting of N = 100 again.

5.3.3 Analog outputs

The following 3 analog outputs are available as options:

- 0 ... 10 V
- 0 ... 20 mA
- 4 ... 20 mA

The previously set measuring rate (see section 5.3.1) is used for the analog interfaces.

Additional signal-processing units can be connected to the analog outputs, e.g.:

- A recorder
- An oscilloscope
- A transient recorder
- A process computer
- A controller

This makes it possible to visualize and record rapidly changing flowrates.

The Sensyflow FMT700-P measuring system has been specially developed for applications that call for a rapid response time where changes in flowrate are concerned. Fig. 16 illustrates the high speed of the measuring signal response when a throttle valve opens compared with the sluggish behavior associated with a orifice plate.

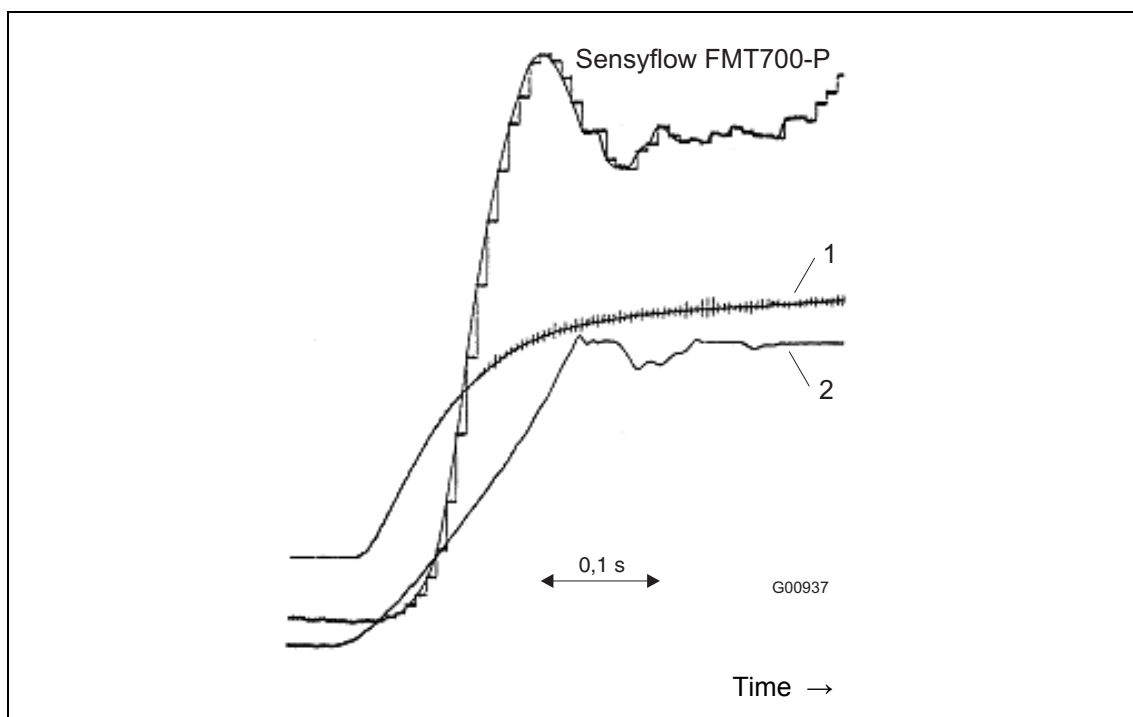

Fig. 16: Dynamic measurement: Comparison of Sensyflow FMT700-P and orifice plate in terms of response time

- 1 Orifice plate
- 2 Position of throttle valve

If a number of follow-on devices are connected to the outputs, these must be connected in parallel in the case of the voltage output and in series in the case of the current output.

Current output

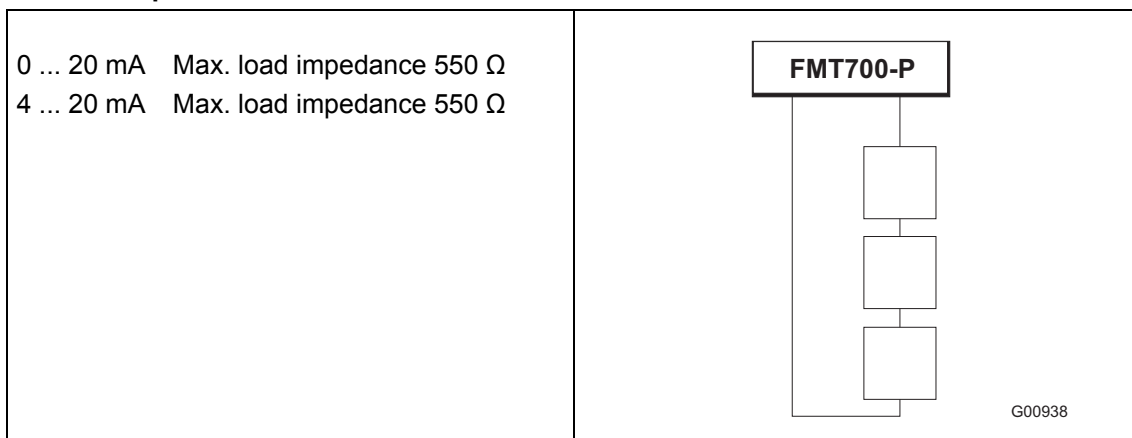

Fig. 17: Additional units at the current output

Voltage output

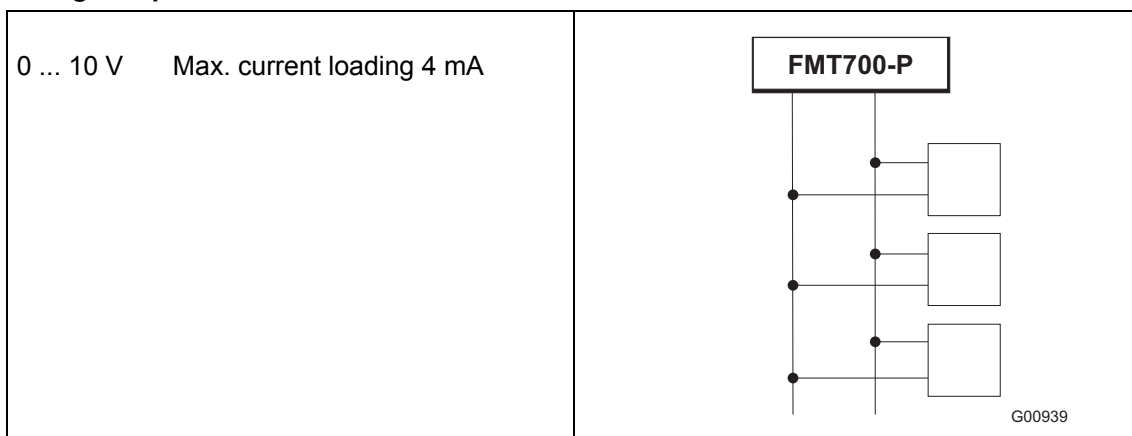

Fig. 18: Additional units at the voltage output

- Connection:
- BNC socket (see section 3.1)
 - D-SUB socket (see section 3.4)

5.4 Temperature measurement

Installing an additional measurement resistor (Pt100) in the flowmeter sensor makes it possible to measure the temperature of the air. With a nominal diameter of DN 25, the Pt100 is installed in the inlet section.

To display the temperature of the fluid, press the "TEMP" button. Press the button again if you want the unit to revert to its initial state (flow measurement).

Measuring principle

Using a transmitter, the Pt100's resistance signal is converted into a temperature-linear 4 ... 20 mA current signal while it is still inside the flowmeter sensor. It is then displayed as a temperature in °C. If you need the temperature signal to undergo downstream electrical processing, a jumper must be removed from inside the device (by the factory). In such cases, the electrical circuit outside the device has to be completed using a display unit or recorder (for example). The maximum permissible load is 120 Ω.

During temperature measurement, the corresponding flowrate signal is **not** made available at the interfaces.

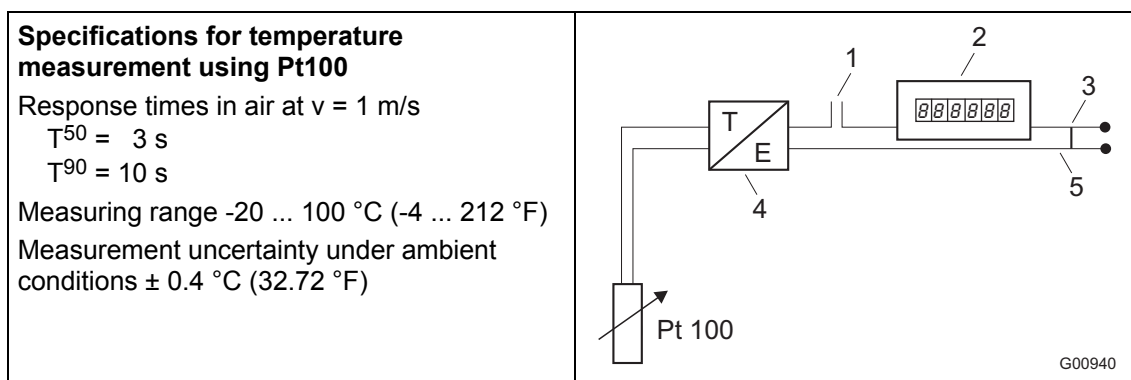

Fig. 19: Gas temperature measurement

- | | |
|---------------------|-----------------------------|
| 1 18 V (internal) | 4 Transmitter |
| 2 Display | 5 Analog output 4 ... 20 mA |
| 3 Jumper (internal) | |

The temperature-linear 4 ... 20 mA signal is made available (once the jumper has been disconnected by the factory) at pins 11 and 24 (or 12 and 25 if operation involves the use of two flowmeter sensors) (see section 3.4).

5.5 Operation with two flowmeter sensors

Two flowmeter sensors with any nominal diameter can be connected to the supply / evaluation unit. Both flowmeter sensors (e.g., DN 25 and DN 150) are constantly available for measurements.



IMPORTANT (NOTE)

Only those measured values for the flowmeter sensor selected via the "SENSOR SELECT" button are shown on the "DISPLAY" and output as an optional digital and / or analog signal. The set measuring rate (see section 5.3.1) applies to both flowmeter sensors.

Selecting the required flowmeter sensor

- Press the "SENSOR SELECT" button until the required flowmeter sensor is selected.
- To determine which flowmeter sensor is active, refer to the display to see if it showing "SENSOR 1" or "SENSOR 2" and / or determine it on the basis of the coding at the 25-pin D-SUB-socket.

6 Communication

6.1 Digital interfaces

The digital interfaces provide the same mass flowrate value as the analog output. They enable you to connect the device directly to digital systems without suffering any loss of accuracy as a result of an additional conversion process. All the signal lines of the digital interface are electrically isolated.

Electrical isolation:

Electrical isolation is achieved by means of an optocoupler consisting of an LED and a phototransistor.

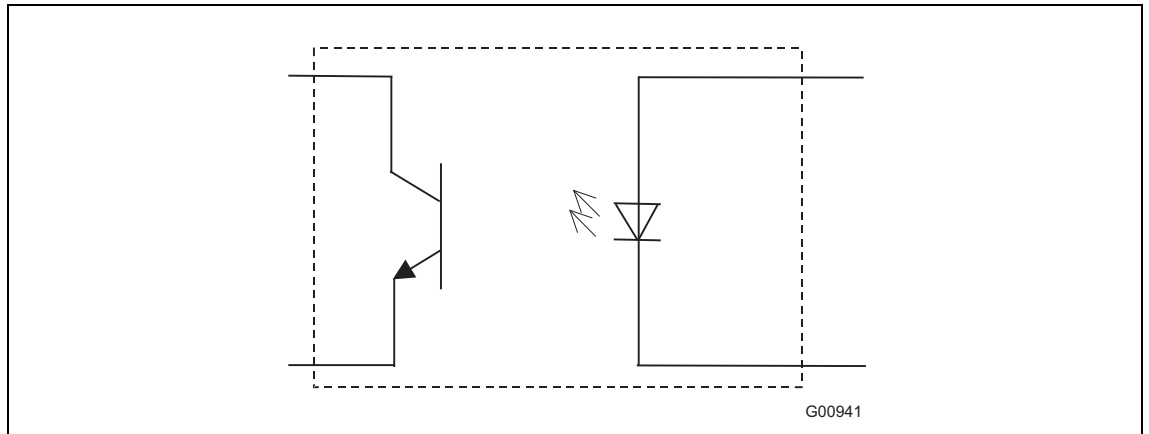

Fig. 20: Optocoupler

6.1.1 Serial interface

The serial interface (V24 / RS 232 C) supports the digital transmission of measured values and can also be used to control all the possible operating functions of the supply /°evaluation unit (bidirectional communication).

For the purpose of serial data transmission, only three lines are required for the systems involved to exchange all the necessary communication signals. Addresses, data and control information are transferred bit by bit. A distinction is made between synchronous and asynchronous serial interfaces.

Synchronous serial data transmission

The transmitter inserts an additional synchronization character into the data stream at defined intervals. At the receiver end, this character is detected using special logic. Any shifts are corrected to ensure that the transmitter and receiver are synchronized.

Asynchronous serial data transmission

The process whereby data is transmitted in small units of equal length without any additional clock information is known as asynchronous data communication without clock signals.

The transmitter and receiver must be clear about the transmission conditions involved, e.g.:

- Transmission speed (baud rate)
- Word length
- Number of start and stop bits (format)
- Bit assignment
- Signal voltage

6.1.1.1 Electrical properties

The voltage level of the transmit and receive data conforms to the EIA (Electronic Industries Alliance) RS 232 C standard and is electrically isolated from the power supply for the supply / evaluation unit.

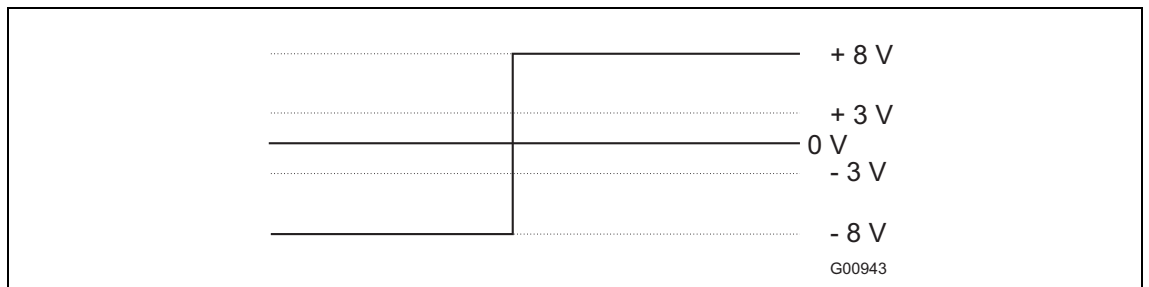

Fig. 21: Voltage level of transmit and receive data

6.1.1.2 Data format

Data transmission is bidirectional and uses ASCII code. The data format used is asynchronous and involves a START BIT and two STOP BITS in each case.

START BIT	0	1	2	3	4	5	6	7	STOP BIT	STOP BIT
-----------	---	---	---	---	---	---	---	---	----------	----------

The supply / evaluation unit is ready to receive data as soon as it is switched on. The baud rate set at the factory is 9,600 bit/s.

The software description provided below relates to versions 7.10 and 7.11 (without "Totalizer").

Control characters used

Short form	Description	Hex code	Decimal code
EOT	End of Transmission	04	04
LF	Line Feed	0A	10
CR	Carriage Return	0D	13
CLS	Clear Screen	1A	26
IV	Inverse Video	1B, 47, 34	27, 71, 52
DV	Default Video	1B, 47, 30	27, 71, 48



IMPORTANT (NOTE)

Although all the control characters listed are transmitted, they are not displayed on a potential monitor.

6.1.1.3 Command list

Enter the command **XB**^{CR} to access the command list.

When a monitor is connected, the following text appears:

CLS

Command list

Command	Description
<XR>	Reset supply / evaluation unit
<XTT>	Transmits general information
<XB>	Transmits interface command list
<XF>	Transmits error table
<XS>	Constantly transmits flowrate in selected unit
<XH>	Stops <XS> output and enables interface
<XE>	Only one measured value is transmitted
<XA>	Transmits totalized mass / standard volume in g/l once the stop bit has been set (externally triggered)
<XZ>	Measuring rate change for display and analog out Example: <XZ0100 ^{CR} >; <XZ0005 ^{CR} > !!! 4-character cycle number must be used
<XSR>	Requests the set SAMPLE RATE
<XU0>	Selects first unit: kg/h
<XU1>	Selects second unit: e.g., m ³ N/h
<XSW1>	Switches sensor 1 to supply / evaluation unit
<XSW2>	Switches sensor 2 to supply / evaluation unit
<X\$>	Transmits length of individual strings
<XTR>	Transmits most recently measured temperature value. If no transmitter is connected, E 11 appears on the display; in the event of a Pt100 sensor break: E 12
<XT1>	Switches temperature measurement sensor 1, value transmitted via <XTR>
<XT2>	Switches temperature measurement sensor 2, value transmitted via <XTR>

Sensor / Transmitter = flowmeter sensor

6.1.1.4 List of telegrams requested via commands

Command	Response telegram
XE	MF: 044.30 kg/h sensor 1 DN 25; transmits individual measured value
XS	MF: 044.30 kg/h sensor 1 DN 25; transmits constantly
XH	Stops constant transmission mode and enables transmitter (no feedback)
XZ0400	CLS The SAMPLE-RATE is now 400
XZ0000	CLS The supply / evaluation unit is in FAST MODE <ul style="list-style-type: none"> - The display is no longer used - Each measured value is output at the analog output - Certain switchover functions are excluded and can only be changed on the the front panel
XTT	General information about the interface is transmitted (see section 6.1.1.5)
XTR	T = 035.4 °C
XA	CLS SU: 12309 grams sensor 1 DN 50
XSR	CLS SR1: 0100 measuring cycles / SR2: 0001 measuring cycle
XR	Forces a software reset (no feedback)
XSW1	CLS Probe 1 is switched
XSW2	CLS Probe 2 is switched
XT1	CLS Temperature of fluid at probe 1 is measured
XT2	CLS Temperature of fluid at probe 2 is measured
XB	Complete command list is transmitted (see section 6.1.1.3)
XF	Complete error table is transmitted (see section 6.1.1.6)
XU0	CLS The unit is now kg/h
XU1	CLS The unit is now m ³ N/h at 20 °C
X\$	String table is transmitted (see section 6.1.1.7)

Sensor / Probe = flowmeter sensor

6.1.1.5 General information

Enter the command **XTT** ^{CR} to access general information about the interface. When a monitor is connected, the following text appears:

CLS, IV General information
 Vers. X.XX
 Progr. Sensyflow FMT700-P

Digital interfaces	15-bit output + data ready 12-bit digital out / optically decoupled
Serial interface	RS 232 / V 24
Serial interface command list	<XB>
Analog interface	0 ... 10 V or 0 ... 20 mA / 4 ... 20 mA
Digital coding of flowmeter sensor size	E.g., DN 25 Sensor 1 1100 1100
Measuring rate for display and analog output changed via BCD switch	
Measuring rate for display	0100 ... 9999 measuring cycles
Measuring rate for analog out	0001 ... 9999 measuring cycles
Fast mode	Display not used; each measured value is sent to the analog output
Temperature option	Measuring range -20 ... 100 °C
2-probe operation	Switchover between 2 sensors

Sensor / Probe = flowmeter sensor

6.1.1.6 Error table

Enter the command **XF** ^{CR} to access the error table. When a monitor is connected, the following text appears:

CLS
 "Sensyflow FMT700-P" error table

Error	Description
999999	Measured value ≥ measuring range (normal operation)
E02	No probe connected
E03	Sum register overflow
E04	A measured value > probe's URL
E11	No transmitter connected
E12	Pt100 sensor break
E13	...
E14	...
E15	...
E16	...
E17	...
E18	...
E19	...
E20	...

Sensor / Probe / Transmitter = flowmeter sensor

URL = Upper range limit

6.1.1.7 Length of transmitted strings

Enter the command **X\$** to access the string table. When a monitor is connected, the following text appears:

CLS

Length of transmitted strings:

String	Length in hexadecimal format	Length in decimal format	
<XTT>	03AD	941	
<XB>	0421	1057	
<XF>	02C6	710	
<XS>	0020	32	
<XH>			Resets interface
<XE>	0020	32	
<XA>	0020	32	
<XZ>	0025	37	
<XSR>	002A	42	
<XTR>	0012	18	
<XU0>	0022	34	
<XU1>	002F	47	
<XSW1>	001B	27	
<XSW2>	001B	27	
<X\$>	03AD	941	
<XT1>	0034	52	
<XT2>	0034	52	

Comment

1. <XS> transmits constantly
2. Each command must end with CR



IMPORTANT (NOTE)

- 4 characters must always be entered when setting the measuring rate (see section 5.3.1), e.g., for a SAMPLE RATE of 50, the command XZ __ 50 CR must be entered.
- During constant transmission mode, no other operating mode can be set via the serial interface. The RS 232 C serial interface is blocked and can only be enabled using XH CR.
- When the meter is being operated, there is no conflict between the serial interface and the keypad on the front panel. No priority circuit is required.
- During FAST MODE, all the values and tables stored in the memory (texts, temperatures, lists, etc.) can be accessed via the serial interface.
- While this is happening (processing time), FAST MODE is interrupted (analog value is retained). Once processing is complete, FAST MODE is resumed.
- You can exit this operating mode again using the commands CR or XZ CR.

6.1.2 Totalizer (integrator function)

This operating mode is used to determine the air mass that flows through the flowmeter sensor during a defined measurement period that is externally triggered. The result is displayed digitally and can be read out via the serial interface or via a 15-bit parallel interface (binary-coded, electrically isolated) (see section 3.3).

The unit used for the totalized value is either grams or normal liters.

The measurement period (T_m) is defined by the external START / STOP signal at the REMOTE CTRL input.

The START signal (falling edge at REMOTE CTRL input) triggers switchover to the special operating mode and simultaneously initiates the measuring process.

The STOP signal (marking the end of the measuring process) is triggered by a rising edge at the REMOTE CTRL input (see section 3.3).

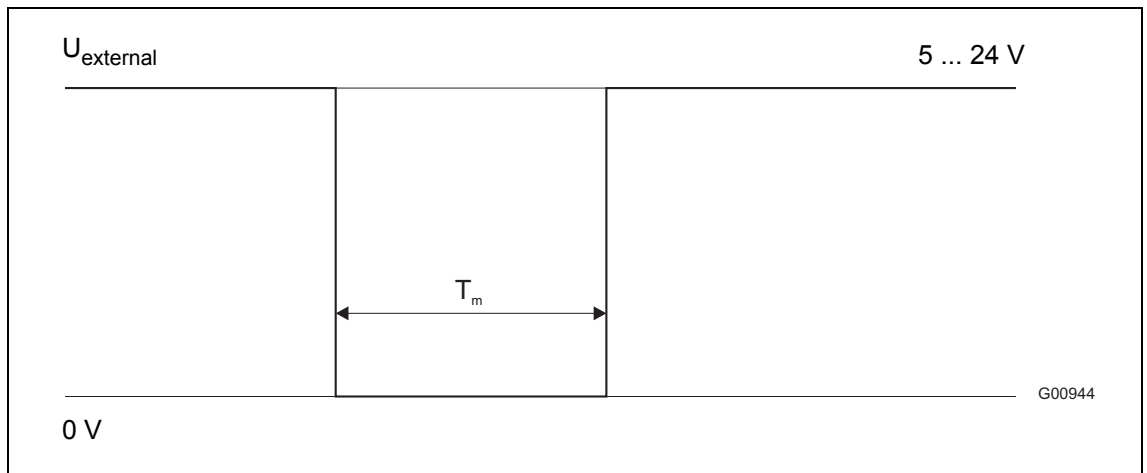

Fig. 22: Voltage states at REMOTE CTRL input

While this special mode is active, the REMOTE CTRL indicator (RC) to the left of the 6-digit LED display lights up.

The 6-digit LED display is switched off and the measuring rate setting is deactivated. The current flowrate remains constantly available at the analog output during this period (measuring rate $N = 1 = 1 \text{ ms.}$; see section 5.3.1).



IMPORTANT (NOTE)

If one or more individual measured values exceeds the calibrated measuring range while the special mode is active, all DATA BITS are set once the STOP signal is detected, as is the DATA READY BIT.

When the device switches back to normal operation, 999999 initially appears on the display before normal operation is resumed.

6.1.2.1 How the totalized value is represented

The value can be represented in 3 ways:

<p>1. Shown on display</p>	<p>"1." is generally combined with "2." or "3."</p> <p>The display period is determined by 2 factors:</p> <ul style="list-style-type: none"> - A fixed "readout time", approx. 5 seconds - The set measuring rate (see section 6.2.1) <p>The result is displayed in grams (g) or normal liters (l_N).</p>
<p>2. 15-bit parallel interface</p>	<p>Following the STOP signal, the mass flowrate value ("m") is made available at the digital output for approx. 15 seconds in the form of a digital 15-bit binary signal along with the DATA READY BIT.</p> <p>For details of pin assignment, see section 3.3. The measured value ("m") is output in grams (g) or normal liters (l_N).</p> <p>After approx. 5 seconds, the device automatically switches over to the normal operating mode.</p>
<p>3. Serial interface</p>	<p>As with the 15-bit interface, the START / STOP signal is implemented using pins 23 and 24 of the 25-pin D-SUB socket (see section 3.3).</p> <p>Once the measuring process is complete, the totalized value is stored. Use the command XA^{CR} to retrieve this value.</p>

6.1.2.2 Specifications for the special "Totalizer" mode

All signal lines of the digital inputs and outputs are optically decoupled.



IMPORTANT (NOTE)

The outputs are connected as OPEN COLLECTORS (see section 3.3).

Permissible measurement period T_M	$10 \text{ s} \leq T_M \leq 115 \text{ s}$
Error due to measurement interval	0.05 % with $T_M = 100 \text{ s}$ 0.15% with $T_M = 10 \text{ s}$
Measurement uncertainty when determining air mass	$\pm 2 \%$
Auxiliary voltage required (UEXTERNAL)	5 ... 24 V DC (I = 20 mA at 20 V)
Totalized measured value M	$M \leq 32,767 \text{ g} ((2^{15} \dots 1) \text{ g})$
The max. permissible measurement period depends on the mass flowrate.	

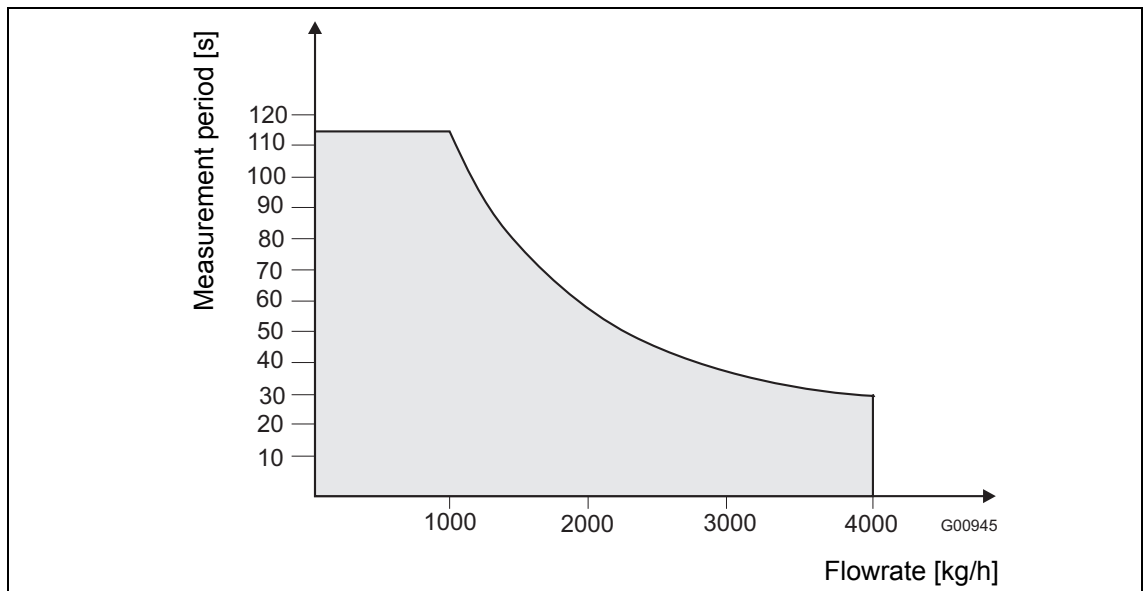

Fig. 23: Measuring range of totalizer

7 Measuring setup and installation

The flowmeter sensor has been designed for maximum measuring accuracy while at the same time being easy to use. Nevertheless, certain boundary conditions must be observed to ensure the best possible absolute accuracy and reproducibility.

Maximum measuring accuracy is achieved by calibrating the measuring section together with the flowmeter sensor (achievable accuracy: $m = \pm 1\%$ from measured value).

By identifying the correct honeycomb/sieve combination on the basis of calculations as well as a process of trial and error, you can steady the flow with a view to minimizing the effect of inlet conditions on the probe characteristic.

The flowmeter sensors are calibrated in the horizontal mounting position. The signal is only slightly dependent on the mounting position.

Optimum measuring section setup:

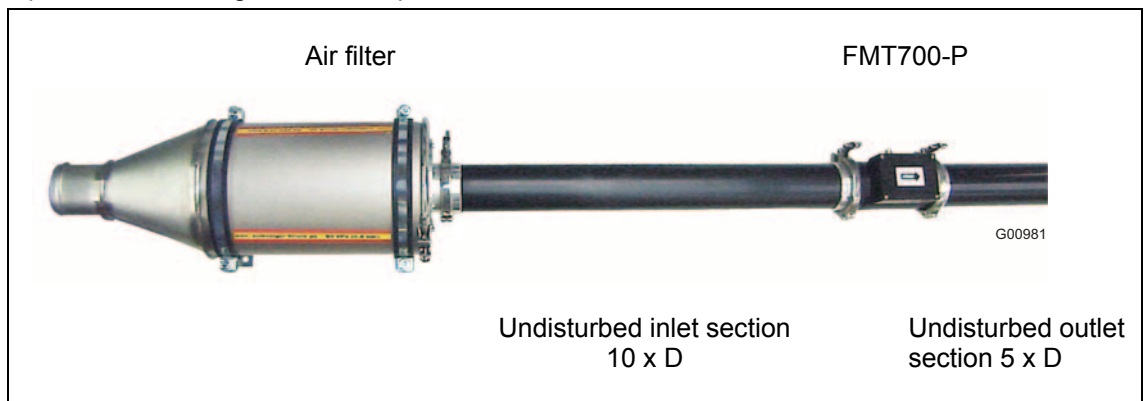

Fig. 24: Preferred setup for a measuring section involving the Sensyflow FMT700-P

i

IMPORTANT (NOTE)

- The flow direction of the measuring fluid must match the arrow on the probe.
- Particles and fibers can impair measuring accuracy. We therefore recommend that you use an air filter from our range of accessories for filtering purposes (see section 9.4). The use of suitable air filters is essential to ensuring desirable inflow characteristics and high levels of operational reliability during continuous operation, even under difficult operating conditions.
- Backflow and pulsation problems can be reduced or fully compensated by installing a suitable surge drum upstream.
- If the optimum measuring setup is not possible due to space restrictions (e.g., trial run), the flowmeter sensor can also be installed using straightforward equipment (rubber sleeve). Even then, the device will still be able to deliver good measurement results.
- The flowmeter sensor and all original accessories have been designed in such a way that they can be very easily adapted using tapered flange couplings.
- Do not attach the flowmeter sensor directly to systems that are subject to high levels of vibration. We recommend that you adapt them by using a rubber sleeve to isolate the vibrations. The honeycomb must be protected from mechanical damage.
- To ensure fault-free signal processing, only the original probe cable should be used.
- The measuring system must undergo regular control calibrations on the manufacturer's test bench. The intervals involved will depend on the operating time and the nature of the load; however, we generally recommend calibration intervals of 12 ... 24 months.

Adaptation options

- DN 25, DN 50, DN 80, DN 100:
Tapered flanges are centrally compressed using a tension clip (vacuum clamping technology).
- DN 150, DN 200:
Tapered flanges are centrally compressed using a tension chain.

8 Specifications

Measuring principle

Thermal: hot-film anemometer

Input

Measuring medium

Flow rate of air

Measuring ranges (standard)

Nominal diameter	kg/h
DN 25	0 (1) ... 60
DN 50	0 (10) ... 400
DN 80	0 (20) ... 720
DN 100	0 (40) ... 1200
DN 150	0 (80) ... 2400
DN 200	0 (200) ... 4000

Output

Output signals

Analog

0... 10 V	(< 4 mA)
0... 20 mA	(load < 500 Ω)
4... 20 mA	(load < 500 Ω)

Digital output

serial V24 / RS 232 C, electrically isolated

Characteristics

Accuracy

Measured error (including hysteresis and non-linearity)

< ± 1 % of measured value

Repeatability

< ± 0.25 % of measured value

Influences

Temperature effect

< 0.03 % / K of measured value

Pressure effect

≤ 0.2 % / 100 kPa (/bar) of measured value

Response time

T63 ≈ 12 ms

Pressure drop flowmeter sensor

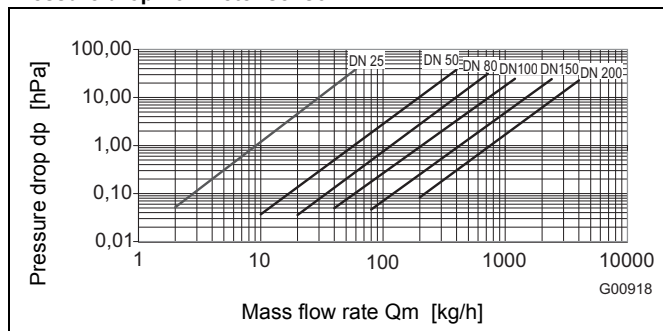

Fig. 25: Pressure drop under atmospheric conditions

Pressure drop of air filter

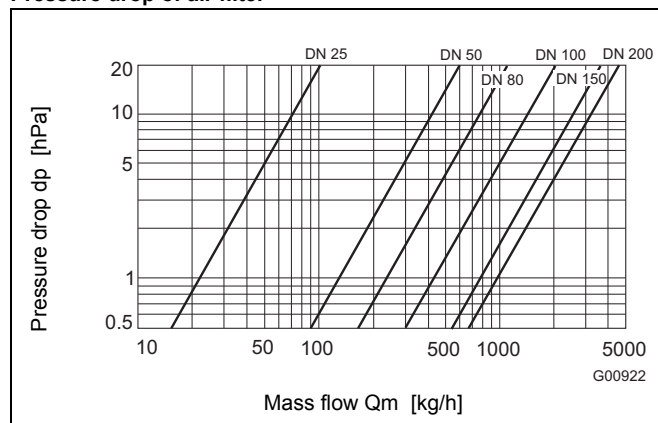

Fig. 26: Pressure drop of air filter

Operating conditions

Required steadying length

- Flow conditioner
- Inlet section 10 x D
- Outlet section 5 x D

Environmental conditions

Ambient temperature for sensor

-25 ... 80 °C (-13 ... 176 °F)

Ambient temperature for evaluation unit

-25 ... 50 °C (-13 ... 122 °F)

Storage temperature

-25 ... 85 °C (-13 ... 185 °F)

Type of protection

IP 54 (sensor)

Measuring medium conditions

Measured medium temperature

-25 ... 80 °C (-13 ... 176 °F)

Operating pressure

Standard: 0.6 ... 2.5 x 10² kPa (2.5 bar abs.)

Option: 0.6 ... 8 x 10² kPa (8 bar abs.)

only DN 25

Dimensions

9 Dimensions

9.1 Flowmeter sensor Sensyflow FMT700-P, DN 25

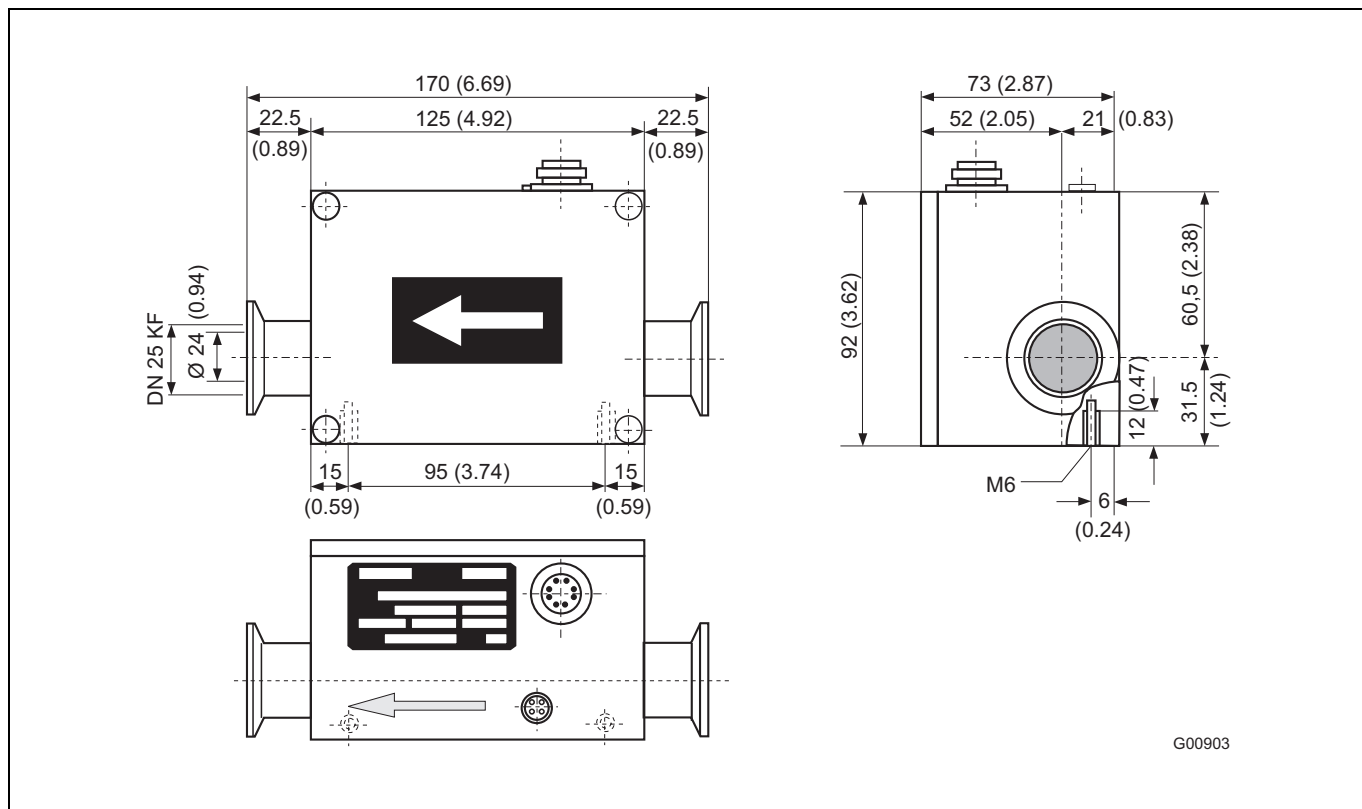

Fig. 27: Dimensions in mm (inch)

9.2 Flowmeter sensor Sensyflow FMT700-P, DN 50 ... DN 200

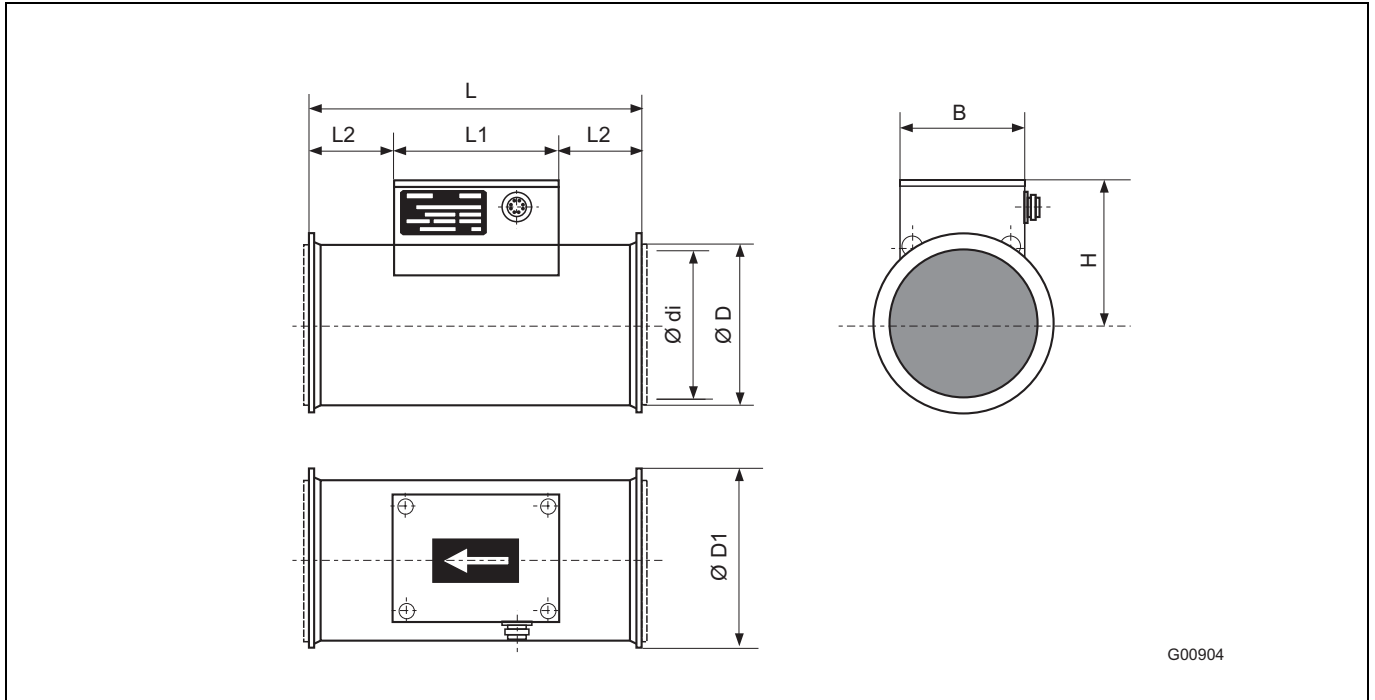

Fig. 28: Dimensions in mm (inch)

DN	Ø D	Ø D1	Ø di	L	L1	L2	B	H
50	64 (2.52)	80.0 (3.15)	58 (2.28)	184 (7.24)	125 (4.92)	29.5 (1.16)	92 (3.62)	88.0 (3.46)
80	89 (3.50)	108.5 (4.27)	80 (3.15)	189 (7.44)		32.0 (1.26)		98.5 (3.88)
100	118 (4.65)	132.5 (5.22)	110 (4.33)	254 (10.00)		64.5 (2.54)		114.0 (4.49)
150	158 (6.22)	180.0 (7.09)	153 (6.02)	280 (11.02)		77.5 (3.05)		136.0 (5.35)
200	205.6 (8.09)	240.0 (9.45)	200 (8)	330 (12.99)		102.5 (4.04)		161.5 (6.36)

Dimensions in mm (inch)

Dimensions

9.3 Supply / evaluation unit

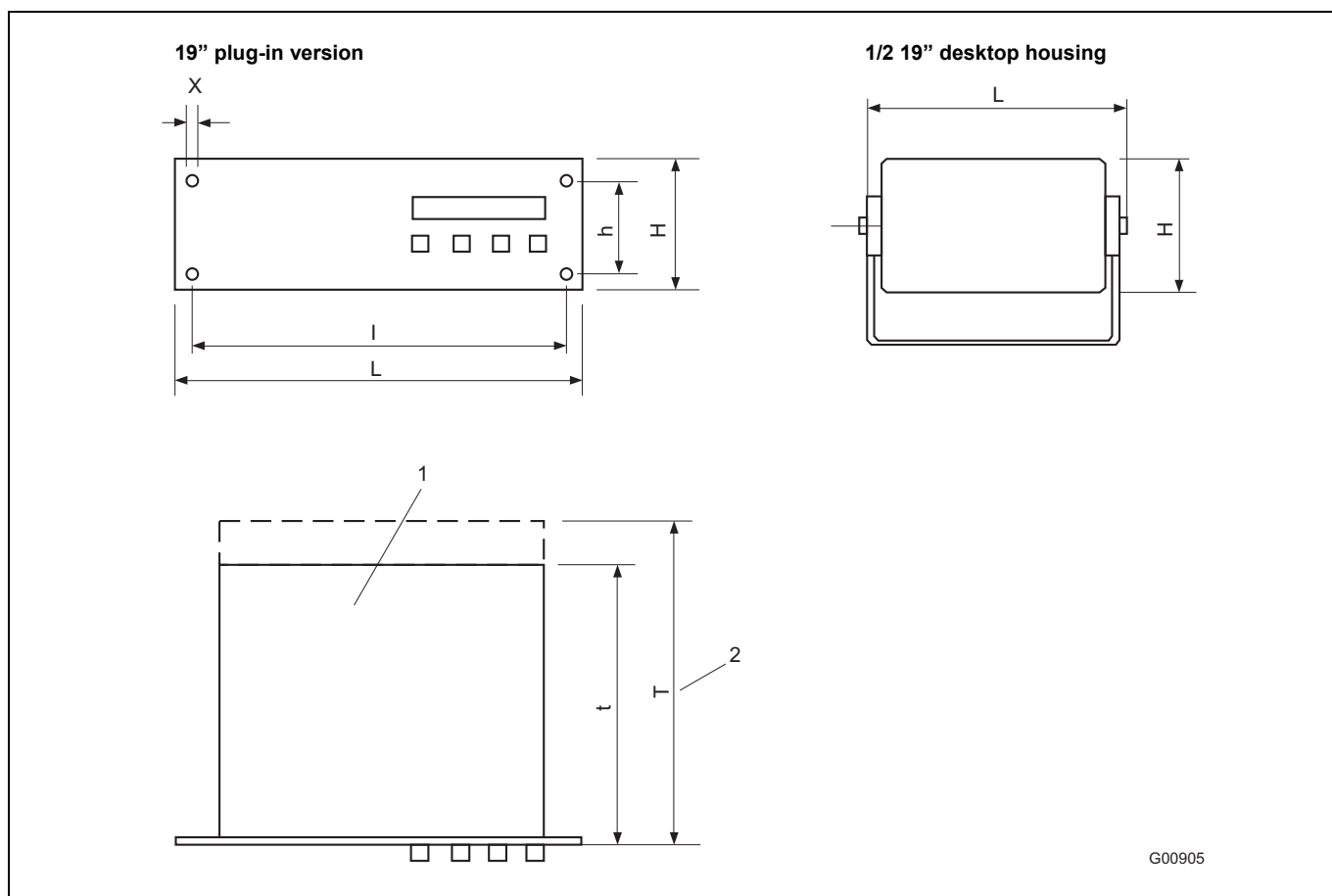

Fig. 29

- 1 Required cutout for 19" unit: 450 x 131 mm (17.72 x 5.16 inch)
- 2 For wiring

Unit	Dimensions	L	l	H	h	T	t	X
1/2 19" desktop housing		310 (12.2)	-	140 (5.5)	-	-	-	-
19" plug-in version		483 (19.0)	462 (18.2)	132 (5.2)	58 (2.3)	425 (16.7)	325 (12.8)	M6

Dimensions in mm (inch)

9.4 Accessories

In order to simplify the installation of our measuring system for the user, we recommend to apply approved components from our extensive accessories program.

Tubes of different lengths as inlet section or outlet section are available which can be combined with an air filter.

We recommend an undisturbed inlet section of 10 x D, a outlet section of 5 x D and the application of an air filter (this combination represents the calibration set of the manufacturer).

D = tube diameter.

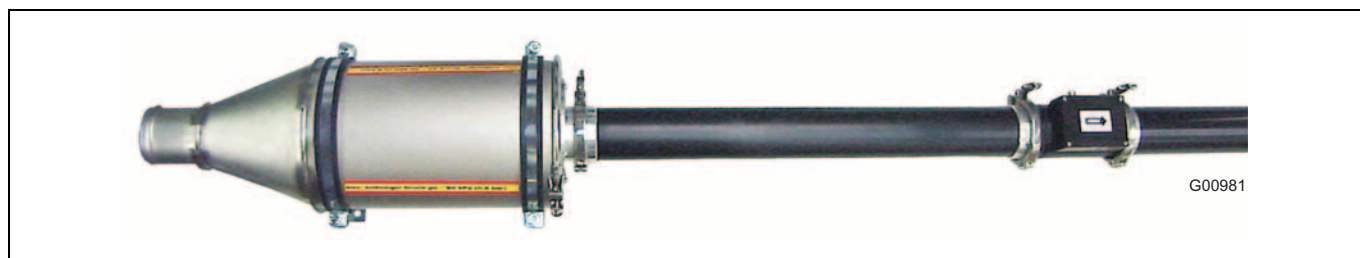
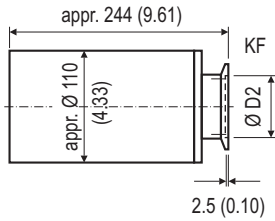

Fig. 30: Standard measuring section: measuring section 3

Modules DN 25

KF = ISO KF flange (ISO small flange)

①
Air filter (open)
with flange



②
10 x D inlet section
with flanges
(on both sides)

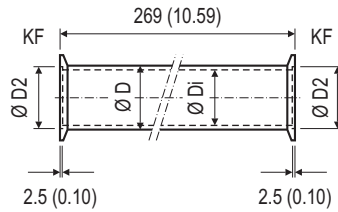

③
5 x D outlet section
with flanges
(on both sides)

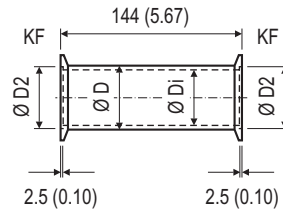

⑥
Hose adapter
with flange
(on one side)

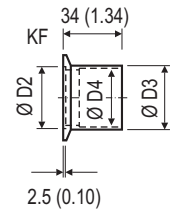

④
10 x D inlet section
with flange
(on one side)

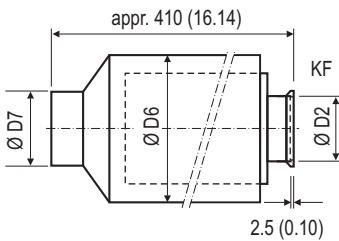

⑤
5 x D outlet section
with flange
(on one side)

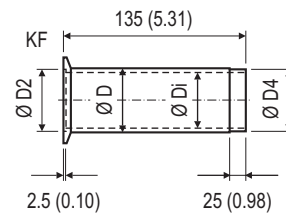
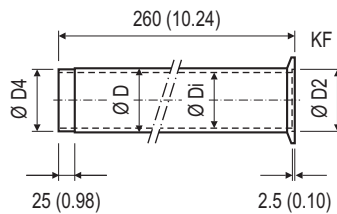

Standard measuring section

Measuring section 3
(Flow conditioner)

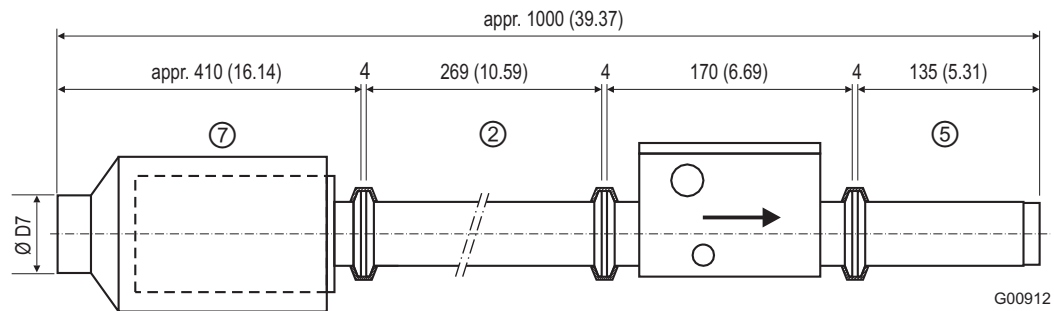

G00912

Fig. 31: Dimensions in mm (inch)

DN	Ø D	Ø D2	Ø D3	Ø D4	Ø D6	Ø D7	Ø Di
25	32 (1.26)	26.1 (1.03)	30 (1.18)	27 (1.06)	appr. 150 (5.91)	60 (2.36)	24 (0.94)

Dimensions in mm (inch)

Modules DN 25

KF = ISO KF flange (ISO small flange)

⑫
O-ring



⑬
Clamping ring
FL-special

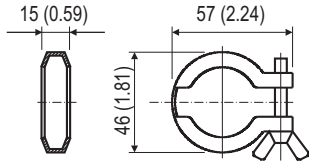

⑪
Inner
center ring

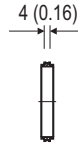

⑭
Clamping ring
FL-Optimal AS

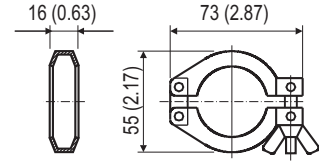

⑥ ⑪ / ⑫ ⑥

Sectional detail pipe connection
(without clamping ring)

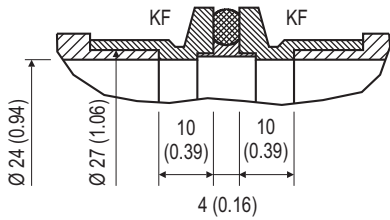

Individual planning

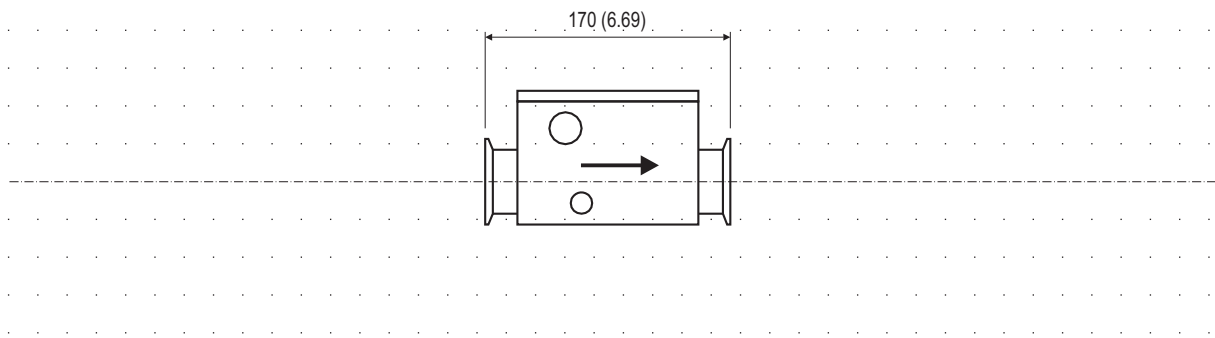

G00919

Abb. 32: Dimensions in mm (inch)

Modules DN 50 ... DN 100

KOF = Tapered flange (with recessed face and groove for O-ring)
 ZWF = Intermediate flange (with raised face)

①

Air filter (open) with flange

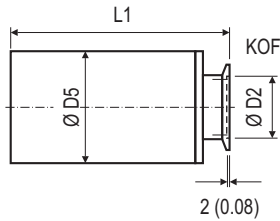

②

10 x D inlet section with flanges (on both sides)

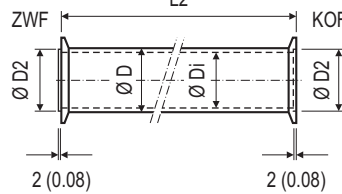

③

5 x D outlet section with flanges (on both sides)

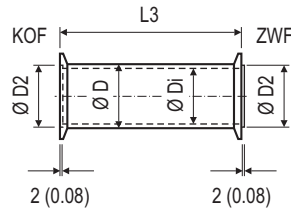

④

Hose adapter with flange (on one side)

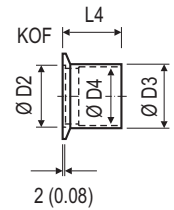

⑦

Flow conditioner with flange

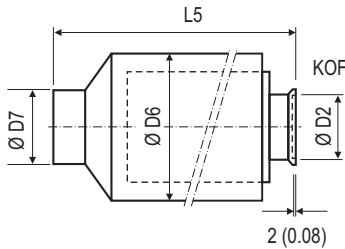

④

10 x D inlet section with flange (on one side)

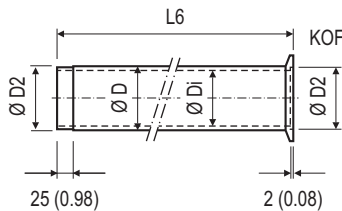

⑤

5 x D outlet section with flange (on one side)

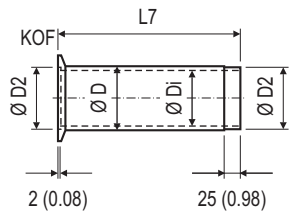

Standard measuring section

Measuring section 3 (Flow conditioner)

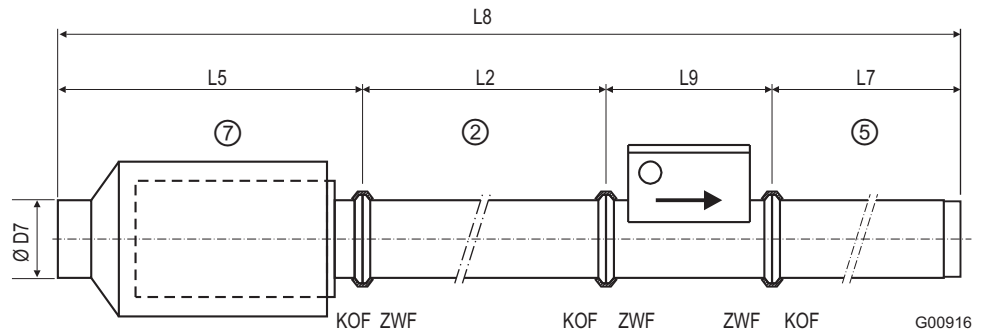

Fig. 33: Dimensions in mm (inch)

DN	L1	L2	L3	L4	L5	L6	L7	L8	L9
50	appr. 356 (14.02)	506 (19.92)	256 (10.08)	50 (1.97)	appr. 660 (25.98)	504 (19.84)	254 (10.00)	appr. 1600 (62.99)	184 (7.24)
80	appr. 401 (15.79)	806 (31.73)	406 (15.98)	80 (3.15)	appr. 740 (29.13)	804 (31.65)	404 (15.91)	appr. 2140 (84.25)	189 (7.44)
100	appr. 526 (20.71)	1006 (39.61)	506 (19.92)	100 (3.94)	appr. 840 (33.07)	1004 (39.53)	504 (19.84)	appr. 2610 (102.76)	254 (10.00)

DN	Ø D	Ø D2	Ø D3	Ø D4	Ø D5	Ø D6	Ø D7	Ø Di
50	66 (2.60)	64 (2.52)	70 (2.76)	60 (2.36)	appr. 150 (5.91)	appr. 200 (7.87)	78 (3.07)	58 (2.28)
80	91 (3.58)	89 (3.50)	95 (3.74)	85 (3.35)	appr. 200 (7.87)	appr. 250 (9.84)	98 (3.86)	80 (3.15)
100	119 (4.69)	118 (4.65)	122 (4.80)	114 (4.49)	appr. 240 (9.45)	appr. 300 (11.81)	148 (5.83)	110 (4.33)

Dimensions in mm (inch)

Dimensions

Modules DN 50 ... DN 100

KOF = Tapered flange (with recessed face and groove for O-ring)

ZWF = Intermediate flange (with raised face)

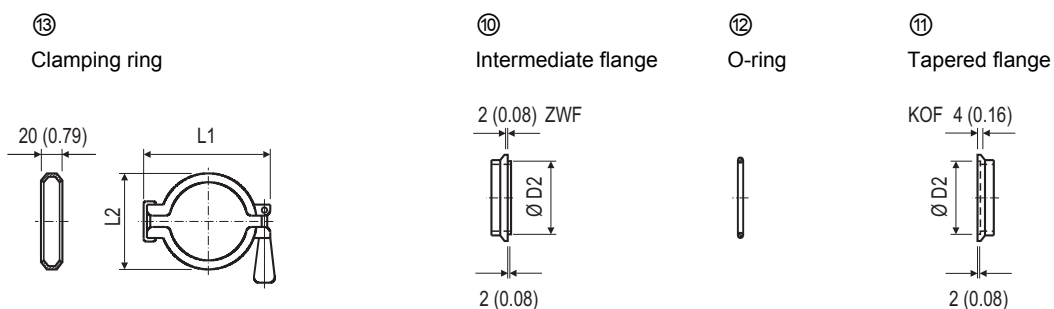

⑩ ⑫ ⑪
Sectional detail pipe connection
(without clamping ring)

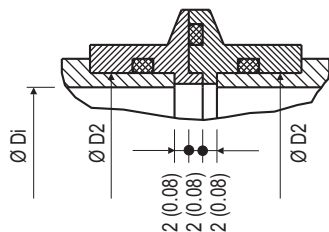

Individual planning

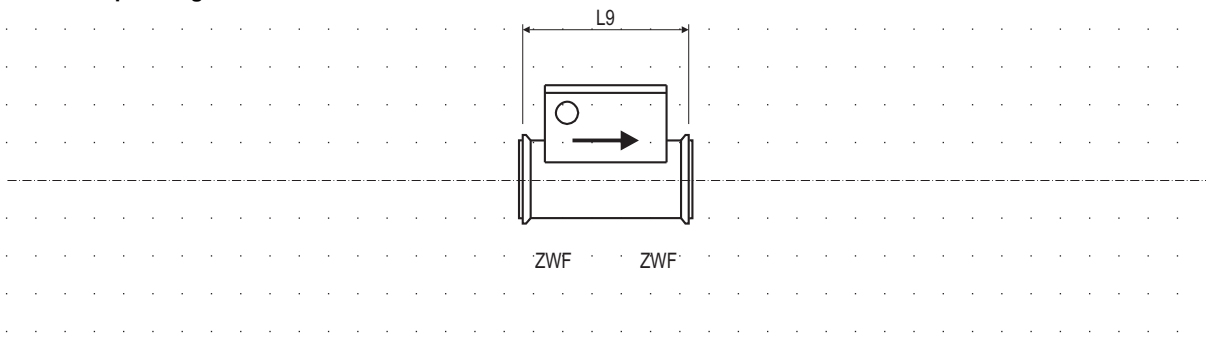

G00920

Fig. 34: Dimensions in mm (inch)

DN	L1	L2	L9	Ø D2	Ø Di
50	102 (4.02)	72 (2.83)	184 (7.24)	64 (2.52)	58 (2.28)
80	145 (5.71)	114 (4.49)	189 (7.44)	89 (3.50)	80 (3.15)
100	158 (6.22)	127 (5.00)	254 (10.00)	118 (4.65)	110 (4.33)

Dimensions in mm (inch)

Modules DN 150 ... DN 200

KOF = Tapered flange (with raised face and groove for O-ring)

ZWF = Intermediate flange (with recessed face)

①

Air filter (open)
with flange

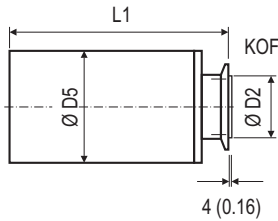

②

10 x D inlet section
with flanges
(on both sides)

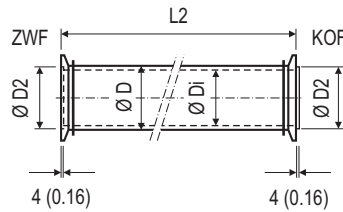

③

5 x D outlet section
with flanges
(on both sides)

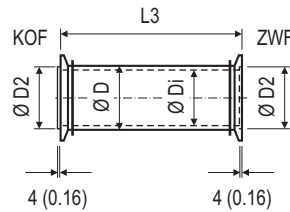

④

Hose adapter
with flange
(on one side)

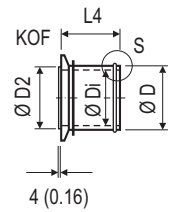

⑦

Flow conditioner
with flange

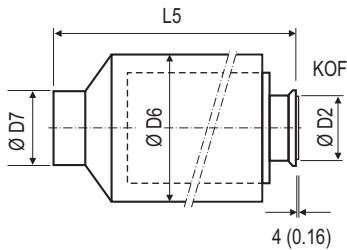

④

10 x D inlet section
with flange
(on one side)

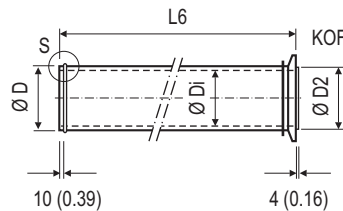

⑤

5 x D outlet section
with flange
(on one side)

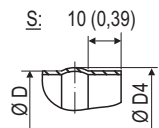
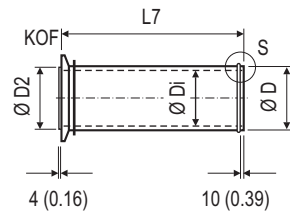

Standard measuring section

Measuring section 3
(Flow conditioner)

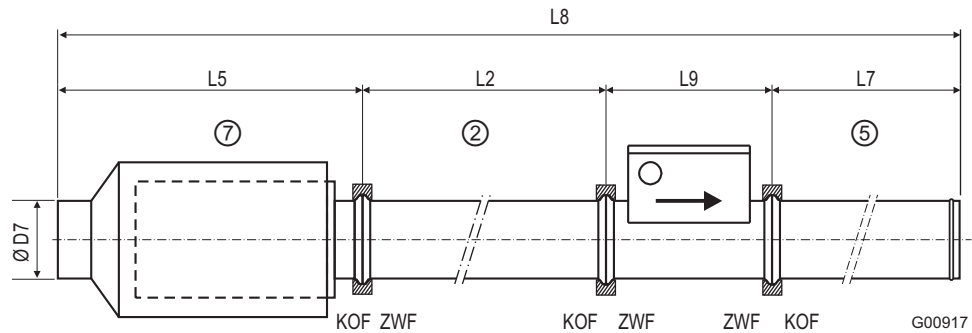

Fig. 35: Dimensions in mm (inch)

DN	L1	L2	L3	L4	L5	L6	L7	L8	L9
150	appr. 513 (20.20)	1518 (59.76)	768 (30.24)	159 (6.26)	appr. 900 (35.43)	1509 (59.41)	759 (29.88)	appr. 3460 (136.22)	280 (11.02)
200	appr. 513 (20.20)	2018 (79.49)	1018 (40.08)	159 (6.26)	appr. 850 (33.46)	2009 (79.09)	1018 (40.08)	appr. 4220 (166.14)	330 (12.99)

DN	Ø D	Ø D2	Ø D4	Ø D5	Ø D6	Ø D7	Ø Di
150	151 (5.94)	158 (6.22)	153 (6.02)	appr. 300 (11.81)	appr. 350 (13.78)	198 (7.80)	149 (5.87)
200	202 (7.95)	205 (8.07)	204 (8.03)	appr. 300 (11.81)	appr. 350 (13.78)	248 (9.76)	200 (7.87)

Dimensions in mm (inch)

Modules DN 150 ... DN 200

KOF = Tapered flange (with raised face and groove for O-ring)

ZWF = Intermediate flange (with recessed face)

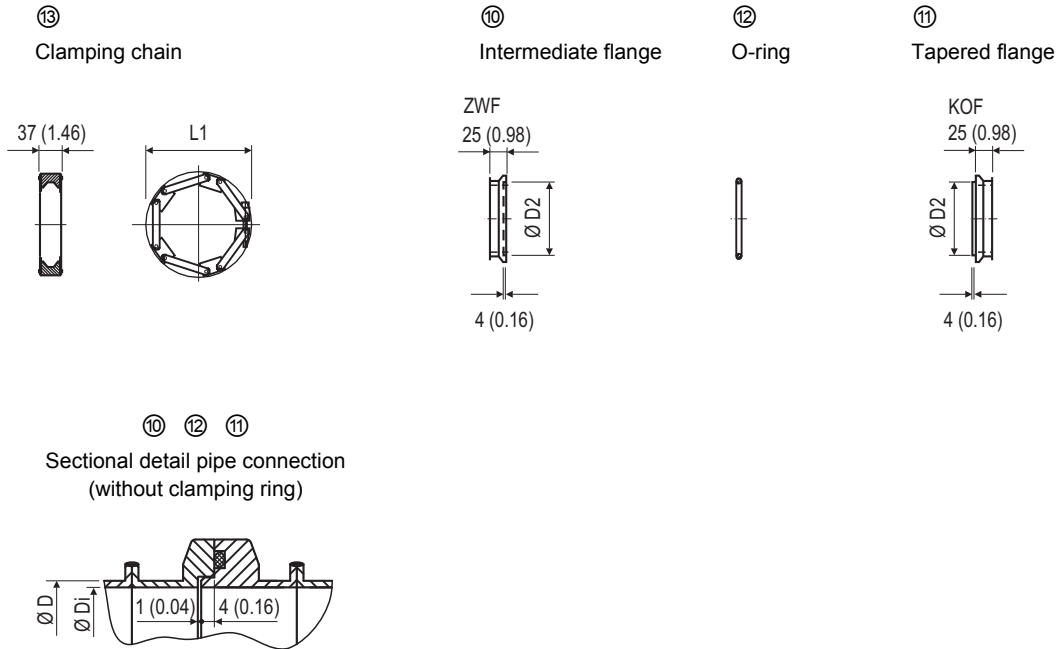

Individual planning

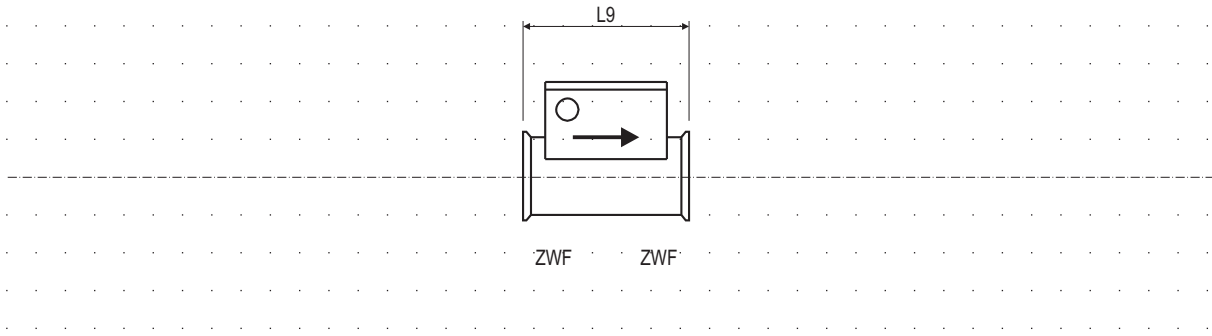

G00921

Fig. 36: Dimensions in mm (inch)

DN	L1	L9	Ø D	Ø Di
150	appr. 220 (8.66)	280 (11.02)	151 (5.94)	149 (5.87)
200	appr. 280 (11.02)	330 (12.99)	202 (7.95)	200 (7.87)

Dimensions in mm (inch)

10 Appendix

10.1 Decommissioning and packaging

Packaging the device ready for transport or return to the manufacturer

If the original packaging material is no longer available, wrap the device in bubble wrap or corrugated cardboard and place it in a box of sufficient size lined with a shock-absorbing material (e.g., foam rubber). The thickness of the padding should be appropriate for the device weight and type of shipment. The box must be handled with care and labeled accordingly.

For overseas shipment, always add a desiccant (e.g., silica gel) and hermetically seal the device plus desiccant in a layer of polythene that is 0.2 mm thick. Use an amount of desiccant that is appropriate for the packing volume and the expected transport time (at least sufficient for 3 months). You should also line the box with a layer of union paper.

All devices returned to the manufacturer must be accompanied by a completed and signed decontamination certificate (see Appendix). Without this, ABB will not be able to process the return.

10.2 Other applicable documents

- Data Sheet 10/14-6.84

10.3 Approvals and certifications

CE mark		The version of the meter in your possession meets the requirements of the following European directives: <ul style="list-style-type: none"> - EMC directive 2004/108/EC - Low voltage directive 2006/95/EC
---------	------------------------------------------------------------------------------------	------------------------------------------------------------------------------------------------------------------------------------------------------------------------------------------------------------------------------------



IMPORTANT (NOTE)

All documentation, declarations of conformity and certificates are available in ABB's download area.

www.abb.com/flow

10.4 Declaration of conformity

EG-Konformitätserklärung
EC-Certificate of Compliance

Hiermit bestätigen wir die Übereinstimmung der aufgeführten Geräte mit den Richtlinien des Rates der Europäischen Gemeinschaft, welche mit dem CE- Zeichen gekennzeichnet sind.

Die Sicherheits- und Installationshinweise der Produktdokumentation sind zu beachten.
We herewith confirm that the listed devices are in compliance with the council directives of the European Community and are marked with the CE- marking. The safety and installation requirements of the product documentation must be observed.

Hersteller: ABB Automation Products GmbH,
 Manufacturer: Dransfelder Straße 2, 37079 Göttingen - Germany

Gerät: Thermischer Massen Durchflussmesser
 Device: Thermal Mass Flowmeter

Modelle.: Sensyflow FMT700-P
 Models:

Produktnummer: V14243-...
 Models:

Richtlinie: 2004/108/EG* (EMV)
 Directive: 2004/108/EC* (EMC)

Europäische Norm: EN 61326-1, 10/2006* EN 61326-2-3, 05/2007*
 European Standard: EN 61326-1, 10/2006* EN 61326-2-3, 05/2007*

Richtlinie: 2006/95/EG* (Niederspannungsrichtlinie)
 Directive: 2006/95/EC* (Low voltage directive)

Europäische Norm: EN 61010-1, 01/2009*
 European Standard: EN 61010-1, 01/2009*

* einschließlich Nachträge / including alterations

Göttingen, 01. Dezember 2011



i.V. Klaus Schäfer
 (QM Manager)



i.V. Dr. Günter Kuhlmann
 (R&D Manager)

BZ-13-5116
 Rev.01

ABB Automation Products GmbH

Postanschrift:
 Dransfelder Str. 2
 D-37079 Göttingen

Besuchsanschrift:
 Dransfelder Str. 2
 D-37079 Göttingen

Telefon +49 551 905 0
 Telefax +49 551 905 777
 Internet: <http://www.abb.com/de>

Statement on the contamination of devices and components

Repair and / or maintenance work will only be performed on devices and components if a statement form has been completed and submitted.

Otherwise, the device / component returned may be rejected. This statement form may only be completed and signed by authorized specialist personnel employed by the operator.

Customer details:

Company: _____

Address: _____

Contact person: _____

Telephone: _____

Fax: _____

E-mail: _____

Device details:

Type: _____

Serial no.: _____

Reason for the return/description of the defect: _____

Was this device used in conjunction with substances which pose a threat or risk to health? Yes No

If yes, which type of contamination (please place an X next to the applicable items)?

Biological Corrosive / irritating Combustible (highly / extremely combustible) Toxic Explosive Other toxic substances Radioactive

Which substances have come into contact with the device?

1. _____

2. _____

3. _____

We hereby state that the devices / components shipped have been cleaned and are free from any dangerous or poisonous substances.

Town/city, date_____
Signature and company stamp

ABB has Sales & Customer Support expertise in over 100 countries worldwide.

www.abb.com/flow

The Company's policy is one of continuous product improvement and the right is reserved to modify the information contained herein without notice.

Printed in the Fed. Rep. of Germany (12.2011)

© ABB 2011

3KXF421006R4201



ABB Limited

Oldends Lane, Stonehouse
Gloucestershire, GL10 3TA
UK

Tel: +44 (0)1453 826661
Fax: +44 (0)1453 829671

ABB Inc.

125 E. County Line Road
Warminster, PA 18974
USA

Tel: +1 215 674 6000
Fax: +1 215 674 7183

ABB Automation Products GmbH

Dransfelder Str. 2
37079 Goettingen
Germany

Tel: +49 551 905-534
Fax: +49 551 905-555