



FM Approvals
1151 Boston-Providence Turnpike
P.O. Box 9102 Norwood, MA 02062 USA
T: 781 762 4300 F: 781 762 9375 www.fmglobal.com

CERTIFICATE OF COMPLIANCE

HAZARDOUS (CLASSIFIED) LOCATION ELECTRICAL EQUIPMENT

This certificate is issued for the following equipment:

V18348- a0b4d3efghi. TZID-C200 Positioner

IS/I, II, III/1/ABCDEFG/T4 Ta = 85 °C- 901176; Entity;
NI/I, II, III/2/ABCD/F/T4 Ta = 85 °C;
Type 4X

Max. Entity Parameters: Per Control 901176

- a = Case/Mounting 1, 2, 3, 4, 5 or 6
- b = Operator panel and display 0 or 1
- d = Output/Safe protection 1, 2, 3, 4, 5 or 7
- e = Option modules for analog or digital position feedback 0, 1, 3 or 4
- f = Mechanical kit (proximity switches) for digital position feedback/Microswitches (only for XP) 0, 1, 2, 3
- g = Parameter setting/bus address 1 or 2
- h = Design (varnish/coding) 1 or 2
- i = Device identification label 0, 1 or 2

V18348-a0b2d3efghi. TZID-C200 Positioner

XP/I /1/CD/T5 Ta = 82 °C;DIP/II,III/1/EFG/T5 Ta = 82°C; Type 4X

- a = Case/Mounting 1, 2, 3, 4, 5 or 6
- b = Operator panel and display 0 or 1
- d = Output/Safe protection 1, 2, 3, 4, 5 or 7
- e = Option modules for analog or digital position feedback 0, 1, 3 or 4
- f = Mechanical kit (proximity switches) for digital position feedback/Microswitches (only for XP) 0, 1, 2, 3
- g = Parameter setting/bus address 1 or 2
- h = Design (varnish/coding) 1 or 2
- i = Device identification label 0, 1 or 2



Equipment Ratings:

Explosion proof for Class I, , Division 1 Groups C & D, T5 Ta = 82°C; dust-ignitionproof for Class II/III, Division 1, Groups E, F and G; T5 Ta = 82°C; or as intrinsically safe for Class I, II, III, Division 1 groups A, B, C, D, E, F and G; Entity; non-incendive for use in Class I Division 2 Groups A, B, C and D, T4 Ta = 85°C; suitable for Class II and III Division 2, Groups F and G, T4 Ta = 85°C Hazardous (Classified) Locations indoor/outdoor (NEMA Type 4X

Approved for:

ABB AUTOMATION PRODUCTS GmbH
SCHILLERSTR. 72
32425 MINDEN, GERMANY



This certifies that the equipment described has been found to comply with the following FM Approval Standards and other documents:

Class 3600	1998
3610	1999
3611	1986
3810	1989
3615	1989

Original Project ID: 3010829

FM Approval Granted: November 12, 2002

Subsequent Revision Reports / Date FM Approval Amended

Report Number	Date	Report Number	Date
---------------	------	---------------	------

FM Global Technologies LLC

Nicholas P. Ludlam
Technical Team Manager

November 15, 2002
Date



CONTROL DOCUMENT NO 901176

Hazardous area
 Class I, Div. 1, Groups A, B, C, D
 Class II, Div. 1, Groups E, F, G
 Class III, Div. 1
 (Note 2)

Nonhazardous area

TZIDC-200
 VI8348-X0X4X300XXX

Associated
 Apparatus

Control
 Equipment

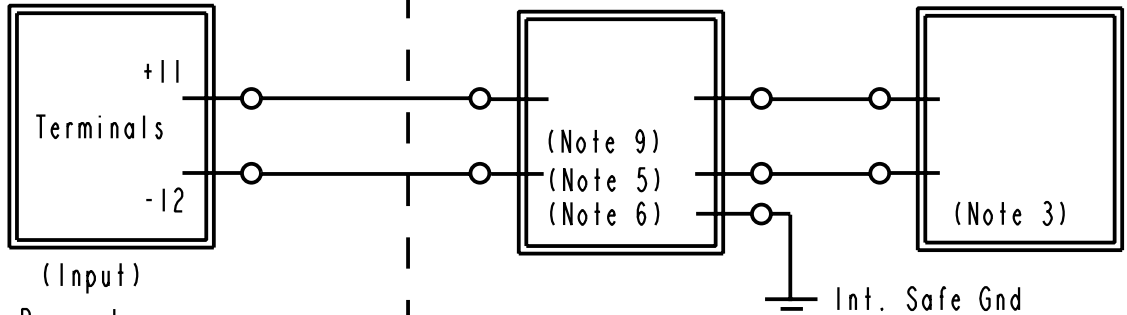

Entity Parameters:

$V_{max} = 30 \text{ Vdc}$ $I_{max} = 104 \text{ mA}$
 $C_i = 6.6 \text{ nF}$ $L_i = 0 \text{ }\mu\text{H}$
 $P_i = 1 \text{ W}$

Notes

1. V_{oc} or $V_i \leq V_{max}$, I_{sc} or $I_t \leq I_{max}$, $C_a \geq C_i + C_{cable}$, $L_a \geq L_i + L_{cable}$; $P_o \leq P_i$
2. Dust-tight conduit seal must be used when installed in Class II and Class III environments.
3. Control equipment connected to barrier must not use or generate more than 250 Vrms or Vdc
4. Installation should be in accordance with ANSI/ISA RP12.6 "Installation of Intrinsically Safe System for Hazardous (Classified) Locations" and the National Electrical Code (ANSI/NFPA 70).
5. The configuration of associated apparatus must be FMRC Approved/CSA Approved as required.
6. Associated apparatus manufacturers installation drawing must be followed when installing this equipment.
7. When connecting conduit to the enclosure use conduit hubs that have the the same environmental rating as the enclosure.
8. No revision to drawing without prior FMRC Approval/CSA Approval.
9. OUTPUT CURRENT MUST BE LIMITED BY A RESISTOR SUCH THAT THE OUTPUT VOLTAGE CURRENT PLOT IS A STRAIGHT LINE DRAWN BETWEEN OPEN CIRCUIT VOLTAGE AND SHORT CIRCUIT CURRENT.
10. Tampering and replacement with non-factory components may adversely affect the safe use of the system. Substitution of components may impair suitability for hazardous locations.
11. FOR FM DIV. 2 USE: Do not connect or disconnect unless the power was switched off or the area is known to be non hazardous.
12. Local communication interface LKS shall not be used in hazardous locations.
13. To maintain intrinsic safety, wiring associated with each channel must be run in separate cable shields connected to intrinsically safe (associated apparatus) ground.

Schutzvermerk nach DIN 34 beachten . Copyright reserved

Passmaß				Technische Oberfläche:			
Oberes Abmaß				Rev. 1 (22.08.08)			
Unteres Abmaß				WN:			
Werkstückkanten nach DIN 6784 ohne Angaben		Technische Oberfläche nach DIN ISO 1302		Allgemeintoleranzen		Gef. aus:	
				DIN ISO 2768-m-C		Sach-Nr: WN:	
		Maße in mm		Benennung		Maßstab	
				CONTROL DOCUMENT		1 : 1	
		Datum		Name			
		Bearb. 14.05.02		Lasarzik			
		Gepr.					
		ABB		Zchng.-Nr (Sach-Nr)		Blatt von	
		ABB Automation		901176 (4)		1 / 4	
Auszg.		Änderg.		Datum		Name	
				ABB Automation		Ersatz für: _	
						Gerät: _	

CONTROL DOCUMENT NO 901176

Hazardous area

Nonhazardous area

Class I, Div. 1, Groups A, B, C, D
 Class II, Div. 1, Groups E, F, G
 Class III, Div. 1
 (Note 2)

TZIDC-200
 VI8348-X0X4X301XXX
 or VI8348-X0X4X302XXX

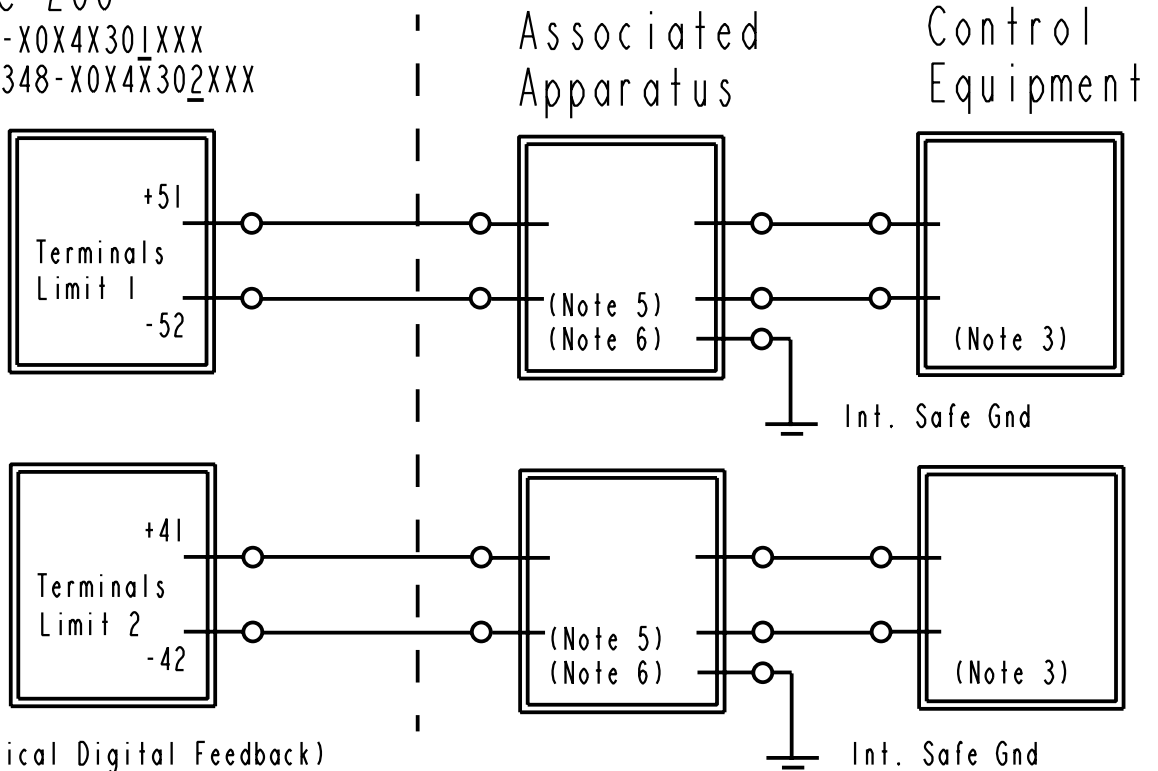

(Mechanical Digital Feedback)

Entity Parameters:

V_{max} = 15.5 V
 I_{max} = 52 mA
 C_i = 20 nF
 L_i = 30 μH
 P_i = 1 W

Schutzvermerk nach DIN 34 beachten. Copyright reserved

Passmaß				Technische Oberfläche:			
Oberes Abmaß				Rev. 1 (22.08.08)			
Unteres Abmaß				WN:			
Werkstückkanten nach DIN 6784 ohne Angaben		Technische Oberfläche nach DIN ISO 1302		Allgemeintoleranzen		Gef. aus:	
				DIN ISO 2768-mC		Sach-Nr: WN:	
		Maße in mm		Benennung		Maßstab	
				CONTROL DOCUMENT		1 : 1	
		Datum		Name			
		Bearb. 14.05.02		Lasarzik			
		Gepr.					
		ABB		Zchnng. -Nr (Sach-Nr)		Blatt von	
		ABB Automation		901176 (4)		4 / 4	
Auszg.		Änderg.		Datum		Name	
				Ersatz für: _		Gerät: _	