

Contactless temperature monitoring system FCU400-IR (SensyCal IR)

for power transmission systems



Contactless temperature monitoring system FCU400-IR (SensyCal IR) for power transmission systems

Manual

Document No. 42/18-70 EN
Edition: 12.2009
Revision: 03

Manufacturer:

ABB Automation Products GmbH
Borsigstr. 2
63755 Alzenau
Germany

Tel: +49 551 905-534
Fax: +49 551 905-555
CCC-support.deapr@de.abb.com

© Copyright 2009 by ABB Automation Products GmbH
Subject to technical changes

This technical documentation is protected by copyright. Translating, photocopying and disseminating it in any form whatsoever - even editings or excerpts thereof - especially as reprint, photomechanical or electronic reproduction or storage on data processing systems or networks is not allowed without the permission of the copyright owner and non-compliance will lead to both civil and criminal prosecution.

Inhalt	Seite
1 General safety instructions, intended use	5
1.1 Prerequisites for safe operation	5
1.2 Intended use	5
1.3 Safe operation	6
1.4 To be observed:	6
1.5 Emergencies	7
2 Components, intended use, functional principle	8
3 Mounting	9
3.1 Installation site	9
3.2 Mounting the device	9
3.2.1 Mounting the IR-Sensor	9
3.2.2 Mounting the caloric energy computer	11
4 Connecting caloric energy computer, basic unit	12
4.1 IR Sensors	14
5 Commissioning – safety instructions	15
5.1 Checking the installation	15
5.2 Connecting the power cables	15
5.3 Switching on the Device	15
6 Operation, configuration, parameterization	16
6.1 Operator panel	16
Display	16
Operating elements	16
Optical interface	16
6.2 Navigation	17
6.3 Safety levels	17
6.4 Menus	18
6.4.1 Mains Menus	18
6.4.2 Maximum values, physical variables: Menu 1 to Menu 4	19
6.4.3 Electrical variables Menu 5	20
6.4.4 Error messages Menu 6	21
6.4.5 Date/time Menu 7	22
6.4.6 Service Menu 8	23
6.4.7 Data logger Menu 9	25
6.4.8 Print function Menu10	26
6.4.9 Tag name Menu11	26
6.4.10 Device data Menu 12	27
6.4.11 Password Menu 13	28
7 Error Messages	29
7.1 Process errors	29
7.2 Device errors	29
8 Retrofitting	30
8.1 General safety instructions	30
8.2 Retrofitting option modules	30
9 Maintenance	31
9.1 Safety instructions	31
9.2 Replacing fuse	31

10 Technical data	32
10.1 IR-Sensor CS	32
10.2 Caloric energy computer	33
Input	33
Output	33
Interfaces	33
Characteristic values	33
Operating conditions	33
Design features	34
Display and GUI	34
Data logger	34
Power supply, whole system	34
Error reporting and error output	34
11 Configuration and communication program	35
12 Putting out of service and packaging	35
Packaging for transport or return to the manufacturer	35

1 General safety instructions, intended use

1.1 Prerequisites for safe operation

In these instructions SensyCal® IR is consistently referred to as 'the device'. These instructions contain important information about safe and proper operation of the device. Follow these instructions to ensure safe operation. Ignoring the safety instructions can result in death, injuries, or damages to the device itself or other devices and equipment.

Make sure that

- the device is in a proper condition
- the device is used properly and in accordance with the intended use
- you know and observe all safety instructions and are aware of all potential risks
- you follow all instructions in this manual.

Read these instructions prior to commissioning or maintaining/repairing the device or putting it out of service.

Target groups

The information in this manual is intended for

- the operator/owner
- the installing engineer
- the commissioning engineer
- the user

Qualification of the personnel

Only qualified personnel who are familiar with mounting, installing, commissioning, operating and maintaining this device or similar devices are allowed to work on the device.

Observe

- the information in these instructions
- the safety instructions on the labels attached to the device
- the relevant safety regulations and standards for the installation and operation of electrical systems.

1.2 Intended use

The device is intended to be used for monitoring the temperature of power transmission systems.

Observe

- the commissioning instructions,
- the operating instructions,
- the instructions for putting the device out of service,
- the maintenance and repair instructions and
- the instructions for proper disposal
- to ensure proper use as intended.

Observe the "Technical Data" of the device. These can be found in the respective section of this manual or in the appropriate data sheets.

Operator/owner





The operator/owner of the plant must ensure proper and safe operation through qualified personnel and is fully liable for this.

The operator/owner must make sure that these instructions are read and understood by the persons of the target groups. A copy of these instructions must be stored permanently in the appropriate place on the mounting site of the device. The standards, regulations and directives referred to in these operating instructions are valid in Germany. When using the device outside the scope of validity of the German standards and regulations the appropriate and valid regulations of the respective country must be observed.

1.3 Safe operation

The device is in accordance with the state of the art. It has been designed and tested in accordance with DIN EN 61 010 Part 1/IEC 10 10-1 "Safety Requirements for Electrical Measuring, Control and Laboratory Apparatus" and has been supplied in a safe condition. In order to retain the device in a safe condition and to ensure safe operation the safety instructions in this manual marked with the appropriate symbol must be observed. Otherwise, persons can be endangered or the device itself or other devices or equipment may be damaged or fail.

The safety instructions are marked with symbols, which have the following meaning:

Symbol	Signal Word	Definitions
	DANGER	DANGER indicates an imminently hazardous situation which, if not avoided, will result in death or serious injury. (High level of risk.)
	WARNING	WARNING indicates a potentially hazardous situation which, if not avoided, could result in death or serious injury. (Medium level of risk.)
	CAUTION	CAUTION indicates a potentially hazardous situation which, if not avoided, could result in minor or moderate injury. (Low level of risk.)
	NOTICE	NOTICE indicates a potentially harmful situation which, if not avoided, may result in damage of the product itself or of adjacent objects. (Damage to property)
	IMPORTANT	IMPORTANT indicates useful hints or other special information which, if not observed, could lead to a decline in operating convenience or affect the functionality. (Does not indicate a dangerous or harmful situation.)

Observe the information labels in the operator's/owner's workshop and the labels attached to the devices.

1.4 To be observed:

Prior to mounting

Perform all mounting/installation work in the least dangerous area. The mounting site must meet the requirements specified in Section "Technical Data" under "Operating Conditions", Environmental specifications".

Prior to commissioning or putting back to service

The following steps must be performed to comply with these instructions:

- Commissioning,
- Putting out of service
- Putting back to service

Prior to commissioning the device or putting it back to service always check that the mains voltage applied to the device is in accordance with the voltage specified on the rating plate.

Prior to commissioning the operator/owner must make sure that the system is checked and tested by an expert for electricity matters for

- proper mounting
- proper installation
- proper operation
- fire alarm and fire fighting equipment

During operation

The operator/owner must make sure that the system is checked and tested periodically by an expert for electricity matters for

- proper mounting,
- proper installation
- proper operation

The checking intervals must be defined such that any defects that are likely to occur are recognized in good time.

The checks must be performed every three years at the latest. If the electrical system is permanently monitored and checked by the engineer in charge, the periodic check can be omitted.

The operator/owner is obliged to

- keep the system in a proper condition
- make sure that the plant is permanently monitored
- see to it that the necessary maintenance and repair work is carried out immediately
- see to it that the necessary precautions are taken.

Maintenance and repair

Prior to performing any maintenance or repair work on the electrical systems or devices always disconnect the systems or devices from the mains. The point of separation must be marked with the appropriate warning sign, e.g.

System under repair/out of service

Do not switch on

Spare parts

Use genuine spare parts, only.

1.5 Emergencies



DANGER

In cases of emergency immediately switch off the system/plant using the emergency switch.

2 Components, intended use, functional principle



Fig. 2-1 FCU400-IR (SensyCal IR) is designed for monitoring the temperature of power transmission systems

FCU400-IR (SensyCal IR) consists of

- non-contact thermometers for temperature measurement on contact points and conductor rails, hereinafter referred to as "IR-Sensors".
- a data processing and display unit for the measured variables and electric variables, in the following text called a "caloric energy computer", and an additional metal housing for optimal protection against electromagnetic interference.
- Pt100 resistance thermometers (optional) for measuring the ambient temperature at the mounting site.

The thermometer detects any excess temperature and generates a pre-alarm or main alarm when a limit value is exceeded.

Additionally can each temperature and the maximum temperature readout with RS 232/RS 485-card (optional) via MODBUS protocol. Alternative can the maximum value output via the output-card (optional) as mA-output.

IR-Sensor operating principle:

Contactless temperature measurement is based on the fact that all bodies emit heat radiation, depending on their temperature. IR-Sensors are capable of measuring the intensity of the heat radiation received. This intensity is a measure for the temperature of the contact point or the conductor rail.

	<p>CAUTION Important! Do not use bright metal surfaces for temperature measurement! Usually, bright metal surfaces reflect perturbing radiation from the environment to a large extent. Therefore, such surfaces are not suitable for contactless temperature measurement at all. Use varnished or plastic-coated surfaces instead. All kinds of varnish except those containing metal particles are permissible.</p>
---	--

The caloric energy computer consists of the following components:

- Power supply unit, graphic display and processing electronics
- up to 12 analog mV inputs and 1 input for Pt100
- 3 digital outputs for alarm, prealarm and error signalling
- M-Bus interface
- RS 232/RS 485 card (optional) or alternative
- mA output card (optional)

3 Mounting

3.1 Installation site

The installation site and mounting orientation must be in accordance with the following specifications:

Operating conditions, environmental capabilities

Ambient temperature	-5 ... +55 °C
Storage temperature	-25 ... +70 °C
Climate class	ambient temperature class C to EN 1434-1
Relative humidity	tested to EN 1434-4, IEC 62-2-30
Condensation	permissible
Protection class	IP 40
Resistance to shock during operation (at 20 °C)	to IEC 68-2-6 or 68-2-27
Vibration	2g/10 ... 150 Hz
Shock	30g/11 ms/3 shocks

Electromagnetic compatibility (EMC)

Immunity to EMI/RFI	to EN 50082-2 (EN 6100-4-2, -3, -4, -5,6) and to EN 1434-4 (Class C)
RFI suppression	to EN 50081-2 (EN 55011 Class A)

Test type	Standard	Inspection level	Influence
Surge to AC supply com diff.	EN 61000-4-5	2 kV 1 kV	no effect no effect
Burst to supply lines	EN 61000-4-4	2 kV	< 0.2 %
Burst to signal lines	EN 61000-4-4	1 kV	< 0.2 %
Electrostatic discharge, contacts	EN 61000-4-2	6 kV	< 0.2 %
Radiated emissions (80-1000 MHz)	EN 61000-4-3	10 V/m	< 0.2 %
Conducted immunity (150 kHz ... 80 MHz)	EN 61000-4-6	10 V	met
Mains failure / variation	EN 61000-4-411		
RFI suppression	Limit class met		
Noise voltage on supply line	EN 55022	A	
Intensity of noise field	EN 55022	B	

The device is designed for panel mounting and for mounting on 35 mm top hat rails.

3.2 Mounting the device

3.2.1 Mounting the IR-Sensor

The IR-Sensor CS is equipped with a metric M12 x 1 thread and can be installed either directly via the sensor thread or with the help of the both hex nuts (standard) to the mounting bracket available.

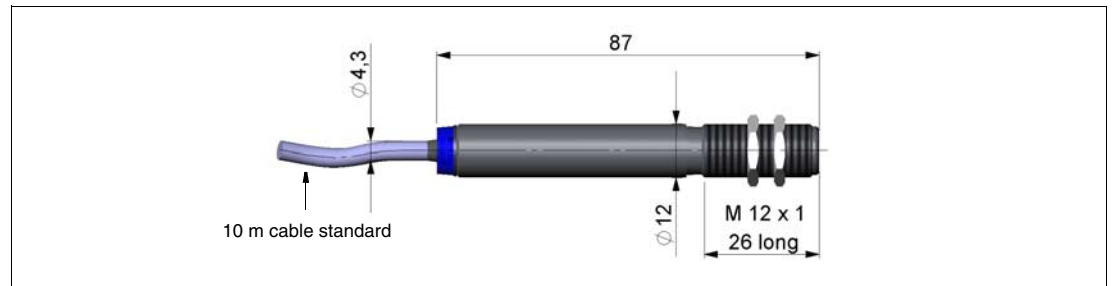

Fig. 3-1 IR-Sensor dimensions

Optical charts

The following optical charts show the diameter of the measuring spot in dependence on the distance between measuring object and sensing head. The spot size refers to 90 % of the radiation energy. The spot size is always measured from the front edge of the sensor housing/CF lens holder/air purge.

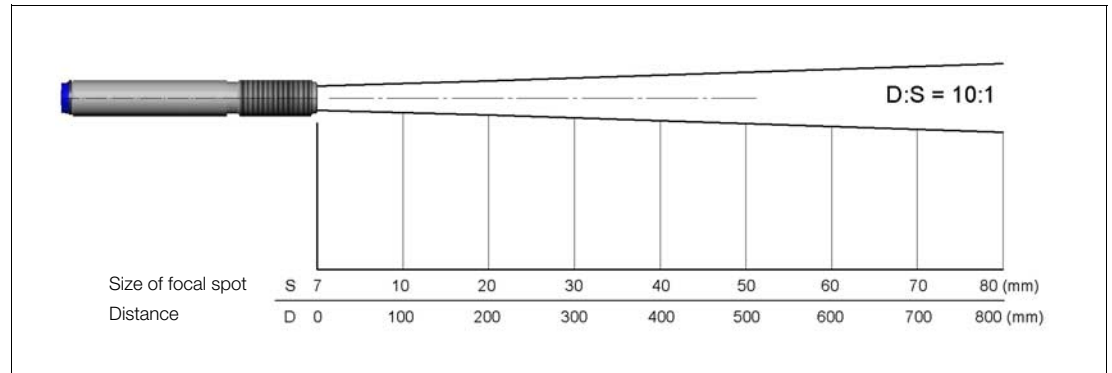



Fig. 3-2 Optical chart IR-Sensor CS (10:1)

The size of the measuring object and the optical resolution of the infrared thermometer determine the maximum distance between sensing head and measuring object.

In order to prevent measuring errors the object should fill out the field of view of the optics completely. Consequently, the spot should at all times have at least the same size like the object or should be smaller than that.

	<p>NOTICE Make sure that the IR-Sensor housing is connected to the same electrical potential as the cabinet.</p>
---	---

Selecting the measuring point

Consider the following selection criteria:

- Insulation gap between energized conductor rail and IR-Sensors
- Focal spot in dependence of the distance:
Correct temperature measurement requires that the sensor can “see“ the energized objects completely. The relation between the size of the focal spot and the distance is seen in the optical diagram to the left.

Mounting the sensors

1. Drill a hole of M12 x 1 into the partition
2. Undo the foremost sensor nut
3. Place the sensor in its fitting position
4. Fasten the sensor using the conternut
5. Lay the connection cable between the sensor and SensyCal in cable ducts
6. Following the instructions in Section 4.2 to connect the IR-Sensor to the caloric energy computer

	<p>NOTICE The CS sensor are a sensitive optical system. Please use only the thread for mechanical installation. Avoid mechanical violence on the head – this may destroy the system (expiry of warranty).</p>
---	--

3.2.2 Mounting the caloric energy computer

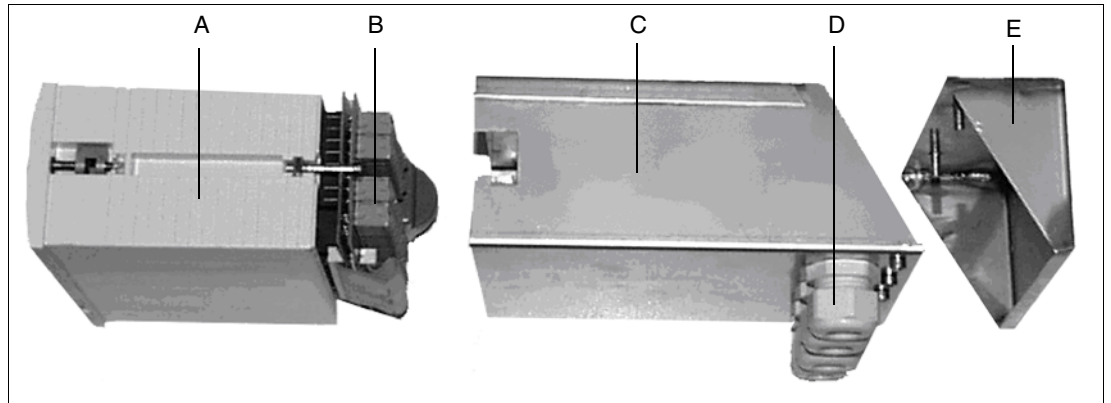

Fig. 3-3 Components of the caloric energy computer
 Basically, the device consists of the following parts:
 A) Caloric energy computer - basic unit
 B) Connector block
 C) EMC protection housing (frame)
 D) Cable bushing
 E) EMC protection housing (rear part)

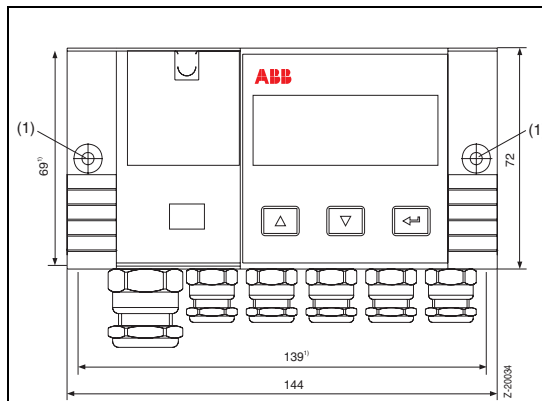

Fig. 3-4 Dimensional drawing, front view
 (dimensions in mm, cover removed)
 1 Fastening screws

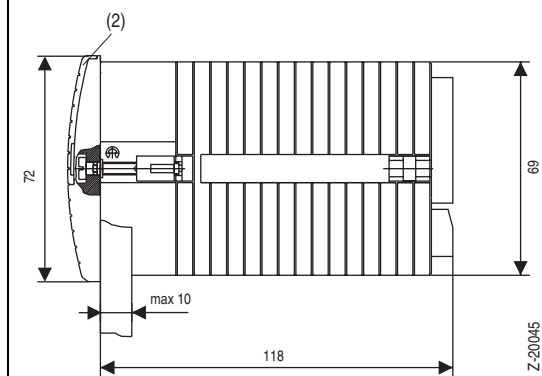
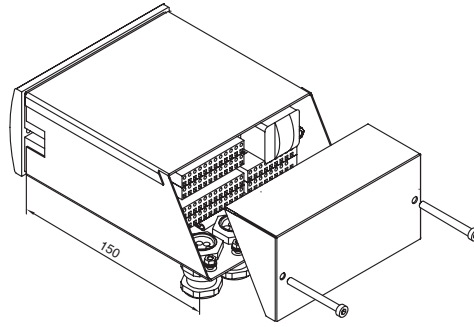

Fig. 3-5 Dimensional drawing, side view
 EMC protection housing removed
 2 Covers
 (dimensions in mm)

Mounting the device into the door of the secondary compartment.

1. Prepare a panel cutout, 139 mm x 69 mm.
2. Remove the small covers 2 on the left and right side of the basic unit to be able to access the fastening screws 1.
3. Insert the basic unit into the panel from the front.
4. Fasten the basic unit to the panel using the fastening screws 1.
5. Replace the covers 2.
6. Slide the EMC protection housing onto the caloric energy computer from the back.
7. Insert the signal and power cables (observe the safety instructions and the instructions in Section "Connecting" on page 4 and the following pages) through the cable bushing into the EMC protection housing (free cable length in the rear part of the housing is around 50 mm):
8. Put on the rear fastening screws on the back side
9. Fasten the rear part of the housing to the device using the fastening screws.
10. Establish the equipotential bonding with the cabinet



Pin No.	Sensors	
60	+	IR-Sensor #1
61	-	
62	+	IR-Sensor #2
63	-	
64	+	IR-Sensor #3
65	-	
66	+	IR-Sensor #4
67	-	
70	+	IR-Sensor #5
71	-	
72	+	IR-Sensor #6
73	-	
74	+	IR-Sensor #7
75	-	
76	+	IR-Sensor #8
77	-	
80	+	IR-Sensor #9
81	-	
82	+	IR-Sensor #10
83	-	
84	+	IR-Sensor #11
85	-	
86	+	IR-Sensor #12
87	-	

Pin No.	MODBUS (optional)	SUB D 9 pol.
90	RS 232 GND	5
91	RS 232 GxD	2
92	RS 232 RxD	3
94	RS 485 +TxD/RxD	3
95	RS 485 -TxD/RxD	8
97	RS 485 GND	5

Pin No.	mA output (optional)
90	
91	

Pin No.	Alarms	
52	+	Error output
53	-	
18	+	Pre Alarm Alarm output
19	-	
16	+	Alarm output
17	-	
93	+ B	RS 485 (termination)
96	- B	RS 485 (termination)

Pin No.	Pt 100
1	
5	
6	
2	

Pin No.	Supply	
28	+	24 V DC
27	-	

Pin No.	Bus
24	M-Bus
25	

4.1 IR Sensors

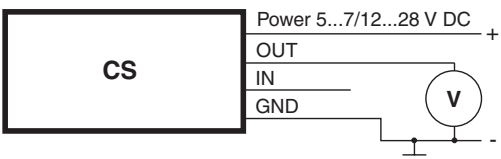



Fig. 4-2 connection cable, color mode:

white	Power
yellow	OUT
green	IN
brown	GND



NOTICE
The output impedance must be $\geq 10\text{ k}\Omega$.

1. Mount the IR-Sensor at the measuring point.
2. Lay a connection cable of 10 m of length to the caloric energy computer.
3. If the cable is too long, please cut to length.
4. Strip off the insulation over a length of around 15 cm.
5. Provide the wires with wire end sleeves or tinplate them accordingly.
6. Insert the cables through the cable bushings (IR-Sensors 1 ... 12).
7. Connect the shielding wire to the strain relief.
8. Connect the signal cables to the appropriate connectors of the basic unit. Connect the power supply th the appropriate terminals on the rear side of the EMC protection housing as seen in the illustration.

Connection diagram FCU400-IR (SensyCal IR)

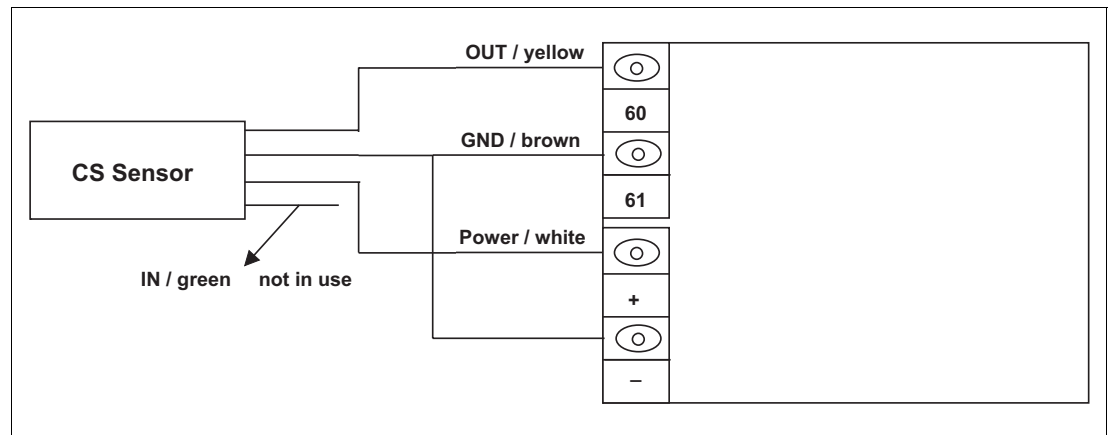

Fig. 4-3 Example for connection the IR-Sensor CS on input 1

5 Commissioning – safety instructions

Prerequisites

Prior to commissioning the device must be mounted properly, and the signal cables must be connected as specified.

5.1 Checking the installation

Prior to commissioning the device make sure that it has been installed properly. Follow the check list:

<p>Check</p> <ol style="list-style-type: none"> 1. Has the device been fastened properly and reliably? 2. Have all electrical signal, control and interface cables been laid and connected properly?
--

5.2 Connecting the power cables



CAUTION

When selecting the cables and making the electrical installation observe the standards, regulations and devices for power installations of up to 1000 V applicable and valid in the country where the device is used.

Prior to connecting the power supply make sure that the operating voltage selected on the device is identical with the local mains voltage.

Prior to making any other connections first set up a ground connection between the grounding connector on the device and protective ground.

Provide an all-pole mains switch with sufficient breaking capacity close to the mounting site for disconnecting the device from the mains if required. Make sure the switch does not eliminate the protective capacity of the equipment grounding conductor.



DANGER

Avoid any unintentional cut of the equipment grounding conductor inside or outside the device. Do not disconnect the device from protective ground. Otherwise, a serious safety hazard will occur.

When powering the device with 24 V DC exclusively use extra low voltage with protective separation from other circuits (German standard DIN VDE 0106). Do not connect mains voltage (115 V AC or 230 V AC) to the 24-V-DC input. This will damage the device electronics.

The rated current intensity of the overcurrent protector must not exceed 16 A on the installation side.

5.3 Switching on the Device



CAUTION

Prior to switching on the device make sure that all tasks specified in Section 5.2 were performed properly.

Check again that the operating voltage setting on the device complies with the local mains voltage.

Operational check

After switch-on the device automatically starts operation and can be controlled, configured, and parameterized as required.

Date and Time

Proper date and time setting are vital to proper operation of the device. Check if the date and time need to be set.

Refer to Section 6.4.5 for details about date/time setting.

The built-in supercup capacitor retains the date and time setting for more than three days.

6 Operation, configuration, parameterization

6.1 Operator panel

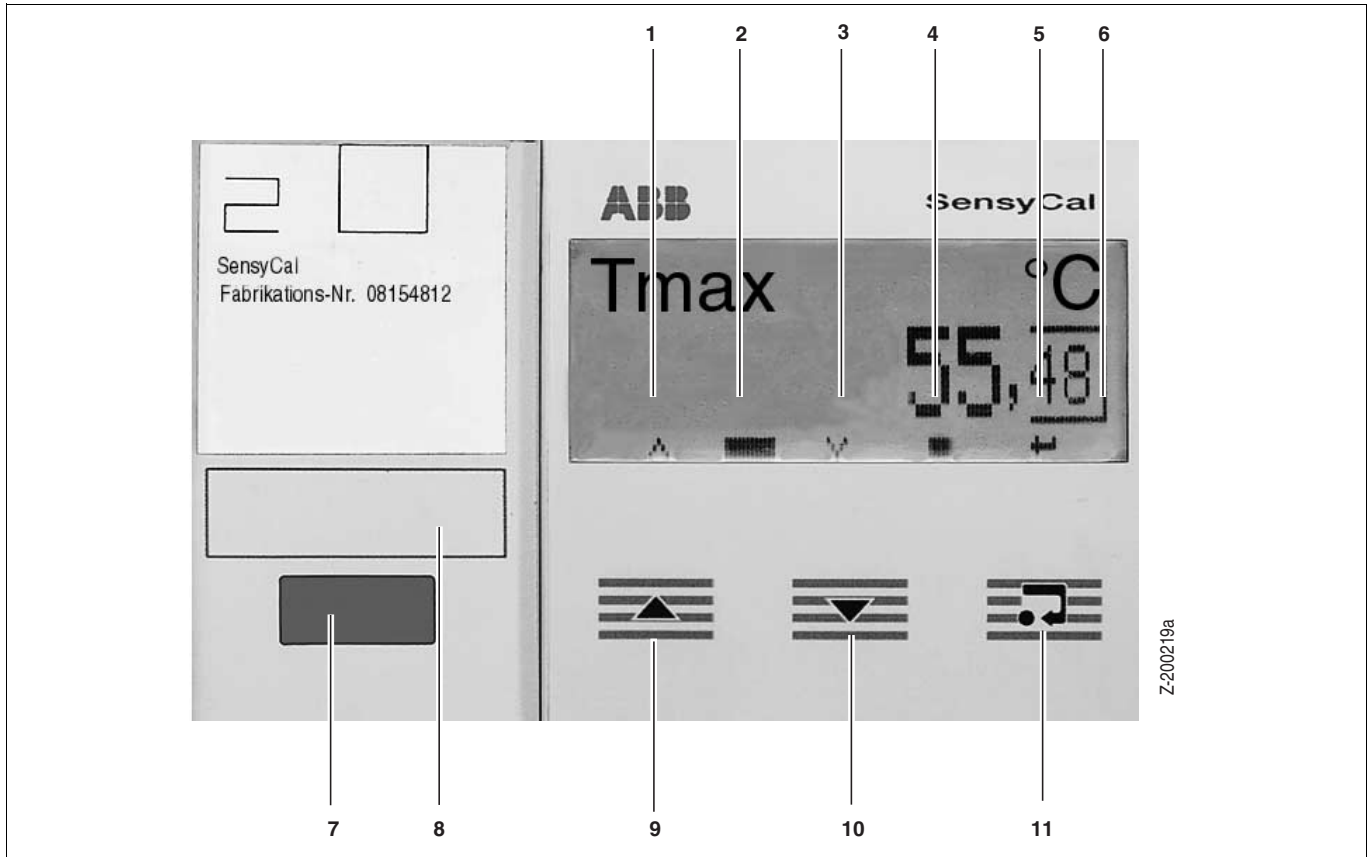

Fig. 6-1 Operator panel

Display			Operating elements		
Please refer to the "Menus" section for details about the individual displays. The symbols in the bottom part of the display always have the following meaning:			Keys		
No.	Symbol	Description	No.	Symbol	Function
1	v	Key <▲> (increment) is active	9	<▲>	Previous / increment returns to the previous menu item increment to the next digit
2	■	Changing width means that the device is working	10	<▼>	Next / decrement changes to the next menu item decrements to the previous digit
3	^	Key <▼> (decrement) is active	11	<↵>	Enter changes over from a main menu item to a submenu, enables changes of the value, switches to the next value exits the submenu.
4	■	Error message is present	Note		
5	↵	Key <↵> is available	Pressing and holding a key will repeat the respective function (with time delay for <↵>).		
6	■	EEPROM write action in progress on the right side, not seen in this photo	Optical interface		
			7	Optical interface for IRDA or ZVEI	
			8	Inscription field (use waterproof pens)	

6.2 Navigation

- Press <▼> or <▲> to select a main menu.
- Press <↵> to select the first submenu of that main menu item.
- Press <▼> or <▲> to select a submenu.

If one or several value(s) can be edited in a submenu, the first value can be activated for change by pressing <↵>. The first digit of that value starts flashing. Press <↵> to confirm the new value of this digit and call the next digit or value.

- Press <▼> or <▲> to decrement/increment the value of the first digit.
- Press <↵> to select the second digit.
- Press <▼> or <▲> to decrement/increment the value of the second digit.
- Press <▼> or <▲> to select the next submenu (if no other digit is flashing).
- Press <▼> or <▲> to select the last submenu („End submenu“).
- Press <↵> to return to the main menu.

6.3 Safety levels

The device has four safety levels.

- **Safety level S1**
The submenus of safety level S1 are only accessible for manufacturing or service personnel.
- **Safety level S2** (see submenu 8.4...)
The submenus of safety level S2 can only be accessed by setting Jumper J accordingly (see Figure 8-1) and entering a password.
- **Safety level S3** (see submenu 12.2 ...)
The submenus of safety level S3 are password-protected.
- **Safety level S4** (lowest safety, not marked in the display)
The submenus of safety level S4 are always accessible.

6.4 Menus

6.4.1 Mains Menus

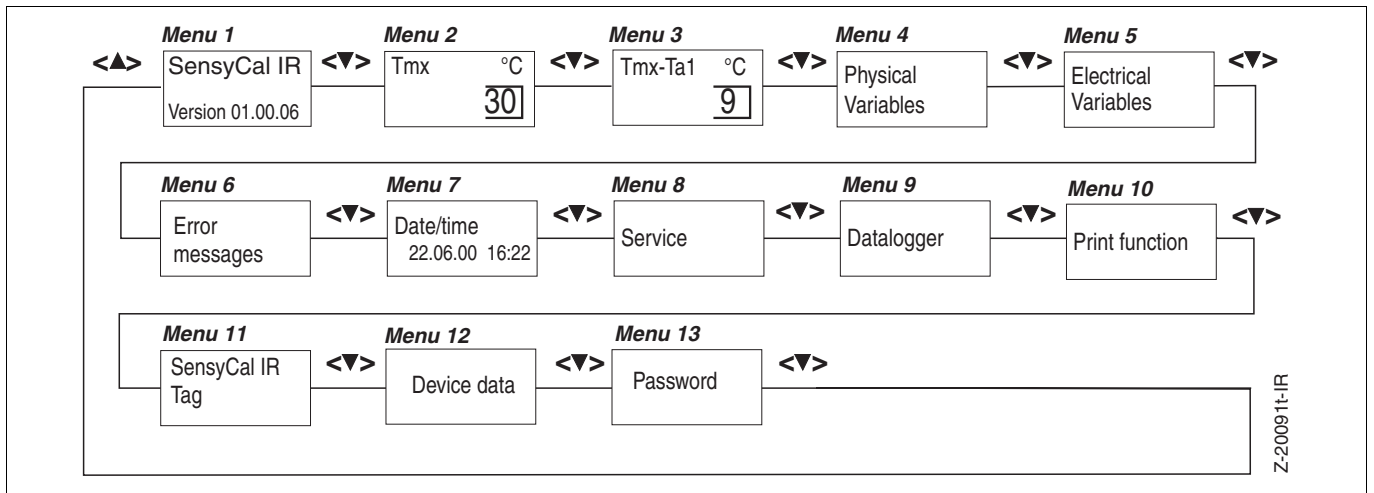

Fig. 6-2 Main menus

Delivery State

The device is set to safety level 4 when it is delivered, i.e.

- no password is set (0000)
- jumper J (see Figure 11) is set.

All menus and submenus are visible and accessible.

Upon device switch-on Menu 1 pops up in the display.

Selecting a Menu

Press <▼> to navigate through the main menu items from the left to the right or

Press <▲> to navigate through the main menu items from the right to the left.

Press <↵> to select the first submenu of the highlighted main menu item.

Entering Values

In some submenus you can edit or enter values, e.g. password, date, M-Bus address, etc. Proceed as described below (see also Section 6.1.2 "Navigation"):

1. Press <↵> to select the first digit. The first digit starts flashing.
2. Press <▲> to increment or <▼> to decrement the indicated value.
3. Press <↵> to move the cursor to the next digit. The next digit starts flashing.
4. Press <▲> to increment or <▼> to decrement the indicated value, and so on.
5. After setting the last digit press <↵> to exit the input mode.
6. Press <▼> to select the next or <▲> to select the previous submenu.

6.4.2 Maximum values, physical variables: *Menu 1 to Menu 4*

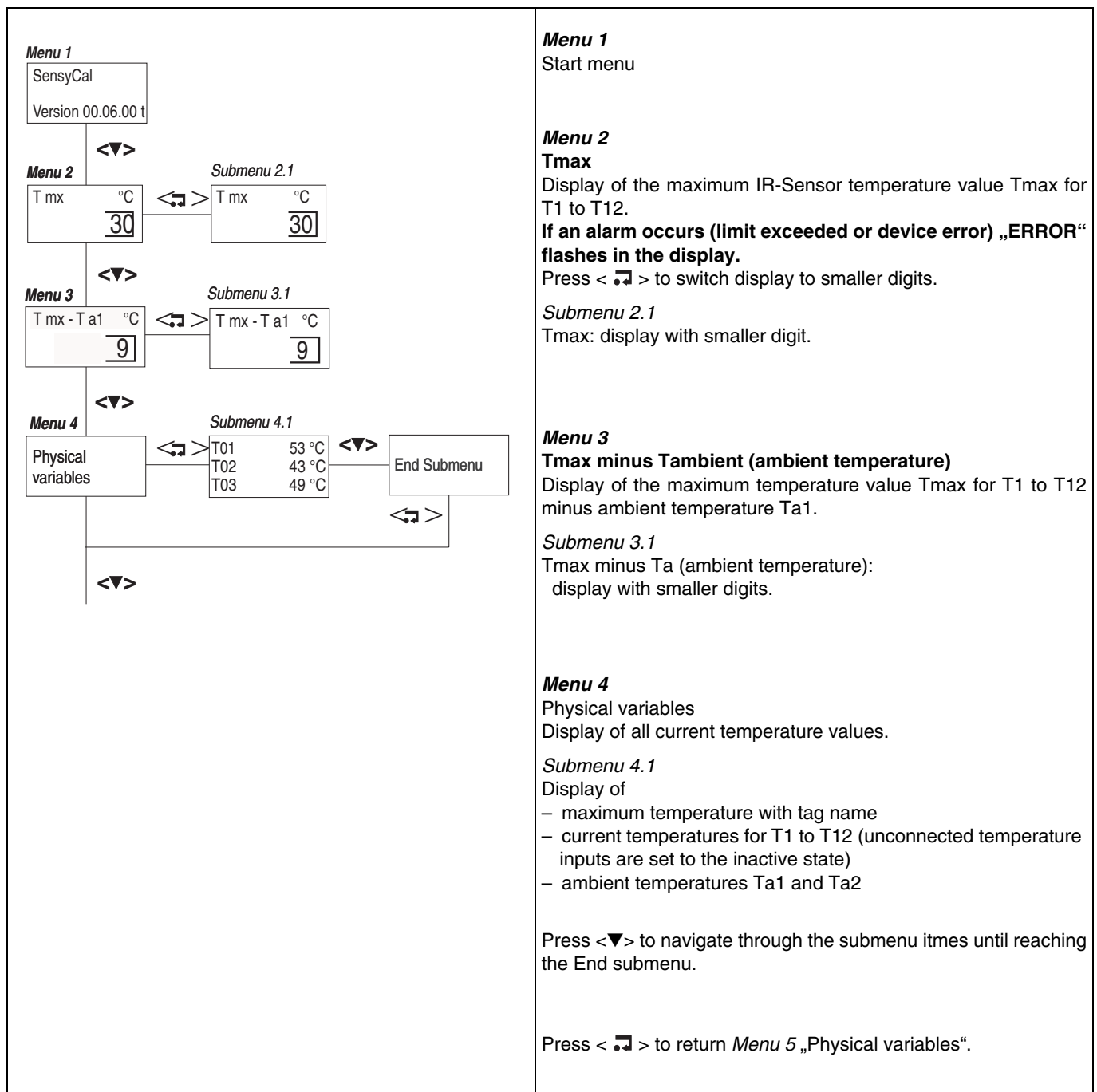

6.4.3 Electrical variables Menu 5

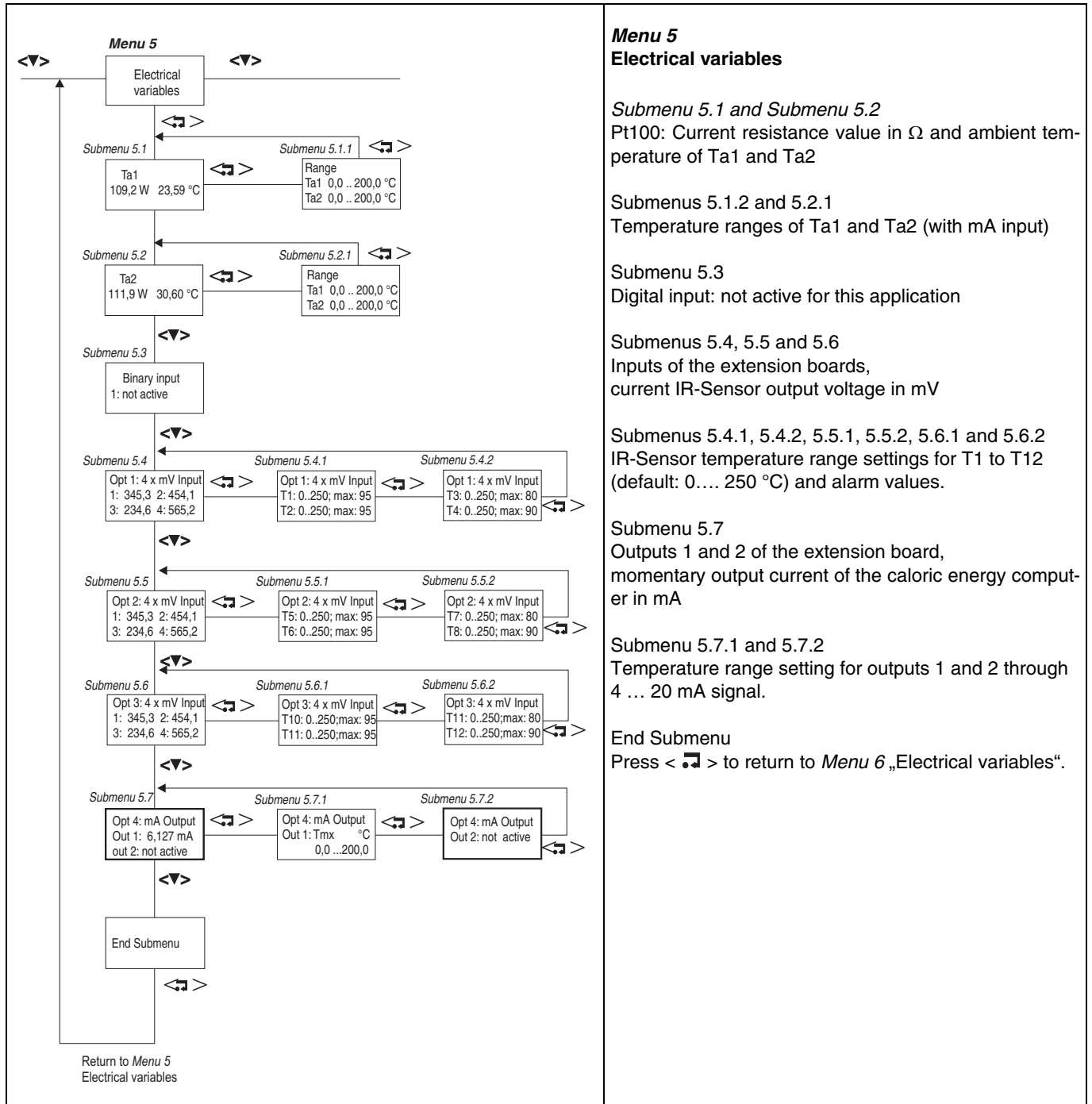

**Menu 5
Electrical variables**

Submenu 5.1 and Submenu 5.2
Pt100: Current resistance value in Ω and ambient temperature of Ta1 and Ta2

Submenus 5.1.2 and 5.2.1
Temperature ranges of Ta1 and Ta2 (with mA input)

Submenu 5.3
Digital input: not active for this application

Submenus 5.4, 5.5 and 5.6
Inputs of the extension boards, current IR-Sensor output voltage in mV

Submenus 5.4.1, 5.4.2, 5.5.1, 5.5.2, 5.6.1 and 5.6.2
IR-Sensor temperature range settings for T1 to T12 (default: 0... 250 °C) and alarm values.

Submenu 5.7
Outputs 1 and 2 of the extension board, momentary output current of the caloric energy computer in mA

Submenu 5.7.1 and 5.7.2
Temperature range setting for outputs 1 and 2 through 4 ... 20 mA signal.

End Submenu
Press < ↵ > to return to Menu 6 „Electrical variables“.

6.4.4 Error messages *Menu 6*

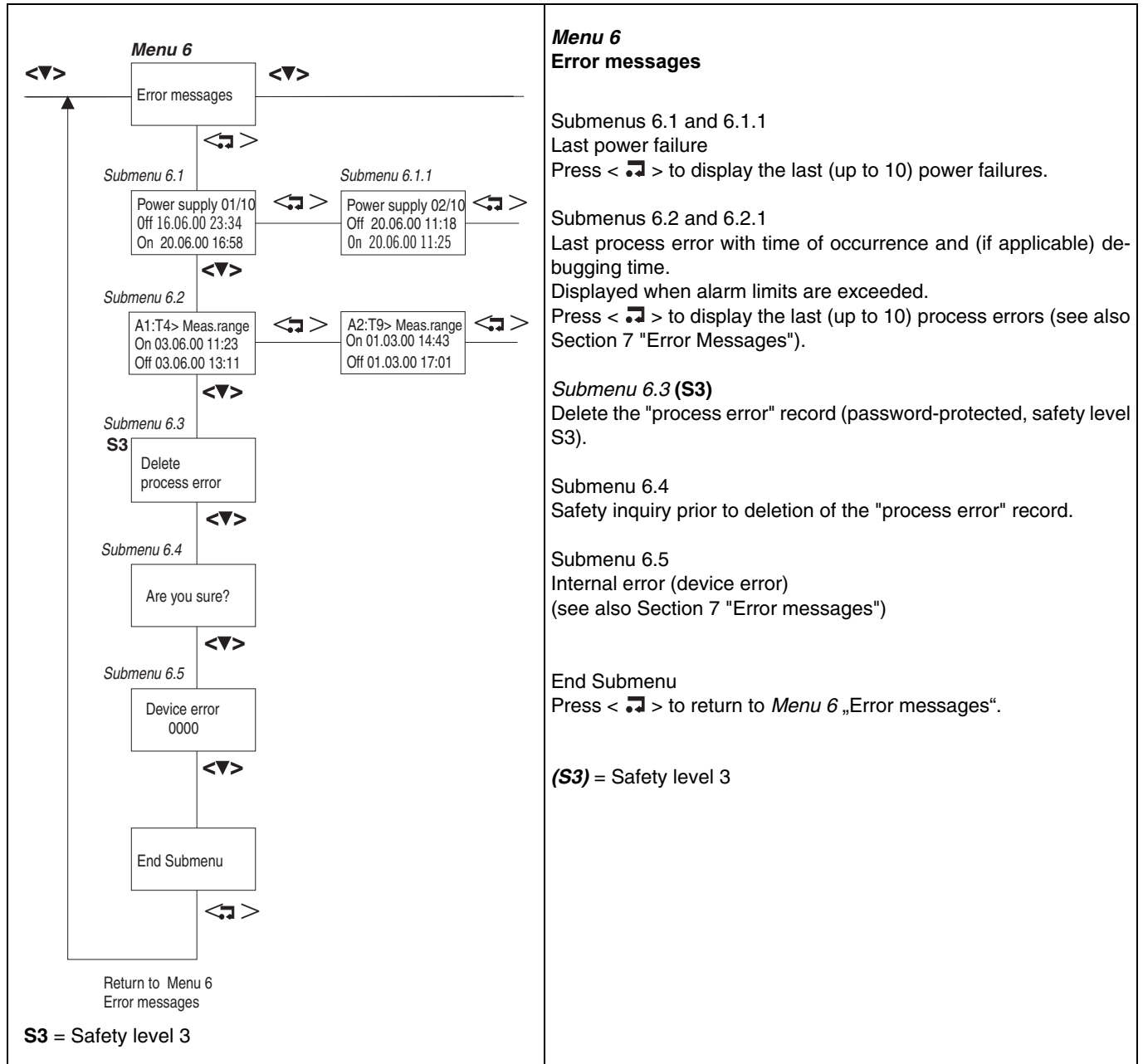

6.4.5 Date/time Menu 7

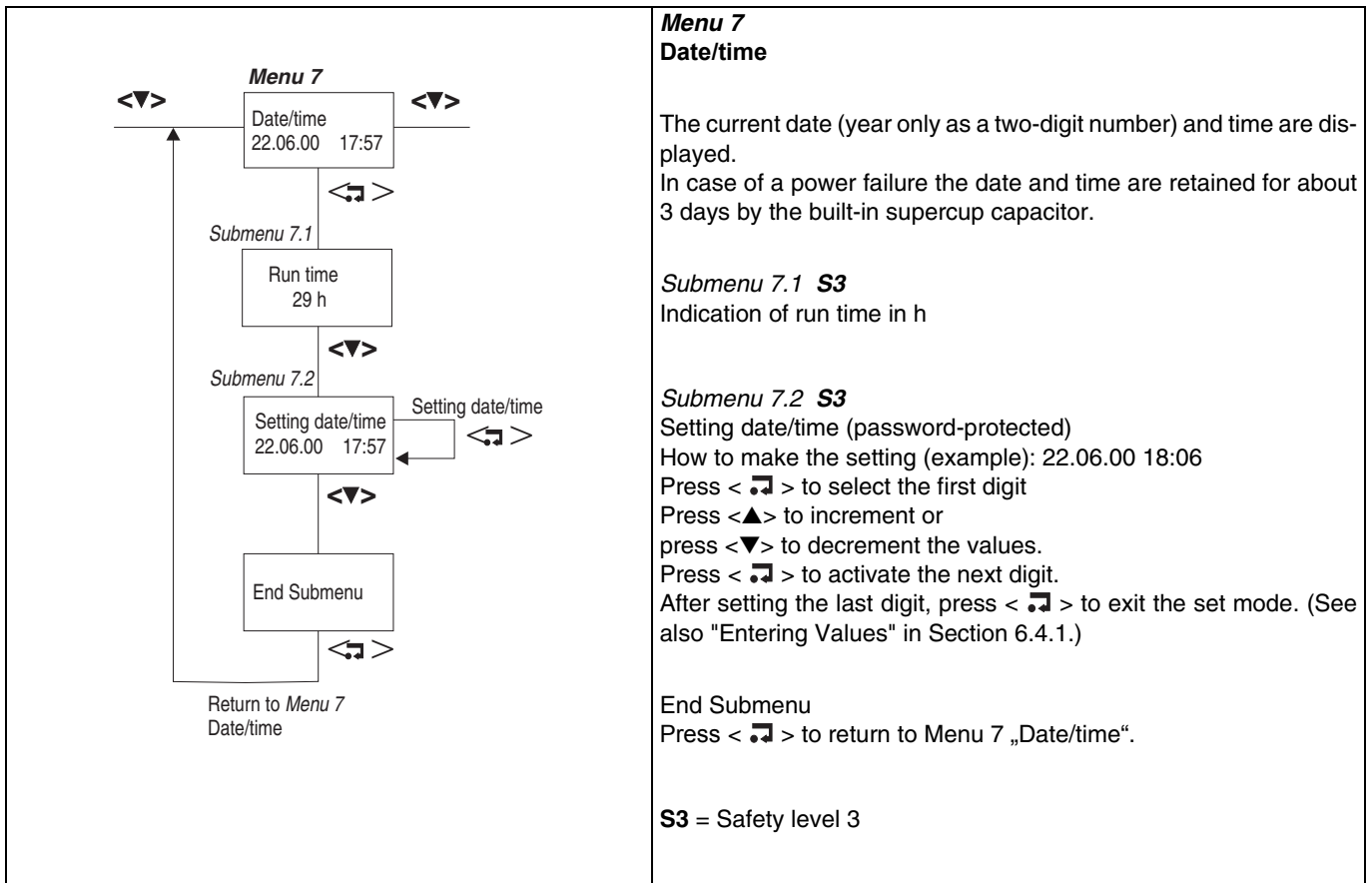

6.4.6 Service Menu 8

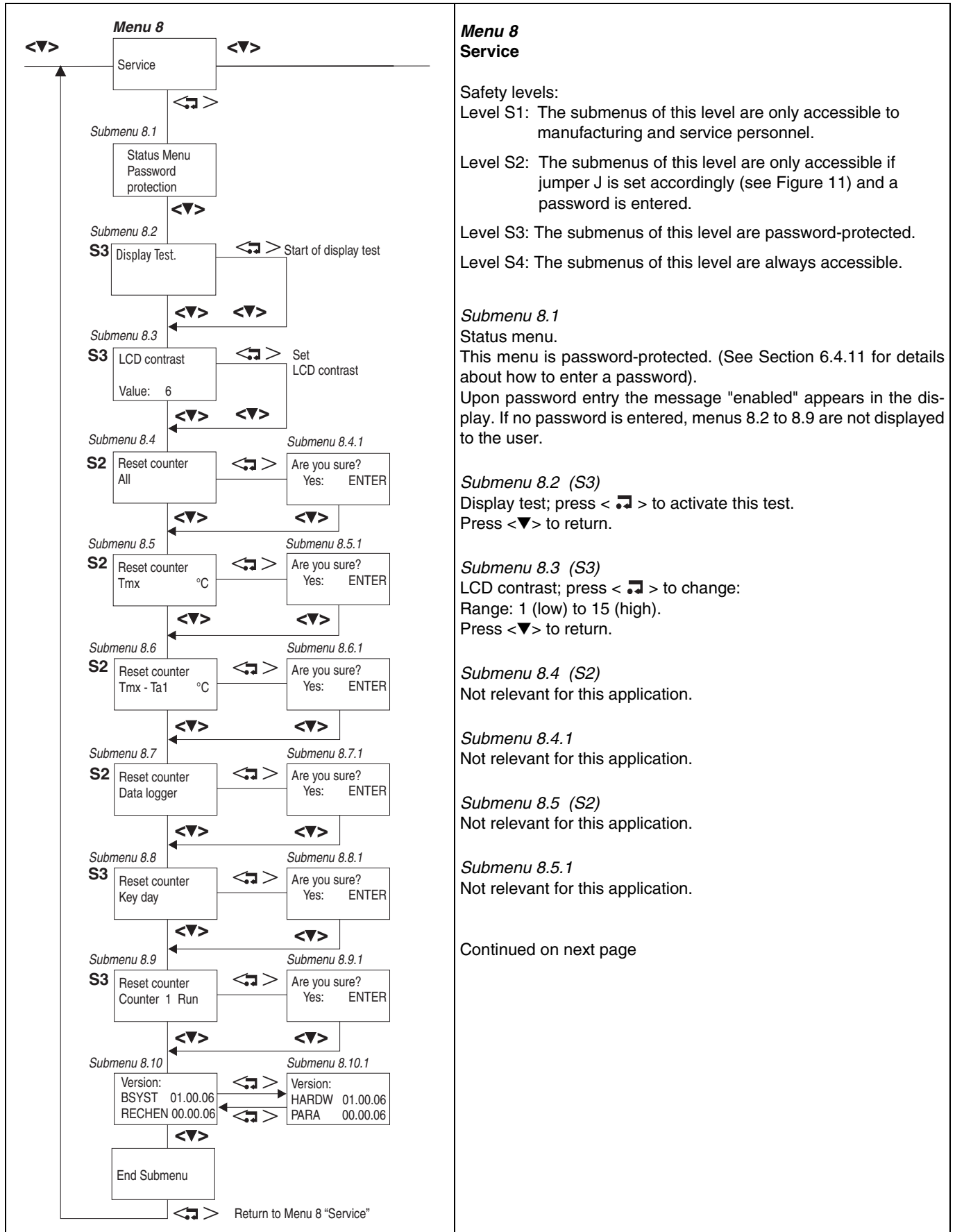

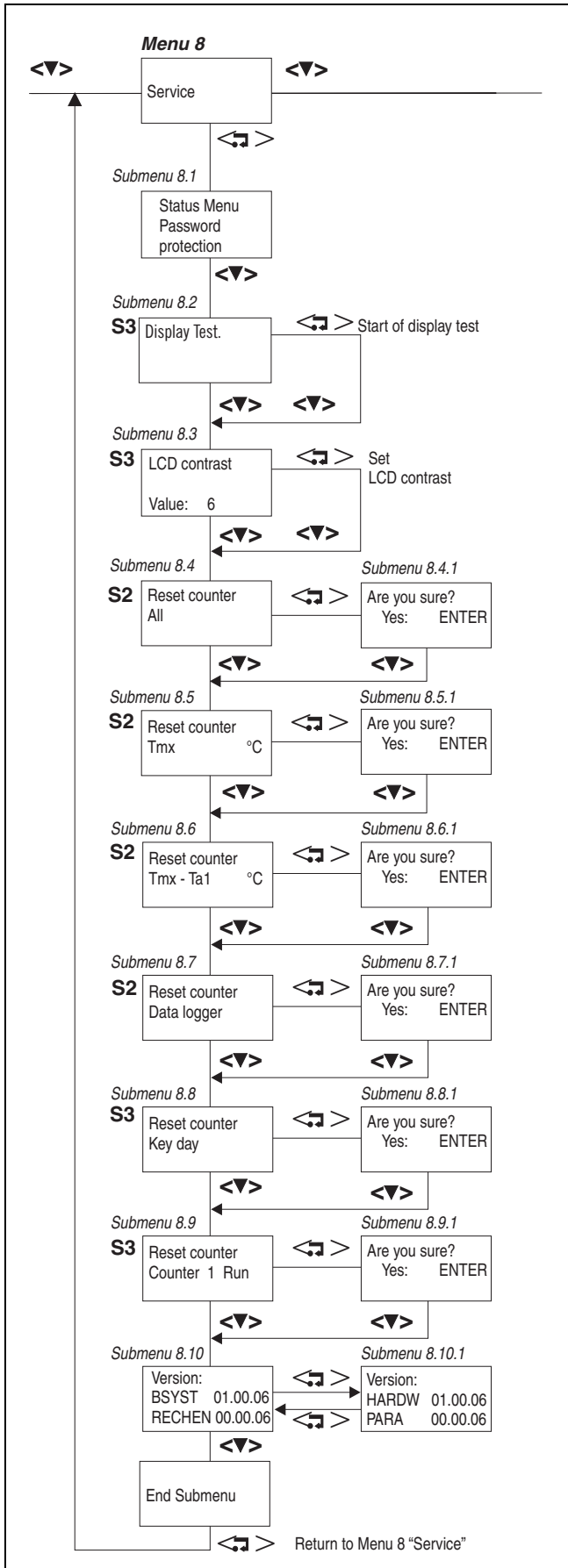

Continued from previous page

Submenu 8.6 (S2)
Not relevant for this application.

Submenu 8.6.1
Not relevant for this application.

Submenu 8.7 (S2)
Press < [key] > to delete the data logger.
Only possible with properly set jumper J (see Figure 11) and upon password entry (see description above)

Submenu 8.7.1
Safety inquiry for deletion of the data logger.
If yes, press ENTER key < [key] > ,
else continue with < [key] > .
S2 = Safety level 2 (see above)
S3 = Safety level 3 (see above)

Submenu 8.8 (S3)
Not relevant for this application.

Submenu 8.8.1
Not relevant for this application.

Submenu 8.9 (S3)
Not relevant for this application.

Submenu 8.9.1
Not relevant for this application.

Submenu 8.10
Indication of OS revision: BSYST 01.00.06
Indication of comp. program rev.: RECHEN00.00.01
Press < [key] > to display the hardware and software revision number.

Submenu 8.10.1
Indicate hardware revision No.: HARDW 01.00.00
Parameterization program: PARA 00.00.00

Press < [key] > to reach the
End submenu
Press < [key] > to return to Menu 8 "Service".

S2 = Safety level 2 (see above)
S3 = Safety level 3 (see above)

6.4.7 Data logger **Menu 9**

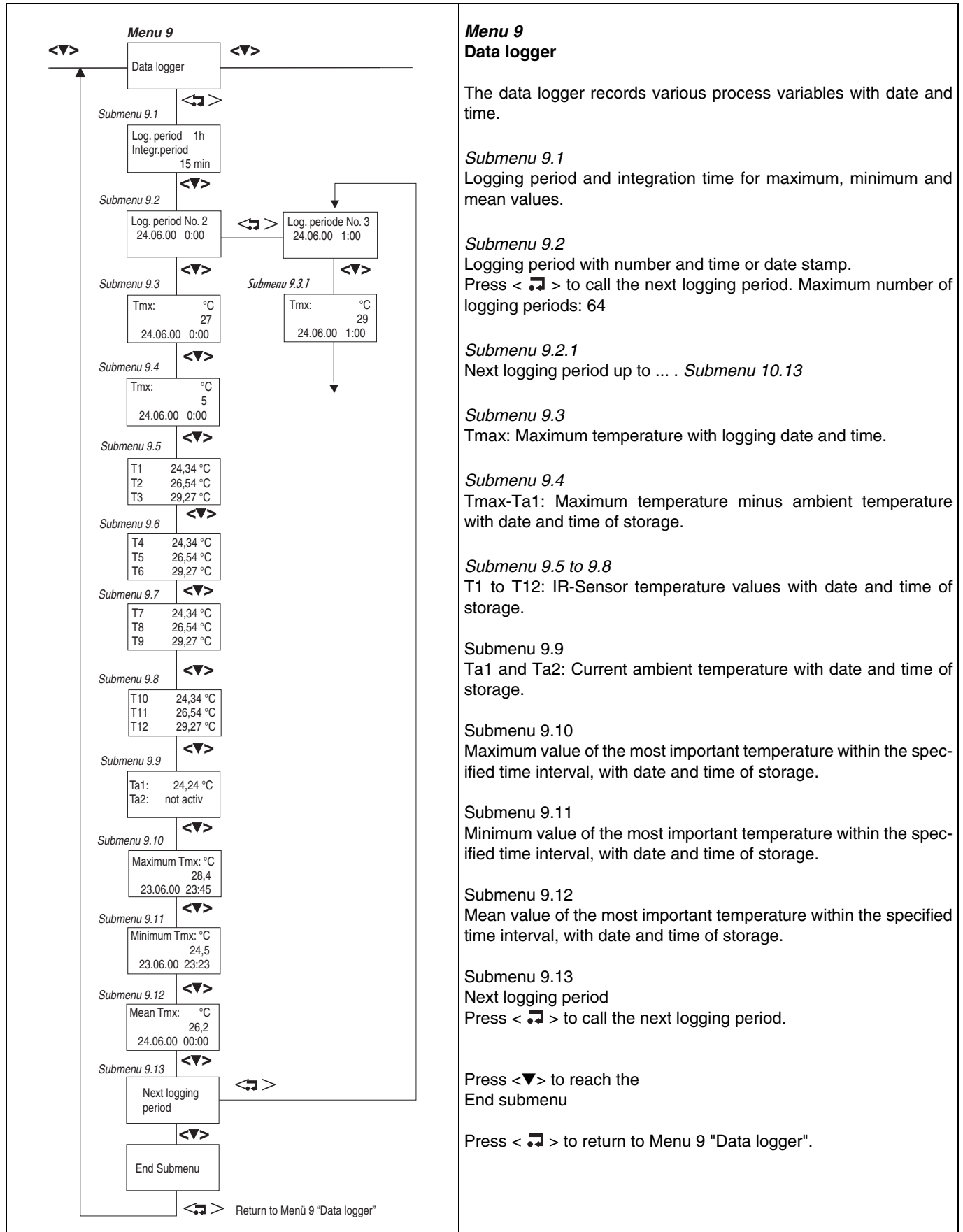

**Menu 9
Data logger**

The data logger records various process variables with date and time.

Submenu 9.1

Logging period and integration time for maximum, minimum and mean values.

Submenu 9.2

Logging period with number and time or date stamp. Press < ⏪ > to call the next logging period. Maximum number of logging periods: 64

Submenu 9.2.1

Next logging period up to *Submenu 10.13*

Submenu 9.3

Tmax: Maximum temperature with logging date and time.

Submenu 9.4

Tmax-Ta1: Maximum temperature minus ambient temperature with date and time of storage.

Submenu 9.5 to 9.8

T1 to T12: IR-Sensor temperature values with date and time of storage.

Submenu 9.9

Ta1 and Ta2: Current ambient temperature with date and time of storage.

Submenu 9.10

Maximum value of the most important temperature within the specified time interval, with date and time of storage.

Submenu 9.11

Minimum value of the most important temperature within the specified time interval, with date and time of storage.

Submenu 9.12

Mean value of the most important temperature within the specified time interval, with date and time of storage.

Submenu 9.13

Next logging period
Press < ⏪ > to call the next logging period.

Press < ⏩ > to reach the
End submenu

Press < ⏪ > to return to Menu 9 "Data logger".

6.4.8 Print function *Menu10*

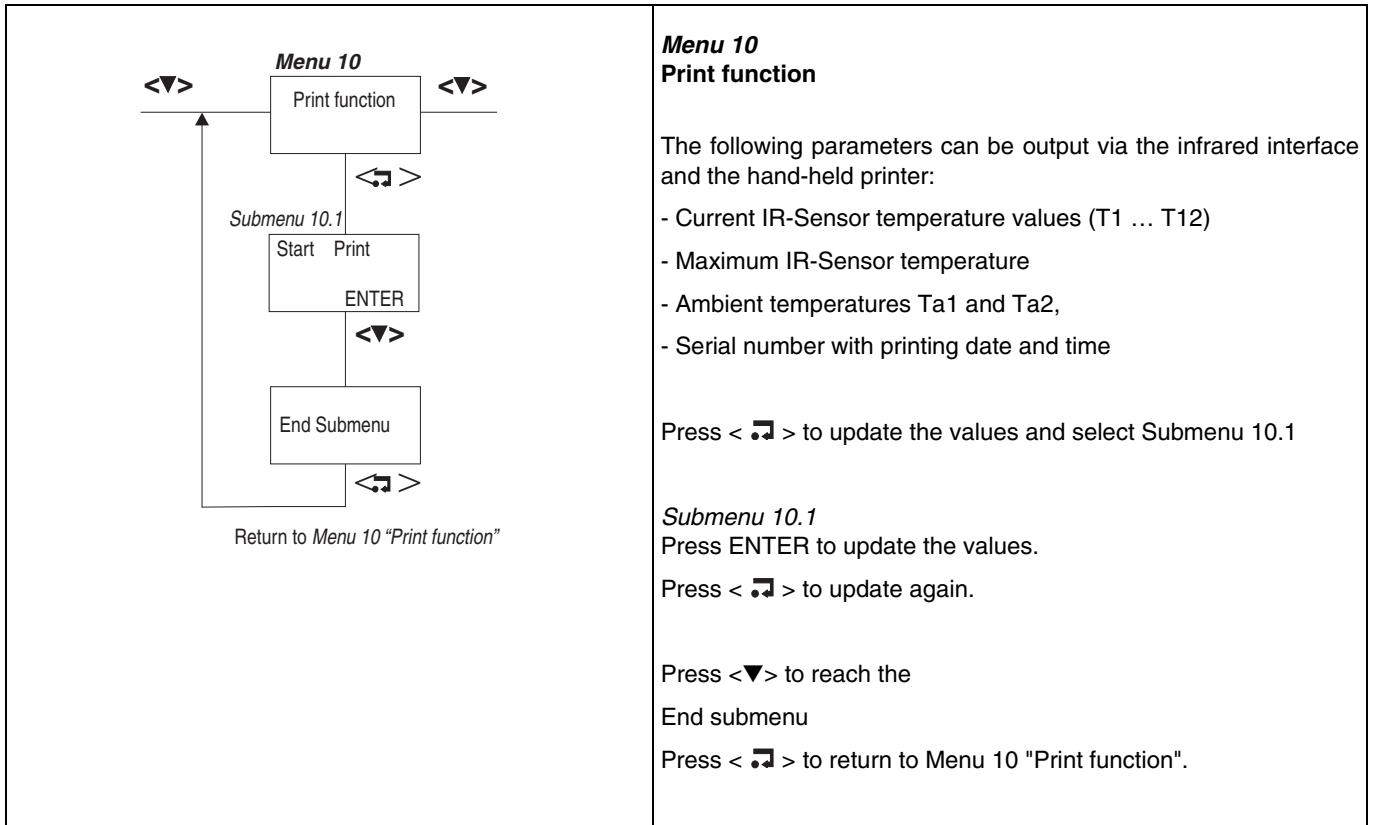

6.4.9 Tag name *Menu11*

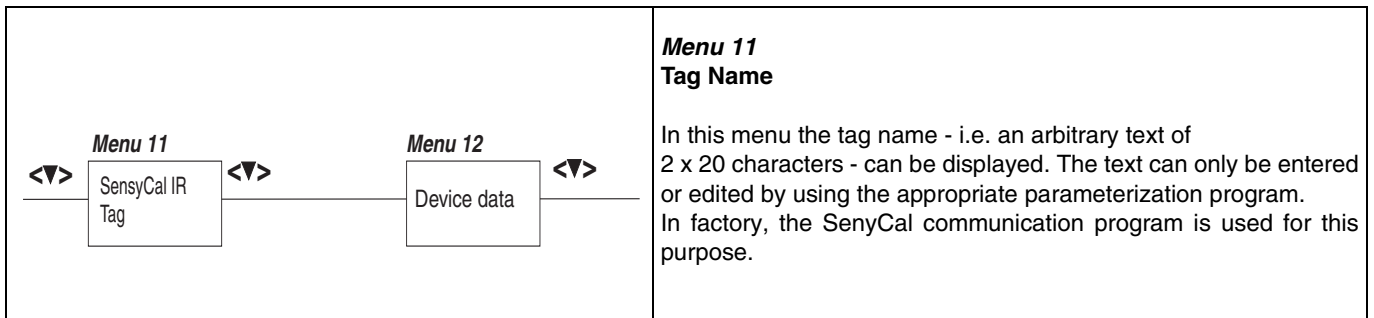

6.4.10 Device data **Menu 12**

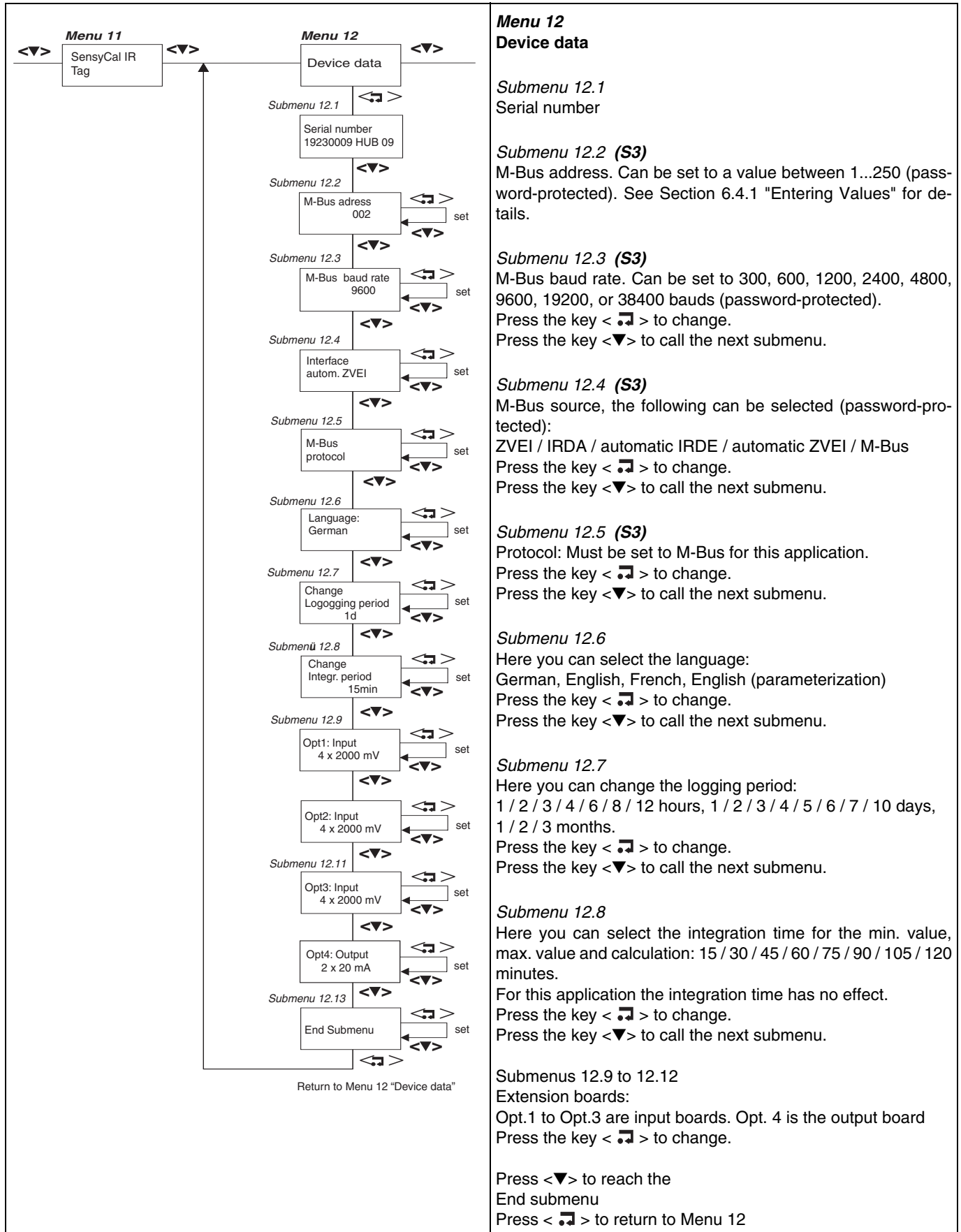

Menu 12

Device data

Submenu 12.1
Serial number

Submenu 12.2 (S3)

M-Bus address. Can be set to a value between 1...250 (password-protected). See Section 6.4.1 "Entering Values" for details.

Submenu 12.3 (S3)

M-Bus baud rate. Can be set to 300, 600, 1200, 2400, 4800, 9600, 19200, or 38400 bauds (password-protected). Press the key <↵> to change. Press the key <▼> to call the next submenu.

Submenu 12.4 (S3)

M-Bus source, the following can be selected (password-protected):
ZVEI / IRDA / automatic IRDE / automatic ZVEI / M-Bus
Press the key <↵> to change.
Press the key <▼> to call the next submenu.

Submenu 12.5 (S3)

Protocol: Must be set to M-Bus for this application.
Press the key <↵> to change.
Press the key <▼> to call the next submenu.

Submenu 12.6

Here you can select the language:
German, English, French, English (parameterization)
Press the key <↵> to change.
Press the key <▼> to call the next submenu.

Submenu 12.7

Here you can change the logging period:
1 / 2 / 3 / 4 / 6 / 8 / 12 hours, 1 / 2 / 3 / 4 / 5 / 6 / 7 / 10 days, 1 / 2 / 3 months.
Press the key <↵> to change.
Press the key <▼> to call the next submenu.

Submenu 12.8

Here you can select the integration time for the min. value, max. value and calculation: 15 / 30 / 45 / 60 / 75 / 90 / 105 / 120 minutes.
For this application the integration time has no effect.
Press the key <↵> to change.
Press the key <▼> to call the next submenu.

Submenus 12.9 to 12.12

Extension boards:
Opt.1 to Opt.3 are input boards. Opt. 4 is the output board
Press the key <↵> to change.

Press <▼> to reach the
End submenu
Press <↵> to return to Menu 12

6.4.11 Password *Menu 13*

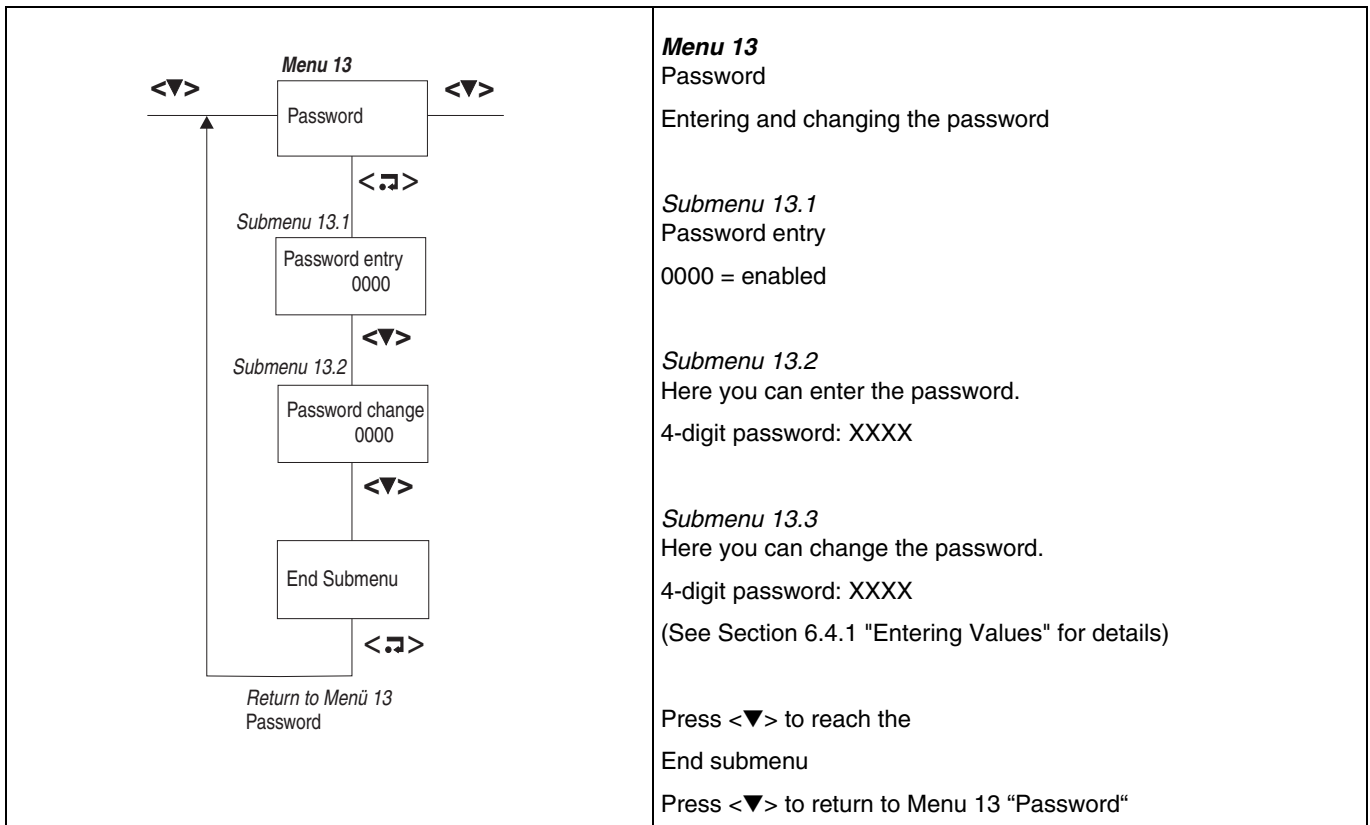

7 Error Messages

7.1 Process errors

Process errors that have a direct impact on the temperature measurement are indicated by the message "Error" flashing in the display. A plain text description of the error with date and time stamp can be called in the "Error messages" menu.

The following error messages exist:

Ta1 out of meas. range,	Ta2 out of meas. range,	T max > high limit,
T1 out of range,	T2 out of range,	T3 out of range,
T4 out of range,	T5 out of range,	T6 out of range,
T7 out of range,	T8 out of range,	T9 out of range,
T10 out of range,	T11 out of range,	T12 out of range

7.2 Device errors

Device error messages are binary-coded. They are indicated in the display as a 4-digit number.

0 0 0 0	No error
0 0 0 1	Parameter definition error, physical/electrical max. value < min. value
0 0 0 2	Parameter definition error, unit
0 0 0 4	Parameter definition error, display parameter
0 0 1 0	Flow sensor type error
0 0 2 0	Critical process error
0 1 0 0	Option card 1 error
0 2 0 0	Option card 2 error
0 4 0 0	Option card 3 error
0 8 0 0	Option card 4 error

If required, the individual error codes are added up, i.e if several errors occur at the same time, the codes are added up for every single digit.

Examples:

Display	0004	Error:	Parameter definition, display parameter
	0801		Option card 4 and parameter definition, physical/electrical max. value < min. value
	0534		Option cards 1 and 3 (1+4 added in the 3rd. digit), Flow sensor type error, critical process error and error of the display parameter definitions.

8 Retrofitting

8.1 General safety instructions



CAUTION

When opening covers or removing parts, energized parts may be exposed, except if this is possible without using a tool. Also, exposed connections may be live.

Prior to working on an open device always disconnect the device from all power sources. Operations on the open device in which personnel may come into contact with energized parts may only be performed by experts trained in the maintenance of electrical equipment and who are fully aware of the risks involved. Capacitors in the device may still be charged, even when the device is disconnected from all power sources. Do not use any other fuses than those of the specified type and rated current to replace defective fuses. Do not use "repaired" fuses. Do not shorten the fuse holder. If it must be assumed that safe operation is no longer ensured, the device must be put out of service immediately and must be secured against being accidentally put back to service.

It must be assumed that safe operation is no longer possible if the device

- as visible damages,
- does no longer work
- as been stored over a longer time under bad conditions
- as been exposed to bad transport conditions

8.2 Retrofitting option modules

<p>The diagram shows a green printed circuit board (PCB) with various electronic components. Labels include 'E' pointing to a capacitor, 'J' pointing to a component, 'RXD (red)' and 'TXD (green)' pointing to connection points, and '1', '2', '3', '4' pointing to slots at the bottom edge.</p>	<ol style="list-style-type: none"> 1. Dismount or disassemble the device (see section "Mounting", "Connecting" and "Commissioning"). 2. Remove the EMC protection housing (rear housing, if applicable) and the back panel. 3. Remove the main board. 4. Plug the option module onto the main board. RS 232/RS 485 card to Connector 4. alternative current output board to Connector 4 (depending on the application). 5. Prepare the appropriate cutout in the back panel. 6. Plug in the main board. 7. Mount the back panel and the rear housing (if applicable). 8. Mount and connect the device (see section "Mounting", "Connecting" and "Commissioning"). 9. The two signal lines of the RS 232/RS 485 card (option board 105) must be soldered to the RxD and TxD connection points (see Fig. 8-1) on the main board. 												
<p>Fig. 8-1 Main board</p> <table style="border: none;"> <tr> <td style="padding-right: 10px;">1 Slot 1</td> <td style="padding-right: 10px;">E</td> <td>Flash</td> </tr> <tr> <td>2 Slot 2</td> <td>J</td> <td>Jumper</td> </tr> <tr> <td>3 Slot 3</td> <td>RxD,</td> <td></td> </tr> <tr> <td>4 Slot 4</td> <td>TxD</td> <td>connections for RS 232/RS 485</td> </tr> </table>	1 Slot 1	E	Flash	2 Slot 2	J	Jumper	3 Slot 3	RxD,		4 Slot 4	TxD	connections for RS 232/RS 485	
1 Slot 1	E	Flash											
2 Slot 2	J	Jumper											
3 Slot 3	RxD,												
4 Slot 4	TxD	connections for RS 232/RS 485											

9 Maintenance

9.1 Safety instructions



CAUTION

When opening covers or removing parts, energized parts may be exposed, except if this is possible without using a tool. Also, exposed connections may be live.

Prior to working on an open device always disconnect the device from all power sources. Operations on the open device in which personnel may come into contact with energized parts may only be performed by experts trained in the maintenance of electrical equipment and who are fully aware of the risks involved. Capacitors in the device may still be charged, even when the device is disconnected from all power sources. Do not use any other fuses than those of the specified type and rated current to replace defective fuses. Do not use "repaired" fuses. Do not shorten the fuse holder. If it must be assumed that safe operation is no longer ensured, the device must be put out of service immediately and must be secured against being accidentally put back to service.

It must be assumed that safe operation is no longer possible if the device

- as visible damages,
- oes no longer work
- as been stored over a longer time under bad conditions
- as been exposed to bad transport conditions

9.2 Replacing fuse

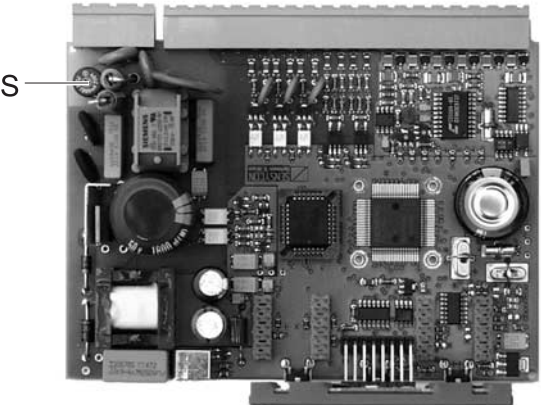
 <p>Fig. 9-1 Main board S Fuse</p>	<ol style="list-style-type: none"> 1. Dismount the device (see Sections "Mounting", "Connecting" and "Commissioning") 2. Remove the (rear part of the housing and the) back panel. 3. Remove the main board. 4. Replace fuse S: 24 V, 0.8 A 5. Plug in the main board. 6. Mount the back panel (and rear part of the housing) 7. Mount and connect the device (see Sections "Mounting", "Connecting" and "Commissioning").
---	---

10 Technical data

10.1 IR-Sensor CS

<p>General Specifications</p> <p>Environmental rating IP 65 (NEMA-4)</p> <p>Ambient temperature -20 ... +75 °C</p> <p>Storage temperature -40 ... +85 °C</p> <p>Relative humidity 10 ... 95 %, non condensing</p> <p>Material stainless steel</p> <p>Dimensions M12 x 1, 85 mm long</p> <p>Weight 58 g</p> <p>Cable length 10 m</p> <p>Cable diameter 4.3 mm</p> <p>Vibration IEC 68-2-6: 3G, 11 ... 200 Hz, any axis</p> <p>Shock IEC 68-2-27: 50G, 11 ms, any axis</p> <p>EMI 89/336/EWG</p> <p>Measurement Specifications</p> <p>Temperature range -20 ... +350 °C (scalable via software)</p> <p>Spectral range 8 ... 14 µm</p> <p>Optical resolution 10:1</p> <p>Accuracy¹⁾ ± 1.5 °C or 1.5 % of rate (whichever is greater)</p> <p>Repeatability¹⁾ ± 0.75 °C or ± 0.75 % of rate (whichever is greater)</p> <p>Temperature resolution²⁾ 0.1 °C (NETD)</p> <p>Response time 30 ms ... 2 s (95 % signal/adjustable via software)</p> <p>Warm-up time 10 min. (only at supply voltage ≥ 24 V)</p> <p>Emissivity/Gain 0.100 ... 1.100 (adjustable via 0 ... 5 V DC input or software)</p> <p>Transmissionsgrad 0.100 ... 1.000 (adjustable via software)</p> <p>Interface (optional) USB (programming interface)</p> <p>¹⁾ at ambient temperature 23 °C ± 5 °C ²⁾ NETD at object temperatures <100 °C and time constant > 0.2 s</p>	<p>Signal processing Average, Peak hold, Valley hold (adjustable via software)</p> <p>Software (optional) CSconfig and Thermal Oscilloscope</p> <p>Electrical Specifications</p> <p>Output [used pin] only alternatively selectable</p> <p>Analog [OUT] 0 ... 5 V¹⁾ or 0 ... 10 V²⁾, scalable</p> <p>Serial digital³⁾ [OUT + IN] uni- (burst mode) or bidirectional</p> <p>Alarm [OUT] output voltage adjustable, N/O or N/C</p> <p>Additional features LED alarm indication/LED aiming support</p> <p>Output impedances min. 10 kΩ load impedance</p> <p>Input programmable functional input on green IN pin for: – external emissivity adjustmentg [0 V ► ε = 0.1 5 V ► ε = 1.1] – ambient temperature compensation [0 V ► -20 °C 5 V ► 350 xC] – trigger (reset of hold functions) [5 V at IN-pin]</p> <p>Current draw 9 mA (12 ... 28 V DC)</p> <p>Power supply 5 ... 7 V DC or 12 ... 28 V DC</p> <p>¹⁾ 0 ... 4.6 V at supply voltage 5 V DC ²⁾ only at supply voltage ≥ 11 V ³⁾ inverted RS 232 signal, TTL, 9.6 kBaud</p> <p>CE-Conformity</p> <p>The product complies with the following standards: EMC: EN 61326-1 Safety regulations: EN 61010-1:1993/A2:1995 The product accomplishes the requirements of the EMC Directive 89/336/EEC and of the low-voltage Directive 73/23/EEC.</p> <p>Factory Default Settings</p> <p>The unit has the following presetting at time of delivery:</p> <table border="0"> <tr><td>Temperature range</td><td>0 ... 250 °C</td></tr> <tr><td>Output voltage</td><td>0 ... 2.5 V</td></tr> <tr><td>Emissivity</td><td>0.950</td></tr> <tr><td>Transmission</td><td>1,000</td></tr> <tr><td>Average time</td><td>0.2 s</td></tr> <tr><td>Amb. temperature source</td><td>Head temperature</td></tr> <tr><td>Limit value</td><td>95 °C</td></tr> <tr><td>Prealarm at</td><td>90 °C</td></tr> <tr><td>Alarm at</td><td>95 °C</td></tr> </table> <p>Maintenance</p> <p>Lens cleaning: Blow off loose particles using clean compressed air. The lens surface can be cleaned with a soft, humid tissue moistened with water or a water based glass cleaner.</p> <p>NOTICE: Never using cleaning compounds which contain solvents (neither for the lens not for the housing).</p>	Temperature range	0 ... 250 °C	Output voltage	0 ... 2.5 V	Emissivity	0.950	Transmission	1,000	Average time	0.2 s	Amb. temperature source	Head temperature	Limit value	95 °C	Prealarm at	90 °C	Alarm at	95 °C
Temperature range	0 ... 250 °C																		
Output voltage	0 ... 2.5 V																		
Emissivity	0.950																		
Transmission	1,000																		
Average time	0.2 s																		
Amb. temperature source	Head temperature																		
Limit value	95 °C																		
Prealarm at	90 °C																		
Alarm at	95 °C																		

10.2 Caloric energy computer

<p>Input</p> <p>12 × contact point temperature 12 IR-Sensors; mV input Measuring range 0 ... 250 °C (32 ... 452 °F)</p> <p>1 × ambient temperature 1 × Pt100 IEC for Ta1 Measuring range -100...250 °C, (-148...452 °F) Resolution 20 bit ≅ 0.0012 K</p> <p>Output</p> <p>3 digital outputs AB1, AB2 and Err Open collector, passive Electrically isolated via opto-couplers External supply to VDE 2188 category 2 Max. load 24 V (+2.5 %), <100 mA Max. insulation voltage 500 V (peak-peak) R_i when connected through <20 Ω</p> <p>AB1 Temperature alarm AB2 Temperature prealarm Err Error output</p> <p>Voltage inputs, output Influence of ambient temperature < 0.01 %/K Calibration error < 0.2 % of rate Max. linearity error < 0.005 % FSR Accuracy class of calculating unit EN 1434-1/OIML 75 Class 2</p> <p>2 analog outputs AX1 and AX2 (optional) Max. 2 active current outputs Current output Signal range 0/4...20 mA Max. load 500 Ω Open permissible, short-circuit-proof</p>	<p>Interfaces</p> <p>Communication via M-Bus Protocol according to EN 1434-3, IEC 870-5 and MODBUS protocol</p> <p>Optical interface on the front panel Operating mode configurable – Opto-head (ZVEI) standard IEC EN 61107 300 ... 9600 Baud</p> <p>Interface on the terminal strip 2-wire M-Bus interface 300 ... 38400 Baud RS 232/RS 485 300 ... 38400 Baud</p> <p>Configuration of device via configuration software (M-Bus). Reading of data (operating variables, data logger, etc.) via the M-Bus or MODBUS.</p> <p>Characteristic values</p> <p>IR-Sensor temperature inputs ≅ 16 bit</p> <p>Ambient temperature inputs</p> <p>Temperature deviation 0.3 % of upper range value or 0.1 °C (whichever is greater)</p> <p>Operating conditions</p> <p>Environmental specifications</p> <p>Ambient temperature -5 ... +55 °C (23 ... 131 °F)</p> <p>Storage temperature -25 ... +70 °C (-13 ... 158°F)</p> <p>Climate class Ambient temperature class C to EN 1434-1</p> <p>Relative humidity Tested according to EN 1434-4, IEC 62-2-30</p> <p>Condensing Permissible</p> <p>Protection IP 40</p> <p>Shock resistance, operation, at 20 °C (68 °F) Vibration test to IEC 68-2-6, sine, 10...150 Hz, 1 octave/min, 2g, 13 h on each axis Shock test to IEC 68-2-27, half-sine, 30g, 11 ms, 3 shocks per axis</p> <p>Electromagnetic compatibility (EMC)</p> <p>EMI/RFI shielding to EN 50082-2 (EN 6100-4-2, -3, -4, -5, -6) additionally to EN 1434-4 (Class C) RFI suppression to EN 50081-2 (EN 55 011 Class A)</p>
--	---

<p>Design features</p> <p>Type/Dimensions</p> <p>Panel-mounting</p> <p>Basic unit</p> <p>Dimensions 144 mm x 72 mm x 117 mm</p> <p>Weight around 0.5 kg</p> <p>Material polycarbonate</p> <p>Panel cutout 139 mm x 69 mm</p> <p>EMC protection housing</p> <p>Dimensions 180 mm x 72 mm x 145 mm</p> <p>Display and GUI</p> <p>Display</p> <p>Graphics display, 120 x 32 pixels</p> <p>Data logger</p> <p>Data logger</p> <p>Storage of 16 operating variables over 64 periods: 12 IR-Sensor values and maximum temperature value</p>	<p>Power supply, whole system</p> <p>Direct voltage</p> <p>24 V DC \pm 5 %</p> <p>Power consumption</p> <p>24 V 1...10 VA depending on extensions</p> <p>Error reporting and error output</p> <p>Detection of internal errors through regular self-diagnostics</p> <p>Display</p> <p>Critical device errors, e.g. memory failure</p> <p>Process errors, with time and date</p> <p>Last 10 power failures</p> <p>Storage of up to 10 operating errors</p> <p>Plain text display with time stamp</p> <p>Error output</p> <p>Open collector, passive (see output), Display</p>
--	--

11 Configuration and communication program

The standard PC configuration software FCOM200 for the measurement computers used for configuring the standard applications can be installed and run on all usual commercial PCs.

The "ParaTool" Software is used for:

- configuring the device
- reading current process data in online mode
- setting date, time, baud rate, address

The link between the PC/laptop and the measurement computer can be established in two different ways (see Fig. 11-1):

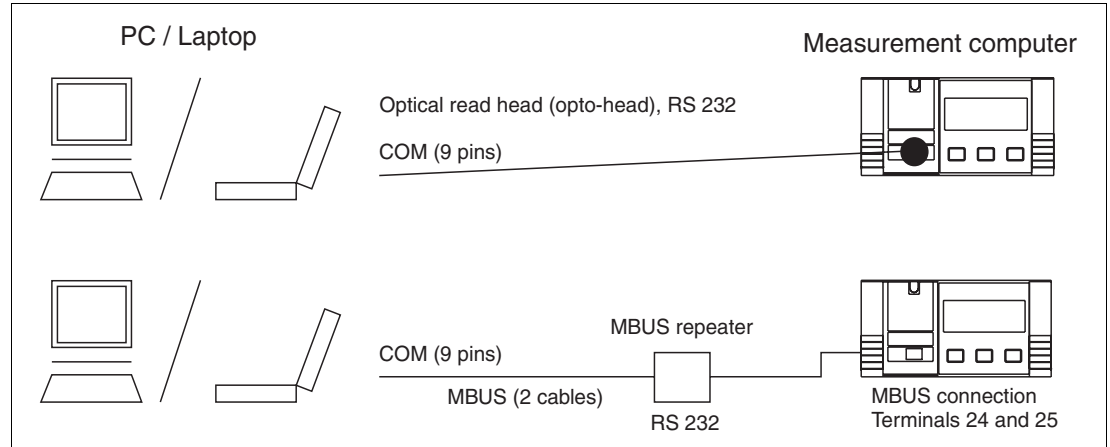

Fig. 11-1 Possible links between a PC/laptop and the measurement computer
 TopOptical read head (opto-head), RS 232
 BottomM-Bus repeater, RS 232

Useful hint for communication

The following PC and device settings must fully match to enable proper communication:

- Bus address
- Baud rate
- Interface
- Interface: with opto-head opto-head/automatically
- with M-Bus repeater M-Bus repeater

Infrared printer

Measurement computer data can be printed on the portable infrared printer type "HP82240B Infrared Printer" that connects to the infrared interface. The printer can be ordered under catalog number 7962882 (see price list 70/18.2 EN).

12 Putting out of service and packaging

Packaging for transport or return to the manufacturer

If the original packaging material is no longer available, wrap the device in a padded plastic film or corrugated paper board and place it in a box of sufficient size lined with a shock-absorbing material (e.g. cellular material). The thickness of this material should be in accordance with the device weight and the type of shipment. Attach a "handle with care" sticker to the box.

For overseas shipping add a desiccant bag (e.g. with silica gel) to the device and then weld it in a 0.2 mm polyethylene foil. The required amount of desiccant depends on the packing volume and the approximate transportation time (assume at least 3 months). Additionally line the box with a layer of union paper.

ABB has Sales & Customer Support expertise in over 100 countries worldwide.

www.abb.com/flow

The Company's policy is one of continuous product improvement and the right is reserved to modify the information contained herein without notice.

Printed in the Fed. Rep. of Germany (12.2009)

© ABB 2009



ABB Ltd.

Oldends Lane, Stonehouse
Gloucestershire, GL10 3TA
UK

Tel: +44(0)1453 826661
Fax: +44(0)1453 829671

ABB Inc.

125 E. County Line Road
Warminster, PA 18974
USA

Tel: +1 215 674 6000
Fax: +1 215 674 7183

ABB Automation Products GmbH

Borsigstr. 2
63755 Alzenau
Germany

Tel: +49 551 905-534
Fax: +49 551 905-555
CCC-support.deapr@de.abb.com