

EN
English

Commissioning Instruction
Rail Mounted Temperature Transmitter
TTR200



HART 
COMMUNICATION PROTOCOL

ABB

Rail Mounted Temperature Transmitter TTR200

Commissioning Instruction - EN

CI/TTR200-EN

08.2008

Rev. A

Manufacturer:

ABB Automation Products GmbH

Borsigstraße 2

63755 Alzenau

Germany

Tel.: +49 551 905-534

Fax: +49 551 905-555

CCC-support.deapr@de.abb.com

© Copyright 2008 by ABB Automation Products GmbH
Subject to change without notice

This document is protected by copyright. It assists the user with the safe and efficient operation of the device. The contents may not be copied or reproduced in whole or in excerpts without prior approval of the copyright holder.

1	Safety	3
1.1	General Safety Information	3
1.2	Intended use	3
1.3	Technical limit values	3
1.4	Warranty provision	4
1.5	Symbols and warnings	4
1.6	Operator liability	5
1.7	Personnel qualification	5
1.8	Electrical installation safety information	5
1.9	Operating safety information	5
2	Use in areas requiring ignition protection	6
2.1	Approvals	6
2.2	Level of protection	6
2.3	Electrostatic charging	6
2.4	Grounding	6
2.5	Interconnection	6
2.6	Configuration	6
2.7	Explosion-protection relevant information	6
3	Installation	7
4	Electrical connection	7
4.1	Conductor material	8
4.2	Pin configuration	8
4.2.1	Supply voltage / sensor connection	8
4.3	Standard application	9
4.4	Electrical interconnection in explosion risk area	11
4.4.1	Installation in ignition protection areas	12
4.4.2	Zone 0	12
4.4.3	Zone 1 (0)	13
4.4.4	Zone 1 (20)	14
4.4.5	Zone 2	15
5	Startup Operation	15
6	Appendix	16
6.1	Additional documents	16
6.2	Permits and certifications	16

1 Safety

1.1 General Safety Information

The “Safety” chapter provides an overview of the safety aspects to be observed for the operation of the device.

The device is built based on state-of-the-art technology and is operationally safe. It was tested and left the factory in a proper state. The requirements in the manual as well as the documentation and certificates must be observed and followed in order to maintain this state for the period of operation.

The general safety requirements must be complied with completely during operation of the device. In addition to the general information, the individual chapters of the manual contain descriptions about processes or procedural instructions with specific safety information.

Only the observance of all safety information enables the optimal protection of personnel as well as the environment from hazards and the safe and trouble-free operation of the device.

1.2 Intended use

This device is intended for the following uses:

- To measure the temperature of fluid, pulpy or pasty substances and gases or resistance/voltage values.

The following items are included in the intended use:

- Read and follow the instructions in this manual.
- Observe the technical ratings (refer to the section “Technical data” or data sheet).

Repairs, alterations and enhancements or the installation of replacement parts is only permissible as far as described in the manual. Further actions must be verified with ABB Automation Products GmbH. Excluded from this are repairs performed by ABB-authorized specialist shops.

1.3 Technical limit values

The device is designed for use exclusively within the stated values on the name plate and in the technical specifications (see data sheets). These must be complied with accordingly, e.g.:

- The maximum operating temperature may not be exceeded.
- The permitted operating temperature may not be exceeded.
- The housing protection system must be observed.

1.4 Warranty provision

A use contrary to the device's stipulated use, disregarding of this manual, the use of under-qualified personnel as well as unauthorized alterations excludes the manufacturer of liability from any resulting damages. The manufacturer's warranty expires.

1.5 Symbols and warnings



Danger – <Serious damage to health / risk to life>

One of these symbols in conjunction with the “Danger” warning indicates an imminent danger. If it is not avoided, death or serious injury will result.



Warning – <Bodily injury>

The symbol in conjunction with the “Warning” message indicates a possibly dangerous situation. If it is not avoided, death or serious injury could result.



Caution – <Slight injuries>

The symbol in conjunction with the “Caution” message indicates a possibly dangerous situation. If it is not avoided, slight or minor injury can result. May also be used for property damage warnings.



Notice – <Property damage>!

The symbol indicates a possibly damaging situation. If it is not avoided, the product or something in its area can be damaged.



Important

The symbol indicates operator tips or especially useful information. This is not a message for a dangerous or damaging situation.

1.6 Operator liability

Before the use of corrosive and abrasive measuring medium, the operator must clarify the resistance of all parts that come into contact with the medium to be measured. ABB will gladly support you with the selection, however, cannot accept any liability.

The operators must strictly observe the applicable national regulations in their countries with regards to installation, function tests, repairs, and maintenance of electrical devices.

1.7 Personnel qualification

The installation, commissioning and maintenance of the device may only be carried out through trained specialist personell authorized by the plant operator. The specialist personnel must have read and understood the manual and comply with its instructions.

1.8 Electrical installation safety information

The electrical connection may only be performed by authorized specialist personnel according to the electrical plans.

Comply with electrical connection information in the manual. Otherwise, the electrical protection class can be affected.

The secure separation of contact-dangerous electrical circuits is only guaranteed when the connected devices fulfill the requirements of the DIN EN 61140 (VDE 0140 Part 1) (basic requirements for secure separation).

For secure separation, run the supply lines separated from contact-dangerous electrical circuits or additionally insulate them.

1.9 Operating safety information

Before switching on, ensure that the specified environmental conditions in the “Technical Specifications” chapter and in the data sheet are complied with and that the power supply voltage corresponds with the voltage of the transmitter.

When there is a chance that safe operation is no longer possible, put the device out of operation and secure against unintended operation.

2 Use in areas requiring ignition protection

Special regulations must be observed in explosion-protection zones for the auxiliary power connection, signal inputs/outputs and ground connection. Information on ignition protection in the separate chapters must be observed.



Notice - Potential damage to parts!

All parts must be installed in accordance with manufacturer information and relevant standards and regulations.

Startup and operation must comply with EN 60079-14 (Installation of equipment in potentially explosive atmospheres).

2.1 Approvals

The approvals for use of the TTR200 temperature transmitter in explosion-protection areas can be found in the section "Explosion-protection relevant information" in the operating instructions.

2.2 Level of protection

The adapters for the model TTR200 temperature transmitter meet the IP 20 level of protection in accordance with IEC 60529:1989.

2.3 Electrostatic charging

When using the transmitter in zone 0, make sure you prevent electrostatic charging of the TTR200-E1H temperature transmitter (observe warnings on equipment).

2.4 Grounding

If for functional reasons, the intrinsically safe circuit has to be grounded by connection to the equipotential bonding system, it may only be grounded at a single location.

2.5 Interconnection

If transmitters are operated in an intrinsically safe circuit, proof that the interconnection is intrinsically safe must be provided in accordance with DIN VDE 0165/Part1 (EN 60079-25/2004 and IEC 60079-25/2003). In general, intrinsically safe circuits require proof of interconnection.

2.6 Configuration

The TTR200-E1 temperature transmitters can be installed in the explosion-protection area in compliance with the proof of interconnection and directly in the explosion-protection area using approved handheld HART terminals as well as by coupling an ignition-proof modem to the circuit outside the explosion-protection area.

2.7 Explosion-protection relevant information

For additional information, refer to the section "Explosion-protection relevant information" or the data sheet.

3 Installation

The transmitter is mounted apart from the sensor on a 35 mm rail acc. to EN 60175.

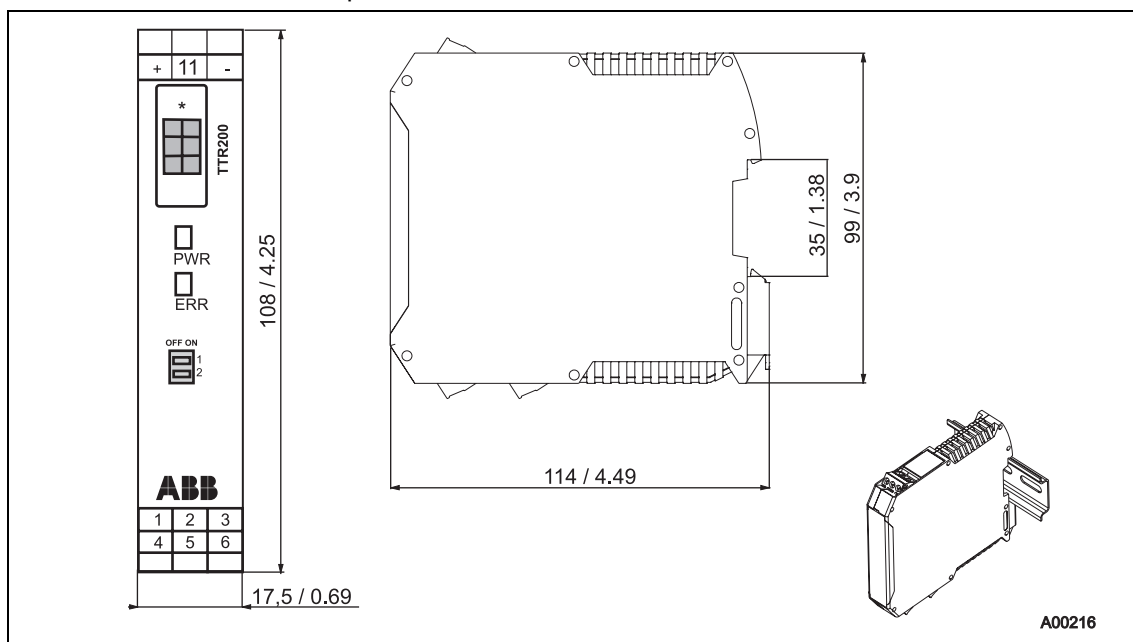

Fig. 1

4 Electrical connection



Warning – Electrical voltage risk!

Observe the corresponding instructions for the electrical installation. Only connect in dead-voltage state!

Since the transmitter has no switch-off elements, overvoltage protection devices, lightning protection or voltage separation capacity must be provided on the plant side.

Energy supply and signal are routed in the same line and are to be implemented as SELV or PELV circuit according to norm (standard version). In the ignition-proof version, the guidelines according to the ignition-proof norms are to be adhered to.

It must be checked whether the existing power supply corresponds with the specifications on the model plate and in the technical specifications in the “Technical specifications” section or the data sheet.



Important

The signal cable wires must be provided with wire end sleeves.

The slotted screws of the connection terminals are tightened with a size 1 screwdriver (3.5 mm).

Electrical connection

4.1 Conductor material

- Standard conductor material must be used for the power supply cable.
- The maximum connectable conductor cross-section amounts to 2.5 mm².



Notice - Potential damage to parts!

A rigid conductor material can result in wire breaks.

The connecting cable must be flexible.

4.2 Pin configuration

4.2.1 Supply voltage / sensor connection

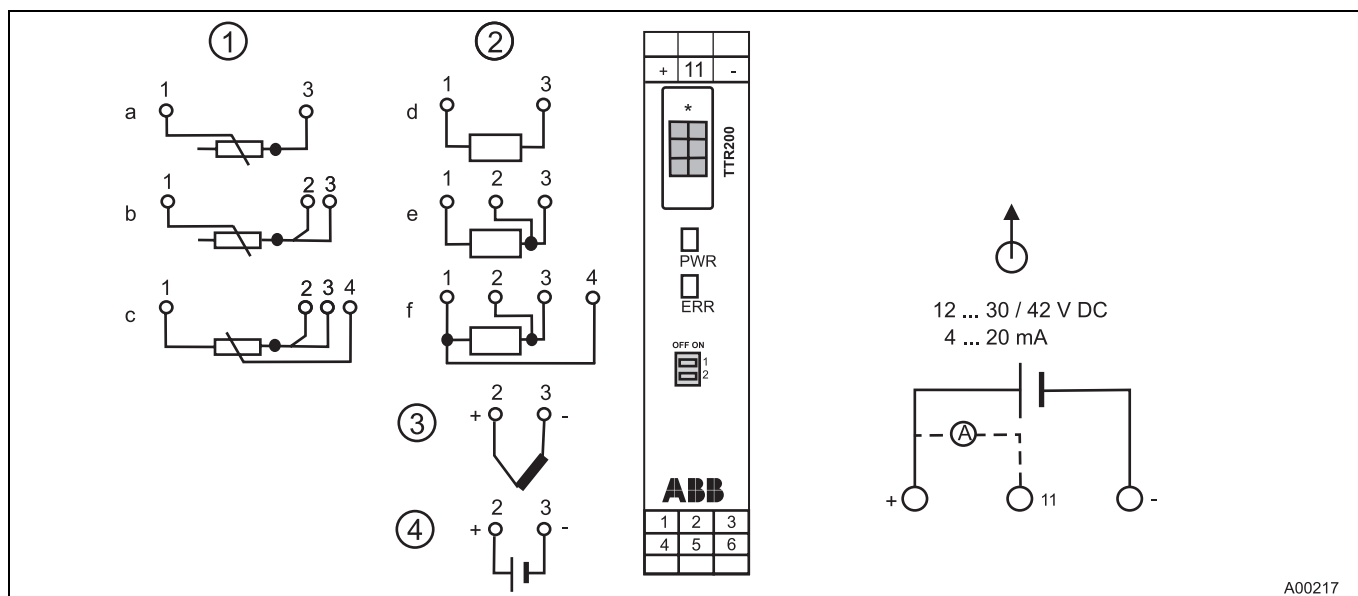

Fig. 2: *(planned local configuration interface/inoperable)

1 Potentiometer: 0 ... 500 Ω or 0 ... 5000 Ω

- a Potentiometer, 2-wire circuit
- b Potentiometer, 3-wire circuit
- c Potentiometer, 4-wire circuit

2 RTD resistance sensors (e.g., Pt100)

- d RTD, 2-wire circuit
- e RTD, 3-wire circuit
- f RTD, 4-wire circuit

3 Thermocouple

Depending on the sensor model, a variety of line materials can be used for sensor connections. The integrated reference point makes it possible to directly connect thermal compensating lines.

4 Voltage measurement

Note

Terminal 11: Measurement of 4 ... 20 mA output current without opening / interrupting the current loop.

- PWR / green LED: Supply voltage display
- ERR / red LED: sensor, sensor lead & unit fault signaling
- DIP switch 1: on -> Hardware write protection is enabled
- DIP switch 2: no function

4.3 Standard application

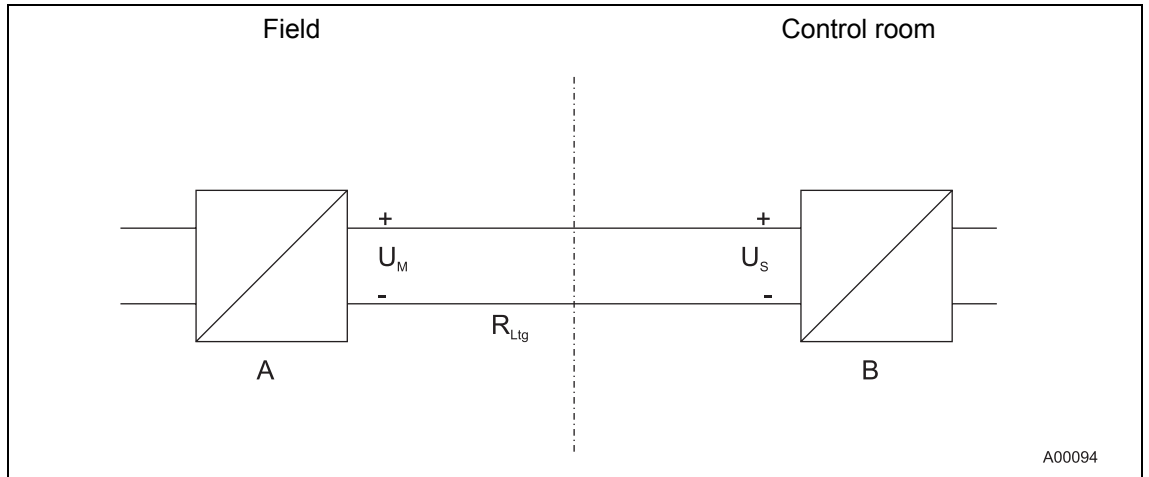

Fig. 3

A Transmitter

B Power supply / SPS input with supply

When connecting transmitters and power supplies, observe the following specification:

$$U_{Mmin} \leq U_{Smin} + 0.02A \times R_{Ltg}$$

Where

U_{Mmin} : Minimum operating voltage of transmitter (refer to technical data for transmitter)

U_{Smin} : Minimum supply voltage of repeater power supply / SPS input

R_{Ltg} : Line resistance between transmitter and power supply

For HART functionality, use power supplies or SPS input cards with HART mark. If this is not possible, the interconnection must have a resistance $\geq 250 \Omega$ ($< 1100 \Omega$).

The signal line can be connected with or without ground. When connecting the ground (minus side), make sure that only one side of the contact is connected to the equipotential bonding system.

Standard application with HART functionality

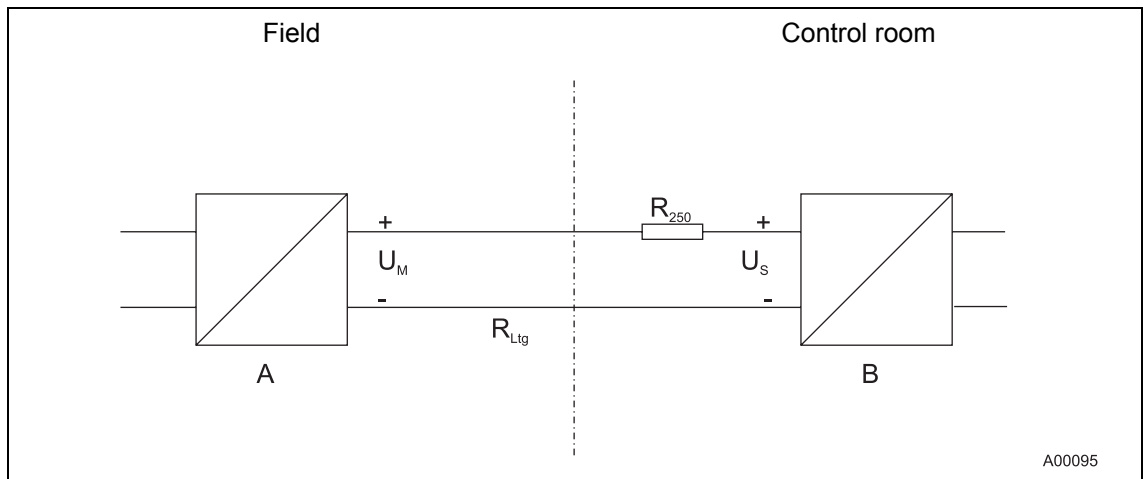

Fig. 4

A Transmitter

B Power supply / SPS input with supply

Adding resistance R_{250} increases the minimum supply voltage:

$$U_{Mmin} \leq U_{Smin} + 0.02A \times (R_{Ltg} + R_{250})$$

Where

U_{Mmin} : Minimum operating voltage of transmitter (refer to technical data for transmitter)

U_{Smin} : Minimum supply voltage of repeater power supply / SPS input

R_{Ltg} : Line resistance between transmitter and power supply

R_{250} : Resistance for HART functionality

4.4 Electrical interconnection in explosion risk area

Special interconnections are required for use in hazardous areas depending on the safety requirements.

Intrinsic safety

The Power supply SPS inputs must have corresponding input protection circuits available in order to eliminate a hazard (spark formation). An interconnection inspection must be performed. For proof of the intrinsic safety, the electrical limit values are to be used as the basis for the prototype test certificates of the apparatuses (devices), including capacitance and inductivity values of the wires. The proof of the intrinsic safety is given if the following conditions are fulfilled with comparison of the limit values of the apparatus.

Transmitter (intrinsically safe apparatus)		Power supply / SPS input (related apparatus)
U_i	\geq	U_o
I_i	\geq	I_o
P_i	\geq	P_o
$L_i + L_c$ (cable)	\leq	L_o
$C_i + C_c$ (cable)	\leq	C_o

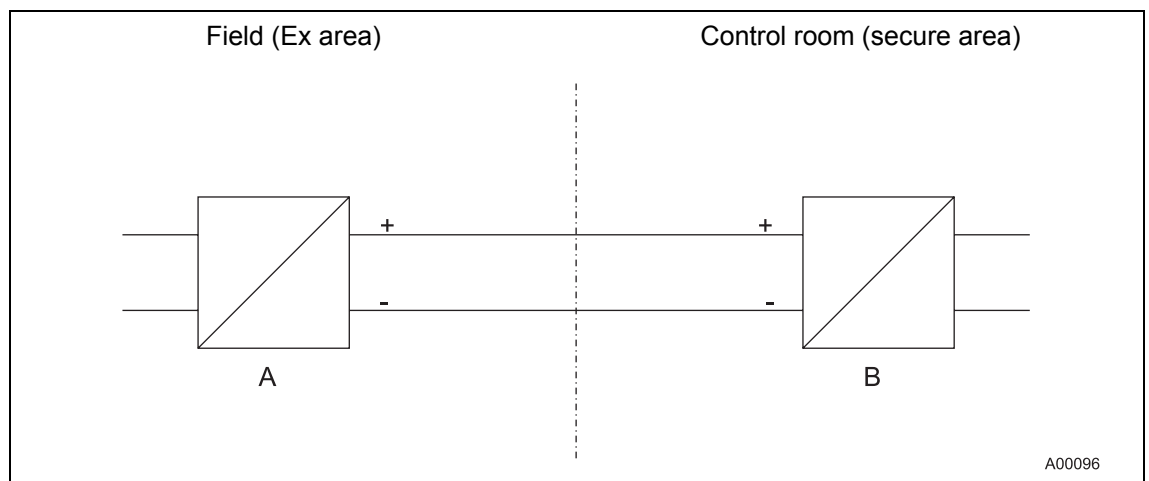

Fig. 5

A Transmitter

B Power supply SPS input



Important

Observe the “Technical specifications” and “Explosion-protection technical data” chapters (see data sheet and/or operating instructions).

4.4.1 Installation in ignition protection areas

Transmitters can be installed in a wide variety of industrial sectors. Systems that requires ignition protection are divided into zones. As a result, different instruments are also required. For additional information, refer to the section “Explosion-protection relevant information” or the data sheet.

4.4.2 Zone 0

Transmitter design: II 1G EEx ia IIC T6

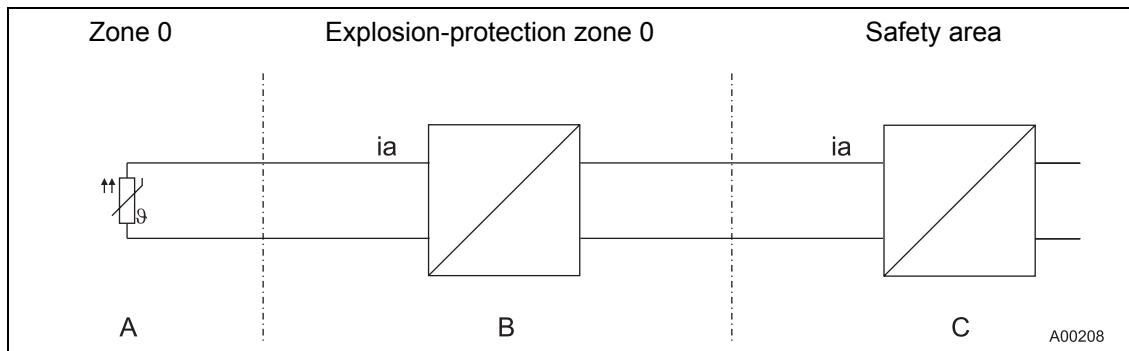

Fig. 6

- A Sensor
- B Transmitter in housing with IP 20 level of protection
- C Power supply [EEx ia]

For instruments in zone 0, the input for the repeater must be in [EEx ia] design.

When using the transmitter in zone 0, make sure you prevent electrostatic charging of the temperature transmitter (observe warnings on equipment).

The sensor must be used by the user in accordance with applicable ignition-protection standards.

4.4.3 Zone 1 (0)

Transmitter design: II 2 (1) G EEx [ia] ib IIC T6

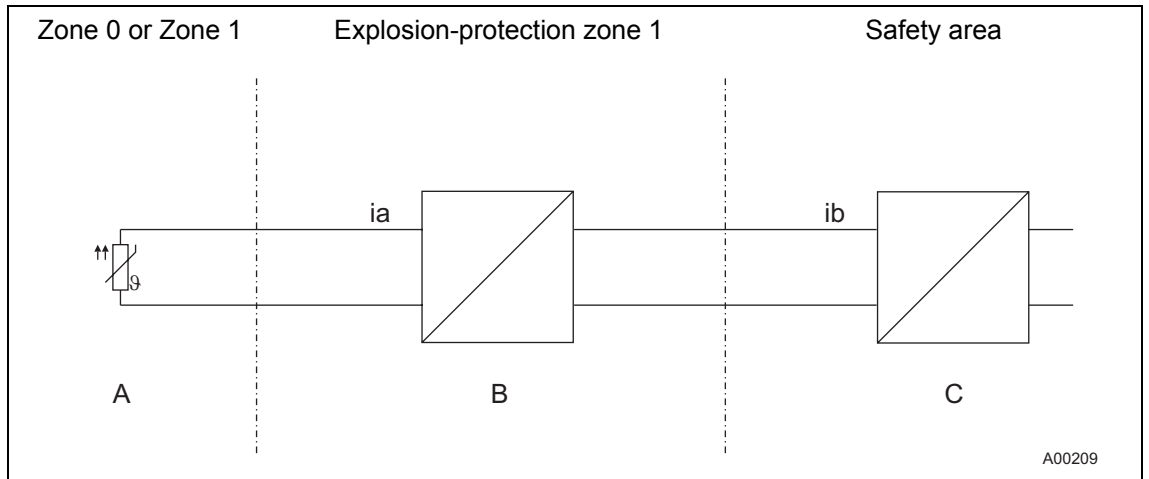

Fig. 7

- A Sensor
- B Transmitter in housing with IP 20 level of protection
- C Power supply [EEx ib]

For instruments in zone 1, the input for the repeater must be at minimum in [EEx ib] design.

The sensor must be used by the user in accordance with applicable ignition-protection standards. It can be installed in zone 1 or zone 0.

4.4.4 Zone 1 (20)

Transmitter design: II 2G (1D) EEx [iaD] ib IIC T6

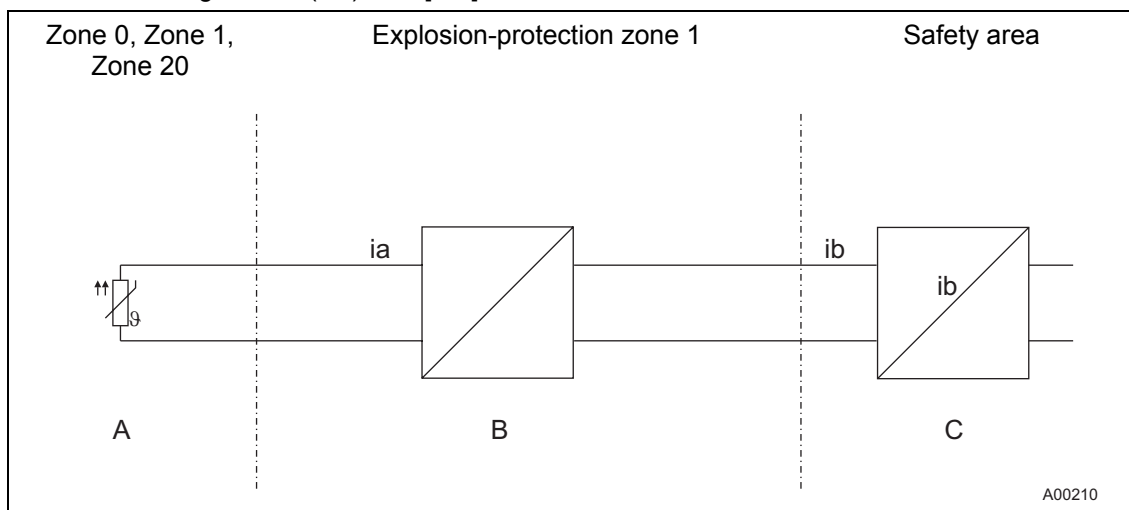

Fig. 8

- A Sensor
- B Transmitter in housing with IP 20 level of protection
- C Power supply [EEx ib]

For instruments in zone 1, the input for the repeater must be at minimum in [EEx ib] design.

The sensor must be used by the user in accordance with applicable ignition-protection standards. It can be installed in zone 0, zone 1 or zone 20.

4.4.5 Zone 2

Transmitter design: II 3G EEx nA II T6

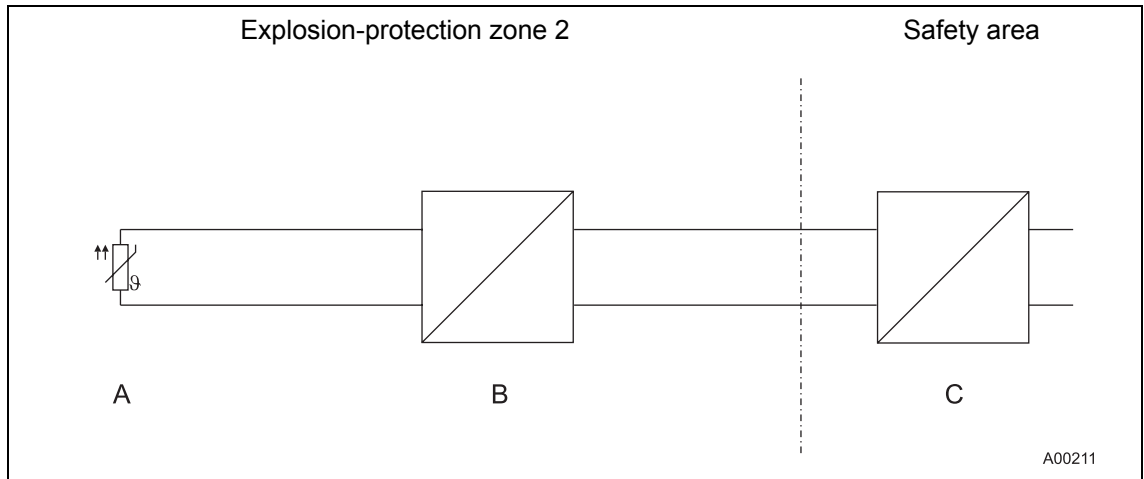

Fig. 9

- A Sensor
- B Transmitter in housing with IP 54 level of protection
- C Transmitter power supply

For instruments in zone 2, the transmitter must be installed in its own housing with a minimum of IP 54 level of protection.

Ensure that in case of a disturbance the supply voltage cannot exceed 40 % of the normal voltage.

5 Startup Operation



Important

The transmitter is immediately ready for operation after mounting and installation of the connections. The parameters are set at the factory.

The connected wires must be checked for firm seating. Only firmly seated wires ensure full functionality.

6 Appendix

6.1 Additional documents

- Operating Instruction (OI/TTR200)
- Data Sheet (DS/TTR200)

6.2 Permits and certifications



Important

All documentation, declarations of conformity and certificates are available in the download area of ABB.

www.abb.com/temperature



EG-Konformitätserklärung
EC-Certificate of Compliance

ABB Automation Products GmbH
Borsigstr. 2
D-63755 Alzenau
Germany

Erklärt, dass die Produkte der Geräteart: <i>Declare that the products of device type:</i>	Temperatur Messumformer Temperature Transmitter
Modell- / Typebezeichnung: <i>Model- / type name:</i>	TTR200, TTR300
Produktnummer: <i>Product number:</i>	TTR200-..., TTR300-...
Konform zu EG-Richtlinien: <i>Conform to EC-directives:</i>	94/9/EG (ATEX) 89/336/EWG (EMV/EMC)
EG-Baumusterprüfbescheinigung: <i>EC-Type examination certificate:</i>	PTB 05 ATEX 2017 X
Relevante Normen: <i>Related Standards:</i>	EN61326-1 : 2006 EN50014 (1997), EN50020 (2002),
Qualitätssicherung Produktion <i>Production Quality notification:</i>	PTB 99 ATEX -Q004-...
entspricht. <i>complies.</i>	

Alzenau 19 March 2008

i.V. Reiner Laurinat
Leiter Qualitätsmanagement
Quality Manager

i.A. Harald Müller
Leiter Hardwareentwicklung
R&D Manager Hardware

ABB Automation Products GmbH

ABB provides expert and comprehensive consulting services in more than 100 countries worldwide.

www.abb.com/temperature

ABB is continually improving its products. As a result, technical information in this document is subject to change.

Printed in the Fed. Rep. of Germany (08.2008)

© ABB 2008

3KXT241001R4401



ABB Limited

Salterbeck Trading Estate
Workington, Cumbria
CA14 5DS
UK
Tel: +44 (0)1946 830 611
Fax: +44 (0)1946 832 661

ABB Inc.

125 E. County Line Road
Warminster, PA 18974
USA
Tel: +1 215 674 6000
Fax: +1 215 674 7183

ABB Automation Products GmbH

Borsigstr. 2
63755 Alzenau
Germany
Tel: +49 551 905-534
Fax: +49 551 905-555
CCC-support.deapr@de.abb.com