

INSTRUCTION MANUAL
Water & Industrial Analytics
Advantage Series
Type TB84PH/ORP Analyzer

E67-84-1B



ABB Inc.



WARNING notices as used in this manual apply to hazards or unsafe practices which could result in personal injury or death.

CAUTION notices apply to hazards or unsafe practices which could result in property damage.

NOTES highlight procedures and contain information which assist the operator in understanding the information contained in this manual.

WARNING

INSTRUCTION MANUALS

DO NOT INSTALL, MAINTAIN, OR OPERATE THIS EQUIPMENT WITHOUT READING, UNDERSTANDING AND FOLLOWING THE PROPER ABB INSTRUCTIONS AND MANUALS, OTHERWISE INJURY OR DAMAGE MAY RESULT.

RADIO FREQUENCY INTERFERENCE

MOST ELECTRONIC EQUIPMENT IS INFLUENCED BY RADIO FREQUENCY INTERFERENCE (RFI). CAUTION SHOULD BE EXERCISED WITH REGARD TO THE USE OF PORTABLE COMMUNICATIONS EQUIPMENT IN THE AREA AROUND SUCH EQUIPMENT. PRUDENT PRACTICE DICTATES THAT SIGNS SHOULD BE POSTED IN THE VICINITY OF THE EQUIPMENT CAUTIONING AGAINST THE USE OF PORTABLE COMMUNICATIONS EQUIPMENT.

POSSIBLE PROCESS UPSETS

MAINTENANCE MUST BE PERFORMED ONLY BY QUALIFIED PERSONNEL AND ONLY AFTER SECURING EQUIPMENT CONTROLLED BY THIS PRODUCT. ADJUSTING OR REMOVING THIS PRODUCT WHILE IT IS IN THE SYSTEM MAY UPSET THE PROCESS BEING CONTROLLED. SOME PROCESS UPSETS MAY CAUSE INJURY OR DAMAGE.

NOTICE

The information contained in this document is subject to change without notice.

ABB, its affiliates, employees, and agents, and the authors of and contributors to this publication specifically disclaim all liabilities and warranties, express and implied (including warranties of merchantability and fitness for a particular purpose), for the accuracy, currency, completeness, and/or reliability of the information contained herein and/or for the fitness for any particular use and/or for the performance of any material and/or equipment selected in whole or part with the user of/or in reliance upon information contained herein. Selection of materials and/or equipment is at the sole risk of the user of this publication.

This document contains proprietary information of ABB Inc. and is issued in strict confidence. Its use, or reproduction for use, for the reverse engineering, development or manufacture of hardware or software described herein is prohibited. No part of this document may be photocopied or reproduced without the prior written consent of ABB.

Preface

This publication is for the use of technical personnel responsible for installation, operation, and maintenance of the ABB Advantage Series TB84PH.

Where necessary, this publication is broken into sections detailing the differences between analyzers configured as pH, ORP, or pION. In addition, the configuration section will give a detailed overview of all analyzer functions and how these functions have been grouped into the two major configuration modes: Basic and Advanced.

The Series TB84PH analyzer is delivered with default hardware and software configurations as shown in the table below. These settings may need to be changed depending on the application requirements.

Factory Default Settings			
Software		Hardware	
Instrument		Power Supply PCB	
Mode:	Basic	S301 (Relay Function): ²	NO, Normally Open ³ NC, Normally Close
Analyzer		S301 (Relay Function): ²	NO, Normally Open ³ NC, Normally Close
Type:	pH, Glass	S301 (Relay Function): ²	NO, Normally Open ³ NC, Normally Close
Temperature Sensor			
Type:	3k, Balco		
Temperature Compensation			
Type:	Manual		
Analog Output One		Microprocessor/Display PCB	
Range:	0 to 14 pH	W1 (Configuration Lockout): ³	1-2, Disable Lockout ⁴ 2-3, Enable Lockout
Analog Output Two			
Range:	0 to 140°C		
Relay Output One			
High Setpoint Value:	14.00 pH		
Deadband:	0.10 pH		
Delay:	0.0 mins		
Relay Output Two			
High Setpoint Value:	14.00 pH		
Deadband:	0.10 pH		
Delay:	0.0 mins		
Relay Output Three			
Diagnostics:	Instrument		
Damping			
Value:	0.5 Seconds		
Sensor Diagnostics			
State:	Off (Disabled)		
Safety Mode One			
Failed Output State:	Low		
Safety Mode Two			
Failed Output State:	Low		
Spike Output ¹			
Level:	0%		

¹ Feature available only in Advanced programming.
² See Figure 3-6 for switch locations.
³ See Figure 8-16 for jumper location.
⁴ Bold text indicates default hardware settings.

List of Effective Pages

Total number of pages in this manual is 190, consisting of the following:

Page No.

Change Date

Table of Contents

SECTION 1 - INTRODUCTION	1-1
OVERVIEW	1-1
INTENDED USER	1-2
FEATURES	1-2
EQUIPMENT APPLICATION	1-4
INSTRUCTION CONTENT	1-4
HOW TO USE THIS MANUAL	1-6
GLOSSARY OF TERMS AND ABBREVIATIONS	1-6
REFERENCE DOCUMENTS	1-9
NOMENCLATURE	1-9
SPECIFICATIONS	1-10
ACCESSORIES	1-12
SECTION 2 - ANALYZER FUNCTIONALITY AND	
OPERATOR INTERFACE CONTROLS	2-1
INTRODUCTION	2-1
ANALYZER OVERVIEW	2-1
USER INTERFACE	2-2
MODULAR ELECTRONIC ASSEMBLIES	2-2
TEMPERATURE COMPENSATION	2-3
ANALOG OUTPUTS	2-3
RELAY OUTPUTS	2-3
High or Low Set Point	2-4
High or Low Cycle Timer	2-4
Cleaner	2-5
DAMPING	2-6
DIAGNOSTICS	2-6
Analyzer	2-7
Sensor	2-7
Spike Output	2-7
SECTION 3 - INSTALLATION	3-1
INTRODUCTION	3-1
SPECIAL HANDLING	3-1
UNPACKING AND INSPECTION	3-2
LOCATION CONSIDERATIONS	3-3
HAZARDOUS LOCATIONS	3-3
RADIO FREQUENCY INTERFERENCE	3-3
MOUNTING	3-4
Pipe Mounting	3-4
Hinge Mounting	3-5
Wall Mounting	3-6
Panel Mounting	3-7
WIRING CONNECTIONS AND CABLING	3-9
Power Wiring	3-10
Analog Output Signal Wiring	3-11
Relay Output Signal Wiring	3-11
Advantage Series (TBX5) Sensor Wiring	3-13
Non-Advantage Series (TB5) Sensor Wiring	3-14
GROUNDING	3-17
OTHER EQUIPMENT INTERFACE	3-17
INSTRUMENT ROTATION	3-18
SECTION 4 - OPERATING PROCEDURES	4-1
INTRODUCTION	4-1

OPERATOR INTERFACE CONTROLS REVIEW	4-2
Liquid Crystal Display (LCD)	4-2
Multi-Function Smart Keys	4-3
MODES OF OPERATION	4-5
HOLD ICON	4-6
FAULT ICON	4-7
SPIKE ICON	4-7
RELAY ICONS	4-7
SECTION 5 - MEASURE MODE	5-1
INTRODUCTION	5-1
BOREDOM SWITCH	5-1
PRIMARY DISPLAY	5-1
SECONDARY DISPLAY	5-2
FAULT INFORMATION Smart Key	5-2
SPT Smart Key	5-2
MENU Smart Key	5-3
SECTION 6 - CALIBRATE MODE	6-1
INTRODUCTION	6-1
CALIBRATE STATES OF OPERATION	6-1
Process Sensor Calibrate State	6-3
One-Point Calibrate State	6-4
Two-Point Calibrate State	6-5
Temperature Calibrate State	6-8
Edit Calibrate State	6-10
Reset Calibrate State	6-12
Analog Output One Calibrate State	6-12
Analog Output Two Calibrate State	6-13
SECTION 7 - OUTPUT/HOLD MODE	7-1
INTRODUCTION	7-1
OUTPUT/HOLD STATES OF OPERATION	7-1
Hold/Release Hold Output State	7-2
Analog Output One Rerange State	7-6
Analog Output Two Rerange State	7-7
Damping State	7-8
Spike State	7-10
SECTION 8 - CONFIGURE MODE	8-1
INTRODUCTION	8-1
PRECONFIGURATION DATA REQUIRED	8-1
CONFIGURE VIEW/MODIFY STATE	8-1
BASIC/ADVANCED PROGRAMMING MODE	8-3
MODIFY CONFIGURE STATES OF OPERATION	8-4
Analyzer State (Basic/Advanced)	8-7
pH Analyzer State (Basic/Advanced)	8-8
ORP and pION States (Basic/Advanced)	8-9
Ion Concentration State (Advanced)	8-10
Temperature Sensor State (Basic/Advanced)	8-12
Temperature Compensation State (Basic/Advanced)	8-12
Manual Nernstian State (Basic/Advanced)	8-13
Automatic Nernstian State (Basic/Advanced)	8-14
Automatic Nernstian With Solution Coefficient State (Advanced)	8-15
Analog Output One State (Basic/Advanced)	8-16
Linear Output State (Basic/Advanced)	8-16

Non-Linear Output State (Advanced)	8-18
Analog Output Two State (Basic/Advanced)	8-21
Relay Output One (Basic/Advanced)	8-22
Relay Output Two (Basic/Advanced)	8-24
Relay Output Three (Basic/Advanced)	8-25
Setpoint Relay Output (Basic/Advanced)	8-27
Diagnostic Relay Output (Basic/Advanced)	8-28
Cycle Timer Relay Output (Advanced)	8-29
Cleaner Relay Output (Advanced)	8-31
Damping State (Basic/Advanced)	8-33
Diagnostics State (Basic/Advanced)	8-35
Safe Mode One State (Basic/Advanced)	8-35
Safe Mode Two State (Basic/Advanced)	8-36
Spike State (Advanced)	8-36
CONFIGURATION LOCKOUT	8-37
SECTION 9 - SECURITY MODE	9-1
INTRODUCTION	9-1
SECURITY STATE OF OPERATION	9-1
SECTION 10 - SECONDARY DISPLAY MODE	10-1
INTRODUCTION	10-1
SECONDARY DISPLAY STATE OF OPERATION	10-1
SECTION 11 - SETPOINT/TUNE MODE	11-1
INTRODUCTION	11-1
SETPOINT/TUNE STATES OF OPERATION	11-1
Setpoint Relay Output (Basic/Advanced)	11-1
Diagnostic Relay Output (Basic/Advanced)	11-3
Cycle Timer Relay Output (Advanced)	11-4
Cleaner Relay Output (Advanced)	11-6
SECTION 12 - UTILITY MODE	12-1
INTRODUCTION	12-1
FACTORY/USER STATE	12-1
User State	12-1
Advanced/Basic Programming Mode User State	12-2
Reset Configuration User State	12-3
Reset Security User State	12-4
Reset All User State	12-5
Soft Boot User State	12-6
SECTION 13 - DIAGNOSTICS	13-1
INTRODUCTION	13-1
FAULT CODES	13-1
Problem Codes	13-2
Error Codes	13-4
Calibration Diagnostic Messages	13-5
Additional Diagnostic Messages	13-6
SECTION 14 - TROUBLESHOOTING	14-1
INTRODUCTION	14-1
ANALYZER TROUBLESHOOTING	14-1
SENSOR TROUBLESHOOTING	14-5
Visual Sensor Inspection	14-6
Sensor Electronic Test	14-7
SECTION 15 - MAINTENANCE	15-1

INTRODUCTION	15-1
PREVENTIVE MAINTENANCE	15-1
Cleaning the Sensor	15-2
SECTION 16 - REPLACEMENT PROCEDURES	16-1
INTRODUCTION	16-1
ELECTRONIC ASSEMBLY REMOVAL/REPLACEMENT	16-1
FRONT BEZEL ASSEMBLY REMOVAL/REPLACEMENT	16-2
SHELL ASSEMBLY REMOVAL/REPLACEMENT	16-2
REAR COVER ASSEMBLY REMOVAL/REPLACEMENT	16-3
SECTION 17 - SUPPORT SERVICES	17-1
INTRODUCTION	17-1
RETURN MATERIALS PROCEDURES	17-1
REPLACEMENT PARTS	17-1
RECOMMENDED SPARE PARTS KITS	17-2
APPENDIX A - TEMPERATURE COMPENSATION	A-1
GENERAL	A-1
NERNSTIAN TEMPERATURE COMPENSATION	A-1
SOLUTION COEFFICIENT	A-2
APPENDIX B - PROGRAMMING TEXT STRING GLOSSARY	B-1
GENERAL	B-1
GLOSSARY OF PROGRAMMING TEXT PROMPTS	B-1
APPENDIX C - CONFIGURATION WORKSHEETS	C-1

Safety Summary

GENERAL WARNINGS	<p>Equipment Environment All components, whether in transportation, operation or storage, must be in a noncorrosive environment.</p> <p>Electrical Shock Hazard During Maintenance Disconnect power or take precautions to insure that contact with energized parts is avoided when servicing.</p>
-------------------------	--

SPECIFIC CAUTIONS	<p>To prevent possible signal degradation, separate metal conduit runs are recommended for the sensor, signal and power wiring.</p> <p>Automatic Nernstian With Solution Coefficient compensation can only be used for processes that are extremely repeatable.</p>
--------------------------	---

**SPECIFIC
WARNINGS**

Use this equipment only in those classes of hazardous locations listed on the nameplate. Uses in other hazardous locations can lead to unsafe conditions that can injure personnel and damage equipment.

Allow only qualified personnel (refer to INTENDED USER in SECTION 1 - INTRODUCTION) to commission, operate, service or repair this equipment. Failure to follow the procedures described in this instruction or the instructions provided with related equipment can result in an unsafe condition that can injure personnel and damage equipment.

Consider the material compatibility between cleaning fluids and process liquids. Incompatible fluids can react with each other causing injury to personnel and equipment damage.

Use solvents only in well ventilated areas. Avoid prolonged or repeated breathing of vapors or contact with skin. Solvents can cause nausea, dizziness, and skin irritation. In some cases, overexposure to solvents has caused nerve and brain damage. Solvents are flammable - do not use near extreme heat or open flame.

Do not substitute components that compromise the certifications listed on the nameplate. Invalidating the certifications can lead to unsafe conditions that can injure personnel and damage equipment.

Do not disconnect equipment unless power has been switched off at the source or the area is known to be nonhazardous. Disconnecting equipment in a hazardous location with source power on can produce an ignition-capable arc that can injure personnel and damage equipment.

Remove power from the unit and allow at least one minute for the unit to discharge before performing these procedures. Failure to do so constitutes an electrical shock hazard that can injure personnel and damage equipment.

Disconnect the AC line cord or power lines from the operating branch circuit coming from the source before attempting electrical connections. Instruments powered by AC line voltage constitute a potential for personnel injury due to electric shock.

Keep the enclosure and covers in place after completing the wiring procedures and during normal operation. Do not disconnect or connect wiring or remove or insert printed circuit boards unless power has been removed and the flammable atmosphere is known NOT to be present. These procedures are not considered normal operation. The enclosure prevents operator access to energized components and to those that can cause ignition capable arcs. Failure to follow this warning can lead to unsafe conditions that can injure personnel and damage equipment.

All error conditions are considered catastrophic. When such an error has been reported, the analyzer should be replaced with a known-good analyzer. The non-functional analyzer should be returned to the factory for repair. Contact the factory for a Return Materials Authorization (RMA) number.

SECTION 1 - INTRODUCTION

OVERVIEW

The TB84PH Advantage Series is a line-powered pH/ORP/pION (i.e., specific ion) analyzer with state-of-the-art electronics, internal and external diagnostic functionality, an innovative user-interface having *HotKey* capability, two user-selectable modes of operation, and DIN-size packaging.

Diagnostic interrogation of the internal circuitry and external sensing devices is continually conducted to ensure accuracy and immediate notification of problem situations when they occur. Detection of sensor integrity includes pH electrode damage, sensor coating, sensor out-of-liquid, ground-loop detection, and short/open sensor cabling. Additional software functions monitor slope, asymmetric potential, process variable over/under range, and temperature over/under range. If these diagnostic conditions occur, the analyzer can be programmed to induce a repetitive modulation of a given magnitude in the output current or can be link to a relay output thus providing the ability to alert personnel of a problem condition.

The analyzer packaging conforms to DIN standards and has mounting options that include pipe, wall, hinge, and panel installations. Due to the modular design of the electronics, changing the analyzer sensing capability to other analytical properties such as solution conductivity can be quick and easy.

The user interface is an innovative, patent-pending technology which facilitates a smooth and problem-free link between the user and analyzer functionality. The programming structure and multi-function keys reduce programming difficulties by providing a toggle between *Basic* and *Advanced* functions.

INTENDED USER

Installation Personnel	Should be an electrician or a person familiar with the National Electrical Code (NEC), or equivalent, and local wiring regulations. Should have a strong background in installation of analytical equipment.
Application Technician	Should have a solid background in pH/ORP/pION measurements, electronic instrumentation, and process control and be familiar with proper grounding and safety procedures for electronic instrumentation.
Operator	Should have knowledge of the process and should read and understand this instruction book before attempting any procedure pertaining to the operation of the TB84PH Advantage Series analyzer.
Maintenance Personnel	Should have a background in electricity and be able to recognize shock hazards. Personnel must also be familiar with electronic process control instrumentation and have a good understanding of troubleshooting procedures.

FEATURES

Diagnostic Sensor Capability	The TB84PH Advantage Series analyzer offers the necessary hardware and software for full compatibility with TBX5 Advantage Series pH/ORP/pION sensors. These sensors are equipped with the new NEXT STEP reference technology and are well suited for harsh process streams.
Multiple Applications	Accepts inputs from standard glass pH electrodes, antimony pH electrodes, gold or platinum Oxidation-Reduction Potential (ORP) electrodes, or any specific ion electrode. A custom electrode configuration is also available which uses information regarding the asymmetric potential and isopotential point. Isolated analog outputs allows use in grounded or floating circuits. Relay outputs provide setpoint control, cycle-timer control, diagnostic alarming, and cleaner operation.

Automatic Temperature Compensation	<p>Menu-selectable choices provide the user with a wide range of easily configurable selections for temperature compensation.</p> <ol style="list-style-type: none"> 1. Automatic Nernstian 2. Automatic Nernstian with Solution Coefficient 3. Manual Nernstian
Wide Rangeability	<p>Analog output spans do not affect the display range of -2.00 to +16.00 pH (-2000 to +2000 mV for ORP and specific ion). Minimum and maximum process variable output spans are 1.0 pH (100 mV for ORP and specific ion) and 14 pH (3998 mV for ORP and specific ion), respectively. Minimum and maximum temperature output spans are 10 °C (18 °F) and 140 °C (284 °F), respectively.</p>
Innovative User Interface	<p>Using four Smart Keys and a custom Liquid Crystal Display (LCD), multiple functions have been assigned to each key and are displayed at the appropriate time depending on the programming environment. This patent-pending technology reduces the number of keys while maintaining the maximum amount of functionality and allows for the use of a larger, more visible LCD.</p>
Simple Calibration	<p>One- and two-point calibrations are available and smoothly guide the user through each calibration step. Provisions for viewing and modifying the sensor calibration data are also included. Temperature calibration uses smart calibration routines which determine the appropriate adjustments based on previous calibration data.</p>
NEMA 4X/IP65 Housing	<p>Suitable for corrosive environments, the electronics enclosure is a corrosion resistant, aluminum alloy. A chemical resistant polyurethane powder coating provides external protection.</p>
Suitable for Hazardous Locations	<p>The TB84PH Advantage Series analyzer design complies with industry standards for Division 2 and non-incendive installations (certification pending).</p>
Diagnostic Indication	<p>The custom LCD has dedicated icons which act as visible indications of an output hold, fault, diagnostic spike, and energized relay condition.</p>

Secure Operation	A hardware lockout feature prevents unauthorized altering of instrument configuration parameters while allowing other analyzer functions to be fully accessible. Software security codes can also be assigned to the Configure, Calibrate, Output/Hold, and Setpoint/Tune Modes of Operation.
Compact Packaging	Industry standard ½-DIN size maintains standard panel cut outs and increases installation flexibility by providing pipe, wall, hinge, and panel mounting options.
Nonvolatile Memory	In the event of a power failure, the nonvolatile memory stores and retains the configuration and calibration data.
Analyzer Diagnostics	Built-in electronic circuitry and firmware routines perform a series of self-diagnostics, monitoring such areas as memory and input circuit integrity. Irregularities are indicated for maintenance purposes.

EQUIPMENT APPLICATION

The TB84PH Advantage Series analyzer can be used anywhere pH, ORP, or specific ion measurements are desired.

INSTRUCTION CONTENT

Introduction	This section provides a product overview, a description of each section contained in this manual, and how each section should be used. This section also has a glossary of terms and abbreviations, a list of reference documents on related equipment and/or subjects, the product identification (nomenclature), and a comprehensive list of hardware performance specifications including accessories and applicable certification information.
Analyzer Functionality And Operator Interface Controls	This section provides a short description on the functionality of the TB84PH Advantage Series analyzer.
Installation	This section provides information on analyzer installation such as unpacking directions, location considerations, analyzer mounting options and procedures, wiring instructions, sensor connections, and grounding procedures.

Operating Procedures	This section addresses the operator interface controls and their function. The Mode of Operation and LCD status icons are listed and their functions are described.
Measure Mode	This section describes the normal analyzer mode of operation which includes the primary and secondary display, Fault Information Smart Key, and Menu Smart Key functions.
Calibrate Mode	This section provides sensor and analyzer calibration procedures and calibration data descriptions.
Output/Hold Mode	This section describes the Output/Hold States of Operation including hold, rerange, damping, and spike features.
Configure Mode	This section defines the required actions to establish and program the analyzer configuration.
Security Mode	This section provides the procedures necessary to set and clear analyzer security codes.
Secondary Display Mode	This section provides the procedure necessary to set the information displayed in secondary display of the Measure Mode.
Utility Mode	This section defines the reset options and Basic/Advanced programming toggle.
Diagnostics	This section provides a description of the diagnostic tools available to aid with analyzer servicing. This section also provides a listing of displayed faults and the corrective action to be taken.
Troubleshooting	This section provides an analyzer and sensor troubleshooting guide to help determine and isolate problems.
Sensor Maintenance	This section provides cleaning procedures for pH/ORP/pION sensors.
Repair/Replacement	This section includes procedures for analyzer assembly and sensor replacement.
Support Services	This section provides a list of replacement parts unique to the TB84PH Advantage Series analyzer.
Appendix A	This section provides temperature compensation information.

Appendix B This section provides a glossary of text prompts used in the secondary display during analyzer programming.

Appendix C This section provides a configuration worksheet used to record the analyzer's configuration and shows default values when a configuration reset is performed.

HOW TO USE THIS MANUAL

For safety and operating reasons, reading and understanding this product instruction manual is critical. Do not install or complete any tasks or procedures related to operation until doing so.

The sections of this product instruction are sequentially arranged as they relate to initial start-up (from UNPACKING to REPAIR/REPLACEMENT PROCEDURES). After initial start-up, refer to this instruction as needed by section.

GLOSSARY OF TERMS AND ABBREVIATIONS

Table 1-1. Glossary of Terms and Abbreviations

Term	Description
Asymmetric Potential	The electrical potential across the measuring and reference half-cells of an electrochemical sensor at the Isopotential Point.
Boredom Switch	An automatic timer built into the TB84PH Advantage Series analyzer that returns the instrument to the Measure Mode of Operation if a user has entered another mode of operation and has not initiated another action for twenty minutes.
EEPROM	Electrically Erasable Programmable Read Only Memory. A type of non-volatile memory that can be electrically programmed and erased.
Efficiency	A value that represents the percentage of the theoretical, Nernstian temperature compensated output from an electrochemical sensor.
EPROM	Erasable Programmable Read Only Memory. This memory holds the operational program for the microcontroller integral to the analyzer.
Ground Loop	A path between two separate ground connections thus allowing unwanted current flow through the measurement cabling or circuitry.

Term	Description
HotKey	A short-cut that moves the user from the View Configure State to the Modify Configure State of Operation.
Icon	A text or symbolic image representing a set function, condition, or engineering unit.
Impedance	A measure of the total opposition to current flow in an alternating-current circuit.
Isopotential Point	The potential of an electrochemical sensor that is independent to sample fluid temperature changes.
LCD	Liquid Crystal Display. The custom three and one-half digit primary display, six-character alpha-numeric secondary field, and supporting icons that allow for local readout of the process variable, programming of analyzer functions, and local indication of fault, hold, and relay state conditions.
Non-volatile Memory	Memory that retains programmed information such as configuration and calibration parameters, even when power is removed.
ORP	Oxidation-Reduction Potential. The potential created during a chemical reaction in which one or more electrons are transferred from one atom or molecule to another.
PCB	Printed Circuit Board. A flat board which contains pads for integrated circuit chips, components, connections, and electrically conductive pathways between those elements that function together to form an electronic circuit.
pH	Potential of Hydrogen. A measure of the acidity or alkalinity of a solution, numerically equal to 7 for neutral solutions, increasing with increasing alkalinity and decreasing with increasing acidity.
RTD	Resistive Temperature Detector. An element whose resistance has a relationship with the temperature of its surroundings.
SEEPROM	Serial Electrically Erasable Programmable Read Only Memory. A type of non-volatile memory that can be electrically programmed, erased, and read using serial communication techniques.

Term	Description
Slope	The linear relation between two sets of variables that describes the rate of change between these variables.
Specific Ion (pION)	Potential of a Specific Ion. A potential produced by an Ion Specific Electrode that varies logarithmically with the ion's concentration.
Solution Coefficient	A method of temperature compensation that compensates for a constant change in ion dissociation relative to temperature. The units are in 0.000 pH per °C for pH and 0.00 mV per °C for ORP, pION, and Ion Concentration.
Valence	An integer used to represent the capacity of an atom or group of atoms to combine in specific proportions with other atoms or groups of atoms.

REFERENCE DOCUMENTS

Table 1-2. Reference Documents

Number	Document
E67-21-3	pH/ORP Sensors for Process Monitoring
WTPEEUS520003A0	TB84PH Advantage Series Product Specification
TP93-11	Validation of Field pH Sensors
TP90-2	Calibration and Troubleshooting of pH Loops
TP96-1	Temperature Another Wild Card in pH Control

NOMENCLATURE

Position	5	6	7	8	9	10	11	12	13	
Type	TB84	G	G	G	G	G	G	G	G	Advantage Series Analyzer

P	H										Input
E	C										pH/ORP/pION
T	E	1									Four-Electrode Conductivity
T	C	2	0								Two-Electrode Conductivity
				0							Toroidal Conductivity
					0						Programming
											Basic
											Advanced
											Reserved (PI Controller)
											None
											Reserved (Remote Analyzer)
											None
											Housing Type
											Powder Coated, Alodined
											Aluminum
											Mounting Hardware
											None
											Pipe
											Hinge
											Panel
											Wall
											Agency Approval (Pending)
											None
											FM
											CSA
											CENLEC
											Label
											None
											Stainless Steel
											Mylar

NOTE: A single digit or letter must be used in each nomenclature position.

SPECIFICATIONS

Table 1-3. Specifications

Property	Characteristic/Value
Process Display Range pH ORP pION	-2 to +16.00 pH -1999 to +1999 mV -1999 to +1999 mV
Temperature Display Range	0° to 140°C (32° to 284°F).
Resolution, Display pH ORP pION Temperature	0.01 pH 1 mV 1 mV 1°C, 1°F.
Accuracy, Display pH ORP pION Temperature	±0.01 pH ±1 mV ±1 mV 1°C
Accuracy, Output	±0.02 mA at full scale output setting
Nonlinearity, Display pH ORP pION Temperature	±0.01 pH ±1 mV ±1 mV 1°C
Nonlinearity, Output	±0.02 mA at full scale output setting
Repeatability, Display pH ORP pION Temperature	±0.01 pH ±1 mV ±1 mV 1°C
Repeatability, Output	±0.02 mV at full scale output setting
Stability, Display pH ORP pION Temperature	±0.01 pH ±1 mV ±1 mV 1°C
Stability, Output	±0.02 mV at full scale output setting
Temperature Compensation	Manual Nernstian Automatic Nernstian Automatic Nernstian with Solution Coefficient
Input Types pH ORP pION Temperature	Glass, Antimony, Custom Isopotential & Asymmetric Potential Platinum, Gold Sodium, Chloride, Sulfide, etc. 3 kohm Balco, Pt100
Dynamic Response	3 sec. for 90% step change at 0.0 sec. damping.
Ambient Temperature Effect pH ORP pION Temperature Output	±0.007 pH/°C @ 95% Relative Humidity ±0.4 mV/°C @ 95% Relative Humidity ±0.4 mV/°C @ 95% Relative Humidity ±0.16 °C/°C @ 95% Relative Humidity ±0.008 mA/°C @ 95% Relative Humidity

Property	Characteristic/Value
Output Minimum Span pH ORP pION Temperature	1.00 pH 100 mV 100 mV 10 °C
Output Maximum Span (full scale settings) pH ORP pION Temperature	14 pH (0 to 14 pH) 3998 mV (-1999 to 1999 mV) 3998 mV (-1999 to 1999 mV) 140 °C, 284 °F (0 to 140 °C, 32 to 284 °F)
Damping	Continuously adjustable from 0.0 to 99.9 seconds
Supply Voltage Ranges	93.5 to 276 Vac, 50 to 60 Hz, Single Phase Maximum Consumption 17 VA
Analog Output Ratings	Two completely isolated 0/4 to 20 mAdc outputs 750 ohms Maximum Load Value Output One Fixed to the Process Variable Output Two Software-Selectable to either the Process Variable or Temperature
Relay Output Ratings	Three SPDT contacts with LCD icon indicators Hardware configurable for Normally Open or Normally Close Software configurable relay functions include High/Low Setpoint with adjustable Deadband and Time Delay, High/Low Cycle Timer with adjustable Duty Cycle and Time Delay, Diagnostic Alarm, and Cleaner Control Maximum AC Capacity Values of 100 VA, 240 Vac, and 3 A Maximum DC Capacity Values of 50 W, 24 Vdc, and 3 A
Power Supply Effect	±0.005% of full scale span per volt
Turn-On Time	2 seconds typical, 4 seconds maximum
Maximum Sensor Cable Length	100 ft (30.5 m)
Sensor Diagnostic pH ORP pION	Glass and Reference Impedance, Open and Short Cabling, Efficiency and Asymmetric Potential Check Reference Impedance, Open and Short Cabling, Efficiency and Asymmetric Potential Check Reference Impedance, Open and Short Cabling, Efficiency and Asymmetric Potential Check
Diagnostic Notification Analog Mode	Local indication via a FAULT and SPIKE icon. Programmable output pulse on Analog Output One, 0 to 16 mA for 1 seconds on 6 second cycles
Environmental Operating temperature LCD Range Storage temperature	-20° to 60°C (-4° to 140°F) -20° to 60°C (-4° to 140°F) -40° to 70°C (-40° to 158°F)
Mounting Effect	None
Enclosure Classification	NEMA 4X IP65
Size Height Minimum panel depth Maximum panel cutout	144 mm high x 144 mm wide x 171 mm long (5.67 in. high x 5.67 in. wide x 6.75 in. long) 145 mm (5.70 in.) 136.7 mm x 136.7 mm (5.38 in. x 5.38 in.).

Property	Characteristic/Value
Weight	4.2 lb (1.9 kg) without mounting hardware 7.5 lb (3.4 kg) with Pipe Mounting Hardware
EMC Requirements	CE certified: Electromagnetic Emission - EN50082-1: 1994 EN55011: 1991 (CISPR11: 1990) Class A Electromagnetic Immunity - EN50082-2: 1996 EN61000-4-2: 1995 6 kV Contact 6 kV Indirect EN61000-4-3: 1997 10 V/m (unmodulated, rms) 80 to 1000 MHz EN61000-4-4: 1995 1 kV Signal Lines 5/50 T _r /T _h nS 5 kHz EN61000-4-8: 1994 50 Hz 30A(rms)/m ENV50141: 1994 10 V (unmodulated, rms) 0.15 to 80 MHz 80% AM (1kHz) 150 ohms, source impedance ENV50204: 1996 10 V/m (unmodulated, rms) 900 ±5 MHz 50% duty cycle 200 Hz Low Voltage - EN61010-1:1993 (Category II)
Agency Approvals ¹ (pending) FM CSA	Non-incendive. Class I, Division 2, Groups A, B, C, and D. Class II, Division 2, Groups F and G. Class III, Division 2. Class I, Division 2, Groups A, B, C, and D. Class II, Division 2, Groups E, F and G. Class III, Division 2.

SPECIFICATIONS SUBJECT TO CHANGE WITHOUT NOTICE

1. Hazardous location approvals for use in flammable atmospheres are for ambient conditions of -25° to 40°C (-13° to 104°F), 86 to 108kPa (12.5 to 15.7 psi) with a maximum oxygen concentration of 21%.

ACCESSORIES

Kits

Part Number	Mounting Kit
4TB9515-0124	Pipe
4TB9515-0125	Hinge
4TB9515-0156	Wall
4TB9515-0123	Panel

Part Number	Description
4TB9515-0164	BNC Adapter
4TB9515-0166	BNC Adapter w/ ½" Cord Grip Fitting
4TB9515-0165	½" Cord Grip Fitting
4TB9515-0191	PG9 Cord Grip Fitting
4TB9515-0198	Complete Cord Grip Set (Three PG9 p/n 4TB9515-0191 & Two ½" p/n 4TB9515-0165)

See Section 17, Support Services, for a complete list of available kits.

Sensors

Nomenclature ¹	Fitting Type
TBX551, TB551	In-line Twist Lock, Submersible
TBX556, TB556	In-line Threaded, Submersible
TBX557, TB557	Ball Valve Insertion, Hot Tap
TBX561, TB561	Sterilizable, In-line
TBX564, TB564	High Pressure Hot Tap
TBX567, TB567	High Pressure In-line

¹ TBX5 Advantage Series Sensors required for advanced sensor diagnostics. BNC Adapter Kit required for TB5 Sensors with BNC Connector. When using TB5 Sensors with type T (i.e., Pin Lug) terminations, the BNC Adapter p/n 4TB9515-0164 is not required. See Section 3, Installation, for more information.

SECTION 2 - ANALYZER FUNCTIONALITY AND OPERATOR INTERFACE CONTROLS

INTRODUCTION

The beginning of this section contains an overview of the TB84PH pH/ORP/pION Advantage Series analyzer functionality and important information for configuration personnel. The latter part of this section discusses the operator interface controls. It includes descriptions of the analyzer modes and faceplate controls.

ANALYZER OVERVIEW

The TB84PH Advantage Series analyzer provides two analog output signals that can be configured to be proportional to either the output of any electrochemical sensor having a DC voltage output between -2000 and +2000 mV and/or a 3k Balco or Pt100 RTD. This includes sensors requiring electrometer type detectors such as pH, ORP, and specific ion (i.e., pION) sensors. In addition to the two analog outputs, any of the three integral relay outputs can be configured as a high or low setpoint controller, cycle-timer controller, diagnostic alarm, or cleaner controller. In this manner, the TB84PH Advantage Series analyzer provides a means by which to monitor and control the pH, ORP, pION, or Ion Concentration of a process fluid.

This analyzer is equipped with internal diagnostic capabilities allowing for the detection of any potential problems with the electronics and operation of firmware. Diagnostic capability also includes the detection of sensor integrity such as pH glass electrode impedance, reference electrode impedance, ground-loop detection, open and shorted cabling, process variables out of range, and incorrect calibration values.

USER INTERFACE

The user interface consists of a tactile keypad having four Smart keys, one hidden key, and a custom LCD. The LCD has a three and one-half digit numeric region that displays the process variable, a six-digit alphanumeric region that displays secondary information and programming prompts, and several status-indicating and programming icons.

Using a novel approach (patent-pending), each of the four keys is located under a given set of icons. In each of the instrument modes and mode states, one icon over any given key will be illuminated and will represent that key's function. These Smart Key assignments will vary as the user enters into different programming modes and states. In addition to the Smart Key assignments, text strings located in the six character alphanumeric field (i.e., secondary display) are used as programming prompts. The end result is an interface that provides a great deal of flexibility and functionality.

MODULAR ELECTRONIC ASSEMBLIES

The TB84PH Advantage Series analyzer consists of three separate PCB assemblies that concentrate specific circuit functionality onto each of the three boards. This modular design allows for the ability to change the instrument from one of four types of instruments: pH/ORP/pION, four-electrode conductivity, two-electrode conductivity, and toroidal conductivity. In addition, analyzer repairs can be quickly accomplished by simply replacing the non-functioning board with an operational one.

TEMPERATURE COMPENSATION

The process temperature can be monitored using one of two types of RTD inputs: 3 kohm Balco and Pt100 (US385). The secondary display area can also be set to display the temperature in degrees Celsius or Fahrenheit when the TB84PH Advantage Series is in the Measure mode of operation.

Since temperature influences the output of electrochemical electrodes as well as the physical properties of the process fluid, several temperature compensation functions are available. Temperature compensation options for pH include Manual Nernstian, Automatic Nernstian, and Automatic Nernstian with Solution Coefficient. Options for ORP and pION include Manual (i.e., No Compensation) and Solution Coefficient.

ANALOG OUTPUTS

The TB84PH Advantage Series analyzer has two analog outputs. These outputs can be either direct or reverse acting and can be software-configured for a range of zero to 20 milliamps or four to 20 milliamps. Both outputs are separately scalable, isolated from the input, and isolated from one another.

The analog outputs provide process information to recorders, data loggers, and control systems. The information transmitted can represent (i.e., be sourced to) process pH, ORP, pION, Ion Concentration, or temperature and be ranged across any portion of the particular measurement range. See Table 1-3, Specification, for minimum and maximum range values.

RELAY OUTPUTS

The TB84PH Advantage Series analyzer has three Form C, SPDT relay outputs. The relays can be independently programmed to perform various functions as required by the application.

These functions include:

- C Process control (Setpoint or Cycle Timer).
- C Diagnostic condition notification.
- C Cleaner control.

High or Low Set Point

High or low set point relays are configurable for any value within the measurement range. Each set point relay output allows for separate programmability of relay function (high or low), set point value, deadband value, and delay.

The example shown in Figure 2-1 illustrates a high set point relay output of 10.00 pH with a deadband of 0.10 pH. The relay activates at 10.00 pH and deactivates when the process pH drops below 9.90 pH. The second half of the figure shows the same situation with a 1.0 minute delay before the high set point relay activates. Set point functions are programmable as high or low acting. Setpoint, deadband, and delay value are all tunable parameters available in the Setpoint/Tune Mode of Operation.

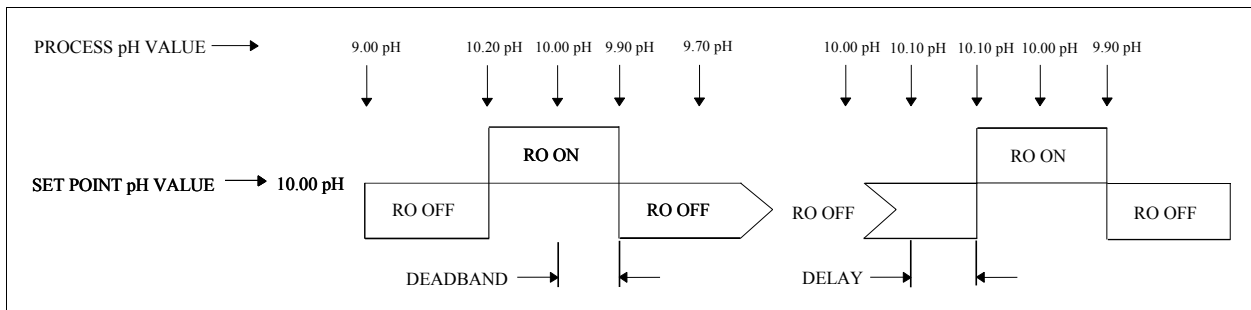

Figure 2-1. High Set Point and Time Delay Example.
High or Low Cycle Timer

High or low cycle timer relays are configurable for any value within the measurement range. A cycle timer relay output allows for separate programmability of relay function (high or low), set point value, cycle time, and on time.

The example shown in Figure 2-2 illustrates a cycle timer that will be active when the process variable exceeds the high set point value of 10.00 pH. Once active, the relay output energizes for the configured on time. As long as the process continues to exceed the set point value, the timer will reset itself at the end of the duty cycle (i.e., cycle time). The set point, cycle time, and on time are all tunable parameters available in the Setpoint/Tune Mode of Operation.

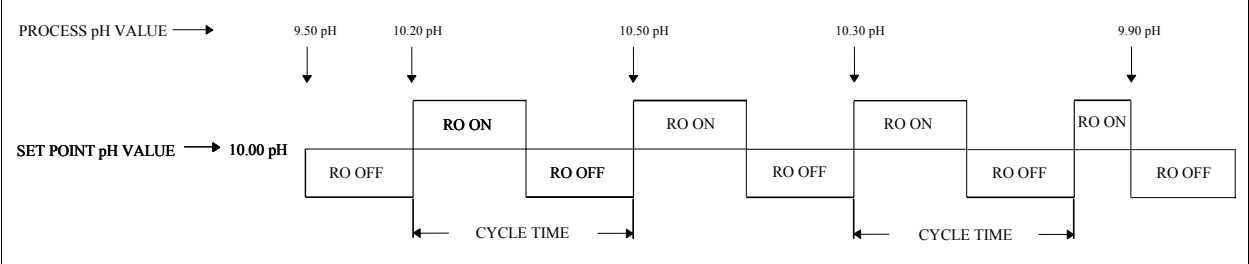

Figure 2.2. Cycle Timer High Set Point Example.

Cleaner

Automatic sensor cleaning can be accomplished using one of the three relay outputs. At a prescribed time interval (i.e., cycle time), a cleaner relay output will energize and thus enable a cleaning device. The cleaner relay will remain energized for a configured cleaning period (i.e., on time). Since many cleaning devices use cleaning solutions that can affect the process measurement, the analog and non-cleaner relay outputs can be held during the cleaning period. If needed, non-cleaner relay outputs can be completely disabled (i.e., de-energized) instead of held. Thus, an operator does not need to be concerned with the possibility of a non-cleaner relay being held in an incorrect state for an undesirable length of time.

In addition to a cleaning period, a recovery period can be programmed to extent any configured hold and/or disabling conditions beyond the clean period. This feature allows cleaning fluids to dissipate or sensor conditions to stabilize before returning to the normal mode of operation.

The set point, cycle time, and on time are all tunable parameters available in the Setpoint/Tune Mode of Operation.

DAMPING

Damping can be adjusted from 0 to 99.9 seconds. This feature is useful in noisy process environments to help stabilize the displayed process variable and output current from excess bounce. Damping can be applied to the displayed and/or analog output values.

Damping simulates a capacitive type lag where reaction to any signal change is slowed according to an entered time constant. For example, a step change will reach approximately 63 percent of its final value in five seconds for five seconds of damping.

DIAGNOSTICS

Diagnostics are provided for both the analyzer and sensor. Diagnostics detection of a serious condition that prevents the instrument from properly functioning enables preset Safe Mode states. These Safe Mode states are configured by the user and forces the outputs to either high and/or low.

For problems that occur that do not render the instrument in a non-functioning state, the user has the option of linking these conditions to a Diagnostic Spike that is superimposed onto Analog Output One and/or to a one or more relay outputs.

If the Diagnostic Spike is enabled, Analog Output One will modulate for one out of every six seconds. The magnitude of the modulation can be set from 0 to 100% of the analyzer's maximum output (i.e., 0 to 16 or 20 mA).

Detection of over forty problem conditions can be enabled by the user if so desired. Diagnostic conditions cause the FAULT and FAULT INFO icons on the display to be energized. Interrogation of each fault condition is available with a single keystroke.

Analyzer

Five critical errors in operation are monitored and linked to the Safe Mode feature. These conditions include inoperable or incorrect input circuit, bad RAM, and damaged EE memory.

Sensor

The analyzer continually performs diagnostic checks on sensor integrity. Inconsistencies

in sensor performance are notified by the FAULT and FAULT INFO icons as well as the Spike Output and/or Diagnostic Relay(s) if configured.

Sensor faults include low measuring electrode impedance (glass pH only), high reference impedance, shorted cable, open cable/sensor out of solution, shorted/open temperature sensor, high and low PV, high and low temperature, and many more. See Section 13, Diagnostics, for more details.

Spike Output

Remote problem condition notification can be initiated by the TB84PH Advantage Series analyzer using the SPIKE State in the Configure Mode. The Spike Output option allows users to program a 0 to 100% (i.e., 0 to 16 mA for 4 to 20 mA configurations or 0 to 20 mA for 0 to 20 mA configurations) pulse that will be impressed on Analog Output One for one second out of a six second repeating cycle should a problem condition be detected. Should the actual output of the analyzer be below mid-scale, the pulse will add current; if above mid-scale, it will subtract current.

SECTION 3 - INSTALLATION

INTRODUCTION

This section of the manual will aid the user in all levels of the installation process. The intention is to provide simple procedures for placing the TB84PH Advantage Series analyzer into service.

SPECIAL HANDLING

Besides the normal precautions for storage and handling of electronic equipment, the analyzer has special static sensitive device (SSD) handling requirements. This equipment contains semiconductors subject to damage by discharge of static electricity; therefore, avoid direct contact with terminal block conductors and electronic components on the circuit board.

To minimize the chances of damage by static electricity, follow these techniques during wiring, service, troubleshooting, and repair.

1. Remove assemblies containing semiconductors from their protective containers only:
 - a. When at a designated static-free work station.
 - b. After firm contact with an antistatic mat and/or gripped by a grounded individual.
2. Personnel handling assemblies with semiconductors must be neutralized to a static-free work station by a grounding wrist strap connected to the station or to a good ground point at the field site.
3. Do not allow clothing to make contact with semiconductors. Most clothing generates static electricity.
4. Do not touch connectors, circuit traces, and components.

5. Avoid partial connection of semiconductors. Semiconductors can be damaged by floating leads. Always install electronic assemblies with power removed. Do not cut leads or lift circuit paths when troubleshooting.

6. Ground all test equipment.

7. Avoid static charges during maintenance. Make sure the circuit board is thoroughly clean around its leads but do not rub or clean with an insulating cloth.

NOTE: An antistatic field service kit, ABB part number 1948385_1, is available for personnel working on devices containing static sensitive components. The kit contains a static dissipative work surface (mat), a ground cord assembly, wrist bands, and alligator clip.

UNPACKING AND INSPECTION

Examine the equipment upon receipt for possible damage in transit. File a damage claim with the responsible transportation company, if necessary. Notify the nearest ABB sales office.

Carefully inspect the packing material before discarding it to make certain that all mounting equipment and any special instructions or paperwork have been removed. Careful handling and installation will insure satisfactory performance of the unit.

Use the original packing material and container for storage. Select a storage environment free of corrosive vapors and extreme temperature and humidity. Storage temperature must not exceed -40 degrees to +70 degrees Celsius (-40 degrees to +158 degrees Fahrenheit).

Remove the protective film from the analyzer lens after the analyzer has been placed in its final installed location.

LOCATION CONSIDERATIONS

When mounting the unit, leave ample clearance for removal of the front bezel and rear cover. Signal wiring should not run in conduit or open trays where power wiring or heavy electrical equipment could contact or interfere with the signal wiring. Twisted, shielded pairs should be used for the best results.

The mounting location should provide easy access for maintenance procedures and not be in a corrosive environment. Excessive mechanical vibrations and shocks as well as relay and power switches should not be in the immediate area. Additionally, this location must conform to the temperature and humidity constraints listed in the Table 1-3, Specifications.

HAZARDOUS LOCATIONS

WARNING

Use this equipment only in those classes of hazardous locations listed on the nameplate. Installations in hazardous locations other than those listed on the nameplate can lead to unsafe conditions that can injure personnel and damage equipment.

Refer to Table 1-3, Specifications, in Section 1 for a list of certifications and approvals applicable to the TB84PH Advantage Series analyzer.

RADIO FREQUENCY INTERFERENCE

Most electronic equipment is affected to some extent by radio frequency interference (RFI). Caution should be exercised with regard to the use of portable communications equipment in areas where this electronic equipment is being used. Post appropriate cautions in the plant as required.

MOUNTING

The TB84PH Advantage Series analyzer can be pipe, hinge, wall, or panel mounted. Figure 3-1 shows the overall dimensions of the TB84PH without mounting hardware. Mounting hardware attaches to the four sets of threaded holes located on the corners of the main housing.

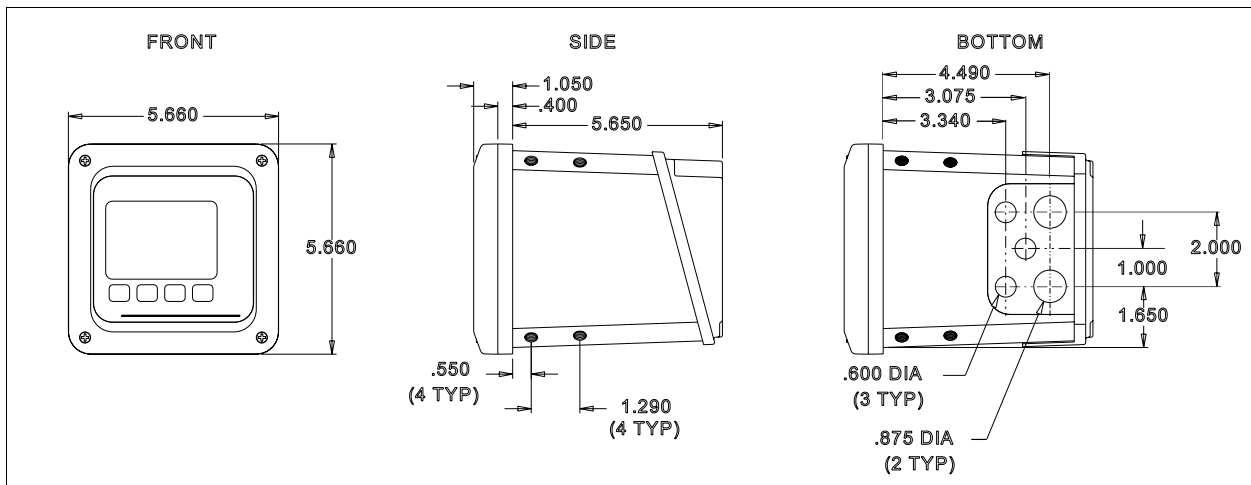

Figure 3-1. Overall Dimensions

Pipe Mounting

The TB84PH Pipe Mount Kit (p/n 4TB9515-0124) contains a pipe and instrument mounting bracket with associated hardware. The pipe mounting bracket can be fitted to pipe sizes as large as two-inches.

Using Figure 3-2 as a reference, mount the TB84PH analyzer as follows:

- 1) Select the desired orientation of the TB84PH analyzer.
- 2) Attach the instrument mounting bracket to the pipe mounting bracket using the supplied 3/8" x 3/4" bolts, 3/8" flat washers, 3/8" lock washers, and 3/8" nuts.
- 3) Attach the pipe mounting bracket to the pipe using the supplied 5/16" U-bolts, 5/16" flat washers, 5/16" lock washers, and 5/16" nuts.
- 4) Attach the instrument to the instrument mounting bracket using the supplied 3/8" x 5/8" bolts, 3/8" flat washers, and 3/8" lock washers.

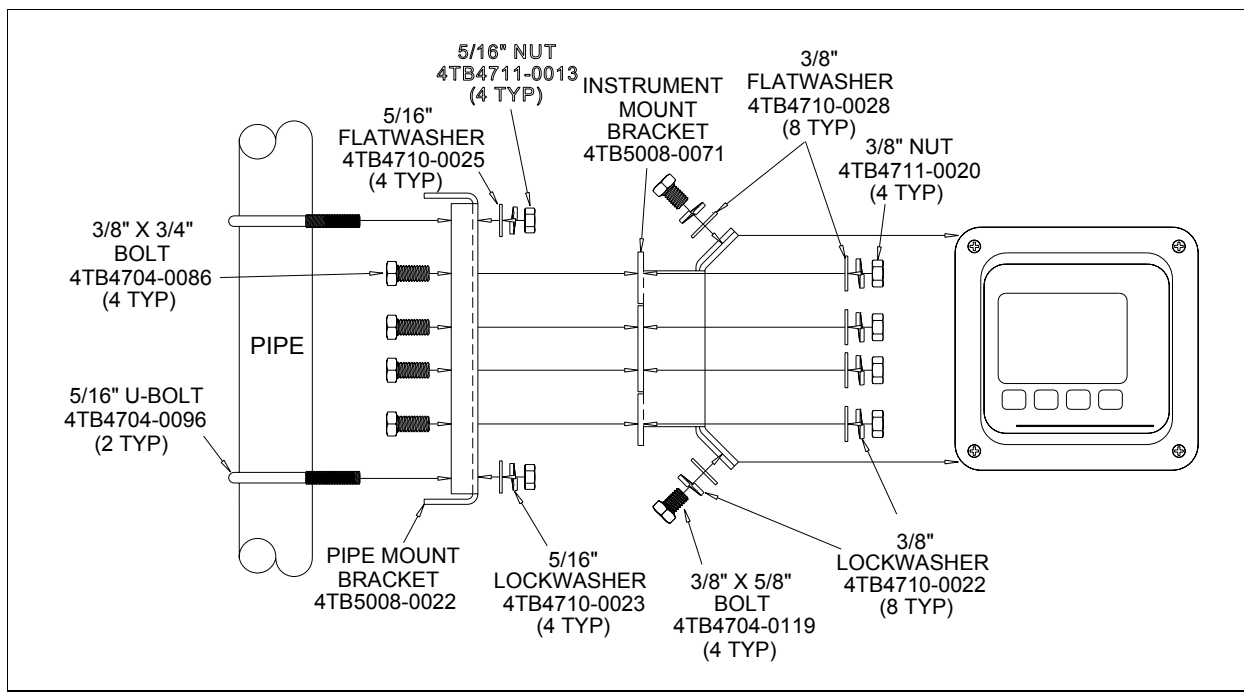

Figure 3-2. Pipe Mount Installation Diagram
Hinge Mounting

The TB84PH Hinge Mount Kit (p/n 4TB9515-0125) contains L- and instrument mounting brackets, a stainless steel hinge, and associated hardware. The Hinge Mount Kit allows for a clear view of the display while maintaining easy access to the rear of the instrument.

Using Figure 3-3 as a reference, mount the TB84PH analyzer as follows:

- 1) Select the desired location and orientation of the TB84PH analyzer.
- 2) Attach the L-bracket to the selected location using the appropriate type of fastener based on the mounting surface material.
- 3) Attach the stainless steel hinge to the L-bracket using the supplied 3/8" x 3/4" bolts, 3/8" flat washers, 3/8" lock washers, and 3/8" nuts.
- 4) Attach the instrument mounting bracket to the stainless steel hinge using the supplied 3/8" x 3/4" bolts, 3/8" flat washers, 3/8" lock washers, and 3/8" nuts.
- 5) Attach the instrument to the instrument

mounting bracket using the supplied 3/8" x 5/8" bolts, 3/8" flat washers, and 3/8" lock washers.

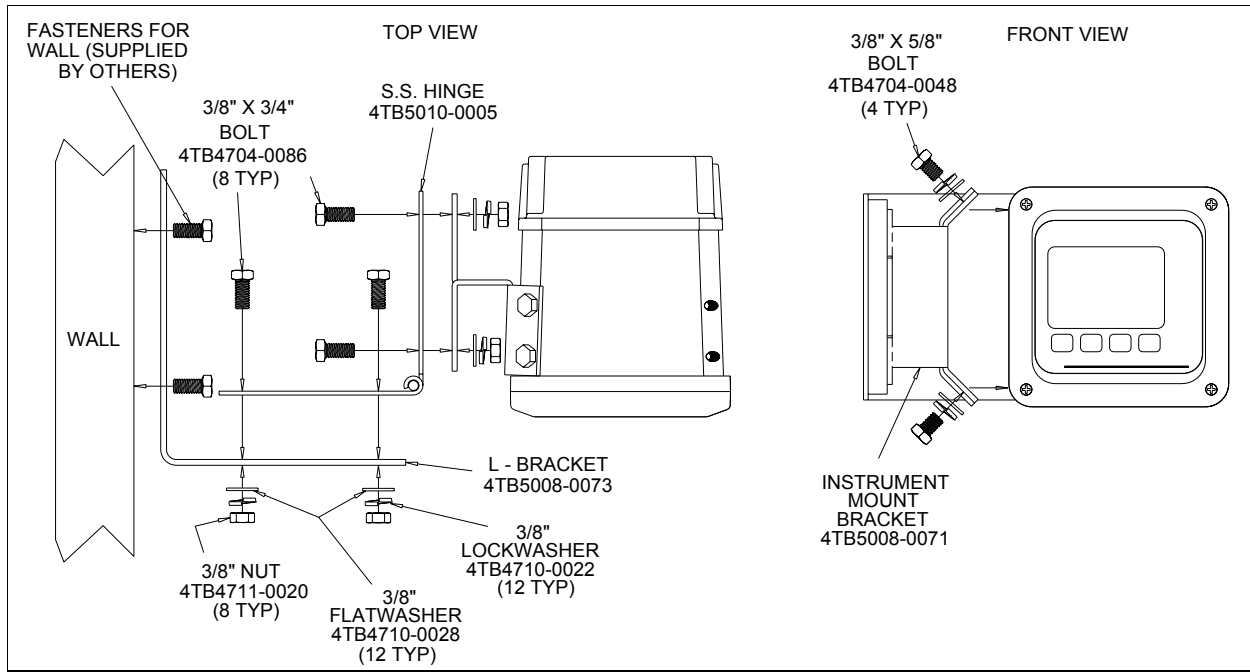
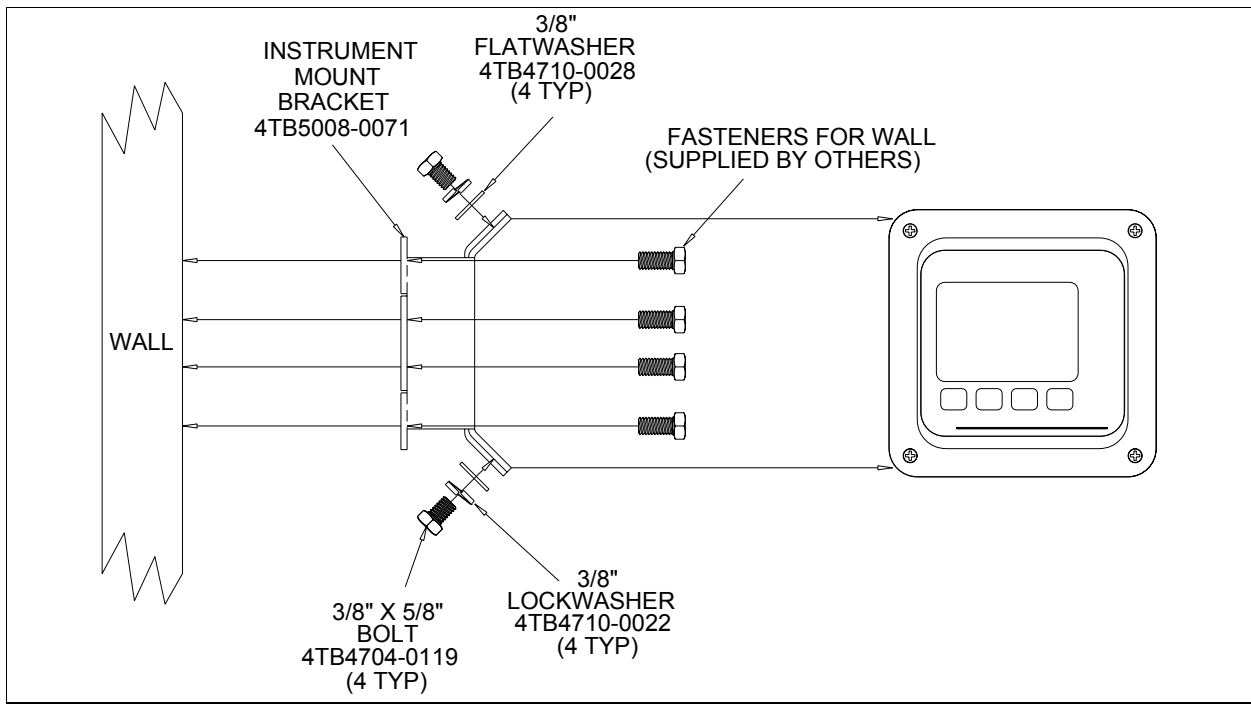

Figure 3-3. Hinge Mount Installation Diagram
Wall Mounting

The TB84PH Wall Mount Kit (p/n 4TB9515-0156) contains an instrument mounting bracket with associated hardware. Wall mounting accommodates installations where the analyzer can be positioned for a clear line of sight and free access to the rear terminations. These types of installation include supporting beams, flange brackets, and wall ends.

Using Figure 3-4 as a reference, mount the TB84PH analyzer as follows:

- 1) Select the desired location and orientation of the TB84PH analyzer.
- 2) Attach the instrument mount bracket to the selected location using the appropriate type of fastener based on the mounting surface material.
- 3) Attach the instrument to the instrument mounting bracket using the supplied 3/8" x 5/8" bolts, 3/8" flat washers, and 3/8" lock washers.



**Figure 3-4. Wall Mount Installation Diagram
Panel Mounting**

The TB84PH Panel Mount Kit (p/n 4TB9515-0123) contains four panel bracket assemblies and a panel gasket. The TB84PH enclosure conforms with DIN sizing and requires a 135.4 mm x 135.4 mm cut-out for panel mounting. The panel brackets accommodate a maximum panel thickness of 3/8".

Using Figure 3-5 as a reference, mount the TB84PH analyzer as follows:

- 1) Select the desired location of the TB84PH analyzer.

2) Cut a 135.4 mm x 135.4 mm hole with diagonal corners through the panel as shown in Figure 3-5.

3) Install the panel gasket onto the instrument.

4) Remove Rear Cover if necessary, and insert the instrument through the panel cut-out.

5) Attach the panel mounting bracket assembly to all four corners of the analyzer.

6) Tighten the adjustment screws on the panel mounting brackets until the analyzer seats against the panel. Note, do not over-tighten the adjustment screws or damage to the brackets and panel may result.

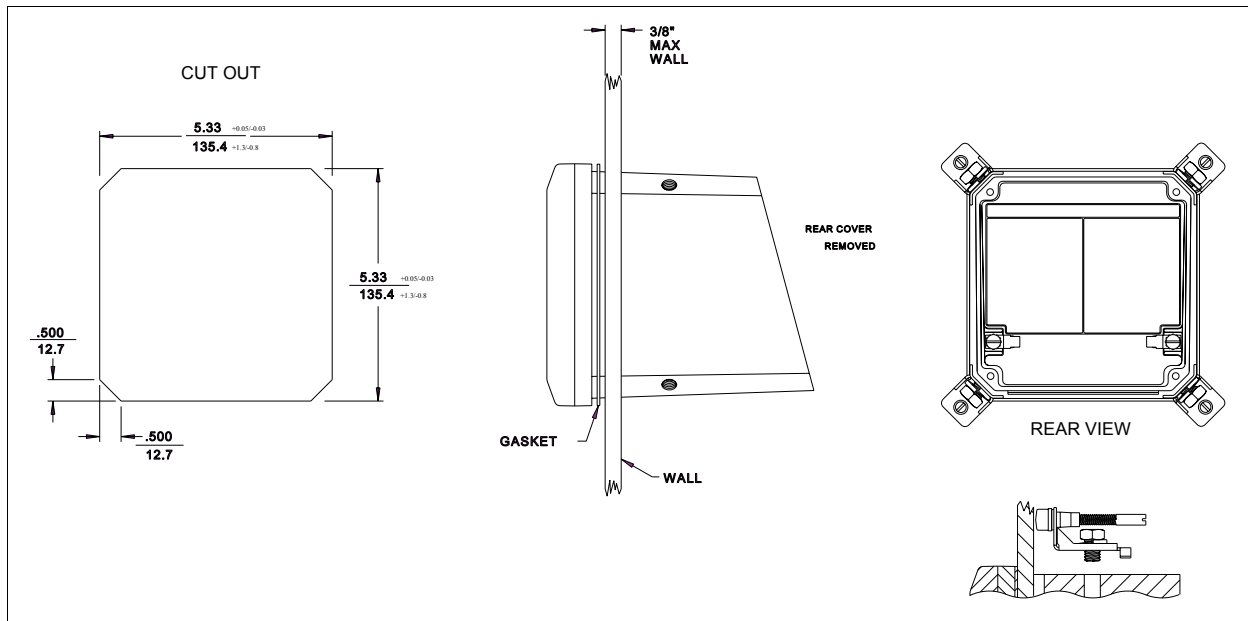

Figure 3-5. Panel Mount Installation Diagram

WIRING CONNECTIONS AND CABLING

CAUTION

To prevent possible signal degradation, separate metal conduit runs are recommended for the sensor, signal, and power wiring.

Under ideal conditions, the use of conduit and shielded wire may not be required. However, to avoid noise problems, power, signal, and output wiring should be enclosed in separate conduit. Just prior to entering the housing, rigid conduit should be terminated and a short length of flexible conduit should be installed to reduce any stress to the housing.

Note: To maintain a NEMA 4X/IP65 rating, use approved conduct connections or cord grips that have the same type of ratings.

Power and signal wiring must bear a suitable voltage rating, have a maximum temperature rating of 75°C (167°F), and must be in accordance with all NEC requirements or equivalent for the installation site. Use either a standard three-prong grounded flexible CSA certified line cord or equivalent for power supply connection or hard wire directly to the AC supply. If hard wiring the AC power supply, use stranded, 14 AWG copper conductor wire.

Signal wiring should not be run in the same conduit or open trays where power wiring for high amperage electrical equipment exists. Ensure the final installation of signal and power wiring prevents physical and/or electrical interfere.

Note: Use weatherproof connections for all wiring ports. Heyco RLTF ½" and LTF 9 cable grips are available through ABB Inc.. See Section 17, Support Services.

The TB84PH Advantage Series analyzer accepts wire sizes 12 to 24 AWG. Signal wiring should always be twisted, shielded pairs to ensure the best performance. Pin-style terminals are recommended for all connections and available as kits from the factory. See section 17, Support Services, for more information.

Power Wiring

WARNING

Disconnect the AC line cord or power lines from the operating branch circuit coming from the source before attempting electrical connections. Instruments powered by AC line voltage constitute a potential for personnel injury due to electric shock.

WARNING

Keep the enclosure and covers in place after completing the wiring procedures and during normal operation. Do not disconnect or connect wiring or remove or insert printed circuit boards unless power has been removed and the flammable atmosphere is known NOT to be present. These procedures are not considered normal operation. The enclosure prevents operator access to energized components and to those that can cause ignition capable arcs. Failure to follow this warning can lead to unsafe conditions that can injure personnel and damage equipment.

The TB84PH Advantage Series analyzer does not require pre-setting a jumper to accept different line-power voltages. Power connections are located in the back of the instrument housing. The terminal block label identifies all line power, output signal, and sensor connections.

Notes:

1. ABB recommends installing a power line switch for safety purposes and for providing power-up and power-down convenience when servicing the analyzer.

2. Do not power the system from a transformer that also powers large motor loads (over five horsepower) or any other type of equipment that generates line voltage surges, sags and excessive noise.

Using Figure 3-7 as a reference, make line power connections as follows:

1) Strip wire insulation back approximately 0.250" (seven millimeters) to ensure the bare wire will make good contact with the Insulated Pin Lug terminals and will not be exposed beyond the pin insulator.

2) Crimp Pin Lug terminals to wire using Panaduit CT 570 or equivalent.

3) Connect the specified line voltage to TB1-1 (Line - L1), the neutral to TB1-2 (Neutral - L2), and the ground to terminal TB1-3 (Chassis Ground).

Analog Output Signal Wiring

The terminal block label identifies the analog output connections. Terminal polarity is shown and must be observed to ensure proper operation. The maximum load resistance for the analog outputs is specified in Table 1-3, Specifications. The maximum load resistance must include all devices and wiring within the analog output current loop. See Figure 3-7 for a wiring diagram.

Using Figure 3-7 as a reference, make analog output connections as follows:

- 1) Strip wire insulation back approximately 0.250" (seven millimeters) to ensure the bare wire will make good contact with the Insulated Pin Lug terminals and will not be exposed beyond the pin insulator.
- 2) Crimp Pin Lug terminals to the wire using Panaduit CT 570 or equivalent.
- 3) Connect the wiring to the appropriate analog output terminals.

Relay Output Signal Wiring

The relay outputs are shipped from the factory in the default state of Normally Open. That is, the relay contacts will be open when the relay is not energized. To change the normal state of any of the three relay outputs, switches on the power supply PCB assembly must be moved to different positions.

Using Figure 3-6 as a reference, change the normal state of any relay output as follows:

- 1) Unscrew the four captive screws located at the four corners of the Front Bezel Assembly.
- 2) Lightly pull the Front Bezel Assembly from the Shell Assembly.
- 3) Identify the Power Supply PCB Assembly and relay state switches using Figure 3-6.
- 4) Move the switch position to the desired normal state (i.e., Normally Open or Normally Closed.)

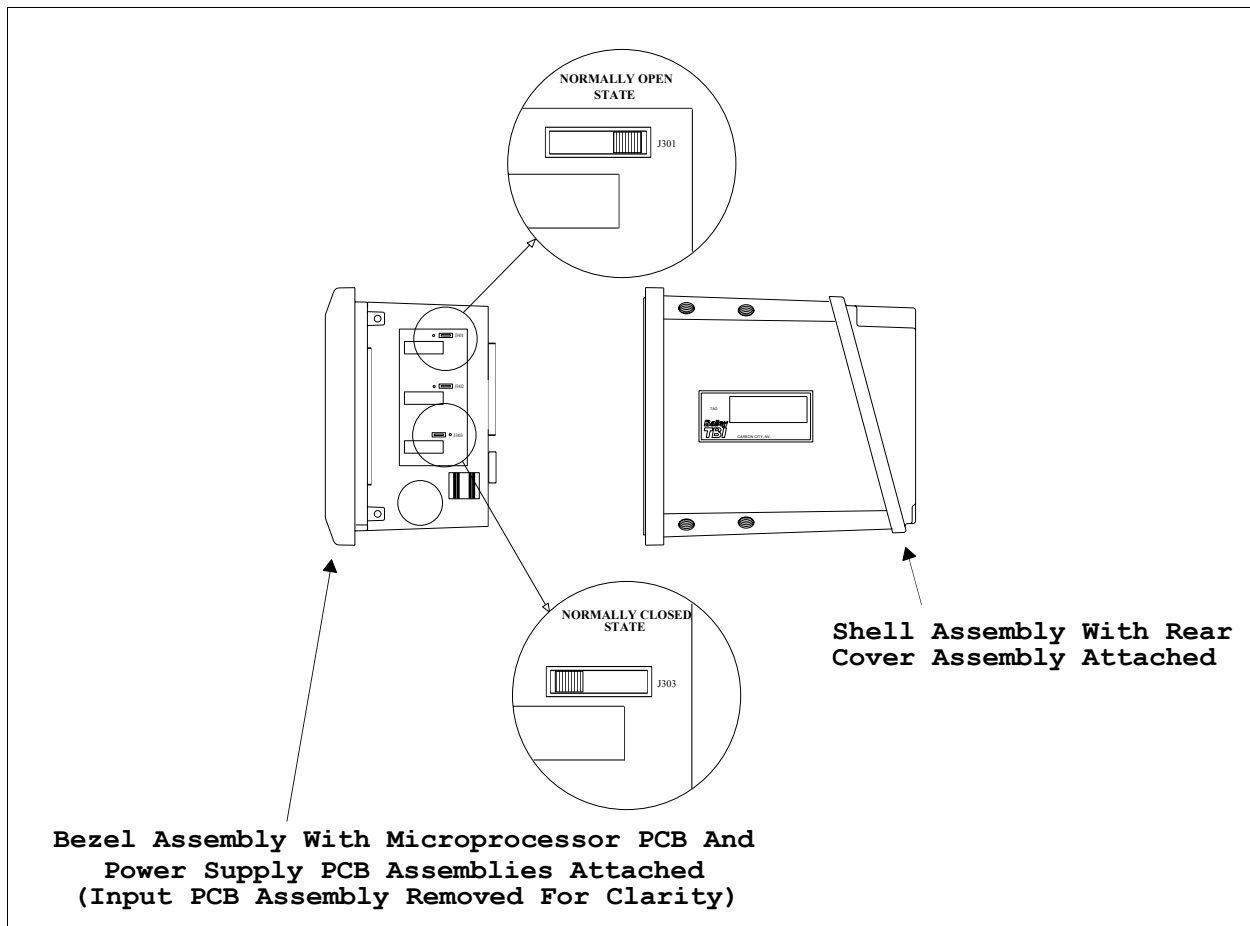

Figure 3-6. Normal State Relay Jumper Location.

Using Figure 3-7 as a reference, make relay output connections as follows:

- 1) Strip wire insulation back approximately 0.250" (seven millimeters) to ensure the bare wire will make good contact with the Insulated Pin Lug terminals and will not be exposed beyond the pin insulator.
- 2) Crimp Pin Lug terminals to the wire using Panaduit CT 570 or equivalent.
- 3) Connect the wiring to the appropriate relay output terminals.

Advantage Series (TBX5) Sensor Wiring

Instrument connections for the sensor wiring are located next to the signal connections. Sensor wiring should be run in shielded conduit, or similar, for protection from environmental influences. Do not allow the wires to become wet. The wiring should not lay on the ground or over any other equipment. Ensure cables are not abraded, pinched or bent during the installation process or during normal operation.

The sensor cable has seven leads with pin terminals that must be connected to the terminal block in the rear cavity of the TB84PH Advantage Series analyzer. The seven leads are color coded and have the following functions and connections:

Terminal Block Location	Sensor Color Code	Function
TB2-1	Blue	Sense
TB2-2	Yellow	Guard
TB2-3	Black	Reference
TB2-4	Green	Solution Ground
TB2-5	Red	RTD
TB2-6	White	RTD
TB2-7	Hvy Grn	Shield
TB2-8	N/A	N/A

Remove the protective insulator from the Black lead before installing it into the analyzer's terminal block. The insulator has been provided to prevent shorting of the sensor half-cell. Shorting of this conductor will

permanently damage the sensor.

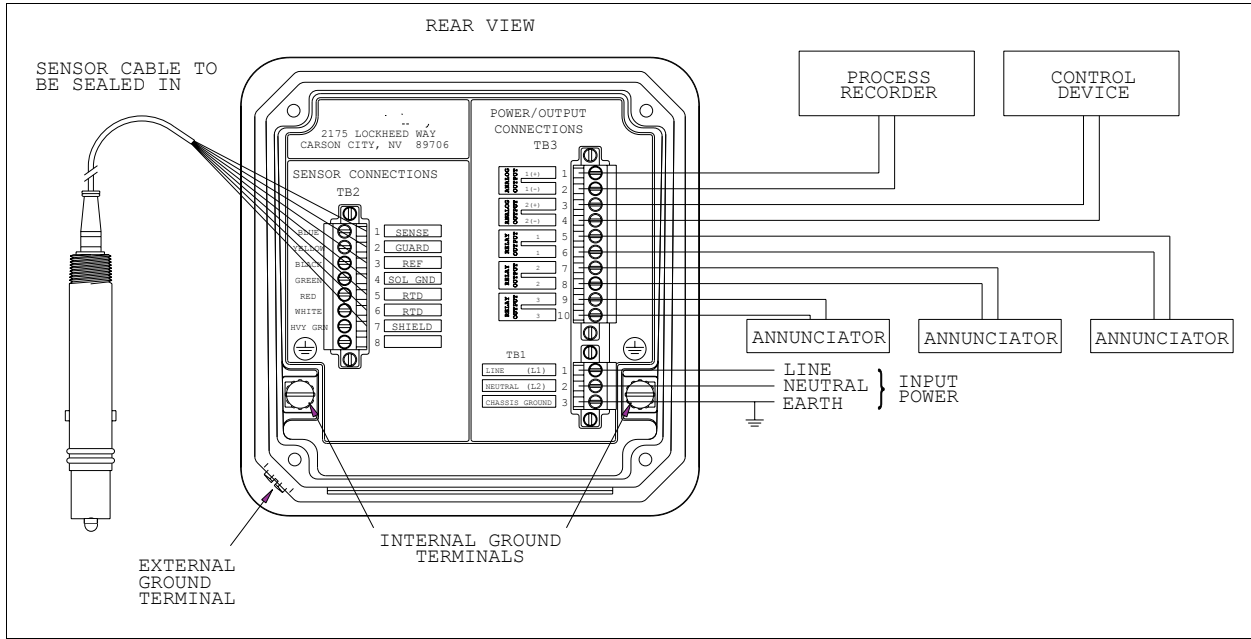

Figure 3-7. Instrument Wiring Diagram.
Non-Advantage Series (TB5) Sensor Wiring

For standard and Next Step ABB sensors (i.e., TB5), a pin terminal option is available for installation to a TB84PH Advantage Series analyzer. Though this cable option is recommended when using a non-Advantage Series sensor, stocking preferences may tend towards the use of one common sensor. If this sensor type requires a BNC connector to mate with existing instrumentation, a BNC Adapter (included with all TB84PH Advantage Series analyzers) provides such a connection.

When using the pin terminal sensor cable option (i.e., the T[][] nomenclature option where [][] represents the cable length), connect color coded leads to the analyzer's terminal block as follows:

Terminal Block Location	Sensor Color Code	Function
TB2-1	Blue	Sense
TB2-2	N/A	Guard
TB2-3	Black	Reference
TB2-4	N/A	Solution Ground
TB2-5	Red (If Applicable)*	RTD

TB2-6	White (If Applicable)*	RTD
TB2-7	N/A	Shield
TB2-8	N/A	N/A

* Note: Red and White conductors will only be present if a temperature compensator is being using.

Since pH/ORP/pION sensor cables generally contain a low-noise conductive layer within the coax, complete removal of this layer is extremely important to ensure correct sensor operation. Additionally, most conductors within the sensor cable are small and are not recommended to be used directly in the TB84PH Advantage Series' terminal blocks; therefore, the BNC Adapter (p/n 4TB9515-0164 or 4TB9515-0166) is recommended over removing the BNC and stripping back each of the individual conductors.

Using Figure 3-8 as a reference, install the BNC Adapter and connect the BNC-type sensor as follows:

- 1) Remove the earth ground screw and hardware located below the SENSOR CONNECTIONS terminal block.
- 2) Slide the earth ground screw (and remaining hardware if desired) through the screw hole on the BNC Adapter so that the adapter's leads and female BNC are pointing upwards.
- 3) Mount the BNC Adapter to the available threaded earth ground hole.

4) Connect the BNC Adapter pin terminals to the corresponding SENSOR CONNECTIONS terminal block locations via the conductor color coding.

Note: If the sensor does not have a female connector for the Temperature Compensator (TC), connect the leads from the sensor directly to the terminal block locations TB2-5 and TB2-6 (i.e., Red and White). For sensors without TC, leave TB2-5 and TB2-6 open.

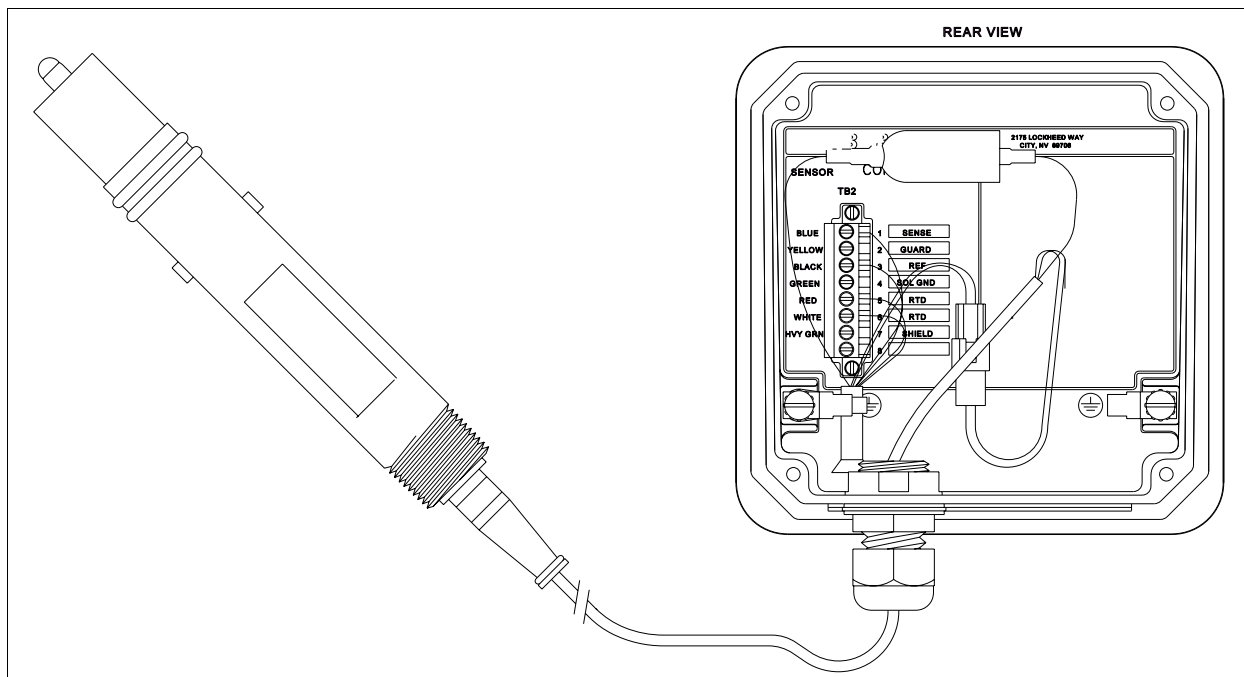

Figure 3-8. BNC Adapter Installation and Wiring Diagram

5) Connect the male BNC from the sensor to the female BNC from the BNC Adapter and the female TC connector from the sensor to the male TC connector from the BNC Adapter.

6) Slide the protective boot over the BNC connection to prevent any possible shorting to earth surfaces.

Note, if the BNC surface is in contact with a earth ground surface, a ground loop through the sensor may occur and could result in poor sensor performance and shortened sensor life.

GROUNDING

The customer and/or wiring contractor is responsible to ensure that the analyzer, associated control or test equipment, and all exposed conductive materials are properly grounded. Grounding procedures should be in accordance with local regulations such as the National Electrical Code (NEC), Canadian Electrical Code (CEC), or equivalent. Equipment installation must not pose a hazard, including under fault conditions, to operation and service personnel.

Signal wiring should be grounded at any one point in the signal loop or may be ungrounded (floating) if electrical noise is minimal.

The analyzer enclosure must be grounded to an earth ground having less than 0.2 ohms of resistance. Internal and external earth ground terminals are provided and shown in Figure 3-7.

Notes:

1. Because of the prevailing differences in soil conditions and in acceptable grounding practices throughout the world, the scope of this product instruction does not intended to be used to describe grounding electrode systems. The customer is responsible to ensure a grounding electrode system is acceptable to the local building and wiring codes.
2. Using the structural metal frame of a building as the required equipment grounding conductor for the analyzer is not advised.

OTHER EQUIPMENT INTERFACE

The TB84PH Advantage Series analyzer provides two isolated current outputs that are proportional to the process variable(s). Since the analyzer output is isolated, each current loop may have a maximum of one non-isolated device within its circuit. The maximum load on the each current loop must not exceed the specification listed in Table 3-1, Specifications.

INSTRUMENT ROTATION

The TB84PH Advantage Series analyzer has four pairs of threaded mounting holes in enclosure. Since these holes are located at the corners of the instrument, the TB84PH Advantage Series analyzer can be positioned in any of the four positions as demonstrated in Figure 3-9.

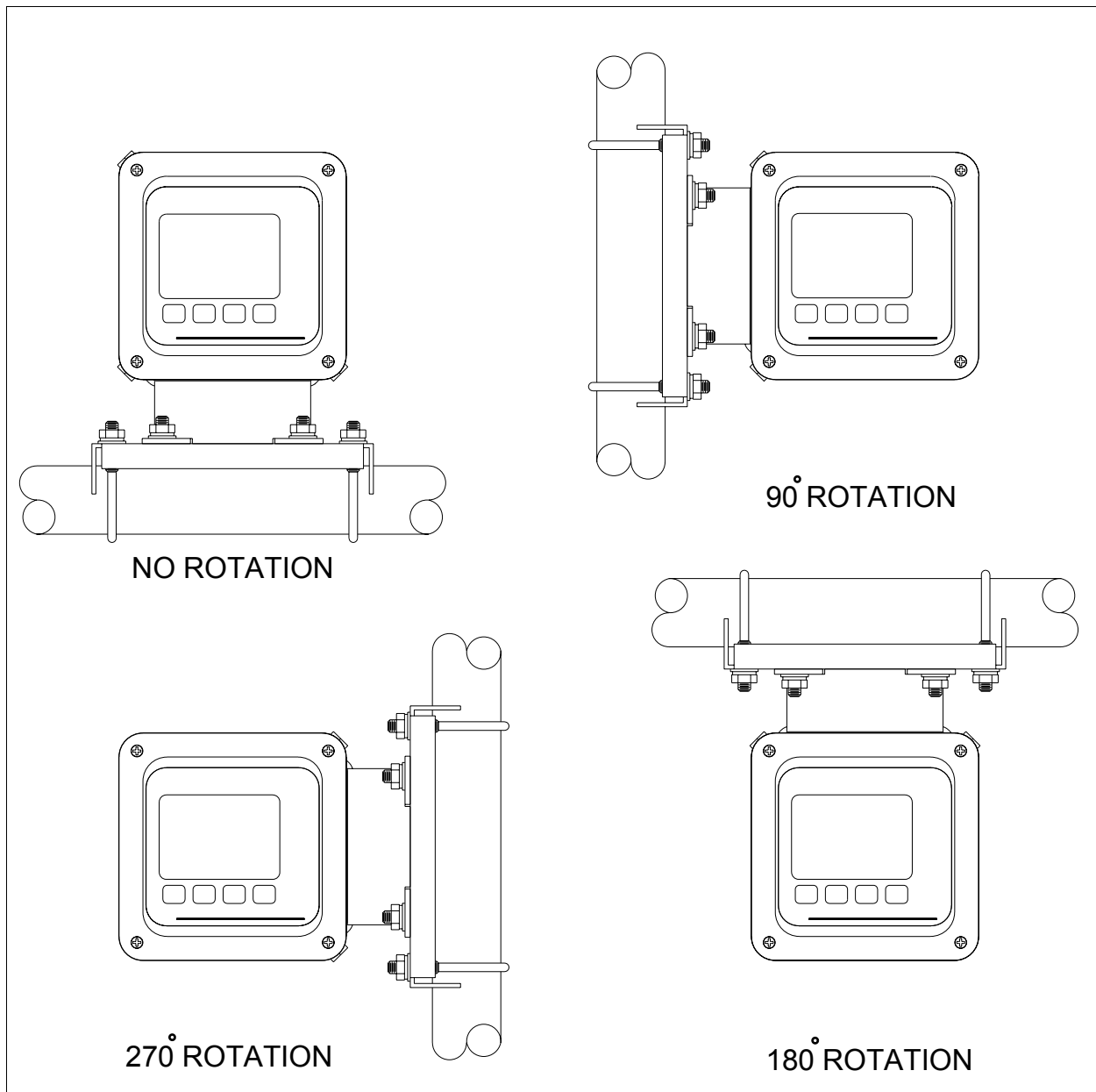

Figure 3-9. Mounting Rotation (Pipe Mount Shown)

SECTION 4 - OPERATING PROCEDURES

INTRODUCTION

The TB84PH Advantage Series analyzer has seven main operating modes: Measure, Calibration, Output/Hold, Configuration, Security, secondary Display, and Setpoint/Tune. Within each mode, several programming states containing functions specific to the related mode are available.

The TB84PH Advantage Series analyzer is equipped with a built-in user interface through which all analyzer functions are programmed or monitored. In order to maximize the viewing area and minimize the space needed for the keypad, the interface is based on a custom LCD that contains a group of two or more icons for each button on the four button keypad. Each icon represent a key function that is energized when that function is required (patent-pending).

Two display regions in the custom LCD handle the majority of instrument functions. These regions include a primary display area for the process variable (e.g., pH) and a secondary display area for programming text prompts or auxiliary information.

In addition to the user-friendly interface, the TB84PH Advantage Series analyzer is equipped with a group of icons that alerts the user to an existing FAULT condition, diagnostic SPIKE output, output HOLD condition, or activated RELAY. These icons are located at the top of the LCD and are only energized when the specified condition is detected. FAULT conditions are shown in the secondary display using the FAULT INFO key when the instrument is in the Measure Mode of Operation.

OPERATOR INTERFACE CONTROLS REVIEW

Liquid Crystal Display (LCD)

The LCD contains nine regions that provide the user with information on the process variable, engineering units, mode of operation, output hold condition, fault indication, relay activation, secondary variable, and key function assignments. Figure 4-1 shows a fully energized LCD, Smart Keys, and mode text.

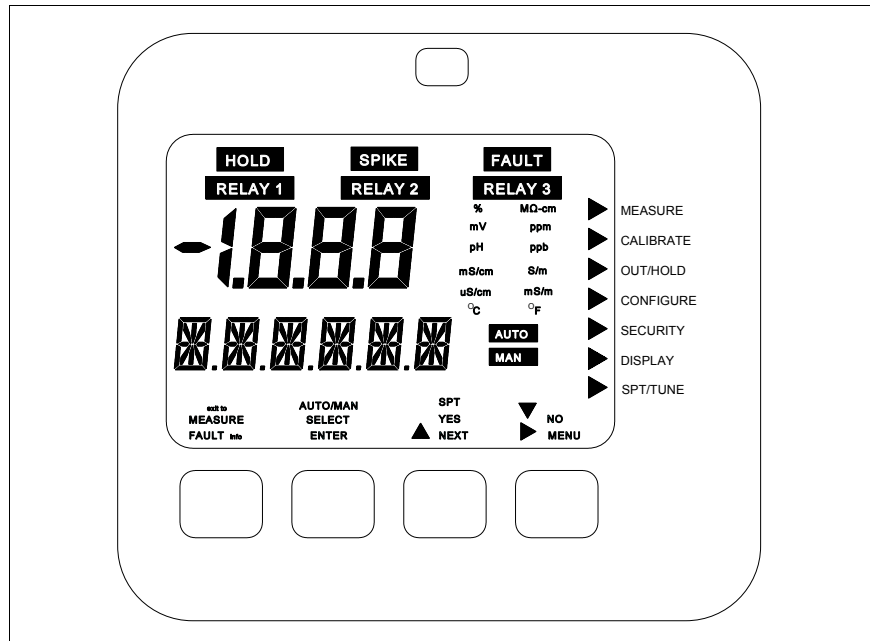

Figure 4-1. Fully Energized Display And Supporting Information.

The top set of icons informs the user of an abnormal operating condition such as an output HOLD condition, FAULT condition, diagnostic SPIKE output, or RELAY activation. These icons are only energized when such a condition is detected and are active in all modes of operation.

For the mode of operation indicators (shown as right arrows grouped next to the mode text), only one indicator will be lit and will indicate the current mode of operation of the analyzer. As a user moves from one mode to the next, the appropriate indicator will energize. The mode of operation indicators are active in all modes of operation.

The process variable is displayed in the three and one-half digit, seven segment region.

This display region is supported by the engineering unit region. These regions are active in all modes of operation; however, in some programming states, the process variable region will be used for data entry and the engineering unit region will reflect the data unit.

The secondary variable is displayed in the six-character, fourteen segment region. This display region is used for displaying secondary information and fault information in the Measure Mode of Operation and textual prompting in all other modes of operation. Due to the limited number of characters for this display region, much of the prompting takes the form of text abbreviations (see Appendix B for a list of abbreviations.) This region is active in all modes of operation.

The Smart Key assignments are grouped into four sets of icons, each group directly positioned above one of the four keys. These icons are textual representations of the function for the associated key. Only one assignment will be energized per Smart Key at any given time.

Multi-Function Smart Keys

A five-button, tactile keypad is located on the front panel of the instrument. Four of the gray buttons are embossed to easily show their location. A fifth, hidden button located at the top of the NT in the text ADVANTAGE has been included to provide access to functions that are infrequently used.

The four embossed keys are called Smart Keys since their functions are dependent on the mode and/or state of the instrument. Since these four keys do not have a preassigned function, icons are energized over the key to indicate its function. If a Smart Key does not have an icon energized above its location, this Smart Key does not have a function and will not initiate an action when pressed. Using this Smart Key method, a smaller number of keys can be used without complicating instrument functionality.

Table 4-1. Smart Key Definition of Operation

Icon	Smart Key Function
exit to MEASURE	Escapes back to the Measure Mode from all other modes or programming states of operation. This function is not available in the Measure Mode.
FAULT info	Accesses information on diagnostic problem or error conditions. Displays this information as a short text string and code. This function is only available in the Measure Mode.
AUTO/MAN	Not used at this time.
SELECT	Selects the mode or programming state of operation shown in the secondary display region.
ENTER	Stores configured items and data into permanent memory.
SPT	A shortcut key to the Setpoint/Tune Mode of Operation. This function is only active in the Measure Mode.
YES	Affirms the action that is about to take place.
>	Increments numeric values or moves through a series of parameters.
NEXT	Increments through a series of programming states.
?	Decrements numeric values or moves through a series of parameters.
NO	Denies the action that is about to take place.
<	Moves the flashing data entry value one space to the right.
MENU	Increments through the modes of operation.

For each operating mode and/or state, pressing the Smart Key initiates the displayed function of that Smart Key. For example, the function NEXT allows a user to cycle through a series of programming states for a given mode of operation. The function SELECT enables the user to enter into the displayed mode or state of operation. Using this method, the TB84PH Advantage Series analyzer guides the user through the necessary steps use to program or monitor any given function. A general description of each Smart Key function is

given in Table 4-1.

MODES OF OPERATION

The Measure Mode is the normal operating mode of the TB84PH Advantage Series analyzer and is the default mode upon power-up. The Measure Mode is the starting point for entry into other modes of operation. Each mode contains a unique set of analyzer functions or states. These modes and their related functions are listed in Table 4-2.

Table 4-2. Mode of Operation Definitions

MODE	FUNCTION
Measure	Used to display the process and secondary variables - the normal operating mode for the analyzer.
Calibrate	Used to calibrate input and analog output functions.
Out/Hold	Used for on-line tuning of analog output parameters or to manually set the analyzer analog outputs, for example, during maintenance.
Configure	Used to configure analyzer functions such as temperature compensation, temperature sensor type, and measurement electrode type.
Security	Used to enter password protection for the Calibrate, Out/Hold, Configure, and Setpoint/Tune Modes of Operation.
Display	Used to select the variable that will be shown in the secondary display region when the analyzer is in the Measure Mode of Operation.
SPT/Tune	Used for on-line tuning of relay output parameters.

HOLD ICON

The Hold icon energizes when a hold condition is active. Outputs can be either manually or automatically held.

Manual activation is accessible in the Output/Hold Mode of Operation. In this mode, the Hold State permits the output to be held at the current level and/or state or at a level and/or state manually set by the user.

Automatic activation occurs during a Two-Point Process Variable Calibration and Cleaner activation. For the Two-Point Process Variable Calibration, the analyzer will automatically hold all outputs at the current levels and states. Upon completing the two-point calibration, the TB84PH Advantage Series analyzer will query the user to either release or maintain the hold condition.

For a relay output configured as a Cleaner, a user has the option to enable an automatic hold condition using the levels and states capture directly before initiating the cleaning operation. The hold condition only occurs during the relay on and recovery times and can be separately set for the analog and relay outputs. If desired, the relay outputs can be disabled instead of held during a cleaning cycle.

FAULT ICON

The Fault icon energizes when a fault condition has been detected by the TB84PH Advantage Series analyzer. Fault conditions include all problem and error detection as outlined in Section 13, Diagnostics.

SPIKE ICON

The Spike Output function modulates Analog Output One from the normal level representative of the process variable to a value configured as a set percentage of output current. When the TB84PH Advantage Series analyzer has detected a fault condition and the Spike Output function has been enabled, Analog Output One will begin to modulate and the Spike icon will energize. For more information on Spike Output and Fault conditions, see Section 13, Diagnostics.

RELAY ICONS

The Relay icons are composed of three individual icons. Each icon represents the specified relay (i.e., Relay One, Relay Two, and Relay Three.) When a relay change state from its normal state to an energize state, the corresponding Relay icon also energizes. Since the normal state of each relay can be set by a switch, the relay icon will only inform the user of a state change and not whether the relay has closed or opened.

SECTION 5 - MEASURE MODE

INTRODUCTION

The Measure Mode is the normal operating mode of the analyzer and is the active mode upon analyzer power-up. In this mode, the process variable, output hold state, fault condition state, spike output state, relay output states, and secondary display information are displayed. From the Measure Mode, other modes of operation and fault information can be accessed.

BOREDOM SWITCH

When a user enters an operating mode or state and does not return to the Measure Mode as the final step, the TB84PH Advantage Series analyzer automatically returns to the Measure Mode of Operation after 20 minutes of unattended use. This feature ensures the analyzer will always be returned to its normal mode of operation.

PRIMARY DISPLAY

The primary display shows the process variable. The value of this variable is dependent on the configured analyzer, temperature compensation type, temperature value, sensor output, and damping value. The engineering units for the process variable are dependent only on the configured analyzer. Table 5-1 lists the analyzer types and corresponding engineering units.

Table 5-1. Engineering Unit And Analyzer Relationship

ANALYZER TYPE	ENGINEERING UNIT
pH	C pH
ORP	C mV (millivolts)
pION	C mV (millivolts)
ION CON (pION Concentration)	C ppm (parts per million)
	C ppb (parts per billion)
	C % (percent)
	C User Defined

SECONDARY DISPLAY

The secondary display has the ability to show a large variety of information. Since the display area only has six characters, only one item can be shown at any given time.

Typically, this region will be used for displaying the process temperature in degrees Celsius; however, it can be changed to display the process temperature in degrees Fahrenheit, output current in milliamperes (i.e., mA) for each analog output (shown separately), reference impedance in kohms, sensor output in millivolts (i.e., mV), and firmware revision. See Section 10, Secondary Display, for more information.

FAULT INFORMATION Smart Key

Fault information can only be accessed from the Measure Mode of Operation and is interrogated using the FAULT Info Smart Key. A fault condition causes the FAULT icon to blink and the FAULT Info Smart Key to appear. These indicators will be energized as long as the fault condition is present.

When pressing the FAULT Info Smart Key, the first fault condition will be shown in the secondary display. A short text string followed by the fault code will be sequentially shown. Depressing the FAULT Info Smart Key progressively moves from one fault to the next until all faults have been shown. Once all faults have been interrogated, the FAULT icon will no longer blink and remains energized until all fault conditions have been removed. If a new fault condition is detected, the FAULT icon will begin to blink to inform the user of the newly detected condition. For more information on fault conditions and codes, see Section 13, Diagnostics.

SPT Smart Key

The SPT or Setpoint Smart Key provides a short-cut directly to the SPT/TUNE Mode of Operation. This short-cut provides quick access to tunable relay parameters.

MENU Smart Key

The MENU Smart Key provides access to all other modes of operation. By pressing the MENU Smart Key, the analyzer moves from one mode of operation to the next. Visual feedback is provided in two manners: the mode indication arrow moves to the next mode of operation (e.g., Calibrate) and the secondary display shows the text string representative of that mode (e.g., CALIBR). Access into the

displayed mode of operation is achieved by using the SELECT Smart Key. An escape function to the Measure Mode of Operation is provided using the Exit to MEASURE Smart Key.

As seen by the detailed screen flow diagram shown in Figure 5-1, pressing the MENU Smart Key when in the Measure Mode moves the user to the Calibrate Mode. Once in the Calibrate Mode, pressing the Exit to MEASURE Smart Key returns the analyzer back to the Measure Mode, pressing the SELECT Smart Key moves the analyzer into the Calibrate States of Operation, and pressing the MENU Smart Key moves the analyzer to the Output/Hold Mode of Operation. Use Figure 5-1 to identify the Smart Key assignments and the resulting action.

Since each mode of operation contains many operation states used to set or tune the TB84PH Advantage Series analyzer functions, the following sections of this product instruction manual contain detailed descriptions of each mode of operation. Screen flow diagrams showing the programming text prompts, Smart Key assignment, and the resulting action for each Smart Key are also included. Refer to Appendix B for programming text string definitions and a programming function tree showing the relationship of all modes and states of operation.

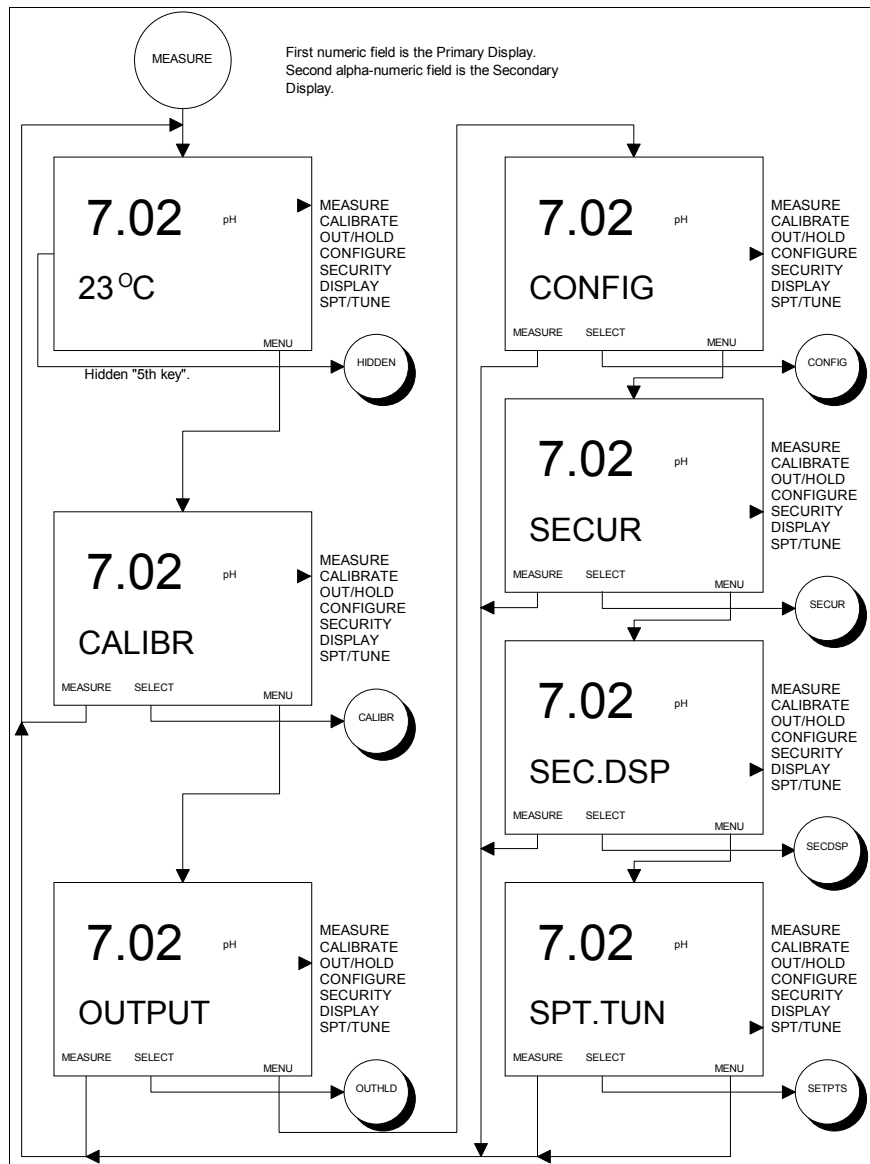

Figure 5-1. Screen Flow Diagram For Mode of Operation.

SECTION 6 - CALIBRATE MODE

INTRODUCTION

The Calibrate Mode of Operation provides the ability to calibrate the sensor input, temperature input, and analyzer outputs. These functions (i.e., Calibrate States of Operation) include process variable, temperature, edit, reset, and output calibration.

CALIBRATE STATES OF OPERATION

The Calibrate Mode consists of six states of operation. Table 6-1 describes the function of each state of operation.

Table 6-1. Calibrate States

State	Function
PH.CAL ORP.CAL ION.CAL	Used to calibrate the input from the process sensor using a one-point offset or two-point offset/efficiency calibration.
TMP.CAL	Used to calibrate the input from the temperature sensor using a one-point smart calibration that adjusts the offset, slope, or both based on sensor calibration history.
EDT.CAL	Used to manually adjust the process sensor offset and efficiency and temperature sensor offset and slope values.
RST.CAL	Used to restore calibration values for the process variable and temperature back to factory settings.
A01.CAL	Used to calibrate Analog Output One. Requires an external validation device.
A02.CAL	Used to calibrate Analog Output Two. Requires an external validation device.

When in the Calibrate Mode, the NEXT Smart Key provides access to all Calibrate States. Pressing the NEXT Smart Key sequentially moves the user through each Calibrate State. This cycle repeats until a Calibrate State is selected using the SELECT Smart Key, or the

escape function is chosen using the Exit To MEASURE Smart Key. Use Figure 6-1 to identify the Smart Key assignments and the resulting action.

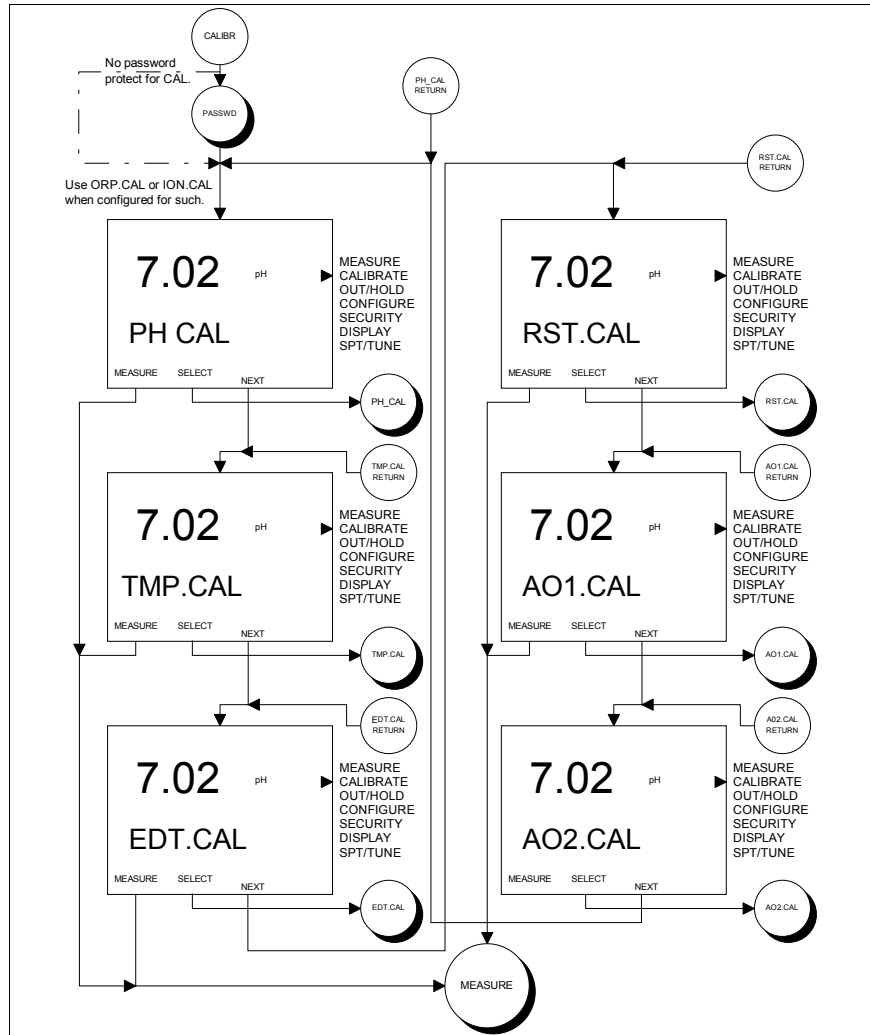

Figure 6-1. Screen Flow Diagram For Calibrate States of Operation.

The following subsections contain detailed descriptions of each Calibrate State of Operation.

Process Sensor Calibrate State

The Process Sensor Calibrate State contains two calibration procedures:

- 1) 1PT.CAL (One-Point Calibration) and
- 2) 2PT.CAL (Two-Point Calibration).

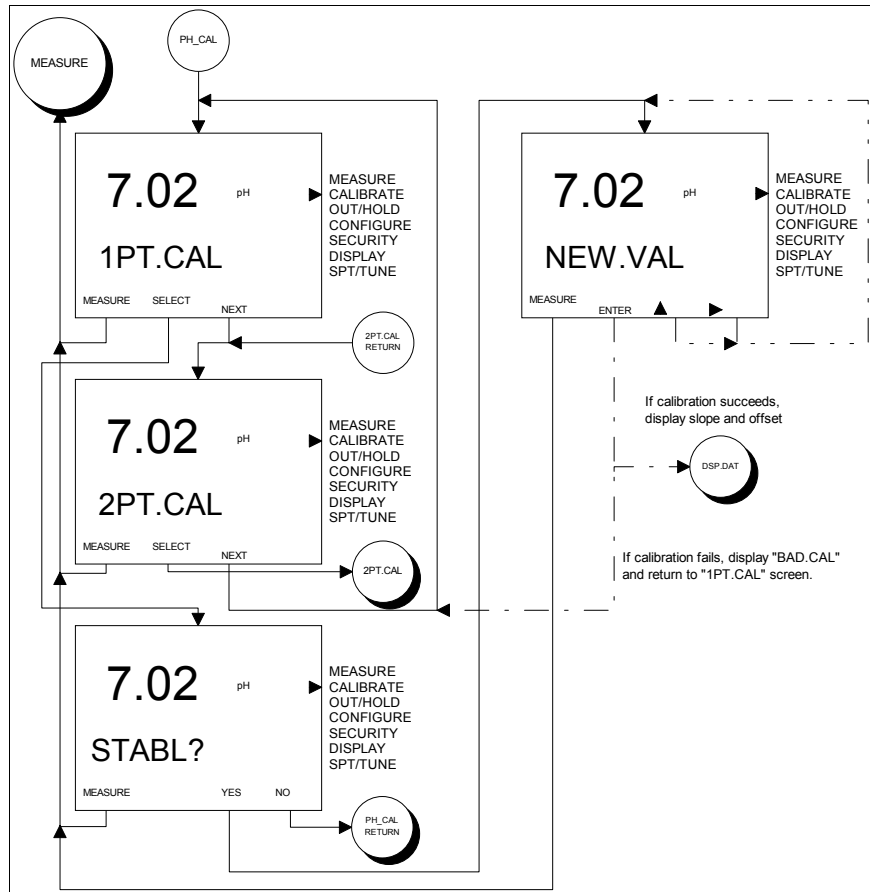

Figure 6-2. Screen Flow Diagram For Process Sensor Calibrate State of Operation.

As with the other states of operation, the two calibration procedures can be toggled by using the NEXT Smart Key, selected by using the SELECT Smart Key, and escaped by using the Exit To MEASURE Smart Key.

Use Figure 6-2 to identify the Smart Key assignments and the resulting action.

One-Point Calibrate State

Due to variations in ionic strength between the sensor reference and process liquid, improved accuracy can be realized by conducting a one-point calibration with the sensor in its final location. Typically, the analyzer is verified against an external validation device using a grab sample. The One-Point Calibrate State conducts an offset adjustment on the sensor input.

Conduct a One-Point Calibration using Figure 6-2 as a reference and the following procedure:

- 1) Select the 1PT.CAL in the Process Sensor Calibrate State of Operation using the SELECT Key.
- 2) Verify the process variable value using an external instrument having the same type of temperature compensation and a grab sample.
- 3) Confirm the TB84PH Advantage Series analyzer displayed reading is STABL? (i.e., stable) using either the YES or NO Key. If the NO Key is pressed, the analyzer will return to the Process Sensor Calibrate State. For an unstable condition, conduct one or more of the following steps:
 - a) Wait until process liquid composition stabilizes,
 - b) Check to see if the TB84 Advantage Series analyzer has detected a Fault condition by looking for the Fault icon on the LCD. Interrogate the fault by escaping to the Measure Mode using the Exit to MEASURE Key and the FAULT Info Key in that order.
 - c) See Section 14, Troubleshooting.

-
- 4) If the reading was stable, enter the NEW VAL (i.e., new process variable) that reflects the difference between the grab sample value and the indicated value when the grab sample was taken (i.e., Current TB84PH Indication + [Grab Sample Value - TB84PH Indication at the time the grab sample was taken]). Use the ▲ Key to increment the digit value and the ► Key to move to the next digit. Press the ENTER Key to enter the new value.

Invalid calibration values will generate the text string BAD.CAL, and the calibration value will not be accepted. If the new value is valid, the Efficiency (i.e., slope value shown as a percentage of theoretical) will be shown. Pressing the NEXT Smart Key displays the Offset value. At this point, the user can return to the Process Sensor Calibrate State by pressing the NEXT Smart Key or to the Measure Mode by pressing the Exit To MEASURE Smart Key.

Note: If a Hold condition is present, the TB84PH Advantage Series analyzer inquires if this condition should be released.

For more information on sensor calibration techniques and troubleshooting, refer to TP90-2.

Two-Point Calibrate State

The Two-Point Calibrate State conducts offset and slope adjustments on the sensor input to determine its response characteristics. This calibration is typically conducted before installation into its final location and periodically during the life of the sensor when the response of the sensor begins to decrease. This calibration procedure uses buffers or standards depending on the type of sensor (e.g., pH versus pION, respectively).

When conducting a Two-Point Calibration, the TB84PH Advantage Series analyzer initiates an automatic Hold All condition. The Hold icon will begin to flash, and the Hold All condition will remain active until the calibration is complete.

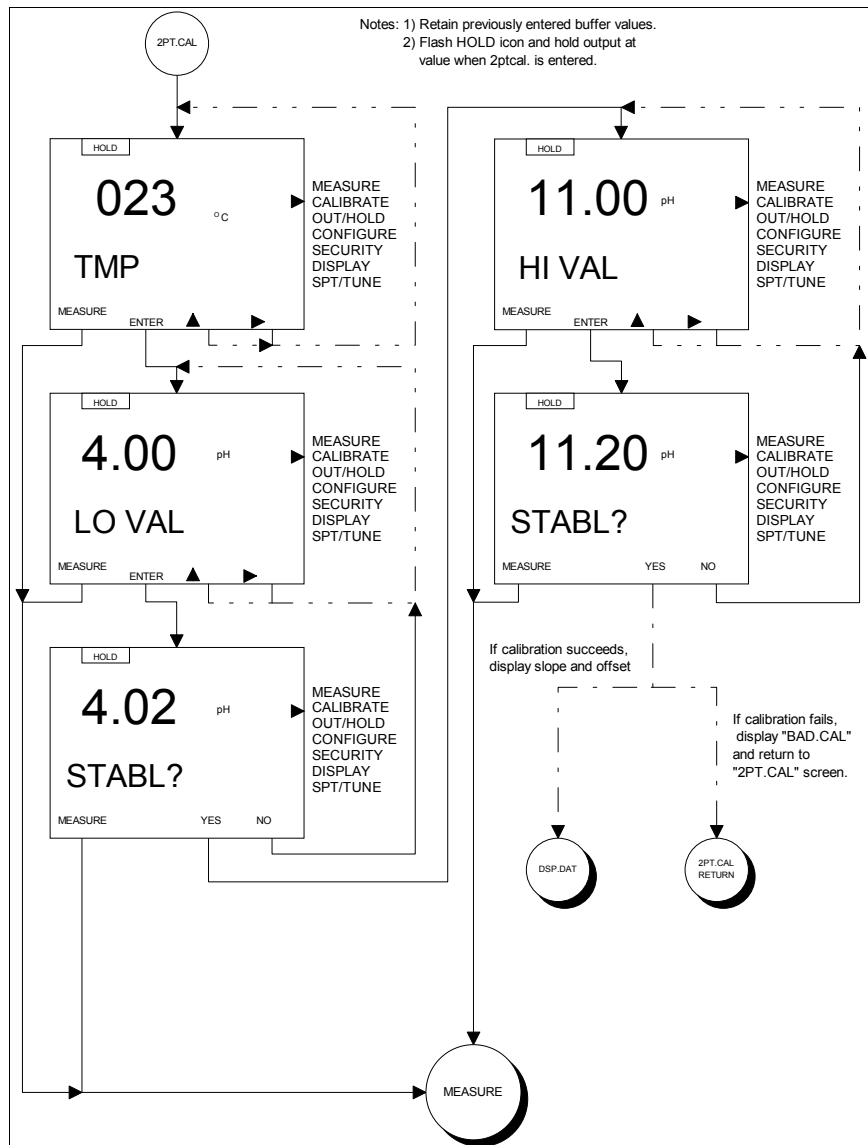

Figure 6-3. Screen Flow Diagram For Two-Point Process Calibration.

Conduct a Two-Point Calibration using Figure 6-3 as a reference and the following procedure:

- 1) Prepare the Buffer Solutions.
- 2) Select the 2PT.CAL in the Process Sensor Calibrate State of Operation using the SELECT Key.

-
- 3) Remove the sensor from the process piping if required.
 - 4) Enter the TMP^{°C} (i.e., temperature in degrees Celsius) of the buffer or standard solution using the ▲ Key to increment the blinking digit and the ► Key to move to the next digit. Press the ENTER Key to enter the new value.
 - 5) Enter the LO VAL (i.e., low buffer or standard value) using the ▲ Key to increment the blinking digit and the ► Key to move to the next digit. Press the ENTER Key to enter the new value.
 - 6) Place the sensor in the low buffer or standard solution and stir the solution with the sensor in a slow, circular motion.
 - 7) Once the reading is stable, confirm by using either the YES or NO Key at the STABL? (i.e., stable) text prompt.
 - 8) Enter the HI VAL (i.e., high buffer or standard value) using the ▲ Key to increment the blinking digit and the ► Key to move to the next digit. Press the ENTER Key to enter the new value.
 - 9) Remove the sensor from the low buffer or standard solution, rinse the sensor, and place the sensor in the high buffer or standard solution and stir the solution with the sensor in a slow, circular motion.
 - 10) Once the reading is stable, confirm by using the YES or NO Key at the STABL? (i.e., stable) text prompt.

Invalid calibration values will generate the text string BAD.CAL, and the calibration value will not be accepted. If the values are valid, the Efficiency (i.e., slope value shown as a percentage of theoretical) will be shown. Pressing the NEXT Smart Key displays the Offset value. At this point, the user can return to the Process Sensor Calibrate State by pressing the NEXT Smart Key or to the Measure Mode by pressing the Exit To MEASURE Smart Key.

Note: If a Hold condition is present, the TB84PH Advantage Series analyzer inquires if this condition should be released.

For more information on sensor calibration techniques and troubleshooting, refer to TP90-2.

Temperature Calibrate State

The Temperature Calibrate State is a smart calibration routine that allows for both single- and dual-point calibration. By calibrating the temperature at two points which are at least 20°C apart, the TB84PH Advantage Series analyzer automatically adjusts the offset and/or slope. Since this routine only uses the most recent calibration data, calibrations can be conducted throughout the sensor's life to ensure accurate measurement of the temperature sensing device. If an incorrect calibration has been entered, the Reset Calibrate State can restore the calibration to factory settings. See Reset Calibrate State in this section.

Note: The Reset Calibrate State will reset all calibration values including the process sensor; therefore, the process sensor will require calibration after performing the Reset Calibration procedure.

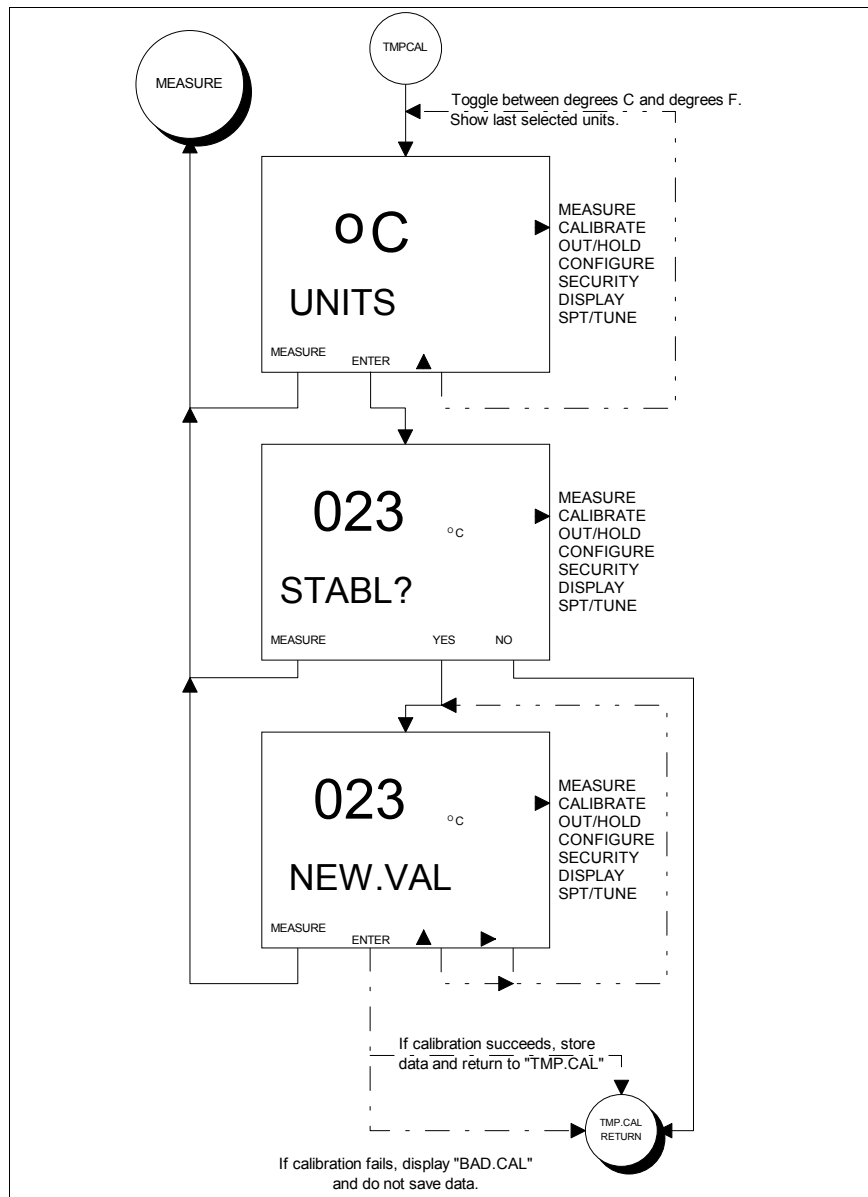

Figure 6-4. Screen Flow Diagram For Temperature Calibrate State of Operation.

Conduct a Temperature Calibration using Figure 6-3 and the following procedure:

- 1) Before installing the sensor into its final installed location, allow the sensor to reach ambient temperature.
- 2) Select the Temperature Calibrate State of Operation using the SELECT Key.

-
- 3) Set the engineering unit by pressing the ▲ Key to toggle the unit between °C (i.e., degrees Celsius) or °F (i.e., degrees Fahrenheit), and press the ENTER Key to use the displayed engineering unit.
 - 4) Confirm the displayed reading is STABL? (i.e., stable) using either the YES or NO Key. If the NO Key is pressed, the TB84PH Advantage Series analyzer will return to the Temperature Calibrate State. For an unstable condition, conduct one or more of the following steps:
 - a) Wait until the temperature stabilizes,
 - b) Check to see if the TB84PH Advantage Series analyzer has detected a Fault condition by looking for the Fault icon on the LCD. Interrogate the fault by escaping to the Measure Mode through the Exit to MEASURE Key and the FAULT Info Key in that order.
 - c) See Section 14, Troubleshooting.
 - 5) If the reading was stable, enter the temperature as the NEW VAL (i.e., new temperature value) using the ▲ Key to increment the blinking digit and the ► Key to move to the next digit. Press the ENTER Key to enter the new value.
 - 6) Repeat steps 1 through 5 once the sensor has been mounted in its final installed location; however, use the process fluid temperature as the NEW VAL.

Edit Calibrate State

The Edit Calibrate State allows a user to manually adjust the sensor and temperature slope and offset values. Though this function may not be suitable for many applications, this Calibrate State facilitates quick and easy access to these calibration values for troubleshooting purposes.

Conduct an Edit Calibration using the following procedure.

- 1) Select the Edit Calibrate State of Operation using the SELECT Key.
- 2) Edit the sensor PV SLP (i.e., efficiency)

value using the ▲ Key to increment the blinking digit and the ► Key to move to the next digit. Press the ENTER Key to enter the new value or to proceed to the sensor offset value. Press the Exit To MEASURE Key to escape to the Measure Mode. Valid slope values range from 40 to 150%.

- 3) Edit the sensor PV OFF (i.e., offset) value using the ▲ Key to increment the blinking digit and the ► Key to move to the next digit. Press the ENTER Key to enter the new value or to proceed to the temperature slope value. Press the Exit To MEASURE Key to escape to the Measure Mode. Valid offset values range from -1000 to +1000 millivolts.
- 4) Edit the temperature TMP.SLP value using the ▲ Key to increment the blinking digit and the ► Key to move to the next digit. Press the ENTER Key to enter the new value or to proceed to the temperature offset value. Press the Exit To MEASURE Key to escape to the Measure Mode. Valid slope values range from 0.2 to 1.5.
- 5) Edit the temperature TMP.OFF value using the ▲ Key to increment the blinking digit and the ► Key to move to the next digit. Press the ENTER Key to enter the new value or to proceed to the Edit Calibrate State. Press the Exit To MEASURE Key to escape to the Measure Mode. Valid offset values range from -40 to +40°C.

Reset Calibrate State

The Reset Calibrate State sets all calibration data (i.e., sensor and temperature) to factory values. This state purges calibration history and should be initiated before calibrating a new sensor.

When interrogating the calibration values after a reset has been performed, the slope and offset values for both the sensor and temperature will be set to 100%/1.000 and 000 millivolts/000°C, respectively.

Conduct a Reset Calibration using the following procedure.

- 1) Select the Reset Calibrate State of Operation using the SELECT Key.
- 2) Confirm or refuse the RESET? operation using either the YES or NO Key, respectively.

Note: The Reset Calibration State will reset all calibration values; therefore, the process sensor and temperature sensor will require calibration after performing the Reset Calibration procedure.

Analog Output One Calibrate State

The Analog Output One Calibrate State trims the output signal to maintain precise transmission of the process variable to the final monitoring system. Though the TB84PH Advantage Series analyzer output current is factory calibrated, the output can be trimmed to compensate for other Input/Output devices.

Conduct an Output Calibration using the following procedure.

- 1) Select the Output Calibrate State of Operation using the SELECT Key.
- 2) Use the ▲ or ▼ Keys to increase or decrease the 0 or 4 milliampere output signal. Press the ENTER Key to enter the new value or to proceed to the 20 milliampere output level.
- 3) Use the ▲ or ▼ Keys to increase or decrease the 20 milliampere output signal. Press the ENTER Key to enter the new value or to proceed to the Output Calibrate State.

Note: If the output level has been adjusted and the adjusted level has been entered using the Enter Key, this adjusted value will be permanently stored. To rectify a bad calibration, the output calibration procedure must be repeated.

Analog Output Two Calibrate State

The Analog Output Two Calibrate State trims the output signal to maintain precise transmission of the process variable to the final monitoring system. Though the TB84PH Advantage Series analyzer output current is factory calibrated, the output can be trimmed to compensate for other Input/Output devices.

Conduct an Output Calibration using the following procedure.

- 1) Select the Output Calibrate State of Operation using the SELECT Key.
- 2) Use the ▲ or ▼ Keys to increase or decrease the 0 or 4 milliamper output signal. Press the ENTER Key to enter the new value or to proceed to the 20 milliamper output level.
- 3) Use the ▲ or ▼ Keys to increase or decrease the 20 milliamper output signal. Press the ENTER Key to enter the new value or to proceed to the Output Calibrate State.

Note: If the output level has been adjusted and the adjusted level has been entered using the Enter Key, this adjusted value will be permanently stored. To rectify a bad calibration, the output calibration procedure must be repeated.

SECTION 7 - OUTPUT/HOLD MODE

INTRODUCTION

The Output/Hold Mode of Operation provides the ability to set the outputs to fixed levels and/or states, change the output ranges, damp the output signals, or disable the diagnostic spike.

OUTPUT/HOLD STATES OF OPERATION

The Output/Hold Mode consists of six states of operation. Table 7-1 describes the function of each state of operation.

Table 7-1. Output/Hold States

State	Function
HOLD	Used to fix output levels and/or states to values captured when the hold was initiated or to manually entered values, or used to release an existing output HOLD state.
AO1.RNG	Used to change Analog Output One range.
AO2.RNG	Used to change Analog Output Two range.
DAMPNG	Used to reduce fluctuation in the displayed values and/or output signals.
SPIKE	Used to enable or disable the spike output function if configured.

In the Output/Hold Mode, the NEXT Smart Key sequentially moves the user to all other Output/Hold States. The cycle repeats until an Output/Hold State is selected using the SELECT Smart Key or the escape function is chosen using the Exit To MEASURE Smart Key. Use Figure 7-1 to identify Smart Key assignments and the resulting action.

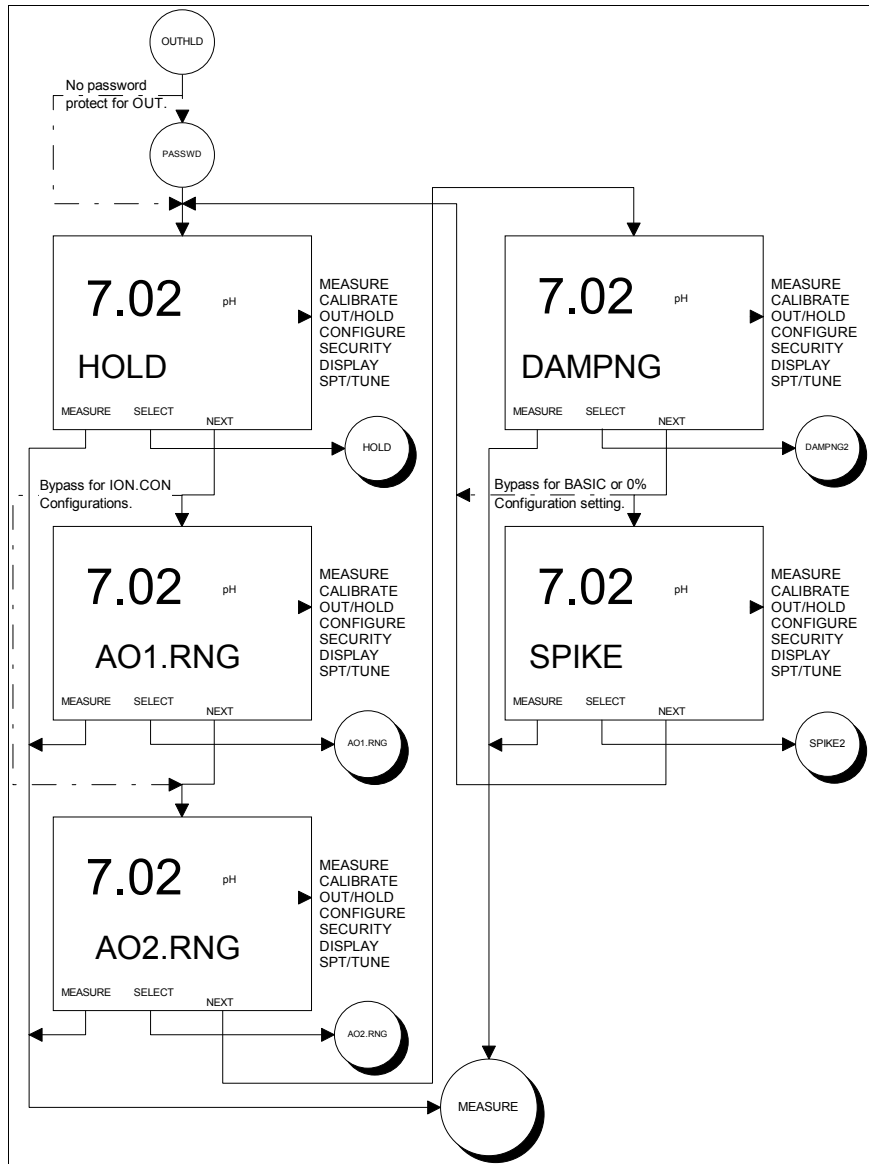

Figure 7-1. Screen Flow Diagrams For Output/Hold States of Operation. The following subsections contain detailed descriptions of each Output/Hold State of Operation.

Hold/Release Hold Output State

The Hold Output State allows a user to fix the analog and relay outputs to captured levels and states or to manually set levels and states, or to release all previously held levels or states.

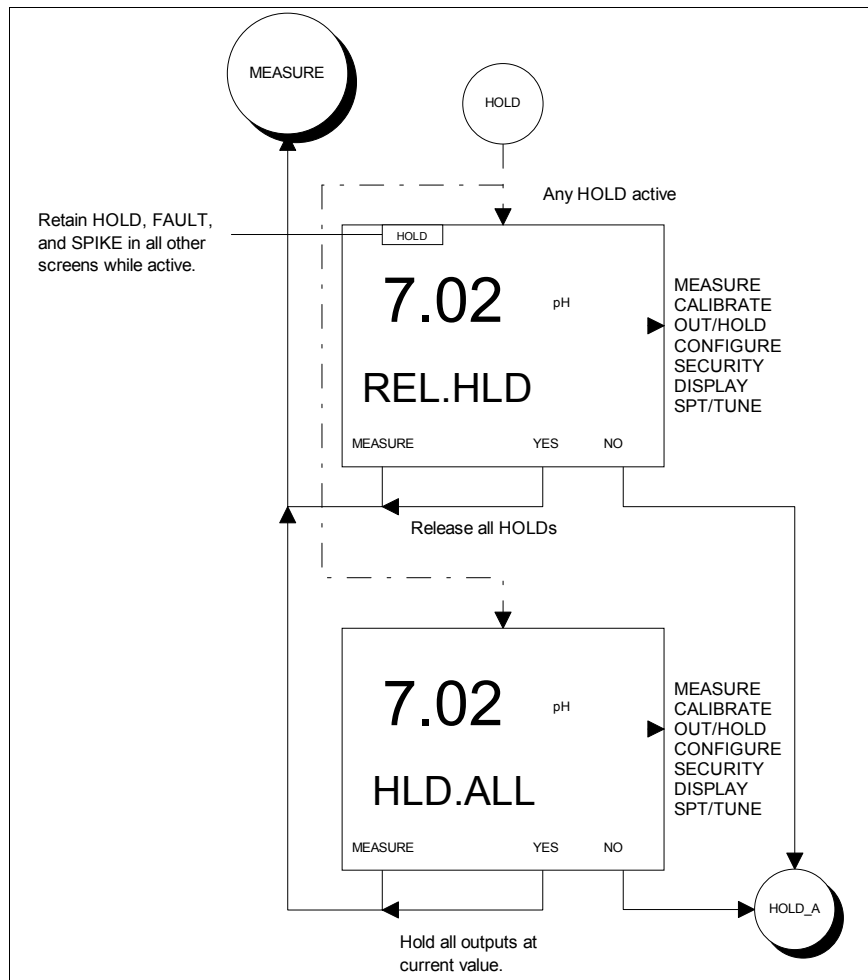

Figure 7-2. Screen Flow Diagrams For Hold State of Operation. As seen by Figure 7-1, an active Hold condition can be completely removed or manually altered. If a Hold condition is not active, the option to Hold All (i.e., HLD.ALL) is given. In the latter case, confirmation of this action using the YES Key causes the TB84PH Advantage Series analyzer to hold all analog and relay outputs at the levels and states captured when confirmation is made.

If a Hold All or Release Hold action is not confirmed by using the NO Key, each output can be independently held to the capture level/state or to a manually set level/state. Figure 7-3 and 7-4 show the programming prompts, smart key assignments, and resulting actions.

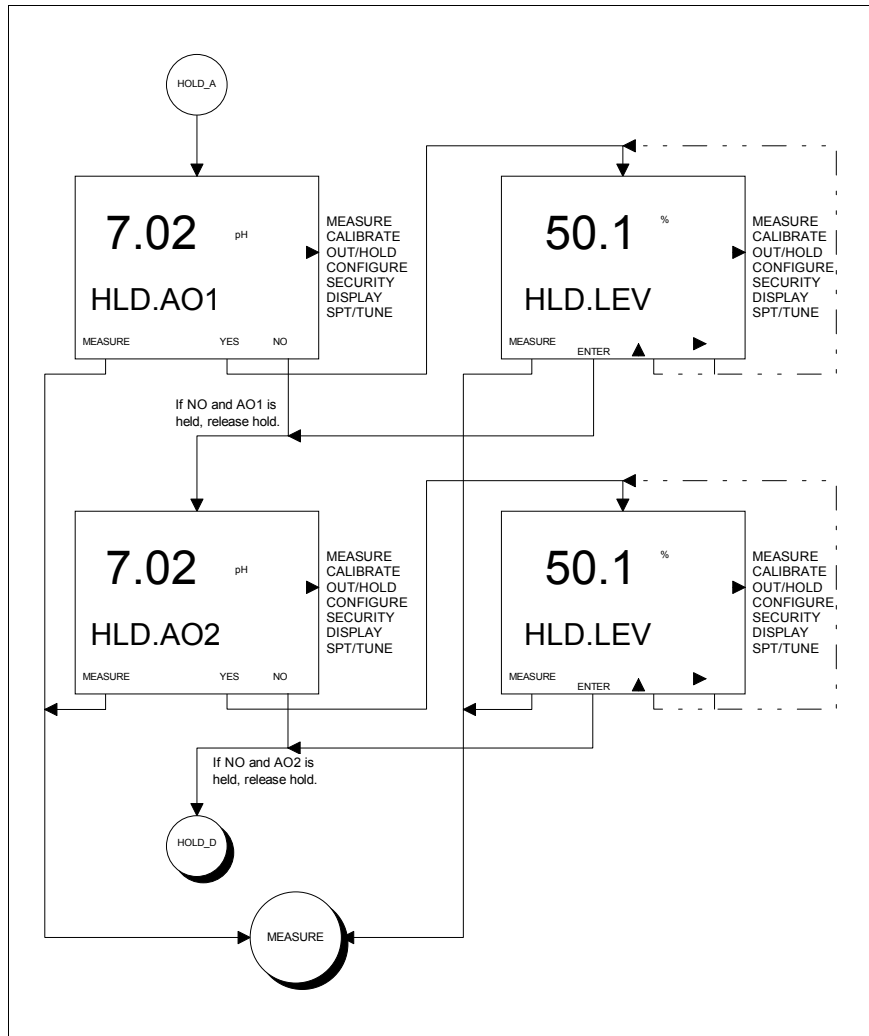

Figure 7-3. Screen Flow Diagram For Setting Specific Analog Output Hold Levels.

As seen by Figures 7-3 and 7-4, any single or combination of analog and relay outputs can be held to any specified level or state, respectively. A Hold condition is commissioned using the YES Key and declined using the NO Key. The hold level and/or state is set using the arrow(s) and Enter Keys.

Initiate a Hold Output condition using Figures 7-2, 7-3, and 7-4 as references and the following procedure:

- 1) Select the Hold State of Operation using the SELECT Key.

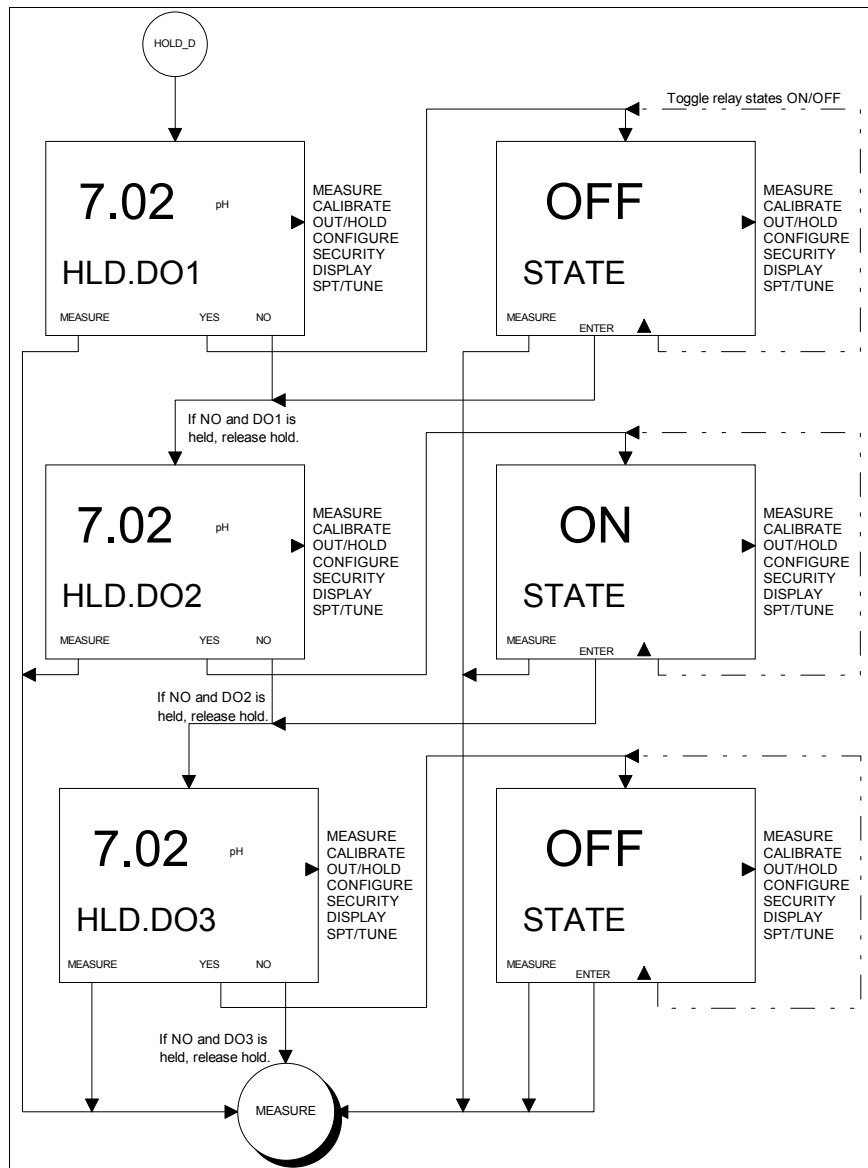

Figure 7-4. Screen Flow Diagram For Setting Specific Hold Relay Output States (HLDs ALL) outputs by pressing the YES Key, or hold specific outputs using the NO Key. Press the Exit To MEASURE Key to escape to the Measure Mode.

- 3) For each output, use the YES Key to hold the indicated output or the NO Key to release the indicated output. Press the Exit To MEASURE Key to escape to the Measure Mode.
- 4) For held analog outputs, set the hold value using the ▲ Key to increment the

blinking digit and the ► Key to move to the next digit, and press the ENTER Key to enter the new value. Press the Exit To MEASURE Key to escape to the Measure Mode.

- 5) For held relay outputs, toggle the relay to the desired state (i.e., OFF or ON) using the ▲ Key, and press the ENTER Key to enter the new value. Press the Exit To MEASURE Key to escape to the Measure Mode.

Note: If the YES key was used to commission a hold condition on any output, initiating the escape function will not affect the commissioned Hold condition. To release this Hold condition, the Hold State must be re-enter and the Hold condition released either by using the YES Key when requested to release all hold conditions (i.e., REL.HLD) or by removing the hold condition using the NO Key when individually setting each output.

If a hold condition(s) already exists and the user selects the Hold State of Operation, the TB84PH Advantage Series analyzer will request whether all hold conditions should be released (i.e., REL.HLD). Press the YES Key if all hold conditions should be released and the NO Key to edit the existing hold conditions.

Analog Output One Rerange State

The Analog Output One Rerange Output/Hold State provides the ability to change the output range of Analog Output One. One or both end point values can be changed to any value or range of values that are within the specifications listed in Table 1-3.

If a non-linear output is configured, reranging the end point values will affect the non-linear relationship. Since the non-linear relationship is set as a percentage input against a percentage output, changing the end point values should accompany a review of the break point relationship. See Section 8, Configure Mode, for information on viewing and modifying the non-linear break points.

Conduct a Rerange of the output values using the following procedure:

- 1) Select the Rerange State of Operation using the SELECT Key.
- 2) Edit the process variable value for the zero or four milliampere point

(determined by the analyzer's configuration) using the ▲ Key to increment the blinking digit and the ► Key to move to the next digit and press the ENTER Key to enter the new value, or press the ENTER Key to continue to the 20 milliampere value. Press the Exit To MEASURE Key to escape to the Measure Mode.

- 3) Press the ENTER or Exit To MEASURE Key to escape to the Measure Mode, or edit the process variable value for the 20 milliampere point using the ▲ Key to increment the blinking digit and the ► Key to move to the next digit and press the ENTER Key to enter the new value.

Note: If 1)the zero or four milliampere value is changed, 2)the new value is valid per the specification in Table 1-3, 3)this change is accepted using the Enter Key, and 4)the user escapes to the Measure Mode using the Exit To Measure Key without adjusting the 20 milliampere value, the output range will now reflect the newly entered zero or four milliampere point.

Analog Output Two Rerange State

The Analog Output Two Rerange Output/Hold State provides the ability to change the output range of Analog Output Two. One or both end point values can be changed to any value or range of values that are within the specifications listed in Table 1-3.

Conduct a Rerange of the output values using the following procedure:

- 1) Select the Rerange State of Operation using the SELECT Key.

-
- 2) Edit the process variable value for the zero or four milliampere point (determined by the analyzer's configuration) using the ▲ Key to increment the blinking digit and the ► Key to move to the next digit and press the ENTER Key to enter the new value, or press the ENTER Key to continue to the 20 milliampere value. Press the Exit To MEASURE Key to escape to the Measure Mode.
 - 3) Press the ENTER or Exit To MEASURE Key to escape to the Measure Mode, or edit the process variable value for the 20 milliampere point using the ▲ Key to increment the blinking digit and the ► Key to move to the next digit and press the ENTER Key to enter the new value.

Note: If 1)the zero or four milliampere value is changed, 2)the new value is valid per the specification in Table 1-3, 3)this change is accepted using the Enter Key, and 4)the user escapes to the Measure Mode using the Exit To Measure Key without adjusting the 20 milliampere value, the output range will now reflect the newly entered zero or four milliampere point.

Damping State

The Damping State applies a lag function on the input signal for Basic configuration or can apply different lag functions to the display process variable, Analog Output One, and Analog Output Two for Advanced configurations. The Damping function reduces the fluctuations caused by erratic process conditions. Damping value can be set from 0.0 to 99.9 seconds and represents the time required to reach 63.2% of a step change.

For Basic configurations, the damping value is applied to the analyzer's input signals. In this case, damping will be applied to the displayed process variables and analog outputs. For Advanced configurations, different damping values can be applied to each output element (i.e., the displayed process variables, Analog Output One, and Analog Output Two.)

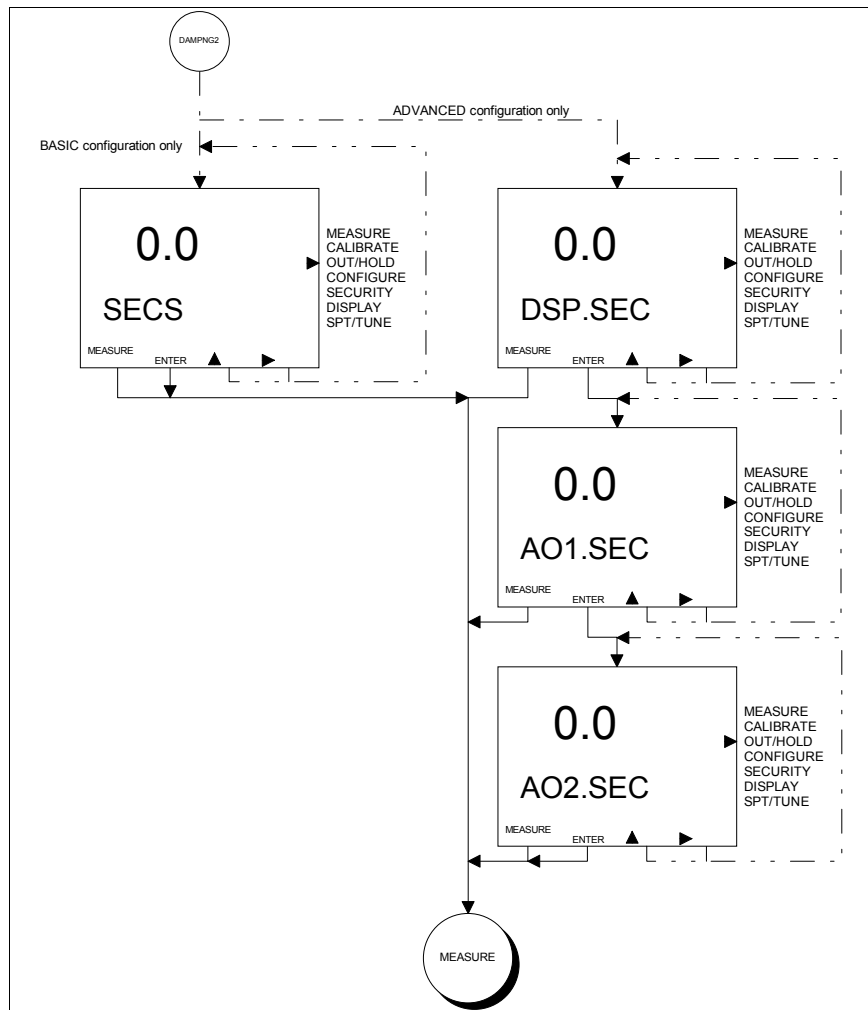

Figure 7-5. Screen Flow Diagram For Output/Hold Damping State

Apply Damping on the outputs using Figure 7-5 as a reference and the following procedure:

- 1) Select the Damping State of Operation using the SELECT Key.
- 2) Edit the new damping value using the ▲ Key to increment the blinking digit and the ► Key to move to the next digit and press the ENTER Key to enter the new value. Press the Exit To MEASURE Key to escape to the Measure Mode.

Spike State

The Spike State toggles the operational state of the spike output function. The spike function modulates the current output on Analog Output One by the amount established in the analyzer configuration. See Section 2, Analyzer Functionality And Operator Interface Controls, and Section 8, Configure Mode, for more information.

Toggle the Spike output using the following procedure:

- 1) Select the Spike State of Operation using the SELECT Key.
- 2) Toggle the spike output function to the desired state (i.e., OFF or ON) using the ▲ Key, and press the ENTER Key to accept. Press the Exit To MEASURE Key to escape to the Measure Mode.

Note: Once the Spike State is OFF, changing the configured spike level in the Configure Mode will not re-enable the Spike State. The Spike State can only be turned ON or OFF in the Output/Hold Mode of Operation.

SECTION 8 - CONFIGURE MODE

INTRODUCTION

The Configure Mode of Operation establishes the operating parameters of the TB84PH Advantage Series analyzer. These parameters include programming type, analyzer type, sensor type, temperature compensation type, analog output ranges, relay output parameters, damping value(s), diagnostic functionality, safe mode levels, and spike magnitude (i.e., level).

A description of each configuration item and related parameters will be included. Review each of the following sections before configuring the TB84PH Advantage Series analyzer.

PRECONFIGURATION DATA REQUIRED

Before attempting to configure the TB84PH Advantage Series analyzer, the following requirements must be defined.

1. Analyzer parameters.
2. Analog Output Range values.
3. Relay Output function and parameters.
4. Security requirements.
5. Sensor Diagnostic functionality.

Use the worksheets found in Appendix C to help establish the proper settings for any given application. Use these sheets during the configuration entry procedure and retain them as a historical record for future reference.

CONFIGURE VIEW/MODIFY STATE

Upon selecting the Configure Mode of Operation, a decision point is reached to Modify or View the configuration of the TB84PH Advantage Series analyzer. The Modify Configure State enables analyzer options to be set and saved into memory. In order to provide the ability to secure the Modify Configure State yet leave the ability to view configuration information, the View Configure State can be entered without using a security code.

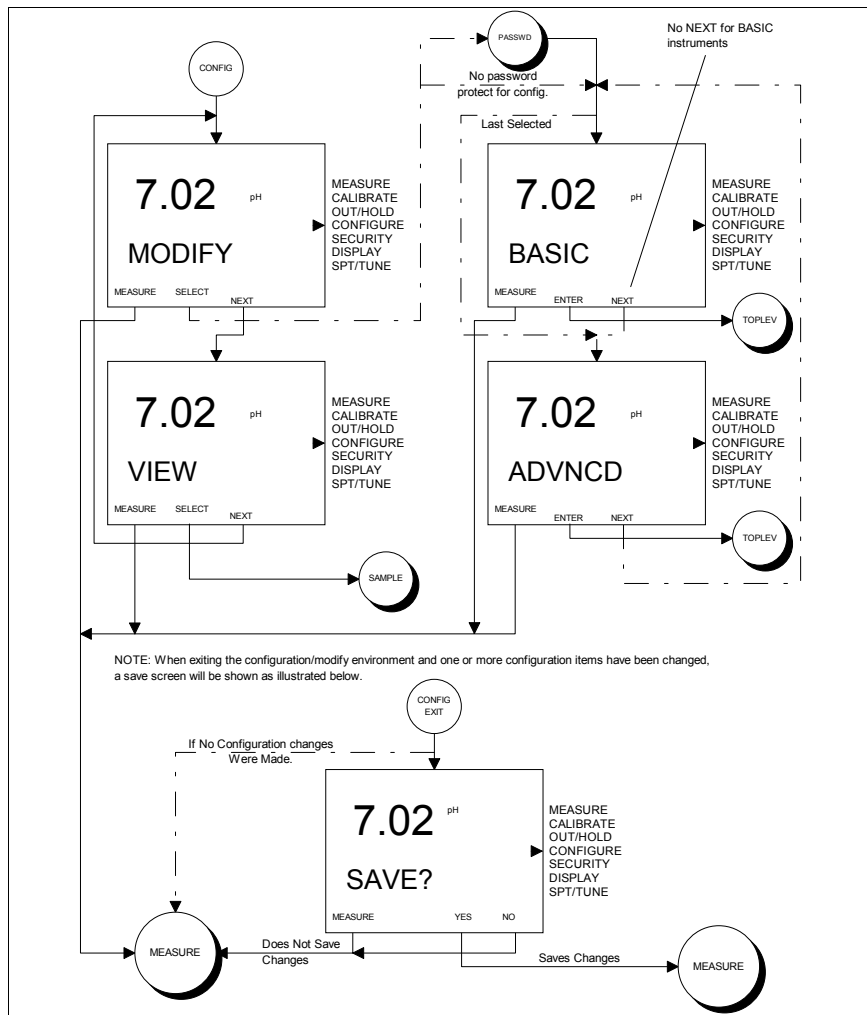

Figure 8-1. Screen Flow Diagram For Modify/View and Basic/Advanced Configure States of Operation 8-1, the TB84PH Advantage Series analyzer queries if the user would like to Modify the configuration. Pressing the YES Smart Key moves the user into the Modify Configure State, pressing the NO Smart Key moves the user to the View configuration query, and pressing the Exit To MEASURE Smart Key escapes to the Measure Mode.

If a configuration requires modification and the user is in the View Configure State, access to the Modify Configure State is provided through a HotKey function. The HotKey links the View Configure State to the Modify Configured State using the ENTER Smart Key. For example, the TMP.SNS (i.e., temperature sensor) in the View Configure State can be modified from PT 100 to None by

pressing the ENTER Smart Key when viewing the PT 100 option. An intermediate confirmation screen will query the user on their desire to modify this option using the YES and NO Smart Keys. If the Modify Configure State has been secured, the security code will be requested. Upon entering the correct code or if the Modify Configure State has not been secured, the TB84PH Advantage Series analyzer will go directly to TMP.SNS Modify Configure State and allow the user to change the temperature sensor type. After completing the change, pressing Exit To MEASURE Smart Key moves the user to the configuration SAVE? State. Pressing the YES Smart Key saves the new temperature sensor option and returns the analyzer to the Measure Mode.

BASIC/ADVANCED PROGRAMMING MODE

The Configure Mode is split into two programming groups: Basic and Advanced. These two options are specified by nomenclature and control the number of configuration options available in the Modify Configure State.

The Basic Programming Mode contains a subset of configuration options found in the Advanced mode. Separation into two programming groups is advantageous when limited functionality is desired. Fewer options reduces confusion and the possibility of configuration errors.

When Advanced programming is ordered, the programming toggle (i.e., Basic/Advanced) must be set in two locations: the User State in the Utility Mode and the Modify Configure State in the Configure Mode. In order to select either the Basic or Advanced Programming Mode in the Modify Configure State, the Programming Mode must be set to Advanced in the User State. See Section 11, Utility Mode, for more information on setting the User State programming mode to Advanced.

When in the Configure Mode and Advanced programming has been set in the User State, the TB84PH Advantage Series analyzer queries if the user would like Basic programming. Pressing the ENTER Smart Key moves the user to the Modify Configure States, pressing the NEXT Smart Key moves the user to the Advanced programming query, and pressing the Exit To MEASURE Smart Key escapes to the Measure Mode. To set the analyzer to Advanced programming, the user presses the ENTER Smart Key when queried to set the programming to Advanced.

See Figure 8-1 for the corresponding screen flows.

MODIFY CONFIGURE STATES OF OPERATION

Since the View Configure State only displays the configured options, the following sections will strictly focus on each Modify Configure State and the available options for these states.

The Modify Configure State contains all the available settings that establishes the functionality of the TB84PH Advantage Series analyzer. Upon receipt of the analyzer, the default configuration (unless otherwise specified by the customer when ordering the TB84PH Advantage Series analyzer) will be used once the analyzer has been powered. See the Preface or Appendix C for the default configuration settings.

Before installing the analyzer, the configuration should be modified to reflect the final installed application. The Modify Configure States define the sensor interface, output parameters, and diagnostic functionality. Table 8-1 describes each of these programming modes and their function.

Table 8-1. Modify Configure States

State	Function	Programming Mode
ANALZER	Used to define the type of analyzer. Choices include pH, ORP, pION, and Ion Concentration (ION.CON).	Basic/Advanced
TMP.SNS	Used to define the type of temperature sensor. Choices include None, Pt100, and 3k Balco.	Basic/Advanced
TC.TYPE	Used to define the type of temperature compensation. Choices include Manual Nernstian, Automatic Nernstian, and Automatic Nernstian with Solution Coefficient.	Basic/Advanced
AO1.OUT	Used to set Analog Output One range.	Basic/Advanced
AO2.OUT	Used to set Analog Output Two range.	Basic/Advanced
RELAY1	Used to set Relay Output One function and parameters. Choices include Setpoint, Cycle Timer, Diagnostics, and Cleaner.	Basic/Advanced
RELAY2	Used to set Relay Output Two function and parameters. Choices include Setpoint, Cycle Timer, Diagnostics, and Cleaner.	Basic/Advanced
RELAY3	Used to set Relay Output Three function and parameters. Choices include Setpoint, Cycle Timer, Diagnostics, and Cleaner.	Basic/Advanced
DAMPNG	Used to reduce fluctuation in the display values and output signals.	Basic/Advanced
DIAGS	Used to set the sensor diagnostics ON or OFF.	Basic/Advanced
SAF.MD.1	Used to define the output signal state for Analog Output One when a detected error results in a condition that renders the analyzer inoperable. Choices include fail Low or fail High.	Basic/Advanced
SAF.MD.2	Used to define the output signal state for Analog Output Two when a detected error results in a condition that renders the analyzer inoperable. Choices include fail Low or fail High.	Basic/Advanced
SPIKE	Used to set the spike magnitude level.	Advanced

As with the other modes and states of operation, the NEXT Smart Key provides access to all Modify Configure States. Pressing the NEXT Smart Key sequentially moves the user through each state. This cycle repeats until a Modify Configure State is selected using the SELECT Smart Key or the escape function is chosen using the Exit To MEASURE Smart Key. Use Figure 8-2 and 8-3 to identify the Smart Key assignments and the resulting action.

When selecting a Modify Configure State, the configured (i.e., active) item within that state will be the first item shown. This item will remain the configured item until a new item is entered and the configuration saved.

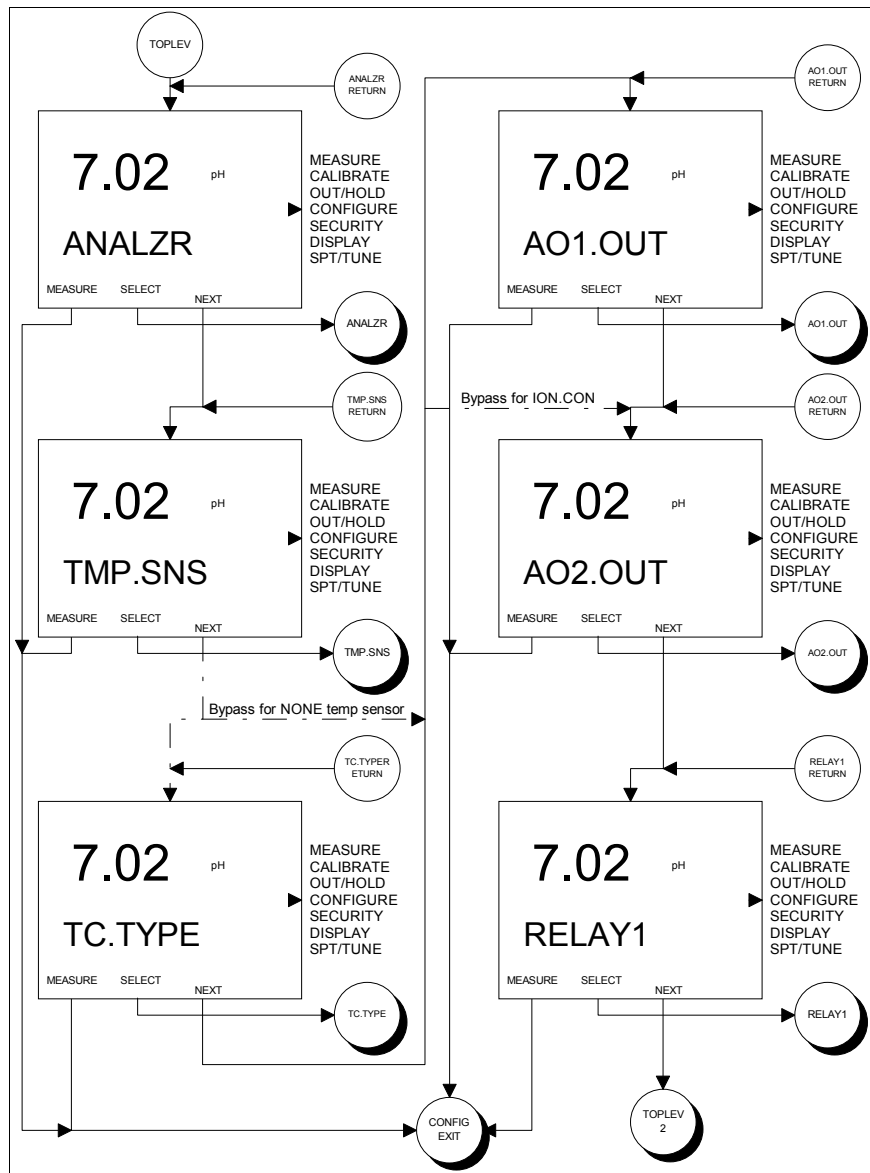

Figure 8-2. Screen Flow Diagram For Modify Configure States of Operation - Part One.

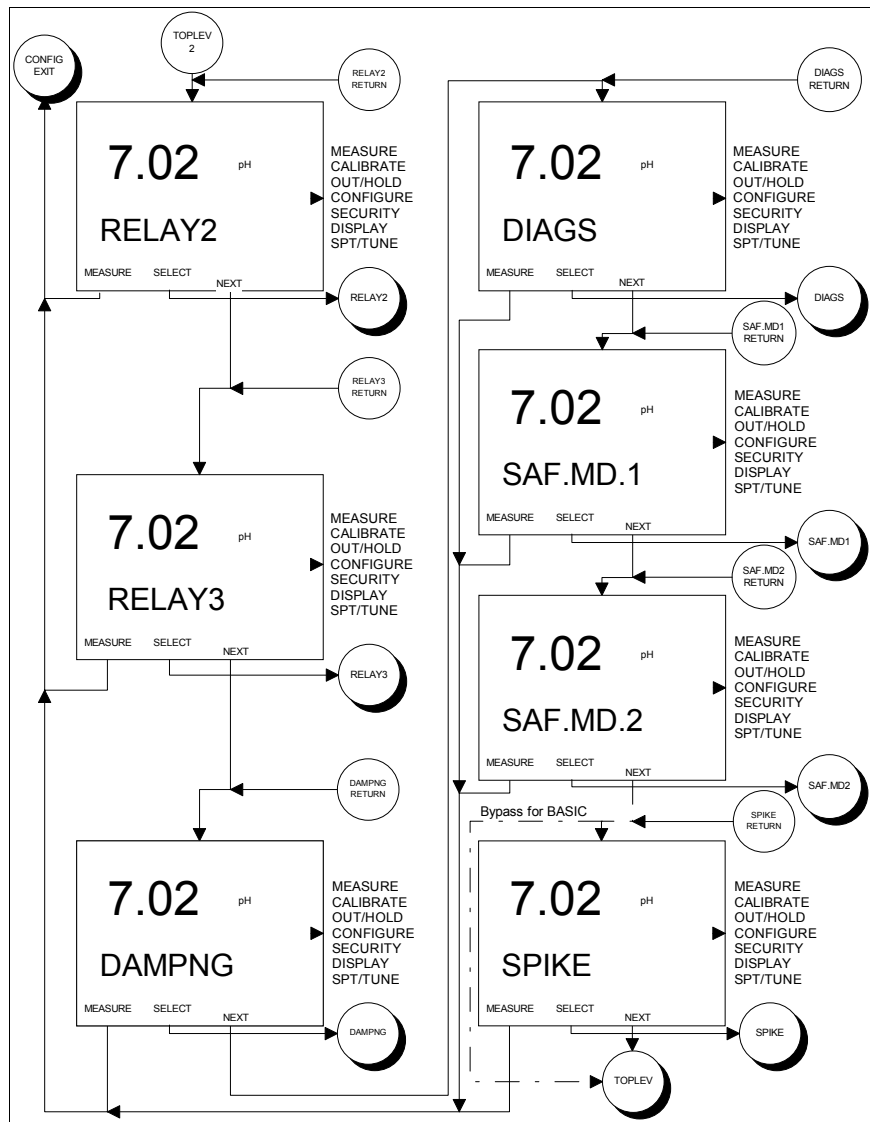

Figure 8-3. Screen Flow Diagram For Modify Configure States of Operation - Part Two. The following subsections contain detailed descriptions of each Modify Configure State of Operation.

Analyzer State (Basic/Advanced)

The Analyzer State sets the type of measurement (i.e., process variable) and must coincide with the type of sensor being used. Table 8-2 describes the function and programming mode of each state.

Table 8-2. Analyzer States

State	Function	Programming Mode
PH	Used to measure the pH of a solution. Process variable engineering units are pH.	Basic/Advanced
ORP	Used to measure the Oxidation Reduction Potential (ORP) of a solution. Process variable engineering units are millivolts (mV).	Basic/Advanced
PION	Used to measure the concentration of a specific ion in a solution. The sensor must use a measurement electrode specific to the ion of interest. Process variable engineering units are millivolts (mV).	Basic/Advanced
ION.CON	Used to measure the concentration of a specific ion in a solution. The sensor must use a measurement electrode specific to the ion of interest. Process variable engineering units are set by the user, and the output is directly proportional to those units and is established by the number of concentration decades.	Advanced

pH Analyzer State (Basic/Advanced)

The pH Analyzer State contains three types of sensors: Glass, Antimony, and Custom. Table 8-3 describes the function and programming mode of each state.

Table 8-3. pH Analyzer States

State	Function	Programming Mode
PH.GLAS	Used when the associated sensor has a standard glass measuring electrode.	Basic/Advanced
ANTMNY	Used when the associated sensor has an antimony measuring electrode.	Basic/Advanced
CUSTOM	Used when the associated sensor has a measuring electrode with a unique isopotential point and asymmetric potential.	Advanced

For Advanced configurations using the PH.GLAS and ANTMNY Analyzer States, the REF Z (i.e., reference impedance) value can be manually set to a new value or left at the default value of 100 kohms. The REF Z is the reference electrode impedance value that will trigger a diagnostic condition. This value is set using

the ▲ Smart Key to increment and the ► Smart Key to move. The ENTER Smart Key accepts the new value. See Section 13, Diagnostics, for more information on diagnostic reporting.

The reference impedance of a new ABB sensor is typically 1 to 2 kohms as measured by the diagnostic circuit of the TB84PH Advantage Series analyzer. Performance of the reference electrode is typically unaffected up to 100 kohms (i.e., the default REF Z value). Adjustment to other resistance values up to 1000 kohms is allowed; however, acceptable performance of the sensor must be determined by the user and the resistance values accordingly adjusted.

For the CUSTOM State, the ISO.PT (i.e., Isopotential pH value) and ASY.POT (i.e., Asymmetric Potential value) must be entered using the ▲ Smart Key to increment the blinking digit, the ► Smart Key to move to the next digit, and the ENTER Smart Key to enter the new value. The REF Z value can also be adjusted and must be set as previously described.

ORP and pION States (Basic/Advanced)

The ORP or pION Analyzer States are set by pressing the ENTER Smart Key on the desired state when displayed using the NEXT Smart Key. For Advanced configurations, the ORP and pION States will require the user to enter the REF Z value. The REF Z (i.e., reference impedance) is the reference electrode impedance value that will trigger a diagnostic condition.

The REF Z value is set using the ▲ Smart Key to increment the blinking digit, the ► Smart Key to move to the next digit, and the ENTER Smart Key to enter the new value. See Section 13, Diagnostics, for more information on diagnostic reporting.

Ion Concentration State (Advanced)

The ION.CON (i.e., Ion Concentration) State allows for pION sensor inputs to be converted to concentration units such as ppb and ppm. This state uses temperature compensated mV values and applies a logarithmic function that has a fixed end point in millivolts, an ion valence ranging from -3 to +3, and an end point magnitude which can be set to 10, 100, or 1000.

The ION.CON State functions by associating an end millivolt value to an end magnitude value. The valence determines the millivolt change per decade of concentration and is defined by the Nernst Equation (i.e., 59.16 mV/decade for a valence equal to 1, 29.58 mV/decade for a valence equal to 2, and 19.72 mV/decade for a valence equal to 3). If the valence is negative the millivolt/concentration relationship will have a negative slope. The number of magnitudes defines the analyzer output. For example, two magnitudes would set the output to 0-10% for the first magnitude and 10-100% for the second magnitude.

Configure an ION.CON Analyzer State using Figure 8-4 as a reference and the following procedure:

- 1) Enter the ION.CON State using the ENTER Key.
- 2) Set the engineering UNIT by toggling to the desired unit using the NEXT Key and entering the unit using the ENTER Key.
- 3) Set the VALENC (i.e., valence) by incrementing or decrementing the displayed value using ▲ and ▼ Keys respectively, and entering the new value using the ENTER Key.

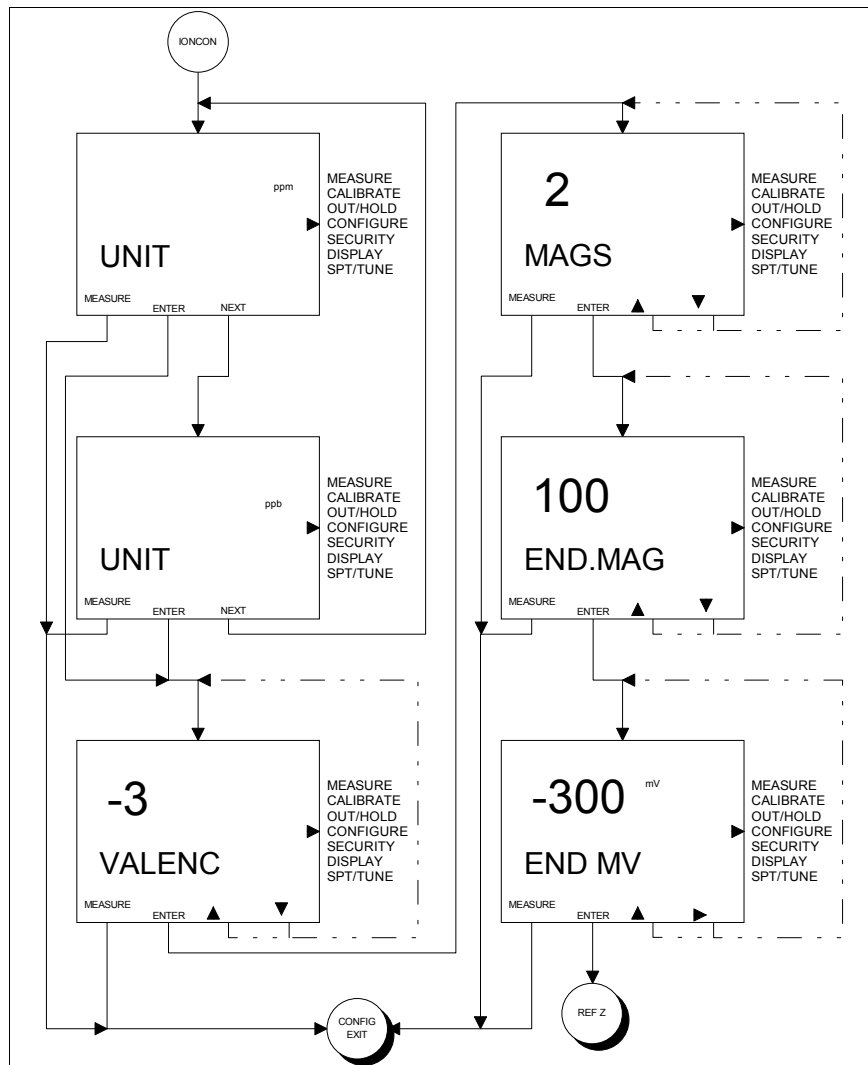

Figure 8-4. Screen Flows For Ion Concentration Configure State of Operation.

- 4) Set the MAGS (i.e., magnitudes) by incrementing or decrementing the displayed value using ▲ and ▼ Keys respectively, and entering the new value using the ENTER Key.
- 5) Set the END.MAG (i.e., ending magnitude) by incrementing or decrementing the displayed value using ▲ and ▼ Keys respectively, and entering the new value using the ENTER Key.
- 6) Set the END MV (i.e., ending millivolt) by using the ▲ Key to increment the blinking digit and the ► Key to move to the next digit and pressing the ENTER Key

to enter the new value.

- 7) Set the REFZ (i.e., reference impedance) by using the ▲ Key to increment the blinking digit and the ► Key to move to the next digit and pressing the ENTER Key to enter the new value.

Temperature Sensor State (Basic/Advanced)

The Temperature Sensor State configures the temperature input for a Pt100, 3 kohm Balco, or no (i.e., NONE) RTD.

Set the Temperature Sensor State using the following procedure.

- 1) Select the TMP.SNS State using the SELECT Key.
- 2) Choose the desired temperature sensor by using the NEXT Key to toggle between NONE, 3K.BLCO (i.e., 3 kohm Balco), and PT100, and enter the temperature sensor by using the ENTER Key when the correct sensor is displayed in the secondary display.

Temperature Compensation State (Basic/Advanced)

Temperature affects the process variable in two ways. The first effect (i.e., Nernstian Effect) causes the sensor output to increase with increasing temperature. In the case of a pH sensor, the increase is roughly 0.03 pH/pH Unit From 7pH/10°C. Since ABB pH sensors use Silver/Silver Chloride Measurement and Reference Half Cells, the isopotential point (i.e., the pH value that is unaffected by temperature) of these sensors is 7 pH.

The second temperature effect is on the actual chemistry of the solution. Since ion disassociation can be a function of temperature, ion properties such as pH, ORP, and pION are affected by changes in process temperature. These effects can be empirically determined and included in the temperature compensation process using the Automatic Nernstian with Solution Coefficient Temperature Compensation option.

The Temperature Compensation State sets the desired compensating method. The three states of temperature compensation include Manual Nernstian, Automatic Nernstian, and Automatic Nernstian with Solution Coefficient. Table 8-

4 describes the function and programming mode of each state.

Table 8-4. Temperature Compensation States

State	Function	Programming Mode
MANUAL	Used when a fixed temperature value can be applied instead of a measured value. The initial value is set at 25°C. Use the Temperature Calibrate State to change the fixed temperature value. Nernstian compensation is applied using the fixed temperature value.	Basic/Advanced
AUTO	Used when a measured temperature value is being provided by a temperature sensor. Nernstian compensation is applied using the measured value.	Basic/Advanced
AUT.SOL	Used when a measured temperature value is being provided by a temperature sensor. Nernstian compensation and a solution coefficient is applied using the measured value.	Advanced

Manual Nernstian State (Basic/Advanced)

Manual temperature compensation adjusts for temperature effects of the sensor at a specific temperature. A temperature sensor is not required (i.e., NONE for TMP.SNS). The Manual Nernstian State is only applicable for pH Analyzer States. The displayed process variable (i.e., pH) is standardized to 25°C.

When using the Manual Nernstian State, the process temperature will be automatically set to 25°C. To adjust the temperature to other values, use the Temperature Calibrate State and set the temperature to the new value as specified in Section 6, Calibrate Mode. The allowable solution temperature range is 0 to 140°C.

Set the Temperature Compensation State to Manual Nernstian State using the following procedure:

- 1) Select the TC.TYPE State using the Select Key.
- 2) Move to the MANUAL Nernstian State using the Next Key.
- 3) Set the TC.TYPE to MANUAL using the Enter Key.

Automatic Nernstian State (Basic/Advanced)

Automatic Nernstian temperature compensation requires an input from a temperature sensing device. The input can be either from a Pt100 or 3 kohm Balco RTD.

Automatic Nernstian temperature compensation corrects for temperature effects caused by sensor and is only applicable for the pH Analyzer State. The displayed process variable (i.e., pH) is standardized to 25°C, and the allowable solution temperature range is 0 to 140°C.

Set the Temperature Compensation State to Automatic Nernstian State using the following procedure:

- 1) Select the TC.TYPE State using the Select Key.
- 2) Move to the AUTO Nernstian State using the Next Key.
- 3) Set the TC.TYPE to AUTO using the Enter Key.

Automatic Nernstian With Solution Coefficient State (Advanced)

The Automatic Nernstian With Solution Coefficient State compensates the sensor output to a reference temperature of 25°C using the Nernst Equation and a solution

coefficient. The solution coefficient is entered as the change in pH Units/10°C for the pH Analyzer State and has the range of +/- 1.999 pH units/10°C, or the change in mV/10°C for ORP, pION, and ION.CON Analyzer States and has the range of +/- 19.99 mV/10°C.

This compensation method requires an input from a temperature sensing device. The input can be either from a Pt100 or 3 kohm Balco RTD, and the allowable solution temperature range is 0 to 140°C.

The standardized, displayed process variable complies with the following formula:

$$\text{StandardAutopH}\pm\text{Sol.Coef.} \times \frac{\text{Temp.EC}\&25\text{EC}}{10\text{EC}}$$

CAUTION	Automatic Nernstian With Solution Coefficient compensation can only be used for processes that are extremely repeatable.
----------------	---

To use this type of compensation, a representative sample of the process must be taken, and the measured parameter (i.e., pH, ORP, or pION) must be determined using the TB84PH Advantage Series analyzer set to Automatic Nernstian compensation and a sensor with a temperature sensing device. A representative process sample must be measured at two different temperatures indicative of the range of process solution temperatures expected in the final installed location. The change in the process variable between the two temperatures must be divided by the temperature difference, and this quantity multiplied by 10. If the process variable decreased as temperature increased, the coefficient must be positive (+). Conversely, if the process variable increased as temperature increased, the coefficient must be negative (-).

Set the Temperature Compensation State to Automatic Nernstian With Solution Coefficient State using the following procedure:

- 1) Select the TC.TYPE State using the SELECT Key.
- 2) Move to the AUT.SOL (i.e., Automatic Nernstian With Solution Coefficient)

State using the NEXT Key.

- 3) Set the TC.TYPE to AUT.SOL using the ENTER Key.
- 4) Set the PH/10C or MV/10C value (as the case may be) using the ▲ Key to increment the blinking digit and the ► Key to move to the next digit and pressing the ENTER Key to enter the new value.

Analog Output One State (Basic/Advanced)

The Analog Output One State sets the output span, range, and function. The output span is software selectable for either zero to 20 milliamperes or four to 20 milliamperes and is source to the Primary Process Variable. For Basic configurations, the output function can only be linear. Lower and upper range values must be entered and are defaulted to the full scale process variable range (e.g., 0-14 pH for pH Analyzer States). For Advanced configurations, the output function can be linear or non-linear. For a non-linear output, lower and upper range values must also be entered as well as five break points.

Linear Output State (Basic/Advanced)

The Linear Output State establishes the lower and upper range values. The default values for the output represent the full scale process variable range (e.g., 0-14 pH).

For a reverse acting output, reverse the zero or four and 20 milliampere values (e.g., 14 pH for the zero or four milliampere value and 0 pH for the 20 milliampere value).

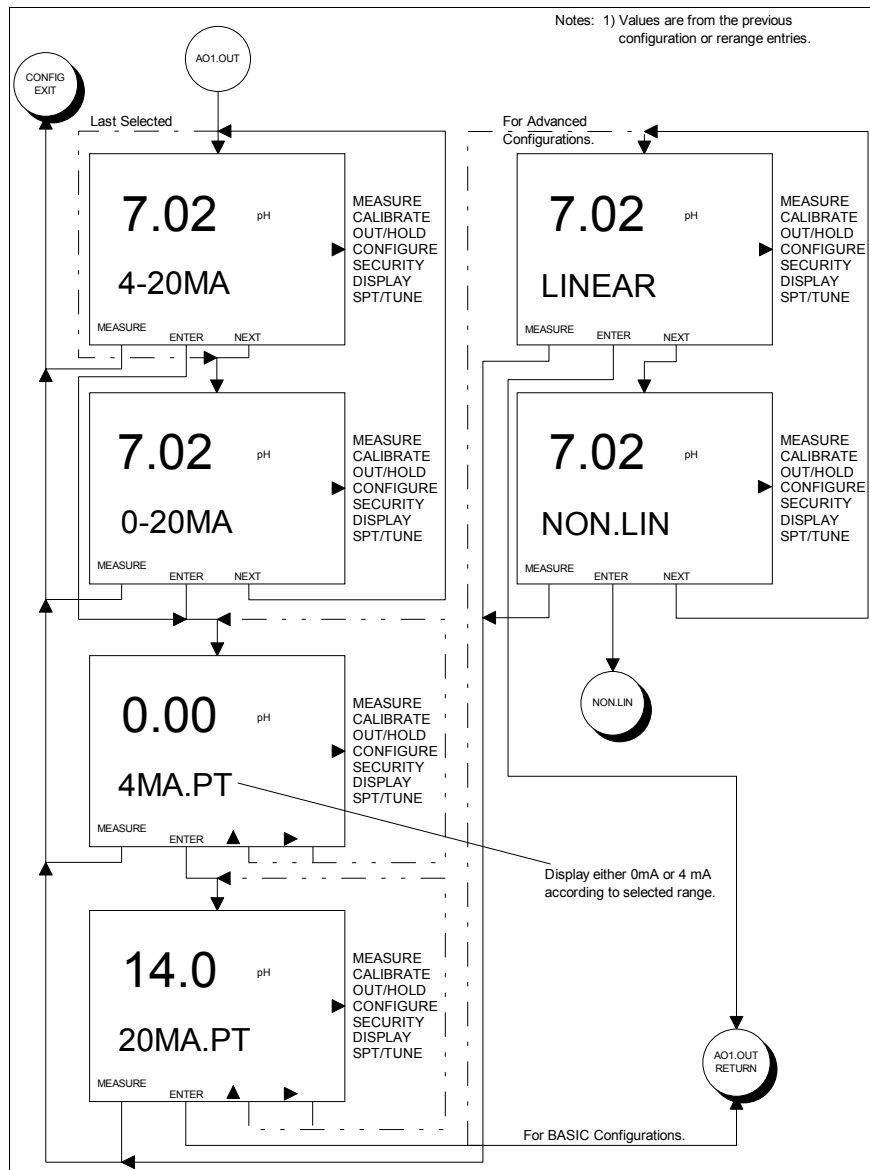

Figure 8-5. Screen Flow Diagram For Analog Output One Configure State of Operation. Set the Linear Output State using Figure 8-5 as reference and the following procedure:

- 1) Select the AO1.OUTPUT State using the SELECT Key.
- 2) Set the output span using the NEXT Key to toggle between 4-20MA and 0-20MA, and press the ENTER Key to enter the new span.
- 3) Set the process variable value for the 0 or 4 milliamper point using the ▲ Key

to increment the blinking digit and the ► Key to move to the next digit, and press the ENTER Key to enter the new value.

- 4) Set the process variable value for the 20 milliampere point using the ▲ Key to increment the blinking digit and the ► Key to move to the next digit, and press the ENTER Key to enter the new value.
- 5) Select the LINEAR Output State using the SELECT Key for Advanced configurations. For Basic configurations, this step will not be accessible.

Non-Linear Output State (Advanced)

The Non-Linear Output State sets the end point and break point values for a non-linear output function. The default values for the output represent the full scale process variable range (e.g., 0 to 14 or -1999 to +1999 mV) and the break points are set for a linear output (e.g., 20% input equals 20% output).

To define the break point values, a plot of the process variable against the desired output (or variable that represents the output value) must be segmented into six linear regions that best fit the non-linear relationship. The points where the linear regions intersect should fall on the non-linear function and represent the break points that are entered into Non-Linear Output State.

As with the Linear Output State, the output range must be defined and will represent the 0% input/0% output and 100% input/100% output points. Since the 0% and 100% points are defined by the output range, the break point information (e.g., X-1/Y-1, X-2/Y-2, etc. values) should not include the 0% input/0% output and 100% input/100% output values and must be entered as percentage of input range and output span. Also as with a linear output, a reverse acting non-linear output can be implemented by reversing the zero or four and 20 milliampere process variable and break point values (e.g., 1999 mV for the 4 milliampere value and -1999 mV for the 20 milliampere value).

Set the Analog Output One Non-Linear State using Figure 8-5 as a reference and the following procedure:

-
- 1) Select the A02.OUT State using the SELECT Key.
 - 2) Set the output span using the NEXT Key to toggle between 4-20MA and 0-20MA, and press the ENTER Key to enter the new span.
 - 3) Set the process variable value for the zero or four milliampere point using the ▲ Key to increment the blinking digit and the ► Key to move to the next digit, and press the ENTER Key to enter the new value.
 - 4) Set the process variable value for the 20 milliampere point using the ▲ Key to increment the blinking digit and the ► Key to move to the next digit, and press the ENTER Key to enter the new value.
 - 4) Select the NON.LIN Output State by using the NEXT Key to change the programming state from LINEAR to NON.LIN and using the SELECT Key to accept the NON.LIN Output State.
 - 5) Set the input percentage for the first break point (X-1) using the ▲ Key to increment the blinking digit and the ► Key to move to the next digit, and press the ENTER Key to enter the new value.

- 6) Set the output percentage for the first break point (Y-1) using the ▲ Key to increment the blinking digit and the ► Key to move to the next digit, and press the ENTER Key to enter the new value.
- 7) Repeat steps 5 and 6 for the remaining four break points.

Table 8-5. Non-linear Output Example Values

Break Point	ORP Signal (mV)	Output Range (mA)	Percent Input (%)	Percent Output (%)
	0	4.0	0	0
1	120	5.6	20	10
2	270	8.8	45	30
3	360	12.0	60	50
4	420	15.2	70	70
5	540	19.2	90	95
	600	20.0	100	100

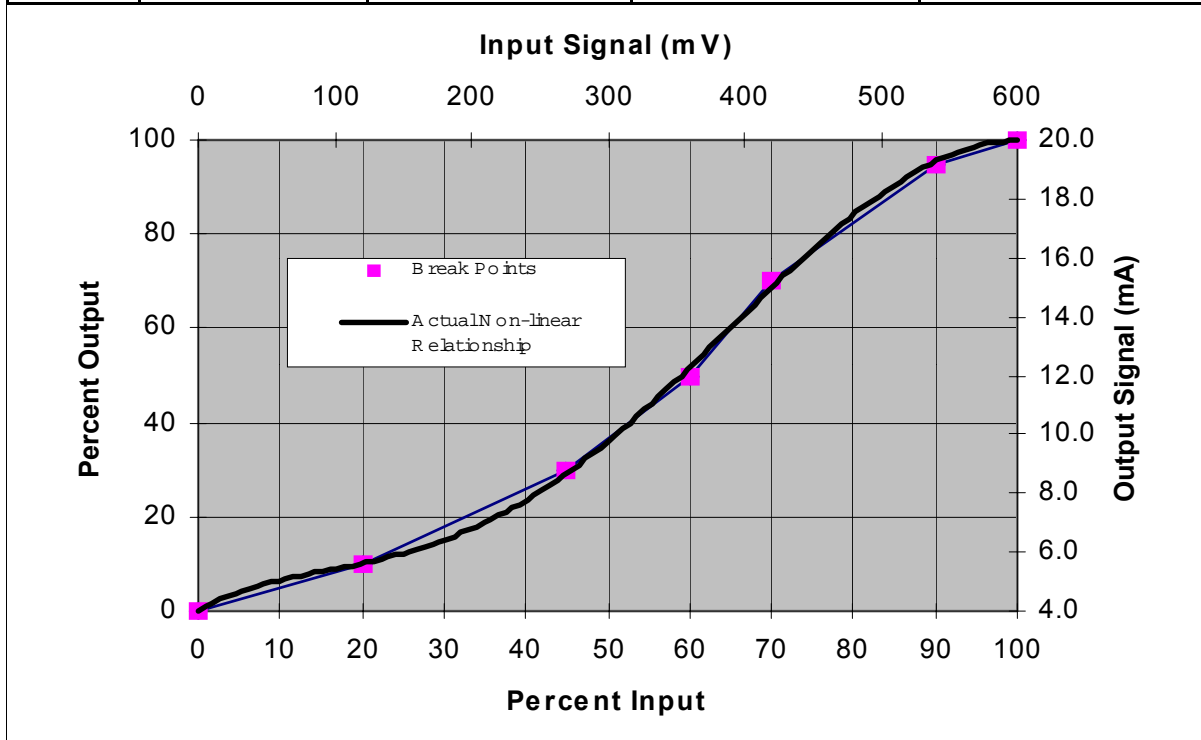

Figure 8-6. Non-linear Output Break Point Determination.

Table 8-5 and Figure 8-6 illustrate the use of the Non-linear Output function. This information is only for illustration purposes

and does not characterize any specific application.

Analog Output Two State (Basic/Advanced)

The Analog Output Two State sets the output source, span, and range. The output can be sourced to the Primary Process Variable or Temperature. As with Analog Output One, the output span is software selectable for either zero to 20 milliamperes or four to 20 milliamperes. The output function is always linear. Lower and upper range values must be entered and are defaulted to the full scale process variable range (e.g., 0-14 pH for pH Analyzer States).

Set the Analog Output Two State using Figure 8-7 as reference and the following procedure:

- 1) Select the AO2.OUT State using the SELECT Key.
- 2) Set the output source using the NEXT Key to toggle between PV and TEMP, and press the ENTER Key to enter the new source.
- 3) Set the output span using the NEXT Key to toggle between 4-20MA and 0-20MA, and press the ENTER Key to enter the new span.
- 4) Set the process variable value for the 0 or 4 milliampere point using the ▲ Key to increment the blinking digit and the ► Key to move to the next digit, and press the ENTER Key to enter the new value.
- 5) Set the process variable value for the 20 milliampere point using the ▲ Key to increment the blinking digit and the ► Key to move to the next digit, and press the ENTER Key to enter the new value.

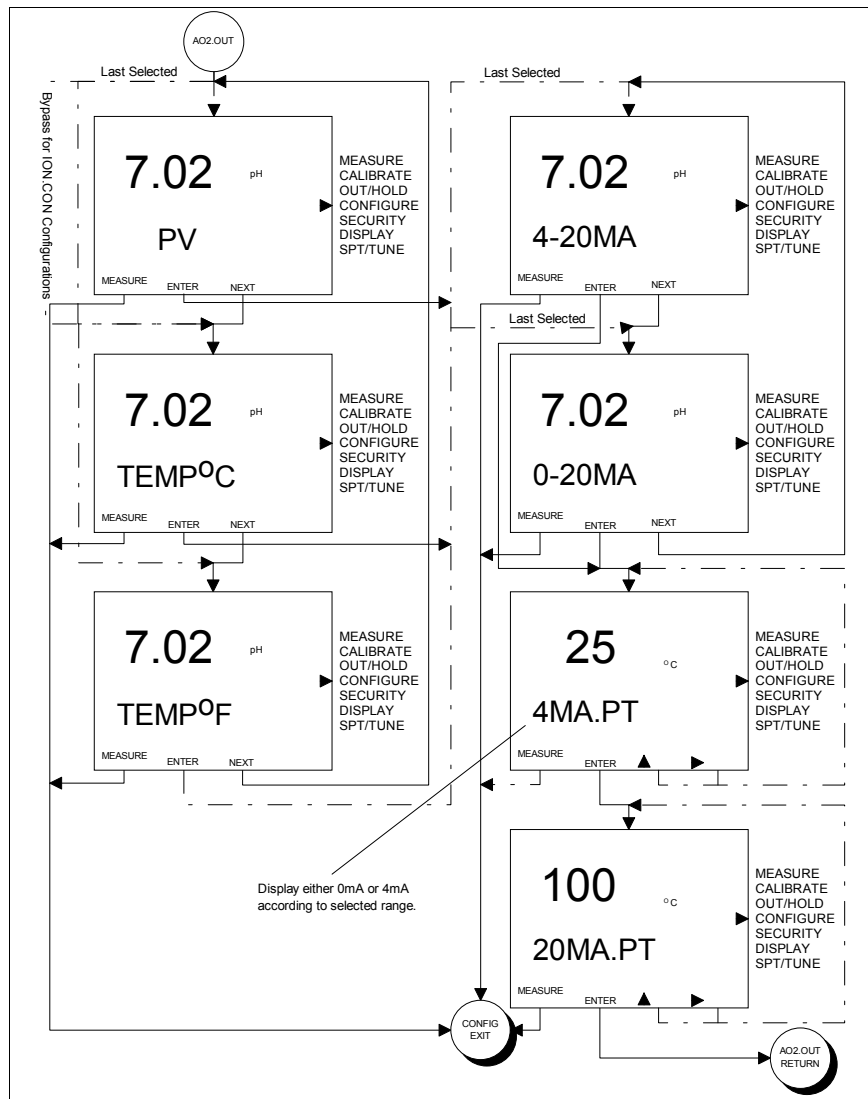

Figure 8-7. Screen Flow Diagram For Analog Output Two Configure State of Operation.

Relay Output One (Basic/Advanced)

The Relay Output One State sets the output function and related parameters for Relay Output One. The output function is dependent on the programming mode. For Basic configurations, Relay One output functions are limited to Setpoint control of the Process Variable. For Advanced configurations, the output functions are not limited and can be configured as a Setpoint sourced to the Process Variable or Temperature, Cycle Timer, Diagnostic, or Cleaner.

Set the output function of Relay Output One State using Figure 8-8 as reference and the

following procedure:

- 1) Select the RELAY1 State using the SELECT Key.
- 2) Set the output function using the NEXT Key to toggle between HI.PV and LO.PV for Basic Configurations or HI.PV, LO.PV, HI.TMP.C (i.e., High Temperature in Celsius), LO.TMP.C, HI.TMP.F (i.e., High Temperature in Fahrenheit), LO.TMP.F, DIAGS (i.e, Diagnostics), HI.PV.CT (i.e., High Process Variable Cycle Timer), LO.PV.CT, or CLNR (i.e., Cleaner), and press the ENTER Key to enter the new output function.

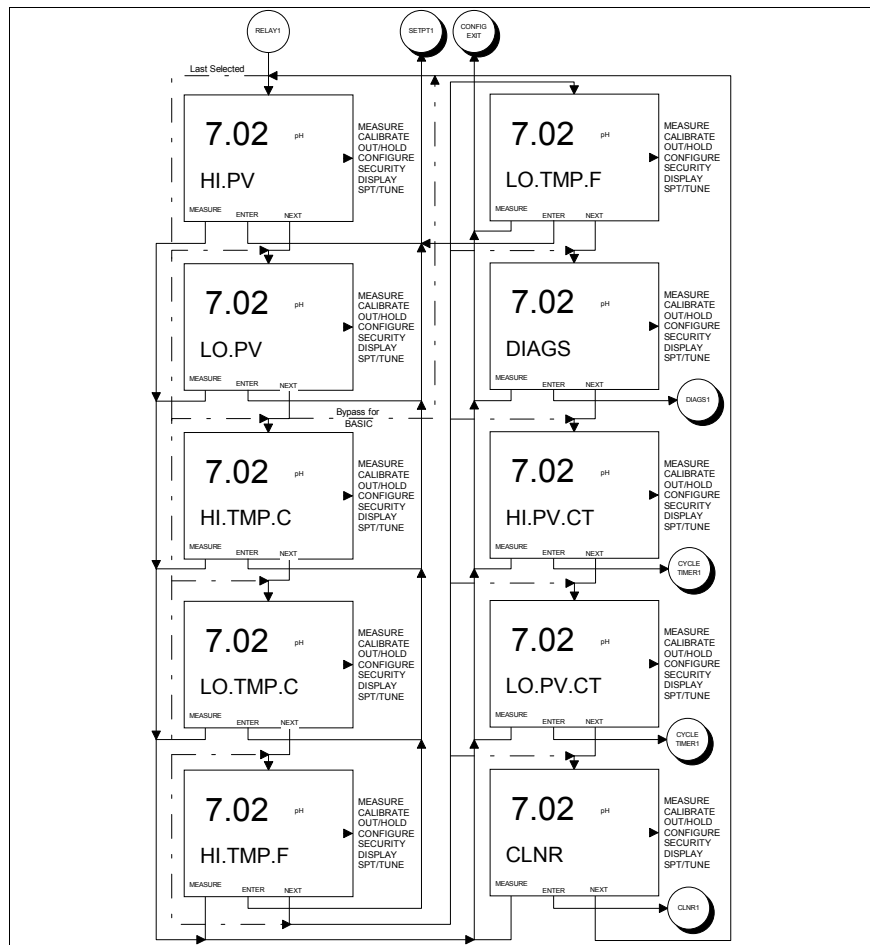

Figure 8-8. Screen Flow Diagram For Relay Output One Configure State of Operation.

Since the parameters for each type of relay function are the same, this information will be given after reviewing the applicable functions for each relay output.

Relay Output Two (Basic/Advanced)

The Relay Output Two State sets the output function and related parameters for Relay Output Two. The output function is dependent on the programming mode. For Basic configurations, Relay Two output functions are limited to Setpoint control of the Process Variable and Temperature. For Advanced configurations, the output functions are not limited and can be configured as a Setpoint sourced to the Process Variable or Temperature, Cycle Timer, Diagnostic, or Cleaner.

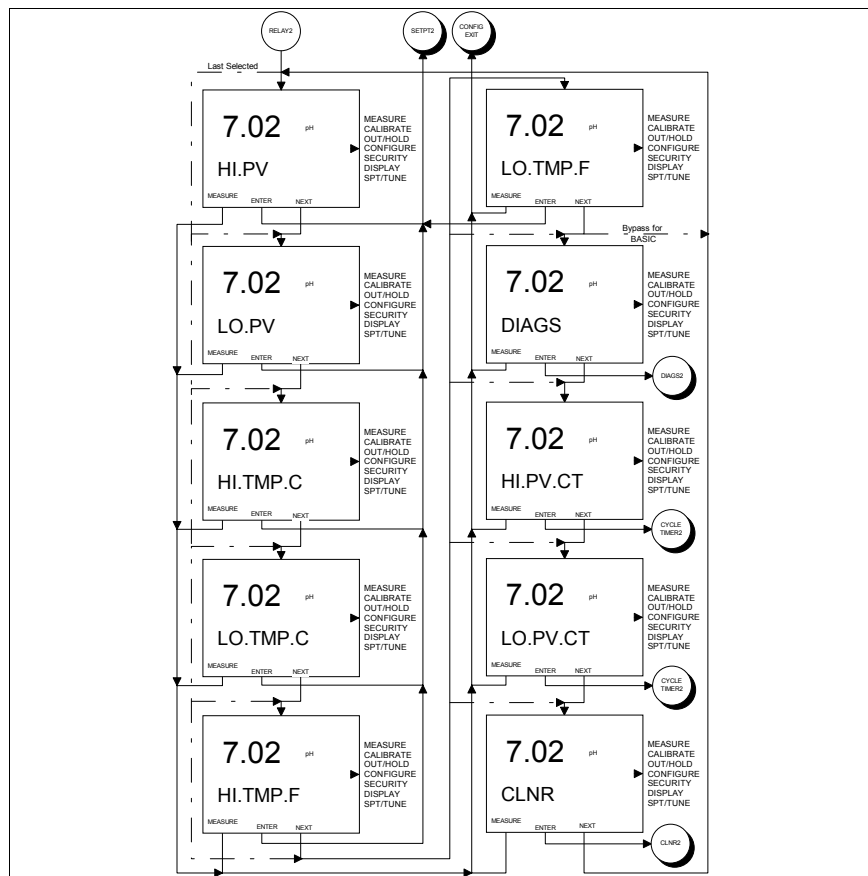

Figure 8-9. Screen Flow Diagram For Relay Output Two Configure State of Operation. Set the output function of Relay Output Two State using Figure 8-9 as reference and the following procedure:

- 1) Select the RELAY2 State using the SELECT Key.
- 2) Set the output function using the NEXT Key to toggle between HI.PV, LO.PV,

HI.TMP.C, LO.TMP.C, HI.TMP.F, and
LO.TMP.F for Basic Configurations or
HI.PV, LO.PV, HI.TMP.C, LO.TMP.C,
HI.TMP.F, LO.TMP.F, DIAGS, HI.PV.CT,
LO.PV.CT, or CLNR, and press the ENTER
Key to enter the new function.

Since the parameters for each type of relay function are the same, this information will be given after reviewing the applicable functions for each relay output.

Relay Output Three (Basic/Advanced)

The Relay Output Three State sets the output function and parameters for Relay Output Three. The output function is dependent on the programming mode. For Basic configurations, Relay Three output functions are limited to Setpoint control of the Process Variable and Temperature and Diagnostic notification. For Advanced configurations, the output functions are not limited and can be configured as a Setpoint sourced to the Process Variable or Temperature, Cycle Timer, Diagnostic, or Cleaner.

Set the output function of Relay Output Three State using Figure 8-10 as reference and the following procedure:

- 1) Select the RELAY3 State using the SELECT Key.

- 2) Set the output function using the NEXT Key to toggle between HI.PV, LO.PV, HI.TMP.C, LO.TMP.C, HI.TMP.F, LO.TMP.F, and DIAGS for Basic Configurations or HI.PV, LO.PV, HI.TMP.C, LO.TMP.C, HI.TMP.F, LO.TMP.F, DIAGS, HI.PV.CT, LO.PV.CT, or CLNR, and press the ENTER Key to enter the new function.

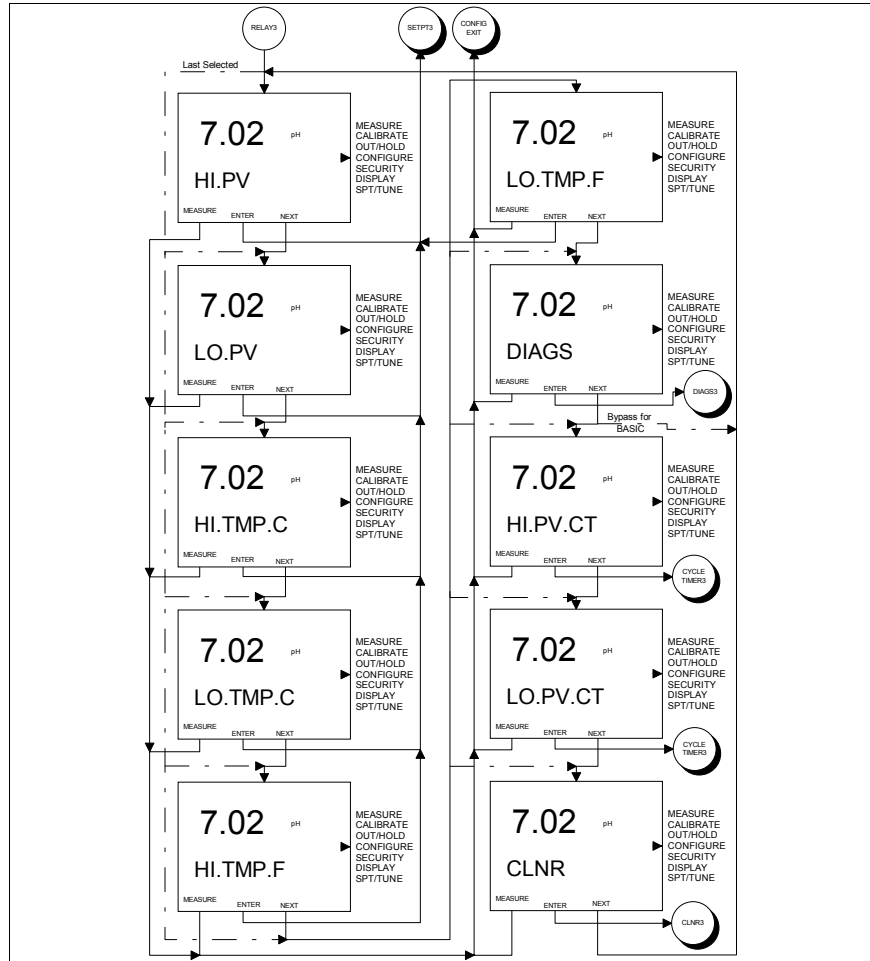

Figure 8-10. Screen Flow Diagram For Relay Output Three Configure State of Operation.

Since the parameters for each type of relay function are the same, this information will be given after reviewing the applicable functions for each relay output.

Setpoint Relay Output (Basic/Advanced)

A Setpoint Relay Output can be configured to energize when the Process Variable or Temperature exceeds (i.e., a High Setpoint) or falls below (i.e., a Low Setpoint) a defined level. Valid Setpoint values are limited to the Process Variable and/or Temperature range of the TB84PH Advantage Series analyzer. See Table 1-3, Specifications, for analyzer range values.

To prevent relay chatter, a Setpoint Relay Output has an configurable Deadband. The Deadband control keeps the relay energized until the Process Variable or Temperature has decreased below a High Setpoint value or above a Low Setpoint value by the Deadband value. Valid Deadband values are 0.00 to 10.00 pH for pH, 0 to 200 mV for ORP and pION, 0 to 10% of the END.MAG (i.e., End Magnitude) for Ion Concentration Process Variable sources and 0 to 10°C (18°F) for Temperature sources.

A Time Delay control also refines the function of a Setpoint Relay. Entering a Time Delay value greater than 0.0 minutes enables a waiting period before energizing the relay once the setpoint condition has been met. Valid Time Delay values are 0.0 to 99.9 minutes.

Set the Setpoint parameters of a Relay Output using Figure 8-11 as reference and the following procedure:

- 1) Set the Setpoint (i.e., LO SPT or HI SPT) using the ▲ Key to increment the blinking digit and the ► Key to move to the next digit, and press the ENTER Key to enter the new value.
- 2) Set the Deadband (i.e., DBAND) using the ▲ Key to increment the blinking digit and the ► Key to move to the next digit and, press the ENTER Key to enter the new value.

- 3) Set the Time Delay in minutes (i.e., DLY.MIN) using the ▲ Key to increment the blinking digit and the ► Key to move to the next digit, and press the ENTER Key to enter the new value.

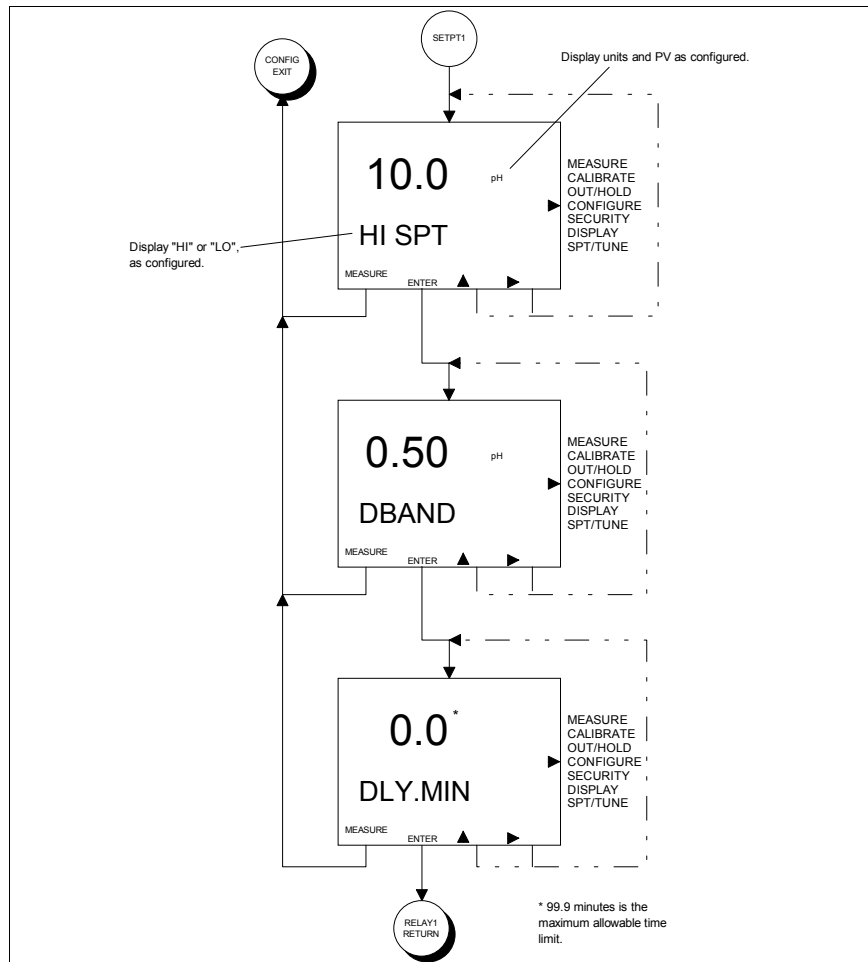

Figure 8-11. Screen Flow Diagram For Setting the Setpoint Relay Output Configure State of Operation.

Diagnostic Relay Output (Basic/Advanced)

A Diagnostic Relay Output simply energizes when a diagnostic condition has been detected. The relay can be configured to trigger on a sensor, instrument, or all diagnostic conditions.

Set the trigger for the Diagnostic Relay Output using Figure 8-12 as reference and the following procedure:

- 1) Set the Diagnostic trigger using the NEXT Key to toggle between ALL, SENSOR, and INSTR. (i.e., Instrument), and press the ENTER Key to enter the new trigger.

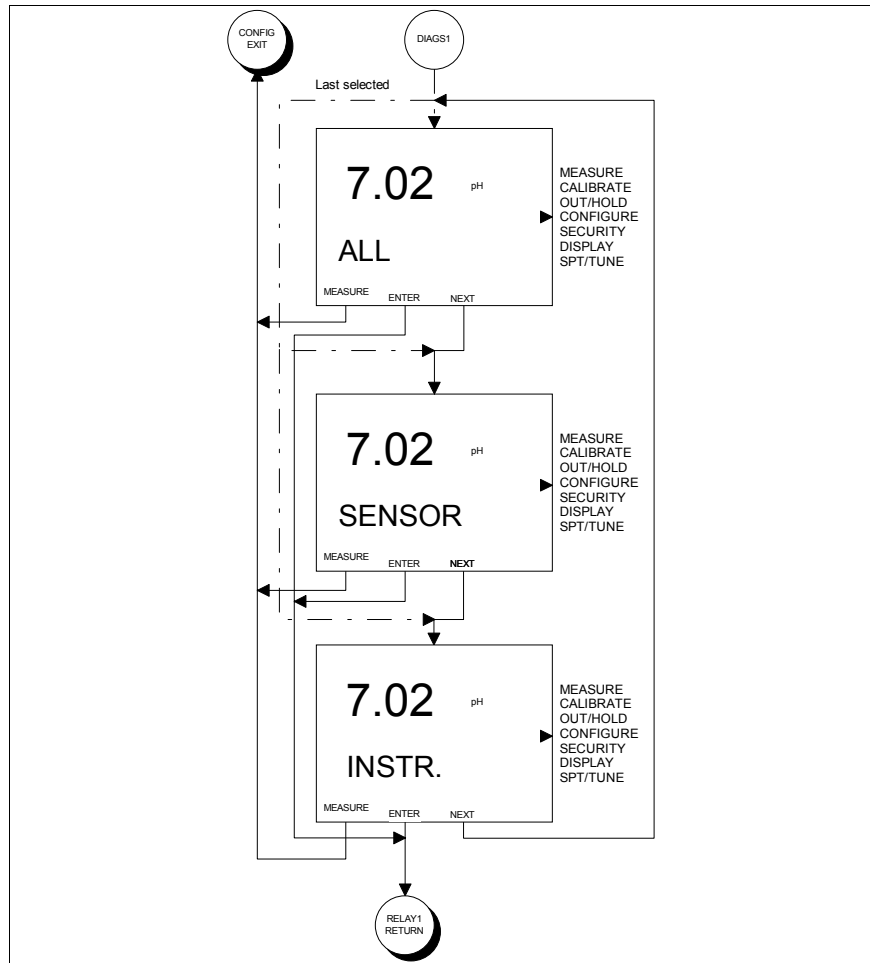

Figure 8-12. Screen Flow Diagram For Setting the Diagnostic Relay Output Configure State of Operation.

Cycle Timer Relay Output (Advanced)

A Cycle Timer can only be sourced to the Process Variable and can energize the relay for either a High or Low setpoint condition.

As with a Setpoint Relay Output, the Setpoint condition functions in the same manner; however, the Deadband control is replaced with

the Cycle Time. Thus, a Cycle Timer will energize the Relay Output for a set amount of time (ON.TIME) and de-energize for the remainder of the cycle (CYC.MIN). This cycle repeats until the Setpoint condition is no longer met. For more information on the Cycle Timer, see Section 2, Overview.

Valid Setpoint values are limited to the Process Variable range of the TB84PH Advantage Series analyzer. See Table 1-3, Specifications, for analyzer range values. Valid Cycle Time and On Time values are 0.0 to 99.9 minutes.

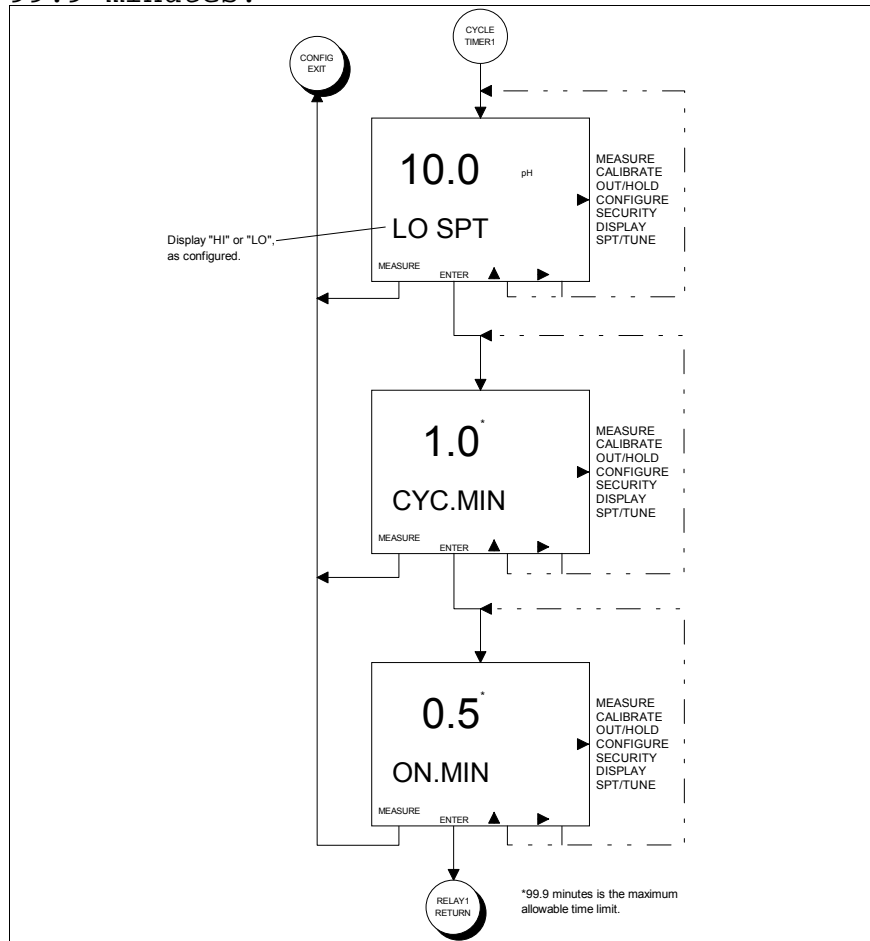

Figure 8-13. Screen Flow Diagram For Setting the Cycle Timer Relay Output Configure State. Set the Cycle Timer parameters of a Relay Output using Figure 8-13 as reference and the following procedure:

- 1) Set the Setpoint (i.e., LO SPT or HI SPT) using the ▲ Key to increment the blinking digit and the ► Key to move to

the next digit, and press the ENTER Key to enter the new value.

- 2) Set the Cycle Time in minutes (i.e., CYC.MIN) using the ▲ Key to increment the blinking digit and the ► Key to move to the next digit, and press the ENTER Key to enter the new value.
- 3) Set the On Time in minutes (i.e., ON.MIN) using the ▲ Key to increment the blinking digit and the ► Key to move to the next digit, and press the ENTER Key to enter the new value.

Cleaner Relay Output (Advanced)

Automatic sensor cleaning can be accomplished using any one of the three relay outputs. At a prescribed time interval, a Cleaner Relay Output will energize and allow the activation of a cleaning device. While in the energized state, analog and relay outputs can be held to values captured just prior to the cleaning cycle (i.e., energized state). If a relay hold condition is not feasible, non-cleaner relay outputs can be disable during a cleaning cycle.

To specify a cleaning cycle, the Cycle, On, and Recovery Times must be defined. The Cycle Time defines the repeating period between cleaning cycles, the On Time defines the length of time the relay will be energized, and the Recovery Time defines the length of time after the relay has been de-energized before the hold and/or disable condition(s) will be removed. Valid times for Cycle Time are 0.0 to 99.9 hours and for On and Recovery Times are 0.0 to 99.9 minutes.

Set the Cleaner parameters of a Relay Output using Figure 8-14 as reference and the following procedure:

- 1) Set the Cycle Time in hours (i.e., CYC.HRS) using the ▲ Key to increment the blinking digit and the ► Key to move to the next digit, and press the ENTER Key to enter the new value.
- 2) Set the On Time in minutes (i.e., ON.MIN) using the ▲ Key to increment the blinking digit and the ► Key to move to the next digit, and press the ENTER Key to enter the new value.
- 3) Set the Recovery Time in minutes (i.e., RCV.MIN) using the ▲ Key to increment the blinking digit and the ► Key to move to the next digit, and press the ENTER Key to enter the new value.
- 4) Hold the Analog Outputs (i.e., AO.HLD) during the On and Recovery Times using the YES Key, or leave the Analog Outputs live during the On and Recovery Times using the No Key.
- 5) Hold the Relay Outputs (i.e., RO.HLD) during the On and Recovery Times using the YES Key, or continue onto the Disable Relay Outputs State during the On and Recovery Times using the No Key.
- 6) Disable the Relay Outputs (i.e., RO.HLD) during the On and Recovery Times using the YES Key, or leave the Relay Outputs live during the On and Recovery Times using the No Key.

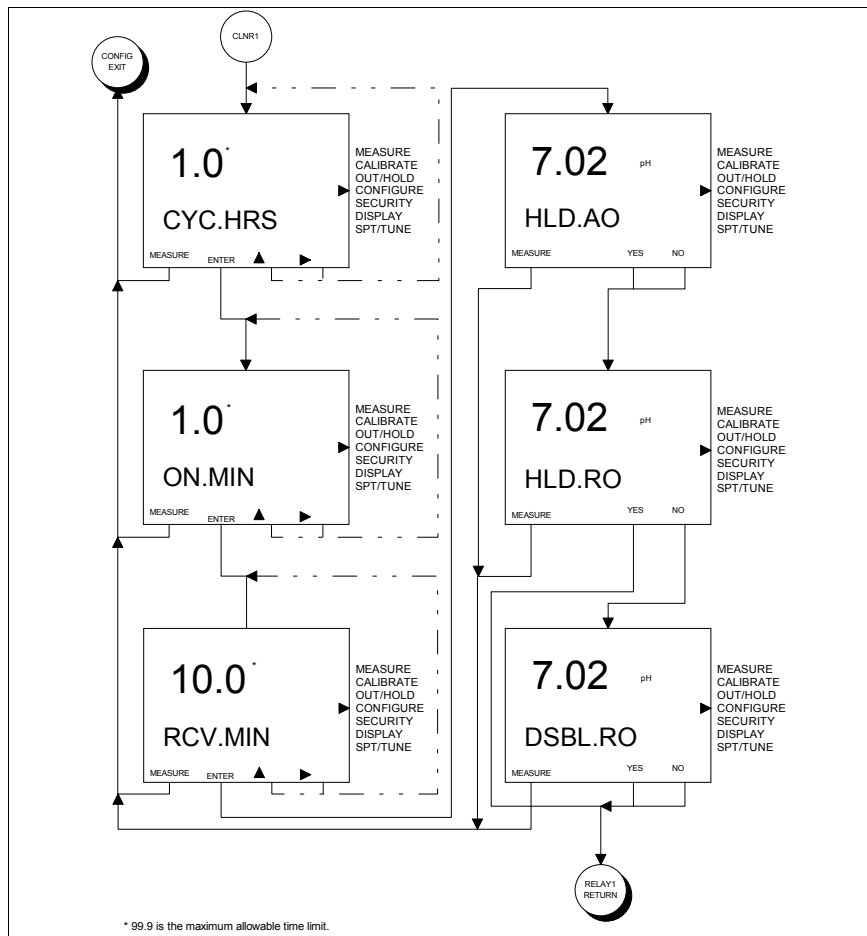

Figure 8-14. Screen Flow Diagram For Setting the Cleaner Relay Output Configure State of Operation.

The Damping State applies a lag function on the configured signals and reduces fluctuations caused by erratic process conditions. The damping value can be set from 0.0 to 99.9 seconds and represents the time required to reach 63.2% of a step change in the process variable.

For the Basic Programming Mode, the damping value can only be applied to the process variable input signal. The Advanced Programming Mode allows for separate damping of the Display Process Variable, Analog Output One, and Analog Output Two.

Set the Damping State using Figure 8-15 as a reference and the following procedure:

- 1) Select the DAMPNG State using the SELECT Key.

- 2) For Basic configurations, set the new damping value using the ▲ Key to increment the blinking digit and the ► Key to move to the next digit, and press the ENTER Key to enter the new value.
- 3) For Advanced configurations, set the new damping value for the Displayed Process Variable (i.e., DSP.SEC) using the ▲ Key to increment the blinking digit and the ► Key to move to the next digit, and press the ENTER Key to enter the new value.

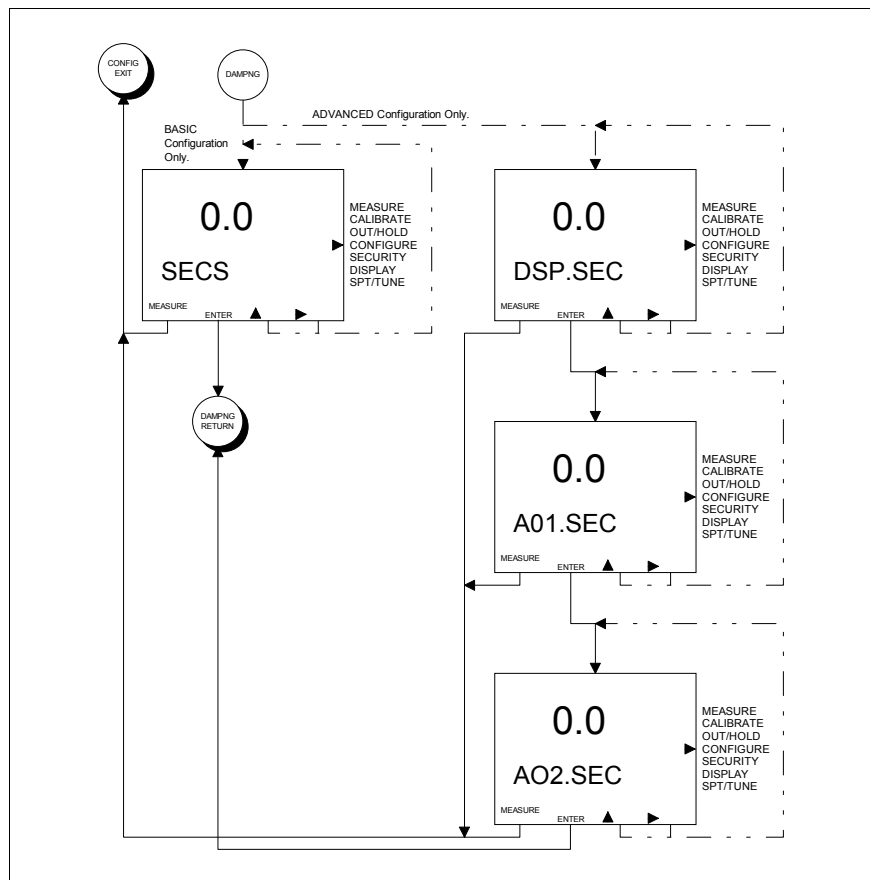

Figure 8-15. Screen Flow Diagram For Damping Configure State of Operation.

- 4) For Advanced configurations, set the new damping value for Analog Output One (i.e., A01.SEC) using the ▲ Key to increment the blinking digit and the ► Key to move to the next digit, and press the ENTER Key to enter the new value.
- 5) For Advanced configurations, set the new damping value for Analog Output Two

(i.e., AO2.SEC) using the ▲ Key to increment the blinking digit and the ► Key to move to the next digit, and press the ENTER Key to enter the new value.

Diagnostics State (Basic/Advanced)

The Diagnostics State allows the built-in sensor diagnostics to be disabled. When a sensor does not have a solution ground such as Non-Advantage (i.e., TB5) sensors, the diagnostic signal cannot be injected into process liquid. For these situations and applications that use very pure water, the sensor diagnostics should be disabled.

Set the DIAG (i.e., Diagnostics) State using the following procedure:

- 1) Select the DIAG State using the SELECT Key.
- 2) Toggle the diagnostics function to the desired state (i.e., OFF or ON) using the ▲ Key, and press the ENTER Key to enter the new value.

Safe Mode One State (Basic/Advanced)

The Safe Mode One State determines the Analog Output One level if an error condition occurs that renders the analyzer inoperable. The available states are FAIL.LO (i.e., fail low) or FAIL.HI (i.e., fail high). For more information on error conditions, see Section 13, Diagnostics.

Set the Safe Mode One State using the following procedure:

- 1) Select the SAF.MD.1 State using the SELECT Key.
- 2) Set the safe mode by using the NEXT Key to toggle between FAIL.LO and FAIL.HI, and use the ENTER Key to enter the new value.

Safe Mode Two State (Basic/Advanced)

The Safe Mode Two State determines the Analog Output Two level if an error condition occurs that renders the analyzer inoperable. The available states are FAIL.LO (i.e., fail low) and FAIL.HI (i.e., fail high). For more information on error conditions, see Section

13, Diagnostics.

Set the Safe Mode Two State using the following procedure:

- 1) Select the SAF.MD.2 State using the SELECT Key.
- 2) Set the safe mode by using the NEXT Key to toggle between FAIL.LO and FAIL.HI, and use the ENTER Key to enter the new value.

Spike State (Advanced)

The Spike State sets the diagnostic spike level as a percent of output. This level will determine the magnitude of the spike.

When the Spike has been set for any level greater than 0% and is enabled in the Spike Output State, the TB84PH Advantage Series analyzer will modulate the Analog Output One signal by the configured level for one second out of every six seconds when a problem condition is detected. Using this modulation, the analyzer informs the operator of a detected diagnostic condition. For more information on problem conditions, see Section 13, Diagnostics. For a description of the diagnostic spike feature, see Section 2, Analyzer Functionality And Operator Interface Controls.

Set the Spike State using the following procedure:

- 1) Select the SPIKE State using the SELECT Key.
- 2) Set the SPK.MAG (i.e., spike magnitude) using the ▲ Key to increment the blinking digit and the ► Key to move to the next digit, and press the ENTER Key to enter the new value. The Spike Magnitude is entered as a percentage of the 16 milliampere output range for a four to 20 milliampere output or 20 milliampere output range for a zero to 20 milliampere output (e.g., 10% will generate a 1.6 milliampere spike for a four to 20 milliampere output range).

Note: Once the Spike State is OFF, changing the configured spike level in the Configure Mode will not reenable the Spike State. The Spike State can only be turned ON or OFF in the

Output/Hold Mode of Operation.

CONFIGURATION LOCKOUT

The TB84PH Advantage Series analyzer has a lockout feature that, once engaged, prohibits access to the Configure Mode. This feature does not affect parameters that can be changed in the other modes of operation including Calibrate, Output/Hold, Security, secondary Display, and Setpoint/Tune.

To enable the lockout feature, change jumper W1 on the Microprocessor/Display PCB from pins 1 and 2 (i.e., position A - the factory default position) to pins 2 and 3 (i.e., position B).

Use Figure 8-16 and Section 16, Replacement Procedures, for jumper positions and circuit board handling procedures.

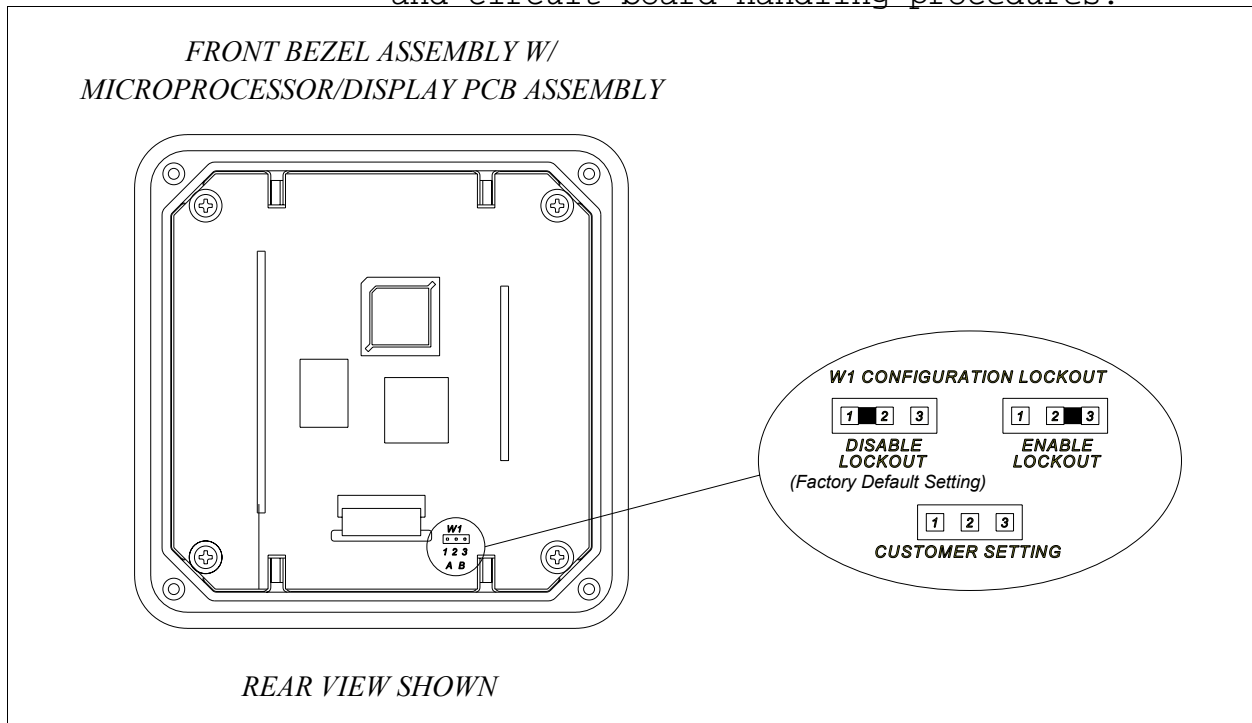

Figure 8-16. Configuration Lockout Jumper Location On Microprocessor/Display PCB Assembly.

SECTION 9 - SECURITY MODE

INTRODUCTION

The Security Mode of Operation establishes password protection against unauthorized changes to analyzer functions by unqualified personnel. Password protection can be assigned to the Calibrate, Output/Hold, Setpoint/Tune and Configure Modes of Operation.

SECURITY STATE OF OPERATION

The Security Mode of Operation provides password protection of critical operating environments. Each mode or state of operation that can be password protected is set by toggling the primary display between security OFF and ON using the ▲ Smart Key. As seen in Figure 9-1, all security assignments must be made before a password can be defined.

When one or more mode(s)/state has the security ON, the Security State will also be secured. One password assignment applies to all secured modes and states.

Set the Security State using Figure 9-1 as a reference and the following procedure:

- 1) Select the SECUR (i.e., Security) Mode of Operation using the SELECT Key.
- 2) Set the security for the CALIBR (i.e., Calibrate) Mode using the ▲ Key to toggle between ON and OFF, and press the ENTER Key to enter the new value.
- 3) Set the security for the OUTPUT (i.e., Output/Hold) Mode using the ▲ Key to toggle between ON and OFF, and press the ENTER Key to enter the new value.
- 4) Set the security for the CONFIG (i.e., Modify Configure) State using the ▲ Key to toggle between ON and OFF, and press the ENTER Key to enter the new value.

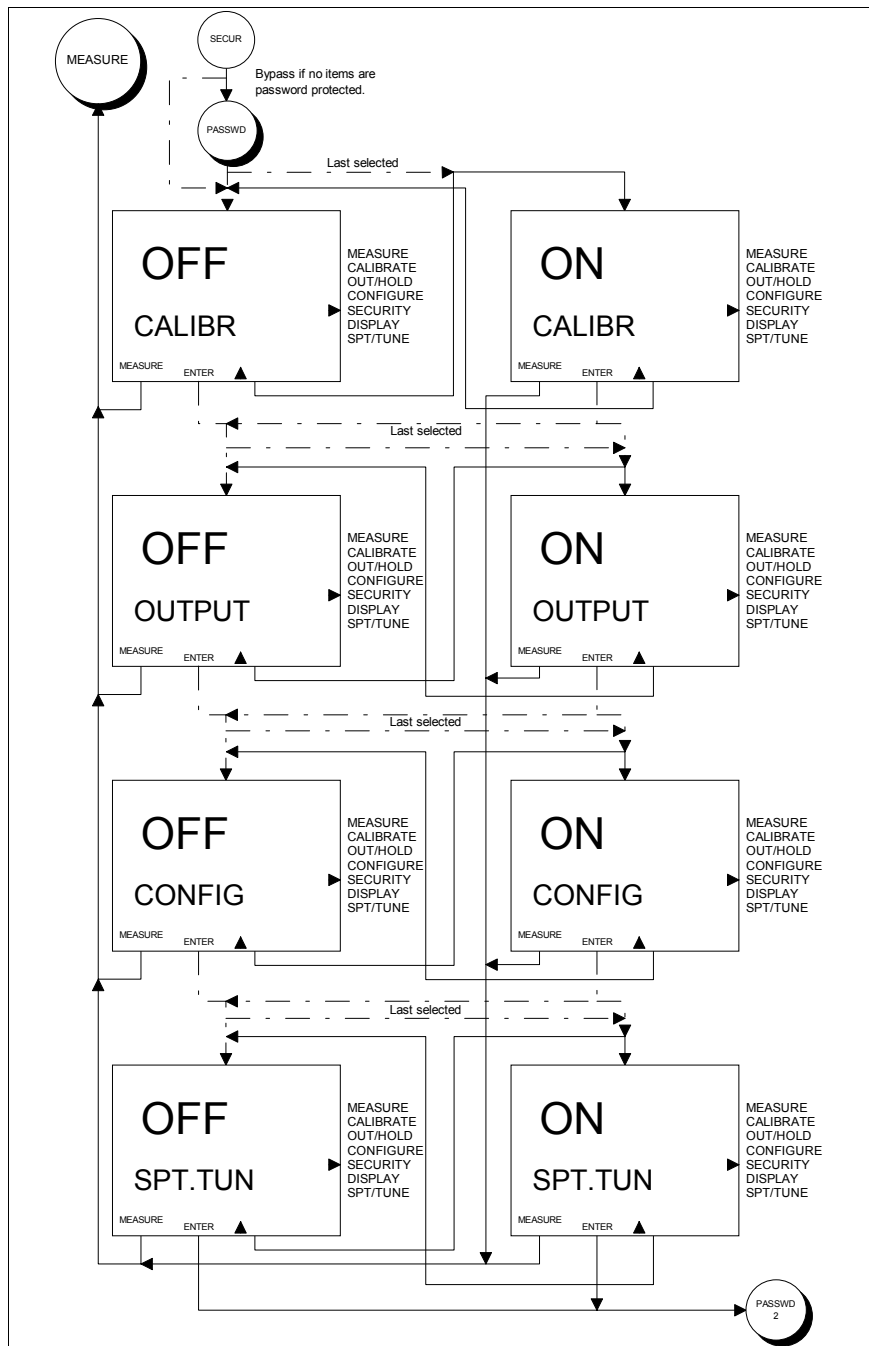

Figure 9-1. Screen Flow Diagram For Security State of Operation.

- 5) Set the security for the SPT.TUN (i.e., Setpoint/Tune) Mode using the ▲ Key to toggle between ON and OFF, and press the ENTER Key to enter the new value.

-
- 6) Define the password for all secured modes and states using the ▲ Key to increment the blinking digit and the ► Key to move to the next digit, and press the ENTER Key to enter the password.

Note: The password must be defined as three digits and verified to enable security on the modes/states entered in steps 2 through 4. If security is not ON for any of the modes/states, the password state will be bypassed.

- 6) Verify the password using the ▲ Key to increment the blinking digit and the ► Key to move to the next digit, and press the ENTER Key to enter the password.

Remove all security using the following procedure:

- 1) Select the SECUR Mode of Operation using the SELECT Key.
- 2) Enter the password for all secured modes and states using the ▲ Key to increment the blinking digit and the ► Key to move to the next digit, and press the ENTER Key to submit the password.
- 3) Set the security for the CALIBR (i.e., Calibrate) Mode by pressing the ▲ Key to toggle the display to OFF, and press the ENTER Key to enter the value.
- 4) Set the security for the OUTPUT (i.e., Output/Hold) Mode by pressing the ▲ Key to toggle the display to OFF, and press the ENTER Key to enter the value.
- 5) Set the security for the CONFIG (i.e., Modify Configure) State by pressing the ▲ Key to toggle the display to OFF, and press the ENTER Key to enter the value.
- 6) Set the security for the SPT.TUN (i.e., Setpoint/Tune) Mode by pressing the ▲ Key to toggle the display to OFF, and press the ENTER Key to enter the value.

Change the password or security state using the following procedure:

- 1) Select the SECUR Mode of Operation using the SELECT Key.
- 2) Enter the password for all secured modes and states using the ▲ Key to increment the blinking digit and the ► Key to move to the next digit, and press the ENTER Key to submit the password.
- 3) Leave the security state unchanged for CALIBR (i.e., Calibrate) Mode by using the ENTER Key Set, or if needed, change the security state for CALIBR (i.e., Calibrate) using the ▲ Key. Press the ENTER Key to enter the new value.
- 4) Leave the security state unchanged for OUTPUT (i.e., Output/Hold) Mode by using the ENTER Key Set, or if needed, change the security state for OUTPUT using the ▲ Key. Press the ENTER Key to enter the new value.
- 5) Leave the security state unchanged for CONFIG (i.e., Modify Configure) State by using the ENTER Key Set, or if needed, change the security state for CONFIG (i.e., Modify Configure) using the ▲ Key. Press the ENTER Key to enter the new value.
- 6) Leave the security state unchanged for SPT.TUN (i.e., Setpoint/Tune) Mode by using the ENTER Key Set, or if needed, change the security state for SPT.TUN (i.e., Setpoint/Tune) using the ▲ Key. Press the ENTER Key to enter the new value.
- 7) Change the password for all secured modes and states using the ▲ Key to increment the blinking digit and the ► Key to move to the next digit, and press the ENTER Key to enter the password.

-
- 8) Verify the new password using the ▲ Key to increment the blinking digit and the ► Key to move to the next digit, and press the ENTER Key to enter the password.

Note: If the password was not changed, the verification of the old password will not be required.

If the password is lost, the security can be removed using the Reset Password State of Operation. To reset the password, see Section 11, Utility Mode.

SECTION 10 - SECONDARY DISPLAY MODE

INTRODUCTION

The TB84PH Advantage Series analyzer has two display regions. In the Measure Mode of Operation, the primary display region shows the measured process variable, and the secondary display region can show a multitude of process, sensor, or analyzer information. This information can be viewed or set as the displayed value when in the Measure Mode of Operation.

SECONDARY DISPLAY STATE OF OPERATION

The Secondary Display Mode of Operation contains seven states of operation that provide information on the process temperature, output current values, sensor output, software revision, and spike status. As seen in Figure 10-1, each Secondary Display State can be sequentially viewed by using the NEXT Smart Key. To have any given Secondary Display State be continually shown in the Measure Mode, press the ENTER Smart Key while the desired state is displayed. The TB84PH Advantage Series analyzer will proceed to the Measure Mode and display the entered Secondary Display State in the secondary display region.

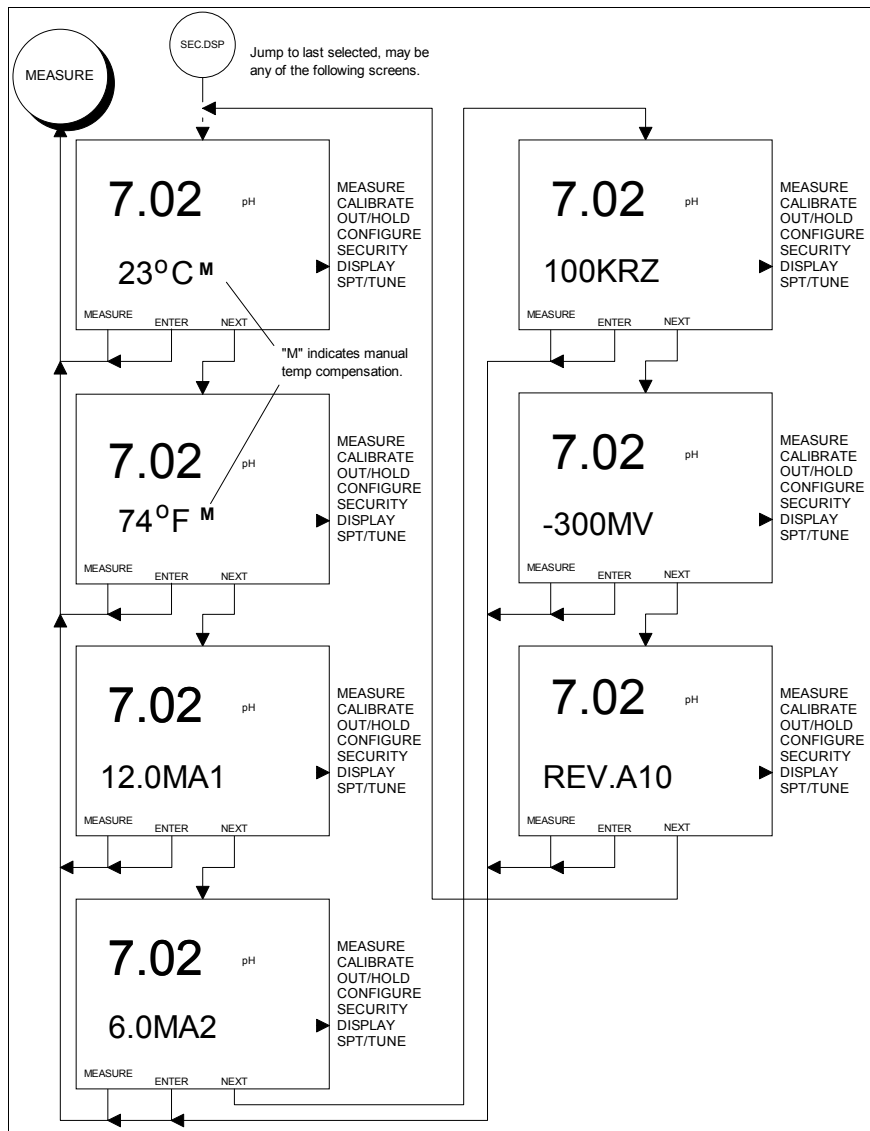

Figure 10-1. Screen Flow Diagram For Secondary Display States of Operation.

SECTION 11 - SETPOINT/TUNE MODE

INTRODUCTION

The Setpoint/Tune Mode of Operation provides a direct method to tune relay output parameters. Though this mode of operation can not be used to change the function a relay, it does provide the ability to change relay parameters pertinent to process control. To change the relay output function, see Section 8, Configure Mode.

SETPOINT/TUNE STATES OF OPERATION

The Setpoint/Tune Mode consists of three states of operation: RELAY1, RELAY2, and RELAY3. Each state provides the ability to update operational parameters for the configured relay functions. For instead if Relay Output One is configured to function as a High Process Variable Setpoint, the Setpoint, Deadband, and Time Delay will be tunable parameters available in the Setpoint/Tune Relay One State of Operation.

Since the tunable parameters are dependent on the configured relay function, the following sections will only describe the adjustment of these parameters.

Setpoint Relay Output (Basic/Advanced)

A Setpoint Relay Output can be configured to energize when the Process Variable or Temperature exceeds (i.e., a High Setpoint) or falls below (i.e., a Low Setpoint) a defined level. Valid Setpoint values are limited to the Process Variable and/or Temperature range of the TB84PH Advantage Series analyzer. See Table 1-3, Specifications, for analyzer range values.

To prevent relay chatter, a Setpoint Relay Output has an configurable Deadband. The Deadband control keeps the relay energized until the Process Variable or Temperature has decreased below a High Setpoint value or above a Low Setpoint value by the Deadband value. Valid Deadband values are 0.00 to 10.00 pH for pH, 0 to 200 mV for ORP and pION, 0 to 10% of the END.MAG (i.e., End Magnitude) for Ion Concentration Process Variable sources and 0 to 10°C (18°F) for Temperature sources.

A Time Delay control also refines the function of a Setpoint Relay. Entering a Time Delay value greater than 0.0 minutes enables a waiting period before energizing the relay once the setpoint condition has been met. Valid Time Delay values are 0.0 to 99.9 minutes.

Set the Setpoint parameters of a Relay Output using Figure 8-11 as a reference and the following procedure:

- 1) Set the Setpoint (i.e., LO SPT or HI SPT) using the ▲ Key to increment the blinking digit and the ► Key to move to the next digit, and press the ENTER Key to enter the new value.
- 2) Set the Deadband (i.e., DBAND) using the ▲ Key to increment the blinking digit and the ► Key to move to the next digit and, press the ENTER Key to enter the new value.
- 3) Set the Time Delay in minutes (i.e., DLY.MIN) using the ▲ Key to increment the blinking digit and the ► Key to move to the next digit, and press the ENTER Key to enter the new value.

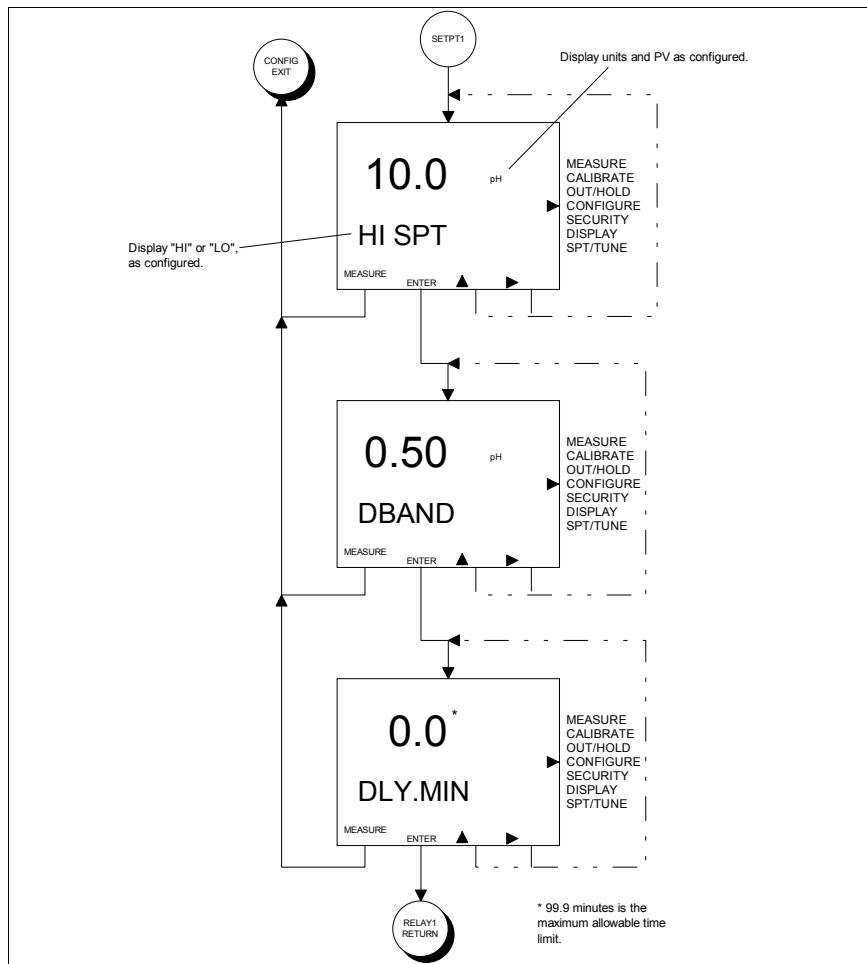

Figure 8-11. Screen Flow Diagram For Setting the Setpoint Relay Output Configure State of Operation.

Diagnostic Relay Output (Basic/Advanced)

A Diagnostic Relay Output simply energizes when a diagnostic condition has been detected. The relay can be configured to trigger on a sensor, instrument, or all diagnostic conditions.

Set the trigger for the Diagnostic Relay Output using Figure 8-12 as reference and the following procedure:

- 1) Set the Diagnostic trigger using the NEXT Key to toggle between ALL, SENSOR, and INSTR. (i.e., Instrument), and press the ENTER Key to enter the new trigger.

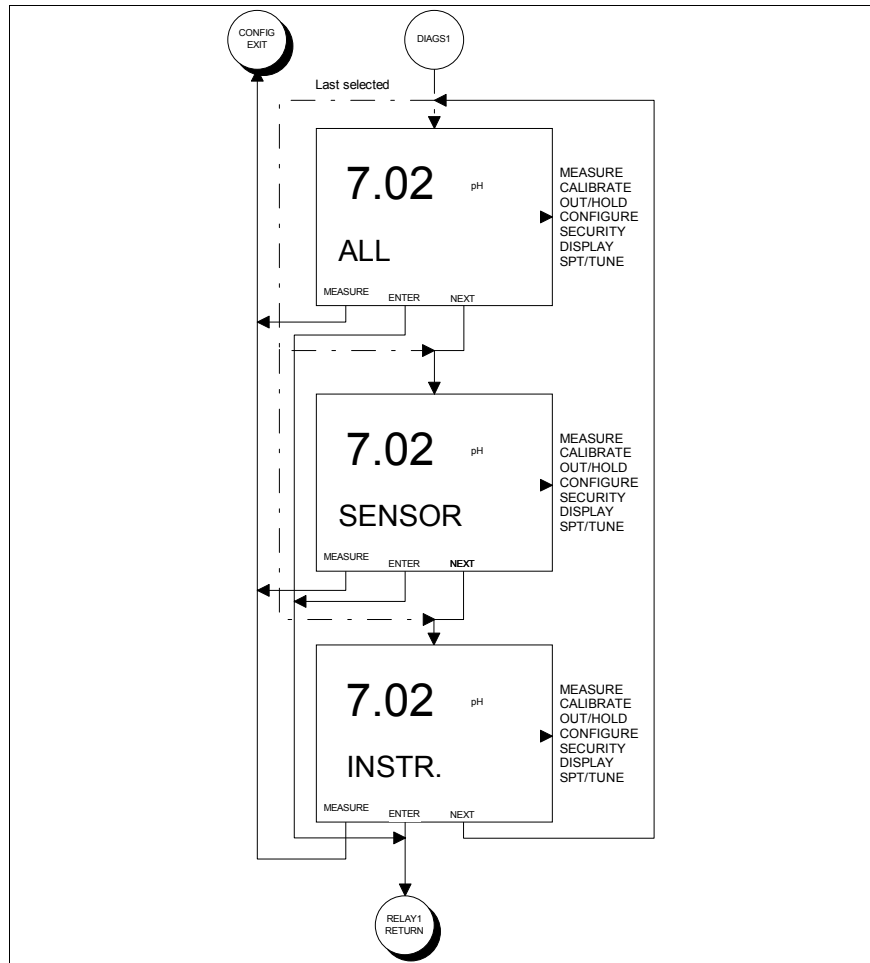

Figure 8-12. Screen Flow Diagram For Setting the Diagnostic Relay Output Configure State of Operation.

Cycle Timer Relay Output (Advanced)

A Cycle Timer can only be sourced to the Process Variable and can energize the relay for either a High or Low setpoint condition.

As with a Setpoint Relay Output, the Setpoint condition functions in the same manner; however, the Deadband control is replaced with the Cycle Time. Thus, a Cycle Timer will energize the Relay Output for a set amount of time (ON.TIME) and de-energize for the remainder of the cycle (CYC.MIN). This cycle repeats until the Setpoint condition is no longer met. For more information on the Cycle Timer, see Section 2, Overview.

Valid Setpoint values are limited to the Process Variable range of the TB84PH Advantage Series analyzer. See Table 1-3, Specifications, for analyzer range values. Valid Cycle Time and On Time values are 0.0 to 99.9 minutes.

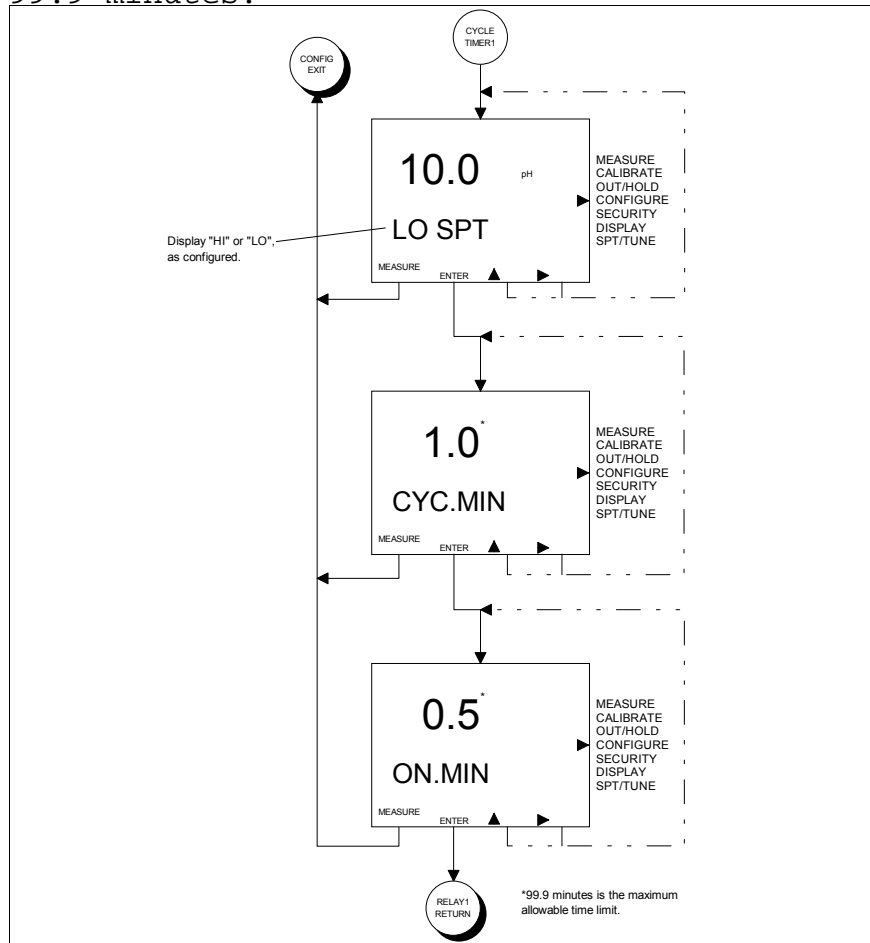

Figure 8-13. Screen Flow Diagram For Setting the Cycle Timer Relay Output Configure State of Operation. Set the cycle timer parameters of a Relay Output using Figure 8-13 as reference and the following procedure:

-
- 1) Set the Setpoint (i.e., LO SPT or HI SPT) using the ▲ Key to increment the blinking digit and the ► Key to move to the next digit, and press the ENTER Key to enter the new value.
 - 2) Set the Cycle Time in minutes (i.e., CYC.MIN) using the ▲ Key to increment the blinking digit and the ► Key to move to the next digit, and press the ENTER Key to enter the new value.
 - 3) Set the On Time in minutes (i.e., ON.MIN) using the ▲ Key to increment the blinking digit and the ► Key to move to the next digit, and press the ENTER Key to enter the new value.

Cleaner Relay Output (Advanced)

Automatic sensor cleaning can be accomplished using any one of the three relay outputs. At a prescribed time interval, a Cleaner Relay Output will energize and allow the activation of a cleaning device. While in the energized state, analog and relay outputs can be held to values captured just prior to the cleaning cycle (i.e., energized state). If a relay hold condition is not feasible, non-cleaner relay outputs can be disabled during a cleaning cycle.

To specify a cleaning cycle, the Cycle, On, and Recovery Times must be defined. The Cycle Time defines the repeating period between cleaning cycles, the On Time defines the length of time the relay will be energized, and the Recovery Time defines the length of time after the relay has been de-energized before the hold and/or disable condition(s) will be removed. Valid times for Cycle Time are 0.0 to 99.9 hours and for On and Recovery Times are 0.0 to 99.9 minutes.

Set the Cleaner parameters of a Relay Output using Figure 8-14 as reference and the following procedure:

- 1) Set the Cycle Time in hours (i.e., CYC.HRS) using the ▲ Key to increment the blinking digit and the ► Key to move to the next digit, and press the ENTER Key to enter the new value.
- 2) Set the On Time in minutes (i.e., ON.MIN) using the ▲ Key to increment the blinking digit and the ► Key to move to the next digit, and press the ENTER Key to enter the new value.
- 3) Set the Recovery Time in minutes (i.e., RCV.MIN) using the ▲ Key to increment the blinking digit and the ► Key to move to the next digit, and press the ENTER Key to enter the new value.
- 4) Hold the Analog Outputs (i.e., AO.HLD) during the On and Recovery Times using the YES Key, or leave the Analog Outputs live during the On and Recovery Times using the No Key.
- 5) Hold the Relay Outputs (i.e., RO.HLD) during the On and Recovery Times using the YES Key, or continue onto the Disable Relay Outputs State during the On and Recovery Times using the No Key.
- 6) Disable the Relay Outputs (i.e., RO.HLD) during the On and Recovery Times using the YES Key, or leave the Relay Outputs live during the On and Recovery Times using the No Key.

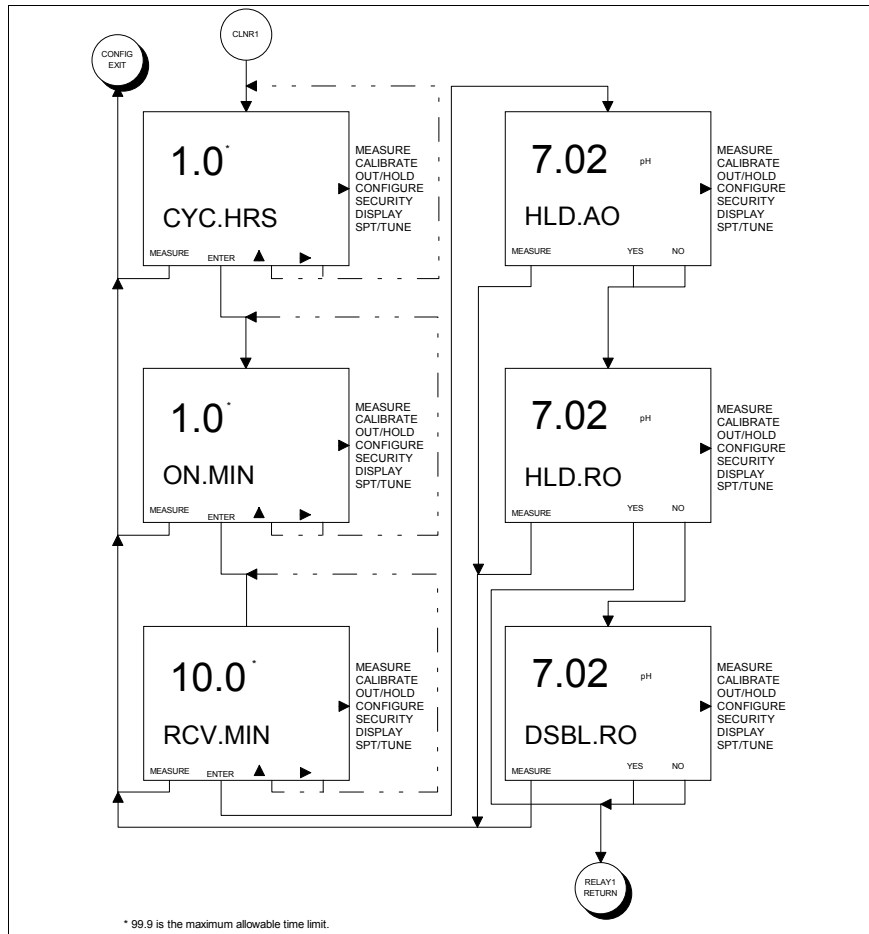

Figure 8-14. Screen Flow Diagram For Setting the Cleaner Relay Output Configure State of Operation.

SECTION 12 - UTILITY MODE

INTRODUCTION

The TB84PH Advantage Series analyzer contains a Utility Mode of Operation that provides access to powerful functions not used during normal operating conditions. These functions have been separated into two categories: Factory and User. Factory functions are strictly reserved for ABB personnel.

User functions include Programming Mode, reset configuration to default settings, remove security, reset all parameters to default settings, and software reboot functions.

FACTORY/USER STATE

The Factory and User States of Operation can be accessed using the hidden fifth key located directly above the NT in the ADVANTAGE text on the keypad. Once the hidden key has been pressed, the textual prompt USER will be displayed in the secondary display region. Pressing the SELECT Smart Key brings the user into the User State, pressing the NEXT Smart Key brings the user to the Factory selection, and pressing the Exit to MEASURE Smart Key escapes back to the Measure Mode.

User State

The User State contains the primary toggle for setting the Programming Mode, three reset functions, and a software reboot operation that initiates a self-test mode. Table 12-1 describes the function of each User State.

The NEXT Smart Key sequentially moves through each of the four User States. This cycle repeats until a state is selected or the escape function is chosen using the Exit to MEASURE Smart Key. To select a state, press the SELECT Smart Key when the desired User State is shown in the secondary display region.

Table 12-1. User States

State	Function
MODE	Sets the Programming Mode that are available in the Modify Configure State of Operation.
RST.CON	Resets the configuration to factory default settings.
RST.SEC	Resets the security password and removes all security.
RST.ALL	Resets all programming parameters such as configuration, calibration, output/hold, security, secondary display, and setpoint/tune functions to factory default settings.
RST.SFT	Resets the analyzer by repeating the boot-up and self-test procedures.

Figure 12-1 identifies the Smart Key assignments and resulting action. The following section describes each of the User States and their applicability.

Advanced/Basic Programming Mode User State

In order to simplify the configuration process for a user who only needs a limited amount of functionality, the TB84PH Advantage Series analyzer contains two types of Programming Modes: Basic and Advanced. The Programming Mode is defined by a nomenclature option.

The Basic Programming Mode contains a reduced set of features found in the Advanced Programming Mode. Reducing the available features helps streamline the configuration process. If the TB84PH Advantage Series analyzer is ordered with Advanced Programming, the Basic or Advanced Programming Mode can be used.

Contact ABB for information on Advanced Programming upgrades.

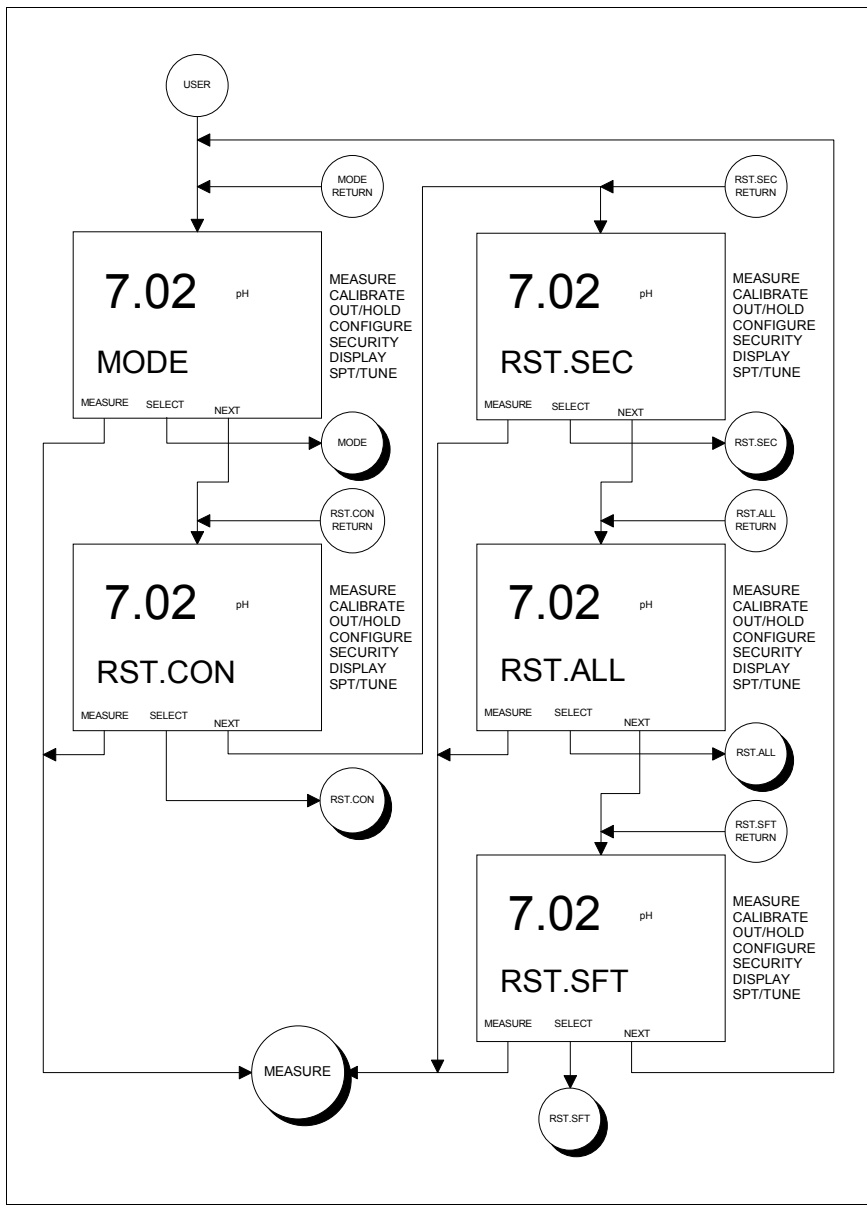

Figure 12-1. Screen Flow Diagram For User States of Operation.
Reset Configuration User State

The Reset Configuration User State returns the configuration to factory default settings. See the Preface or Appendix C, Configuration Worksheets, for software default settings.

To reset the configuration to factory defaults, use the following procedure:

- 1) Access the User Mode by pressing the hidden button located directly above the NT in the ADVANTAGE text on the keypad. The text USER will appear in the secondary display once the hidden button has been pressed.
- 2) Press the SELECT Key to access the User Mode. The text MODE will appear in the secondary display.
- 3) Press the NEXT Key to display RST.CON (i.e., Reset Configuration) text.
- 4) Press the SELECT Key to reset the configuration.
- 5) Enter the security password (if the Configure Mode has been secured) using the ▲ Key to increment the blinking digit and the ► Key to move to the next digit, and press the ENTER Key to enter the password.
- 6) Confirm the reset operation when the text RESET? is displayed by pressing the YES Key, or abort the reset operation by pressing the NO Key.

Reset Security User State

The Reset Security User State returns the security to factory default settings. The factory default is security OFF for all applicable modes and states (i.e., Calibrate, Output/Hold, Modify Configure, and Setpoint/Tune).

To remove the security, use the following procedure:

- 1) Access the User Mode by pressing the hidden button located directly above the NT in the ADVANTAGE text on the keypad. The text USER will appear in the secondary display once the hidden button has been pressed.
- 2) Press the SELECT Key to access the User Mode. The text MODE will appear in the secondary display.
- 3) Press the NEXT Key until the secondary display region shows RST.SEC (i.e., Reset Security) text.
- 4) Press the SELECT Key to reset the security.
- 5) Enter the security password **732** using the ▲ Key to increment the blinking digit and the ► Key to move to the next digit, and press the ENTER Key to enter the password.
- 6) Confirm the reset operation when the text RESET? is displayed by pressing the YES Key, or abort the reset operation by pressing the NO Key.

Reset All User State

The Reset All User State returns all analyzer parameters back to factory defaults. This includes calibration, output/hold, configuration, security, secondary display, and setpoint/tune values.

To reset all analyzer parameters, use the following procedure:

- 1) Access the User Mode by pressing the hidden button located directly above the NT in the ADVANTAGE text on the keypad. The text USER will appear in the secondary display once the hidden button has been pressed.
- 2) Press the SELECT Key to access the User Mode. The text MODE will appear in the secondary display.
- 3) Press the NEXT Key until the secondary display region shows RST.ALL (i.e., Reset

ALL) text.

- 4) Press the SELECT Key to reset all analyzer parameters.
- 5) Enter the security password **255** using the ▲ Key to increment the blinking digit and the ► Key to move to the next digit, and press the ENTER Key to enter the password.
- 6) Confirm the reset operation when the text RESET? is displayed by pressing the YES Key, or abort the reset operation by pressing the NO Key.

Soft Boot User State

The Soft Boot User State initiates a software reset. The software reset initiates boot-up and self-test procedures. All programmable instrument parameters are unaffected by this function.

To reboot the analyzer without affecting any instrument parameters, use the following procedure:

- 1) Access the User Mode by pressing the hidden button located directly above the NT in the ADVANTAGE text on the keypad. The text USER will appear in the secondary display once the hidden button has been pressed.
- 2) Press the SELECT Key to access the User Mode. The text MODE will appear in the secondary display.
- 3) Press the NEXT Key until the secondary display region shows RST.SFT (i.e., Reset ALL) text.

-
- 4) Press the SELECT Key to initiate the reboot operation.
 - 5) Confirm the reboot operation when the text RESET? is displayed by pressing the YES Key, or abort the reset operation by pressing the NO Key.

SECTION 13 - DIAGNOSTICS

INTRODUCTION

The TB84PH Advantage Series analyzer performs a number of diagnostic checks on hardware, software, and sensor functions. If a nonconforming condition is detected, the user is alerted to faults locally by a flashing FAULT indicating icon and, if configured, remotely by modulating Analog Output One (i.e., Spike Output) and/or energizing a Relay Output (i.e., Diagnostic Relay Output).

Diagnostic faults are interrogated using the FAULT Info Smart Key. A short text string and fault code are alternately shown in the secondary display region. If multiple faults exist, the FAULT Info Smart Key moves the user to the next fault. Once all faults have been interrogated, the analyzer returns to the Measure Mode of Operation.

The following section describes the types of fault conditions and their applicability to the TB84PH Advantage Series functionality.

FAULT CODES

Fault conditions are grouped into two categories based on severity. Conditions that result in degradation of analyzer performance are reported as Problem Codes (PC), while conditions that render the analyzer inoperable are reported as Error Codes (EC).

Fault codes are reported in the secondary display region in a first in, first out order (i.e., the first detected fault condition is the first condition that is displayed upon interrogation). All active fault conditions can be viewed at any time while in the Measure Mode using the FAULT Info Smart Key. A flashing Fault icon indicates a new fault condition that has not been interrogated. A non-flashing Fault icon indicates all fault conditions have been interrogated but not resolved. When all fault conditions are resolved, the Fault icon and FAULT Info Smart Key are de-energized.

Problem Codes

Problem Codes result from fault conditions that impact the performance of the TB84PH Advantage Series analyzer. In most cases, these conditions can be resolved by the user using standard practices.

The occurrence of a Problem Code fault condition triggers the Fault icon to energize, the Spike output to modulate (if configured), and a Diagnostic Relay Output to energize (if configured). These diagnostic indicators provide local and remote reporting capability.

Tables 13-1 and 13-2 contain all the Problem Codes supported by the TB84PH Advantage Series analyzer. Each entry lists the Problem Code number, displayed text string, and a short description of the fault. See Section 14, Troubleshooting, for resolving a fault condition.

Table 13-1. Common Problem Code Definitions

Problem Codes	Text String	Description
PC1	LO.GLS.Z	Low pH measuring electrode impedance.
PC2	HI.REF.Z	High reference electrode impedance.
PC4	GND LP	Ground Loop present or shorted sensor cable.
PC5	OPEN	Open sensor cable or sensor out of solution.
PC6	HI.AO1	Analog Output One above upper range value (+0.4 mA Hystersis).
PC7	LO.AO1	Analog Output One below lower range value (-0.2 mA Hystersis). Fault only applicable for 4-20 mA configurations.
PC8	HI.PV	Process Variable above analyzer range.
PC9	LO.PV	Process Variable below analyzer range.
PC10	HI.TEMP	Temperature above analyzer range.
PC11	LO.TEMP	Temperature below analyzer range.
PC12	HI.T.AD	Open or missing temperature sensor.
PC13	LO.T.AD	Shorted temperature sensor.
PC14	+HI.OFF	Large positive sensor offset (greater than 180 mV).
PC15	-HI.OFF	Large negative sensor offset (less than -180 mV).
PC16	HI.EFF	High sensor efficiency (greater than 110%).
PC17	LO.EFF	Low sensor efficiency (less than 60%).
PC18	HI.AO2	Analog Output Two above upper range value (+0.4 mA Hystersis).
PC19	LO.AO2	Analog Output Two below lower range value (+0.4 mA Hystersis). Fault only applicable for 4-20 mA configurations.

Table 13-2. Uncommon Problem Code Definitions

Problem Codes	Text String	Description
PC20	BAD.SEE	Bad Serial EEPROM or pH/ORP/pION Input PCB Assembly.

Problem Codes	Text String	Description
PC21	NO.F.CAL	Missing factory calibration and functional Serial EEPROM.
PC22	BLNK.uP	Blank microprocessor EEPROM.
PC23	SEE.EMI	Unverifiable SEEPROM bus read operation.
PC24	ROM.EMI	Unverifiable EEPROM/ROM bus read operation.
PC25	ROM.SUM	Incorrect EPROM Checksum.
PC30	PV.F.CAL	Out of range or missing factory calibration for the Process Variable.
PC31	BA.F.CAL	Out of range or missing factory calibration for 3k Balco temperature sensor.
PC32	PT.F.CAL	Out of range or missing factory calibration for Pt100 temperature sensor.
PC33	RZ.F.CAL	Out of range or missing factory calibration for reference impedance measurement.
PC34	PV.CHKS	Incorrect or missing Process Variable checksum.
PC35	BA.CHKS	Incorrect or missing 3k Balco temperature sensor checksum.
PC36	PT.CHKS	Incorrect or missing Pt100 temperature sensor checksum.
PC37	PZ.CHKS	Incorrect or missing reference impedance measurement checksum.
PC40	HI.R.CKT	Reference impedance circuit failure - High range error.
PC41	LO.R.CKT	Reference impedance circuit failure - Low range error.
PC42	HI.RZ.AD	Reference impedance above analyzer A/D range.
PC43	LO.RZ.AD	Reference impedance below analyzer A/D range.
PC44	HI.G.CKT	pH measuring electrode impedance circuit failure - High range error.
PC45	LO.G.CKT	pH measuring electrode impedance circuit failure - Low range error.
PC46	HI.GL.AD	pH measuring electrode impedance above analyzer A/D range.
PC47	LO.GL.AD	pH measuring electrode impedance below analyzer A/D range.
PC48	HI.C.CKT	Cable diagnostic circuit failure - High range error.
PC49	LO.C.CKT	Cable diagnostic circuit failure - Low range error.
PC50	HI.CA.AD	Cable diagnostic signal above analyzer A/D range.
PC51	LO.CA.AD	Cable diagnostic signal below analyzer A/D range.

Error Codes

Error Codes result from fault conditions that render the TB84PH Advantage Series analyzer inoperable. In most cases, these conditions can not be resolved by the user using standard methods.

The occurrence of an Error Code fault

condition triggers the Fault icon to energize and the Safe Mode outputs to enable (i.e., the Analog Output One and Two currents are fixed high or low based on the configured Safe Mode levels). These diagnostic indicators provide local and remote reporting capability.

Table 13-3 contains all the Error Codes supported by the TB84PH Advantage Series analyzer. Each entry lists the Error Code number, displayed text string, and a short description of the fault condition. See Section 14, Troubleshooting, for resolving a fault condition.

Table 13-3. Error Code Definitions

Error Codes	Text String	Description
EC1	HI.PV.AD	Over range Process Variable A/D.
EC2	LO.PV.AD	Under range Process Variable A/D.
EC4	TC.PCB	Toroidal conductivity board with pH/ORP/pION firmware.
EC5	DO.PCB	Dissolved Oxygen board with pH/ORP/pION firmware.
EC6	TE.PCB	Two-electrode conductivity board with pH/ORP/pION firmware.
EC7	EC.PCB	Four-electrode conductivity board with pH/ORP/pION firmware.

Calibration Diagnostic Messages

The TB84PH Advantage Series analyzer performs automatic efficiency and offset calculations relative to a theoretically perfect electrochemical and/or temperature sensor during each calibration cycle. Calibration history is retained for future interrogation using the Edit Calibrate State. The calibration constants that are displayed are Efficiency and Offset for the Process Variable and Slope and Offset for the Temperature.

An Efficiency of less than 60% or greater than 110% indicates a potentially bad process calibration point or poor performing sensor. Calibration values that yield Efficiency values less than 40% or greater than 150% are not accepted. In these cases, the text string BAD.CAL (i.e., bad calibration) is displayed in the secondary display region. The user is returned to the beginning of the calibration cycle after the bad calibration has been reported.

An Offset value of less than -180.0 mV or greater than +180 mV also indicates a potentially bad process calibration or poor performing sensor. Calibration values that yield Offset values less than -1000 mV or greater than +1000 mV are not accepted. Again, a bad calibration will be reported, and the user returned to the beginning of the calibration cycle.

For temperature, a bad calibration will be reported and calibration values will not be accepted for Slope values that are less than 0.2 or greater than 1.5 and Offset values that are less than -40°C or greater than +40 C. Temperature calibrations use smart software routines that automatically adjust the Slope, Offset, or both values based on the calibration value being entered and calibration history if it exists.

Additional Diagnostic Messages

Other diagnostic messages may appear during analyzer programming. These messages include BAD.VAL (i.e., bad value) and DENIED.

BAD.VAL indicates the attempted numeric entry of a value which is out of the allowed analyzer range. See Table 1-3, Specifications, for analyzer range limits.

DENIED indicates incorrect entry of a security password. See Section 9, Security Mode, for information on the Security Mode of Operation.

RAM.ERR indicates a Random Access Memory read/write error. The analyzer will automatically reset when this error has been encountered. If the analyzer continues to reset, contact ABB for problem resolution.

SECTION 14 - TROUBLESHOOTING

INTRODUCTION

This section provides troubleshooting information for the TB84PH Advantage Series analyzer and associated sensor. Using Table 14-1, problem and error conditions can be identified and the corrective action for these conditions can be tested. Refer to Section 13, Diagnostics, for descriptions of problem and error code conditions.

ANALYZER TROUBLESHOOTING

Table 14-1. Analyzer Troubleshooting Guide

Problem Code	Problem Text String	Corrective Action
PC1	LO.GLS.Z	<ol style="list-style-type: none">1) Verify sensor wiring is properly connected.2) Verify glass electrode is intact. Replace sensor if glass electrode is broken.3) Remove any liquids, oils, scales or corrosion from TB84PH terminal block or extension cable junction box terminals. Replace extension cable if corrosion is present.4) Verify sensor responds to pH buffers. Replace sensor if sensor does not respond.5) Change configuration to proper analyzer type if sensor is not a glass pH sensor.
PC2	HI.REF.Z	<ol style="list-style-type: none">1) Verify sensor wiring is properly connected.2) Verify reference is clean. Remove any foreign material. See Section 14, Maintenance.3) Clean sensor then verify sensor responds to pH buffers. Replace sensor if sensor does not respond.4) Change configuration to increase reference impedance limit if sensor is functioning properly in buffers and in the final installed location.
PC4	GND LP	<ol style="list-style-type: none">1) Verify sensor wiring is properly connected.2) Verify sensor does not have any exposed wires from nicks or equivalent. Repair if possible or replace.3) Remove any liquids, oils, scales or corrosion from TB84PH terminal block or extension cable junction box terminals. Replace extension cable if corrosion is present.4) Verify sensor responds to pH buffers. Replace sensor and/or sensor extension cable (if present) if sensor does not respond.5) Electronically test sensor. Replace sensor if sensor does not meet requirements.
PC5	OPEN	<ol style="list-style-type: none">1) See PC4 corrective actions.

Problem Code	Problem Text String	Corrective Action
PC6	HI.AO1	1) Verify process conditions are within configured output range. If process variable is outside configured range, increase output range. 2) Verify sensor wiring is properly connected. 3) Remove any liquids, oils, scales or corrosion from TB84PH terminal block or extension cable junction box terminals. Replace extension cable if corrosion is present. 4) Clean sensor and perform a buffer and process calibration. 5) Conduct a temperature calibration. If a temperature sensor is not being used, verify the analyzer is configured for TMP.SNS "NONE". 6) Electronically test the sensor and temperature compensator. Replace sensor if sensor does not meet requirements.
PC7	LO.AO2	1) See PC6 corrective actions.
PC8	HI.PV	1) Verify process conditions are within analyzer range. Process variable must be within analyzer range. 2) Also See PC4 corrective actions.
PC9	LO.PV	1) See PC8 corrective actions.
PC10	HI.TEMP	1) Verify process conditions are within analyzer range. Process variable must be within analyzer range. 2) Also see PC6 corrective actions.
PC11	LO.TEMP	1) See PC10 corrective actions.
PC12	HI.T.AD	1) See PC10 corrective actions. If all items check out, implement item 2. 2) Replace pH/ORP/pION Input PCB Assembly.
PC13	LO.T.AD	1) See PC12 corrective actions.
PC14	+HI.OFF	1) Clean Sensor and repeat buffer and/or process calibration. 2) Inspect sensor and cabling for shorts. Remove all potential shorts to ground, conduit or metal surfaces. 3) If sensor is functioning properly, order a spare sensor to replace the existing sensor. Replace existing sensor with spare when analyzer does not accept calibration values.
PC15	-HI.OFF	1) See PC14 corrective actions.
PC16	HI.EFF	1) Verify the proper buffer values were used for calibration and repeat buffer calibration. 2) Clean sensor and repeat buffer calibration.

Problem Code	Problem Text String	Corrective Action
PC17	LO.EFF	1) Verify the proper buffer values were used for calibration and repeat buffer calibration. 2) Clean sensor and repeat buffer calibration. 3) Look for shorts in the sensor and extension cable, if present. Remove all potential shorts. 4) Remove any liquids, oils, scales or corrosion from TB84PH terminal block or extension cable junction box terminals. Replace extension cable if corrosion is present. 5) If sensor is functioning properly, order a new sensor to replace existing sensor once the analyzer does not accept calibration values.
PC18	HI.AO2	1) See PC6 corrective actions.
PC19	LO.AO2	2) See PC6 corrective actions.
PC20	BAD.SEE	1) Input PCB Factory calibration constants can not be loaded. Calibrate sensor and order replacement pH/ORP/pION Input PCB Assembly. Existing PCB should properly function until new assembly is received.
PC21	NO.F.CAL	1) Contact Factory for calibration procedure. Calibrate sensor for short-term usage until factory calibration can be performed.
PC22	BLNK.uP	1) Cycle analyzer power. 2) Contact Factory.
PC23	SEE.EMI	1) See PC22 corrective action.
PC24	ROM.EMI	1) See PC22 corrective action.
PC25	ROM.SUM	1) See PC22 corrective action.
PC30	PV.F.CAL	1) Contact Factory for calibration procedure. Calibrate sensor for short-term usage until factory calibration can be performed.
PC31	BA.F.CAL	1) Contact Factory for calibration procedure. Calibrate temperature sensor for short-term usage until factory calibration can be performed.
PC32	PT.F.CAL	1) See PC31 corrective action.
PC33	RZ.F.CAL	1) Contact Factory for calibration procedure. Reference impedance diagnostic will not be operational until factory calibration is performed. Disable Diagnostics until factory calibration can be performed.
PC34	PV.CHKS	1) Cycle analyzer power. 2) Remove analyzer from installed location and relocate to a noise-free environment. If problem does not appear, the analyzer will need a different final location or additional shielding of the analyzer and/or wiring is necessary for proper function. 3) Contact Factory.

Problem Code	Problem Text String	Corrective Action
PC35	BA.CHKS	1) See PC34 corrective actions.
PC36	PT.CHKS	1) See PC34 corrective actions.
PC37	PZ.CHKS	1) See PC34 corrective actions.
PC40	HI.R.CKT	1) See PC2 corrective actions. If the sensor and connections are not the cause, proceed to item 2. 2) Input PCB reference impedance circuit failure exists. Disable diagnostics and order replacement pH/ORP/pION Input PCB Assembly. Existing PCB should properly function until new assembly is received.
PC41	LO.R.CKT	1) Verify sensor wiring is properly connected. 2) Electronically test the sensor. Replace sensor if sensor does not meet requirements. 3) Input PCB reference impedance circuit failure exists. Disable diagnostics and order replacement pH/ORP/pION Input PCB Assembly. Existing PCB should properly function until new assembly is received.
PC42	HI.RZ.AD	1) Input PCB reference impedance circuit failure exists. Disable Diagnostics and order replacement pH/ORP/pION Input PCB Assembly. Existing PCB should properly function until new assembly is received.
PC43	LO.RZ.AD	1) See PC42 corrective actions.
PC44	HI.G.CKT	1) See PC4 corrective actions. If the sensor and connections are not the cause, proceed to item 2. 2) Input PCB glass pH impedance circuit failure exists. Disable diagnostics and order replacement pH/ORP/pION Input PCB Assembly. Existing PCB should properly function until new assembly is received.
PC45	LO.G.CKT	1) See PC1 corrective actions. If the sensor and connections are not the cause, proceed to item 2. 2) Input PCB glass pH impedance circuit failure exists. Disable Diagnostics and order replacement pH/ORP/pION Input PCB Assembly. Existing PCB should properly function until new assembly is received.

Problem Code	Problem Text String	Corrective Action
PC46	HI.GL.AD	1) Input PCB glass pH impedance circuit failure exists. Disable diagnostics and order replacement pH/ORP/pION Input PCB Assembly. Existing PCB should properly function until new assembly is received.
PC47	LO.GL.AD	1) See PC46 corrective actions.
PC48	HI.C.CKT	1) Verify sensor wiring is properly connected. 2) Remove any liquids, oils, scales or corrosion from TB84PH terminal block or extension cable junction box terminals. Replace extension cable if corrosion is present. 3) Electronically test the sensor. Replace sensor if sensor does not meet requirements. 4) Input PCB cable diagnostic circuit failure exists. Disable Diagnostics and order replacement pH/ORP/pION Input PCB Assembly. Existing PCB should properly function until new assembly is received.
PC49	LO.C.CKT	1) See PC48 corrective actions.
PC50	HI.CA.AD	1) Input PCB cable diagnostic circuit failure exists. Disable Diagnostics and order replacement pH/ORP/pION Input PCB Assembly. Existing PCB should properly function until new assembly is received.
PC51	LO.CA.AD	1) See PC50 corrective actions.

WARNING

All error conditions are considered catastrophic. When such an error has been reported, the analyzer should be replaced with a known-good analyzer. The non-functional analyzer should be returned to the factory for repair. Contact the factory for a Return Materials Authorization (RMA) number.

SENSOR TROUBLESHOOTING

If the sensor is suspected of being the source of problems, a quick visual inspection in many cases will identify the problem. If nothing can be seen, a few electrical tests using a digital multimeter can be performed to determine if the sensor is at fault. Some of these tests can be performed with the sensor either in or out of the process stream.

Visual Sensor Inspection

Remove the sensor from the process and

visually check the following:

Sensor body

Inspect the sensor body for cracks and distortions. If any are found, contact ABB for alternative sensor styles and materials.

Cable and connectors

Inspect the sensor cable for cracks, cuts, or shorts. If a junction box and/or extension cable are used, check for moisture, oil, corrosion, and/or particulates. All connections must be dry, oil-free, corrosion-free, and particulate-free. Even slight amounts of moisture, skin oils, corrosion, and particulates can short sensor signals due to the high impedance of these signals. If a BNC connector is used, check to see that it is dry and not shorting against any metal, earth grounds, or conduit.

Measuring electrode

Inspect the glass electrode for breaks or cracks. If breakage is a problem, contact ABB for alternative electrode choices or suggestions regarding alternate sensor mounting locations.

Inspect the measurement electrode for foulants or scales. Many scales are not noticeable when the sensor is wet. Using a tissue, dry the glass electrode and hold it up to a bright light. Scaling will appear as a whitish, textured material on the surface of the electrode. Films will usually have a streaky, multi-colored appearance. Clean the electrode if it is fouled or scaled. See Section 15, Maintenance, for sensor cleaning procedures.

Reference junction

Inspect the reference junction (the area between the sensor body and measuring electrode) for heavy foulants or scaling. If foulants or hardness scales are present, remove foreign material using the procedures described in Section 15, Maintenance.

When mechanically cleaning the sensor, always use a soft bristle brush in order to avoid damaging the insulating coating on the solution ground (i.e., the metallic collar around the measuring electrode if present). This coating is only present on the outer diameter next to the reference junction and must be intact for the reference diagnostics to function properly.

If the junction (especially a wood junction) has been attacked by the process chemicals, contact ABB for alternate junction materials.

Solution ground and O-ring seals

On TBX Advantage sensors, inspect the solution ground (i.e., the metallic collar around the measuring electrode if present) and sealing O-rings for attack by the process liquid. If the solution ground shows evidence of corrosion or deterioration and/or the O-rings appear distorted or swollen, contact ABB for alternate material choices.

Sensor Electronic Test

The pH/ORP/pION sensor can be electronically tested to verify the integrity of the sensor elements and cable. These tests require a Digital Multimeter (DMM) that has a conductance function capable of measuring from 0 to 200 nS.

The sensor leads and automatic temperature compensator leads must be disconnected from the analyzer before these tests can be performed. Also the sensor must be placed in a container of water or buffer solution. If the sensor is a standard ABB sensor (i.e., TB5) which does not have a solution ground and has a BNC, the center conductor will be equivalent to the blue lead (i.e., Sense) and the shell will be equivalent to the black lead (i.e., Reference). Check the sensor using the following procedure.

1. Check the resistance of the Temperature Compensator. For a 3 kohm Balco RTD, the expected resistance can be calculated from:

$$R_{TC} = (3000) [1 + 0.0045(T - 25)]$$

where T is in degrees Celsius. The measured resistance should be within the expected value by $\pm 15\%$. At room temperature (i.e., 25°C), the resistance value should be approximately 3 kohms.

For a Pt100 RTD, the expected resistance can be calculated from:

$$R_{TC} = 100 [1 + 0.00385(T - 0)]$$

where T is in degrees Celsius. The measured resistance should be within the expected value by $\pm 5\%$. At room temperature (i.e., 25°C), the resistance value should be approximately 110 ohms.

2. Check the conductance between the red Temperature Compensator lead and each of the other sensor leads (i.e., blue, yellow, black, green, and heavy green leads). The reading must be less than 0.05 nS.

3. Check the conductance between the yellow Guard lead and each of the other sensor leads (i.e., blue, black, green, red, white, and heavy green leads). The reading must be less than 0.05 nS.

4. Check the conductance between the heavy green lead (i.e., Shield) and each of the other sensor leads (i.e., blue, yellow, black, green, red, and white leads). The reading must be less than 0.05 nS.

5. Check the conductance of the sensor measurement electrode by measuring across the blue and green leads. The conductance must be 1 to 10 nS when the sensor and solution in contact with the sensor is at 25°C. (If the sensor and solution are above or below 25°C, the conductance value can be estimated as one-half the conductance for every eight degrees above 25°C or double the conductance for every eight degrees below 25°C.)

6. Check the voltage of the sensor reference electrode by measuring across the black lead for the sensor under test and the black lead of a known good sensor. For this test, the sensor under test must be removed from the process and placed into a buffer solution. The known good sensor must also be placed in the same buffer solution. The voltage must be between -180 mV and +180 mV.

SECTION 15 - MAINTENANCE

INTRODUCTION

The reliability of any stand-alone product or control system is affected by maintenance of the equipment. ABB recommends that all equipment users practice a preventive maintenance program that will keep the equipment operating at an optimum level.

Personnel performing preventive maintenance should be familiar with the TB84PH Advantage Series analyzer.

WARNING

<p>Allow only qualified personnel (refer to INTENDED USER in SECTION 1 - INTRODUCTION) to commission, operate, service or repair this equipment. Failure to follow the procedures described in this instruction or the instructions provided with related equipment can result in an unsafe condition that can injure personnel and damage equipment.</p>

PREVENTIVE MAINTENANCE

Table 15-1 is the preventive maintenance schedule and check list for the TB84PH Advantage Series analyzer. The table lists the preventive maintenance tasks in groups according to their specified maintenance interval. The maintenance intervals are recommendations and may vary depending on the location environment and the process application. As a minimum, these recommended maintenance tasks should be performed during an extended process shutdown. Tasks in Table 15-1 are self-explanatory. For sensor cleaning procedures, refer to CLEANING THE SENSOR.

Table 15-1. Preventive Maintenance Schedule

Preventive Maintenance Tasks	Interval (months)
Check and clean all wiring and wiring connections	12
Clean and inspect sensor	As required.
Clean and lubricate all gaskets and O-rings	Each time seals are broken.
Analyzer output calibration	12
Sensor calibration	As required.

Cleaning the Sensor

ABB pH/ORP/pION sensors are cleaned using one or a combination of the following methods. These are recommendations and may not be suitable for all applications. Other cleaning methods may be developed that better suit particular applications. When cleaning, observe all safety precautions required for handling chemicals. When handling chemicals, always use gloves, eye protection, safety shield, and similar protective items, and consult **Material Safety Data Sheets**.

WARNING

Consider the material compatibility between cleaning fluids and process liquids. Incompatible fluids can react with each other causing injury to personnel and equipment damage.

WARNING

Use solvents only in well ventilated areas. Avoid prolonged or repeated breathing of vapors or contact with skin. Solvents can cause nausea, dizziness, and skin irritation. In some cases, overexposure to solvents has caused nerve and brain damage. Solvents are flammable - do not use near extreme heat or open flame.

Acid Dip

Dip the tip of the sensor into a one to five percent hydrochloric acid (HCl) solution until this region is free of the unwanted coating. Minimize expose of any metal on the sensor, if present, to this cleaning solution. Corrosion may occur. This method removes scales from water hardness. After dipping, rinse sensor with water.

Solvent Dip Dip the sensor into a solvent such as isopropyl alcohol. Remove solvent using a clean cloth. Do not use solvents which are known to be incompatible with the plastic of the sensor. This method removes organic coatings. After dipping, rinse sensor with water.

Physical Cleaning Use a rag, acid brush, or tooth brush to remove especially thick scales and accumulations. Take caution in cleaning the glass pH electrode, if present, to prevent glass breakage.

When mechanically cleaning the sensor, always use a soft bristle brush in order to avoid damaging the insulating coating on the solution ground (i.e., the metallic collar around the measuring electrode if present). This coating is only present on the outer diameter next to the reference junction and must be intact for the reference diagnostics to function properly.

SECTION 16 - REPLACEMENT PROCEDURES

INTRODUCTION

Due to the modular design of the TB84PH Advantage Series analyzer, the replacement of an assembly can be easily completed. Replacements are available for each major assembly. These include the pH/ORP/pION input PCB, microprocessor PCB, power supply PCB, front bezel, shell, and rear cover assemblies. This section provides removal and installation procedures for these assemblies. Use Figure 16-1 as a reference during removal and installation procedures.

NOTE: Refer to Section 3 for special handling procedures when removal of electronic assemblies is required.

WARNING	Substitution of any components other than those assemblies listed in this section will compromise the certification listed on the analyzer nameplate. Invalidating the certifications can lead to unsafe conditions that can injure personnel and damage equipment.
WARNING	Do not disconnect equipment unless power has been switched off at the source or the area is known to be nonhazardous. Disconnecting equipment in a hazardous location with source power on can produce an ignition-capable arc that can injure personnel and damage equipment.

ELECTRONIC ASSEMBLY REMOVAL/REPLACEMENT

1. Turn off power to the analyzer. Allow at least 1 minute for the analyzer to discharge.
2. Remove the Front Bezel Assembly by unscrewing the four captive screws and lightly pulling the bezel from the shell.

3. Remove the four 6-32 machine screws that retain the Power Supply and pH/ORP/pION Input PCB assemblies if both assemblies or the Microprocessor PCB Assembly are being replaced.

4. Release the keypad ribbon cable connector latch located on the outside edges of the connector and remove the ribbon cable from the connector.

5. Remove the two 6-32 machine screws that retain the Microprocessor PCB Assembly.

6. Replace the appropriate PCB assembly and follow the reverse of this procedure to re-assemble the analyzer.

FRONT BEZEL ASSEMBLY REMOVAL/REPLACEMENT

1. Turn off power to the analyzer. Allow at least 1 minute for the analyzer to discharge.

2. Remove the Power Supply, pH/ORP/pION Input, Microprocessor PCB Assemblies as described in Electronic Assembly Removal/Replacement procedure.

3. Attach the Power Supply, pH/ORP/pION Input, and Microprocessor PCB Assemblies to the new Front Bezel Assembly, and install it into the Shell Assembly as described in Electronic Assembly Removal/Replacement procedure.

SHELL ASSEMBLY REMOVAL/REPLACEMENT

1. Turn off power to the analyzer. Allow at least 1 minute for the analyzer to discharge.

2. Remove the Front Bezel Assembly by unscrewing the four captive screws and lightly pulling the bezel from the shell.

3. Remove the Rear Cover Assembly by unscrewing the four captive screws.

4. Replace the old Shell Assembly with the new one.

5. Install the Rear Cover and Front Bezel Assemblies and tighten the eight captive screws.

REAR COVER ASSEMBLY REMOVAL/REPLACEMENT

1. Turn off power to the analyzer. Allow at least 1 minute for the analyzer to discharge.
2. Remove the Rear Cover Assembly by unscrewing the four captive screws.
3. Replace with the new Rear Cover Assembly.
4. Tighten the four captive screws.

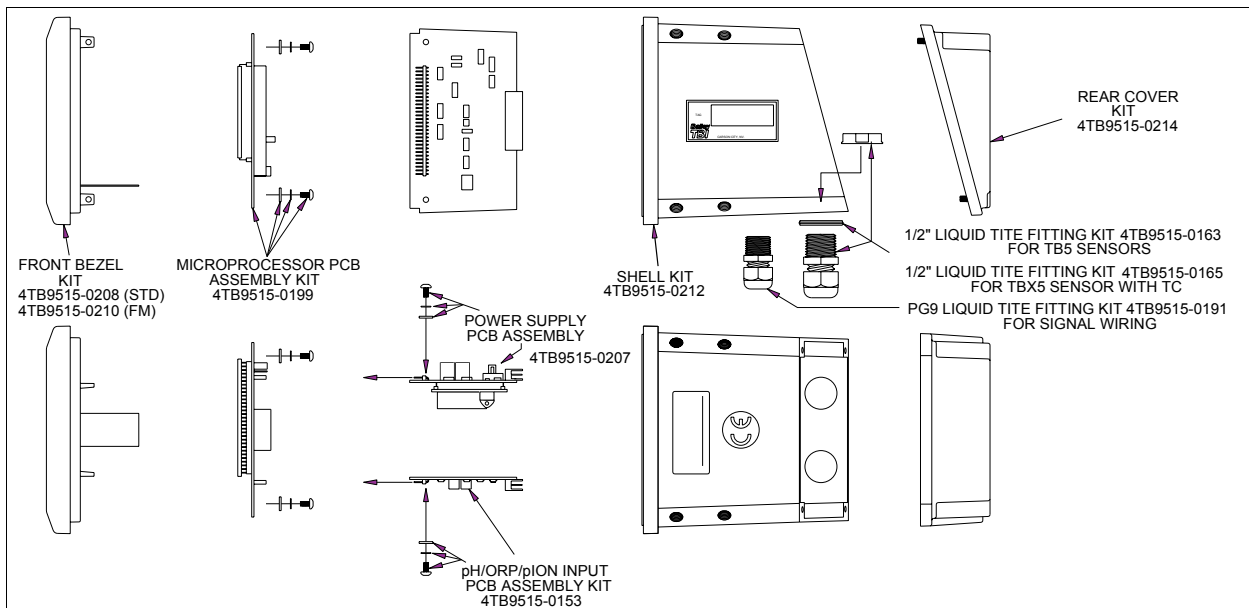

Figure 16-1. TB84PH Advantage Series Exploded View Showing Kit Assignments.

SECTION 17 - SUPPORT SERVICES

INTRODUCTION

ABB Controls is ready to help in the use and repair of its products. Requests for sales and/or application services should be made to the nearest sales or service office.

Factory support in the use and repair of the TB84PH Advantage Series analyzer can be obtained by contacting:

ABB Inc.
9716 S. Virginia ST., Ste.E
Reno, Nevada 89511 USA
Phone: 1(775)850-4800
Facsimile: 1(775)850-4808
Web Site: www.abb.com/instrumentation

RETURN MATERIALS PROCEDURES

If any equipment should need to be returned for repair or evaluation, please contact ABB Inc. at (775)883-4366, or your local ABB representative for a Return Materials Authorization (RMA) number. At the time the RMA number is given, repair costs will be provided, and a customer purchase order will be requested. The RMA and purchase order numbers must be clearly marked on all paperwork and on the outside of the return package container (i.e., packing box).

Equipment returned to ABB Inc. with incorrect or incomplete information may result in significant delays or non-acceptance of the shipment.

REPLACEMENT PARTS

When making repairs at your facility, order spare parts kits from a ABB sales office. Provide the following information.

1. Spare parts kit description, part number, and quantity.
2. Model and serial number (if applicable).
3. ABB instruction manual number, page number, and reference figure that identifies the spare parts kit.

When you order standard parts from ABB, use the part numbers and descriptions from **RECOMMENDED SPARE PARTS KITS** sections. Order

parts without commercial descriptions from the nearest ABB sales office.

RECOMMENDED SPARE PARTS KITS

Table 17-1. Spare Parts Kits

Part Number	Description
4TB9515-0124	Pipe Mount Kit
4TB9515-0125	Hinge Mount Kit
4TB9515-0123	Panel Mount Kit
4TB9515-0156	Wall Mount Kit
4TB9515-0208	Front Bezel Kit - Standard
4TB9515-0210	Front Bezel Kit - FM Version
4TB9515-0212	Shell Kit
4TB9515-0214	Rear Cover Kit
4TB9515-0163	½" Liquid-Tite Cable Grip Fitting Kit - Compatible with TBX5 Sensors
4TB9515-0165	½" Liquid-Tite Cable Grip Fitting Kit - Compatible with TB5 Sensors
4TB9515-0191	PG9 Liquid-Tite Cable Grip Fitting Kit - Compatible with most signal cabling sizes
4TB9515-0198	Complete Cable Grip Kit - Two ½" Liquid-Tite Cable Grips (p/n 4TB9515-0165) and three PG9 Liquid-Tite Cable Grips (p/n 4TB9515-0165)
4TB9515-0207	Power Supply PCB Assembly Kit
4TB9515-0199	Microprocessor PCB Assembly Kit
4TB9515-0153	pH/ORP/pION Input PCB Assembly Kit
4TB9515-0164	BNC/TC to TB84PH Pin Adapter
4TB9515-0166	BNC to TB84PH Pin Adapter w/ ½" Liquid-Tite Fitting For Sensors w/ BNC (i.e., TB5 Sensors)

APPENDIX A - TEMPERATURE COMPENSATION

GENERAL

The TB84PH Advantage Series analyzer has three types of temperature compensation options. These include Manual Nernstian, Automatic Nernstian, and Automatic Nernstian with Solution Coefficient.

The effect of temperature on ORP and pION sensors is difficult to characterize, except for specific applications. For these reasons, only the Solution Coefficient option can be used to temperature compensate for electrode and/or process effects.

NERNSTIAN TEMPERATURE COMPENSATION

Manual and Automatic Nernstian Temperature Compensation adjusts for the thermodynamic properties of electrochemical half cells. The Nernstian effect is characterized by the mathematical equation:

$$E' E_{Reference} \% = \frac{2.3(R(T_K LOG[a_i])}{n(F)}$$

where:

- E = Overall Sensor Output.
- E_{Reference} = Reference Half Cell Output (typically a constant).
- R = Constant
- T_K = Absolute Temperature (Kelvin).
- n = Ion Charge.
- F = Constant.
- [a_i] = Ion Activity.

Since the ion activity (i.e., [a_i]) is nearly equal to the ion concentration for weak solutions, the Nernst Equation can be used to convert the sensor output into pH values for pH sensors and concentration values for pION sensors.

Temperature effects on pION and ORP sensors are not easily characterized; therefore, the Nernstian relationship is not used on these types of sensors. Conversely, pH sensors are well behaved and can be characterized by this Nernst Equation.

The TB84PH Advantage Series analyzer applies Nernstian compensation to all three pH temperature compensation options. If the user is interested in the uncompensated value, setting the TB84PH Advantage Series analyzer to Manual and calibrating the temperature to 25°C will allow them to monitor the uncompensated value. Automatic Nernstian (AUTO) provides the most useful information and is recommended in most cases.

Since ion dissociation is affected by temperature, the pH value can be also affected. If these processes behave in a repeatable manner, the dissociation can be characterized and a Solution Coefficient can be used to compensate for these effects.

SOLUTION COEFFICIENT

The solution coefficient compensates the Nernstian value, in the case of pH, and the raw voltage value, in the case of ORP or pION. The coefficient is applied as a fixed value per each 10°C away from 25°C. The temperature compensation factor is derived from the following equations:

$$pH_{Indication} = pH_{Nernstian} \pm COEF \left(\frac{(T-25)EC}{10EC} \right)$$

$$mV_{Indication} = mV \pm COEF \left(\frac{(T-25)EC}{10EC} \right)$$

where:

COEF = pH or mV change per 10 degrees Celsius.

$pH_{Nernstian}$ = Nernstian pH Value referenced at 25°C after applying the factory and process calibration values.

$pH_{Indication}$ = pH Value indicated on the analyzer.

mV = mV Value of the sensor output after applying the factory and process calibration values.

$mV_{Indication}$ = mV Value indicated on the

analyzer.
T = Temperature of the solution in °C
after applying the factory and
process calibration values.

For example, solution coefficients for pure
water applications are:

Pure Water = +0.18 pH/10°C
Pure Water w/ 1ppm Ammonia = +0.31 pH/10°C

For the TB84PH Advantage Series analyzer, the
solution coefficient will either add (+) or
subtract (-) a configured amount of the
process variable per 10°C to the Nernstian
compensated process variable. Thus, an
application having a process liquid that
decreases in its pH value as the temperature
increases should use a positive (+) solution
coefficient correction factor. Conversely, an
application having a process liquid that
increases in its pH value as the temperature
increases should use a negative (-) solution
coefficient correction factor. For ORP and
pION analyzer types, the solution coefficient
adjusts the uncompensated process variable and
does not use the Nernstian relationship.

APPENDIX B - PROGRAMMING TEXT STRING GLOSSARY

GENERAL

When programming the TB84PH Advantage Series analyzer, the six digit, alphanumeric region will display a wide variety of text prompts. In many cases, these prompts are abbreviations or portions of words. This section contains a complete list of the text prompts and their full text equivalent.

GLOSSARY OF PROGRAMMING TEXT PROMPTS

Table B-1. Glossary of Text Prompts

TEXT STRING	DESCRIPTION
1PT.CAL	One Point Calibration
20MA.PT	20 Milliamp Point
2PT.CAL	Two Point Calibration
3K.BLCO	3 kohm Balco (Temperature Compensation)
4MA.PT	4 Milliamp Point
REV.A10	Software Revision A10
ADVNC	Advanced (Programming Mode)
ANALZR	Analyzer State
ANTMNY	Antimony (pH Sensor with Antimony Measurement Electrode)
ASY.POT	Asymmetric Potential
AUT.SOL	Automatic Temperature Compensation (Nernstian) with Solution Coefficient
AUTO	Automatic Temperature Compensation (Nernstian)
BAD.CAL	Bad Calibration - Entered values caused the calculated values to exceed maximum values.
BAD.VAL	Bad Value - Entered value exceeded maximum allowable value for the entered parameter.
CALIBR	Calibrate Mode
CONFIG	Configure Mode
DAMPNG	Damping State
DIAGS	Diagnostics State

TEXT STRING	DESCRIPTION
DISABL	Disable
END.MV	Ending Millivolt Point (For Specific Ion Concentration configuration only).
END.MAG	Ending Magnitude Point (For Specific Ion Concentration configuration only).
FAIL.HI	Fail High (i.e., 20 mA)
FAIL.LO	Fail Low (i.e., 4 mA)
HI.VAL	High Calibration (Buffer or Standard) Value
ION.CAL	Specific Ion Calibration
ION.CON	Specific Ion Concentration
ISO.PT	Isopotential Point
---KRZ	Reference Impedance in kohms where --- is the impedance value.
LO.VAL	Low Calibration (Buffer or Standard) Value
MAGS	Magnitudes - Number of decades the output range will cover (For Specific Ion Concentration configuration only).
MV/10C	Millivolt per 10°C (Solution Coefficient value for Automatic Nernstian with Solution Coefficient Temperature Compensation)
NEW.VAL	New Calibration Value - The PV or Temperature value expected during a One Point or Temperature Calibration.
NON.LIN	Non-Linear Output State
ORP.CAL	ORP Calibration State
OUT.CAL	Output Calibration State
PASSWD	Security Password
PH.CAL	pH Calibration State
PH.GLAS	pH Glass (pH Sensor with Glass Measurement Electrode)
PT 100	Pt100 Ohm RTD
REF Z	Reference Impedance
REL.HLD	Release Hold

TEXT STRING	DESCRIPTION
RERANG	Rerange State
RST.ALL	Reset All Parameters to Factory Settings
RST.CAL	Reset Calibration Constant and Data to Factory Settings
RST.CON	Reset Configurations to Factory Defaults
RST.SEC	Reset Security - Remove any existing security.
SAFE.MD	Safe Mode State
SEC.DSP	Secondary Display Mode
SECS	Seconds
SECUR	Security Mode
SPK.MAG	Spike Output Magnitude
SPK.OFF	Spike Output Function set to Off (i.e., Disable)
STABL?	Is the displayed Process Variable Stable?
TC.TYPE	Temperature Compensation Type State
TMP.CAL	Temperature Calibration State
TMP.SNS	Temperature Sensor Type State
TMP°C	Temperature in degrees Celsius
VALENC	Ion Valence State (For Specific Ion Concentration configuration only).
X-1	Nonlinear X Input Point value for Breakpoint 1 in percentage of input.
Y-1	Nonlinear Y Output Point value for Breakpoint 1 in percentage of output.

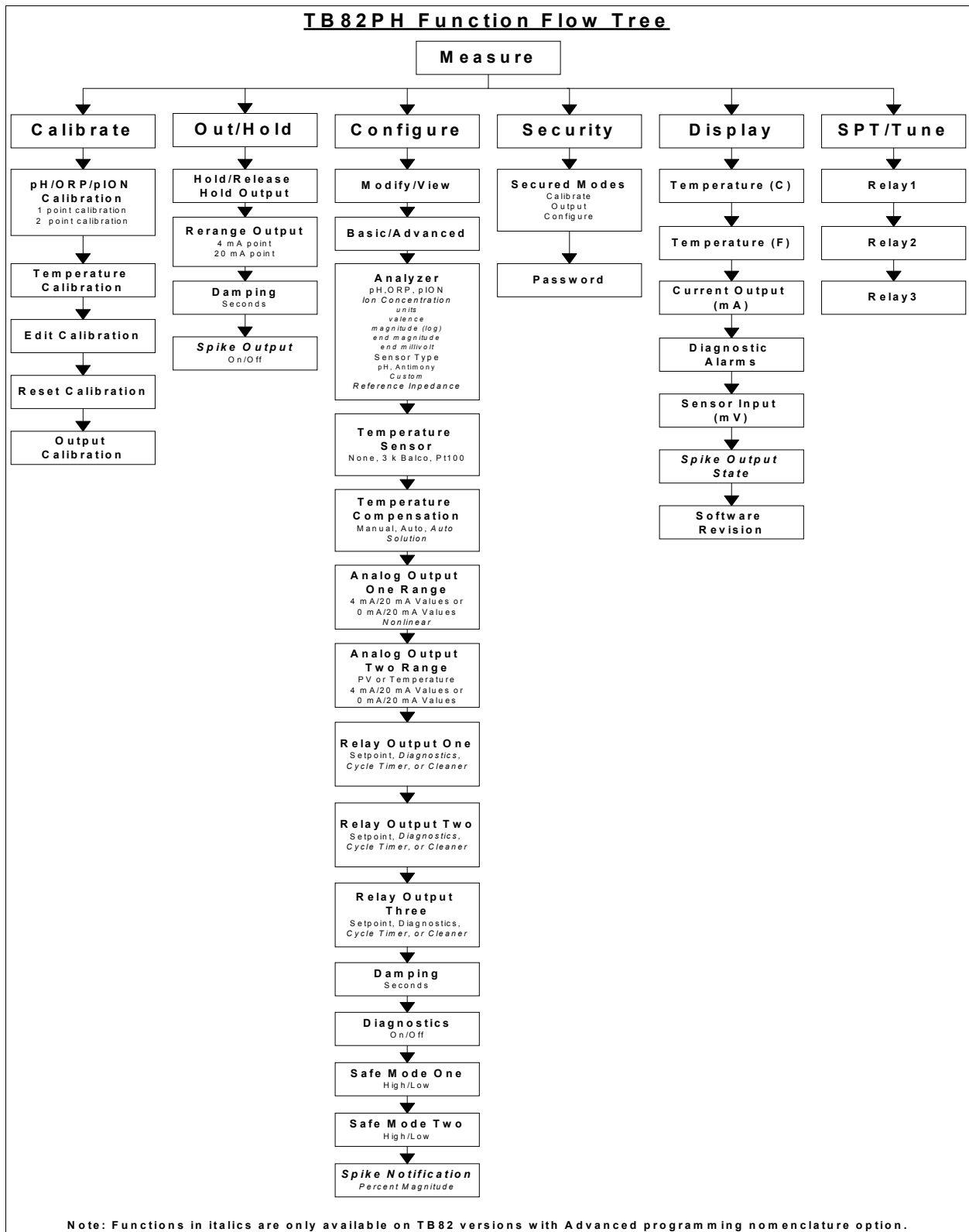

Figure B-1. TB84PH Programming Function Flow Chart.

APPENDIX C - CONFIGURATION WORKSHEETS



Form E67-84-1B Litho in U.S.A. June 2004
Copyright © 2004 by ABB., as an Unpublished Work, All Rights Reserved
® Registered Trademark of ABB.
™ Trademark of ABB.

ABB Inc.
9716 S. Virginia St., Ste. E
Reno, Nevada 89511
USA
Tel: +1 775-850-4800
Fax: +1 775-850-4808

ABB Ltd
Oldends Lane, Stonehouse
Gloucestershire, GL 10 3TA
UK
Tel: +44 (0) 1453-826661
Fax: +44 (0) 1453-829671

**ABB Automation Products
GmbH**
Heerdter Landstr. 193
D-40549 Düsseldorf
Tel: +49 (211) 50077300
Fax: +49 (211) 50077333

The Company's policy is one of continuous product improvement and the right is reserved to modify the information contained herein without notice.