

# Operating Instructions FOUNDATION fieldbus

# Conductivity Transmitters Model TB82EC 4-Electrode

IndustrialIT  
enabled™



---

**ABB**

---

# ABB Incorporated

---

---

## The Company

---

ABB Incorporated is an established world force in the design and manufacture of instrumentation for industrial process control, flow measurement, gas and liquid analysis and environmental applications.

As a part of ABB, a leader in process automation technology, we offer customers application expertise, service and support worldwide.

We are committed to teamwork, high quality manufacturing, advanced technology and unrivalled service and support.

The quality, accuracy and performance of the Company's products result from over 100 years experience, combined with a continuous program of innovative design and development to incorporate the latest technology.

QMI ISO 9001



Carson City, NV USA Facility- Cert. No. 001010

## Use of Instructions



### Warning.

An instruction that draws attention to the risk of injury or death.



### Note.

Clarification of an instruction or additional information.



### Caution.

An instruction that draws attention to the risk of damage to the product, process or surroundings.



### Information.

Further reference for more detailed information or technical details.

Although **Warning** hazards are related to personal injury, and **Caution** hazards are associated with equipment or property damage, it must be understood that operation of damaged equipment could, under certain operational conditions, result in degraded process system performance leading to personal injury or death. Therefore, comply fully with all **Warning** and **Caution** notices.

Information in this manual is intended only to assist our customers in the efficient operation of our equipment. Use of this manual for any other purpose is specifically prohibited and its contents are not to be reproduced in full or part without prior approval of Technical Communications Department, ABB Automation.

## Health and Safety

To ensure that our products are safe and without risk to health, the following points must be noted:

1. The relevant sections of these instructions must be read carefully before proceeding.
2. Warning labels on containers and packages must be observed.
3. Installation, operation, maintenance and servicing must only be carried out by suitably trained personnel and in accordance with the information given.
4. Normal safety precautions must be taken to avoid the possibility of an accident occurring when operating in conditions of high pressure and/or temperature.
5. Chemicals must be stored away from heat, protected from temperature extremes and powders kept dry. Normal safe handling procedures must be used.
6. When disposing of chemicals ensure that no two chemicals are mixed.

Safety advice concerning the use of the equipment described in this manual or any relevant hazard data sheets (where applicable) may be obtained from the Company address on the back cover, together with servicing and spares information.

---

## CONTENTS

---

Section	Page
CONTENTS .....	3
INTRODUCTION.....	3
SUPPLEMENTARY DOCUMENTATION.....	3
TRANSPORT .....	4
STORAGE .....	4
HANDLING .....	4
PRODUCT IDENTIFICATION .....	4
PRINCIPLE OF OPERATION .....	5
INSTALLATION.....	7
ELECTRICAL CONNECTIONS.....	8
LOCAL HMI OPERATING PROCEDURES .....	9
MEASURE MODE.....	10
CALIBRATE MODE.....	11
Process Variable Calibrate State .....	11
Temperature Calibrate State .....	11
Edit Calibrate State .....	12
Reset Calibrate State .....	12
OUTPUT/HOLD MODE.....	13
CONFIGURE MODE .....	13
Analyzer State.....	14
Temperature Sensor State .....	16
Temperature Compensation State .....	16
Diagnostic State.....	18
SECURITY MODE.....	19
SECONDARY DISPLAY MODE.....	19
UTILITY MODE .....	20
Reset Configuration State .....	20
Reset Security State .....	20
Reset All State .....	20
Reset Software State .....	20
Transmitter Identification (FF.ID) State .....	21
Damping State .....	21
TRANSMITTER'S FIELDBUS FUNCTIONALITY.....	21
DEVICE BLOCKS .....	23
HARDWARE DIP SWITCH FUNCTIONS .....	40
SIMPLE FAULT FINDING.....	41
DIAGNOSTIC INFORMATION.....	42
Calibration Diagnostic Messages .....	43
Additional Diagnostic Messages .....	44
SENSOR TROUBLESHOOTING .....	44
Visual Sensor Inspection .....	44
Sensor Electronic Test .....	44
Transmitter Electronic Test.....	45
DIAGNOSTIC INFORMATION RECEIVED FROM THE FIELDBUS .....	47
DISMANTLING AND REASSEMBLY .....	50
SPECIFICATIONS .....	51
GLOSSARY OF PROGRAMMING TEXT PROMPTS .....	54
PRODUCTS & CUSTOMER SUPPORT .....	57
Analytical Instrumentation .....	57
Controllers & Recorders .....	57
Flow Metering.....	57
Level Control .....	57
Pneumatic Instrumentation .....	57

---

## INTRODUCTION

---

The **TB82EC Four-Electrode Conductivity FOUNDATION Fieldbus (FF) Transmitters** are a modular range of field mounted, microprocessor-based instruments. Accurate and reliable measurement of solution conductivity is provided, in the even most difficult and hazardous industrial environments.

The TB82 family of transmitters offers Analog (4-20 mA output), Analog with HART digital communication, Profibus PA, and FOUNDATION Fieldbus product versions.

This manual describes the features, installation requirements, configuration commissioning, and calibration procedures related to the TB82EC Four-Electrode Conductivity FF Transmitter.

The delivery of the TB82EC FF device includes the Device Description and Capability files.

Refer to the supplementary documentation section to obtain additional information on the FOUNDATION Fieldbus communication protocol and device installation.

---

## SUPPLEMENTARY DOCUMENTATION

---

Reference information on FOUNDATION Fieldbus design and structure can be found in the following documents:

- Document 30 Fb 10 Fieldbus Solutions from ABB - Technical brochure
- IEC 61158-2 Fieldbus standard for use in industrial control systems – Part 2: Physical Layer specification and service definition
- FD-140 31.25 kbit/s Wiring and Installation Guide
- FF-801 Network Management Specification
- FF-800 System Management Specification
- FF-821 Data Link Layer Services Subset Specification
- FF-822 Data Link Layer Protocol Subset Specification
- FF-875 Fieldbus Access Sub-layer Specification
- FF-870 Fieldbus Message Specification
- FF-890 Function Blocks
- FF-891 Function Blocks - Part 2 specification
- FF-892 Function Blocks - Part 3 specification

Visit the internet site for online/up-to-date information:  
[www.abb.com](http://www.abb.com) or [www.fieldbus.org](http://www.fieldbus.org)

## TRANSPORT

After factory calibration, the instrument is packed in a carton, intended to provide protection from physical damage.

## STORAGE

The instrument does not require any special treatment if stored as dispatched and within the specified ambient conditions level listed in the Specification section. There is no limit to the storage period.

## HANDLING

The instrument does not require any special precautions during handling, though care should be observed.

## PRODUCT IDENTIFICATION

The following data plates shown in Figure 1 identify the instrument.

The Nameplate (Reference A) provides information concerning the product identity code (i.e., nomenclature), product name, operating voltage range, output type, serial number, test personnel badge number, and dielectric strength verification stamp.

The Agency Approval label (Reference B) is included when the transmitter is purchased for compliance with hazardous area regulations (e.g., intrinsic safety protection) for a specific country (e.g., CSA, FM, or CENELEC).

EC conformance is identified using a CE label (Reference C). Optional tagging specified by customer requirements is provided via a supplementary tag (Reference D).

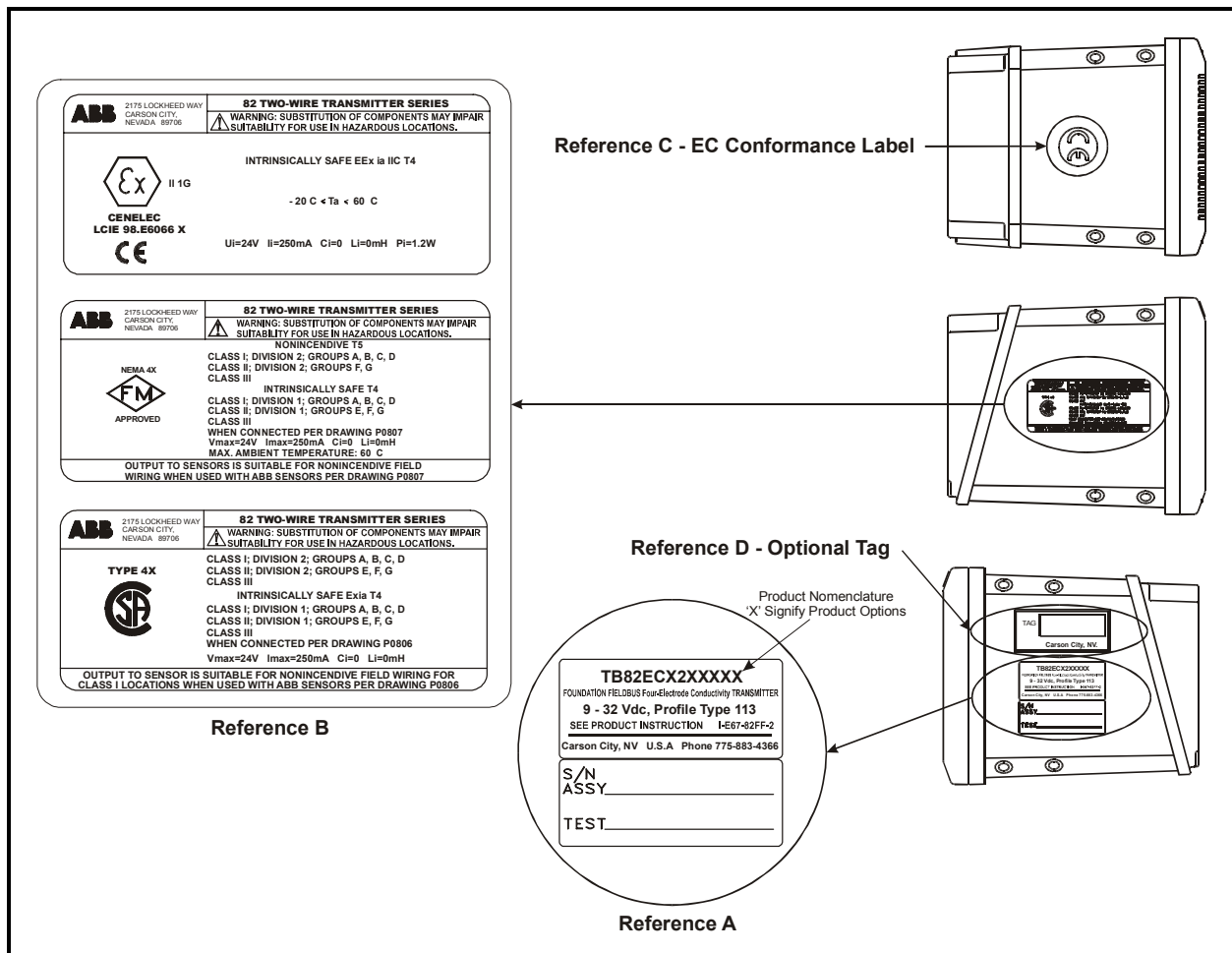

Figure 1 – Product Identification

## PRINCIPLE OF OPERATION

The TB82EC Four-Electrode Conductivity FOUNDATION Fieldbus Transmitter provides on-line measurement of liquid properties in industrial environments using an advanced microprocessor-based technology. Transmitter power and digital communication based on the FOUNDATION Fieldbus protocol is provided by fieldbus wiring. The TB82EC transmitter can be installed indoors or outside due to its IP65 and NEMA 4X environmental enclosure ratings. Cable glands for field wiring ensure adequate sealing barriers to ambient conditions while maintaining the environmental ratings of the transmitter.

The Human Machine Interface (HMI), shown in Figure 2, consists of a tactile keypad having four universal keys, one hidden key, and a custom LCD. The LCD has a three and one-half digit numeric region that displays the process variable, a six-digit alphanumeric region that displays secondary information and programming prompts, and several status-indicating and programming icons. Each of the four universal keys is located under a set of icons. In each of the instrument modes and states, one icon over a given key will be illuminated and will represent that key's function. These assignments vary and depend upon the programming mode or state the transmitter is currently occupying. In addition to the key assignments, text strings located in the six character alphanumeric field are used as programming prompts.

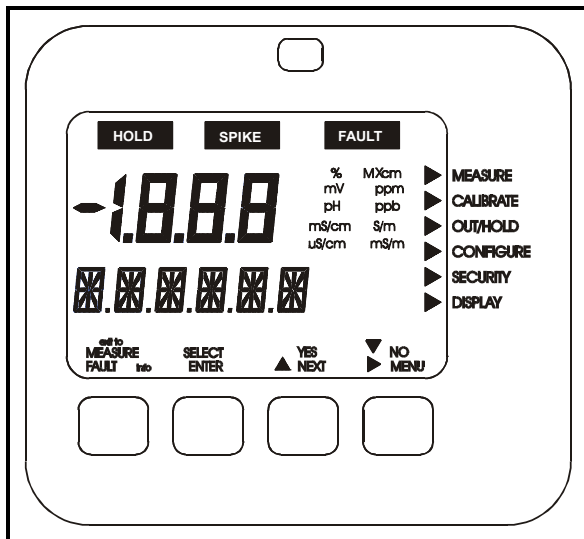

Figure 2 – TB82PH HMI

The signal conditioning circuitry contained in the transmitter is designed to process voltage and current measurements generated by ABB's four-electrode conductivity sensors. This circuit processes the sensor signal into a format that is transferred to a secondary circuit. The secondary circuit uses a

microprocessor to compute the precise primary variable compensating for the combined effects of circuit tolerances, sensor calibration information, and temperature effects. Permanent memory stores transmitter and sensor specific information such as:

- Non-modifiable data such as the serial number, the UID (Unique Identifier), the manufacturer's name and device type, the hardware and software version of the electronics.
- Modifiable data such as transmitter configuration information, sensor calibration data, and security passwords.

The sensor and all electronic parts are galvanically isolated from the transmitter body. This isolation is verified at the factory using a Dielectric Strength Test.

The instrument consists of three functional circuits that have been divided into three unique Printed Circuit Board (PCB) assemblies:

- Signal Conditioning Input Assembly
- Microprocessor/Display Assembly
- Power Supply/Communication Assembly

A block diagram representing the electronic functional areas is shown in Figure 3. The flow of information starts from the sensor input and moves through the transmitter to the FOUNDATION Fieldbus interface that produces a digital signal compliant with FOUNDATION Fieldbus specification (IEC-61158-2 - see Supplementary Documentation). The digital communication and HMI capabilities provide for remote or local access to transmitter parameters for configuration and maintenance operations.

The fieldbus furnishes transmitter power and can be configured as a point-to-point, tree, Daisy Chain, or Trunk/Spurs network. Modulating the base quiescent current generates the communication signals. The quiescent current value is used as a reference in order to establish the number of devices that can be installed on a single bus line.

Data is transmitted over the bus using the digital, bit-synchronous Manchester II coding at a baud rate of 31.25 kbit/sec. Figure 4 shows an example of a typical bus configuration using ABB's FIO100 interface module.

## ... PRINCIPLE OF OPERATION

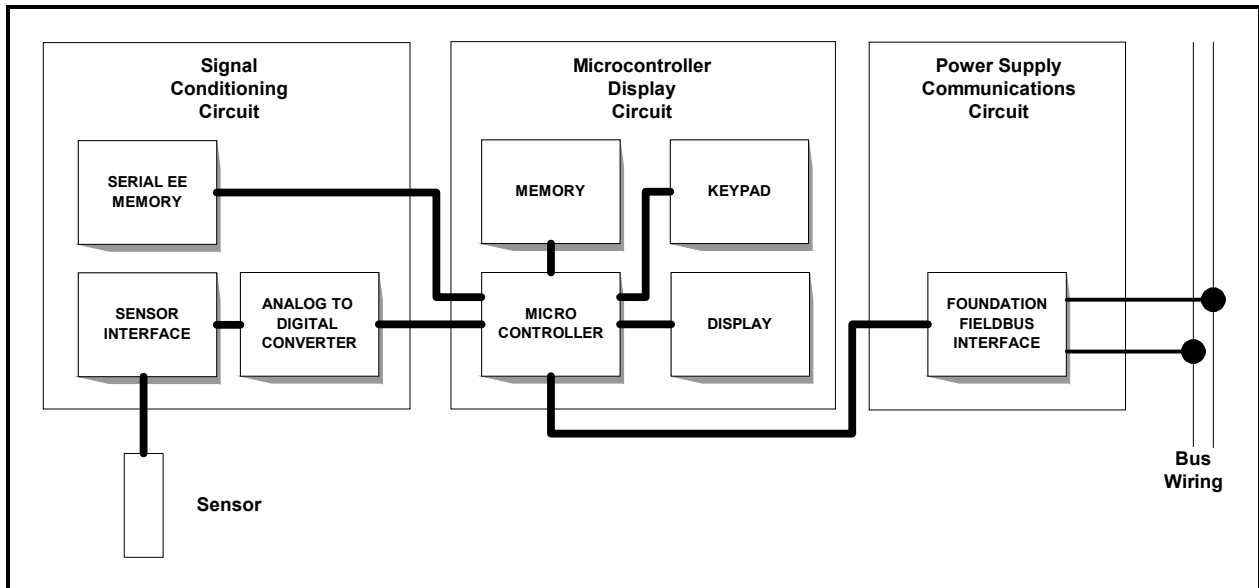

Figure 3 – Functional Block Diagram for FOUNDATION Fieldbus

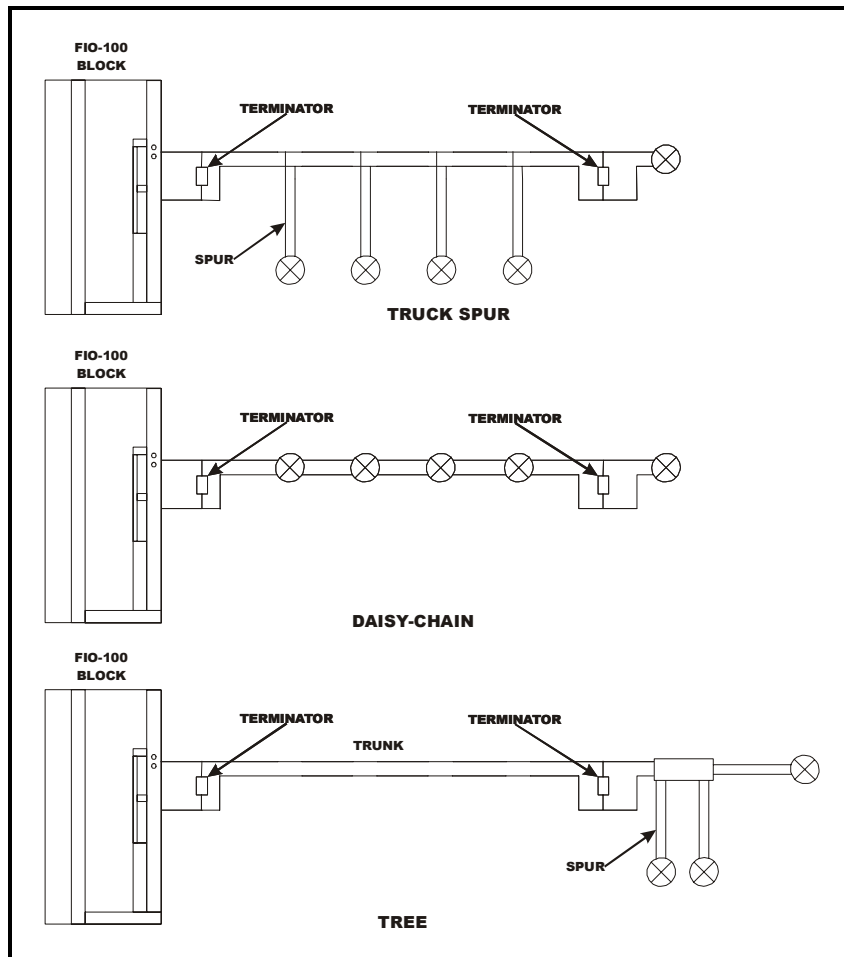

Figure 4 – Typical Bus Configurations

# INSTALLATION

Besides the normal precautions for storage and handling of electronic equipment, the transmitter contains static sensitive devices. Since semiconductors can be damaged by the direct discharge of static electricity, avoid contact with terminal block conductors and electronic components on the circuit board.

When mounting the transmitter, choose a location that has ample clearance for the removal of the front bezel and rear cover. The location should provide easy access for maintenance procedures and not be in a highly corrosive environment. Excessive mechanical vibrations and shocks as well as relay and power switches should not be in the immediate area. Signal wiring should not be placed in conduit or open trays that contain power wiring for heavy electrical equipment. Field wiring should meet wiring practices appropriate for fieldbus devices (See Supplementary Documentation).

The transmitter can be pipe, hinge, wall or panel mounted. Use the appropriate figure below to assist in the mechanical installation of the transmitter.

**Warning.**

For installation in Hazardous Areas, i.e. areas with danger of fire and/or explosion, irrespective of the protection mode used, the installation must be carried out in accordance with local authority regulations. Ensure also that the temperature of the transmitter does not exceed the value indicated in the Safety Marking plate.

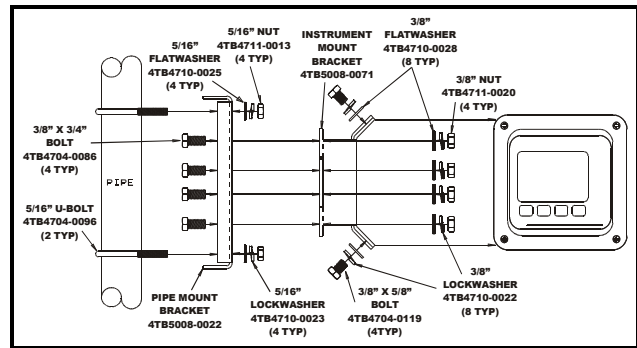

Figure 5 – Pipe Mounting Detail

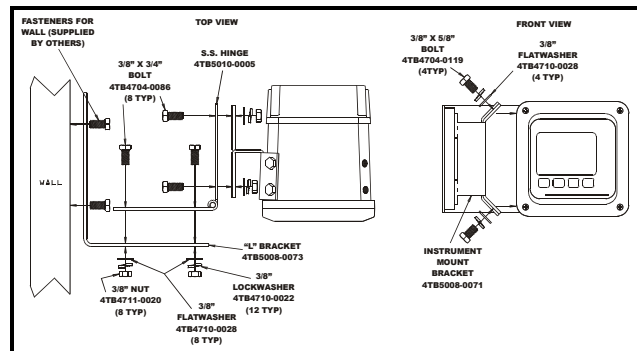

Figure 6 – Hinge Mounting Detail

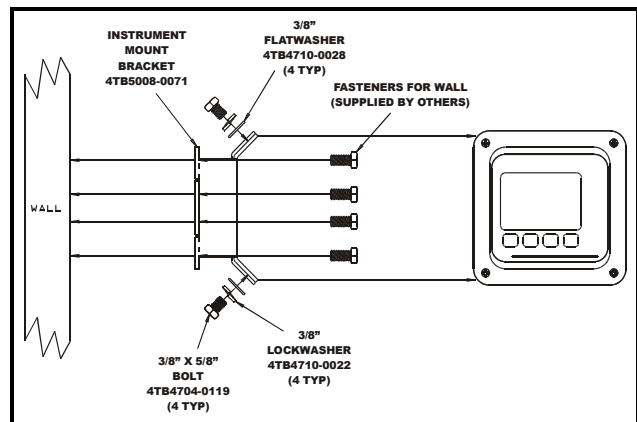

Figure 7 – Wall Mounting Detail

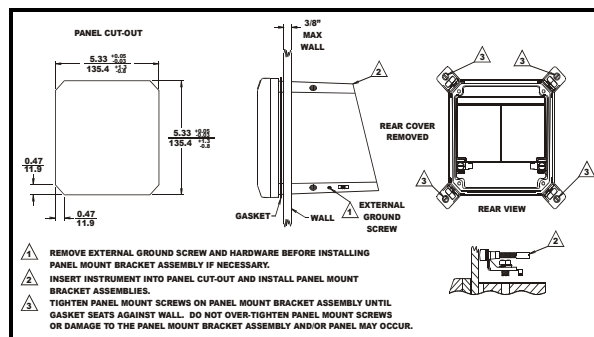

Figure 8 – Panel Mounting Detail

# ELECTRICAL CONNECTIONS

**Warning.**  
 Use this equipment only in those classes of hazardous locations listed on the nameplate. Uses in other hazardous locations can lead to unsafe conditions that can injure personnel and damage equipment.

The bus powers the transmitter; thus, power and fieldbus signals share the same pair of wires. Separate conduit for power and sensor wiring is encouraged. Prior to entering the instrument housing, terminate rigid conduit and install a short length of flexible conduit to reduce stress to the housing. Signal wiring must not come in close proximity to high-power equipment or to cabling from such equipment. Wiring must be in accordance to the applicable local codes and fieldbus requirements (see Supplementary Documentation). Bus cabling must conform to IEC 61158-2.

The terminal blocks located in the rear of the transmitter accept wire sizes from 12 to 24 AWG. Pin-style terminals should be used for all connections. The terminal block label identifies all electrical connections and should be followed when wiring the transmitter. Observance to polarity is not required; however, polarity indications have been provided for consistence. Voltage requirements are listed in the Specifications and must be observed. Ensure the power supply that provides bus power is compliant with IEC 61158-2.

Normal grounding practice is to terminate all grounds in the control room side, in which case the field side of the screen should be adequately protected to avoid contact with metallic objects. For bus-powered systems, the grounding of the shield should be close to the power supply unit. For IS systems, the grounding should be at the safety barrier earth connection. The transmitter case should be grounded. Ground connections are provided internally (in the terminal compartment) and externally.

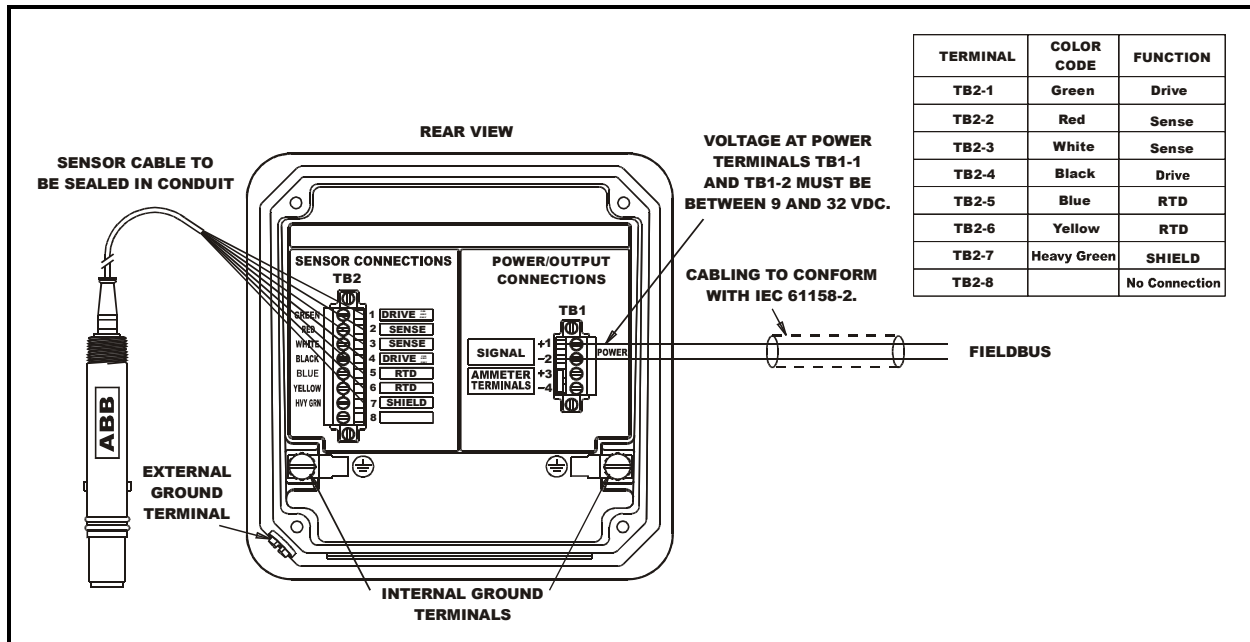

Figure 9 – Sensor and Power Wiring

---

## ... ELECTRICAL CONNECTIONS

---

To ensure fault-free communication, the bus must be properly terminated at both ends. Only approved bus terminators must be used for intrinsically safe circuits. The specific noise immunity and emitted interference are only guaranteed when bus screening is fully effective (e.g., ensuring that screening is maintained through any existing junction boxes.) Appropriate equi-potential bonding must be provided to avoid differences in potential among the individual plant components.

Two hundred fifty-five addresses per segment are allowed.

- Addresses from 0 to 15 are reserved for group addressing and Data Link (DL) use.
- Addresses from 16 to 247 are reserved for devices.
- Addresses from 248 to 251 are non-visitor addresses used as defaults for devices using address assignments.
- Addresses from 252 to 255 are visitor addresses used for temporary (handheld) devices.

The number of transmitters or devices that can be connected to a bus is also dependent on the transmitters'/devices' power consumption, the type of cable, number of spurs, total cable length of the bus, and intrinsically safe requirements.

The table below lists some considerations that have been identified by the FOUNDATION Fieldbus Organization.

Parameters	Specification	
Data Rate	31.25 Kbits/s	
Type	Voltage	
Topology	Bus/tree	
Bus Power	DC	
Intrinsically Safe	No	Yes
Max Nr of devices (1)	32	6
Max cable length (2)	1900 m	
Max spurs length (3)	120 m	

Notes:

- 1) The number of devices is dependent on several physical parameters (e.g., power consumption, bus cable, device IS parameters, etc.).
- 2) Length includes bus and all spurs lengths.
- 3) The maximum Spur length with one device is 120 m; 30 m less for each addition device.

For further information on FOUNDATION Fieldbus installations, see Supplementary Documentation list at the beginning of this manual.

---

## LOCAL HMI OPERATING PROCEDURES

---

The TB82EC Four-electrode Conductivity FF Transmitter has seven main operating modes: Measure, Calibrate, Output/Hold, Configure, Security, Secondary Display and Utility. Within each mode, several programming states containing functions specific to the related mode are available.

Using a patented HMI, programming or accessing information from the transmitter's front panel is quick and easy. The LCD contains nine regions that provide the user with information on the process variable, engineering units, mode of operation, fault indication, secondary variable, and function key assignment (see Figure 2). The primary process variable is displayed in the three and one-half digit region. The Engineering Unit region supports this region. These display regions are active in all modes of operation; however, some programming states also use these regions for data entry.

The secondary variable is displayed in the six-character region. This display region is used for displaying secondary and fault information in the Measure Mode of operation and textual prompting in all other modes of operation.

Due to the limited number of characters supported by the secondary display, many of the prompts take the form of a text abbreviation (see Glossary of Programming Text Prompts for a list of abbreviations.) The secondary display region is active in all modes of operation.

A five-button, tactile keypad is located on the front panel of the instrument. Four of the buttons are embossed to easily show their location. A fifth, hidden button located at the top, center of the keypad provides access to functions that are infrequently used. The embossed keys do not have a pre-assigned function. Icons are energized over the key to indicate their function. If a key does not have an icon energized above its location, this key does not have a function and will not initiate an action when pressed. The first table below lists all key functions.

The Measure Mode is the normal operating mode of the transmitter and is the default mode upon power-up. The Measure Mode is the starting point for entry into other modes of operation. Each mode contains a unique set of transmitter functions or states. These modes and their related functions are listed in the second table below.

Icon	Key Function
Exit to MEASURE	Escapes back to the Measure Mode from all other modes or programming states of operation. This function is not available in the Measure Mode.
FAULT Info	Accesses information on diagnostic problem or error conditions. Displays this information as a short text string and code. This function is only available in the Measure Mode.
SELECT	Selects the mode or programming state of operation shown in the secondary display region.
ENTER	Stores configured items and data into memory.
NEXT	Increments through a series of programming states.
YES	Affirms the action that is about to take place.
NO	Denies the action that is about to take place.
MENU	Increments through the modes of operation.
▲	Increases numeric values or moves through a series of parameters.
▶	Moves the flashing data entry value one space to the right.
▼	Decreases numeric values or moves through a series of parameters.

Mode	Function
Measure	Used to display the process and secondary variables – the normal operating mode for the transmitter.
Calibrate	Used to calibrate input devices (i.e., the process and temperature sensors).
Out/Hold	Used for viewing critical parameters found in the Transducer and Analog Input Function Blocks.
Configure	Used to configure transmitter functions such as temperature compensation, temperature sensor type, and measurement electrode type.
Security	Used to enter password protection for the Calibrate and Configure Modes of Operation.
Display	Used to select the variable that will be shown in the secondary display region when the transmitter is in the Measure Mode of Operation.

## MEASURE MODE

The Measure Mode is the normal operating mode of the transmitter. In this mode, the process variable, fault conditions, and secondary display information are displayed. From the Measure Mode, other modes of operation and fault information can be accessed.

When a user enters an operating mode or state and does not return to the Measure mode as the final step, the transmitter automatically returns to the Measure Mode of operation after 20 minutes of unattended use.

The process variable is shown in the primary display area. The value of this variable is dependent on the configured analyzer, temperature compensation type, temperature value, and sensor signal. The engineering units for the process variable are dependent only on the configured analyzer. The table below lists the analyzer types and corresponding engineering units.

Analyzer Type	Engineering Unit
Conductivity	mS/cm, $\mu$ S/cm
Concentration	ppm, ppb, %, User Defined Text, No Units

The secondary display has the ability to show a large variety of information. Since the display area only has six characters, only one item can be shown at any

given time. Typically, this region will be used for displaying the process temperature in degrees Celsius; however, it can be changed to display the process temperature in degrees Fahrenheit, sensor group, sensor type, conductivity value and solute name for a concentration analyzer type, and firmware revision.

Fault information can only be accessed from the Measure Mode. During a fault condition, the FAULT warning icon above the process variable display region will blink. The FAULT Info key will also become active and can be used to obtain a text description of the fault condition. Pressing the FAULT Info key progressively moves from one fault to the next until all faults have been shown. Once all faults have been interrogated, the FAULT icon stops blinking and will remain energized until all faults have been removed. If a new fault condition is detected, the FAULT icon will begin to blink to inform the user of the newly detected condition.

The MENU key provides access to all other modes of operation. Pressing this key moves the transmitter to the next operating mode. Visual feedback is provided in two manners: the mode indication arrow moves to the next mode of operation (e.g., Calibrate) and the secondary display shows the text string representing the new mode of operation (e.g., CALIBR).

## CALIBRATE MODE

The Calibrate Mode of Operation provides the ability to calibrate the sensor and temperature inputs. These functions include process variable, temperature, edit, and reset calibration. Figure 10 shows the Calibrate States and key assignments for each state.

### Process Variable Calibrate State

The Process Variable Calibrate State contains one calibration procedure. This calibration procedure is a smart one-point calibration routine that allows for single point and dual-point calibration. By initiating calibrations at two different conductivity values having ample separation, the transmitter automatically adjusts the offset and slope in order to obtain the best sensor performance. Since this routine only uses the most recent calibration data, calibration can be conducted throughout the sensor's life thus ensuring consistent sensor performance. If an incorrect calibration has been entered, the Reset Calibrate State provides the ability to return the transmitter calibration to factory settings.

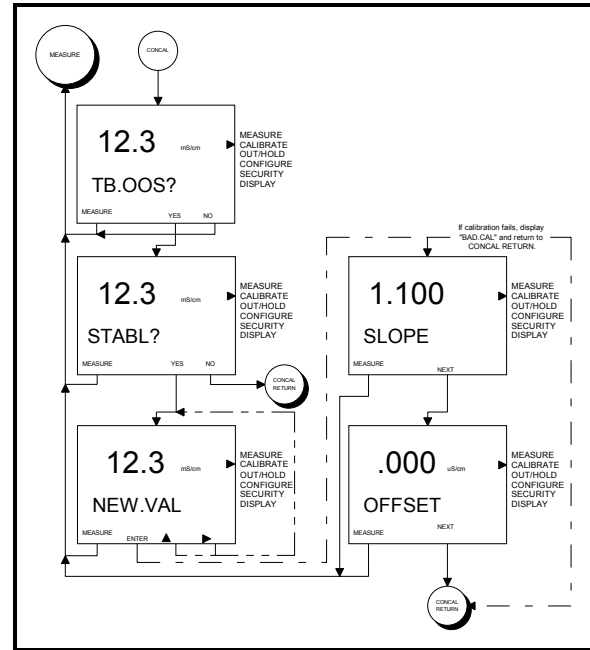
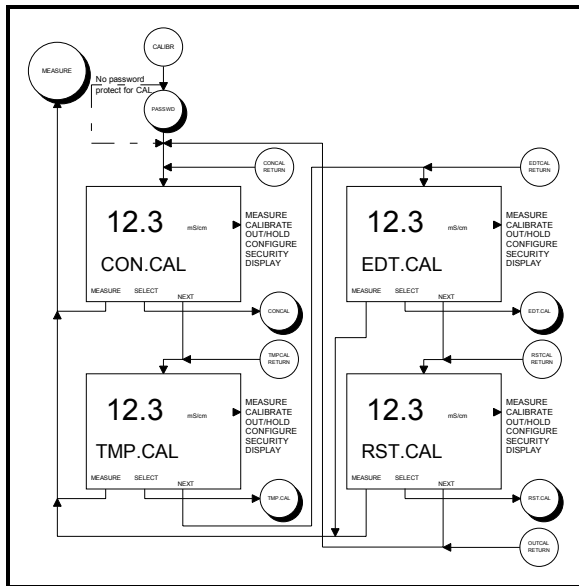

**Figure 11 – Screen Flow Diagram for Process Variable Calibrate States of Operation**

Invalid calibration values will generate the text string BAD.CAL (i.e., Bad Calibration), and the calibration value will not be accepted. If the values are valid, the Efficiency (shown as a dimensionless value) will be shown. Pressing the NEXT key displays the Offset value. At this point, the user can return to the Process Variable Calibrate State by pressing the NEXT key or to the Measure Mode by pressing the Exit to MEASURE key.

### Temperature Calibrate State

The Temperature Calibrate State is a smart calibration routine that allows for both single- and dual-point calibration. By calibrating the temperature at two points that are at least 20°C apart, the transmitter adjusts the offset and slope. Since this routine only uses the most recent calibration data, calibrations can be conducted throughout the sensor's life to ensure accurate measurement of the temperature. If an incorrect calibration has been entered, the Reset Calibrate State can restore the calibration to factory settings.



**Figure 10 – Screen Flow Diagram for Calibrate Mode of Operation.**

Since the transmitter can be configured as a Conductivity or Concentration analyzer, the smart one-point calibration routines will automatically set the units of calibration to be the same as those for the measured process value. Thus, a Conductivity Analyzer type uses conductivity units and a Concentration Analyzer type uses the user-defined units set in the Configure Mode.

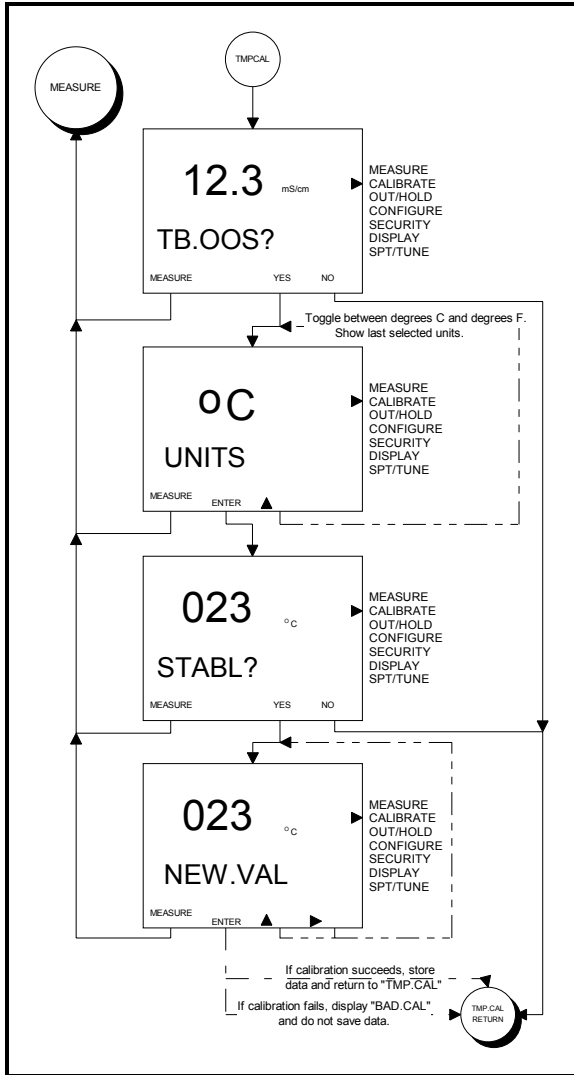

Figure 12 – Screen Flow Diagram for Temperature Calibrate State of Operation

### Edit Calibrate State

The Edit Calibrate State allows a user to manually adjust the sensor and temperature slope and offset values. Though this function may not be suitable for many applications, the Edit Calibrate State facilitates quick and easy access to these calibration values for troubleshooting purposes and to make separate adjustments to process variable and temperature data.

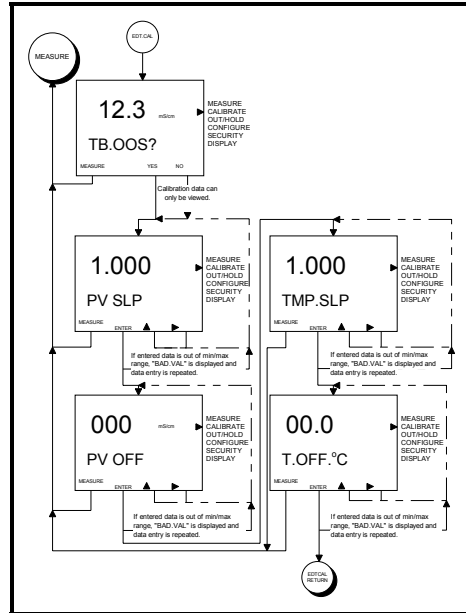

Figure 13 – Screen Flow Diagram for Edit Calibrate State of Operation

### Reset Calibrate State

The Reset Calibrate State sets the sensor and temperature calibration data to factory values. This state purges calibration history and should be initiated before calibrating a new sensor.

When interrogating the calibration values after a reset has been performed, the slope and offset values for both the process and temperature sensors will be set to 100%/1.000 and 000  $\mu\text{S}/\text{cm}/000\text{C}$ , respectively.

#### \* Note

The Reset Calibrate State will reset all calibration values; therefore, the process sensor and temperature sensor will require calibration after performing the Reset Calibrate procedure.

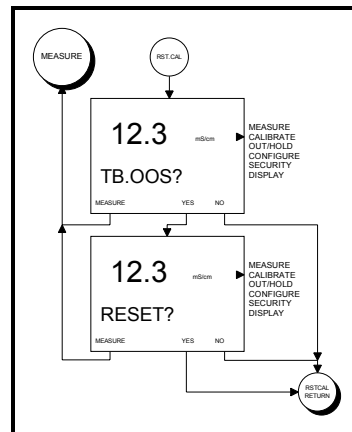

Figure 14 – Screen Flow Diagram for Reset Calibrate State of Operation

## OUTPUT/HOLD MODE

The Output/Hold Mode of Operation provides the ability to view a limited number of Transducer Block (TB) and Analog Input (AI) Function Block parameters. Fieldbus Foundation requirements prevent local adjustments using the HMI of the transmitter for function block parameters other than those located in the TB. Parameter viewing is limited to the TB Process Variable Range, AI Block mode status, AI Output Value, AI Field Value, and AI Process Value.

The TB Range State contains the process value low and high range limits. These represent the range limits used to define the Field Value.

The AI Block information shows the current mode (i.e., Out of Service – OOS, Auto, or Manual) of the specified function block (i.e., AI1 or AI2). For in service blocks, information for the Output, Process and Field Values is shown. If the block is out of service, the Process and Field Values will contain the last values written to them when the block was in service. If the block was never in service, these parameters will be zero.

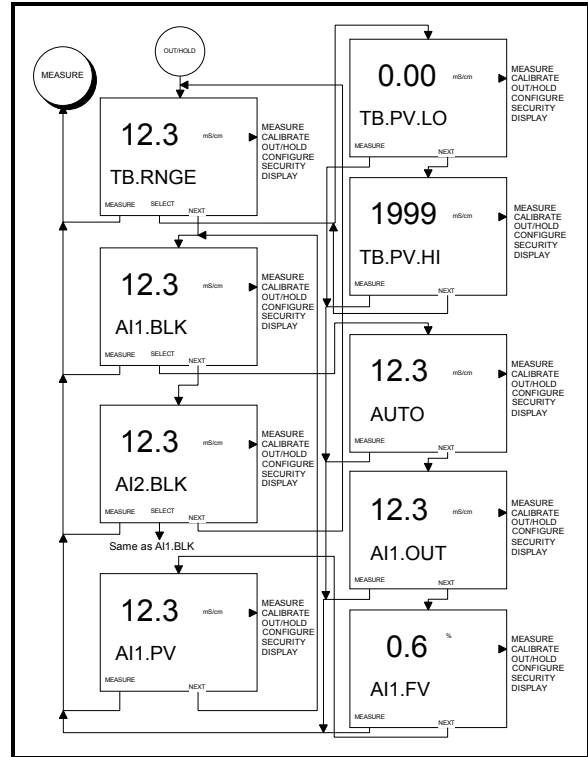

**Figure 15 – Screen Flow Diagram for Output/Hold Mode and States of Operation**

## CONFIGURE MODE

The Configure Mode of Operation establishes the operating parameters of the transmitter. These parameters include analyzer type, temperature sensor type, temperature compensation type, and diagnostic functionality.

Upon selecting the Configure Mode at the local HMI, a query to Modify or View the configuration will be presented. The Modify Configure State enables analyzer options to be set and saved into memory. To access the Modify State, the Transducer Block must be put Out Of Service either from the local HMI upon entry into the Modify State or from a remote configuration tool.

Since the Modify State can be secured, the configuration of the transmitter can be viewed using the View Configure State without violating secured settings. To provide quick and easy access to edit transmitter parameters from the View Configure State, a Hot Key function provides immediate access to the viewed parameter using the ENTER key. If the Modify Configure State is secured, the security code will be requested before entering into the Modify Configure State.

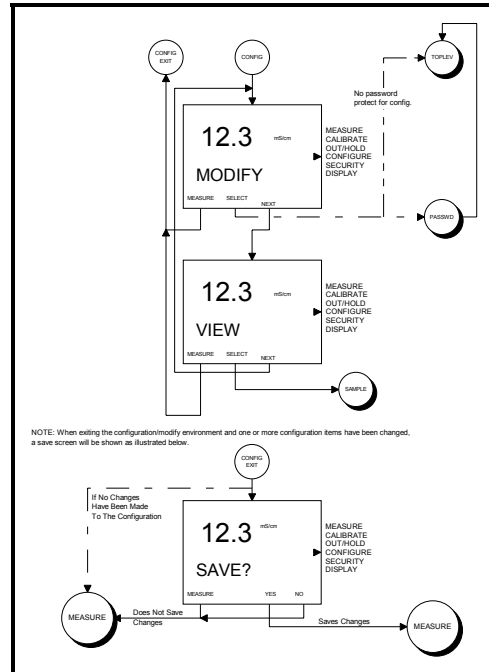

**Figure 16 – Screen Flow Diagram for Modify/View and Save States of Operation**

Any changes to the transmitter configuration must be saved. Pressing the Exit to MEASURE key prompts the user to "SAVE?" their changes. Pressing the YES key saves the new configuration and returns the transmitter to the Measure Mode. The NO key discards the changes and returns the transmitter to the Measure Mode. Upon exiting from the Modify state, the TB mode is returned from Out-Of-Service to its previously set state.

The Modify Configure State contains all the available settings that establish the functionality of the transmitter. Upon receipt of the transmitter, the default configuration (unless otherwise specified by the customer when ordering the transmitter) will be active once the transmitter has been powered. See the Configuration Data Sheet at the end of this manual for default configuration settings. Before installing the transmitter, the configuration should be modified to reflect the final installed application. The Table below describes each of the Modify Configure States and their function.

State	Function
ANALZR	Used to define the type of analyzer. Choices include Conductivity and Concentration.
TMP.SNS	Used to define the type of temperature sensor. Choices include None, Pt100, 3k Balco, and 4.75 kohm Standard Network.
TC.TYPE	Used to define the type of temperature compensation. Choices include Manual (0.1N KCl based), and Automatic, which can be set to one of the following: Standard KCl (0.1N KCl based), Temperature Coefficient (%/°C), 0 to 15% NaOH, 0 to 20% NaCl, 0 to 18% HCl, 0 to 20% H <sub>2</sub> SO <sub>4</sub> , .Pure Water Neutral, Pure Water Acid, Pure Water Base, and User-Defined.
DIAGS	Used to set the sensor diagnostics ON or OFF.

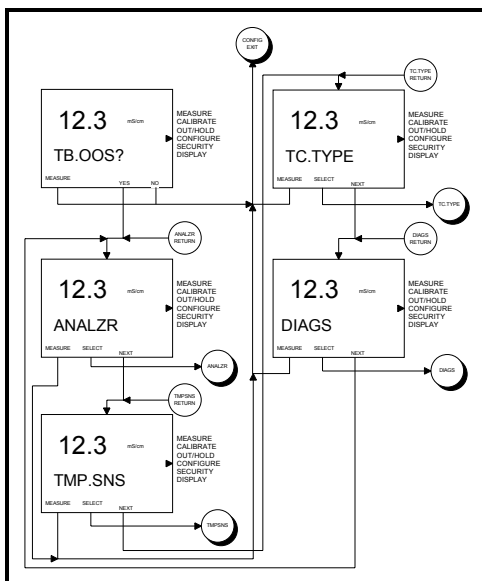

Figure 17 – Screen Flow Diagram for Modify Configure States of Operation

## Analyzer State

The Analyzer State sets the type of measurement (i.e., Process Value) and sensor type. The measurements are conductivity and concentration. The Conductivity setting displays the Process Value using the engineering units of either mS/cm or  $\mu$ S/cm. The Concentration setting converts the measured temperature compensated conductivity to a solute weight percentage using either one of the canned concentration algorithms or a user-defined curve fit. Concentration units are set to percent or can be separately defined for a user-defined curve fit.

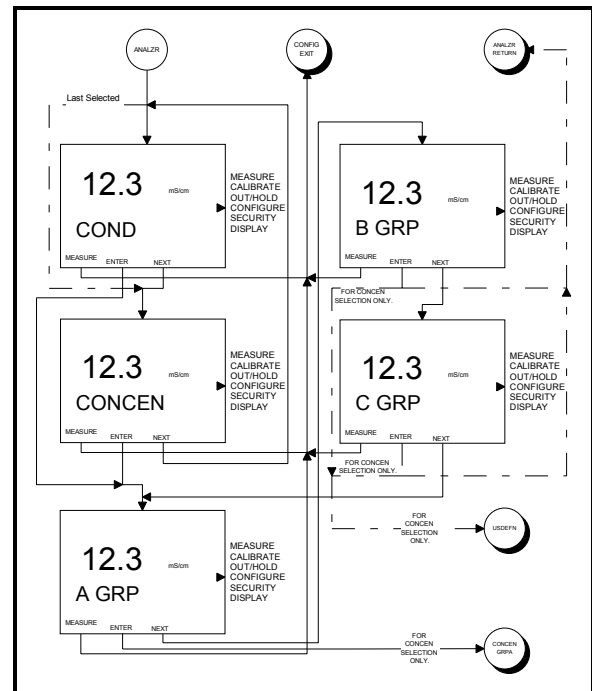

Figure 18 – Screen Flow Diagram for Analyzer States of Operation

The Conductivity Analyzer State contains three choices for four-electrode sensor groups: A, B, and C. The Sensor Group must be entered and correspond with the conductivity sensor being used with the transmitter. The measurement range for each sensor group is listed in the Specification Section. Since ABB four-electrode Conductivity Sensors have unique cell constants that are defined by the physical orientation, surface area of the electrodes, and the measured solution voltage set by the electronics of the transmitter, only ABB TB4 sensors are recommended for use with the TB82EC FF Transmitter.

The Concentration State converts conductivity values to concentration units. This state applies temperature-compensated conductivity measurements to a pre-defined or user-defined

function that converts the conductivity measurements to concentration values. All concentration values have a fixed decimal point location.

The Concentration State provides the following pre-defined concentration algorithms:

- 0 to 15% Sodium Hydroxide (NaOH)
- 0 to 20% Sodium Chloride (NaCl)
- 0 to 18% Hydrochloric Acid (HCl)
- 0 to 20% Sulfuric Acid (H<sub>2</sub>SO<sub>4</sub>)

These pre-defined configurations are based on data contained in the International Critical Tables.

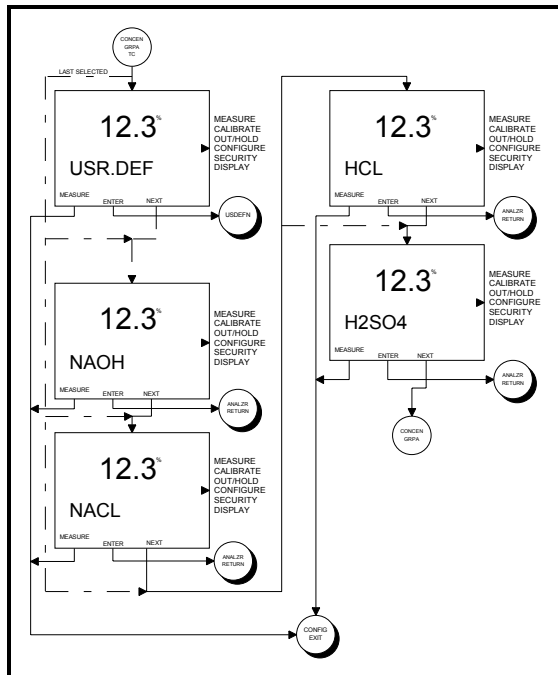
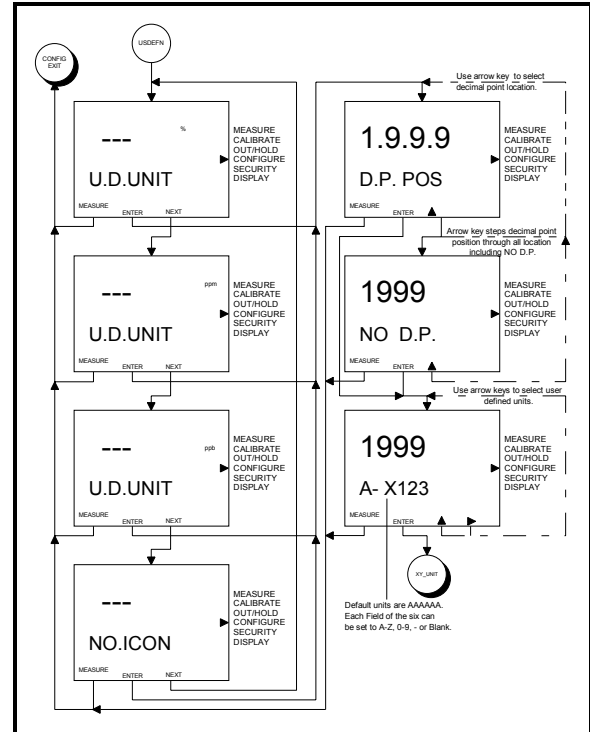

**Figure 19 – Screen Flow Diagram for Canned Concentration States of Operation**

The user-defined configuration provides capability for selecting an Engineering Unit icon, decimal point position, custom text description, and six-point curve fit. The Engineering Unit icon options include percent (%), parts-per-million (ppm), part-per-billion (ppb), and no Engineering Unit icon.

The six-point curve fit sets the end-point and break point values of the desired conductivity-to-concentration conversion. The end-point values define the full-scale output range, and the break point values identify the transition points between the five line segments defining the conductivity-to-concentration curve.

To define the end-point and break point values, a plot of temperature-compensated conductivity against solute concentration must be divided into five line segments that best approximate the shape of the conductivity-to-concentration curve. The beginning of the first and end of the fifth line segment identify the end-points of the approximation and output range.



**Figure 20 – Screen Flow Diagram for User-Defined Concentration State of Operation.**

To illustrate the use of the User-Defined Concentration State, data for 0 to 45% NH<sub>4</sub>NO<sub>3</sub> is plotted showing the various break and end-points. As seen by this example, the conductivity-to-concentration curve is a non-linear function, which has been divided into five line segments. The end-point values represent point numbers 1 and 6, while the break point values represent point numbers 2 through 5.

Point Number	Ammonium Nitrate Conductivity (mS/cm)	Ammonium Nitrate Concentration (%)
1	0	0
2	55	5
3	105	9
4	195	16
5	310	28
6	400	45

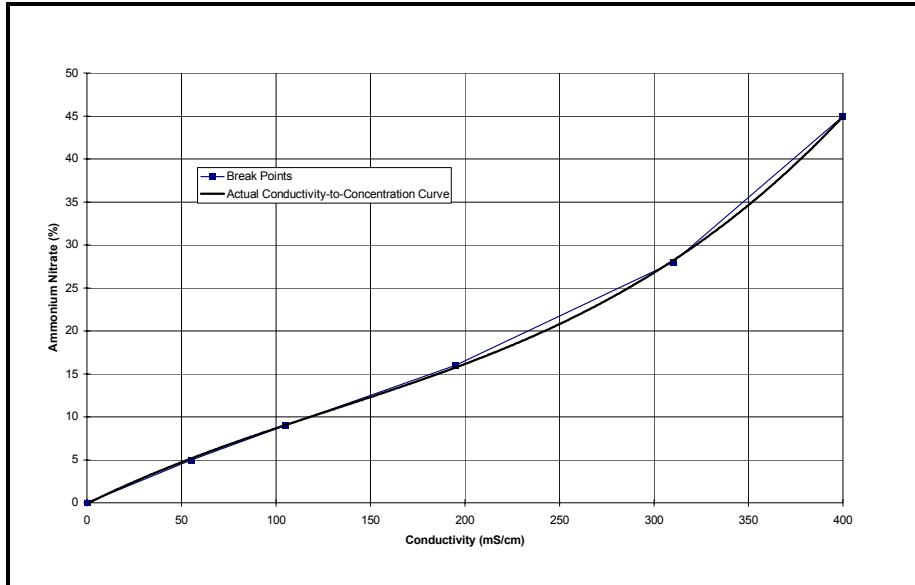

Figure 21 – Conductivity-to-Concentration Break Point Determination

### Temperature Sensor State

The Temperature Sensor State configures the transmitter for use with a Pt100, 3 kohm Balco, 4.75 kohm Network or no RTD (NONE).

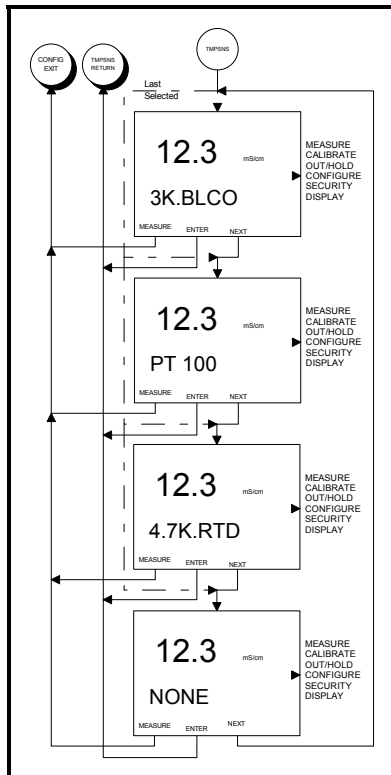

Figure 22 – Screen Flow Diagram for Temperature Sensor State of Operation

### Temperature Compensation State

Temperature has a marked effect on the conductance of solutions. The effect is generally non-linear and dependent on the particular ionic species and their concentration.

The TB82EC FF Transmitter contains a number of preprogrammed correction algorithms that compensate the effect of temperature on conductivity to a reference temperature of 25°C. Thus, the displayed and transmitter process value will be accurate and stable when the process temperature varies.

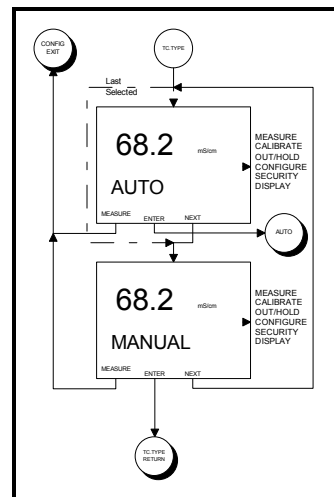

Figure 23 – Screen Flow Diagram for Temperature Compensation State of Operation.

The options for temperature compensation are grouped into two sets: MANUAL and AUTO (Automatic). MANUAL temperature compensation contains no additional options and is locked to a specific process temperature independent of the selected temperature sensor. If a different fitted temperature is desired, the new temperature can be

adjusted by completing a temperature calibration to the desired temperature value.

The AUTO compensation options are sensor group dependent and use the measured temperature value. AUTO compensation algorithms include the following Temperature Compensation States:

State	Function
STD.KCL	Standard Potassium Chloride (KCl). Compensation is 0.1N KCl based. Available for all sensor groups.
TC.COEF	Temperature Compensation Coefficient. Compensation is based on a percent change of the conductivity at the reference temperature per degree Celsius. Available for all sensor groups.
NAOH	Sodium Hydroxide. Compensation is 0 to 15% Sodium Hydroxide (NaOH) based. Only available for Sensor Group A.
NACL	Sodium Chloride. Compensation is 0 to 20% Sodium Chloride (NaCl) based. Only available for Sensor Group A.
HCL	Hydrochloric Acid. Compensation is 0 to 18% Hydrochloric Acid (HCl) based. Only available for Sensor Group A.
H2SO4	Sulfuric Acid. Compensation is 0 to 15% Sulfuric Acid (H <sub>2</sub> SO <sub>4</sub> ) based. Only available for Sensor Group A.
NEUTRL	Pure Water – Neutral Salt. Compensation accounts for the effect of pure water with a trace salt factor applied. Only available for Sensor Group C.
ACID	Pure Water – Neutral Salt. Compensation accounts for the effect of pure water with a trace acid factor applied. Only available for Sensor Group C.
BASE	Pure Water – Neutral Salt. Compensation accounts for the effect of pure water with a trace base factor applied. Only available for Sensor Group C.
USR.DEF	User-Defined. Compensation is defined as a ratio of uncompensated conductivity over compensated conductivity for a specific set of temperatures. Available for all sensor groups.

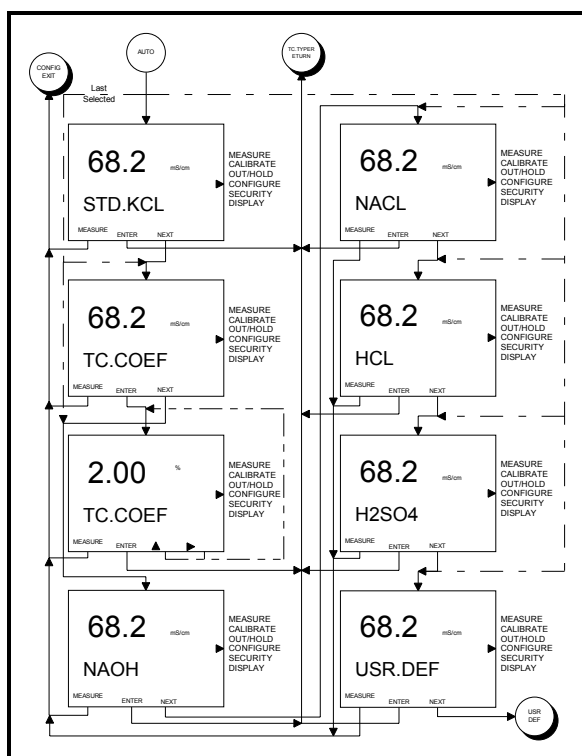

Figure 24 – Screen Flow Diagram for Automatic Temperature Compensation States of Operation

The User-Defined temperature compensation option requires uncompensated conductivity data from the reference temperature (typically 25°C) to the maximum process temperature on a representative sample of process solution. With this data, the ratio of uncompensated conductivity to conductivity at the reference temperature is calculated. These ratios are then plotted against the temperature.

To illustrate the use of the User-Defined Temperature Compensation State, an example of a possible conductivity data set is shown below. Once the data is plotted, the non-linear plot is segmented into five linear sections. The break points, which are listed as the first and third column in the table, are used for the data that is entered into the User-Defined Temperature Compensation States.

Temperature (°C)	Uncompensated Conductivity (mS/cm)	Conductivity Ratio (K/K <sub>STD</sub> )
0	7.21	0.70
25	10.3	1.00
50	12.25	1.19
75	12.97	1.26
100	12.82	1.24
200	9.06	0.88

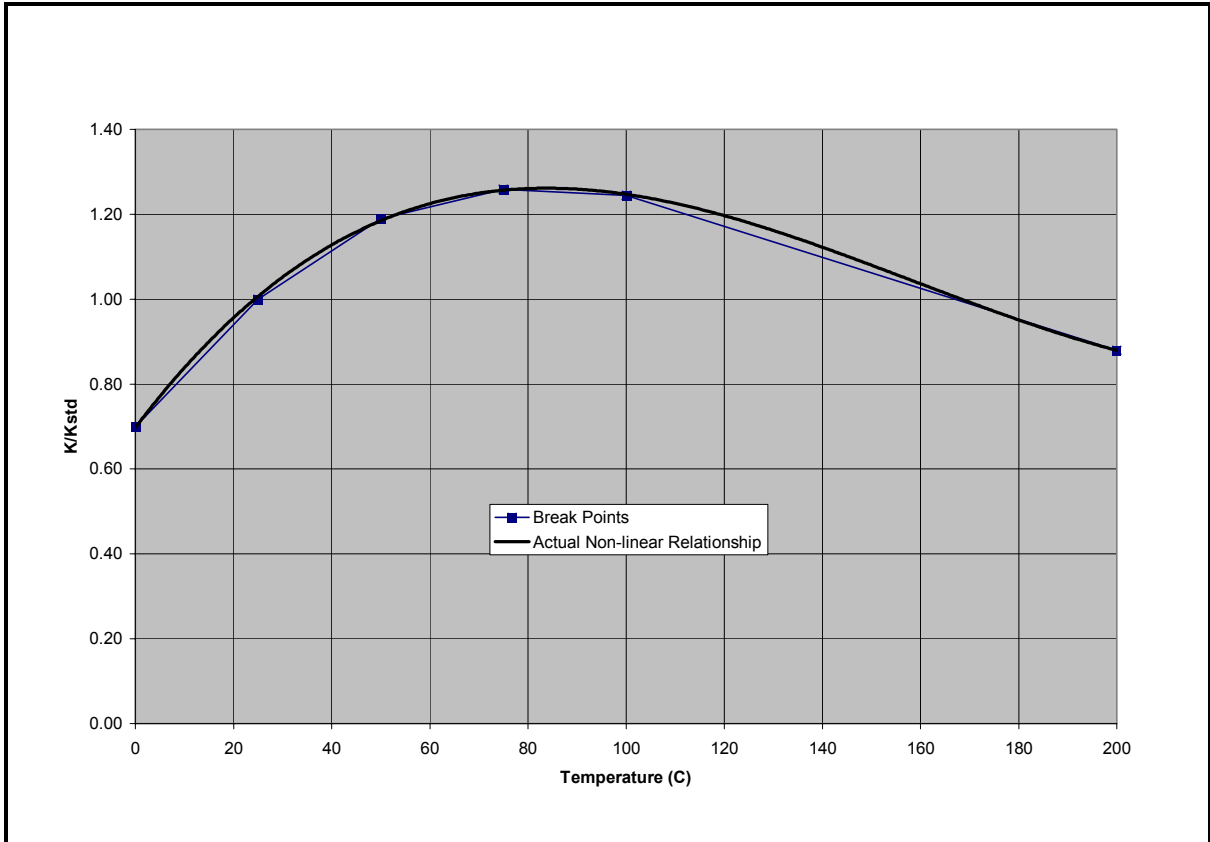

Figure 25 – User-Defined Temperature Compensation Break Point Determination

### Diagnostic State

The Diagnostic State contains a toggle to enable (ON) or disable (OFF) built-in dirty sensor diagnostic detection. Dirty sensor detection monitors the drive level necessary to make the conductivity measurement. As resistive coats build on the sensor, the drive level will increase. At an internal set level, the transmitter will issue a detected fault condition to indicate the sensor requires cleaning.

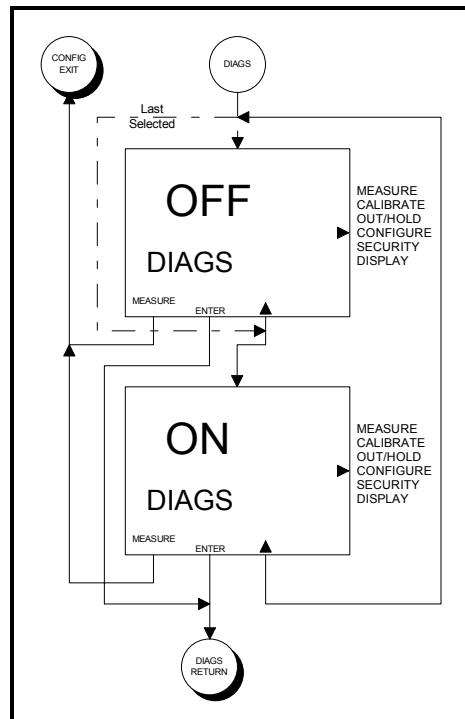

Figure 26 – Screen Flow Diagram for Diagnostic State of Operation

## SECURITY MODE

The Security Mode of Operation establishes password protection against unauthorized changes to transmitter functions. Password protection can be assigned to the Calibrate and Configure Modes of Operation. Additional Security functions are available in the Resource Block and will be discussed in Resource Block Section.

The Security Mode of Operation provides password protection of critical operating environments. When in the Security Mode, toggling the primary display between security OFF and ON sets password protection for the mode displayed in the secondary display area. When one or more modes have been secured, the security password must be correctly entered at the Password State before entry into the Security Mode is allowed. One password assignment applies to all secured modes.

To prevent misuse of the security function by a malicious user, the Security Mode can be password protected without securing one or both other modes of operation.

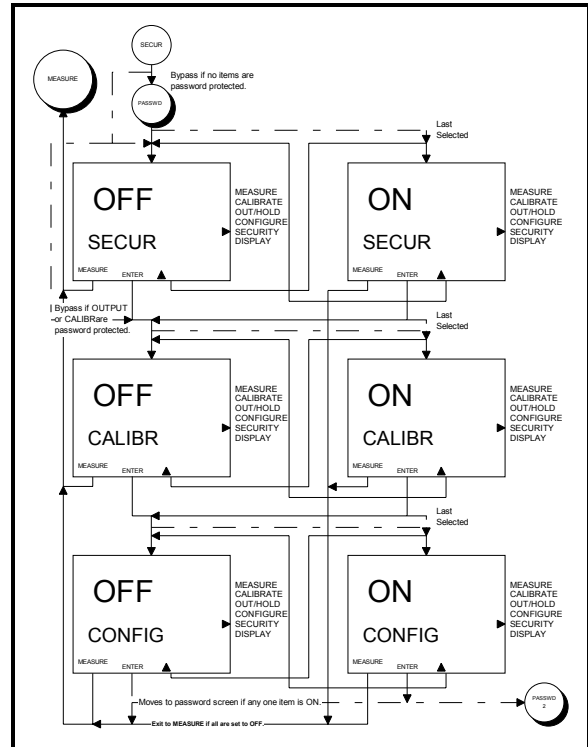
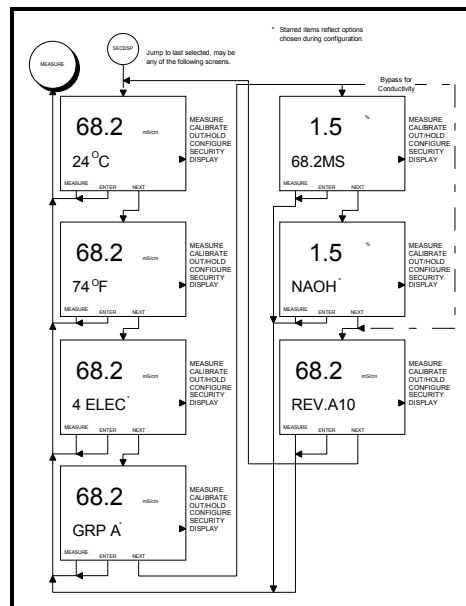

**Figure 27 – Screen Flow Diagram for Security Mode of Operation**

## SECONDARY DISPLAY MODE

The secondary display region can be configured to display one of a multitude of process, sensor, or transmitter parameters in the Measure Mode of Operation. The Secondary Display Mode provides the ability to view these parameters or to set one parameter active in the Measure Mode. These parameters include temperature in °C, temperature in °F, sensor type, sensor group, compensated conductivity (concentration analyzer type only), user-defined text description (concentration analyzer type only) and software revision. The NEXT key cycles through the parameters, while the ENTER key sets the displayed parameter as the secondary display value when in the Measure Mode.

For temperature parameters, a superscript 'M' at the end of the temperature value indicates that the transmitter's Temperature Compensation State is set to Manual.



**Figure 28 – Screen Flow Diagram for Secondary Display Mode of Operation**



---

## Transmitter Identification (FF.ID) State

---

There are several ways to identify a transmitter in the network, and more precisely, three different addressing levels are used to characterize a FOUNDATION Fieldbus device.

The most important is the Device Identifier (i.e., DEV\_ID). This identifier is a string of 32 characters and provides a unique FOUNDATION Fieldbus device address by incorporating a manufacturer code, device type code, device type identification, and sensor serial number.

Since this identifier must have a unique value, the FF.ID state is password protected. To access to this screen, a user must contact the factory for further instructions.

---

## Damping State

---

The Damping State applies a lag function on the process input. The Damping State values affect Process and Secondary Value 4 (Function Generator) transmitted values. Application of the FV\_VALUE in the AI blocks will apply an additional damping on the mapped variable. To adjust the Damping State, the password **367** must be entered when requested by the transmitter.

---

## TRANSMITTER'S FIELDBUS FUNCTIONALITY

---

The Data Link Layer of Fieldbus FOUNDATION Protocol defines three types of device:

- Basic device
- Link Master
- Bridge

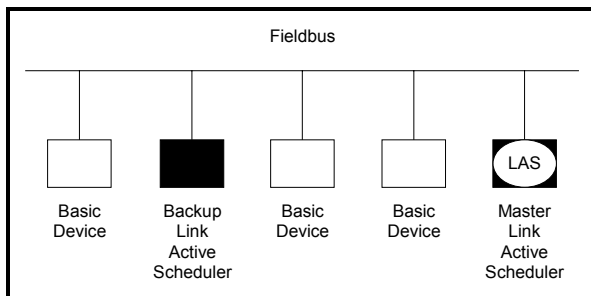

The **Link Master** device is typically the Link Active Scheduler (LAS); thus, it is responsible for organizing the activity/communication on the fieldbus. **Basic Devices** do not have the capability to become the LAS. Bridges are used to interconnect individual fieldbuses to create larger networks.

A Fieldbus may have multiple Link Masters. If the primary LAS device fails, one of the other Link Masters will assume LAS responsibilities. In this manner, the operation of the fieldbus link will be maintained. **The TB82EC Foundation Fieldbus Transmitter does not have the capability of being a backup LAS device.** Below is a complete list of the transmitter fieldbus functionality:

- **Standard Resource Block:** This block contains the description of the transmitter characteristics.
- **Standard Analog Input Function Block:** Two Analog Input Function Blocks are available for control loop operations.
- **Enhanced Transducer Block with calibration capability:** This block contains configuration parameters, calibration functions, and diagnostic

data.

The transmitter allows different types of communication services as described by the Fieldbus Message Specification (FMS). These FMS services permit a User Application to send serial messages to each device across the fieldbus network using a standard message format. FMS describes the communication services, the format of the message, and the protocol behaviors required to build messages for the User Application. A pictorial illustration of this methodology is shown below.

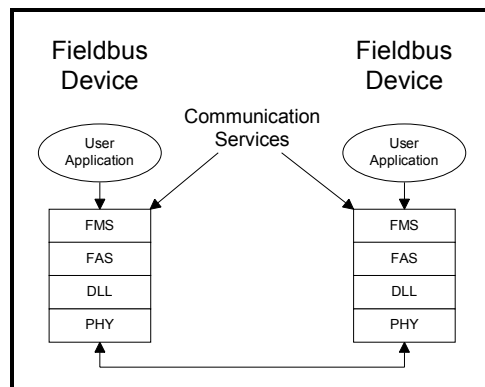

The **FMS Services** supported by the transmitter are listed below:

- **Initiate** - used to establish the initial communication.
- **Abort** - used to release the communication.
- **Status** - used to read a device status.
- **Identify** - used to read vendor, type and version information.
- **Read variable** - used to read a variable.
- **Write variable** - used to write a variable.
- **Get Object Dictionary** - used to read an Object Dictionary.

The transmitter provides support for all **Virtual Communication Relations (VCR)**. These relationships represent the rules for communication between objects connected on the fieldbus. Below is a brief description of these communication relationships.

**Client/Server VCR Type**

This type of communication is used for configuration and maintenance purpose and includes functions such as setting parameter access, changing parameter values, alarm acknowledgement, uploading and downloading parameter values. In other words, this type of communication is used for queued, unscheduled, user initiated, one to one communication between devices on the fieldbus. The LAS is responsible for distributing and assigning a Pass Token (PT) to the devices on the fieldbus. The device that has the token can send a request to another device. The requesting device is called the **Client** and the device that receives the request is called the **Server**.

**Report/Distribution VCR Type**

This type of communication is typically used by fieldbus devices to send alarm notifications or trend reports to a Master Device. This type of communication is a queued, unscheduled, user initiated communication between one and many other devices.

**Publisher/Subscriber VCR Type**

This type of communication is used for Process Control purposes. When a device has been scheduled to send data, this data is **Published** or broadcasted onto the fieldbus. Devices that wish to receive this Published data are called **Subscribers**. This type of communication is a scheduled and cyclic exchange of data and is used to publish function block inputs and outputs such as process variable and primary output information onto the fieldbus.

Refer to the following figure for a summary of the VCR Types.

<b>FIELDBUS ACCESS SUBLAYER SERVICES</b>		
Client/Server VCR Type	Report/Distribution VCR Type	Publisher/Subscriber VCR Type
Used for Operator Messages	Used for Event Notification and Trend Reports	Used for Publishing Data
<ul style="list-style-type: none"> <li>• Mode Changes</li> <li>• Tuning Changes</li> <li>• Upload/Download</li> <li>• Alarm Management</li> <li>• Access Display Views</li> <li>• Remote Diagnostics</li> </ul>	<ul style="list-style-type: none"> <li>• Send Process alarms to operator consoles</li> <li>• Send trend report for data histories</li> </ul>	<ul style="list-style-type: none"> <li>• Send transmitter PV and SV data to control blocks and operator consoles</li> </ul>
<b>DATA LINK LAYER SERVICES</b>		

---

## DEVICE BLOCKS

---

All variables and parameters of the transmitter are structured in blocks with respect to their assignment of components or functions. This structure is termed the Function Block Application Process (FBAP) and has been designed to support five primary operational characteristics:

1. Configuration and definition of function blocks
2. Configuration of function block links
3. Alert processing
4. Access to information for operator interface, remote operation, diagnostics, and configuration
5. Coordinating function block execution and communication

The basic elements of the FBAP are as follows:

- Block Objects and Parameters
  - Resource Block
  - Transducer Block
  - Function Block (e.g., Analog Input, Analog Output, PID, etc.)
- Link Objects: Allows the transfer of data between blocks as defined by the Virtual Communication Relationship (VCR).
- Alert Objects: Used to communicate alerts and/or events to other devices.
- Trend Objects: Used to maintain a history of values of an individual parameter.
- View Objects: Used to group a subset of operation and configuration data.
- Domain and Program Invocation Objects: Used to support download and upload services.

Blocks are logical groups of device functionality that define a particular application using a common model. In general, blocks process input parameters and events through one or more process algorithms and execution controls in order to produce the expected output parameters and events. Block parameters control the function and execution of the block and are visible over the fieldbus network. Data communicated over the fieldbus is expressed as an "object description". Object descriptions are collected together in a structure called an Object Dictionary (OD) and are identified within the OD by their index. During system operation, block parameters are accessed using an OD index.

Since most plants have many different process control requirements, the type of functions can greatly vary. The Fieldbus Foundation specifications identify a range of function blocks, each addressing a different need. These standard function blocks provide a common structure for defining block inputs, outputs, control parameters, events, alarms, and modes. This common structure can then be easily

used in a wide range of process control and monitoring devices.

**The Resource Block** contains the hardware specific characteristics associated with a device. This block does not have input and output parameters; instead, it contains an algorithm that monitors and controls the general operation of the physical device hardware. For example, the mode of the Resource Block impacts all of the other blocks. Other Resource Block parameters include but are not limited to the manufacturer's name, device name, and serial number. Only one resource block is included per device.

**The Transducer Blocks** connect input and output functions to other function blocks residing in the same device. It interfaces with sensor input hardware and provides a measured value and status to connected function blocks. Transducer Block parameters include but are not limited to sensor type, temperature sensor type, calibration data and routines, calibration date and diagnostic conditions. Usually only one Transducer Block is present per device.

**The Function Blocks** are fundamental for providing the control system behavior. Function Blocks contain input and output parameters and algorithms and can be linked to other function blocks within the same device or to other devices in the fieldbus network. In a single User Application, several function blocks can be available and precisely scheduled in terms of execution.

The Fieldbus Foundation specifications have defined a set of standard function blocks. These are as follows:

- Analog Input (AI)
- Analog Output (AO)
- Discrete Input (DI)
- Discrete Output (DO)
- Proportional/Derivative (PD)
- Proportional/Integral/Derivative (PID)
- Bias (B)
- Control Selector (CS)
- Manual Loader (ML)
- Ratio (RA)

The TB82EC FF Transmitter has one Resource Block, two Analog Input Function Blocks (AI), and one enhanced, custom Transducer Block with calibration capability. The following figure shows block elements for the TB82EC FF Transmitter.

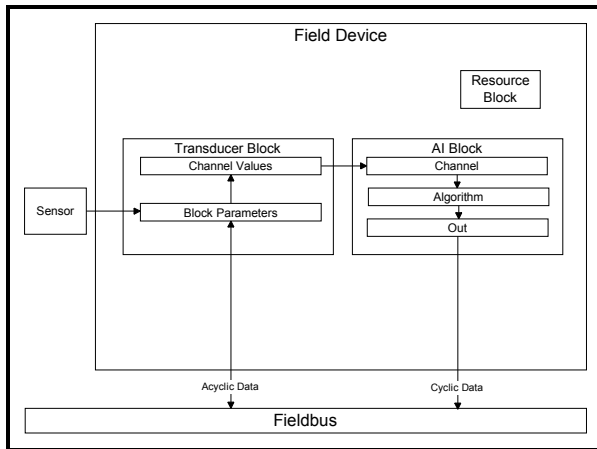

**Figure 30 – FBAP Interaction Diagram**

Function blocks contain Fieldbus Foundation-defined parameters that have been defined by the specifications governing this communications technology. In addition to these parameters, manufacturer-specific parameters are commonly found in most FF devices. The TB82EC FF Transmitter contains several manufacturer-specific parameters in the Transducer Block; however, the Resource and Analog Input Blocks are standard FF blocks.

As also required by the Fieldbus Foundation specifications, the Device Blocks have to satisfy certain defined operating modes. Each block supports the operating modes as described in the table below.

Operational Mode	Blocks		
	Resource	Transducer	Analog Input
Manual (MAN)	N/A	N/A	YES
Automatic (AUTO)	YES	YES	YES
Out of Service (OOS)	YES	YES	YES

The following tables and diagrams contain information regarding block parameters and the structure of these parameters within the block. To assist in the interpretation of this information, the following list of column definitions is provided.

- Index (IDX) – Defines the number corresponding to the sequence of the parameter relative to the beginning of the corresponding block in the object dictionary

Object Dictionary indices at which the blocks start:

- Resource Block – 259
- Analog Input 1 – 350
- Analog Input 2 – 390
- Transducer Block – 430

- Name – Lists the mnemonic character designation for the parameter.
- Description – Provides a short text description of the block parameter.
- Bytes – Lists the memory size of the block parameter.
- Store (ST) – Defines the type of variable for the block parameter. 'S' represents a Static variable that is typically a device parameter such as the type of temperature sensor or variable linearization function. This variable can only be written during an acyclic process and if the AR is Read/Write. Writing to a static parameter changes the static revision of the counter ST\_REV. 'N' represents a Non-volatile variable. Non-volatile parameters are stored internally in the device. This variable is periodically stored to ensure the fixed life of the memory is not shortened. NV\_CYCLE\_T sets the writing interval. This parameter cannot be changed. 'D' represents a Dynamic variable. The value for this variable is calculated by the block and can be read by another block.
- Access Rights (AR) – Defines the access rights of the block parameter. 'R' represents a parameter that only has Read access. 'R/W' represents a parameter that has Read and Write access.
- Default – Lists the default setting for the listed block parameter during initial start up or when a Cold Start is initiated.
- Valid Range – Lists the valid range of selections for the listed block parameter.
- Note – Identifies additional information for the listed block parameter that is available at the end of the block object tables.

The Resource Block includes data and parameters that defined the overall operation of the device. These parameters describe the hardware specific characteristics of the device. The following table lists the Resource Block parameter information.

## RESOURCE BLOCK

IDX	Name	Description	Bytes	ST	AR	Default	Valid Range	Note
0	BLOCK_OBJ	Block Object	62		Mix.			
1	ST_REV	Static Revision	2	S	R	0		
2	TAG_DESC	TAG Description	32	S	R/W			
3	STRATEGY	Strategy	2	S	R/W	0		
4	ALERT_KEY	Alert Key	1	S	R/W	0	1 to 255	
5	MODE_BLK	Target	1	N	R/W	OOS	OOS, Auto	
		Actual	1	D	R	-		
		Permitted	1	S	R/W	OOS, Auto		
		Normal	1	S	R/W	Auto	OOS, Auto	
6	BLOCK_ERR	Block error	2	D	R	-	0 – Off 1 – On	
7	RS_STATE	Resource State	1	D	R	1		
8	TEST_RW	Test	112	D	R/W			
9	DD_RESOURCE	DD Resource	32	S	R			
10	MANUFAC_ID	Manufacturer ID	4	S	R	800 (mfr. ID for ABB)		
11	DEV_TYPE	Device Type	2	S	R	81 (TB82EC FF device type)		
12	DEV_REV	Device Revision	1	S	R	1		
13	DD_REV	DD revision	1	S	R	1		
14	GRANT_DENY	Grant	1	D	R/W	0		
		Deny	1	D	R/W	0		
15	HARD_TYPES	Hardware Type	2	S	R	1	Scalar Input	
16	RESTART	Restart	1	D	R/W			
17	FEATURES	Feature Supported	2	S	R	Reports, Hard Write Lock		
18	FEATURES_SEL	Feature Selected	2	S	R/W	Reports, Hard Write Lock	Reports, Hard Write Lock	
19	CYCLE_TYPE	Cycle Type	2	S	R	Scheduled, Completion of block execution		
20	CYCLE_SEL	Cycle Selected	2	S	R/W	Scheduled, Completion of block execution	Scheduled, Completion of block execution	
21	MIN_CYCLE_T	Min Cycle Time	4	S	R	1600 1/32 msec (50 msec)		
22	MEMORY_SIZE	Memory Size	2	S	R			
23	NV_CYCLE_TIME	Non-Volatile Cycle Time	4	S	R			
24	FREE_SPACE	Free Space	4	D	R	-	0-100 %	

## RESOURCE BLOCK (cont'd)

25	FREE_TIME	Free Time	4	D	R	-	0-100 %	
26	SHED_RCAS		4	S	R/W	640000		
27	SHED_ROUT		4	S	R/W	640000		
28	FAULT_STATE	Fault State	1	N	R		1- Clear 2- Active	
29	SET_FSTATE	Set Fault State	1	D	R/W	1		
30	CLR_FSTATE	Clear Fault State	1	D	R/W	1		
31	MAX_NOTIFY	Max Notifications	1	S	R	8		
32	LIM_NOTIFY	Limit of Notifications	1	S	R/W	Max_Notify	0 to Max_Notify	
33	CONFIRM_TIME	Confirmation Time	4	S	R/W	640000		
34	WRITE_LOCK	Write Locking	1	S	R/W	1	1 – Unlocked 2 – Locked	
35	UPDATE_EVT	Unacknowledged	1	D	R/W	0		
		Update State	1	D	R	0		
		Time Stamp	8	D	R	0		
		Static Revision	2	D	R	0		
		Relative Index	2	D	R	0		
36	BLOCK_ALM	Unacknowledged	1	D	R/W			
		Alarm State	1	D	R			
		Time Stamp	8	D	R			
		Sub-code	2	D	R			
		Value	1	D	R			
37	ALARM_SUM	Current	2	D	R			
		Unacknowledged	2	D	R			
		Unreported	2	D	R			
		Disabled	2	S	R/W	0		
38	ACK_OPTION	Automatic Acknowledge Option	2	S	R/W	0	0 – Disable 1 – Enable	
39	WRITE_PRI	Write Priority	1	S	R/W	0	0 to 15	
40	WRITE_ALM	Unacknowledged	1	D	R/W			
		Alarm State	1	D	R			
		Time Stamp	8	D	R			
		Sub-code	2	D	R			
		Value	1	D	R			
41	ITK_VER	ITK_version	2	S	R	4		

The Transducer Block contains block parameters that configure the device's functionality. It insulates the sensor characteristics and signal conditioning from the other device Function Blocks. Specifically, it interprets the sensor signal based on configured values, applies factory and process calibration data, compensates for temperature and process effects, and converts the resulting values in the configured Engineering Units that can be used by the Analog Input Blocks contained within the device.

The following diagram illustrates the Transducer Block design. The following table lists the Transducer Block parameter information.

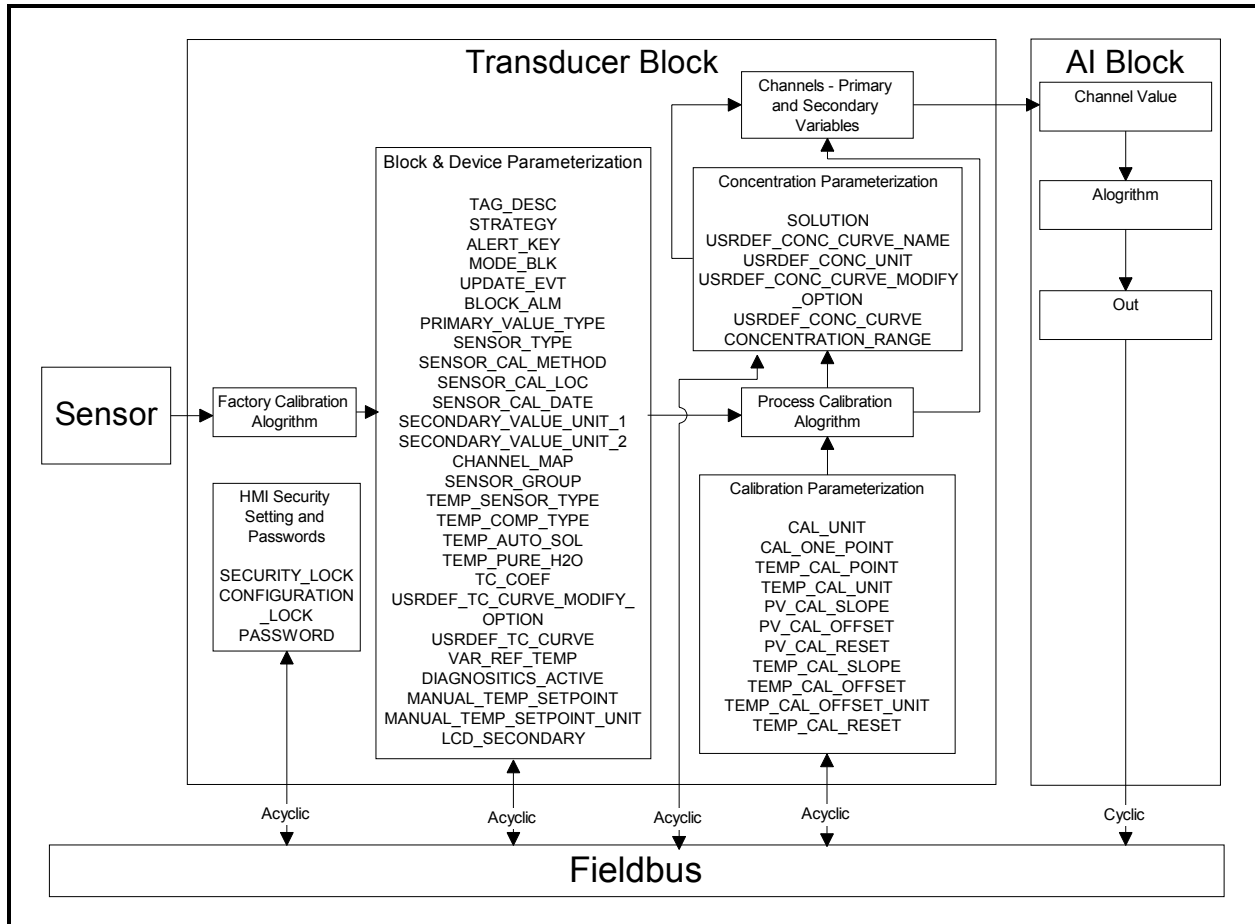

Figure 31 – Transducer Block Design Diagram

## CONDUCTIVITY/CONCENTRATION TRANSDUCER BLOCK

IDX	Name	Description	Bytes	ST	AR	Default	Valid Range	Note
0	BLOCK_OBJ	Block Object	62					
1	ST_REV	Static Revision	2	S	R	0		
2	TAG_DESC	TAG Description	32	S	R/W	Spaces		
3	STRATEGY	Strategy	2	S	R/W	0		
4	ALERT_KEY	Alert Key	1	S	R/W	0	1 to 255	
5	MODE_BLK	Target	1	N	R/W	OOS	Auto, OOS	
		Actual	1	D	R			
		Permitted	1	S	R/W	Auto, OOS	Auto, OOS	
		Normal	1	S	R/W	Auto	Auto, OOS	
6	BLOCK_ERR	Block error	2	D	R		0 – Off 1 – On	
7	UPDATE_EVT	Unacknowledged	1	D	R/W	0		
		Update State	1	D	R	0		
		Time Stamp	8	D	R	0		
		Static Rev	2	D	R	0		
		Relative Index	2	D	R	0		
8	BLOCK_ALM	Unacknowledged	1	D	R/W	0		
		Alarm State	1	D	R	0		
		Time Stamp	8	D	R	0		
		Sub-code	2	D	R	0		
		Value	1	D	R	0		
9	TRANSDUCER_DIRECTORY	Number of Transducer Directories & Start Indexes	4	N	R			
10	TRANSDUCER_TYPE		2	N	R	65535	65535 (Other)	
11	XD_ERROR	Transducer Error	1	D	R	0		
12	COLLECTION_DIRECTORY		28	N	R			
13	PRIMARY_VALUE_TYPE		2	S	R/W	113	113– Conductivity 117– Concentration	Note A
14	PRIMARY_VALUE	Value	4	D	R			Note B
		Status	1	D	R			
15	PRIMARY_VALUE_RANGE	High Range	4	N	R	1999000 $\mu$ S/cm	Table 3	Note C
		Low Range	4	N	R	0 $\mu$ S/cm	Table 3	
		Unit Index	2	N	R	1586 ( $\mu$ S/cm)	Table 2	
		Decimal point	1	N	R	2		
16	CAL_UNIT	Calibration Unit	2	S	R/W	1586 ( $\mu$ S/cm)	Table 2	
17	CAL_ONE_POINT	One-point Calibration Value	4	S	R/W	0 $\mu$ S/cm	Table 3	
18	SENSOR_TYPE		2	S	R/W	104	104 (ohms)	
19	SENSOR_RANGE	High Range	4	N	R	1999000 $\mu$ S/cm	Table 3	
		Low Range	4	N	R	0 $\mu$ S/cm	Table 3	
		Unit Index	2	N	R	1586 ( $\mu$ S/cm)	Table 2	
		Decimal point	1	N	R	2		

## CONDUCTIVITY/CONCENTRATION TRANSDUCER BLOCK (cont'd)

IDX	Name	Description	Bytes	ST	AR	Default	Valid Range	Note
20	SENSOR_SN	Serial Number	32	N	R	All blanks		
21	SENSOR_CAL_METHOD	Calibration Method	1	S	R/W	104	104 (user trim standard cal)	
22	SENSOR_CAL_LOC	Calibration Location	32	S	R/W	All blanks		
23	SENSOR_CAL_DATE	Calibration Date	7	S	R/W	All blanks		
24	SENSOR_CAL_WHO	Personnel Name	32	S	R/W	All blanks		
25	SECONDARY_VALUE_1	Sensor Temperature Value	4	D	R			
		Status	1	D	R			
26	SECONDARY_VALUE_UNIT_1		2	S	R/W	1001 (°C)	Table 4	
<b>MANUFACTURER SPECIFIC PARAMETERS</b>								
27	SECONDARY_VALUE_2	Concentration or Conductivity	4	D	R			
		Status	1	D	R			
28	SECONDARY_VALUE_UNIT_2		2	S	R/W	1342 (%)	Table 7	
29	CHANNEL_MAP		3	S	R/W			
30	SENSOR_GROUP	Sensor Group	1	S	R/W	0 (Group A)	0 – Group A 1 – Group B 2 – Group C	
31	SOLUTION	Solution Type	1	S	R/W	4 (User Defined)	0 – 0 to 15% NaOH 1 – 0 to 20% NaCl 2 – 0 to 18% HCl 3 – 0 to 20% H <sub>2</sub> SO <sub>4</sub> 4 – User Defined	Note D
32	TEMP_SENSOR_TYPE	Temperature Sensor Type	1	S	R/W	0 (3K Balco)	0 – 3K Balco 1 – PT100 2 – 4.75K RTD 3 – None	
33	TEMP_COMP_TYPE	Temperature Compensation Type	1	S	R/W	0 (Manual)	0 – Manual 1 – Automatic	
34	TEMP_AUTO_SOL	Auto Temperature Compensation Solute	1	S	R/W	0 (Standard KCl)	0 – Standard KCl 1 – TC Coefficient 2 – NaOH 3 – NaCl 4 – HCl 5 – H <sub>2</sub> SO <sub>4</sub> 6 – Pure H <sub>2</sub> O 7 – User Defined	Note E
35	TEMP_PURE_H2O	Pure H <sub>2</sub> O Temperature Compensation Option	1	S	R/W	0 (Neutral)	0 – Neutral 1 – Acid 2 – Base	Note F
36	TC_COEF	Temperature Compensation Coefficient	4	S	R/W	2.0	0 to 9.99	Note G

## CONDUCTIVITY/CONCENTRATION TRANSDUCER BLOCK (cont'd)

IDX	Name	Description	Bytes	ST	AR	Default	Valid Range	Note
37	USRDEF_TC_CURVE_MODIFY_OPTION	User Defined Temperature Compensation Modify Option	1	S	R/W	0 (Modify individual entry)	0 – Individual Entry 1- Entire Table	Note H
38	USRDEF_TC_CURVE	User Defined Temperature Compensation Curve	48	S	R/W	<u>X, Y</u> 0, 1.8 25, 1.00 50, 0.69 75, 0.50 100, 0.38 156, 0.25	Each x value: 0 to 999 °C (Increasing monotonically)  Each y value: 0 to 19.99	Note H
39	VAR_REF_TEMP	Variable Reference Temperature	4	S	R/W	25.0°C	-20 to 200°C	
40	USRDEF_CONC_CURVE_NAME	User Defined Concentration Curve Name	6	S	R/W	AAAAAA	Characters A to Z, 0 to 9, space or “-“	Note I
41	USRDEF_CONC_UNIT	User Defined Concentration Curve Unit	2	S	R/W	1342 (%)	Table 2 (Concentration Units)	Note I
42	USRDEF_CONC_CURVE_MODIFY_OPTION	User Defined Concentration Curve Modify Option	1	S	R/W	0 (Modify individual entry)	0 – Individual Entry 1 – Entire Table	Note I
43	USRDEF_CONC_CURVE	User Defined Concentration Curve	48	S	R/W	<u>X, Y</u> 0, 0.0 40000, 4.0 80000, 8.0 120000, 12.0 160000, 16.0 199900, 19.99  x values shown in µS/cm  y values shown in %	Each x value: 0 to 1999000 µS/cm (Increasing monotonically)  Each y value: 0 to 1999% (conc. range 0) 0 to 199.9% (conc. range 1) 0 to 19.99% (conc. range 2) 0 to 1.999% (conc. range 3)  (y values monotonic)	Note I
44	CONCENTRATION_RANGE	Concentration Range	1	S	R/W	2 (0 to 19.99%)	0 – 0 to 1999 1 – 0 to 199.9 2 – 0 to 19.99 3 – 0 to 1.999	Note I
45	DIAGNOSTICS_ACTIVE	Sensor Diagnostics Activation	1	S	R/W	0 (OFF)	0 – OFF 1 – ON	
46	MANUAL_TEMP_SETPOINT	Temperature Value for Manual Temperature Compensation	4	S	R/W	25 °C	-20 to 300 °C	Note J
47	MANUAL_TEMP_SETPOINT_UNIT	Manual Temperature Setpoint Units	2	S	R/W	1001 (°C)	Table 4	
48	TEMP_CAL_POINT	Temperature Calibration Value	4	S	R/W	25 °C	-20 to 300 °C	Note J

## CONDUCTIVITY/CONCENTRATION TRANSDUCER BLOCK (cont'd)

IDX	Name	Description	Bytes	ST	AR	Default	Valid Range	Note
49	TEMP_CAL_UNIT	Temperature Calibration Value Units	2	S	R/W	1001 (°C)	Table 4	
50	PV_CAL_SLOPE	PV Calibration Slope	4	S	R/W	100%	20 to 500 %	
51	PV_CAL_SLOPE_UNIT	PV Calibration Slope Unit	2	N	R	1342 (%)	1342 (%)	
52	PV_CAL_OFFSET	PV Calibration Offset	4	S	R/W	0 $\mu$ S/cm	-20 to +20 $\mu$ S/cm (Sensor Group A) -4 to +4 $\mu$ S/cm (Sensor Group B) -0.8 to +0.8 $\mu$ S/cm (Sensor Group C)	
53	PV_CAL_OFFSET_UNIT	PV Calibration Offset Unit	2	N	R	1586 ( $\mu$ S/cm)	Table 2	
54	PV_CAL_RESET	Reset PV Calibration	1	S	R/W	0 (OFF)	0 – OFF 1 – ON	
55	TEMP_CAL_SLOPE	Temperature Calibration Slope	4	S	R/W	100%	20 to 150 %	
56	TEMP_CAL_SLOPE_UNIT	Temperature Calibration Slope Unit	2	N	R	1342 (%)		
57	TEMP_CAL_OFFSET	Temperature Calibration Offset	4	S	R/W	0 °C	-40 to +40 °C (3K Balco, PT100) -100 to +100 °C (4.75K RTD)	
58	TEMP_CAL_OFFSET_UNIT	Temperature Calibration Offset Unit	2	S	R/W	1001 (°C)	Table 4	
59	TEMP_CAL_RESET	Reset Temperature Calibration	1	S	R/W	0 (OFF)	0 – OFF 1 – ON	
60	LCD_SECONDARY	LCD Secondary Display Option	1	S	R/W	0 (Temperature in °C)	Table 5	
61	SECURITY_LOCK	Security Menu Password-enable for Keypad Operation	1	S	R/W	0 (DISABLE)	0 – Disable 1- Enable	
62	CONFIGURATION_LOCK	Configuration Menu Password-enable for Keypad Operation	1	S	R/W	0 (DISABLE)	0 – Disable 1 - Enable	
63	CALIBRATION_LOCK	Calibration Menu Password-enable for Keypad Operation	1	S	R/W	0 (DISABLE)	0 – Disable 1- Enable	
64	SECURITY_PASSWORD	3-digit Password for Password-enabled Keypad Operations	3	S	R/W	000	000 to 999	
65	EXTENDED_STATUS	Extended Status	9	D	R			

The Analog Input Function Block can be mapped to one out of the five outputs channels from the Transducer Block and makes this information available to other function blocks on the fieldbus network. The CHANNEL parameter selects the input from the Transducer Block. Available channels include the primary process variable (Conductivity when the PRIMARY\_VALUE\_TYPE is set to Conductivity or Concentration when the PRIMARY\_VALUE\_TYPE is set to Concentration), temperature, and secondary process variable (Concentration when the PRIMARY\_VALUE\_TYPE is set to Conductivity or Conductivity when the PRIMARY\_VALUE\_TYPE is set to Concentration).

The following diagram illustrates the Analog Input Function Block design. The following table lists the Analog Input Function Block parameter information.

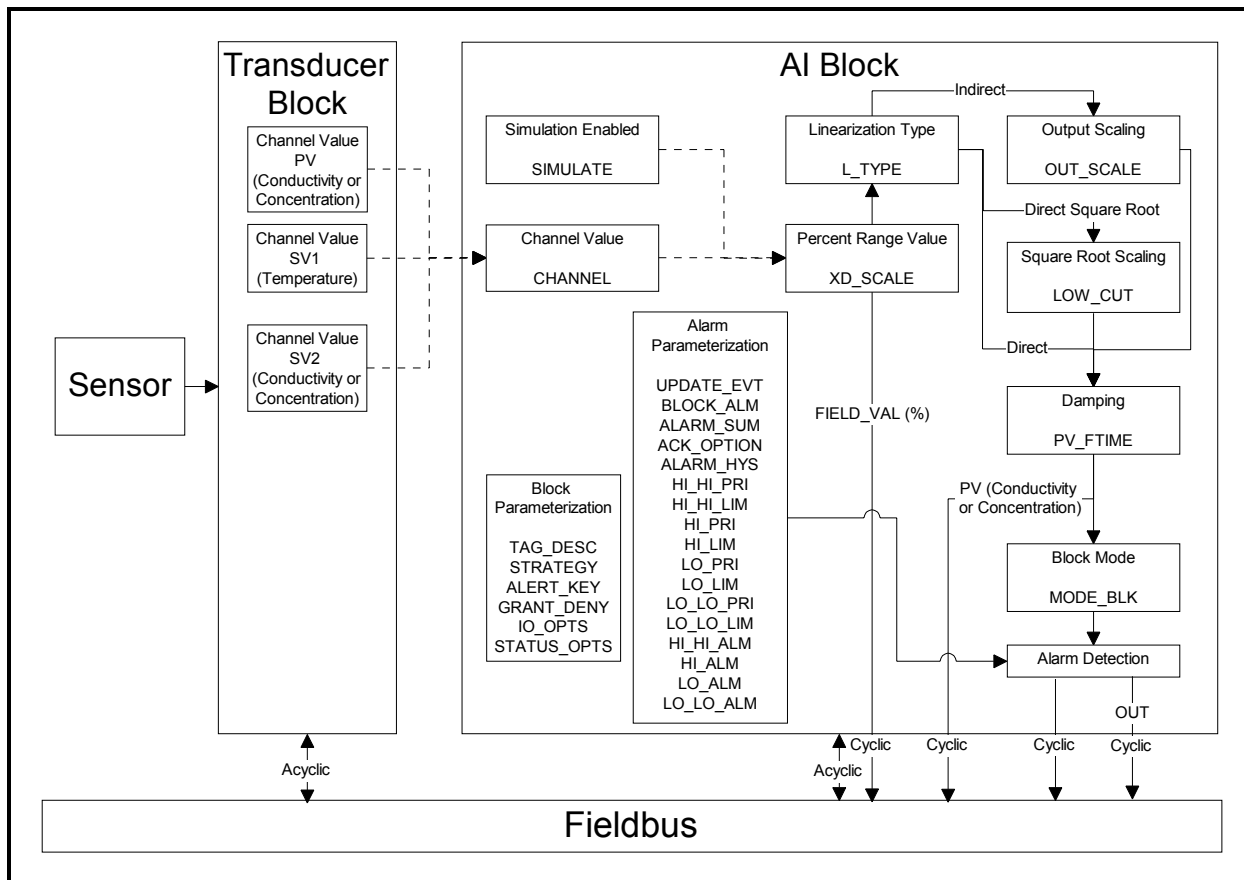

Figure 32 – Analog Input Function Block Design Diagram

## ANALOG INPUT 1 - FUNCTION BLOCK

IDX	Name	Description	Bytes	ST	AR	Default	Valid Range	Note
0	BLOCK_OBJ	Block Object	62					
1	ST_REV	Static Revision	2	S	R	0		
2	TAG_DESC	TAG Description	32	S	R/W	Spaces		
3	STRATEGY	Strategy	2	S	R/W	0		
4	ALERT_KEY	Alert Key	1	S	R/W	0	1 to 255	
5	MODE_BLK	Target	1	N	R/W	OOS	OOS, Auto, Man	
		Actual	1	D	R	-		
		Permitted	1	S	R/W	OOS, Auto, Man		
		Normal	1	S	R/W	Auto	OOS, Auto, Man	
6	BLOCK_ERR	Block error	2	D	R		0 – Off 1 – On	
7	PV	Process value	4	D	R	-		
		Status	1	D	R	-		
8	OUT	Measured Value	4	N	R	-		Note K
		Status	1	D	R	-		
9	SIMULATE	Simulate Status	1	D	R/W	0		
		Simulate Value	4	D	R/W	0		
		Transducer Status	1	D	R	0		
		Transducer Value	4	D	R	0		
		Simulate Enable/Disable	1	N	R/W	1	1 – Disabled 2 – Enabled	
10	XD_SCALE	High Range	4	S	R/W	1999000 $\mu$ S/cm		Note L
		Low Range	4	S	R/W	0 $\mu$ S/cm		
		Unit Index	2	S	R/W	$\mu$ S/cm	Table 7	
		Decimal point	1	S	R/W	2		
11	OUT_SCALE	High Range	4	S	R/W	1999000 $\mu$ S/cm		Note L
		Low Range	4	S	R/W	0 $\mu$ S/cm		
		Unit Index	2	S	R/W	$\mu$ S/cm	Table 7	
		Decimal point	1	S	R/W	2		
12	GRANT_DENY	Grant	1	D	R/W	0		
		Deny	1	D	R/W	0		
13	IO_OPTS	Input / Output block options	2	S	R/W	0	Low cutoff 0 – Disable 1024 – Enable	
14	STATUS_OPTS	Status Options	2	S	R/W	64	8, 64, 128, 256	
15	CHANNEL	Channel	2	S	R/W	1	1 to 3 (or as determined by Transducer Block CHANNEL_MAP)	
16	L_TYPE	Linearization Type	1	S	R/W	1	1 to 3 Table 6	
17	LOW_CUT	Low Cut Off	4	S	R/W		Positive	
18	PV_FTIME	Filter Time	4	S	R/W	0 sec	Positive	
19	FIELD_VAL	Percent Value	4	D	R	-		
		Status	1	D	R	-		
20	UPDATE_EVT	Unacknowledged	1	D	R/W	0		
		Update State	1	D	R	0		
		Time Stamp	8	D	R	0		
		Static Revision	2	D	R	0		
		Relative Index	2	D	R	0		

## ANALOG INPUT 1 - FUNCTION BLOCK (cont'd)

IDX	Name	Description	Bytes	ST	AR	Default	Valid Range	Note
21	BLOCK_ALM	Unacknowledged	1	D	R/W	0		
		Alarm State	1	D	R	0		
		Time Stamp	8	D	R	0		
		Sub-code	2	D	R	0		
		Value	1	D	R	0		
22	ALARM_SUM	Current	2	D	R	0		
		Unacknowledged	2	D	R	0		
		Unreported	2	D	R	0		
		Disabled	2	S	R/W	0		
23	ACK_OPTION	Automatic Acknowledge Option	2	S	R/W	0	0 – Disable 1 – Enable	
24	ALARM_HYS	Alarm Hysteresis	4	S	R/W	0.5%	0 to 50 %	
25	HI_HI_PRI	High-High Priority	1	S	R/W	0	0 to 15	
26	HI_HI_LIM	High-High Limit	4	S	R/W	1999000 $\mu$ S/cm		Note M
27	HI_PRI	High Priority	1	S	R/W	0	0 to 15	
28	HI_LIM	High Limit	4	S	R/W	1999000 $\mu$ S/cm		Note M
29	LO_PRI	Low Priority	1	S	R/W	0	0 to 15	
30	LO_LIM	Low Limit	4	S	R/W	0 $\mu$ S/cm		Note M
31	LO_LO_PRI	Low-Low Priority	1	S	R/W	0	0 to 15	
32	LO_LO_LIM	Low-Low Limit	4	S	R/W	0 $\mu$ S/cm		Note M
33	HI_HI_ALM	Unacknowledged	1	D	R/W	0		
		Alarm State	1	D	R	0		
		Time Stamp	8	D	R	0		
		Sub-code	2	D	R	0		
		Value	4	D	R	0		
34	HI_ALM	Unacknowledged	1	D	R/W	0		
		Alarm State	1	D	R	0		
		Time Stamp	8	D	R	0		
		Sub-code	2	D	R	0		
		Value	4	D	R	0		
35	LO_ALM	Unacknowledged	1	D	R/W	0		
		Alarm State	1	D	R	0		
		Time Stamp	8	D	R	0		
		Sub-code	2	D	R	0		
		Value	4	D	R	0		
36	LO_LO_ALM	Unacknowledged	1	D	R/W	0		
		Alarm State	1	D	R	0		
		Time Stamp	8	D	R	0		
		Sub-code	2	D	R	0		
		Value	4	D	R	0		

## ANALOG INPUT 2 - FUNCTION BLOCK

IDX	Name	Description	Bytes	ST	AR	Default	Valid Range	Note
0	BLOCK_OBJ		62					
1	ST_REV	Static Revision	2	S	R	0		
2	TAG_DESC	TAG Description	32	S	R/W	Spaces		
3	STRATEGY	Strategy	2	S	R/W	0		
4	ALERT_KEY	Alert Key	1	S	R/W	0	1 to 255	
5	MODE_BLK	Target	1	N	R/W	OOS	OOS, Auto, Man	
		Actual	1	D	R	-		
		Permitted	1	S	R/W	OOS, Auto, Man		
		Normal	1	S	R/W	Auto	OOS, Auto, Man	
6	BLOCK_ERR	Block error	2	D	R		0 – Off 1 – On	
7	PV	Process value	4	D	R	-		
		Status	1	D	R	-		
8	OUT	Measured Value	4	N	R	-		Note K
		Status	1	D	R	-		
9	SIMULATE	Simulate Status	1	D	R/W	0		
		Simulate Value	4	D	R/W	0		
		Transducer Status	1	D	R	0		
		Transducer Value	4	D	R	0		
		Simulate Enable/Disable	1	N	R/W	1	1 – Disable 2 – Enable	
10	XD_SCALE	High Range	4	S	R/W	300 °C		Note L
		Low Range	4	S	R/W	-20 °C		
		Unit Index	2	S	R/W	°C	Table 7	
		Decimal point	1	S	R/W	2		
11	OUT_SCALE	High Range	4	S	R/W	300 °C		Note L
		Low Range	4	S	R/W	-20 °C		
		Unit Index	2	S	R/W	°C	Table 7	
		Decimal point	1	S	R/W	2		
12	GRANT_DENY	Grant	1	D	R/W	0		
		Deny	1	D	R/W	0		
13	IO_OPTS	Input / Output Block Options	2	S	R/W	0	Low Cut-off 0 – Disable 1024 – Enable	
14	STATUS_OPTS	Status Options	2	S	R/W	64	8, 64, 128, 256.	
15	CHANNEL	Channel	2	S	R/W	2	1 to 3 (or as determined by Transducer Block CHANNEL_MAP)	
16	L_TYPE	Linearization Type	1	S	R/W	1	1 to 3 Table 6	
17	LOW_CUT	Low Cut Off	4	S	R/W		Positive	
18	PV_FTIME	Filter Time	4	S	R/W	0 sec	Positive	
19	FIELD_VAL	Percent Value	4	D	R	-		
		Status	1	D	R	-		
20	UPDATE_EVT	Unacknowledged	1	D	R/W	0		
		Update State	1	D	R	0		
		Time Stamp	8	D	R	0		
		Static Revision	2	D	R	0		
		Relative Index	2	D	R	0		

## ANALOG INPUT 2 - FUNCTION BLOCK (cont'd)

IDX	Name	Description	Bytes	ST	AR	Default	Valid Range	Note
21	BLOCK_ALM	Unacknowledged	1	D	R/W	0		
		Alarm State	1	D	R	0		
		Time Stamp	8	D	R	0		
		Sub-code	2	D	R	0		
		Value	1	D	R	0		
22	ALARM_SUM	Current	2	D	R	0		
		Unacknowledged	2	D	R	0		
		Unreported	2	D	R	0		
		Disabled	2	S	R/W	0		
23	ACK_OPTION	Automatic Acknowledge Option	2	S	R/W	0	0 – Disable 1 – Enable	
24	ALARM_HYS	Alarm Hysteresis	4	S	R/W	0.5%	0 to 50 %	
25	HI_HI_PRI	High-High Priority	1	S	R/W	0	0 to 15	
26	HI_HI_LIM	High-High Limit	4	S	R/W	300 °C		Note M
27	HI_PRI	High Priority	1	S	R/W	0	0 to 15	
28	HI_LIM	High Limit	4	S	R/W	300 °C		Note M
29	LO_PRI	Low Priority	1	S	R/W	0	0 to 15	
30	LO_LIM	Low Limit	4	S	R/W	-20 °C		Note M
31	LO_LO_PRI	Low-Low Priority	1	S	R/W	0	0 to 15	
32	LO_LO_LIM	Low-Low Limit	4	S	R/W	-20 °C		Note M
33	HI_HI_ALM	Unacknowledged	1	D	R/W	0		
		Alarm State	1	D	R	0		
		Time Stamp	8	D	R	0		
		Sub-code	2	D	R	0		
		Value	4	D	R	0		
34	HI_ALM	Unacknowledged	1	D	R/W	0		
		Alarm State	1	D	R	0		
		Time Stamp	8	D	R	0		
		Sub-code	2	D	R	0		
		Value	4	D	R	0		
35	LO_ALM	Unacknowledged	1	D	R/W	0		
		Alarm State	1	D	R	0		
		Time Stamp	8	D	R	0		
		Sub-code	2	D	R	0		
		Value	4	D	R	0		
36	LO_LO_ALM	Unacknowledged	1	D	R/W	0		
		Alarm State	1	D	R	0		
		Time Stamp	8	D	R	0		
		Sub-code	2	D	R	0		
		Value	4	D	R	0		



### Note.

- A) PRIMARY\_VALUE\_TYPE parameter establishes the type of measurement the device is performing. The default measurement type is Conductivity. When writing to this parameter (i.e., switching the device measurement type to Concentration), the device should be kept in OOS mode until all the necessary TB and AI variables are properly configured.
- B) PRIMARY\_VALUE is the output from the TB and the default input for AI1. This value is used by the XD\_SCALE parameter. Both parameters carry the same Engineering Unit (as shown in the PRIMARY\_VALUE\_RANGE Unit Index).
- C) PRIMARY\_VALUE\_RANGE parameter is read only in the TB. The PRIMARY\_VALUE\_RANGE is not changed when the XD\_SCALE of an AI that is mapped to the PV channel is modified. The PRIMARY\_VALUE\_RANGE unit is changed when the XD\_SCALE unit of an AI that is mapped to the PV channel is modified.
- D) The SOLUTION selections are restricted by the SENSOR\_GROUP that is configured. For Group A, all selections are available. For Groups B and C, only User Defined is available.
- E) TEMP\_AUTO\_SOL selections are restricted by the SENSOR\_GROUP that is configured. For Group A, all selections except for Pure H2O are available. For Group B, Standard KCl, TC Coefficient and User Defined are available. For Group C, Standard KCl, TC Coefficient, Pure H2O and User Defined are available.
- F) TEMP\_PURE\_H2O selections are only available when TEMP\_COMP\_TYPE is set to Auto and Pure H2O is selected for TEMP\_AUTO\_SOL.
- G) TC\_COEF parameter is only valid when TEMP\_COMP\_TYPE is set to Auto and TC Coefficient is selected for TEMP\_AUTO\_SOL.
- H) USRDEF\_TC\_CURVE parameters are only valid when TEMP\_COMP\_TYPE is set to Auto and User Defined is selected for TEMP\_AUTO\_SOL. Default values are in degrees Celsius and conductivity ratios.
- I) USRDEF\_CONC and CONCENTRATION\_RANGE parameters are only valid when SOLUTION is set to User Defined. Default values are in  $\mu\text{S}/\text{cm}$  and percent concentration.
- J) MANUAL\_TEMP\_SETPOINT or TEMP\_CAL\_POINT parameters are to set the temperature value for Manual Temperature Compensation (i.e., when TEMP\_COMP\_TYPE is set to MANUAL).
- K) AI OUT variable can only be written when the AI is set to the Manual Mode.
- L) AI XD\_SCALE and OUT\_SCALE parameters:
  - 1) When the AI channel is set to the PRIMARY\_VALUE, the XD\_SCALE and OUT\_SCALE parameters of the AI use the values established by the PRIMARY\_VALUE\_RANGE. Therefore, the XD\_SCALE and OUT\_SCALE parameters are dependent on the selection for the PRIMARY\_VALUE\_TYPE.
  - 2) When the AI channel is set to the SECONDARY\_VALUE\_1 (Temperature), the XD\_SCALE and OUT\_SCALE parameters of the AI are set to the default measurement temperature limits of  $-20$  to  $300^{\circ}\text{C}$  ( $-4$  to  $572^{\circ}\text{F}$ ).
  - 3) When the AI channel is set to the SECONDARY\_VALUE\_2, the XD\_SCALE and OUT\_SCALE parameters are dependent on the PRIMARY\_VALUE\_TYPE in the TB (Concentration when PRIMARY\_VALUE\_TYPE = Conductivity or Conductivity when PRIMARY\_VALUE\_TYPE = Concentration).
- M) HI\_HI\_LIM, HI\_LIM, LO\_LO\_LIM, and LO\_LIM parameters:
  - 1) When the AI channel is set to the PRIMARY\_VALUE, the limits are set to the default limits of the Conductivity sensor.
  - 2) When the AI channel is set to the SECONDARY\_VALUE\_1 (Temperature), the limits are set to the default measurement temperature limits of  $-20$  to  $300^{\circ}\text{C}$  ( $-4$  to  $572^{\circ}\text{F}$ ).
  - 3) When the AI channel is set to the SECONDARY\_VALUE\_2, the limits are set to the default limits determined by the Conductivity sensor range.

**TABLE 1**  
**PRIMARY\_VALUE\_TYPE Codes**

113	Conductivity
117	Concentration

**TABLE 2**  
**Engineering unit codes related to PRIMARY\_VALUE\_TYPE**

1302	mS/cm for PRIMARY_VALUE_TYPE = 113 (Conductivity)
1586	μS/cm for PRIMARY_VALUE_TYPE = 113 (Conductivity)
1342	% for PRIMARY_VALUE_TYPE = 117 (Concentration)
1423	ppm for PRIMARY_VALUE_TYPE = 117 (Concentration)
1424	ppb for PRIMARY_VALUE_TYPE = 117 (Concentration)
1588	no units for PRIMARY_VALUE_TYPE = 117 (Concentration)

**TABLE 3**  
**Valid ranges for PRIMARY\_VALUE\_TYPE**

PRIMARY\_VALUE\_TYPE 113:  
0 to 1999000 μS/cm (Sensor Group A)  
0 to 1999 μS/cm (Sensor Group B)  
0 to 199.9 μS/cm (Sensor Group C)

PRIMARY\_VALUE\_TYPE 117:  
For SOLUTION = Pre-defined:  
0 to 15% NaOH Solution  
0 to 20% NaCl Solution  
0 to 18% HCl Solution  
0 to 20% H2SO4 Solution

For SOLUTION = User Defined:  
0 to 1999% (Concentration Range 0)  
0 to 199.9% (Concentration Range 1)  
0 to 19.99% (Concentration Range 2)  
0 to 1.999% (Concentration Range 3)

**TABLE 4**  
**Temperature Unit Codes**

1001	Degrees Celsius
1002	Degrees Fahrenheit

**TABLE 5**  
**LCD Secondary display options**

0	Temperature in degree Celsius (Secondary variable 1)
1	Temperature in degree Fahrenheit (Secondary variable 1)
2	Sensor Type
3	Sensor Group
4	Conductivity (available when PRIMARY_VALUE_TYPE = Concentration)
5	Custom Concentration Display (available when PRIMARY_VALUE_TYPE = Concentration)
6	Software Revision

**TABLE 6**  
**LINEARIZATION\_TYPE Codes Table**

1	Direct
2	Indirect
3	Indirect Square root

**TABLE 7**  
**AIFB Engineering unit codes**

AI CHANNEL = PRIMARY\_VALUE (Channel 1)

1302	mS/cm for PRIMARY_VALUE_TYPE = 113 (Conductivity)
1586	μS/cm for PRIMARY_VALUE_TYPE = 113 (Conductivity)
1342	% for PRIMARY_VALUE_TYPE = 117 (Concentration)
1423	ppm for PRIMARY_VALUE_TYPE = 117 (Concentration)
1424	ppb for PRIMARY_VALUE_TYPE = 117 (Concentration)
1588	no units for PRIMARY_VALUE_TYPE = 117 (Concentration)

AI CHANNEL = Temperature (Channel 2; SECONDARY\_VALUE\_1)

1001	Degree Celsius
1002	Degree Fahrenheit

AI CHANNEL = Conductivity/Concentration (Channel 3; SECONDARY\_VALUE\_2)

1302	mS/cm when SECONDARY_VALUE_2 = Conductivity; PRIMARY_VALUE_TYPE = Concentration
1586	μS/cm when SECONDARY_VALUE_2 = Conductivity; PRIMARY_VALUE_TYPE = Concentration
1342	% when SECONDARY_VALUE_2 = Concentration; PRIMARY_VALUE_TYPE = Conductivity
1423	ppm when SECONDARY_VALUE_2 = Concentration; PRIMARY_VALUE_TYPE = Conductivity
1424	ppb when SECONDARY_VALUE_2 = Concentration; PRIMARY_VALUE_TYPE = Conductivity
1588	no units when SECONDARY_VALUE_2 = Concentration; PRIMARY_VALUE_TYPE = Conductivity

The following figure shows the possible connections that can be made between the Transducer Block outputs and the two AI's.

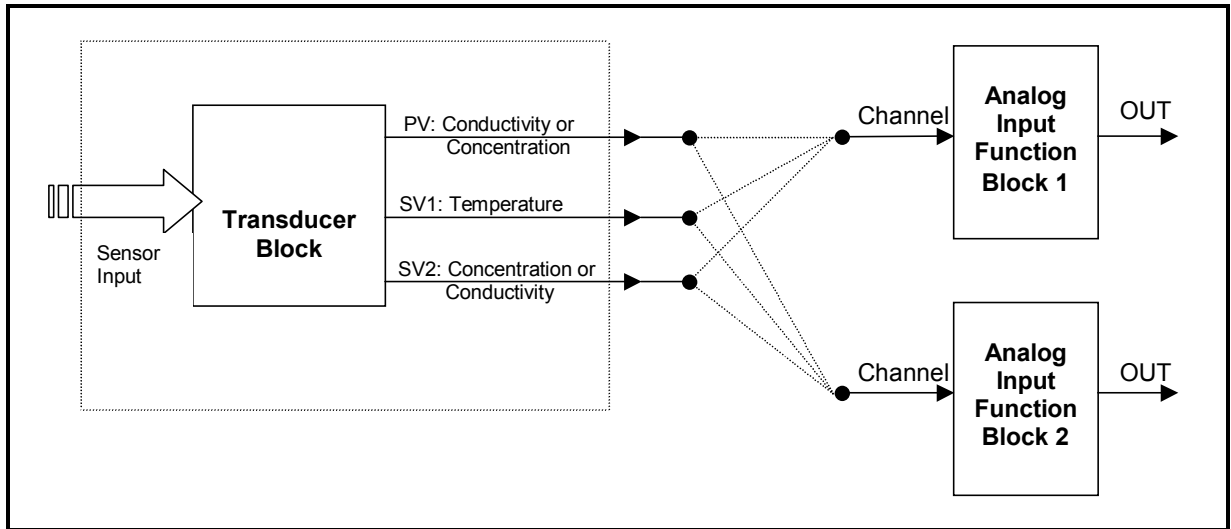

**Figure 33 - Possible Connections Between the TB and AI's**

The table below gives a summary of the relation between the selected measurement and available variables/channels that can be used as an input for the Analog Input Function Blocks.

	TYPE OF MEASURE (TB_PRIMARY_VALUE_TYPE)	
	Conductivity	Concentration
<b>Channel 1 (TB_PRIMARY_VALUE)</b>	Conductivity Value	Concentration Value
<b>Channel 2 (TB_SECONDARY_VALUE_1)</b>	Temperature	Temperature
<b>Channel 3 (TB_SECONDARY_VALUE_2)</b>	Concentration Value	Conductivity Value

## HARDWARE DIP SWITCH FUNCTIONS

There are four switches on the Microprocessor/Display PCB Assembly that perform unique transmitter functions. The figure below shows the location and function of these switches.

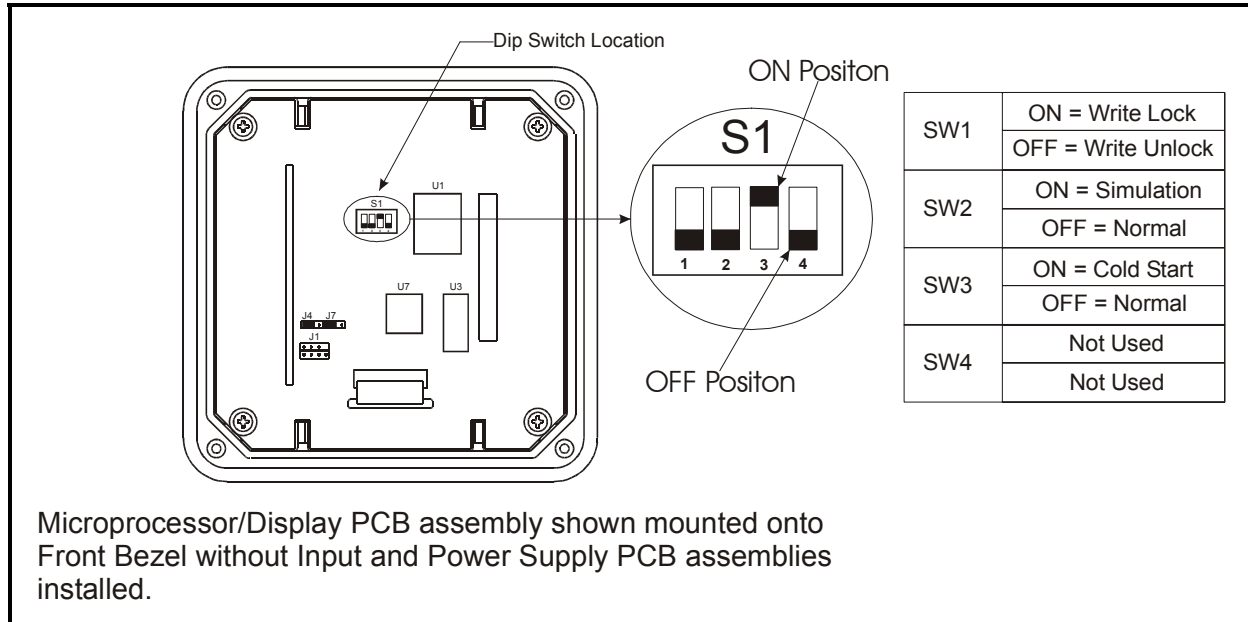

**Figure 34 – Hardware Dip Switch Location and Function**

Switch number 1 is the Write Lock. When this switch is in the ON position and the Hardware Write Lock is selected in the Resource Block FEATURE\_SEL, the transmitter prevents any modification of data or parameters that can be performed both locally and from a class 1 or 2 MASTER device.

Switch number 2 is used to set the transmitter into Simulation mode.

Switch number 3 is used for Cold Startup. When this switch is in the ON position before powering up the transmitter, most transmitter parameters are set to default values (See Device Blocks for default settings). These default parameters are found in both the Transducer and Analog Input Function Blocks.

Switch number 4 is not used and has been reserved for future use.

**\***

**Note.**

A Cold Startup will adjust several parameters to a defined default value. Cold Startup may be used to reset the initial operating condition of the transmitter. When the Cold Start switch is in the ON position on transmitter power up, critical transmitter parameters will be reset to default values. The SW3 switch must be in the OFF position to ensure user configured data is not overwritten on transmitter power up.

# SIMPLE FAULT FINDING

If the transmitter does not appear to be working satisfactory, carry out the following troubleshooting checks before contacting your nearest Service Center or Factory Representative.

If the instrument is to be returned for repair, ensure that it is adequately packed using the original polystyrene box or high-density chip foam. **The Return Materials Authorization (RMA) number must be sent with the instrument. Equipment returned to ABB Inc. with incorrect or incomplete information may result in significant delays or non-acceptance of the shipment.** At the time the RMA number is given, an estimate of the repair costs will be provided, and a customer purchase order will be requested. **The RMA and purchase order numbers must be clearly marked on all paperwork and on the outside of the return package container (i.e., packing box).**

Equipment needed:

FOUNDATION Fieldbus configuration software or communication Host/System

### High, Low or Irregular Process Variables

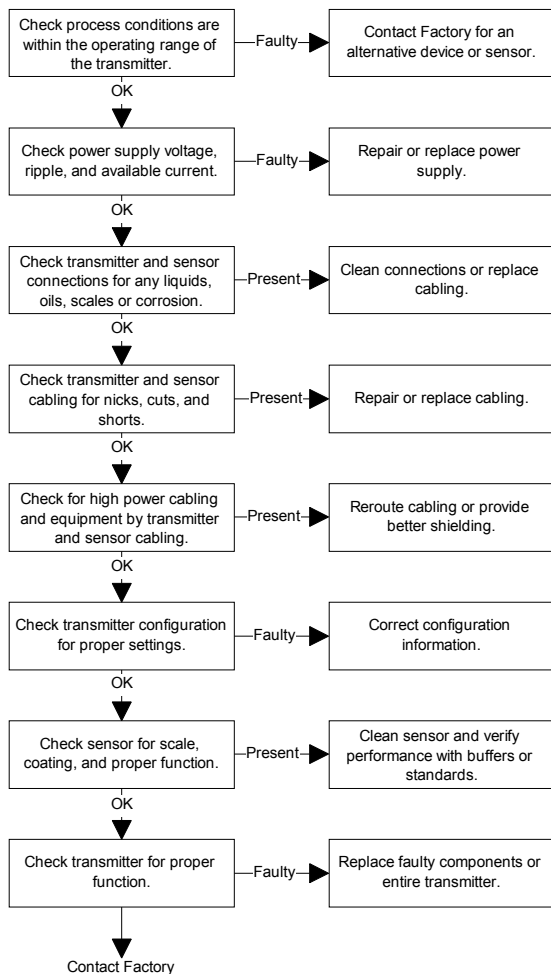

### No Output

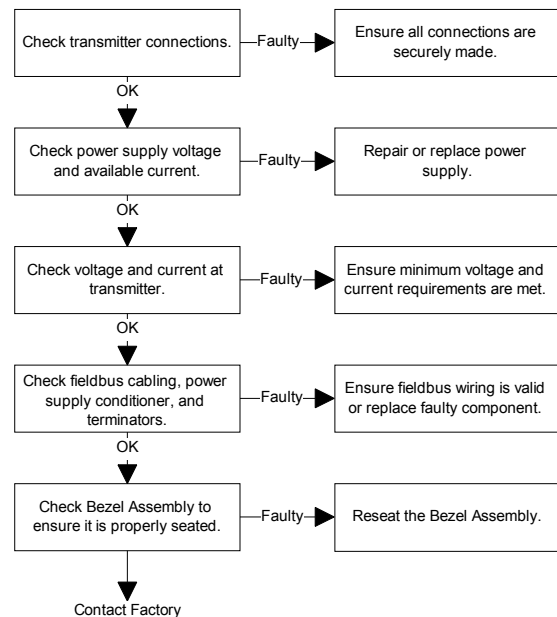

Since the transmitter has an integral display, diagnostic codes are shown in the secondary display region when interrogated using the FAULT Info key. In addition, the transmitter status is available through most configuration or system/host tools.

## DIAGNOSTIC INFORMATION

The TB82EC FF transmitter performs a number of diagnostic checks on hardware, software, and sensor functions. If a nonconforming condition is detected, the user is alerted to faults locally by a flashing FAULT indicating icon and remotely by a configuration and/or system/host tool.

When using the local HMI, diagnostic faults are interrogated using the FAULT Info key in the Measure Mode. A short text string and fault code is alternately shown in the secondary display region. If multiple faults exist, the FAULT Info key moves the user to the next fault. Once all faults have been interrogated, the transmitter returns to the Measure Mode. A flashing FAULT icon indicates a new fault condition that has not been interrogated. Conversely, a non-flashing FAULT icon indicates all fault conditions have been interrogated but not resolved. When all fault conditions are resolved, the FAULT icon and FAULT Info key are de-energized.

Fault conditions are grouped into two categories based on severity. Conditions that result in degradation of transmitter performance are reported as Problem Codes (PC), while conditions that render the transmitter inoperable are reported as Error Codes (EC). Fault codes are reported in the secondary display region in a first in, first out order (i.e., the first detected fault condition is the first condition that is displayed upon interrogation). The table below lists all applicable Error and Problem codes and the suggested Corrective Actions. See Text Prompt Definitions for fault code description.

Fault Code	Fault Text String	Corrective Action
EC1	PV.AD	Contact Factory.
EC3	PH.PCB	Incorrect Input PCB assembly has been detected. pH/ORP/pION Input PCB Assembly is being used with TB82EC product firmware.
EC4	TC.PCB	Incorrect Input PCB assembly has been detected. Toroidal Conductivity Input PCB Assembly is being used with TB82EC product firmware.
EC5	DO.PCB	Incorrect Input PCB assembly has been detected. Dissolved Oxygen Input PCB Assembly is being used with TB82EC product firmware.
EC6	TE.PCB	Incorrect Input PCB assembly has been detected. Two-Electrode Conductivity Input PCB Assembly is being used with TB82EC product firmware.
PC3	DRTY.SN	<ol style="list-style-type: none"> <li>1) Verify sensor wiring is properly connected.</li> <li>2) Verify sensor wiring is free of nicks, cuts, breaks and/or open connections.</li> <li>3) Verify sensor wiring is not shorted to other wiring or metal surfaces.</li> <li>4) Verify terminal blocks and other connections are free of any liquids, oils, scale or corrosion.</li> <li>5) If a sensor extension is being used, verify ABB approved cabling is used and the connections are dry and free of corrosion.</li> <li>6) Verify sensor tip is clean. Remove any foreign material. Clean sensor. Verify sensor responds to conductivity standard solutions. If sensor does not respond, electronically test sensor as described Sensor Electronic Test section.</li> <li>7) Verify configuration settings are correct..</li> </ol>
PC4	GND.LP	<ol style="list-style-type: none"> <li>1) Verify sensor wiring is properly connected.</li> <li>2) Verify sensor wiring is not shorted to other wiring or metal surfaces.</li> <li>3) Verify terminal blocks and other connections are free of any liquids, oils, scale or corrosion.</li> <li>4) If a sensor extension is being used, verify ABB approved cabling is used and the connections are dry and free of corrosion.</li> <li>5) Verify configuration settings are correct.</li> <li>6) Verify internal sensor connections are free of any liquids, oils, scale or corrosion.</li> </ol>
PC8	HI.PV	<ol style="list-style-type: none"> <li>1) Verify process conditions are within transmitter range values.</li> <li>2) Verify sensor wiring is properly connected.</li> <li>3) Verify sensor wiring is free of nicks, cuts, breaks and/or open connections.</li> <li>4) Verify configuration settings are correct.</li> <li>5) Verify manual or measured temperature value is correct. If a temperature sensor is not being used, verify that TMP.SNS is set to none in the transmitter configuration.</li> </ol>
PC9	LO.PV	See PC8 corrective actions.
PC10	HI.TEMP	See PC8 corrective actions.

Fault Code	Fault Text String	Corrective Action
PC11	LO.TEMP	See PC8 corrective actions.
PC12	TEMP.AD	See PC8 corrective actions. If all items check out properly, replace Input PCB Assembly. Transmitter can be used; however, the Temperature Compensation must be set to Manual and a Temperature Calibration should be conducted in order to set the Manual Temperature Value close to the operating conditions.
PC20	BAD.SEE	Contact Factory.
PC21	NO.F.CAL	
PC30	R0.F.CAL	
PC31	R1.F.CAL	
PC32	R2.F.CAL	
PC33	R3.F.CAL	
PC34	R4.F.CAL	
PC35	G0.F.CAL	
PC36	G1.F.CAL	
PC37	G2.F.CAL	
PC38	G3.F.CAL	
PC39	G4.F.CAL	
PC40	W0.F.CAL	
PC41	W1.F.CAL	
PC42	W2.F.CAL	
PC43	W3.F.CAL	
PC44	W4.F.CAL	
PC45	BA.F.CAL	
PC46	PT.F.CAL	
PC47	RT.F.CAL	
PC50	R0.CHKS	
PC51	R1.CHKS	
PC52	R2.CHKS	
PC53	R3.CHKS	
PC54	R4.CHKS	
PC55	G0.CHKS	
PC56	G1.CHKS	
PC57	G2.CHKS	
PC58	G3.CHKS	
PC59	G4.CHKS	
PC60	W0.CHKS	
PC61	W1.CHKS	
PC62	W2.CHKS	
PC63	W3.CHKS	
PC64	W4.CHKS	
PC65	BA.CHKS	
PC66	PT.CHKS	
PC67	RT.CHKS	
PC70	GL.AD	
PC72	DS.AD	

### **Calibration Diagnostic Messages**

The transmitter performs automatic efficiency and offset calculations relative to a theoretically perfect conductivity and/or temperature sensor during each calibration cycle. Calibration history is retained for future interrogation using the Edit Calibrate State. The calibration constants that are displayed are Slope and Offset for the Process Variable and Temperature.

A Slope of less than 0.2 or greater than 5 indicates a potentially bad process calibration point or poorly performing sensor. In these cases, the text string BAD.CAL (bad calibration) is displayed in the secondary display region. The user is returned to the beginning of the calibration cycle after the bad calibration has been reported.

An Offset value of less than -20  $\mu\text{S}/\text{cm}$  for Sensor Group A, -4  $\mu\text{S}/\text{cm}$  for Sensor Group B, and -0.800  $\mu\text{S}/\text{cm}$  or greater than 20  $\mu\text{S}/\text{cm}$  for Sensor Group A, 4  $\mu\text{S}/\text{cm}$  for Sensor Group B, and 0.800  $\mu\text{S}/\text{cm}$  for Sensor Group C also indicates a potentially bad process calibration or poorly performing sensor. Again, a bad calibration will be reported, and the user returned to the beginning of the calibration cycle.

For temperature, a bad calibration will be reported and calibration values will not be accepted for Slope values that are less than 0.2 or greater than 1.5 and Offset values that are less than -40°C or greater than +40°C. As with conductivity, temperature calibrations use smart software routines that automatically adjust the Slope, Offset, or Both values based on the calibration value being entered and calibration history if it exists.

---

## SENSOR TROUBLESHOOTING

---

If the sensor is suspected of being the source of problems, a quick visual inspection in many cases will identify the problem. If nothing can be seen, a few electrical tests using a digital multimeter can be performed to determine if the sensor is faulty. Some of these tests can be performed with the sensor either in or out of the process stream.

---

### Visual Sensor Inspection

---

Remove the sensor from the process and visually check the following:

#### Sensor body

Inspect the sensor body for cracks and distortions. If any are found, contact your local ABB representative for alternative sensor styles and materials.

#### Cable and connectors

Inspect the sensor cable for cracks, cuts, or shorts. If a junction box and/or extension cable are used, check for moisture, oil, corrosion, and/or particulates where connections are made. All connections must be dry, oil-free, corrosion-free, and particulate-free. Even slight amounts of moisture, corrosion, and particulates can short sensor signals and affect conductivity readings. Check to see that all wiring is dry and not shorting against any metal, conduit, or earth grounds.

#### O-ring seals

Inspect the sealing O-rings for attack by the process liquid. If the O-rings show evidence of corrosion, distortion, or deterioration, contact your local ABB representative for alternate material choices.

---

### Sensor Electronic Test

---

---

## Additional Diagnostic Messages

---

Other diagnostic messages may appear during transmitter programming. These messages include BAD.VAL (bad value) and DENIED.

BAD.VAL indicates the attempted numeric entry of a value that is out of the allowed transmitter range. See the Specification Section for transmitter range limits.

DENIED indicates incorrect entry of a security password. See the Security Mode section for more information.

Conductivity sensors can be electronically tested to verify the integrity of the sensor and cable. The sensor leads and automatic temperature compensator leads must be disconnected from the transmitter before any tests can be performed. Additionally, these tests require a Digital Multimeter (DMM) that has a conductance function capable of 0 to 200 nS and a resistance function capable of 0 to 20 kohms.

The temperature sensor can be tested with the sensor in the process and is tested using the following procedure:

1. Check the resistance of the Temperature Sensor by measuring the resistance between the yellow and blue Temperature Compensator leads.

For a 3 kohm Balco RTD, the expected resistance can be calculated using:

$$R_{TC} = (((T - 25) * 0.0045) + 1) * 3000$$

where T is in degrees Celsius. The measured resistance should be within the expected value by  $\pm 15\%$ .

For a Pt100 RTD, the expected resistance can be calculated using:

$$R_{TC} = 100 + (T * 0.385)$$

where T is in degrees Celsius. The measured resistance should be within the expected value by  $\pm 5\%$ .

For the 4.75 kohm Network, the expected resistance can be calculated using:

$$R_{TC} = 6329 - 104.5 * T + 0.774 T^2 - 0.0026 * T^3 + 3E-06 * T^4$$

where T is in degrees Celsius. The measured resistance should be within the expected value by ± 5%.

Moisture intrusion behind the sensor electrode seal can be detected with the sensor removed from the process. Thoroughly dry and tested the sensor using the following procedure:

1. Check the conductance between the yellow Temperature Sensor lead and each of the other sensor leads (i.e., green, red, white, black, and heavy green leads). The reading must be less than 0.05 nS.
2. Check the conductance between the green Drive lead and each of the other sensor leads (i.e., black, white, red, and heavy green leads). The reading must be less than 0.05 nS.
3. Check the conductance between the heavy green lead (Shield) and each of the other sensor leads (i.e., blue, yellow, black, green, red, and white leads). The reading must be less than 0.05 nS.

## Transmitter Electronic Test

The TB82EC FF Transmitter can be electronically tested without requiring the use of a sensor. To perform this type of test, use the following procedure:

- 1) Disconnect the sensor from the transmitter.
- 2) Set the transmitter temperature compensation (TC.TYPE) to MANUAL.
- 3) Connect the transmitter to a resistance decade box as shown in the figure below.

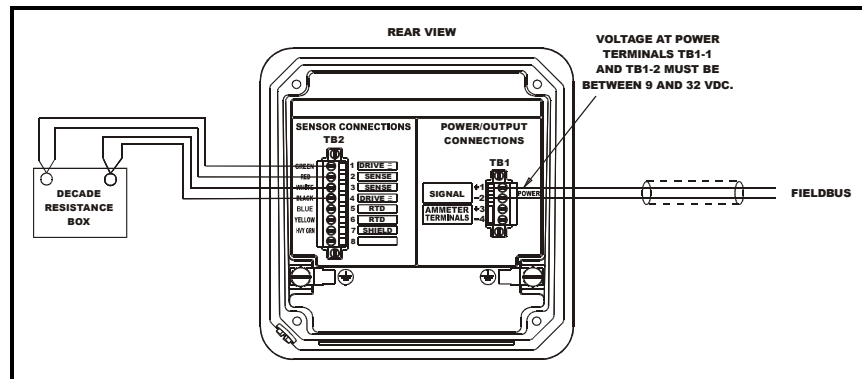

**Figure 35 – Sensor Simulation Setup**

- 4) Set the decade resistance box to the values indicated in the following table:

Sensor Group	Variable Resistance (ohm)	Desired Display Value	Actual Display Value
A	Open	0.0 μS/cm	
	5,000.0	100.0 μS/cm	
	1,000.0	500 μS/cm	
	500.0	1000 μS/cm	
	100.0	5.00 mS/cm	
	50.0	10.00 mS/cm	
	10.0	50.0 mS/cm	
	5.0	100.0 mS/cm	
	1.0	500 mS/cm	
B	0.5	1000 mS/cm	
	Open	0.00 μS/cm	
	50,000	1.00 μS/cm	
	5,000	10.00 μS/cm	
	1,000	50.0 μS/cm	

Sensor Group	Variable Resistance (ohm)	Desired Display Value	Actual Display Value
	500	100.0 $\mu$ S/cm	
	100	500 $\mu$ S/cm	
	50	1000 $\mu$ S/cm	

Sensor Group	Variable Resistance (ohm)	Desired Display Value	Actual Display Value
C	Open	0.000 $\mu$ S/cm	
	100,000	0.050 $\mu$ S/cm	
	50,000	0.100 $\mu$ S/cm	
	5,000	1.000 $\mu$ S/cm	
	1,000	5.00 $\mu$ S/cm	
	500	10.00 $\mu$ S/cm	
	100	50.0 $\mu$ S/cm	
	50	100.0 $\mu$ S/cm	

**\***

**Note.**

1. The transmitter calibration values must be set back to factory values in order for the sensor simulation procedure to be valid.
2. Lead wire and contact resistance becomes a significant part of simulated conductivity for simulated resistance values less than 10 ohms. Measure all resistances going to the transmitter to ensure accurate results.

## DIAGNOSTIC INFORMATION RECEIVED FROM THE FIELDBUS

Dynamic variables and diagnostic information are continually passed onto the fieldbus during each device transmission. Most engineering tools and/or system/host workstations provide the ability to view such information. Dynamic variable status contains two components: data quality and sub-status. The following table briefly outlines the dynamic variable status.

Quality	Sub-status
Good (non-cascade)	<ol style="list-style-type: none"> <li>1) Nonspecific.</li> <li>2) Active alarm block.</li> <li>3) Block has active advisory alarm.</li> <li>4) Block has active alarm with priority <math>&gt;</math> or <math>=</math> 8.</li> <li>5) Block has unacknowledged alarm.</li> <li>6) Unacknowledged advisory alarm.</li> <li>7) Unacknowledged critical alarm.</li> </ol>
Uncertain	<ol style="list-style-type: none"> <li>1) Nonspecific.</li> <li>2) Last usable value.</li> <li>3) Substitute.</li> <li>4) Initial value.</li> <li>5) Sensor conversion not accurate.</li> <li>6) EU range violation.</li> <li>7) Sub-normal.</li> </ol>
Bad	<ol style="list-style-type: none"> <li>1) Nonspecific.</li> <li>2) Configuration error.</li> <li>3) Not connected.</li> <li>4) Device failure.</li> <li>5) Sensor failure.</li> <li>6) No communication, with last usable value.</li> <li>7) No communication, with no last usable value.</li> <li>8) Block Out of Service.</li> </ol>

In addition to the dynamic variable status, Block Error Parameters provide error status of hardware or software components that are associated with and/or directly impact the correct operation of the Transducer Block. The three parameters include BLOCK\_ERR, block alarm sub-code, and XD\_ERROR. The BLOCK\_ERR parameter can have several status conditions. The block alarm sub-code and XD\_ERROR parameters provide additional information on the diagnostic condition. The following table lists the possible items that can be used for these three parameters.

BLOCK_ERR	Block Alarm Sub-code	XD_ERROR
1) Other 2) Block Configuration Error 3) Link Configuration Error 4) Simulate Active 5) Local Override 6) Device Fault State Set 7) Device Needs Maintenance Soon 8) Input Failure/PV has Bad Status 9) Output Failure 10) Memory Failure 11) Lost Static Data 12) Lost NV Data 13) Readback Check Failed 14) Device Needs Maintenance Now	Any one BLOCK_ERR or XD_ERROR condition.	1) Unspecified Error 2) General Error 3) Calibration Error 4) Configuration Error 5) Electronics Failure 6) Mechanical Failure 7) I/O Failure 8) Data Integrity Error 9) Software Error 10) Algorithm Error

Transmitter diagnostic conditions (i.e., Problem and Error Codes) are displayed as Extended Status information. Since these conditions have an impact on the Dynamic Variable quality and Block parameters, each diagnostic condition has been mapped as follows:

Problem/Error Code and Text Prompt		Problem & Error Description	PV Status	SV1 Status	SV2 Status	TB Block_err	TB Block Alarm Sub-code	TB Xd_error
Code	Text							
EC1	PV.AD	Process Variable Over/Under Range	Bad (Device failure)	N/A	Bad (Device failure)	Input Failure, Needs Maintenance Now, Other	Electronics Failure	Electronics Failure
EC3 EC4 EC6	xx.PCB	Incorrect Input Board	Bad (Device Failure)	Bad (Device Failure)	Bad (Device Failure)	Input Failure, Device Needs Maintenance Now, Other	Electronics Failure	Electronics Failure
PC3	DRTY.SN	Dirty sensor detected	Uncertain (Sensor Conversion Not Accurate)	N/A	Uncertain (Sensor Conversion Not Accurate)	Device Needs Maintenance Now	Device Needs Maintenance Now	Device Needs Maintenance Now
PC4	GND.LP	Ground loops present or shorted sensor cable.	Bad (Sensor Failure)	N/A	Bad (Sensor Failure)	Device Needs Maintenance Now	Device Needs Maintenance Now	Device Needs Maintenance Now
PC8	HI.PV	PV above/below transmitter range.	Uncertain (EU Range Violation)	N/A	N/A	Device Needs Maintenance Now, Other	Mechanical Failure	Mechanical Failure
PC9	LO.PV							
PC10	HI.TEMP	Temperature above/below transmitter range.	Uncertain (Sensor Conversion Not Accurate)	Uncertain (EU Range Violation)	Uncertain (Sensor Conversion Not Accurate)	Block Configuration Error, Device Needs Maintenance Now, Other	Mechanical Failure	Mechanical Failure
PC11	LO.TEMP							
PC12	TEMP.AD	Open, missing or shorted temperature sensor.	Uncertain (Sensor Conversion Not Accurate)	Bad (Sensor Failure)	Uncertain (Sensor Conversion Not Accurate)	Block Configuration Error, Device Needs Maintenance Now, Other	Configuration Error	Configuration Error
PC20	BAD.SEE	Bad EEPROM or bad input PCB assembly	Uncertain (Sensor Conversion Not Accurate)	Uncertain (Sensor Conversion Not Accurate)	Uncertain (Sensor Conversion Not Accurate)	Lost Static Data	Data Integrity	Data Integrity
PC21	NO.F.CAL	Missing factory calibration	Uncertain (Sensor Conversion Not Accurate)	Uncertain (Sensor Conversion Not Accurate)	Uncertain (Sensor Conversion Not Accurate)	Lost Static Data	Data Integrity	Data Integrity
PC30 to PC44	xx.F.CAL	SEE PV fac cal errors	Uncertain (Sensor Conversion Not Accurate)	N/A	Uncertain (Sensor Conversion Not Accurate)	Lost Static Data	Data Integrity	Data Integrity

Problem/Error Code and Text Prompt		Problem & Error Description	PV Status	SV1 Status	SV2 Status	TB Block_err	TB Block Alarm Sub-code	TB Xd_error
Code	Text							
PC45 to PC47	xx.F.CAL	SEE Temp fac cal errors	Uncertain (Sensor Conversion Not Accurate) when TEMP_COMP_TYPE is AUTOMATIC	Uncertain (Sensor Conversion Not Accurate)	Uncertain (Sensor Conversion Not Accurate) when TEMP_COMP_TYPE is AUTOMATIC	Lost Static Data	Data Integrity	Data Integrity
PC50 to PC64	xx.CHKS	SEE PV checksum errors	Uncertain (Sensor Conversion Not Accurate)	N/A	Uncertain (Sensor Conversion Not Accurate)	Lost Static Data	Data Integrity	Data Integrity
PC65 to PC67	xx.CHKS	SEE Temp checksum errors	Uncertain (Sensor Conversion Not Accurate) when TEMP_COMP_TYPE is AUTOMATIC	Uncertain (Sensor Conversion Not Accurate)	Uncertain (Sensor Conversion Not Accurate) when TEMP_COMP_TYPE is AUTOMATIC	Lost Static Data	Data Integrity	Data Integrity
PC70	GL.AD	Ground Loop signal above/below transmitter A/D range.	Uncertain (Sub-normal)	N/A	Uncertain (Sub-normal)	Device Needs Maintenance Soon	Device Needs Maintenance Soon	Device Needs Maintenance Soon
PC72	DS.AD	Dirty Sensor diagnostic signal above/below transmitter A/D range.	Uncertain (Sub-normal)	N/A	Uncertain (Sub-normal)	Device Needs Maintenance Soon	Device Needs Maintenance Soon	Device Needs Maintenance Soon

PV represents Primary Values and SV represents Secondary Value.

The **Alert Notification** Mechanism is used to inform a master device of an error. In addition, Alert Notifications provide some information on process conditions and events and are automatically sent to a master device. So whenever an alarm or an error condition enables an Alert Notification, the alert is received at the master device as one of four reported states: Acknowledged, Unacknowledged, Reported, or Unreported.

#### Alarm Summary

Whenever an alarm is enabled and the alarm condition occurs, notification at the Master device is initiated by using an Alert Notification and setting the relevant bit in the Current Alarms field. The Unacknowledged field reflects if the alarm has been recognized at the Master device. The Unreported field reflects if the alarm was linked to a system at which each alarm event has to be reported.

Alarm Type	Description
Discrete Alarm	Supported only by the Resource Block. When the Hardware (Switch 1) and/or Software write locks have been set.
HI_HI_Alarm	Supported by AI. Notified when the OUT value goes above the HI_HI_LIM value and when the OUT value drops back down below the HI_HI_LIM value. Alarm state and time stamp only recorded when HI_HI_PRI is non-zero.
HI_Alarm	Supported by AI. Notified when the OUT value goes above the HI_LIM value and when the OUT value drops back down below the HI_LIM value. Alarm state and time stamp only recorded when HI_PRI is non-zero.
LO_LO_Alarm	Supported by AI. Notified when the OUT value goes below the LO_LO_LIM value and when the OUT value rises back over the LO_LO_LIM value. Alarm state and time stamp only recorded when LO_LO_PRI is non-zero.
LO_Alarm	Supported by AI. Notified when the OUT value goes below the LO_LIM value and when the OUT value rises back over the LO_LIM value. Alarm state and time stamp only recorded when LO_PRI is non-zero.
Block Alarm	Supported by RB, TB and AI. Notify when a Block Error occurrence is encountered for the relating block. See Block Error.

Limit alarm bits are set to 1 or 0. A '1' represents an active alarm and a '0' represents an inactive alarm in the Current Alarms field.

# DISMANTLING AND REASSEMBLY

**Warning.**  
 Substitution of any components other than those assemblies listed in this section will compromise the certification listed on the transmitter nameplate. Invalidating the certifications can lead to unsafe conditions that can injure personnel and damage equipment.

**Caution.**  
 Dismantling and reassembly should not be carried out on site because of the risk of damage to components and printed circuits as a result of adverse environmental conditions such as humidity, dust, etc. The dismantling and reassembly procedures given below should be carried out in the listed order to avoid instrument damage.

## Required tools

Medium flat-bladed screwdriver  
 Small Phillips screwdriver

## Dismantling

- Use the bladed screwdriver to loosen the four captive screws that secure the Front Bezel and/or Rear Cover Assemblies (depending on which component is being replaced) and remove the cover(s).

- Remove Power Supply and/or Input PCB Assemblies by unscrewing the two Phillips screws and unplug the assemblies from their connectors.
- Remove Microprocessor/Display PCB Assembly by unscrewing the four Phillips screws and unplug the keypad cable by lifting the locking arms on the side of the connector and remove the cable from the connector.
- Remove the cable hubs by screwing the retaining nut and removing the hub from the Shell Assembly.

## Reassembly

Check that the gaskets are not damaged and have a thin layer of silicone grease. If the gaskets are damaged, replace gaskets.

- Install the Microprocessor/Display by securing the assembly with the four Phillips screws and installing the keypad cable into the connector and locking it into place by pushing down the two locking arms on the side of the connector.
- Install the Power Supply and/or Input PCB Assemblies into their respective connector and secure the assemblies with the two Phillips screws per assembly.
- Attach cable hubs by installing the gaskets onto the hubs and insert the hubs into the ports in the Shell assembly. Secure the hubs by tightening the nut onto the hub threads.
- Install the Front Bezel and/or Rear Cover Assemblies and secure by tightening the four captive screws per assembly using a bladed screwdriver.

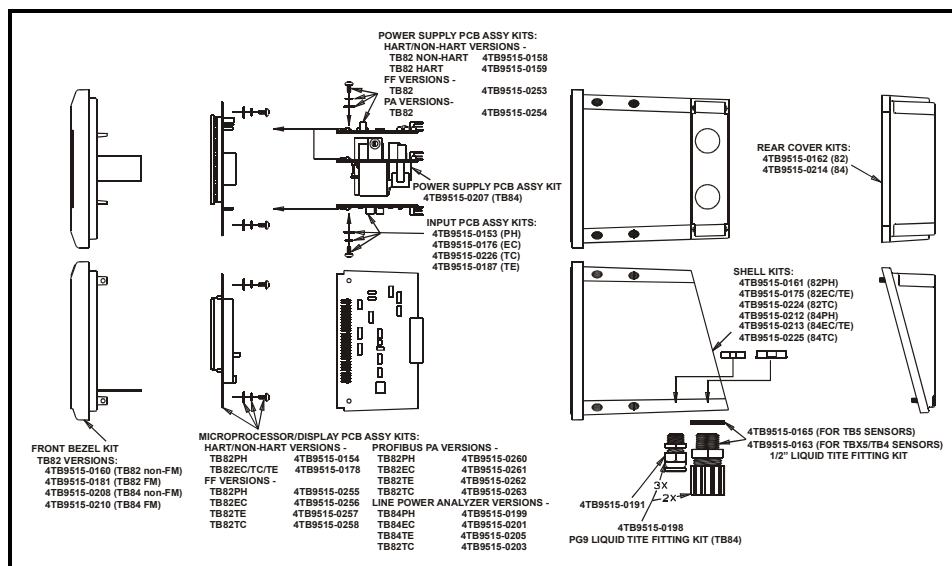

Figure 36 - TB82EC FF Transmitter Exploded View

## SPECIFICATIONS

Property	Characteristic/Value
Process Display Range Conductivity Concentration	0.000 $\mu\text{S/cm}$ to 1999 mS/cm 0.000 to 1999 Digits (EU Configurable)
Temperature Display Range	-20° to 300°C (-4° to 572°F).
Sensor Full Scale Measurement Ranges	Sensor Group A - 0 to 1999 mS/cm Sensor Group B - 0 to 1999 $\mu\text{S/cm}$ Sensor Group C - 0 to 199.9 $\mu\text{S/cm}$
Resolution, Display Conductivity  Concentration Temperature	Sensor Group A: 0.1 $\mu\text{S/cm}$ Sensor Group B: 0.01 $\mu\text{S/cm}$ Sensor Group C: 0.001 $\mu\text{S/cm}$ 0.001 Digits (Configuration Dependent) 1°C, 1°F.
Accuracy, Display Conductivity Temperature	$\pm 0.5\%$ Measurement Range per Decade 1°C
Nonlinearity, Display Conductivity Temperature	$\pm 0.5\%$ Measurement Range per Decade 1°C
Repeatability, Display Conductivity Temperature	$\pm 0.5\%$ Measurement Range per Decade 1°C
Stability, Display Conductivity Temperature	$\pm 2$ LSD Typical; 5 LSD Maximum 1°C
Temperature Compensation	Manual (0.1N KCl based) Automatic - Configurable as: Standard (0.1N KCl based) Coefficient (0 to 9.99%/°C adjustable) 0 to 15% NaOH 0 to 20% NaCl 0 to 18% HCl 0 to 20% H <sub>2</sub> SO <sub>4</sub> Pure Water - Neutral Salt Pure Water - Acid Pure Water - Base User Defined
Input Types Conductivity/ Concentration Temperature	ABB Four-Electrode Conductivity Sensors ABB Four-Electrode Conductivity Sensors 3 kohm Balco, Pt100, Standard 4.75 kohm Network
Dynamic Response	3 sec. for 90% step change at 0.00 sec. damping.
Ambient Temperature Effect Conductivity t	$\pm 0.1\%$ /°C FS @ 95% Relative Humidity $\pm 0.2\%$ /°C Displayed Value @ 95% Relative Humidity
Minimum Span Conductivity  Concentration Temperature	Sensor Group A: 100 $\mu\text{S/cm}$ Sensor Group B: 10 $\mu\text{S/cm}$ Sensor Group C: 1.000 $\mu\text{S/cm}$ 5% Maximum Concentration Range 10 °C

<b>Property</b>	<b>Characteristic/Value</b>
Maximum Span (full scale settings) Conductivity	Sensor Group A: 1999 mS/cm Sensor Group B: 1999 $\mu$ S/cm Sensor Group C: 199.9 $\mu$ S/cm
Concentration Temperature	1999 Digits 200 °C, 360 °F (0 to 200 °C, 32 to 392 °F)
Damping	Continuously adjustable from 0.0 to 99.9 seconds
Supply Voltage	9 to 32 Vdc (9 to 24 Vdc for agency certified IS applications) 15 mA quiescent current
Turn-On Time	4 seconds typical, 6 seconds maximum
Maximum Sensor Cable Length	100 ft (30.5 m) Sensor Group A 50 ft (15.2 m) Sensor Group B 25 ft (7.6 m) Sensor Group C
Sensor Diagnostic	Ground-Loop Detection, Dirty Sensor, Slope and Offset Check
Diagnostic Notification Local HMI	FAULT icon indication.
Environmental Operating temperature LCD Range Storage temperature	-20° to 60°C (-4° to 140°F) -20° to 60°C (-4° to 140°F) -40° to 70°C (-40° to 158°F)
Mounting Effect	None
Enclosure Classification	NEMA 4X IP65
Size Height Minimum panel depth Maximum panel cutout Recommended panel cutout	144 mm high x 144 mm wide x 171 mm long (5.66 in. high x 5.66 in. wide x 6.70 in. long) 145 mm (5.70 in.) 136.7 mm x 136.7 mm (5.38 in. x 5.38 in.) 135 mm x 135 mm (5.33 in. x 5.33 in.)
Weight	4.2 lb (1.9 kg) without mounting hardware 7.5 lb (3.4 kg) with Pipe Mounting Hardware

Property	Characteristic/Value
EMC Requirements	CE certified: Electromagnetic Conformance - IEC61326-1: 2000  EN55011: 1991 (CISPR11: 1990) Class A EN61000-4-2: 1995 4 kV Contact 6 kV Indirect EN61000-4-3: 1997 10 V/m EN61000-4-4: 1995 1 kV EN61000-4-5: 1995 2kV Line to Earth 1kV Line to Line EN61000-4-6: 2001 3V EN61000-4-8: 1994 30A/m
Agency Approvals <sup>1</sup> (pending) Factory Mutual (FM) Intrinsic safety  Nonincendive  Canadian Standards Association (CSA) Intrinsic safety  Nonincendive  CENELEC (Conforms with ATEX 100A) Intrinsic safety	Class I, II, III; Division 1; applicable Groups A, B, C, D, E, F and G; T4 when used with appropriate barriers per Drawing PXXXX.  Class I, Division 2, Groups A, B, C, and D. Class II, Division 2, Groups E, F and G. Class III, Division 2.  Class I, II, III; Division 1; applicable Groups A, B, C, D, E, F and G; T4 when used with appropriate barriers per Drawing PXXXX.  Class I, Division 2, Groups A, B, C, and D. Class II, Division 2, Groups E, F and G. Class III, Division 2.  ATEX Category II 1G EEX ia, Zone 1; Group IIC, T4 when used with appropriate barriers.

<sup>1</sup> Hazardous location approvals for use in flammable atmospheres are for ambient conditions of -20C to 60 C (-4 F to 140 F), 86 to 108 kPa (12.5 to 15.7 psi) with a maximum oxygen concentration of 21%.

## GLOSSARY OF PROGRAMMING TEXT PROMPTS

TEXT STRING	DESCRIPTION
3K.BLCO	3 kohm Balco (Temperature Compensation).
4.75K.RTD	4.75 kohm RTD Network.
A GRP	Sensor Group A.
AAAAAA	Alphanumeric Entry.
ACID	Pure Water with trace Acid temperature compensation.
AI-.BLK	Analog Input Block where '-' is the block number.
AI-.FV	Analog Input Field Value where '-' is the block number.
AI-.OUT	Analog Input Output value where '-' is the block number.
AI-.PV	Analog Input Process Value where '-' is the block number.
ANALZR	Analyzer State.
AUTO	Automatic Temperature Compensation (Nernstian) or Automatic Block Mode Handling.
B GRP	Sensor Group B.
BAD.CAL	Bad Calibration - Entered values caused the calculated values to exceed maximum values.
BAD.VAL	Bad Value - Entered value exceeded maximum allowable value for the entered parameter.
BASE	Pure Water with trace Base temperature compensation.
C GRP	Sensor Group C.
CALIBR	Calibrate Mode.
CON.CAL	Conductivity or Concentration Calibration State.
CONCEN	Concentration Analyzer State.
COND	Conductivity Mode.
CONFIG	Configure Mode.
D.P.POS	Decimal Point Position.
DAMPNG	Damping of the displayed primary value on the transmitter's HMI.
DENIED	An incorrect security password has been entered.
DIAGS	Diagnostics State.
DISABL	Disable.
EDT.CAL	Edit Calibrate State.
ENABLE	Enable.
FF.ID	Foundation Fieldbus Identification.
HARD.LK	Operation cannot be completed due to Hardware write protection.
H2SO4	Sulfuric Acid.
HCL	Hydrochloric Acid.
K1/K25	Conductivity at Temperature to the Temperature Compensated Conductivity at the reference temperature for Point #1. Points 2 through 6 are represented in the same manner.
MANUAL	Manual Temperature Compensation (Nernstian).
MODIFY	Modify Configure State.
NACL	Sodium Chloride.
NAOH	Sodium Hydroxide.
NEUTRL	Neutral.
NEW.VAL	New Calibration Value - The PV or Temperature value expected during a One Point or Temperature Calibration.
NEW.VL.C	New Temperature Value in degrees Celsius.
NEW.VL.F	New Temperature Value in degrees Fahrenheit.
NO D.P.	No Decimal Point is desired.
NO.ICON	No Icon is desired in the primary display.
NONE	None.
OFFSET	Offset Value.
OUT.CAL	Output Calibration State.
OOS	Out Of Service.
OUTPUT	Output Mode.
PASSWD	Security Password.
PT 100	Pt100 Ohm RTD.

TEXT STRING	DESCRIPTION
PUR.H2O	Pure Water.
PV OFF	Process Variable Offset Value for the installed sensor.
PV SLP	Process Variable Slope Value for the installed sensor.
RESET?	Query to Reset parameters to default values.
REV.A10	Software Revision A10.
RST.ALL	Reset All Parameters to Factory Settings.
RST.CAL	Reset Calibration Constant and Data to Factory Settings.
RST.CON	Reset Configurations to Factory Defaults.
RST.SEC	Reset Security - Remove any existing security.
RST.SFT	Software Reset - Initiate a reboot and self-test function.
SAVE?	Would you like to Save the Configuration?
SEC.DSP	Secondary Display Mode.
SECUR	Security Mode.
SLOPE	Slope for the installed sensor (Process Variable or Temperature).
STABL?	Is the displayed Process Variable Stable?
T.OFF°C	Temperature Offset in degrees Celsius.
T.OFF°F	Temperature Offset in degrees Fahrenheit.
TC.COEF	Temperature Compensation Coefficient.
TC.TYPE	Temperature Compensation Type State.
TB.OOS?	Transducer Block will be put Out Of Service?
TB.PV.LO	Transducer Block Process Value Low Range Value.
TB.PV.HI	Transducer Block Process Value High Range Value.
TB.RNGE	Transducer Block Range Value State.
TC.TYPE	Temperature Compensation Type State
TMP	Temperature.
TMP.CAL	Temperature Calibration State.
TMP.SLP	Temperature Slope Value.
TMP.SNS	Temperature Sensor Type State.
TMP°C	Temperature in degrees Celsius.
U.D.UNIT	User-defined Engineering Unit.
UNITS	Units.
USER	User State.
USR.DEF	User-defined.
VIEW	View Current Configuration.
WRT.ERR	Error saving data.
X1.COND	Conductivity independent variable (i.e., X Point) value for break point 1 in conductivity units. Points 2 through 6 are represented in the same manner.
Y1.CONC	Concentration dependent variable (i.e., Y Point) value for break point 1 in concentration units. Points 2 through 6 are represented in the same manner.



---

## PRODUCTS & CUSTOMER SUPPORT

---

### A Comprehensive Instrumentation Range

---

#### Analytical Instrumentation

---

- **Transmitters**

On-line pH, conductivity, and dissolved oxygen transmitters and associated sensing systems.

- **Sensors**

pH, redox, selective ion, conductivity and dissolved oxygen.

- **Laboratory Instrumentation**

pH and dissolved oxygen meters and associated sensors.

- **Water Analyzers**

For water quality monitoring in environmental, power generation and general industrial applications including:

pH, conductivity, ammonia, nitrate, phosphate, silica, sodium, chloride, fluoride, dissolved oxygen, hydrazine, and turbidity.

- **Gas Analyzers**

Zirconia, katharometers, hydrogen purity and purge-gas monitors, thermal conductivity.

---

#### Controllers & Recorders

---

- **Controllers**

Digital display, electronic, pneumatic. Discrete single-loop and multi-loop controllers which can be linked to a common display station, process computer or personal computer.

- **Recorders**

Circular and strip-chart types (single and multi-point) for temperature, pressure, flow and many other process measurements.

#### Electronic Transmitters

- **Smart & Analog Transmitters**

Draft, differential, gauge and absolute pressure measurement. Also, liquid level and temperature.

- **I to P Converters and Field Indicators**

---

#### Flow Metering

---

- **Magnetic Flowmeters**

Electromagnetic, insertion type probes and water meters.

- **Turbine Flowmeters**

- **Wedge Flow Elements**

- **Mass Flow Meters**

Transmitters, sensors, controllers and batch/display units.

---

#### Level Control

---

- **Submersible, Capacitance & Conductivity.**

---

#### Pneumatic Instrumentation

---

- **Transmitters**

- **Indicating Controllers**

- **Recording Controllers**

### Customer Support

ABB Instrumentation provides a comprehensive after sales service via a Worldwide Service Organization. Contact one of the following offices for details on your nearest Service and Repair Center.

#### United States of America

##### ABB Inc.

9716 S. Virginia St., Suite E  
Reno, Nevada 89511  
USA

Tel: +1 (775) 850 4800

Fax: +1 (775) 850 4808

#### United Kingdom

ABB Instrumentation Limited

Oldends Lane  
Stonehouse, Glos.

UK, GL10 3TA

Tel: +44 (0)1453 826-661

Fax: +44 (0)1453 827-856

#### Client Warranty

Prior to installation, the equipment referred to in this manual must be stored in a clean, dry environment, in accordance with the Company's published specification. Periodic checks must be made on the equipment's condition.

In the event of a failure under warranty, the following documentation must be provided as substantiation:

1. A listing evidencing process operation and alarm logs at time of failure.
2. Copies of operating and maintenance records relating to the alleged faulty unit.

TROUBLE SHEET



**TROUBLE SHEET**

WARRANTY REPAIR   REPAIR ORDER

Rejection or discrepancy reports

Copy attached  Not available

● IDENTIFICATION

Customer			
Purchase	order	No.	
Plant			
Name	of	person	to contact
Instrument			Nomenclature
Model			
Serial Number			

● OPERATING CONDITIONS

Specify location, environmental conditions, type of service and approximate number of operating hours or date of installation if known.

● REASON FOR RETURN

Trouble found during: Installation  Commissioning  Maintenance   
At start up  On service

Shipping information for the return of the equipment

Material returned for factory repair, should be sent to the nearest ABB Service Center, transportation charges prepaid by the Purchaser.

Please enclose this sheet duly completed to cover letter and packing list

Date  Signature  Originator

## EC DECLARATION OF CONFORMITY

ABB Inc.  
9716 S. Virginia St., Suite E  
Reno, Nevada 89511  
USA

We declare under our sole responsibility that the product:

TB82EC Foundation Fieldbus Transmitter Series

is in conformity with the following standards:

Electromagnetic Conformance - IEC61326-1: 2000

EN55011: 1991 (CISPR11: 1990)	Class A
EN61000-4-2: 1995	4 kV Contact
	6 kV Indirect
EN61000-4-3: 1997	10 V/m
EN61000-4-4: 1995	1 kV
EN61000-4-5: 1995	2kV Line to Earth
	1kV Line to Line
EN61000-4-6: 2001	3V
EN61000-4-8: 1994	30A/m

following the provisions of the EMC Directives 89/336/EEC and 93/68/EEC.

ABB Incorporated  
Technical Manager  
Stewart Thoeni



ABB ([www.abb.com](http://www.abb.com)) is a leader in power and automation technologies that enable utility and industry customers to improve performance while lowering environmental impact. The ABB Group of companies operates in around 100 countries and employs about 105,000 people.

[www.abb.com/instrumentation](http://www.abb.com/instrumentation)

The Company's policy is one of continuous product improvement and the right is reserved to modify the information contained herein without notice.  
Printed in USA (February, 2002)  
© ABB 2002

# ABB

**USA**

**ABB Inc.**  
125 E. County Line Rd.  
Warminster, PA 18954  
USA

Tel: +44 (0)1453 826661  
Fax: +44 (0)1453 829671

**USA**

**ABB Inc.**  
9716 S. Virginia St., Suite E  
Reno, Nevada 89511  
USA

Tel: +1 (775) 850 4800  
Fax: +1 (775) 850 4808

**UK**

**ABB Ltd**  
Oldends Lane, Stonehouse  
Gloucestershire, GL10 3TA  
UK

Tel: +44 (0)1453 826661  
Fax: +44 (0)1453 829671