

# Integral Orifice Flow Element

## 1/2, 1, 1-1/2" Pipe Sizes

Model 1330L

- 1/2 , 1 and 1-1/2" NPT sizes
- $\pm 0.5\%$  accuracy
- Flanged construction
- Wide variety of standard bores
- One-year warranty

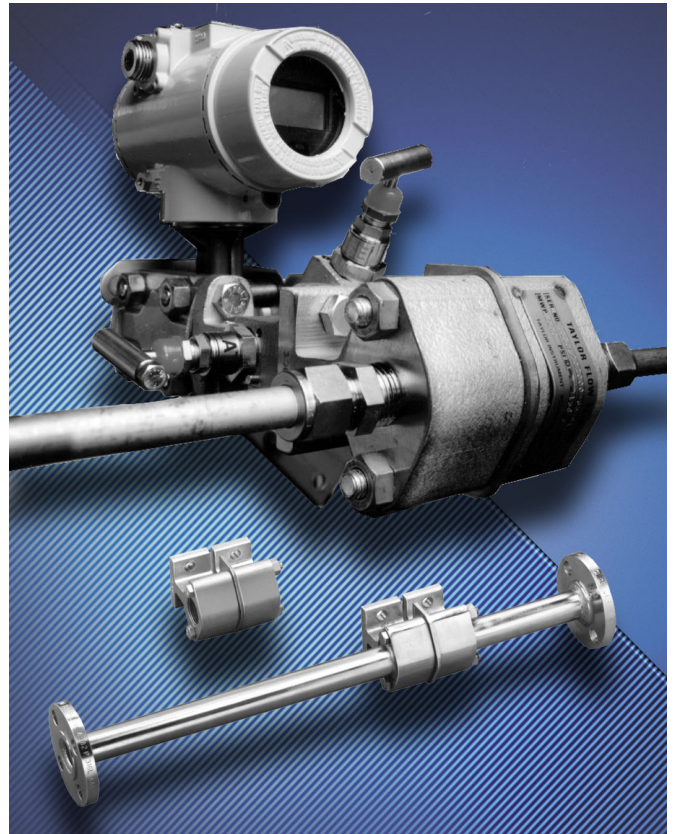

Integral Orifice Flow Elements  
Model 1330L

## Integral Orifice Flow Element 1/2, 1, 1-1/2" Pipe sizes, Model 1330L

The integral orifice is a flow element capable of being close coupled with differential pressure transmitters to make a complete flow meter. It provides easy-to-install, low-cost measurement of the small flows found frequently in plant metering operations and research projects. It can be ordered with internal NPT threads or flanged pipe runs, welded both upstream and downstream of the flow restriction. The orifice assembly may be directly mounted to the transmitter or remote using optional adapter kit 155S711.

### PERFORMANCE SPECIFICATIONS

#### Accuracy

##### Calibrated

±0.5% of actual flow when operated within the calibrated range using the average value of K

##### Uncalibrated Orifice Bores

0.020-0.065 ±5% of rate  
0.113-0.500 ±2% of rate  
0.612-1.127 ±1.5% of rate

#### Pressure Rating

##### Threaded

1/2 in. and 1 in. NPT: 3000 psig (21 000 kPa)  
at 300°F (150°C)  
1-1/2 NPT: 1500 psig (10 500 kPa)  
at 300°F (150°C)

##### Flanged

Class 150 ANSI: 275 psig (1900 kPa) MWP  
at 100°F (38°C)  
Class 300 ANSI: 720 psig (5000 kPa) MWP  
at 100°F (38°C)

### PHYSICAL SPECIFICATIONS

#### Materials of Construction

Threaded type body 316 SST,  
Orifice plate 316 SST, Hastelloy-C<sup>1</sup>  
Flanged type element All 316 SST only  
Sealing gasket Silicate ceramic filled TFE

#### Concentric Orifice Bores

1/2 in. 0.020, 0.035, 0.065, 0.113, 0.150, 0.196,  
0.270, 0.340 in.  
1 in. 0.020, 0.035, 0.065, 0.113, 0.150,  
0.196, 0.270, 0.340, 0.500, 0.612,  
0.735 in.  
1-1/2 in. 0.500, 0.612, 0.750, 0.918, 1.127 in.

#### Pipe Size

1/2, 1 and 1-1/2 in.

#### Pipe Schedule

Schedule 40, 80<sup>(2)</sup>

#### Connection to Transmitter

Flat gasketed surfaces bolted to transmitter or  
3-valve manifold.

#### Face to Face Dimensions

Threaded type 1/2 and 1 in.: 3-11/16 in.  
(93.7 mm)  
1-1/2 in.: 4-1/16 in. (103.2 mm)  
Flanged type 1/2 & 1 in.: 24 in. (609.6 mm) length  
1-1/2 in.: 38 in. (965.2 mm) length

#### NACE Standard

Construction materials 316 SST with 316 SST  
orifice plate and 316 SST and Hastelloy C orifice  
plate conform to NACE Standard MR-0175-88.  
Conformance is on process wetted materials only  
and does not include bolting.

#### Temperature Rating

300°F (148.9°C) max.

#### Weights

##### 1330L

No Flanges	
(1/2 in. and 1 in.)	4.9 lb (2.2 kg)
(1-1/2 in.)	7.5 lb (3.4 kg)
Class 150 ANSI Flange	
(1/2 in. and 1 in.)	11.6 lb (5.3 kg)
Class 300 ANSI Flange	
(1/2 in. and 1 in.)	17.6 lb (8 kg)
Class 150 ANSI Flange	
(1-1/2 in.)	18.8 lb (8.5 kg)
Class 300 ANSI Flange	
(1-1/2 in.)	24.8 lb (11 kg)

## DETERMINATION OF DIFFERENTIAL PRESSURE AND ORIFICE BORE

### Differential Pressure

To calculate exact differential pressure produced at known flow rate, use one of the following equations:

$$\text{Liquid: } h = gf \left[ \frac{q(\text{in U.S. qpm})}{5.668 \times F_a \times K \times d^2} \right]^2$$

$$\text{Gas: } h = \frac{GT_f}{P_f} \left[ \frac{Q(\text{in scfh})}{7727 \times F_a \times F_{pv} \times K \times d^2 \times Y} \right]^2$$

$$\text{Steam: } h = V \left[ \frac{W(\text{lb/hr})}{359 \times F_a \times K \times d^2 \times Y} \right]^2$$

- d = bore diameter in inches
- F<sub>a</sub> = thermal expansion factor of orifice plate
- G = specific gravity of gas
- g<sub>f</sub> = specific gravity of liquid at flow conditions
- h = differential pressure in in.H<sub>2</sub>O
- K = flow coefficient
- P<sub>f</sub> = process pressure in psia (psig + 14.7)
- Q = flow rate of gas
- q = flow rate of liquid
- T<sub>f</sub> = process temperature in °R (°F + 460)
- V = specific volume of steam in cu ft/lb
- W = flow rate of steam
- Y = gas expansion factor

- F<sub>pv</sub> = gas supercompressibility  $F_{pv} = \sqrt{\frac{Z_b}{Z_F}}$
- Z<sub>b</sub> = basic compressibility
- Z<sub>F</sub> = flowing compressibility

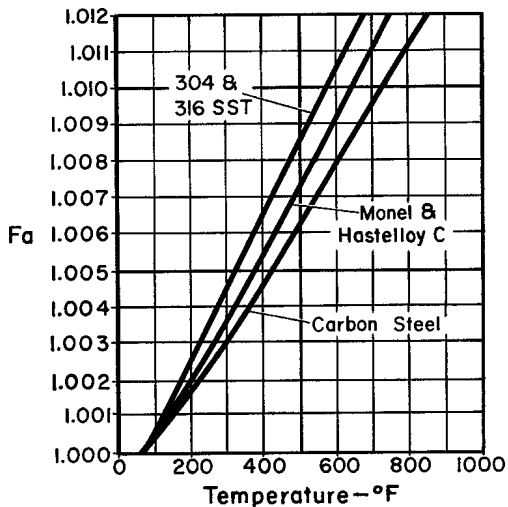

A-904-50(1)

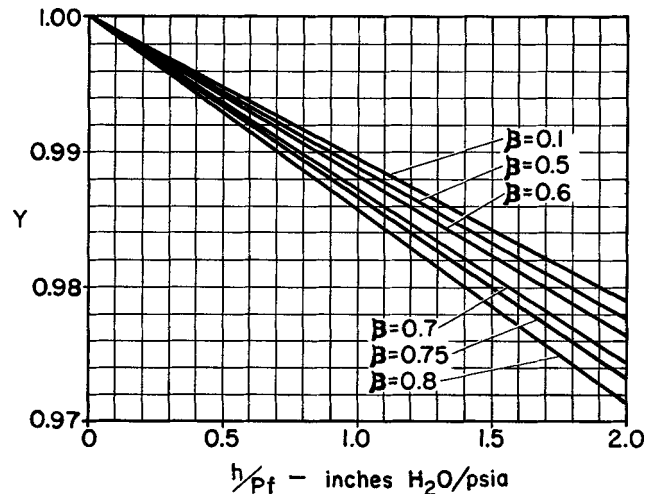

A-904-51(1)

**ORIFICE CAPACITIES**

**1/2 inch Integral Orifice Capacity Table**

Orifice Bore (Inches)	Differential Pressure (Inches H <sub>2</sub> O)	Liquid <sup>1</sup> Flow Rate US gpm	Gas <sup>2</sup> Flow Rate scfh	Saturated Steam <sup>3</sup> Flow Rate pph
0.020	200	0.020	12.8	0.6
	100	0.0014	9.1	0.5
	50	0.010	6.4	0.3
	20	0.006	4.1	0.2
	10	0.004	2.9	0.1
0.035	200	0.060	38.7	1.9
	100	0.043	27.3	1.4
	50	0.030	19.3	1.0
	20	0.019	12.2	0.6
	10	0.014	8.6	0.4
0.065	200	0.205	131.0	6.6
	100	0.145	92.6	4.7
	50	0.102	65.5	3.3
	20	0.065	41.4	2.1
	10	0.046	29.3	1.5
0.113	200	0.616	394.5	19.8
	100	0.436	279.0	14.0
	50	0.308	197.3	9.9
	20	0.195	124.8	6.3
	10	0.138	88.2	4.4
0.150	200	1.086	695.2	34.9
	100	0.768	491.6	24.7
	50	0.543	347.6	17.5
	20	0.343	219.8	11.0
	10	0.243	155.4	7.8
0.196	200	1.863	1192.8	59.9
	100	1.317	843.4	42.4
	50	0.931	596.4	29.9
	20	0.589	377.2	18.9
	10	0.417	266.7	13.4
0.270	200	3.640	2330.9	82.8
	100	2.574	1648.2	58.5
	50	1.820	1165.4	37.0
	20	1.151	737.1	26.2
	10	0.814	521.2	117.0
0.340	200	6.051	3874.2	194.5
	100	4.279	2739.4	137.6
	50	3.025	1937.1	97.3
	20	1.913	1225.1	61.5
	10	1.353	866.3	43.5

**1-1/2 inch Integral Orifice Capacity Table**

Orifice Bore (Inches)	Differential Pressure (Inches H <sub>2</sub> O)	Liquid <sup>1</sup> Flow Rate US gpm	Gas <sup>2</sup> Flow Rate scfh	Saturated Steam <sup>3</sup> Flow Rate pph
0.500	200	12.244	7839.5	393.6
	100	8.658	5543.3	278.3
	50	6.122	3919.7	196.8
	20	3.872	2479.1	124.5
	10	2.738	1753.0	88.0
0.612	200	18.434	11802.6	592.6
	100	13.035	8345.7	419.1
	50	9.217	5901.3	296.3
	20	5.829	3732.3	187.4
	10	4.122	2639.1	132.5
0.750	200	28.090	17985.3	930.1
	100	19.863	12717.5	638.6
	50	14.045	8992.6	451.5
	20	8.883	5687.4	285.6
	10	6.281	4021.6	201.9
0.918	200	43.812	28051.6	1408.6
	100	30.980	19835.5	996.0
	50	21.906	14025.8	704.3
	20	13.855	8870.7	445.4
	10	9.797	6272.5	315.0

**1 inch Integral Orifice Capacity Table**

Orifice Bore (Inches)	Differential Pressure (Inches H <sub>2</sub> O)	Liquid <sup>1</sup> Flow Rate US gpm	Gas <sup>2</sup> Flow Rate scfh	Saturated Steam <sup>3</sup> Flow Rate pph
0.020	200	0.021	13.2	0.7
	100	0.015	9.4	0.5
	50	0.010	6.6	0.3
	20	0.007	4.2	0.2
	10	0.005	3.0	0.1
0.035	200	0.062	39.9	1.9
	100	0.044	28.2	1.4
	50	0.031	20.0	1.0
	20	0.020	12.6	0.6
	10	0.014	8.9	0.4
0.065	200	0.210	134.4	6.8
	100	0.148	95.1	4.8
	50	0.105	67.2	3.4
	20	0.066	42.5	2.1
	10	0.047	30.1	1.5
0.113	200	0.619	396.5	19.9
	100	0.438	280.4	14.1
	50	0.310	198.2	10.0
	20	0.196	125.4	6.3
	10	0.138	88.7	4.5
0.150	200	1.089	697.5	35.0
	100	0.770	493.2	24.8
	50	0.545	348.7	17.5
	20	0.344	220.6	11.1
	10	0.244	156.0	7.8
0.196	200	1.857	1188.9	59.7
	100	1.313	840.7	42.2
	50	0.928	594.4	29.8
	20	0.587	376.0	18.9
	10	0.415	265.8	13.3
0.270	200	3.529	2259.8	113.5
	100	2.496	1597.9	80.2
	50	1.765	1129.9	56.7
	20	1.116	714.6	35.9
	10	0.789	505.3	25.4
0.340	200	5.606	3589.4	180.2
	100	3.964	2538.1	127.4
	50	2.803	1794.7	90.1
	20	1.773	1135.1	57.0
	10	1.254	802.6	40.3
0.500	200	12.625	8083.3	405.9
	100	8.927	5715.7	287.0
	50	6.312	4041.6	202.9
	20	3.992	2556.2	128.4
	10	2.823	1807.5	90.8
0.612	200	20.055	12840.6	644.8
	100	14.181	9079.7	455.9
	50	10.028	6420.3	322.4
	20	6.342	4060.6	203.9
	10	4.484	2871.2	144.2
0.735	200	30.962	19823.8	995.4
	100	21.893	14017.5	703.9
	50	15.481	9911.9	497.7
	20	9.791	6268.8	314.8
	10	6.923	4432.7	222.6

1. Based on water flow at 60°F (15.6°C).
2. Based on air flow at 100 psig and 60°F, with base condition of 14.7 psia and 60°F (15.6°C)
3. Based on saturated steam flow at 100 psig.
4. These tables are for approximation purposes only.

### DIMENSIONS

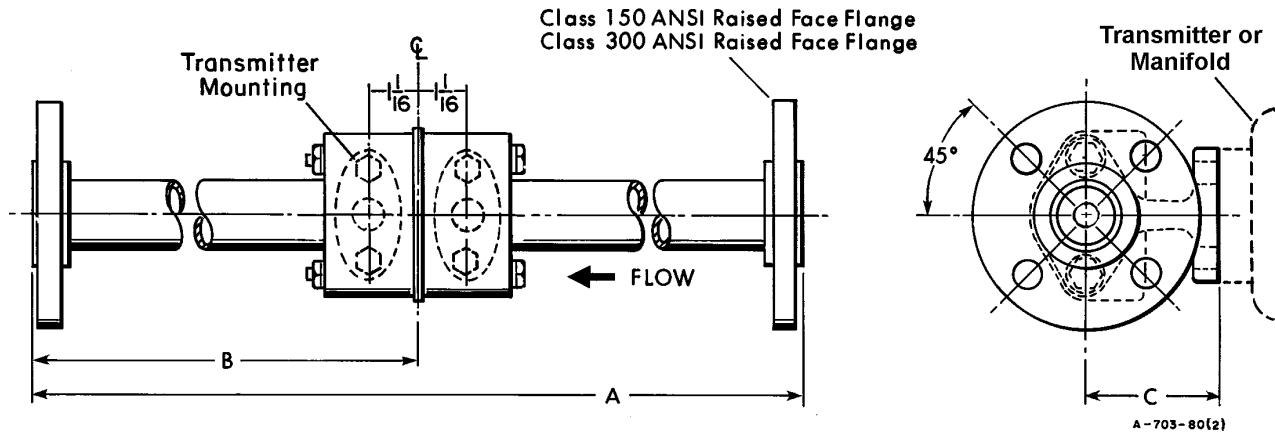

Part No	Pipe Size	A ± 3/16	B
1330LZ0	1/2	24	8
1330LZ1	1	24	8
1330LZ2	1	24	8
1330LZ3	1-1/2	38	8

Inches	MM
3/16	4.76
1-1/16	26.99
8	203.20
24	609.20
38	985.20

All dimensions in inches.

### 1/2" & 1" INTEGRAL ORIFICE FLOW ELEMENT

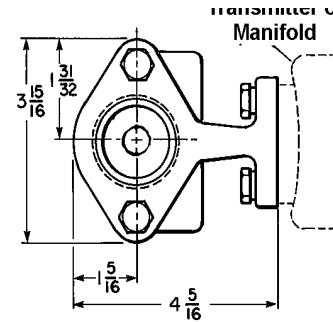
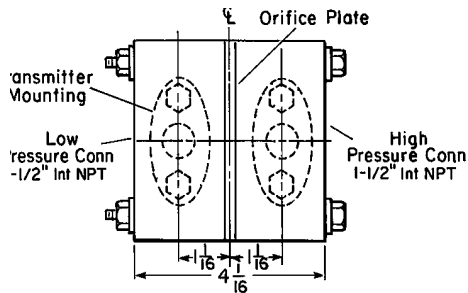

XB-1210-170(1)

### 1-1/2" INTEGRAL ORIFICE FLOW ELEMENT

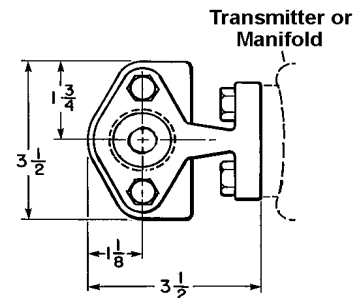
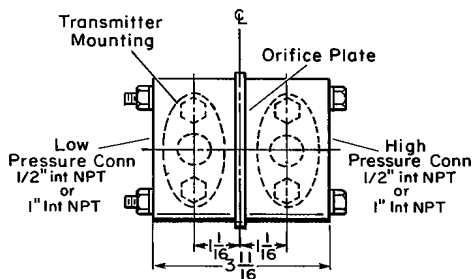

XB-1210-171(2)

INCHES	mm	INCHES	mm
1/2	12.7	1-31/32	50.01
1	25.4	3-1/2	88.9
1-1/8	28.57	3-11/16	93.66
1-1/16	26.99	3-15/16	100.01
1-5/16	33.34	4-1/16	103.9
1-1/2	38.10	4-5/16	109.54
1-3/4	44.45		

## Model Number Designation

1330L    Z    06    07    08    09    10    11

Unused - Unused .....	Z						
<b>Pipe and Bore Size</b> (no piping, no flanges, select from 9th character)							
1/2 in. (13 mm), 0.020 in. (0.51 mm) .....							01
1/2 in. (13 mm), 0.035 in. (0.89 mm) .....							02
1/2 in. (13 mm), 0.065 in. (1.65 mm) .....							03
1/2 in. (13 mm), 0.113 in. (2.87 mm) .....							04
1/2 in. (13 mm), 0.150 in. (3.81 mm) .....							05
1/2 in. (13 mm), 0.196 in. (4.98 mm) .....							06
1/2 in. (13 mm), 0.270 in. (6.86 mm) .....							07
1/2 in. (13 mm), 0.340 in. (8.64 mm) .....							08
1/2 in. (13 mm), special bore size (2) .....							09
1 in. (25 mm), 0.150 in. (3.81 mm) .....							11
1 in. (25 mm), 0.270 in. (6.86 mm) .....							12
1 in. (25 mm), 0.612 in. (15.54 mm) .....							13
1 in. (25 mm), 0.020 in. (0.51 mm) .....							21
1 in. (25 mm), 0.035 in. (0.89 mm) .....							22
1 in. (25 mm), 0.065 in. (1.65 mm) .....							23
1 in. (25 mm), 0.113 in. (2.87 mm) .....							24
1 in. (25 mm), 0.196 in. (4.98 mm) .....							25
1 in. (25 mm), 0.340 in. (8.64 mm) .....							26
1 in. (25 mm), 0.500 in. (12.70 mm) .....							27
1 in. (25 mm), 0.735 in. (18.67 mm) .....							28
1 in. (25 mm), special bore size (2) .....							29
1-1/2 in. (40 mm), 0.500 in. (12.70 mm) .....							31
1-1/2 in. (40 mm), 0.612 in. (15.54 mm) .....							32
1-1/2 in. (40 mm), 0.750 in. (19.05 mm) .....							33
1-1/2 in. (40 mm), 0.918 in. (23.32 mm) .....							34
1-1/2 in. (40 mm), 1.127 in. (28.63 mm) .....							35
1-1/2 in. (40 mm), special bore size (2) .....							39
<b>Upstream, Downstream Piping and Mating Flange Connection</b>							
No pipe, no flanges .....							0
Class 150 ANSI flange and Schedule 40 pipe							
1/2 in. and 1 in. ....							1
1-1/2 in. ....							1
Class 300 ANSI flange and Schedule 40 pipe							
1/2 in. and 1 in. ....							2
1-1/2 in. ....							2
Class 150 ANSI flange and Schedule 80 pipe							
1/2 in. and 1 in. ....							A
1-1/2 in. ....							A
Class 300 ANSI flange and Schedule 80 pipe							
1/2 in. and 1 in. ....							B
1-1/2 in. ....							B
<b>Construction Material</b>							
316 SST body with 316 SST orifice plate - NACE .....							0
316 SST body with Hastelloy C <sup>1</sup> orifice plate - NACE .....							4
Reserved for special constructions that do not comply with NACE .....							9
<b>Calibration</b>							
No calibration .....							0
Water calibration .....							1
No calibration with transmitter mounting .....							A
Water calibration with transmitter mounting .....							B
Instruction Manual (One copy supplied with order at No Charge) .....							IB-04H104

<sup>1</sup>Trademark of Haynes International, Inc.

<sup>2</sup>Special bore size to be specified at time of order placement

## **Model Number Designation**

### **Optional Extras:**

Orifice bore Calculation (Applies to Special Bore Only)

#### **Replacement Orifice Plate Kits**

Consist of standard bore orifice plate and two silicone-ceramic filled TFE gaskets.

Adapter Kit 155S711 for remote mounting of transmitter.

Oxygen Service Cleaning - per CGA-G4.

*Notes*

---

ABB has Sales & Customer Support  
expertise in over 100 countries worldwide

[www.abb.com/instrumentation](http://www.abb.com/instrumentation)

The Company's policy is one of continuous product  
improvement and the right is reserved to modify the  
information contained herein without notice.

Printed in USA (2.13.06)

© ABB 2006



**ABB Inc.**  
125 East County Line Road  
Warminster  
PA 18974  
USA  
Tel: +1 215 674 6000  
Fax: +1 215 674 7183

**ABB Limited**  
Salterbeck Trading Estate  
Workington, Cumbria  
CA14 5DS  
UK  
Tel: +44 (0)1946 830 611  
Fax: +44 (0)1946 832 661