

ABB Actuator & Positioners Valve and damper controls in power plants

Industry: **Power**

Improved valve and damper controls boost power plant efficiencies

Precise positioning accuracy and quick response of final control elements can maximize efficiency of fossil-fuel power stations

A variety of factors are pressuring power utilities to improve the efficiency of fossil fuel power stations. These include strict environmental specifications, climate protection goals, frequent load changes, and changing fuels and fuel energy values. Load changing frequencies result from the growing use of regenerative power sources such as wind and solar energy. Additionally, low-cost, exotic fuels such as forest wood residues, used plastics, and biosludge have considerable variations in energy value.

Solutions to these challenges incorporate precise, continuous positioning of final control elements in specific areas of the plant. These areas include the injection valves on the steam vessels for optimizing the turbine inlet temperature and the corresponding fuel and air controls. The high ambient temperatures in these areas often complicate matters.

Controlling injection valves

Final control elements in fossil fuel power stations must cope with high dynamic process conditions, frequent plant startup and shutdown phases as well as variation in fuel quality. These factors, in combination with operational constraints and challenges, demand high performance and reliability of critical components such as injection valves for cooling water in the superheater and reheater. The function of the injection valves is to cool down the superheated steam to the optimal turbine inlet temperature.

Deficiencies such as switching frequency limitations cause considerable variations in the amount of cooling water delivered, which affects the temperature of the superheated steam. As a result, plants take control measures to adjust the temperature so that peaks will be

within the specified range. The primary goal of these measures is to protect the superheater, turbine, and secondary plant components against overload. However, this safety comes at the cost of reduced turbine efficiency, which is lowered by up to 0.05% for every reduction of the turbine inlet temperature by 1°C. This means that an average deviation of the superheated steam temperature from the optimal turbine inlet temperature by only 20°C will reduce efficiency by up to 1%. Although these reduced efficiencies can lead to significant economic losses, many power plants unknowingly still use electrical actuators with limited duty cycles, such as S4-25% duty, or S5-25% duty per IEC60034-1 specification. Plant engineers and operators are often not aware of the fact that the duty type specification applies to a moderate ambient temperature of 20°C.



As is generally known, a body's cooling curve follows an E-function over time and is dependant on the temperature difference between the body and its environment. The smaller the temperature difference, the longer the cooling time needed. The duty cycle restriction of electric motors is primarily intended to keep their self-heating within acceptable limits. High ambient temperatures prolong the cooling time. Rising ambient temperatures decrease the permissible duty cycle. For example, S5-25% duty at 20°C becomes S5-13% duty at 50°C. This means precision control of high dynamic applications in high temperature conditions becomes impossible.



Valves on steam vessels control the amount of cooling water injected into the superheated steam in the superheater and reheater

Poor positioning accuracy causes undesired process variability disproportionately amplified throughout the valve range. Without cost-intensive special measures like split-range arrangements or valves with pre-cones, an undesirable pressure surge results. The need for high resolution final control element actuation of at least 0.1% is required.

Assuming an appropriate process controller, the following applies: the more precise and responsive the final control element in following the setpoint under all ambient conditions, the smaller the output variation. This means that the selection of the appropriate valve actuator has a tremendous influence on controlling a process close to its setpoint.

Actuators of the ABB Contrac series are an excellent fit for these injection valve applications. Working in mode S9-100% duty per EN IEC 60034-1 specification, they ensure precise, continuous and responsive valve positioning. Special high temperature options permit unlimited S9-100% duty operation at ambient temperatures up to 85°C. IP 66 protection of all components makes these actuators suitable for use in even the harshest environments.

Contrac actuator positioning accuracy of $\pm 0.05\%$ permits precise valve control. The improved control that results allows the turbine to quickly reach and keep close to its operating setpoint. The positive effect on plant efficiency results in a fast payback of the higher performing final control actuators.

Optimizing combustion parameters

Responsive, precise control of the fuel and air final control elements associated with combustion offer additional saving potential for fossil fuel power stations. The combustion process itself has a major impact on the energy efficiency and effective heat-rate of fossil fuel power station operation. Contrac continuous electrical actuators can optimize combustion as they ensure the appropriate ratio of air, fuel, and operating pressure. The result is improved fuel consumption along with reduced CO₂ and NO_x emissions.

Less than optimal air leads to incomplete and uneconomical combustion, while an excess of air means suboptimal combustion and higher fuel expenses as well as escalating cost for exhaust gas purification to meet clean air requirements. Additionally, an excess of air results in higher demands on fans, which often requires throttling back the burner air supply and fresh air dampers. The entire process and mechanical elements can be negatively affected by poor combustion. The more precise and responsive the control of the air supplies for combustion, the more environmentally friendly and economical the combustion process.

In many fossil fuel power stations, exhaust gas parameters control combustion. The long time lag usually associated with these systems restricts burner control potential. Operators often use an unnecessarily high excess of air to keep within safety limits of boiler designs. Fluctuating fuel energy values increase the difficulty of quickly adapting combustion parameters. Advanced technologies like thermal imaging may eventually make combustion control more responsive to changing conditions.

Contrac actuators from ABB also offer significant cost saving potential for these applications since their highly precise and responsive positioning performance provide outstanding fuel efficiency.



ABB Contrac continuous control actuators ensure precise positioning of the injection valves as well as all valves and dampers affecting combustion.

Authors:

Thomas Kleegrewe is senior product manager of the "Electrical actuators & positioners" division in ABB Automation Products GmbH

Stephan Schulze is the product manager in charge of Contrac electrical actuators in ABB Automation Products GmbH.

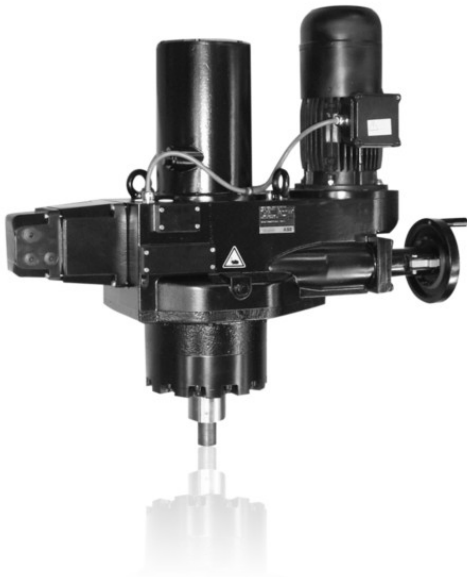
Horst Bender is responsible for the management of the power industry sector in ABB Automation Products GmbH.

Contact:

ABB Instrumentation

125 East County Line Road

Warminster, PA 18974 USA

Tel: +1 215 674 6000

Fax: +1 215 674 7183

www.abb.com/instrumentation

© ABB 2010 A-A-Power_Contrac_A Printed in U.S. (1.15.10)

© ABB 2000, 2010 A-A-Power_Contrac_A Printed in U.S. (1.7.10)