

**INSTRUCTION BULLETIN
VORTEX FLOWMETERS
10VR1000A
FIRMWARE A.52**

10VR1000 Vortex 4™ FLOWMETERS

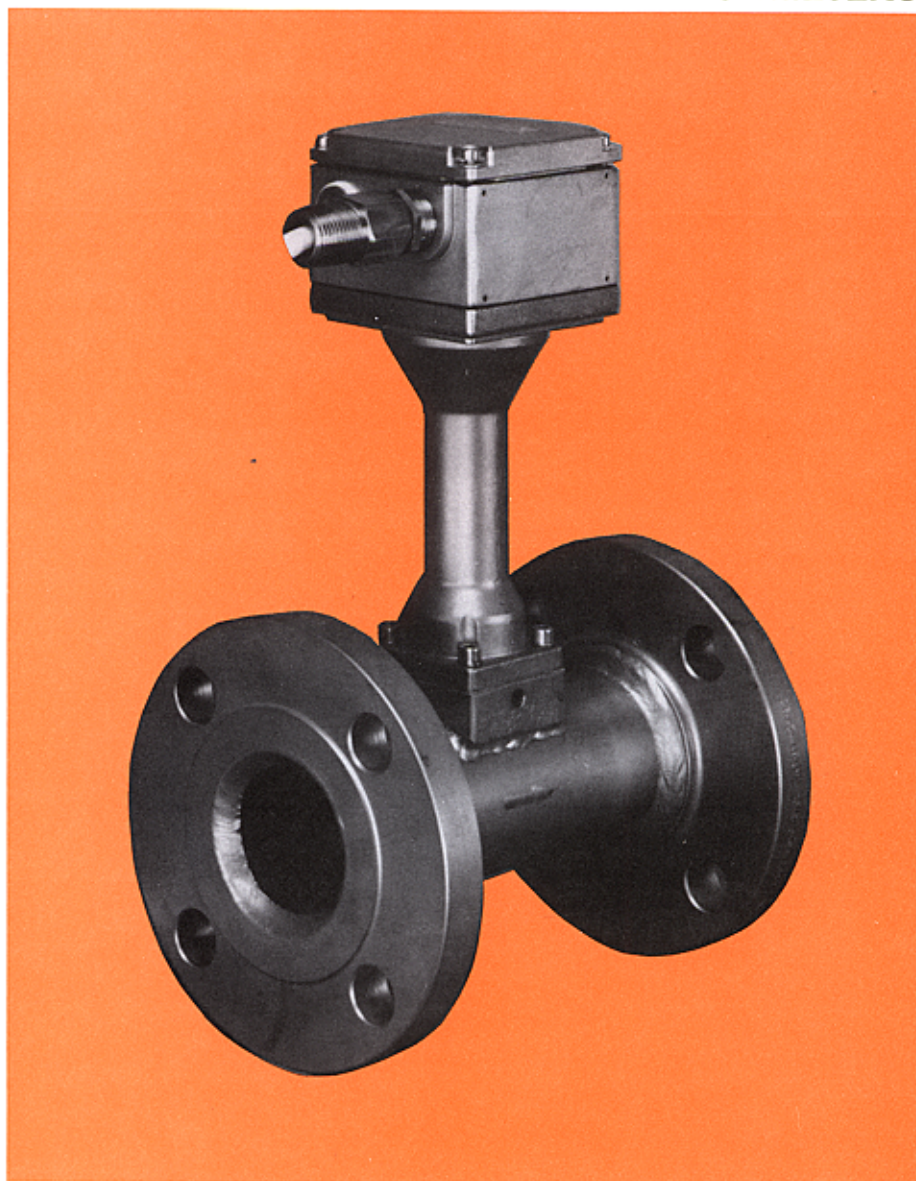

PN 24796

The following are registered trademarks of Du Pont:

TEFLON®
VITON®
KALREZ®

The following is a registered trademark of HART Communication Foundation:

HART®

WARNING notices as used in this manual apply to hazards or unsafe practices which could result in personal injury or death.

CAUTION notices apply to hazards or unsafe practices which could result in property damage.

NOTES highlight procedures and contain information which assist the operator in understanding the information contained in this manual.

All software, including design, appearance, algorithms and source codes, is copyrighted by Elsag Bailey Process Automation and is owned by Elsag Bailey Process Automation or its suppliers.

WARNING

POSSIBLE PROCESS UPSETS

Maintenance must be performed only by qualified personnel and only after securing equipment controlled by this product. Adjusting or removing this product while it is in the system may upset the process being controlled. Some process upsets may cause injury or damage.

NOTICE

The information contained in this document is subject to change without notice.

Elsag Bailey Process Automation, its affiliates, employees, and agents, and the authors of and contributors to this publication specifically disclaim all liabilities and warranties, express and implied (including warranties of merchantability and fitness for a particular purpose), for the accuracy, currency, completeness, and/or reliability of the information contained herein and/or for the fitness for any particular use and/or for the performance of any material and/or equipment selected in whole or part with the user of/or in reliance upon information contained herein. Selection of materials and/or equipment is at the sole risk of the user of this publication.

This document contains proprietary information of Elsag Bailey Process Automation, and is issued in strict confidence. Its use, or reproduction for use, for the reverse engineering, development or manufacture of hardware or software described herein is prohibited. No part of this document may be photocopied or reproduced without the prior written consent of Elsag Bailey Process Automation.

**ADDENDUM TO
VORTEX / SWIRL FLOWMETER
INSTRUCTION BULLETINS**

This addendum modifies information contained in the following Vortex & Swirlmeter Instruction Bulletins:

10VT1000	PN24795
10VR1000	PN24796
10ST1000	PN24793
10SR1000	PN24794

The purpose of this addendum is to revise the **NOTE** statement in **Section 4.3.16 Range Minimum (Q_{min})** of Chapter 4.0 - Start-Up and Operation in the Instruction Bulletins referenced above.

The statement has been revised to read as follows:

NOTE
If Mass Flow or Standard Flow is selected as the flow mode in Section 4.3.8, the units of Range Min. will continue to be displayed in the volumetric flow units selected in Section 4.3.12.

This information replaces the corresponding information presently given in the above Instruction Bulletins. All other Instruction Bulletin parameters remain unchanged.

**CONVERSION INSTRUCTIONS
3-WIRE SENSOR TO 2-WIRE CONFIGURATION**

The purpose of this addendum is to provide information for converting three-wire Vortex and Swirlmeter sensors to two-wire configuration where applicable. Newer models of Vortex (Models 10VT) and Swirlmeters (Models 10ST) have terminal blocks that have been designed for use with 3-wire sensors. Models 10VM & 10VR and 10SM & 10SR continue to use 2-wire input terminal blocks and use the 3-wire sensor configured to a 2-wire mode as shown in the illustration below.

The 2-wire sensor configuration is also required when retrofitting older Vortex 10VT and Swirlmeter 10ST models with the new 3-wire sensors since the older models contain 2-wire terminal blocks on the circuit board.

3-WIRE SENSOR PART NUMBERS

B-F&P PART NUMBER	METER SIZE	GASKET TYPE	MATERIAL	LENGTH
D693B027U01 D693B027U09 D693B027U11 D693B027U03	1/2 - 6 inch (DN15 - DN150)	Flat O-Ring O-Ring Flat	Steel 1.4571 " " Hastelloy C	Standard
D693B029U01 D693B029U09 D693B029U11 D693B029U03	≥ 8 inch (≥ DN200)	Flat O-Ring O-Ring Flat	Steel 1.4571 " " Hastelloy C	Long

The sensors listed above have three wires:

- one **blue** lead
- one **red** lead
- one **yellow** lead

To convert the sensors to 2-wire mode:

- twist **yellow & red** wires together
- connect **yellow/red** wires to terminal 19 on the PCB terminal block
- connect **blue** wire to terminal 2B on the PCB terminal block

Refer to the generic cutaway diagram shown on the right for dressing and connection of the sensor leads. The diagram shows the newer "tower assembly" construction. Older "tower assemblies" will have different construction from that shown.

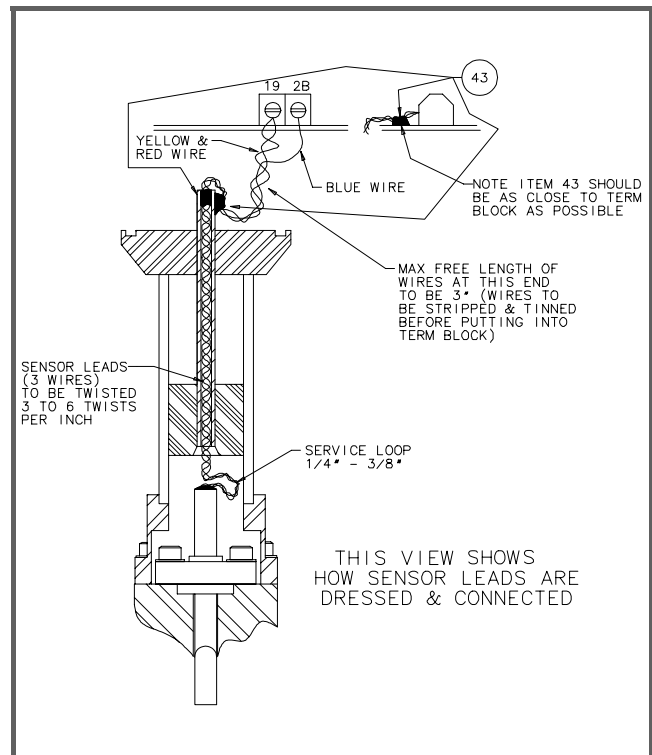

Table of Contents

SAFETY SUMMARY	I
READ FIRST	II
1.0 INTRODUCTION	1-1
1.1 Description	1-1
1.2 Principle of Operation	1-1
1.3 Back Pressure Requirements for Liquid Flow	1-1
1.4 Model Number Breakdown	1-2
1.5 Specifications	1-4
2.0 INSTALLATION	2-1
2.1 Inspection	2-1
2.2 Location and Mounting	2-1
2.2.1 Flowmeter	2-1
2.2.2 Signal Converter	2-1
2.2.3 Extreme Temperature Applications	2-2
2.3 Temperature/Pressure Monitoring	2-2
2.4 Meter Weights	2-3
2.5 Meter Installation	2-3
2.6 Electrical Interconnections	2-4
2.7 Conduit Seal and Pressure Relief	2-6
3.0 DATA ENTRY AND CONFIGURATION	3-1
3.1 Pushbuttons and Display	3-1
3.2 Pushbutton Functions	3-1
3.3 Instructions for Entering Data Into the Converter	3-3
3.4 Parameter Summary and Data Entry	3-4
4.0 START-UP AND OPERATION	4-1
4.1 Start-Up	4-1
4.2 Error Messages	4-1
4.3 Menu Display and Selections	4-1
4.3.1 Firmware Version	4-2
4.3.2 Program Protection	4-2
4.3.3 Language	4-4
4.3.4 Primary	4-4
4.3.5 Fluid	4-4
4.3.6 Meter Size	4-4
4.3.7 Median k-factor	4-5
4.3.8 Flow Mode	4-5
4.3.9 Compressibility	4-5
4.3.10 Unit Density	4-6

10SR1000 SWIRLMETER INSTRUCTION BULLETIN

4.3.11 Actual Density	4-6
4.3.12 Unit Qv (volumetric)	4-6
4.3.13 Unit Qm (mass flow)	4-7
4.3.14 Meter Range Maximum	4-7
4.3.15 Range Maximum	4-7
4.3.16 Range Minimum	4-8
4.3.16.1 Current Output vs. Range Min. Setting	4-8
4.3.17 Sub Menu Totalizer	4-9
4.3.17.1 Unit Totalizer	4-9
4.3.17.2 Totalizer	4-9
4.3.17.3 Overflow	4-9
4.3.17.4 Function Totalizer Reset	4-10
4.3.18 Sub Menu Pulse Output	4-10
4.3.19 Damping	4-10
4.3.20 Sub Menu Current Output	4-10
4.3.20.1 Current	4-10
4.3.20.2 I _{out} at Alarm	4-10
4.3.21 Sub Menu Display	4-11
4.3.21.1 Display 1. line	4-11
4.3.21.2 Display 2. line	4-11
4.3.22 Sub Menu Self Check	4-12
4.3.23 Sub Menu Error Register	4-13
4.3.23.1 Error Register	4-13
4.3.23.2 Mains Interrupt	4-13
4.3.24 Code Number (Calibration Parameters)	4-13
4.3.24.1 Instrument Number	4-14
4.3.24.2 Sub Menu k-factor	4-14
4.3.24.2.1 k-Factor linearization	4-15
4.3.24.2.2 Median k-factor	4-15
4.3.24.3 Selectable Meter Range Maximum	4-16
4.3.24.4 Function Reset Error	4-16
4.3.24.5 Function Initialize EEPROM	4-16
4.3.24.6 Function Adjust I _{out} 4 mA	4-17
4.3.24.7 Function Adjust I _{out} 20 mA	4-17
4.3.24.8 Function Minimum Current	4-17
4.3.24.9 Error Code 9	4-17
4.4 Analog Board Switches	4-18
5.0 TROUBLESHOOTING AND FLOW RATE TABLES	5-1
5.1 Troubleshooting	5-1
5.2 Flow Rates and Frequencies	5-3
6.0 PARTS LIST	6-1

Figure List

FIGURE 1-1 SWIRLMETER VORTEX GENERATION	1-1
FIGURE 1-2 SWIRLMETER OPERATING PRINCIPLE	1-2
FIGURE 1-3 PROCESS PRESSURE VS. TEMPERATURE	1-6
FIGURE 1-4 PROCESS OPERATING TEMPERATURES	1-7
FIGURE 1-5 LOAD RESISTANCE VS. POWER SUPPLY VOLTAGE	1-8
FIGURE 1-6. METER PIPING REQUIREMENTS	1-9
FIGURE 2-1. PRESSURE AND TEMPERATURE MEASUREMENT LOCATIONS	2-2
FIGURE 2-2. FLANGE BOLT TIGHTENING SEQUENCE	2-3
FIGURE 2-3. FLANGE PROCESS CONNECTIONS	2-4
FIGURE 2-4. PRIMARY CONNECTION BOARD LAYOUT	2-5
FIGURE 2-5. CONVERTER CONNECTION BOARD LAYOUT	2-5
FIGURE 2-6. CONVERTER ANALOG BOARD LAYOUT	2-6
FIGURE 2-7. CONDUIT ENTRY SEAL INSTALLATION	2-6
FIGURE 2-8. SWIRLMETER OUTLINE DIMENSIONS	2-7
FIGURE 2-9. SIGNAL CONVERTER MOUNTING & OUTLINE DIMENSIONS	2-8
FIGURE 2-10. INTERCONNECTION WIRING DIAGRAM FOR NON-HAZARDOUS LOCATIONS	2-9
FIGURE 2-11. INTERCONNECTION WIRING DIAGRAM FOR INTRINSICALLY SAFE LOCATIONS	2-10
FIGURE 3-1. PROGRAMMING PUSH-BUTTONS	3-1
FIGURE 4-1. FLOWCHART OF PARAMETERS	3-4
FIGURE 4-2. CURRENT OUTPUT OPERATION	3-9
FIGURE 4-3. ANALOG BOARD SWITCH LOCATIONS	4-18
FIGURE 6-1. FLOWMETER / SIGNAL CONVERTER PARTS	6-2

Table List

TABLE 1-1. AIR FLOW RATES	1-10
TABLE 1-2. GAS PRESSURE LOSS CALCULATIONS	1-10
TABLE 1-3. WATER FLOW RATES	1-11
TABLE 1-4. LIQUID PRESSURE LOSS CALCULATIONS	1-11
TABLE 1-5. AIR FLOW RATES AT SELECTED PRESSURES	1-12
TABLE 1-6. SATURATED STEAM FLOW RATES	1-13
TABLE 2-1. SWIRLMETER WEIGHTS	2-3
TABLE 4-1. DEFINITION OF ERROR MESSAGES	4-1
TABLE 4-2. UNITS OF MEASURE	4-2
TABLE 4-3. ANALOG BOARD FILTER SWITCH SETTINGS	4-19
TABLE 5-1. WATER FLOW RATES AND FREQUENCIES	5-3
TABLE 5-2. AIR FLOW RATES AND FREQUENCIES	5-3
TABLE 5-3. CONVERSION FACTORS	5-3
TABLE 6-1. FLOWMETER/SIGNAL CONVERTER PARTS LIST	6-3
TABLE 6-2. FLANGE GASKETS	6-3

SAFETY SUMMARY

GENERAL WARNINGS

POSSIBLE PROCESS UPSETS

Maintenance must be performed only by qualified personnel and only after securing equipment controlled by this product. Adjusting or removing this product while it is in the system may upset the process being controlled. Some process upsets may cause injury or damage.

RETURN OF EQUIPMENT

All Flowmeters and/or Signal Converters being returned to Bailey-Fischer & Porter for repair must be free of any hazardous materials (acids, alkalis, solvents, etc.). A Material Safety Data Sheet (MSDS) for all process liquids must accompany returned equipment. Contact Bailey-Fischer & Porter for authorization prior to returning equipment.

INSTRUCTION MANUALS

Do not install, maintain or operate this equipment without reading, understanding and following the proper Bailey-Fischer & Porter instructions and manuals, otherwise injury or damage may result.

SPECIFIC WARNINGS

When the meter is used in a very high or low temperature process, the temperature of the meter body may be extremely hot or cold. If it is necessary to touch the sensor housing or meter body, insulated gloves must be worn to prevent serious injury. (pg. 2-2)

All Flowmeters and/or Signal Converters being returned to Bailey-Fischer & Porter for repair must be free of any hazardous materials (acids, alkalis, solvents, etc.). A Material Safety Data Sheet (MSDS) for all process liquids must accompany returned equipment. Contact Bailey-Fischer & Porter for authorization prior to returning equipment. (pg. II, 4-1)

SPECIFIC CAUTIONS

The pipeline and meter body may be insulated by the user. However, the meter interconnection wiring box and the sensor housing tower must not be insulated. Ambient air is required to dissipate heat or cold build-up within the interconnection wiring box. (pg. 2-1)

All unused conduit entrances must have pipe plugs installed. This is required to maintain the NEMA 4X enclosure rating. (pg. 2-4)

READ FIRST

This Instruction Bulletin contains the following changes from the previous A.42 Firmware issue (PN24757):

- Changed .75 in. min. flow data in Tables 1-1, 1-3, 1-5 & 1-6
- Changed sensor material from 321 SS to 316 SS (German sensor)
- Revision of "K-Factor Correction" information in Section 1.4
- Maximum Range Max. entry reduced from 130% of Meter Range Max. to 115%
- Addition of "Standard Flow" mode to flow menu & display
- "Init. K-Factor", "HART-Enable" & "Totalizer Set " menus removed
- "HART Transmitter" , "HART Command" & "Test Fout" tests moved into "Self Check" sub-menu
- HART-Protocol "Special Commands" expanded
- Added Chapter 3.0 - Data Entry and Configuration
- Revised Table 4-3 - Analog Board Filter Switch Settings

WARNING

INSTRUCTION MANUALS

Do not install, maintain, or operate this equipment without reading, understanding and following the proper Bailey-Fischer & Porter instructions and manuals, otherwise injury or damage may result.

RETURN OF EQUIPMENT

All Flowmeters and/or Signal Converters being returned to Bailey-Fischer & Porter for repair must be free of any hazardous materials (acids, alkalis, solvents, etc). A Material Safety Data Sheet (MSDS) for all process liquids must accompany returned equipment. Contact Bailey-Fischer & Porter for authorization prior to returning equipment.

NEMA 4X, Corrosion Resistant Finish

This product is painted with a high performance epoxy paint. The corrosion protection provided by this finish is only effective if the finish is unbroken. It is the users' responsibility to "touch-up" any damage that has occurred to the finish during shipping or installation of the product. Special attention must be given to: meter flange bolting, pipe mounting of electronics, conduit entries and covers that are removed to facilitate installation or repair. For continued corrosion protection throughout the product life, it is the users' responsibility to maintain the product finish. Incidental scratches and other finish damage must be repaired and promptly re-painted with approved touch-up paint. Provide the model number and size of your product to the nearest Bailey-Fischer & Porter representative to obtain the correct touch-up paint.

Read these instructions before starting installation;
save these instructions for future reference.

1.0 INTRODUCTION

1.1 Description

The Bailey-Fischer & Porter 10VR1000 Vortex flowmeter is supplied with a microprocessor-based signal converter. The flowmeter and signal converter are interconnected by 15 feet (5 m) of signal cable. This arrangement allows the signal converter to be mounted a safe distance from the process fluid which may have an adverse effect on the signal converter electronics. The flowmeter, signal converter and signal cable are interconnected on-site. Refer to Figures 2-6 and 2-7.

This combination of flowmeter and electronics allows maximum flexibility for on-site calibration and maintenance. The three button keypad located in the signal converter interconnection box allows database interrogations and changes to the flowmeter. The two line, 16 character LCD display permits continuous monitoring of the flow rate and totalizer.

The flowmeter is suitable for service with gas and liquid processes. The meter's extended temperature range permits accurate metering of saturated and superheated steam.

The flowmeter body and process connections are made from 316L stainless steel. The sensor is made from 321 stainless steel. Because the meter has no moving parts, routine maintenance or recalibration is not required.

The 10VR1000 Vortex flowmeter is FM (Factory Mutual Research) approved as: Intrinsically Safe for Classes I, II and III, Division 1, Groups A, B, C, D, E, F and G, ENTITY; per ID-10-1104; Dust-ignitionproof for Class II Division 1, Groups E, F and G; Suitable for Class III Division 1; Nonincendive for Class I, Division 2, Groups A, B, C and D; for outdoor Hazardous (Classified) Locations; NEMA 4X.

1.2 Principle of Operation

In operation, as the incoming fluid is divided past the shedder bar, vortices are successively detached and appear alternately on either side of the sensor in the form of fluidic perturbations. As the vortices move downstream from the shedder bar, they produce an alternating pattern referred to as a Karman vortex street. Over the range of Reynolds numbers corresponding to the instrument range, the frequency of vortex formation is directly proportional to flow velocity and can be stated as shown in the following equation:

$$f = \frac{V}{d} \cdot St$$

where: f = vortex frequency
 V = inlet velocity
 d = width of shedder bar
 St = Strouhal number (constant over the range specified in the sizing tables)

1.3 Back Pressure Requirements for Liquid Flow

In order to prevent cavitation in the meter it is necessary to maintain a minimum back pressure in the system. The required back pressure is determined using the following formula:

$$P_b \geq 1.5P_v + 3\Delta P$$

where:

P_b = minimum required back pressure (psig)
 P_v = vapor pressure of the fluid at specified conditions (psig)
 ΔP = pressure drop (psig)

1.4 Model Number Breakdown

Refer to the Bailey-Fischer & Porter data sheet or the data tag on the equipment for the model number of the instrument furnished. The details of a specific number are shown on the following two pages:

	10VR1	-	-	1	A	-	-	1	-	C	-	2	A	A	-	A	
Engineering Reference																	
Integral Vortex Flowmeter																	
Process Connection																	
Flanged		1															
Wafer		3															
Fluid Type																	
Liquid		1															
Gas		2															
Natural Gas		3															
Saturated Steam		4															
Superheated Steam		5															
Other		6															
Materials of Construction																	
Body/Sensor 316L/321 Stainless Steel		1															
Design Level		A															
Meter Sizes																	
1 in. (25 mm)		B															
1 1/2 in. (40 mm)		C															
2 in. (50 mm)		D															
3 in. (80 mm)		E															
4 in. (100 mm)		F															
6 in. (150 mm)		G															
8 in. (200 mm)		H															
10 in. (250 mm)		J															
12 in. (300 mm)		K															
Flange Rating																	
ANSI Class 150 (PN10)		H															
ANSI Class 300 (PN16)		J															
Other		Z															
Temperature Range																	
-40° to 536° F (-40° to 280° C)		1															
Sensor Gasket																	
Graphite		1															
TEFLON (-20 to 230°C / -4 to 446°F)		2															

1.4 Model Number Breakdown (cont.)

10VR1	_	_	1	A	_	_	1	_	C	_	2	A	A	_	A					
Safety Approvals																				
FM Approved as: Intrinsically Safe for Classes I, II & III, Div.1, Groups A thru G, ENTITY; per CID-10-1107; Dust-ignitionproof for Class II Div.1, Groups E,F & G; Suitable for Class III, Div.1; Nonincendive for Class I, Div.2, Groups A,B, C & D; for outdoor Hazardous (Classified) Locations; NEMA 4X.										C										
Calibration																				
Dry Calibration, Gas & Liquid										1										
Liquid Calibration on Water										2										
Special Requirements										3										
Language																				
English											2									
Firmware Level																				
												A								
Operating Mode																				
Continuous Flow													A							
Options																				
None															0					
HART Protocol															1					
Power Supply																				
14 - 46 VDC																A				
Remote Electronics Mounting																				
Wall																		1		
2 inch Pipe																		2		

1.5 Specifications

Fluid Types

Gas, liquid or steam

Sizes

Flanged		Wafer	
inches	mm	inches	mm
1	25	---	---
1.5	40	1.5	40
2	50	2	50
3	80	3	80
4	100	4	100
6	150	6	150
8	200	8	200
10	250	---	---
12	300	---	---

Accuracy

± 0.75% of rate on liquids
 ± 1.0% of rate on gases & steam

Rangeability

Typically 20 to 1. Refer to Tables 1-1 through 1-5.

Process Pressure Limits

Flanged or wafer rated for ANSI Class 150 or 300 (DIN PN 10 - 16) service, 275/720 psig (1.91/4.96 MPa)

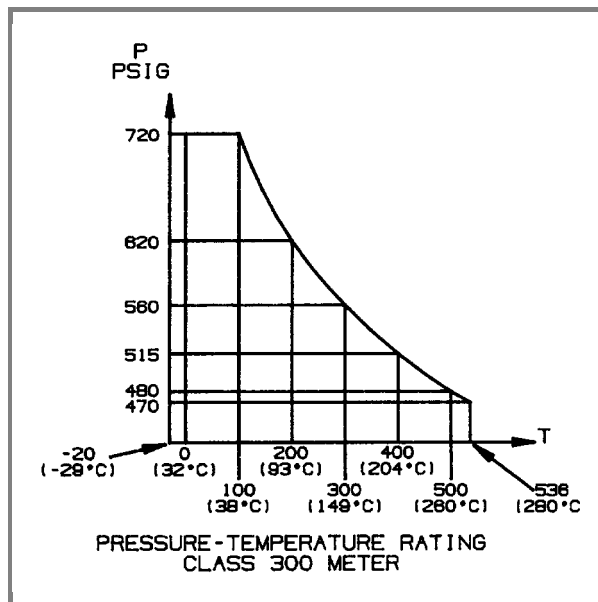
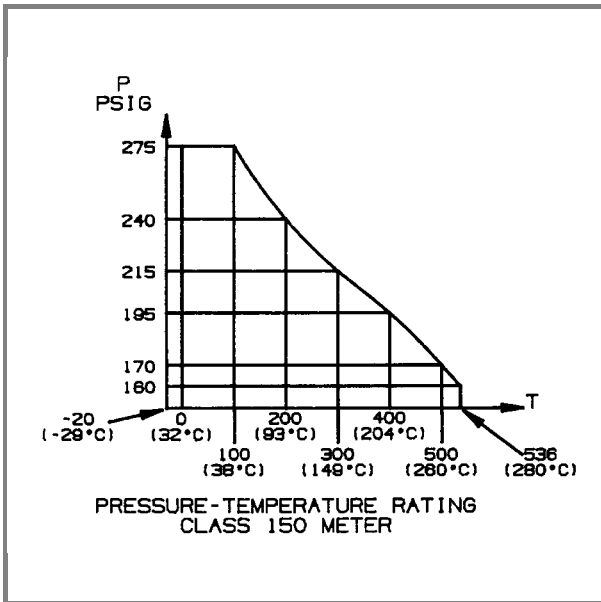

FIGURE 1-1 PROCESS PRESSURE vs. TEMPERATURE

Process Temperature Limits -40° to 536° F (-40° to 280° C)

Ambient Temperature Limits -10 to 140° F (-25 to 60° C)

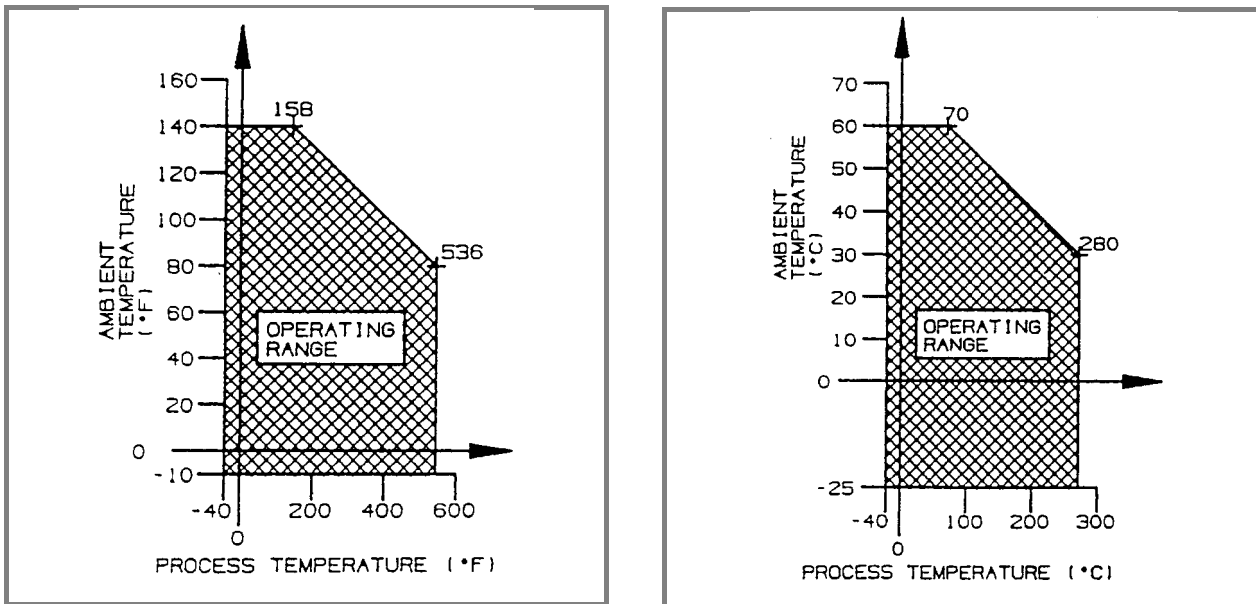

FIGURE 1-2 PROCESS OPERATING TEMPERATURES

Maximum Vibration Limits Air: 0.15g at 0 - 130 Hz
Water: 0.3g at 0 - 130 Hz

Relative Humidity Limits 5 - 95% non-condensing

Materials of Construction:

Signal Converter Housing	Diecast aluminum with epoxy paint NEMA 4X (IEC 529 IP65)
Body	316L SST
Sensor	321 SST
Sensor Gasket	Graphite (standard) TEFLON (optional)

Certifications Refer to Model Number Breakdown in Sub-Section 1.4.

K-Factor Correction Inlet pipe larger than Meter ID: no correction required
Inlet pipe ID smaller than Meter ID:

$$K_{\text{new}} = K_{\text{orig}} \times \left(\frac{\text{Meter ID}}{\text{Inlet Pipe ID}} \right)^2$$

where K_{new} = adjusted K-Factor

K_{orig} = calibrated K-Factor on instrument tag

Power requirements 14 - 46 V dc

Mounting

A minimum straight pipe run must be maintained up and downstream of the meter for various piping configurations. Refer to Figure 1-4 for minimum straight pipe run requirements. The Vortex-4 flowmeter can be installed at any attitude.

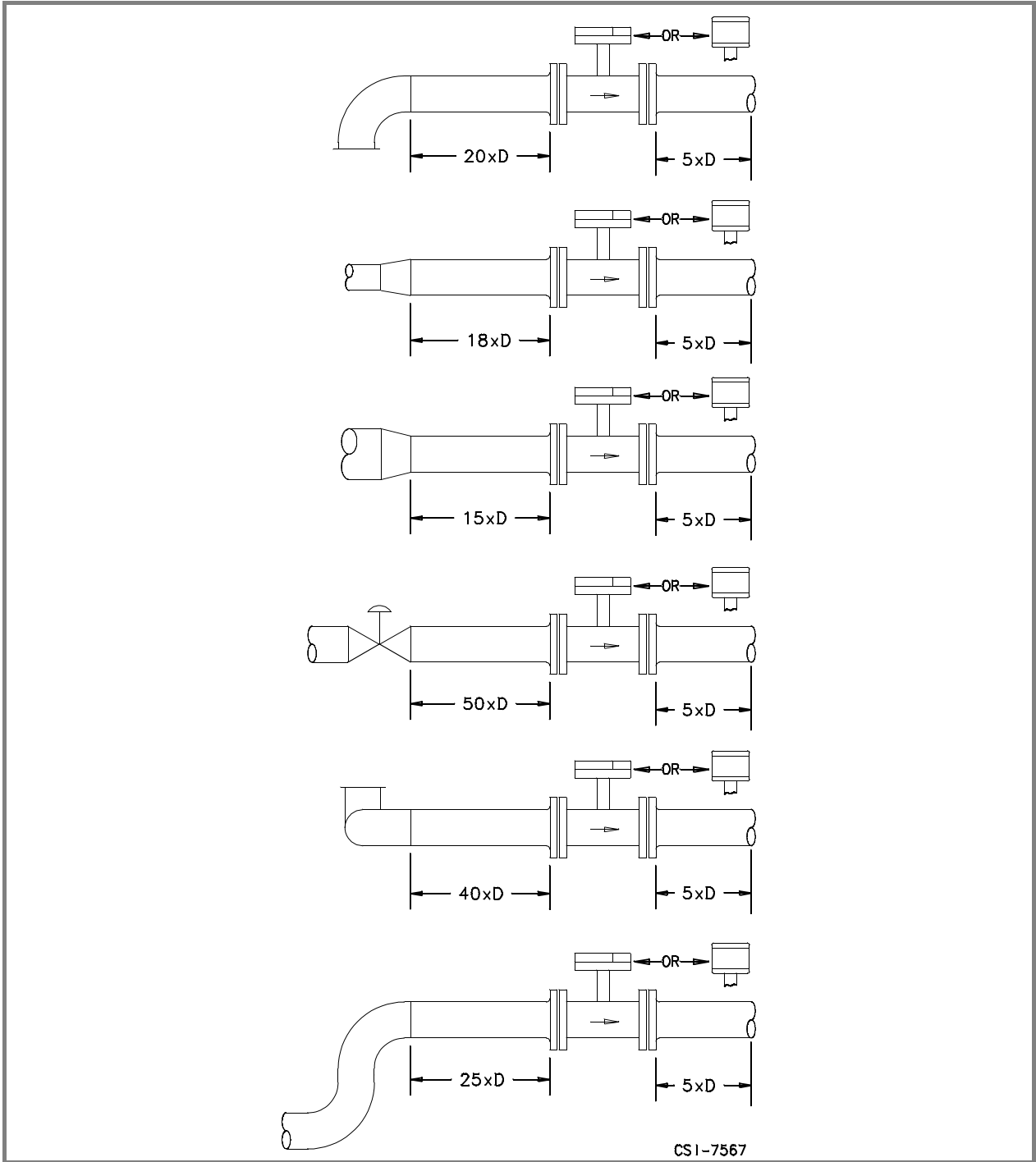

D = Meter Size

FIGURE 1-4. METER PIPING REQUIREMENTS

TABLE 1-1. AIR FLOW RATES

Meter Size		Internal Diameter	Minimum Air Flow	Maximum Air Flow		
inches	mm	inches	acfh	acfh	ft/sec	max Δ p (psi)
1	25	0.957	343	2895	161	0.70
1.5	40	1.500	742	11310	256	1.09
2	50	1.939	1519	15891	215	0.70
3	80	2.900	2649	35314	214	0.80
4	100	3.826	4238	67098	233	0.65
6	150	5.761	8829	143023	219	0.90
8	200	7.625	8829	282520	247	0.80
10	250	9.562	28248	494340	275	0.80
12	300	11.374	49434	706200	278	0.80

TABLE 1-2. GAS PRESSURE LOSS CALCULATIONS

Pressure Loss For Steam and Gas
$\Delta p_2 = \Delta p_1 \frac{\rho}{.0749} \left(\frac{Q}{Q_{max}} \right)^2$
Δp_2 = Pressure drop at operating conditions
Δp_1 = Max. pressure drop for air from Table 1-1
ρ = Operating density (lbs/ft ³)
Q = Operating flow rate (acfh)
Q_{max} = Maximum air flow rate (acfh) from Table 1-1

Conversions: kPa = 6.895 x psi
 m³/h = 0.22715 x GPM

TABLE 1- 3. WATER FLOW RATES AND FREQUENCIES

Meter Size (inches)	K-Factor (nominal)	Flow Rate Limits (a)			Vortex Frequency (Hz)	
		Minimum (GPM)	Maximum (GPM) (c)	Max. Δ p (psi)	Minimum	Maximum
1	80,000	3.6 (7.0) (b)	79	16.25	35.3	400
1.5	21,000	10.6	211	21.9	14.0	280
2	10,000	13.3	308	16.82	8.4	194.4
3	3,100	35.4	748	19.8	6.9	146.4
4	1,300	44.1	1,188	16.4	3.6	97.5
6	400	132	2,773	17.25	3.3	70
8	160	220	4,843	17.1	2.2	48.9
10	72	246	7,485	17.4	1.1	34
12	40	418	10,568	17.7	1.05	26.7

- NOTE: (a) At Standard conditions at 70° F (21° C)
 (b) Values in parentheses are minimum linear flow rates if greater than minimum operating flow rate.
 (c) Maximum flow rates based on velocity of 33 ft/sec.

TABLE 1-4. LIQUID PRESSURE LOSS CALCULATIONS

Pressure Loss For Liquid Flow	
$\Delta p_2 = \Delta p_1 (\text{Sp. gr.}) \left(\frac{Q}{Q_{\max}} \right)^2$	
Δp ₂ = Pressure drop at operating conditions	
Δp ₁ = Max. pressure drop for water from Table 1-3	
Sp. gr. = Specific gravity at operating conditions	
Q = Operating flow rate (GPM)	
Q _{max} = Maximum meter water rate from Table 1-3	

Conversions: m³/h = 0.22715 x GPM
 kPa = 6.895 x psi

Line Size (inches)	Minimum Flow Rate
1, 1.5, 2	Q _{min} = 6.329 x D x Viscosity
3, 4	Q _{min} = 11.49 x D x Viscosity
6, 8, 10, 12	Q _{min} = 22.15 x D x Viscosity

Where: Q_{min} = Minimum flow rate in GPM.
 D = Internal pipe diameter in inches (refer to Table 1-1).
 Viscosity = In centistokes.

See pg. 5-3 for additional conversion factors.

TABLE 1-5. AIR FLOW RATES AT SELECTED PRESSURES IN SCFH

METER SIZE in. (mm)	AIR FLOW	Flow Rates In Standard Cubic Feet per Hour at 70° F						
		PRESSURE (psig)						
		0	25	50	100	150	200	300
1 (25)	min.	343	564	719	958	1148	1310	1586
	max.	2895	7818	12742	22589	32436	42283	61977
1.5 (40)	min.	742	1220	1556	2072	2482	2834	3432
	max.	11310	30545	49779	88249	126718	165188	242126
2 (50)	min.	1519	2498	3185	4241	5082	5802	7025
	max.	15891	42917	69942	123993	178044	232095	340197
3 (80)	min.	2649	4356	5555	7396	8863	10119	12251
	max.	35314	95372	155430	275545	395661	515777	756008
4 (100)	min.	4238	6969	8887	11832	14179	16189	19599
	max.	67098	181210	295322	523547	751771	979996	1436445
6 (150)	min.	8829	14519	18513	24650	29539	33726	40831
	max.	143023	386259	629496	1115969	1602441	2088914	3061860
8 (200)	min.	8829	14519	18513	24650	29539	33726	40831
	max.	282520	762996	1243472	2204425	3165377	4126330	6048234
10 (250)	min.	28248	46454	59232	78867	94507	107904	130638
	max.	494340	1335054	2175769	3857197	5538626	7220054	10582911
12(300)	min.	49434	81295	103657	138018	165388	188831	228617
	max.	706200	1907220	3108241	5510282	7912322	10314363	15118445

For gases with densities other than air:

$$SCFH = ACFH \cdot \left(\frac{P}{14.7} \right) \cdot \left(\frac{530}{460 + ^\circ F} \right)$$

$$Q_{min} = ACFH_{min} (.0749/\rho)^{1/2}$$

Q_{max} is based on maximum velocity in ft/sec (Refer to Table 1-1)

where P = Operating pressure (psia)
 $ACFH_{min}$ = Refer to Table 1-1
 $ACFH_{max}$ = Refer to Table 1-1
 ρ = Density of fluid at operating conditions (lbs/ft³)
 .0749 = Density of air @ 14.7 psia & 70° F

SATURATED STEAM FLOW IN POUNDS PER HOUR																		
Meter Size →	1 in.		1.5 in.		2 in.		3 in.		4 in.		6 in.		8 in.		10 in.		12 in.	
	min.	max.	min.	max.	min.	max.	min.	max.	min.	max.	min.	max.	min.	max.	min.	max.	min.	max.
Pressure (psi)																		
15	25	211	55	826	112	1160	196	2578	313	4898	653	10441	819	20624	2089	36087	3655	51553
30	31	307	66	1129	135	1684	236	3743	378	7112	787	15160	1189	29947	2517	52400	4405	74857
60	39	498	84	1945	172	2733	301	6074	481	11541	1102	24600	1930	48593	3206	85026	5611	121466
100	48	744	103	2907	211	4084	368	9076	588	17244	1646	36757	2884	72608	4535	127045	6859	181493
125	52	903	113	3529	232	4958	405	11018	648	20935	1999	44623	3501	88146	5506	154234	7790	220334
150	56	1048	122	4094	250	5753	436	12784	698	24289	2319	51744	4062	102272	6388	178951	9038	255644
200	64	1349	139	5270	284	7405	506	16456	880	31268	2985	66649	5229	131654	8223	230362	11635	329089
225	68	1508	151	5893	300	8279	565	18399	984	34958	3337	74515	5846	147193	9194	257551	13008	367930
250	71	1662	167	6492	315	9121	623	20270	1084	38514	3677	82095	6441	162166	10129	283751	14332	405359
300	80	1969	197	7691	343	10806	738	24014	1284	45627	4356	97256	7630	192114	12000	336151	16978	480216
400	105	2582	259	10089	433	14175	968	31500	1684	59851	5714	127577	10009	252008	15741	440951	22271	629930

For other steam densities: the greater of $Q_{\min} \text{ (PPH)} = \text{ACFH}_{\min} \cdot (.0749/\rho)^{1/2} \cdot \rho$ or $Q_{\min} \text{ (PPH)} = 129 \cdot D^2 \cdot \rho$ for ≤ 4 " sizes
 $Q_{\min} \text{ (PPH)} = 193 \cdot D^2 \cdot \rho$ for ≥ 6 " sizes

$$Q_{\max} \text{ (PPH)} = \text{ACFH}_{\max} \cdot \rho$$

where: ACFH_{\min} & ACFH_{\max} refer to values from Table 1-1
 ρ = fluid Density at operating conditions in lbs/ft^3
 $.0749$ = Density of air @ 14.7 psia & 70o F
 D = Internal pipe diameter in inches

TABLE 1-6. SATURATED STEAM FLOW RATES

2.0 INSTALLATION

2.1 Inspection

All equipment should be inspected for damage that may have occurred during shipment. All damage should be reported to the shipping agent. If the equipment is damaged to the extent that faulty operation may result, contact Bailey-Fischer & Porter before installation. Always reference the complete instrument serial number and model number in all correspondence concerning the equipment supplied.

2.2 Location and Mounting

2.2.1 Flowmeter

The meter can be installed at any angle and is available in a flange style body that mounts between adjacent pipe flanges of the process piping. Since the meter is unidirectional, it must be oriented in accordance with the direction of the process flow. A flow direction arrow is provided on the meter body to assure correct orientation.

Strainers and flow straighteners are not required. Refer to Figure 1-4 for meter piping requirements.

Assuming a properly supported pipeline, vibration problems should not be encountered in normal industrial applications.

The inside diameter of the flowmeter is the same as Schedule 80 pipe. The flowmeter K-factor is based on testing with Schedule 40 pipe. Refer to Table 1-1.

In vertical and sloping installations, the electrical conduit entries should face downward to retard the entry of condensation. In horizontal installations, when process temperatures above 160° F (71° C) or below 0° F (-18° C) are encountered, the meter must be oriented so that the junction box is located to the side of the meter body, not above or below.

CAUTION

The pipeline and meter body may be insulated by the user. However, the meter interconnection wiring box and sensor housing tower must not be insulated. Ambient air is required to dissipate heat or cold build-up within the interconnection wiring box.

The meter includes a pressure relief feature described in Sub-Section 2.8. Take the location of this pressure relief into consideration when locating and orienting your meter.

2.2.2 Signal Converter

Refer to Figure 2-10 for outline dimensions of the signal converter.

Conduit seals are required at all cable entrances. The signal converter enclosure is designed to meet NEMA 4X standards and is suitable for indoor or outdoor installation in an environment that is within the temperature and humidity limits as given in Section 1.4. The enclosure should be mounted in a vertical position with the 1/2 inch NPT conduit openings on the bottom. All unused conduit entrances must have pipe plugs installed. This is required to maintain the NEMA 4X rating.

Mounting hardware for wall mounting is supplied by the user.

An alternative mounting option permits the enclosure housing to be mounted to a 2 inch horizontal or vertical pipe. The pipe clamping brackets and mounting hardware are supplied by Bailey-Fischer & Porter. Insert the two 5/16-18 x 3-3/4 inch bolts into the holes provided in the pipe mounting bracket. Orient the bracket as required for vertical or horizontal pipe. As shown in Figure 2-10, this pipe mounting bracket must be attached to the rear of the enclosure. Four 1/4-20 x 1/2 inch self-tapping screws are supplied with the pipe mounting kit for attaching the bracket. To mount the enclosure, place the housing with the attached bracket against the mounting pipe with the pipe between the two 3-3/4 inch bolts. While supporting the housing, install the pipe clamping bracket, flat washers and hex nuts. Tighten the nuts alternately to maintain even pressure distribution across the clamping bracket. Check that the enclosure housing is plumb before securing.

2.2.3 Extreme Temperature Applications

For process temperatures above 160° F (71° C) or below 0° F (-18° C), it is critical that the meter be pressurized and placed into service gradually, i.e., with sufficient time delay to minimize thermal shock. Steam should be introduced gradually so that the meter is brought up to operating temperature over a ten to fifteen minute period.

WARNING

When the meter is used in a very high or low temperature process, the temperature of the meter body may be extremely hot or cold. If it is necessary to touch the sensor housing or meter body, insulated gloves must be worn to prevent serious injury.

2.3 Temperature/Pressure Monitoring

Provisions for temperature and/or pressure monitoring are the responsibility of the user. The temperature sensor should be located five to eight pipe diameters downstream of the flowmeter. The pressure tap should be located three to five pipe diameters downstream of the flowmeter. Measurement is from the downstream face of the meter.

2.4 Meter Weights

The weights shown in the following table are approximate and should only be used as a guide when installing the meter.

TABLE 2-1. VORTEX FLOWMETER WEIGHTS

Meter Size		Flange Class 150	Flange Class 300	Wafer
inch	mm			
1	25	16 lbs (7.3 kg)	17 lbs (7.7 kg)	-----
1.5	40	18 lbs (8.1 kg)	22 lbs (10 kg)	16 lbs (7.3 kg)
2	50	22 lbs (10 kg)	26 lbs (11.8 kg)	18 lbs (8.2 kg)
3	80	31 lbs (14.1 kg)	39 lbs (17.7 kg)	23 lbs (10.4 kg)
4	100	37 lbs (16.8 kg)	46 lbs (20.9 kg)	28 lbs (12.7 kg)
6	150	58 lbs (26.3 kg)	75 lbs (34 kg)	45 lbs (20.4 kg)
8	200	70 lbs (31.8 kg)	88 lbs (39.9 kg)	61 lbs (27.7 kg)
10	250	90 lbs (40.8 kg)	110 lbs (49.9 kg)	-----
12	300	100 lbs (45.4 kg)	125 lbs (56.7 kg)	-----

Refer to Figure 2-1 for outline dimensions of the flowmeter.

OUTLINE-DIMENSIONS inches (mm)

METER SIZE	ANSI RATING	VIEW	"A" DIA	B	C	"d" DIA	E	"F" DIA	G	H	N	BOLT CIRCLE
1.0 (25)	150	B	4-1/4 (108)	7-7/8 (200)	7-1/2 (190.5)	5/8 (15.9)	8-25/32 (223)	2 (50.8)	9/16 (14.3)	—	4	3-1/8 (79.4)
	300		4-7/8 (123.8)			3/4 (19)		11/16 (17.5)	3-1/2 (88.9)			
1.5 (40)	150	B	5 (127)	7-7/8 (200)	7-3/16 (182.5)	5/8 (15.9)	8-15/32 (215.1)	2-7/8 (73)	11/16 (17.5)	—	4	3-7/8 (98.4)
	300		6-1/8 (155.6)			7/8 (22.2)		13/16 (20.6)	4-1/2 (114.3)			
	150/300	A	3-3/8 (85.7)	4-7/16 (112.7)	6-15/16 (176.2)	—	8-7/32 (208.8)	3-1/4 (82.6)	—	9/64 (3.6)	—	—
2 (50)	150	B	6 (152.4)	7-7/8 (200)	7-1/2 (190.5)	3/4 (19)	8-25/32 (223)	3-5/8 (92)	3/4 (19)	—	4	4-3/4 (120.7)
	300		6-1/2 (165.1)			7/8 (22.2)		7/8 (22.2)	5 (127)			
	150/300	A	3-7/8 (98.4)	4-7/16 (112.7)	7-3/16 (182.5)	—	8-15/32 (215.1)	3-23/32 (94.5)	—	5/32 (4)	—	—
3 (80)	150	B	7-1/2 (190.5)	7-7/8 (200)	8-1/4 (209.5)	3/4 (19)	9-17/32 (242.1)	5 (127)	15/16 (23.8)	—	4	6 (152.4)
	300		8-1/4 (209.6)			7/8 (22.2)		1-1/8 (31.8)	6-5/8 (168.3)			
	150/300	A	5-3/8 (136.5)	4-3/8 (111.1)	7-5/8 (193.7)	—	8-31/32 (227.8)	—	—	—	—	—
4 (100)	150	B	9 (228.6)	9-27/32 (250)	8-9/16 (217.4)	3/4 (19)	9-7/8 (250.8)	6-3/16 (157.2)	15/16 (23.8)	—	8	7-1/2 (190.5)
	300		10 (254)			7/8 (22.2)		1-1/4 (31.8)	7-7/8 (200)			
	150/300	A	6-3/8 (161.9)	4-9/16 (115.9)	8-3/16 (207.9)	—	9-15/32 (240.5)	—	—	—	—	—
6 (150)	150	B	11 (279.4)	11-13/16 (300)	9-5/8 (244.4)	7/8 (22.2)	10-15/16 (277.8)	8-1/2 (215.9)	1 (25.4)	—	8	9-1/2 (241)
	300		12-1/2 (317.5)			9-1/4 (234.9)		10-17/32 (267.5)	1-7/16 (36.5)			10-5/8 (269.9)
	150/300	A	8-1/2 (215.9)	5-3/8 (136.5)	9-1/4 (234.9)	—	10-17/32 (267.5)	—	—	—	—	—
8 (200)	150	B	13-1/2 (342.9)	13-3/4 (350)	10-1/2 (266.9)	7/8 (22.2)	11-3/4 (298.7)	10-5/8 (269.9)	1-1/8 (28.6)	—	8	11-3/4 (298.5)
	300		15 (381)			1 (25.4)		1-5/8 (41.3)	13 (330.2)			
	150/300	A	10-5/8 (269.9)	6-1/4 (158.8)	10-3/16 (258.8)	—	11-15/32 (291.3)	—	—	—	—	—
10.0 (250)	150	B	16 (406.4)	17.7 (450)	14 (353)	1 (25.4)	13.3 (353)	12.75 (323.90)	1.2 (30.2)	—	12	14.25 (365)
	300		17.5 (444.5)			1.1 (28.4)		1.85 (47.7)	15.25 (387.3)			
12.0 (300)	150	B	19 (482.6)	19.75 (500)	15 (379)	1 (25.4)	14.3 (364)	15 (381)	1.25 (31.8)	—	12	17 (431.8)
	300		20.5 (520.7)			1.25 (31.7)		2 (50.8)	17.75 (450.8)			

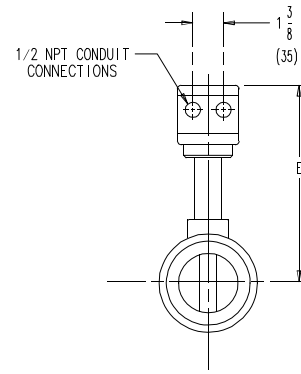

WAFER VIEW A

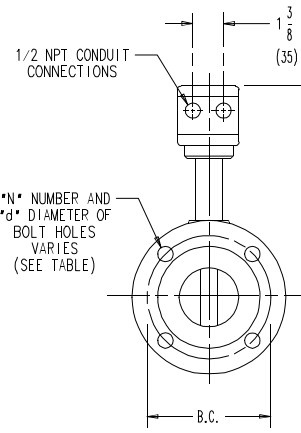
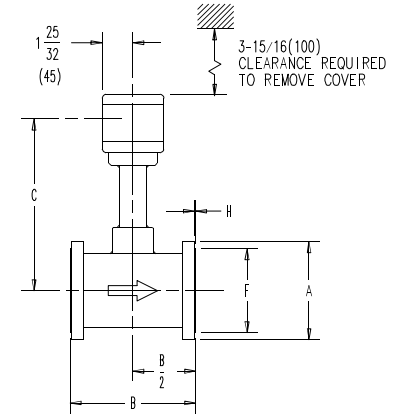

FLANGE VIEW B

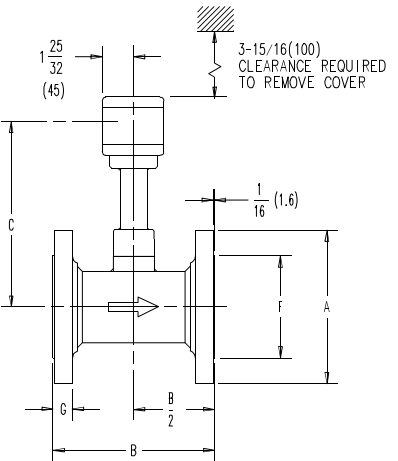

N NUMBER AND "d" DIAMETER OF BOLT HOLES VARIES (SEE TABLE)

(REF 00-10L-1029 REV.1)

- NOTES:
1. ALL DIMENSIONS ARE IN INCHES. DIMENSIONS IN PARENTHESIS () ARE IN (mm).
 2. ALL DIMENSIONS ARE GUARANTEED ONLY IF THIS PRINT IS CERTIFIED.
 3. THIS DRAWING IS A THIRD ANGLE PROJECTION AS SHOWN.
 4. FLANGE BOLT HOLES STRADDLE CENTERLINES.

FIGURE 2-1. VORTEX FLOWMETER OUTLINE DIMENSIONS

2.5 Wafer Meter Installation

The wafer style meter body mounts inside the pipe flange bolt circle. To assure optimum meter performance, the meter should be installed in accordance with the upstream and downstream straight run piping requirements given in Figure 1-4. The straight run piping should be schedule 80 or lighter pipe. Either flat or raised face flanges may be used.

Remove the shipping covers used to protect the meter inlet and outlet surfaces from damage during transit and handling.

2.5.1 Wafer Style Sizes 1.5 and 2 inches

Optional centering rings, mounting studs and nuts are supplied when specified at time of order. The centering rings have an internal diameter that permits the ring to be mounted via an undercut face on the inlet and outlet ends of the meter body. Regardless of whether the meter will be installed in a horizontal, sloping, or vertical pipeline, one ring is used at the inlet end and the other ring at the outlet end of the meter. Use of the centering rings is illustrated in Figure 2-2. The rings will have several bolt alignment hole patterns that are spaced and located on different bolt circle radii. This permits the centering ring for a particular meter size to be adapted for various flange ratings, e.g., ANSI Class 150 or 300 flanges. When installing the centering rings, orient them so that the flange rating values stamped on the rings will face the meter body, i.e., markings must be visible. Position the centering ring so that the mounting studs will pass through the appropriate set of bolt circle radii, as designated according to the flange rating.

Place the flange gaskets (two supplied) against the upstream and downstream flange faces. Align the gaskets holes with the flange bolt pattern. When installing the flange gaskets, use care to assure that the gaskets fit properly and do not project into the pipe line causing an alteration of the flow profile. A change in flow profile can adversely affect meter accuracy.

Install the meter in the pipeline, between the inlet and outlet gaskets. Make certain that the **flow direction arrow** on the meter body is oriented in accordance with the process flow. If the meter is installed in a horizontal pipeline, insert two studs in the bottom two flange holes to support the meter. When installing the meter in a vertical pipe run, some temporary support may be required until mounting studs and nuts have been installed.

Install the remaining mounting studs, as required. Studs and nuts should be lubricated with a graphite based lubricant. Assemble a nut on each end of the mounting studs hand tight. Tighten the stud nuts in a diagonally opposite pattern, as shown in Figure 2-4, to equalize pressure on the meter face. Nut torque should be limited to that which will provide a leakproof seal.

2.5.2 Wafer Style Sizes 3 through 8 inches

Place the flange gaskets (two supplied) against the upstream and downstream flange faces. Align the gaskets holes with the flange bolt pattern. When installing the flange gaskets, use care to assure that the gaskets fit properly and do not project into the pipe line causing an alteration of the flow profile. A change in flow profile can adversely affect meter accuracy.

Optional centering sleeves (spacers), mounting studs and nuts are supplied when specified at time of order.

Placement of the sleeves is dependent on the type of installation (vertical/horizontal/sloping). If the meter is installed in a vertical pipeline, select four equally spaced bolt holes for placement of the four sleeves and studs (refer to Figure 2-3). If the meter is installed in a horizontal or sloping pipeline,

select the bottom two holes of the flanges on each end of the meter for placement of the four sleeves and studs.

Install the meter in the pipeline between the inlet and outlet gaskets. Make certain that the **flow direction arrow** on the meter body is oriented in accordance with the process flow. In horizontal pipe runs the meter will be supported by the upstream and downstream sleeves. When installing the meter in a vertical pipe run, some temporary support may be required until mounting studs and nuts have been installed.

Install the remaining mounting studs, as required. Studs and nuts should be lubricated with a graphite based lubricant. Place a hex nut on each end of the mounting stud. Tighten the stud nuts in a diagonally opposite pattern, as shown in Figure 2-4, to equalize pressure on the meter face. Nut torque should be limited to that which will provide a leakproof seal.

NOTES:

1. UNLESS OTHERWISE SPECIFIED, ALL MOUNTING HARDWARE AND GASKETS SUPPLIED BY F & P.
2. METER RATED FOR 720 psi (4.96 mpa) MAXIMUM WORKING PRESSURE.

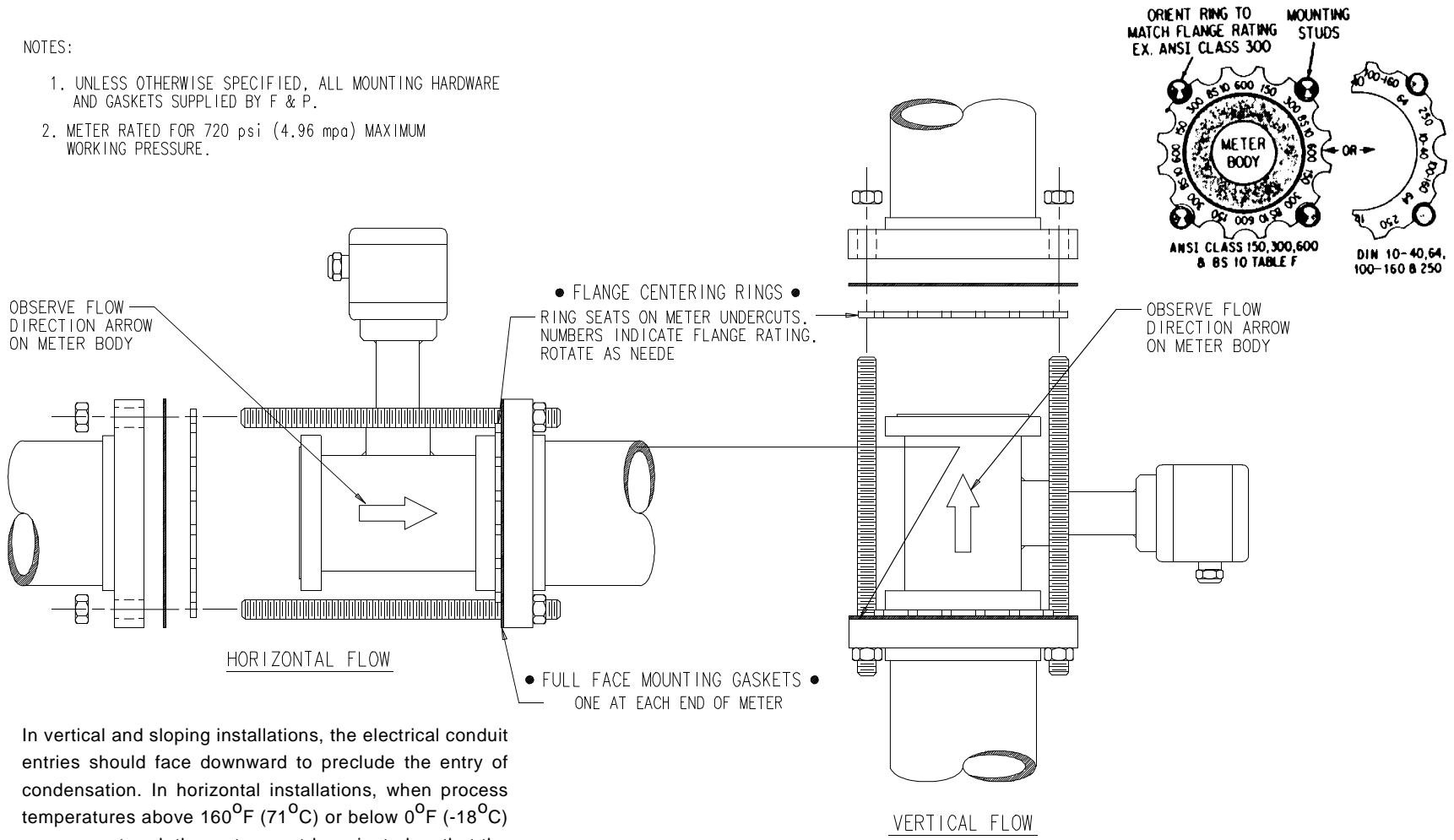

In vertical and sloping installations, the electrical conduit entries should face downward to preclude the entry of condensation. In horizontal installations, when process temperatures above 160°F (71°C) or below 0°F (-18°C) are encountered, the meter must be oriented so that the junction box is located to the side of the meter body, not above or below.

CS1-7383

FIGURE 2-2. WAFER PROCESS CONNECTIONS, SIZES 1.5 AND 2 INCHES

NOTES:

1. UNLESS OTHERWISE SPECIFIED, ALL MOUNTING HARDWARE AND GASKETS SUPPLIED BY F & P.

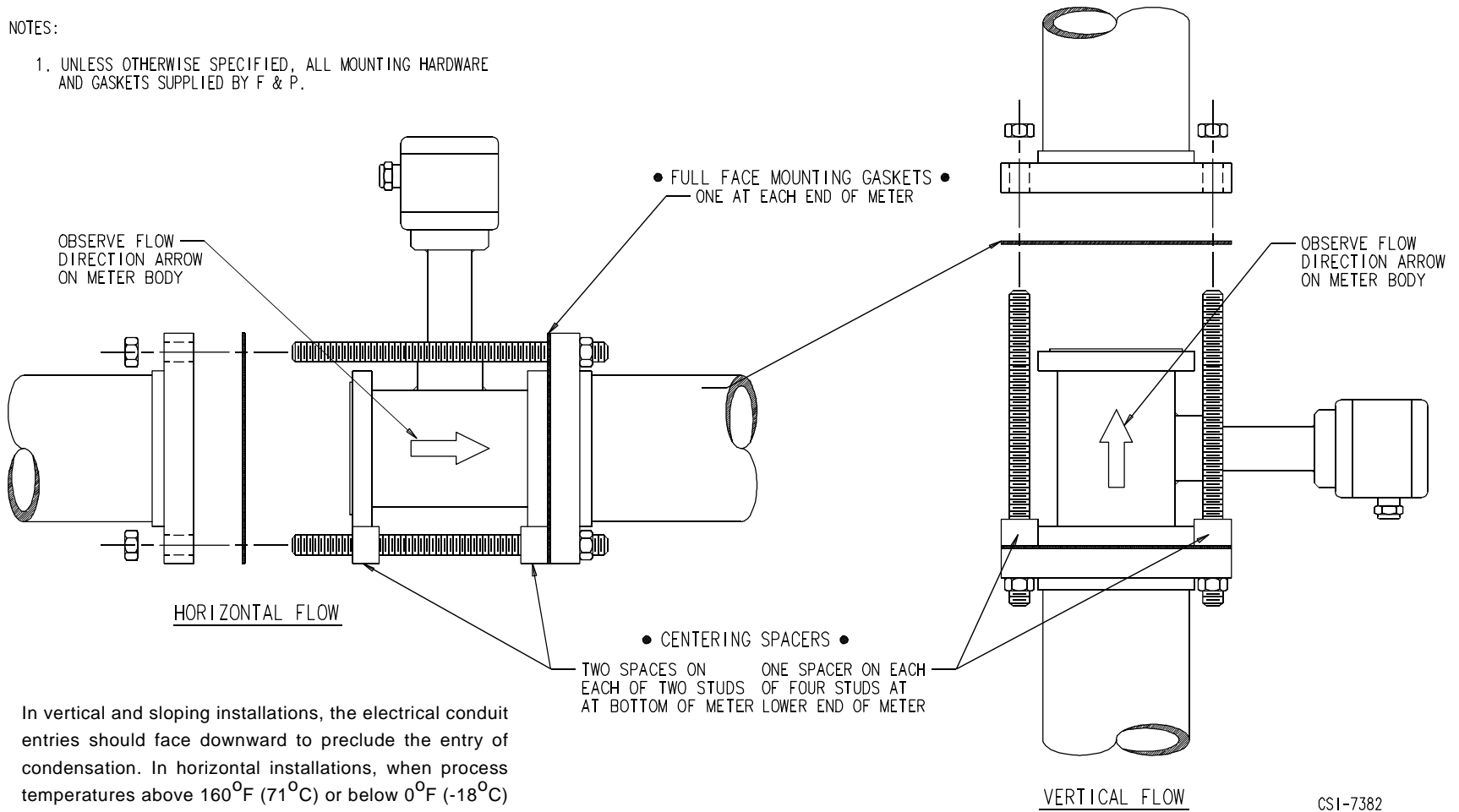

In vertical and sloping installations, the electrical conduit entries should face downward to preclude the entry of condensation. In horizontal installations, when process temperatures above 160°F (71°C) or below 0°F (-18°C) are encountered, the meter must be oriented so that the junction box is located to the side of the meter body, not above or below.

CSI-7382

FIGURE 2-3. WAFER PROCESS CONNECTIONS, SIZES 3 THROUGH 8 INCHES

2.6 Flanged Meter Installation

To assure optimum meter performance, the meter should be installed in accordance with the upstream and downstream straight run piping requirements shown in Figure 1-4. The straight run piping should be schedule 80 or lighter pipe. Process flanges should be raised face.

Remove the covers used to protect the meter inlet and outlet surfaces from damage during shipment.

Place the two supplied flange gaskets against the upstream and downstream flange faces. Align the gaskets holes with the flange hole pattern. When installing the flange gaskets, make sure that the gaskets fit properly and are aligned properly so that they don't project into the pipe line causing an alteration of the flow profile. A change in flow profile can adversely affect meter accuracy.

Mounting bolts and nuts are supplied by the user. During installation, make certain that the **flow direction arrow** on the meter body is oriented in accordance with the process flow.

With the meter safely supported, install the bolts through the meter and process flanges. Bolts and nuts should be lubricated with a graphite based lubricant. Assemble the nuts to the bolts hand tight. Tighten the flange nuts in a diagonal or "star" pattern as shown in Figure 2-4 to equalize pressure on the flange face and gaskets. Bolt/nut torque should be limited to that which will provide a leakproof seal.

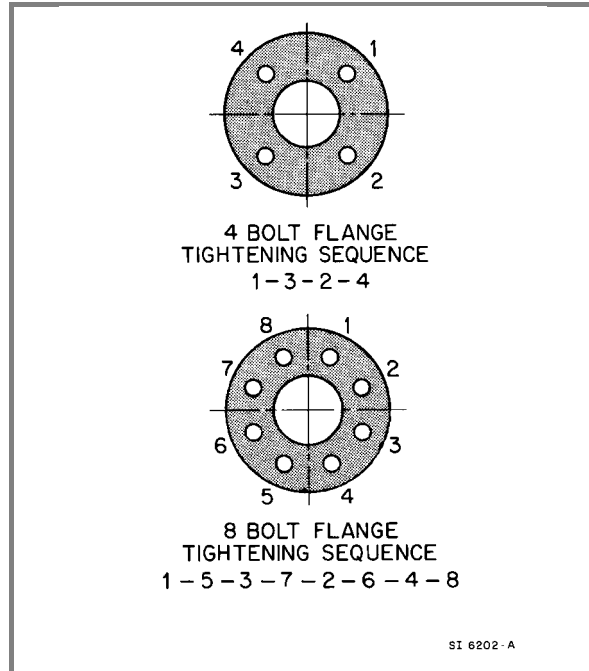

FIGURE 2-4. FLANGE BOLT TIGHTENING SEQUENCE

When correctly installed, the installation should look like that shown in Figure 2-5.

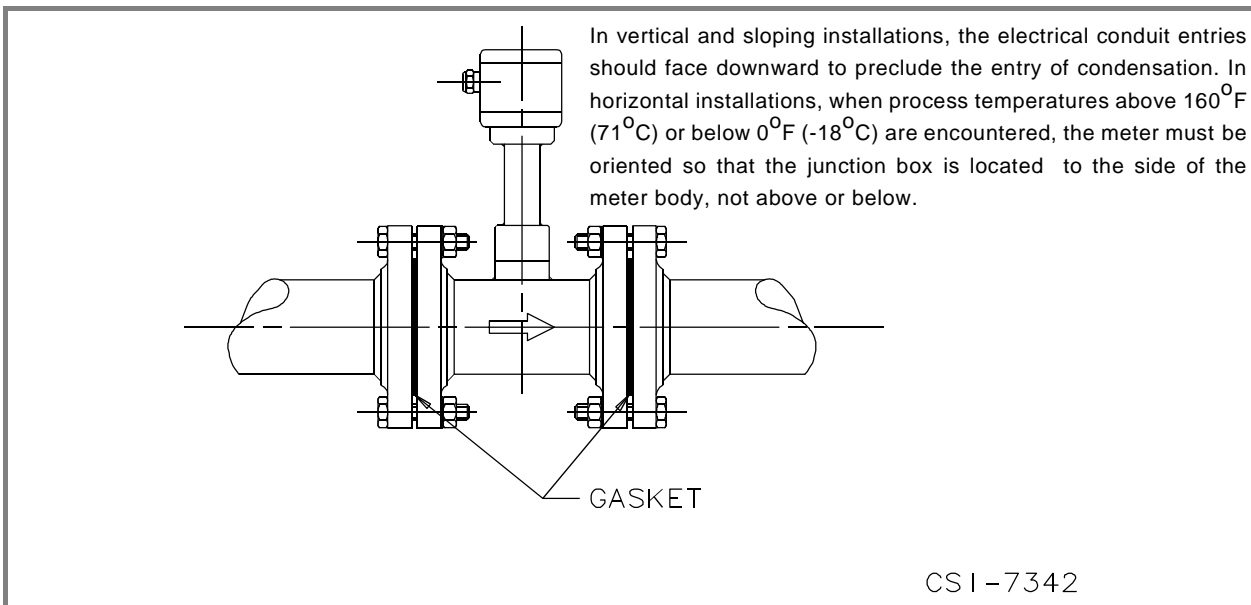

FIGURE 2-5. FLANGE PROCESS CONNECTIONS

2.7 Electrical Interconnections

The Model VR Vortex flowmeter is provided with a 15 foot (5 m) shielded interconnect cable for interconnecting the Primary and Converter. Up to a 30 foot (10 m) length is possible if the cable is rigidly supported inside electrical conduit.

The electronics housing at the Primary contains an interconnect circuit board assembly which contains the terminal blocks to attach the interconnect cable. The circuit board assembly is basically an interconnection board connecting terminals from one terminal block to the other. One terminal block is used to connect the sensor output leads while the other is used to terminate one end of the interconnect cable. The layout of this Primary circuit board assembly is shown in Figure 2-6. Since there is no pre-amplification circuitry, the interconnect cable is essentially an extension of the sensor's signal leads and any flexing or other movement is detrimental to the quality of the sensed flow signal. It is therefore strongly recommended that the interconnect cable be firmly supported for optimum operation.

CAUTION
All unused conduit entrances must have pipe plugs installed. This is required to maintain the NEMA 4X enclosure rating.

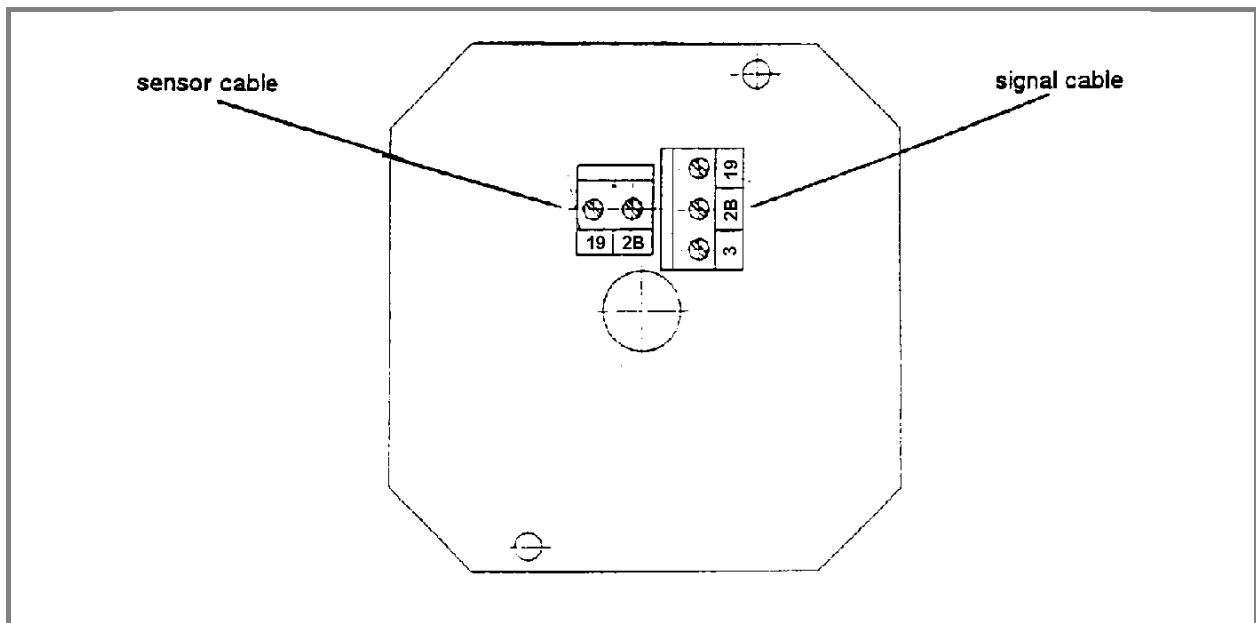

FIGURE 2-6. PRIMARY CONNECTION BOARD LAYOUT

The other end of the interconnect cable attaches to terminal block 1x3 on the Connection Board shown in Figure 2-7. Sensor signals on terminals 2B & 19 from terminal block 1x3 are routed, via feedthrus, to terminal block 3x5 terminals 2B & 19 on the Analog Board assembly shown in Figure 2-8. This board assembly is located in the Converter housing in the larger of the converter's two compartments while the Connection Board is in the smaller compartment. In addition to the interface cable connections, the Converter connection board has terminals to connect the Converter's power supply connections. These are labeled **TW+** and **TW-** for the positive and negative inputs respectively. The installation site must be provided with a source of power that is compatible with the Signal Converter power requirements. Refer to the instrument tag for power requirements.

For reference purposes Figures 2-11 and 2-12 show the external interconnections schematically.

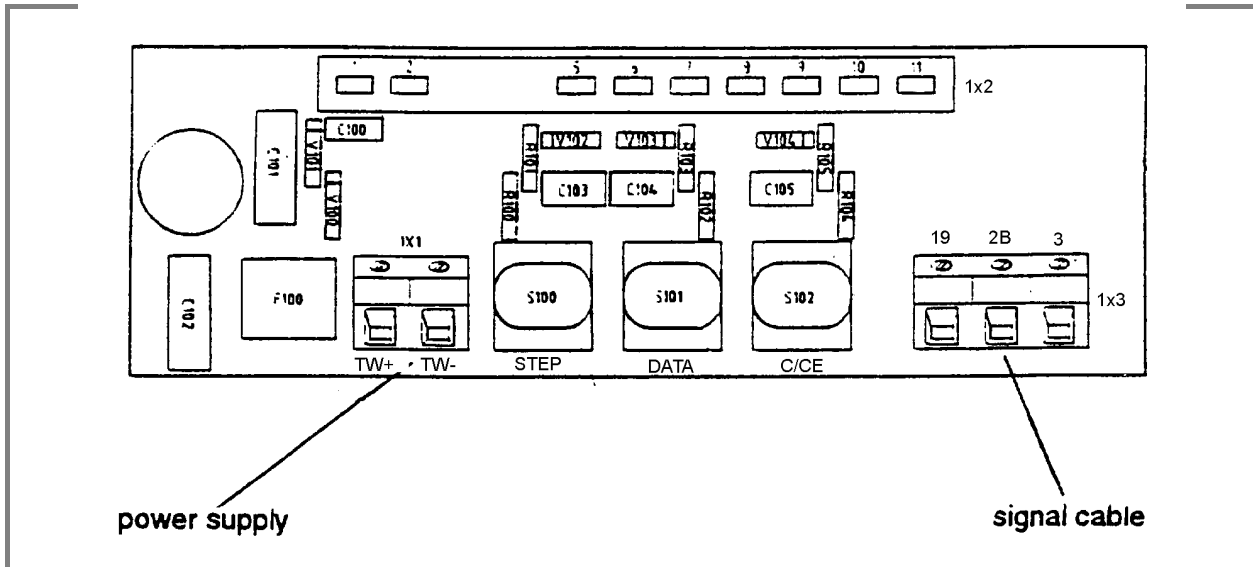

FIGURE 2-7. CONVERTER CONNECTION BOARD LAYOUT

The flowmeter housing covers are removable and may be removed for access during installation and maintenance. Remove the covers from the housing by loosening the screws on the covers. Replace the covers when the installation has been completed and **before** power is applied to the equipment.

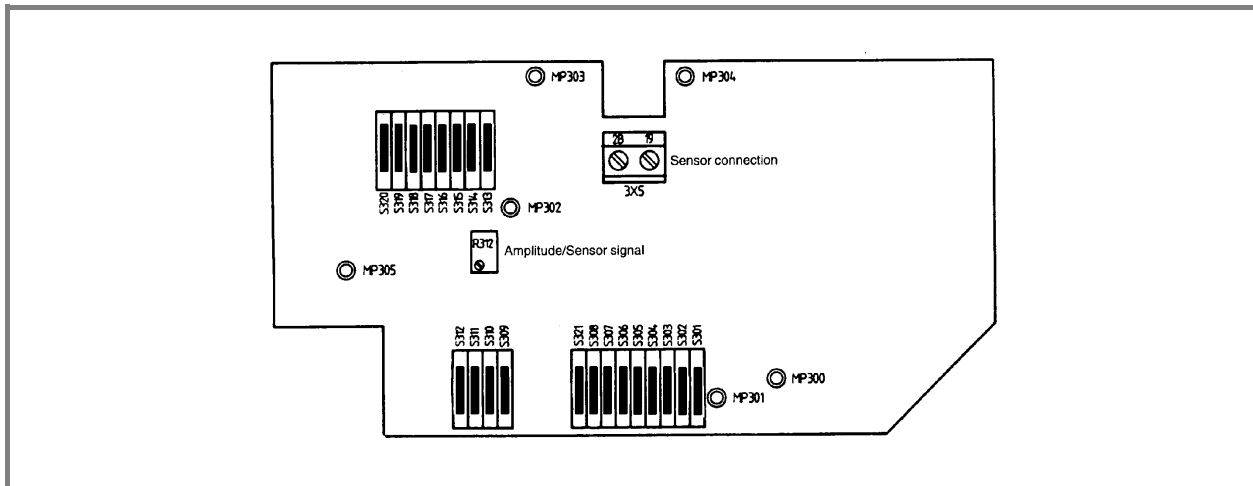

FIGURE 2-8. CONVERTER ANALOG BOARD LAYOUT

Make certain that covers are replaced properly after maintenance by using the following procedures:

- Check that gaskets are properly seated and are not pinched or stretched.
- Check that gasket surfaces are clean and free of grease or other contaminants.
- Align covers on housing and re-install bolts.
- Tighten bolts finger tight.

Finish tightening bolts in a "star" pattern to distribute force evenly.

2.8 Conduit Seal and Pressure Relief

In accordance with the National Electrical Code (NEC) ANSI/NFPA 70, Article 501-5(f)(3), the flowmeter includes a **conduit entry seal** (located between the junction box and the electronic housing as shown in Figure 2-8) and **pressure relief valve** to prevent the process fluid from entering the electrical conduit system. These safety features consider the remote possibility of a primary seal failure between the meter body and the electronic housing.

It is the user's responsibility to properly install the conduit entry cable seal fitting supplied with the meter. This will assure proper performance of this safety feature.

A **pressure relief valve** is provided in the electronics housing for the flowmeter. The pressure relief valve is located in one of the threaded entry ports of the meter junction box next to the interconnection cable entry. If the primary seal should fail, the pressure relief will vent the process preventing an over pressurization and potentially dangerous failure of the electronics housing. It is the user's responsibility to be aware of this safety feature and to consider the unlikely event of its functioning. Based on knowledge of the process and meter application, the user should consider the use of deflectors to safely direct the vented process away from any attending personnel.

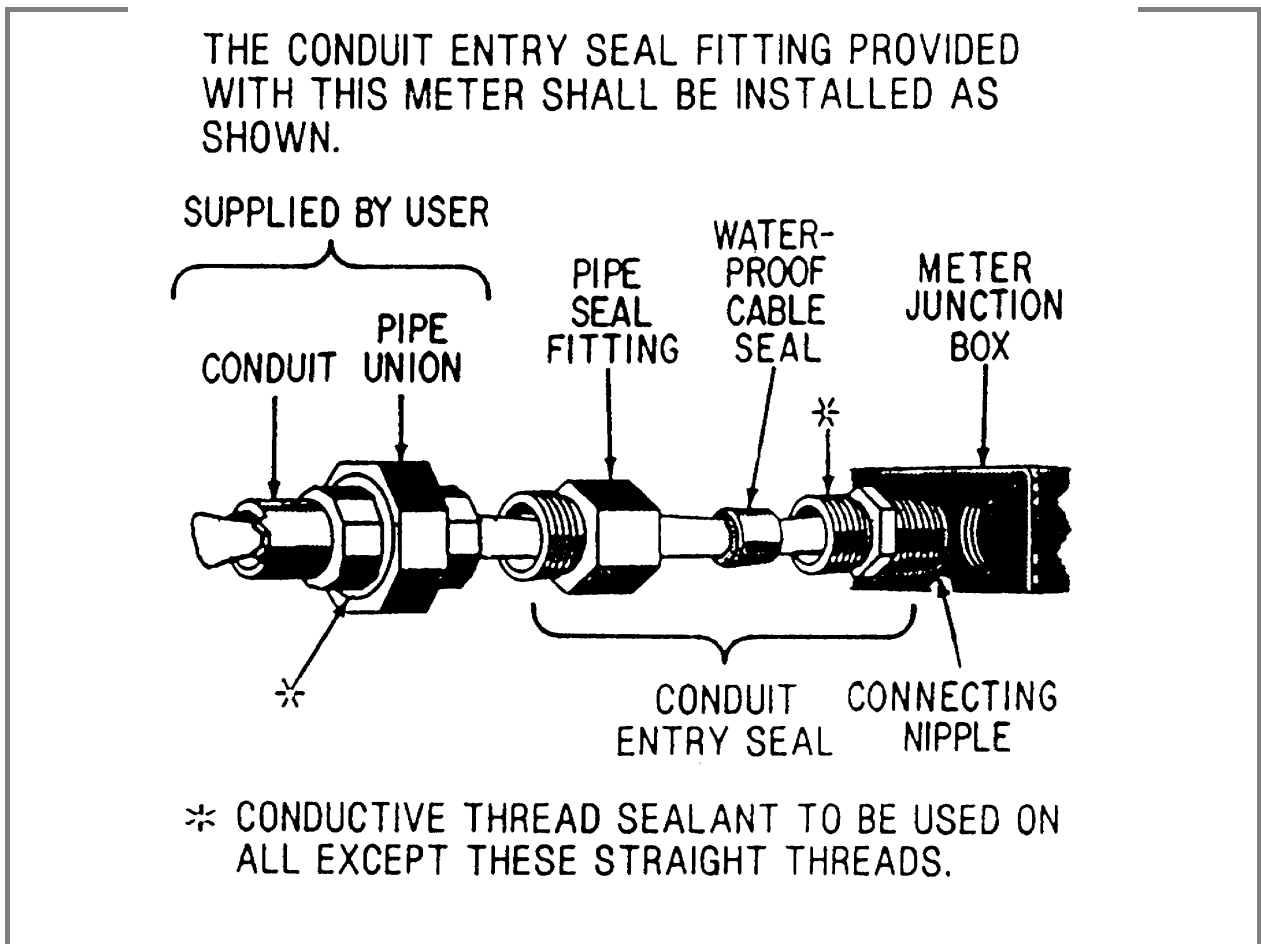
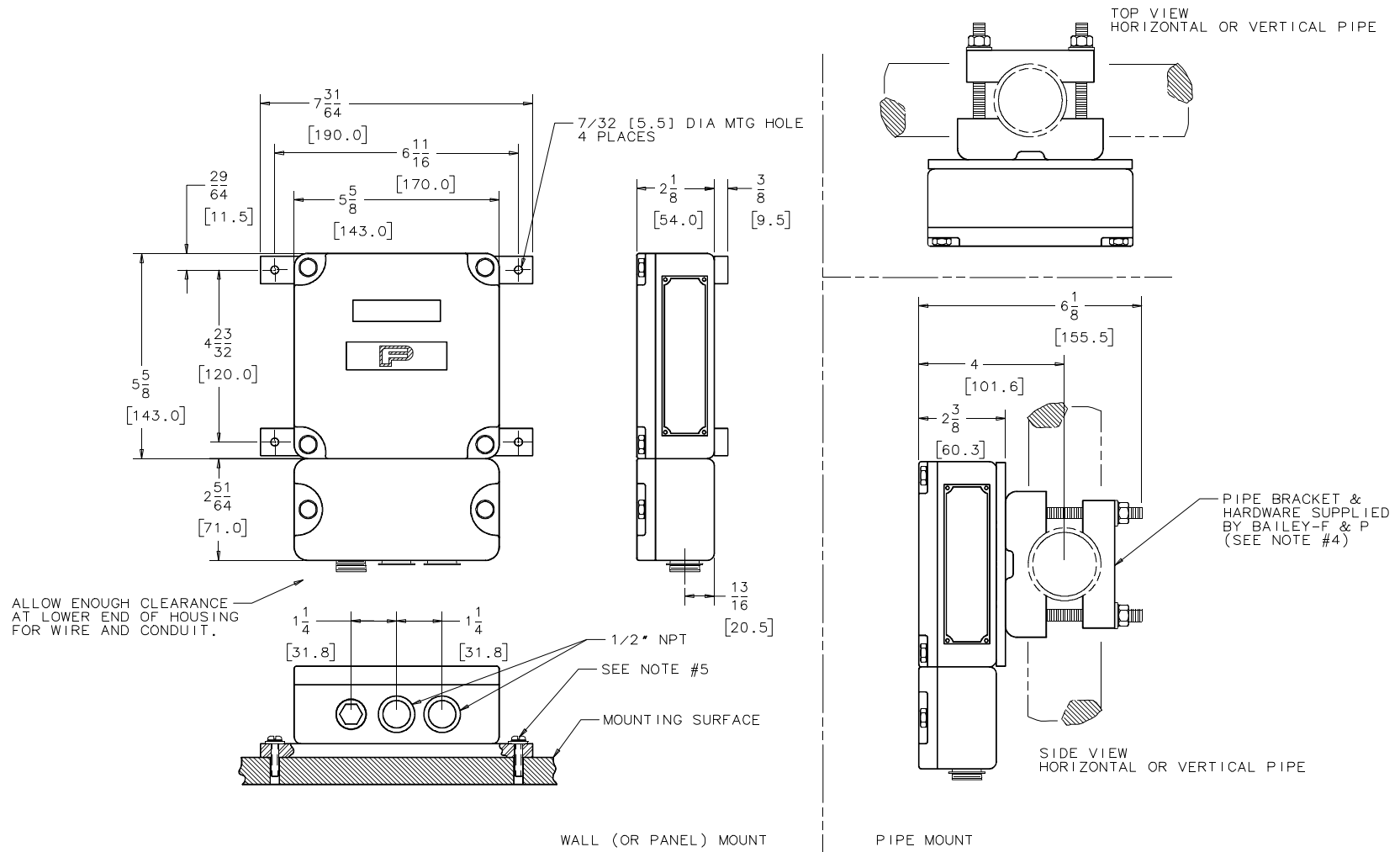

FIGURE 2-9. CONDUIT ENTRY SEAL INSTALLATION



NOTES:

1. DIMENSIONS ARE IN INCHES. DIMENSIONS IN PARENTHESES [] ARE IN MILLIMETERS.
2. DIMENSIONS GUARANTEED ONLY IF THIS PRINT IS CERTIFIED.
3. ALL DIMENSIONS SUBJECT TO MANUFACTURING TOLERANCE OF $\pm 1/8$ [3mm].
4. FOR PIPE MOUNTING, PIPE YOKE BRACKET FOR CONNECTION TO CUSTOMERS 2" [50mm] HORIZONTAL OR VERTICAL PIPE AS SHOWN.
5. MOUNTING HARDWARE SUPPLIED BY CUSTOMER.

(REF 0D-50-1284 REV 1)

FIGURE 2-10. SIGNAL CONVERTER MOUNTING & OUTLINE DIMENSIONS

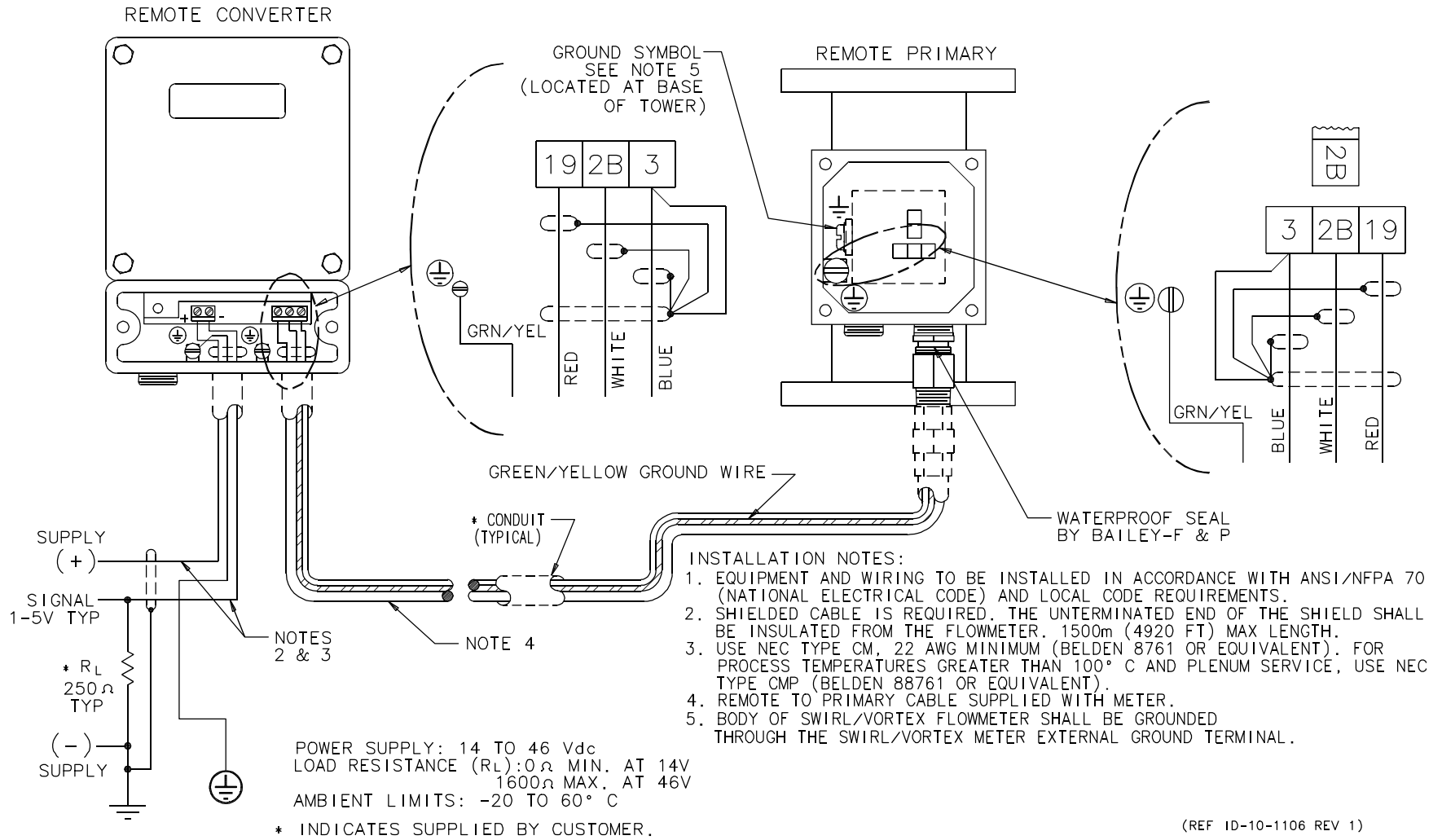

FIGURE 2-11. INTERCONNECTION WIRING DIAGRAM FOR NON-HAZARDOUS LOCATIONS

NON-HAZARDOUS LOCATION

ASSOCIATED APPARATUS

INSTALLATION TO BE IN ACCORDANCE WITH ARTICLE 504 OF ANSI/NFPA 70 (NATIONAL ELECTRICAL CODE) AND ANSI/ISA RP 12.6. BARRIER GROUND BUS MUST BE CONNECTED TO A SUITABLE GROUND ELECTRODE PER ANSI/NFPA 70, ARTICLE 504. THE RESISTANCE OF THE GROUND PATH MUST BE LESS THAN 1 OHM.

ASSOCIATED APPARATUS MAY BE LOCATED IN A DIVISION 2 LOCATION IF SO APPROVED. WIRING IN A DIVISION 2 SHALL BE PER NEC ARTICLE 501-4, NEC TYPE PLTC (BELDEN 1033A OR EQUIVALENT).

THE ASSOCIATED APPARATUS CONTROL DRAWING SHALL VERIFY COMPLIANCE WITH THE FOLLOWING SPECIFICATIONS:

ENTITY INSTALLATION REQUIREMENTS:

$$V_{max} \geq V_{dc} \text{ OR } V_l$$

$$I_{max} \geq I_{sc} \text{ OR } I_l$$

$$C_0 \geq C_i + C_{cable}$$

$$L_0 \geq L_i + L_{cable}$$

THE MAXIMUM POWER DELIVERED BY THE ASSOCIATED APPARATUS MUST NOT EXCEED 1.2 W

CONTROL EQUIPMENT

UNSPECIFIED EXCEPT THAT CONTROL APPARATUS SHALL NOT BE CONNECTED TO, OR CONTAIN UNDER NORMAL OR ABNORMAL CONDITIONS, A SOURCE OF SUPPLY VOLTAGE THAT EXCEEDS 250 V rms OR 250 V dc WITH RESPECT TO EARTH GROUND.

CONTROL EQUIPMENT MAY BE LOCATED IN A DIVISION 2 LOCATION IF SO APPROVED.

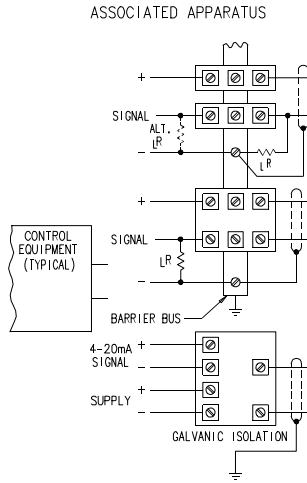

HAZARDOUS LOCATION

CLASS I, II, III, DIVISION 1, GROUPS A, B, C, D, E, F & G

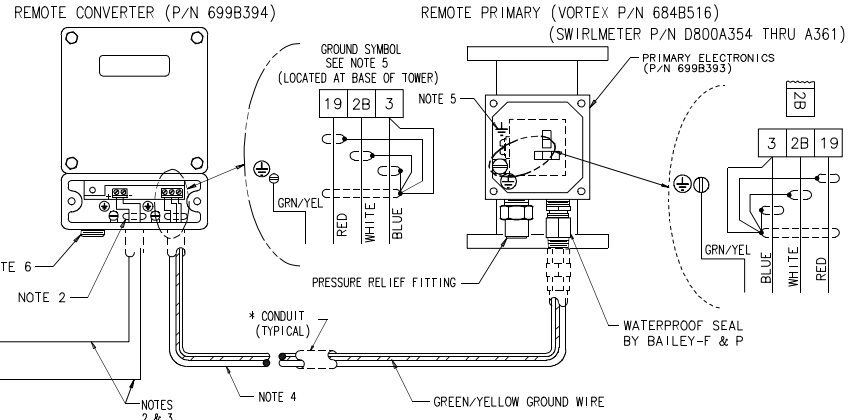

INTRINSICALLY SAFE CLASS I, II, III, DIV 1, APPLICABLE GROUPS A, B, C, D, E, F & G

APPARATUS ENTITY VALUES
 $V_{max} = 46 \text{ V}$ $I_{max} = 190 \text{ mA}$
 $C_i = 0$ $L_i = 0$
 $P_{max} = 1.2 \text{ W}$

SWIRL FLOWMETER (P/N'S 699B393, B394, AND D800A354 THRU A361) MODEL 10SR11aAbc9AdA2AAeA

- a = FLUID TYPE 1, 2, 3, 4, 5 OR 6
- b = METER SIZE B, C, D, E, F, G, H, J, K
- c = PRESSURE RATING P OR Q
- d = SENSOR 1, 5
- e = ACCESSORIES 0, 1, 2, 3

VORTEX FLOWMETER (P/N'S 699B393, B394, AND 684B516) MODEL 10VR10a1Ac1eC

- a = PROCESS CONNECTION 1 OR 3
- b = FLUID TYPE 1, 2, 3, 4, 5 OR 6
- c = METER SIZE B, C, D, E, F, G, J, K
- d = PRESSURE RATING H OR J
- e = SENSORS 1 OR 2

POWER SUPPLY: 14 TO 46V dc

LOAD RESISTANCE (R_L): 0 Ω MIN. AT 14 V
 1800 Ω MAX. AT 46 V

AMBIENT LIMITS: -4° TO 140° F (-20° TO 60° C)

REFER TO THE FLOWMETER INSTRUCTION BULLETIN FOR APPLICATION AND INSTALLATION REQUIREMENTS.

WARNING - SUBSTITUTION OF COMPONENTS MAY IMPAIR INTRINSIC SAFETY.

- INSTALLATION NOTES:**
- EQUIPMENT AND WIRING TO BE INSTALLED IN ACCORDANCE WITH ANSI/NFPA 70 (NATIONAL ELECTRICAL CODE) AND LOCAL CODE REQUIREMENTS.
 - SHIELDED CABLE IS REQUIRED. THE UNTERMINATED END OF THE SHIELD SHALL BE INSULATED FROM THE FLOWMETER. 1500m (4920 FT) MAX LENGTH.
 - USE NEC TYPE CM, 22 AWG MINIMUM (BELDEN 8761 OR EQUIVALENT). FOR PROCESS TEMPERATURES GREATER THAN 100°C AND PLENUM SERVICE, USE NEC TYPE CMP (BELDEN 88761 OR EQUIVALENT).
 - REMOTE PRIMARY CABLE SUPPLIED WITH METER.
 - BODY OF FLOWMETER SHALL BE GROUNDED THROUGH THE METER EXTERNAL GROUND TERMINAL.
 - SEALS REQUIRED AT UNUSED CONDUIT ENTRIES TO MAINTAIN NEMA 4X ENCLOSURE RATING.

* INDICATES SUPPLIED BY CUSTOMER.

(REF ID-10-1107 REV 2)

FIGURE 2-12. INTERCONNECTION WIRING DIAGRAM FOR INTRINSICALLY SAFE LOCATIONS

3.0 DATA ENTRY AND CONFIGURATION

3.1 Pushbuttons and Display

During normal operation, totalizer units and range units are shown in the display window. The display is configured as described in Sub-section 4.3.21.

Typical Display: Visible through window in electronics cover.

Flow Rate	→	Qv 50	usgpm
Total	→	Qv 5600	usgal

Pushbuttons: Located on Connection Circuit Board in signal converter interconnection junction box (Refer to Section 2.6).

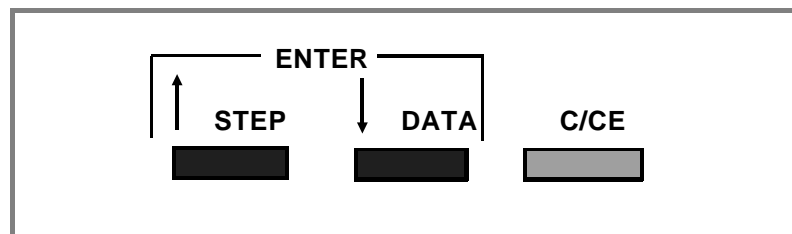

FIGURE 3-1. PROGRAMMING PUSH-BUTTONS

3.2 Pushbutton Functions

All data base interrogations and changes are made through three pushbutton switches located in the Converter's interconnection junction compartment and shown in Figures 2-6 and 3-1. They are identified as "STEP", "DATA", and "C/CE". To gain access to the data base, it is necessary to leave the normal "monitoring mode" and enter the "configuration mode". This is accomplished by pressing the pushbutton on the right which is identified as the "C/CE" pushbutton. The various parameters of the data base can then be viewed by moving up or down through the menu by pressing one of the two buttons to the left of "C/CE" identified as "STEP" and "DATA". Changes are entered by pressing the "STEP" and "DATA" pushbuttons simultaneously. This simultaneous action constitutes the "ENTER" function. If no entries or changes are made within 20 seconds the unit will automatically revert to the monitoring mode.

When the "C/CE" pushbutton is pressed, the display shows messages and database parameters instead of flow data. Pressing "C/CE" again will revert back to the monitoring mode. The first message displayed the first time the "C/CE" button is pressed after power up is "Prog. Protection ON". As long as program protection is **on**, database parameters can be displayed but not changed. In order to change parameters, program protection must be turned **off** (the procedure will be described later). The parameters may be changed using the "STEP" and "DATA" pushbuttons. To make a change take effect, use the "ENTER" function.

There are two ways to make changes to the data base: entering a **direct numeric** value and making a selection from the **menu or tabular entry**.

- **Tabular Entry** is done using the arrow keys to select a value from the menu. The selected value is entered using the "ENTER" buttons.
- **Direct Numeric Entry** is done using the "DATA" and "STEP" buttons. The "DATA" button is used to select numbers 0 through 9, decimal point, minus sign and a blank space. The "STEP" button is used to move to the next digit.

Access to the data base is gained by using the "ENTER" function. When the "ENTER" buttons are pressed, a cursor is added to the right of the data on the bottom line of the display if selection is to be made from the menu.

When the parameter to be changed is a numerical value, the top line will list the parameter name, and the bottom line will show the cursor on the left and the units on the right.

The number "0" over the cursor will now increase by one each time the "DATA" button is pressed. If it is pressed when the number nine (9) is over the cursor a decimal point (.) will appear. If it is pressed again a minus sign (-) will appear, and if it is pressed again a space will appear ().

The number can only be increased. If the required number is passed it is not possible to back up. The number must be advanced until the required value appears again. When the number appears above the cursor, press the "STEP" button once and the cursor will move one space to the right. A zero will again appear over the cursor, and the next digit can be selected. If an error is made in the selection of a number it can be corrected by pressing the "C/CE" button. The entry will be cleared, and a new entry can be made.

When the required value is reached, press the "ENTER" buttons and the value will be entered into memory. It will then be evaluated by the computer, and if it is not compatible with other selected parameters it will be rejected. An ERROR message will appear to indicate that the entry is not acceptable.

The operation of the display and the differences between the two data entry methods described above is shown summarized graphically in Section 3.3

Section 3.4 shows the menu and sub-menu structure of the converter. The sequence of progression shown assumes advancing is done using the "STEP" button after pressing "C/CE" to enter the "**configuration mode**".

3.3 Instructions For Entering Data Into the Converter

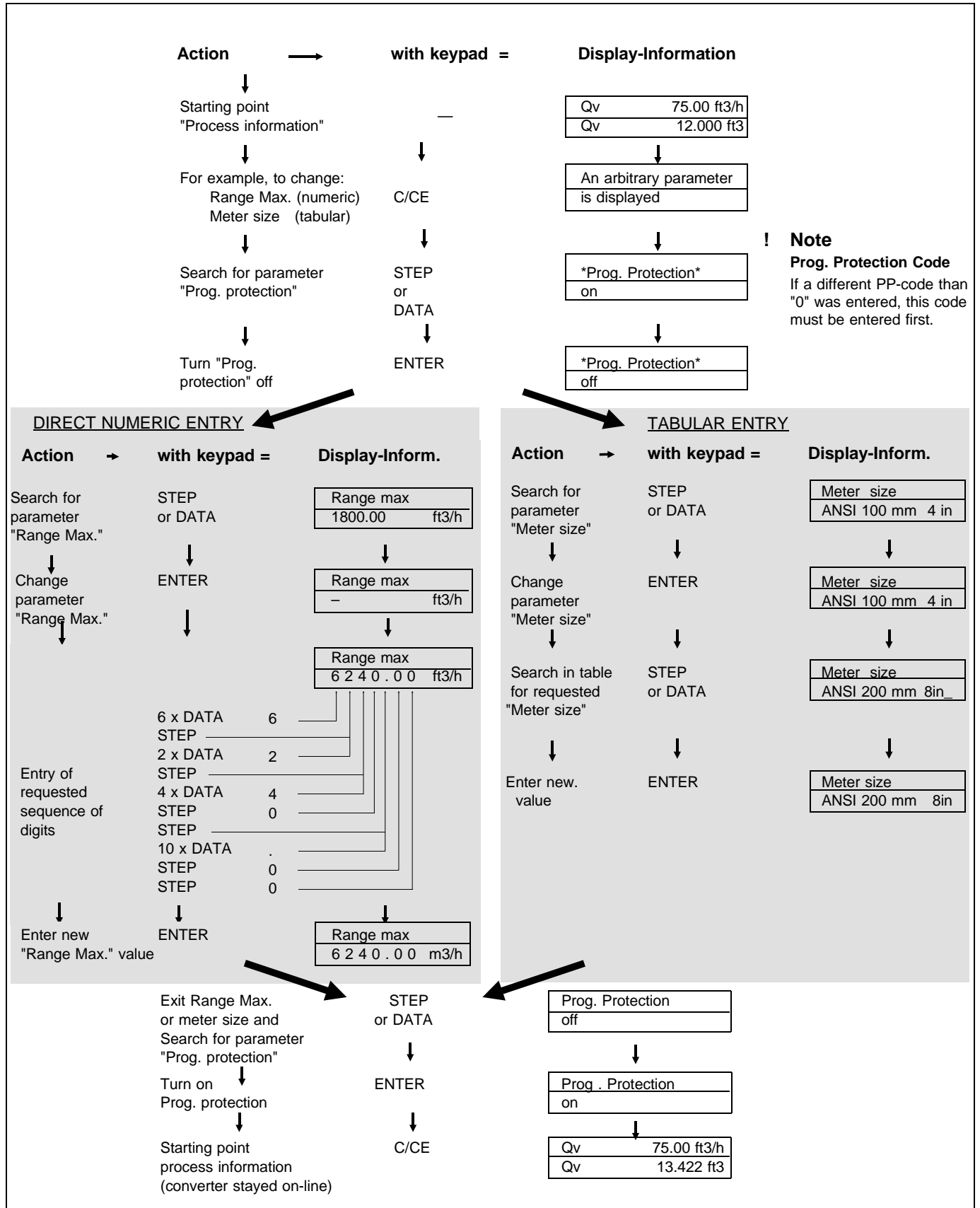

3.4 Parameter Summary and Data Entry

Submenu / Parameter	Entry Mode (Tabular / Numeric)	Description
<div style="border: 1px solid black; padding: 2px; width: fit-content;">10VT1000 03/95 D699B117U01 A.52</div>	Read-Only	Display of Model number, firmware date, firmware part number and firmware version.
<div style="border: 1px solid black; padding: 2px; width: fit-content;">Prog. Protection On</div>		Data entry is only possible by turning "Prog. Protection" off
Enter		"Prog. Protection" is "ON", by default, when power is first applied.
<div style="border: 1px solid black; padding: 2px; width: fit-content;">Prog. Protection Off</div>		Selections available: on / off
<div style="border: 1px solid black; padding: 2px; width: fit-content;">Language English</div>	Tabular	Press C/CE to exit submenu
Enter		
<div style="border: 1px solid black; padding: 2px; width: fit-content;">Language English</div>		Selects whether menus are displayed in German or English
<div style="border: 1px solid black; padding: 2px; width: fit-content;">Language German</div>		
<div style="border: 1px solid black; padding: 2px; width: fit-content;">Primary Vortex</div>		
<div style="border: 1px solid black; padding: 2px; width: fit-content;">Fluid Liquid</div>	Tabular	Press C/CE to exit submenu
Enter		
<div style="border: 1px solid black; padding: 2px; width: fit-content;">Fluid Gas</div>		Selects the proper process fluid for the application
<div style="border: 1px solid black; padding: 2px; width: fit-content;">Fluid Liquid</div>		
<div style="border: 1px solid black; padding: 2px; width: fit-content;">Meter Size ANSI 150mm 6 in</div>	Tabular	Selections: ANSI Sizes - <ul style="list-style-type: none"> 1/2 in. (15 mm) * 1 in. (25 mm) 1-1/2 in. (40 mm) 2 in. (50 mm) 3 in. (80 mm) 4 in. (100 mm) 6 in. (150 mm) 8 in. (200 mm) 10 in. (250 mm) 12 in. (300 mm)
<div style="border: 1px solid black; padding: 2px; width: fit-content;">Median k-factor</div>	Read-Only	* this size is presently not available Displays Median K-Factor. Independent of whether Median or Linearization is selected in K-Factor submenu.

Submenu / Parameter	Entry Mode	Description
Flow Mode Actual Flow	Tabular	Press <input type="button" value="C/CE"/> to exit submenu
Enter	Flow Mode Actual Flow	
	Flow Mode Standard Flow	Selects the desired flow measurement mode. The appropriate units must be chosen using the "Unit" menus.
	Flow Mode Mass Flow	
Compressibility 1.00 *	Numeric	Conversion factor required for Standard Flow. Allows entry of numbers between 0.001 and 1000.
Unit Density **	Tabular	Selectable units are: g/ml, g/cm³, g/l, kg/l, kg/m³, lb/ft³, lb/ugl
Actual Density **	Numeric	Allows entry of numbers between 0.001 and 1000.
Unit Qv ft ³ /m	Tabular	Selectable units are: l/s, l/m, l/h, igps, igpm, igph, igpd, usgps, usgpm, usgph, usgpd, ft³/s, ft³/m, ft³/h, ft³/d, m³/s, m³/m, m³/h, m³/d, bbl/s, bbl/m, bbl/h, bbl/d. Note: bbl = 42 gallons
Unit Qm **	Tabular	Selectable units are: g/s, g/m, g/h, kg/s, kg/m, kg/h, kg/d, t/m, t/h, t/d, lb/s, lb/m, lb/h, lb/d Note: t = metric tons (1000kg)
Meter Range Max	Read-Only	Indication of maximum volumetric flow rate based on meter size and fluid selected. This parameter may be programmed to a different value by selecting "Programmable" from the "Meter Range Max" menu that becomes available after entering the code number.

* Only appears if "Standard Flow" is selected as the flow mode

** Only appear if "Mass Flow" is selected as the flow mode

10VR1000 VORTEX FLOWMETER INSTRUCTION BULLETIN

Submenu / Parameter	Entry Mode	Description
Range Max	Numeric	Flow rate at which the output current becomes 20mA. Value must be between 15% and 115% of Meter Range Max.
Range Min	Numeric	Flow rate at which the output current becomes 4mA. If set to value other than zero, output current will be forced to 4mA at \leq the Range Min value. Value must be equal to or less than 10% of Meter Range Max.
Submenu Totalizer	Tabular	Press <input type="button" value="C/CE"/> to exit submenu
Enter	Function Totalizer reset	Value of Totalizer may be reset by pressing <input type="button" value="Enter"/>
	Unit totalizer ft3	Selections for Actual & Standard Flow: ft3, usgal, igal, bbl, l, m3 Selections for Mass Flow: kg, t, lb, g
	Totalizer Qv	Shows accumulated value of flow units.
	Overflow 0	Incremented each time the Totalizer value exceeds its 10,000,000 maximum count. Capacity of overflow register is 65,535 counts.
Submenu Pulse Output	Numeric	Press <input type="button" value="C/CE"/> to exit submenu
Enter	Pulse factor 100.00 1/ft3	This parameter requires special hardware that is presently not available.
	Pulse width	
Damping 3.0 s	Numeric	Controls the rate at which the unit responds to changes in the process flow rate. Allows entries of numbers between 1.0 and 100 seconds.

Submenu / Parameter	Entry Mode	Description
<div style="border: 1px solid black; padding: 2px; width: fit-content;">Submenu Current Output</div>	<p style="text-align: center;">Tabular</p>	<p>Press C/CE to exit submenu</p>
<div style="border: 1px solid black; padding: 2px; width: fit-content;">Enter</div>	<div style="border: 1px solid black; padding: 2px; width: fit-content;">Current output Current + HART</div>	<p>Selections available: Current + HART Current + pulse *</p>
		<p>* Presently not available</p>
<div style="border: 1px solid black; padding: 2px; width: fit-content;">Enter</div>	<div style="border: 1px solid black; padding: 2px; width: fit-content;">Iout at alarm 22.40 mA</div>	<p>Selections available: 3.85 mA 22.40 mA</p>
		<p>Sets the output current to the selected current value in response to Errors 5 (EEPROM) or 6 (Totalizer) conditions.</p>
<div style="border: 1px solid black; padding: 2px; width: fit-content;">Submenu Display</div>	<p style="text-align: center;">Tabular</p>	<p>Press C/CE to exit submenu</p>
<div style="border: 1px solid black; padding: 2px; width: fit-content;">Enter</div>	<div style="border: 1px solid black; padding: 2px; width: fit-content;">Display 1. line Qv actual flow</div>	<p>Allows both lines of the digital display to be independently configured to indicate different process parameters.</p>
		<p>Selections (for each display line) are : Qn standard flow * Qv actual flow Qm mass flow ** Percent Bargraph Totalizer Frequency</p>
<div style="border: 1px solid black; padding: 2px; width: fit-content;">Enter</div>	<div style="border: 1px solid black; padding: 2px; width: fit-content;">Display 2. line Totalizer</div>	<p>* Only appears if Standard Flow is selected as Flow Mode ** Only appears if Mass Flow is selected as Flow Mode</p>
<div style="border: 1px solid black; padding: 2px; width: fit-content;">Submenu Self-Check</div>	<p style="text-align: center;">Tabular</p>	<p>Press C/CE to exit submenu</p>
<div style="border: 1px solid black; padding: 2px; width: fit-content;">Enter</div>	<div style="border: 1px solid black; padding: 2px; width: fit-content;">Function NVRAM</div>	
	<div style="border: 1px solid black; padding: 2px; width: fit-content;">Function EPROM</div>	
	<div style="border: 1px solid black; padding: 2px; width: fit-content;">Function EEPROM</div>	
	<div style="border: 1px solid black; padding: 2px; width: fit-content;">Function Iout</div>	
	<div style="border: 1px solid black; padding: 2px; width: fit-content;">Function Fout</div>	<p>Performs functional check of internal hardware and sub-systems. Additional self-check parameters are shown on the following page.</p>

Submenu / Parameter	Entry Mode	Description
<div style="border: 1px solid black; padding: 2px; width: fit-content;">Submenu Error Register</div>	<div style="border: 1px solid black; padding: 2px; width: fit-content;">Function HART-Transmitter</div>	<p>Additional functional check parameters</p>
	<div style="border: 1px solid black; padding: 2px; width: fit-content;">Function HART-Command</div>	
	<div style="border: 1px solid black; padding: 2px; width: fit-content;">Function Display</div>	
	<p>Tabular</p>	<p>Press C/CE to exit submenu</p>
		<div style="border: 1px solid black; padding: 2px; width: fit-content;">Error register ... 5 ...</div>
<div style="border: 1px solid black; padding: 2px; width: fit-content;">Enter</div>	<div style="border: 1px solid black; padding: 2px; width: fit-content;">Mains interrupt 3</div>	<p>Shows the number of power interruptions that have occurred since the last time the Error Register was reset.</p>

Submenu / Parameter	Entry Mode	Description
The following menu parameters appear when the unit's Code Number is entered		
Code Number ****	Numeric	Entering the 4-digit code number causes the menu functions shown below to appear. Default code number is 1000.
Instrument Number	Numeric	An instrument identification number may be entered for "ID" purposes. Number must be less than 65,535.
Submenu k-factor	Tabular / Numeric	Press <input type="button" value="C/CE"/> to exit submenu
Enter	k-Linearization Median	Selections available: Median 5 points 4 points 3 points 2 points
Enter	Median k-factor 52000 1/m3	Allows numeric entry of median k-factor value if "Median" is selected above.
Enter	f1 2500 Hz	Allows numeric entry of "f" and "k" value sets if any of the "point-linearization" options above are selected. One "f" and "k" value set per linearization point is required.
Enter	k1 52000 1/m3	
Meter Range Max Fixed	Tabular	Press <input type="button" value="C/CE"/> to exit submenu
Enter	Meter Range Max Fixed	
Enter	Meter Range Max Programmable	Selects whether the "Meter Range Max" parameter is the read-only value determined by the firmware or may be numerically programmed by the user.

Submenu / Parameter	Entry Mode	Description
Function Reset Error	Enter	Pressing "Reset" function clears all error codes that have accumulated in the Error Register.
Function Init EEPROM	Enter	Pressing "Reset" function initializes EEPROM and restores any programmed parameters stored there to their default values.
Function Adjust Iout 4mA	Numeric	Enables precise calibration of 4mA output current.
Function Adjust Iout 20mA	Numeric	Enables precise calibration of 20mA output current.
Function Minimum Current		Press <input type="text" value="C/CE"/> to exit submenu
Enter	Test min current	Shuts off output current regulation and allows measurement of the current being consumed by the electronics. This current must be less than 4mA for proper operation.
Error 9 Off	Tabular	Press <input type="text" value="C/CE"/> to exit submenu
Enter	Error 9 On	Allows control of whether output current "latches" at the alarm value in response to an overrange condition, requiring a manual reset to restore normal operation after the overrange condition is corrected. Selections available: on / off

4.0 START-UP AND OPERATION

4.1 Start-Up

Prior to initial system start-up, verify that the meter is properly installed. Check flow direction as indicated on the meter body and wiring interconnections as shown in Figures 2-9 or 2-10 of Installation Chapter 2.0.

Verify that the power supply is the correct value according to the power requirements of the signal converter and that it is connected with the proper polarity.

If everything is properly installed and connected, turn on the power to the meter. The LCD display should become active and display the selected flow information in two lines.

Using the pushbuttons located in the signal converter interconnection junction box (see Sections 2.7 and 3.2), verify that the correct operating parameters have been entered as described in this section.

If everything appears to be operating properly, initiate process flow through the flowmeter. Flow measurement and output signal transmission should begin as the process fluid flows through the meter.

4.2 Error Messages

Error messages replace the flow rate indication in the top line of the display when certain failure conditions exist or when an attempt has been made to enter an unacceptable value.

TABLE 4-1. DEFINITION OF ERROR MESSAGES

Error Code	Description	Cause
3 (a)	Flowrate > 115%	Flowrate is greater than 115% of Range Maximum.
5 (b)	EEPROM Defect	Data error in EEPROM.
6	Totalizer Error	Totalizer value is invalid.
9 (c)	Qv > 115% Qmax DN	Flowrate greater than 115% of Meter Range Maximum.

(a) Self-resetting alarm condition. Normal operation resumes when alarm condition clears.

(b) Refer to Sub-Section 4.3.24.4 & 4.3.24.5.

(c) This alarm condition forces the output current to 22.4 mA and to "latch" there. It is not self-resetting. When the alarm condition has cleared, the meter may be reset by pressing any button on the keypad. Code 9 can be disabled per Sub-Section 4.3.24.9.

4.3 Menu Display and Selections

<p>NOTE</p> <p>Normal measurement range extends to 115% of Meter Range Max.</p>

<p>NOTE</p> <p>The abbreviations shown in Table 4-2 are applicable to the Unit menu selections in Section 4.3.</p>
--

TABLE 4-2. UNITS OF MEASURE

Abbreviations	Definition
usgal	US gallons
igal	imperial gallons
bbl	barrels (42 gallons)
l	liters
ml	milliliters
m ³	cubic meters
cm ³	cubic centimeters
ft ³	cubic feet
kg	kilograms
t	metric tons
lb	pounds
g	grams

4.3.1 Firmware Version

The firmware level and the model number are shown in the display with the model number and firmware release date on the top line and the EPROM identification and firmware level on the bottom line. Changes to the firmware can only be made by replacing the EPROM. When communicating with Bailey-Fischer & Porter, please reference the firmware version of the instrument.

The Functional Flowchart shown in Figure 4-1 gives a pictorial overview of the top-level menu structure of this version of firmware. Functions of these menu parameters and their sub-menu breakdowns are explained in more detail following the flowchart.

10VT1000	03/95
D699B117U01	A.52

4.3.2 Program Protection

The Program Protection is automatically turned **ON** during power-up. Parameters **cannot** be changed when Program Protection is **ON**. Parameters can only be changed when the Program Protection is in the **OFF** mode. To change from ON to OFF (or vice-versa), press ENTER. When changing calibration parameters (see Code Number sub-section 4.3.24), Program Protection is automatically turned off when the code number is entered. Program Protection will automatically revert to **ON** if not done manually.

Program Protection

Menu Choices: on
 off

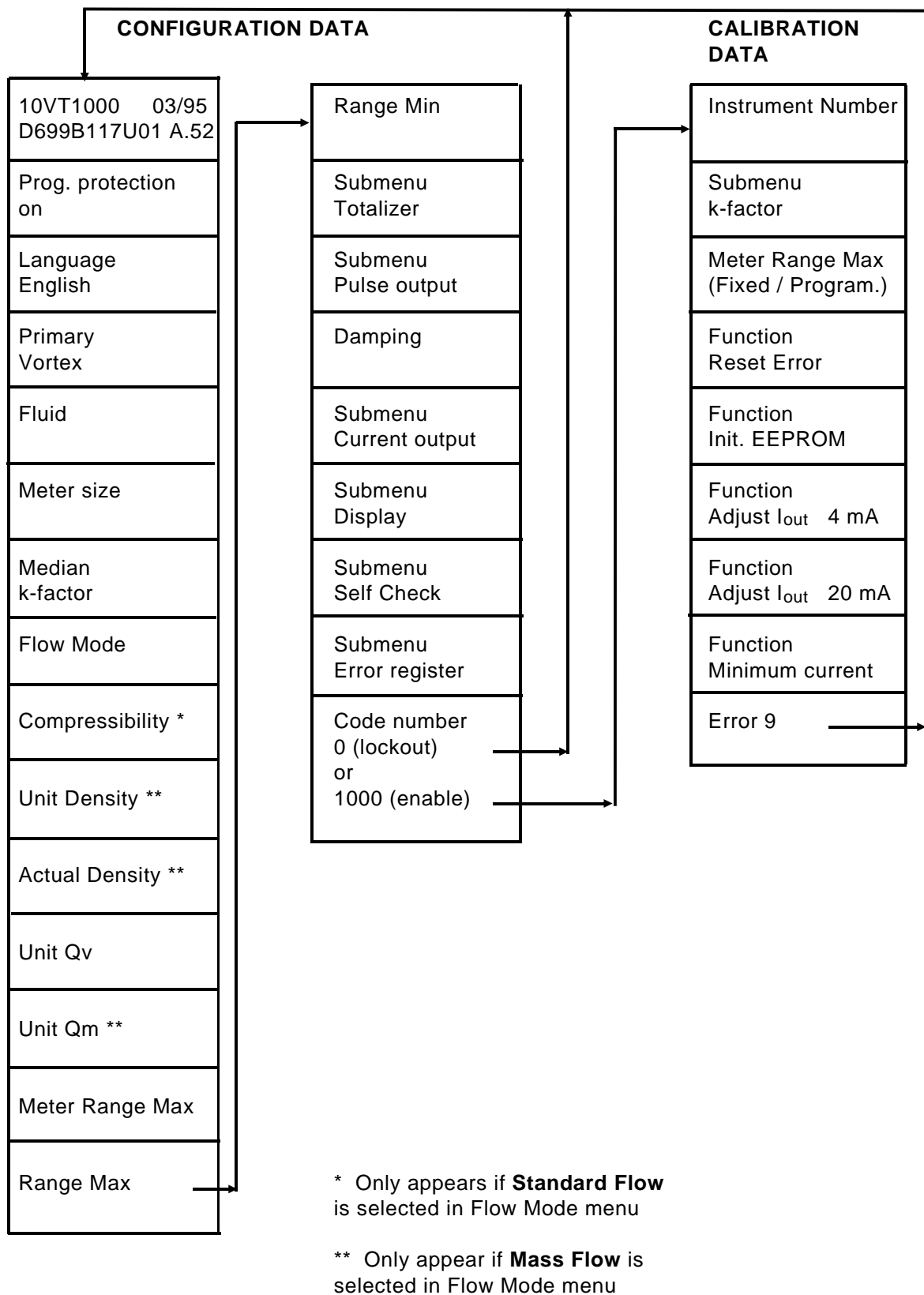

FIGURE 4-1. FLOWCHART OF PARAMETERS

4.3.3 Language

Menu choice "English" is entered by Bailey-Fischer & Porter. To change this selection, press ENTER and use the arrow keys to change the selection; then press ENTER.

Language English

Menu Choices: English
 German

4.3.4 Primary

Entered by Bailey-Fischer & Porter.

Primary Vortex

See NOTE A.

Menu Choices: Vortex
 Swirlmeter (not applicable)

4.3.5 Fluid

To select the appropriate process fluid, press ENTER and use the arrow keys to make a selection; then press ENTER.

Fluid

See NOTE A.

Menu Choices: Gas
 Liquid

4.3.6 Meter Size

Enter the applicable meter size. Only the menu choices that appear in the following table are applicable to meters built in the US by Bailey-Fischer & Porter. To make an entry, press ENTER and use the arrow keys to scroll through the menu. When the appropriate size appears, press ENTER and the size will be entered into memory.

Meter Size

See NOTE A.

Menu Size Choices	
inches	mm
1/2*	15*
1	25
1 1/2	40
2	50
3	80
4	100
6	150
8	200
10	250
12	300

* This meter size is not presently available

<p>NOTE A: Primary, Fluid & Meter Size selections in Sections 4.3.4, 4.3.5 & 4.3.6 respectively will be replaced by asterisks (*) if "Programmable" is selected as the parameter in Section 4.3.24.3.</p>
--

4.3.7 Median k-factor

This menu provides a means for monitoring the average k-factor value regardless of how many points were selected for the linearization in Sub-Section 4.3.24.2. This is a read only parameter and the value that appears on the display must match the value stamped on the meter's Model Number tag. Units for this "meter-constant" parameter are cycles/m³.

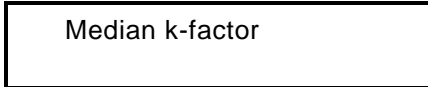

4.3.8 Flow Mode

To select the desired flow mode, press ENTER and use the arrow keys to make a selection. Once the selection is made, press ENTER to save it.

Actual flow - actual volumetric flow

Mass flow - mass flow using operating density

Standard flow - standard flow under standard temperature and pressure conditions

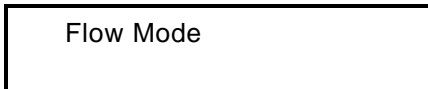

Menu Choices: actual flow
 mass flow
 standard flow

4.3.9 Compressibility

This menu appears only if Standard flow is selected for the Flow Mode. This number must be entered to convert the measured process flow to Standard flow conditions based on the specific process operating pressure and temperature conditions.

The compressibility factor to be entered is calculated from the following equation:

$$\text{Compressibility} = \left(\frac{P}{14.7} \right) \times \left(\frac{530}{460 + T} \right)$$

where: P = process operating pressure in psia
 T = process operating temperature in °F

Range of entry values permitted is 0.001 to 1000.

4.3.10 Unit Density

Used with Mass Flow only (refer to Section 4.3.8). To make an entry, press ENTER and use the arrow keys to scroll through the menu. When the appropriate selection appears, press ENTER.

Unit Density

Menu Choices:
g/ml
g/cm ³
g/l
kg/l
kg/m ³
lb/ft ³
lb/ugl

4.3.11 Actual Density

Enter operating density in applicable units selected in Section 4.3.10 - **used with Mass Flow only (refer to Section 4.3.8)**. To make an entry, press ENTER and use the "STEP" and arrow keys to enter a value, then press ENTER.

Actual density

4.3.12 Unit Qv (volumetric)

Used with Actual & Standard Flow Modes only (refer to Section 4.3.8). To make an entry, press ENTER and use the arrow keys to scroll through the menu. When the appropriate selection appears, press ENTER.

Unit Qv

Menu Choices:					
l/s	igps	usgps	ft ³ /s	m ³ /s	*bbl/s
l/m	igpm	uspm	ft ³ /m	m ³ /m	*bbl/m
l/h	igph	usgph	ft ³ /h	m ³ /h	*bbl/h
---	igpd	usmgd	ft ³ /d	m ³ /d	*bbl/d

*bbl = 42 gallons

4.3.13 Unit Qm (mass flow)

Used with Mass Flow only (refer to Section 4.3.8). To make an entry, press ENTER and use the arrow keys to scroll through the menu. When the appropriate selection appears, press ENTER.

Unit Qm

Menu Choices:			
g/s	kg/s	*t/m	lb/s
g/m	kg/m	*t/h	lb/m
g/h	kg/h	*t/d	lb/h
---	kg/d	---	lb/d

* t = metric tons (1000 kg)

4.3.14 Meter Range Maximum (Q_{max} DN)

Maximum volumetric flow rate per meter size. This parameter may be programmed as described in Section 4.3.24.3. Range maximum (which determines the flow rate where output current equals 20 mA) is set as described in Section 4.3.15.

Meter Range Max

NOTE
If Mass Flow is selected as the flow mode in Section 4.3.8, the units of Meter Range Max. will continue to be displayed in the volumetric flow units selected in Section 4.3.12.

4.3.15 Range Maximum (Q_{max})

Range Maximum is the flow rate at which the output shall be equal to 20 mA. Use the STEP and DATA keys to enter a value that corresponds to 20 mA. Value must be between 15% and 115% of Meter Range Maximum [Q_{max} DN] (refer to Section 4.5.14).

Range Max

If **Mass Flow** is selected in Section 4.3.8, the **Range Max** units will be displayed in the units selected for Q_m in Section 4.3.13 while **Meter Range Max.** and **Range Min.** will continue to be displayed in the volumetric units selected in Section 4.3.12. For comparison purposes, the volumetric units value for **Range Max** can be calculated from the following equation:

$$Q_v = \frac{Q_m}{DENSITY}$$

where Q_v = Volumetric flow rate
 Q_m = Mass flow rate
 Density = Actual Density value entered in para. 4.3.11

4.3.16 Range Minimum (Q_{min})

When flowrate is below Range Minimum the output is driven to 4 mA. Use the STEP and DATA keys to enter a value that corresponds to the minimum volumetric flow to be displayed; then press ENTER. Zero flow equals 4 mA. Value must be equal to or less than 10% of Meter Range Maximum (refer to Section 4.3.14).

Range Min

NOTE
If Mass Flow is selected as the flow mode in Section 4.3.8, the units of Range Min. will continue to be displayed in the volumetric flow units selected in Section 4.3.12.

4.3.16.1 Current Output vs. Range Min. Setting

The operation of the current output is shown graphically in Figure 4-2 below. If flow is above the value of the Range Min (Q_{min}) setting, the current follows a linear path which is determined by a straight line passing between 4mA at zero flow and 20mA at the Range Max. (Q_{max}) value. The output current is forced to 4mA when flow conditions fall below the value of the Range Min. (Q_{min}) setting.

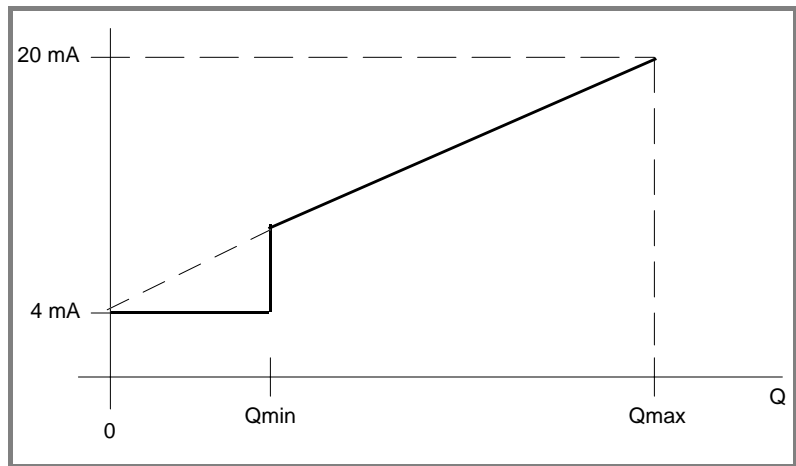

FIGURE 4-2. CURRENT OUTPUT OPERATION

4.3.17 Sub Menu Totalizer

4.3.17.1 Unit Totalizer

To make an entry, press ENTER and use the arrow keys to scroll through the menu. When the appropriate selection appears, press ENTER. The appropriate **Flow Mode** must be selected in Section 4.3.8.

Unit Totalizer

Totalizer menu selections:

Menu Choices:	
Actual flow	Mass flow
usgal	kg
igal	**t
*bbl	lb
l	g
m ³	---
ft ³	---

*bbl = 42 gallons

**t = metric tons (1000 kg)

4.3.17.2 Totalizer

The totalizer sums the flow in accordance with the selected flow mode. An overflow is activated each time the totalizer count exceeds 10,000,000 (refer to Section 4.3.17.3). The maximum number of overflows which can be stored in the overflow register is 65,535. Therefore, the maximum totalizer count is:

$$65,535 \times 10,000,000 = 655,350,000,000$$

This is a read only parameter.

Totalizer

4.3.17.3 Overflow

When the **totalizer** reaches its maximum count it "rolls over" to zero. Each "roll over" is counted as an **overflow** and stored in the overflow register. This is a read only parameter.

Example:

Number of overflows = 12
 Maximum totalizer count = 10,000,000
 Present totalizer count = 4,789

$$12 \times 10,000,000 = 120,000,000$$

$$120,000,000 + 4,789 = 120,004,789$$

Overflow
0

4.3.17.4 Function Totalizer Reset

Press ENTER to reset the totalizer and overflow to zero.

Function
Totalizer reset

4.3.18 Sub Menu Pulse Output

This parameter requires special optional equipment and is not presently available with A.52 firmware.

Sub Menu
Pulse Output

4.3.19 Damping

Damping controls the rate at which the unit responds to changes in flow. Without damping, it will show a 100% change in flow in approximately 1 second. By entering various values for damping, the full scale response can be slowed to 100 seconds. This is not a linear function. Response will be faster in the first few seconds of the damping interval than during the last few seconds. Damping is used to smooth out pulsating flow signals that are caused by pumps and to reduce output oscillations that are created by process generated noise.

Use the STEP and DATA keys to make the necessary entries. Then press ENTER.

Damping

Valid Numerical Entries: 1.0 through 100s

4.3.20 Sub Menu Current Output

4.3.20.1 Current Output

Submenu
Current output

Menu Choices: current + pulse *
current + HART

* Pulse decoding is presently not available.

4.3.20.2 I_{out} at Alarm

I_{out} at alarm sets the output current to a low or high value (as selected) in response to Error 5 (EEPROM) or Error 6 (Totalizer) alarm conditions. In case of an operational failure, the computer activates an alarm, an error message is sent to the display, and the current output is determined by the value selected in this menu.

I_{out} at alarm

Valid Numerical Entries: 3.85 mA
22.40 mA

NOTE
The value of the output during the flow-alarms (Error 3 & Error 9) is independent of the selection in this menu and will always be forced to the high-current value.

4.3.21 Sub Menu Display

There are several options available for flow value displays. The first and second lines of the display can be programmed in this menu.

To make an entry, press ENTER and use the arrow keys to scroll through the menu. When the appropriate selection appears, press ENTER.

4.3.21.1 Display 1. line

Select a parameter to be shown on the first line of the LCD display.

display 1. line

Menu Choices: Qv actual flow
 Qm mass flow *
 Qn standard flow **
 Percent
 Bargraph
 Totalizer
 Frequency

where:

Qv = volumetric flow
Qm = mass flow
Qn = standard flow
Percent = Flowrate in the selected flow units as a percent of the selected maximum flowrate (Range max).
Bargraph = as percent, except displayed as a bar and percent
Totalizer = sum of flowrate
Frequency = vortex frequency in Hz measured by the converter

4.3.21.2 Display 2. line

Select a parameter to be shown on the second line of the LCD display.

display 2. line

Menu Choices: Qv actual flow
 Qm mass flow *
 Qn standard flow **
 Percent
 Bargraph
 Totalizer
 Frequency

* Only appears if Mass Flow is selected in "Flow Mode" menu

** Only appears if Standard Flow is selected in "Flow Mode" menu

4.3.22 Sub Menu Self Check

Self Checks are firmware-driven test routines. Use the arrow keys to scroll through the menu

Sub Menu
Self Check

Press enter at this sub-menu to enter its self-test functions:

Function
I_{out}

Press enter at this sub-menu and the "Test I_{out}" display will appear:

Test I_{out}
___ %

A percentage of the output current can be entered up to 115% of the maximum range. The output current will then change to that value.

Note

If a value greater than 115% is entered, an error message that I_{out} must be less than 115% is displayed and the output current will not enter the self-check mode but will remain at its previous value.

Press enter to stop the test.

Function
F_{out}

This parameter is linked to the Pulse Output Sub-Menu (para. 4.3.18) and is not presently available with version A.52 firmware.

Function
HART-Transmitter

Press enter to begin the HART transmitter test mode:

HART Transmitter
0 = pulse

Converter transmits a 2200 Hz (logic 0) signal on the current output lines. Pressing any key will change the output to test the 1200 Hz (logic 1) signal. These signals may be observed by connecting an oscilloscope across a 250 ohm load resistor connected in series with the current output lines.

HART Transmitter
1 = no pulse

Function
HART-Command

Pressing "ENTER" will allow display of the HART command code after a HART test transmission has been sent. Asterisk (*) blinks momentarily after each received command. "Slot" indication is only displayed for 128 - 133 Slot commands. For factory test only

HART-Command
128 Slot 20 *

Function
Display

The characters 1234567890ABCDEF are displayed on each display line as a display check.

Function
NVRAM

Self-tests non-volatile RAM

Function
EPROM

Self-tests EPROM

Function
EEPROM

Self-tests EEPROM

4.3.23 Sub Menu Error Register

All error messages and power outages are stored in these registers. The error numbers displayed are a code which identifies the type of error. Refer to Table 4-1.

Sub Menu
Error register

Menu choices: Error Register
 Mains interrupt

4.3.23.1 Error Register

Indicates code numbers of any errors that have occurred since the last time the error register was reset (refer to Table 4-1). The error register can be reset with the Error Reset parameter 4.3.24.4.

Error Register
.....

4.3.23.2 Mains Interrupt

Indicates the number of power outages that have occurred since the last time the unit was turned on. The mains interrupt can be reset with the Error Reset parameter 4.3.24.4.

Mains interrupt
4

Press C/CE to return to the sub-menu.

4.3.24 Code Number

Access to calibration parameters is achieved by entering the proper code number. In order to enter the "**calibration mode**" it is necessary to enter the number "1000". The calibration mode is locked out with the entry of a number other than 1000, after a power-on reset or if no key-entry has been made for ten minutes. The code number is pre-programmed and may not be changed.

After the correct code number has been entered the program protection (see Section 4.3.2) is automatically turned OFF. Access is terminated if an incorrect code number is entered. Entering an incorrect number will automatically turn program protection ON.

To enter a code number, use the **STEP** or **DATA** keys until the following display appears. Use the **Enter** function then the **STEP** and **DATA** keys to enter the code number (refer to Chapter 3.0 for an explanation of data entry using the push-buttons). For security purposes, each digit of the code number is replaced by an asterisk on the display after it is entered.

Code Number

Ten minutes after the last key has been pressed the code number mode **is deactivated and program protection is turned ON.**

The parameters that follow only appear in the Code Number mode.

4.3.24.1 Instrument Number

The instrument number is entered by Bailey-Fischer & Porter. It may be used to uniquely identify an individual meter if several meters are on site. Typically, the last four digits of the unit's Serial Number are entered by the factory but the number may be changed by the user, if desired, using the normal data entry procedure described earlier. The register will accept 8-digits but the instrument number value must be ≤ 65535

Instrument Number

4.3.24.2 Sub Menu k-factor

NOTE
The meter is programmed (configured) by Bailey-Fischer & Porter prior to shipment. Therefore, the meter should not require k-factor adjustment in the field.

The k-factor is the relationship between sensor frequency and volumetric flow rate, and is used to calculate the flowrate at operating conditions. The k-factor is a function of the size of the flowmeter. To maximize accuracy a linearizing algorithm is provided that uses 2, 3, 4, or 5 values. If only one value is required, "Median" is selected. The median k-factor is stamped on the instrument tag and may also be read on the display as described in Section 4.3.7.

The factory-determined k-factors for linearization are listed on a paper label included with the instrument for reference. This is located on the inside of the cover of the signal converter connection box where the STEP, DATA & C/CE push-button switches are located.

To access the k-factor sub-menu, press ENTER and the following display will appear.

Submenu
k-factor

Press ENTER again and the following display appears. Use the arrow keys to make a selection; then press ENTER.

k-Linearization

Menu Choices: 2 points
 3 points
 4 points
 5 points
 Median

If a "points" selection was made refer to Sub-Section 4.3.24.2.1.

If "Median" was selected refer to Sub-Section 4.3.24.2.2

4.3.24.2.1 K-Factor linearization

This menu is available if 2 through 5 point calibration has been selected. It is possible to enter up to 5 calibration values in this menu (over the flowrate range). An interpolation is made between the entered points. First enter frequency f1 and then the corresponding k1 in cycles/m³. Repeat this procedure until all the calibration points (2 through 5) have been entered.

For example:

For 2 points enter the following values:

f1	k1
f2	k2

For 3 points enter the following values:

f1	k1
f2	k2
f3	k3

All frequencies must be less than 2500 Hz. The points must be entered in ascending order; f1 < f2 < f3 < f4 < f5. Use the STEP and DATA keys to make the necessary entries. Then press ENTER. Press C/CE to go to the next parameter.

f 1 100 Hz

Range = 1 - 2500

k 1 1000.0 1/m ³

1/m³ represents cycles/m³

Range = 0.0 - 2,000,000

4.3.24.2.2 Median k-factor

This menu is available if Median has been selected in the k-factor menu. The median k-factor stamped on the instrument tag is entered. The k-factor is in cycles/m³. This is a read only parameter. Press C/CE to go to the next parameter.

Median k-factor 1000.0 1/m ³
--

1/m³ represents cycles/m³

Range = 0 - 2,000,000

4.3.24.3 Selectable Meter Range Maximum

This menu allows the option of whether Meter Range Max (see Section 4.3.14) is to be a fixed value or programmable. When **Fixed** is selected, the value of Meter Range Max is determined by the firmware based on meter size and fluid. Selecting **Programmable** allows the numerical Meter Range Max menu parameter to be programmed by the user.

Meter Range Max

Menu Choices: Fixed
Programmable

If **Programmable** is desired, a range value may be entered into the numerical Meter Range Max menu parameter (Section 4.3.14) up to a maximum limit of 1,000,000. The maximum limit is independent of the measurement units selected in the Units Qv menu parameter. The Meter Range Max value entered is also automatically entered as the Range Max value; the Range Min value remains unchanged. The range of values which may be entered for Range Max. remains unchanged at 15% to 115% of Meter Range Max. while the allowable range for Range Min. values stays the same at 0% to 10% of Meter Range Max.

NOTE
If "Programmable" is chosen as the Meter Range Max parameter, the normal Primary, Meter Size and Fluid menu contents are replaced by asterisks (*****) and no menu entry or selection is allowed for those parameters.

4.3.24.4 Function Reset Error

The individual error codes and mains interrupts are stored in the Error Register (Refer to Section 4.3.23) until the reset in this menu is activated by pressing the ENTER key.

Function
Reset error

4.3.24.5 Function Initialize EEPROM

If the display indicates an **Error 5 - EEPROM** periodically, initializing the EEPROM may prevent having to return the meter to the factory for repair. Press ENTER to initialize the EEPROM followed by Reset Error (refer to Section 4.3.24.4) to clear the error indication. **Initializing the EEPROM will require re-entry of some of the stored data.**

Function
Init EEPROM

NOTE
If initialize is selected, several parameters are set to their default values. Make a note of all stored values before initializing the EEPROM since some configuration data must be re-entered following initialization.

4.3.24.6 Function Adjust I_{out} 4 mA

A milliammeter connected in series with the output terminals is required for the output current calibration. Upon selection of Adjust I_{out} 4 mA the converter produces **approximately** 4 mA at the output terminals. The **exact** value of the current is determined with the milliammeter and entered manually using the "STEP" and "DATA" buttons to calibrate the output current. Verify by entering 0% for I_{out} Self Check (refer to 4.3.22).

Function Adjust I _{out} 4 mA
--

4.3.24.7 Function Adjust I_{out} 20 mA

A milliammeter connected in series with the output terminals is required for the current calibration. Upon selection of Adjust I_{out} 20 mA the converter produces **approximately** 20 mA at the output terminals. The **exact** value of the current is determined with the milliammeter and entered manually using the "STEP" and "DATA" buttons to calibrate the output current. Verify by entering 100% for I_{out} Self Check (refer to 4.3.22).

Function Adjust I _{out} 20 mA

4.3.24.8 Function Minimum Current

This test shuts off the 4 - 20 mA current regulating circuitry and displays the current actually being used by the electronics. Under normal conditions and to obtain proper 4 mA regulation, this value should be less than 4 mA.

Function Minimum current

4.3.24.9 Error Code 9

Error code 9 can be turned **ON** or **OFF** using this parameter. When error code 9 is turned **off**, no error message will appear when the flowrate exceeds 115% of Meter Range Maximum (Section 4.3.14). When Error Code 9 is turned **on**, an error indication will appear in the error register (Section 4.3.23.1) and the output current will be forced to 22.4 mA regardless of the I_{out} at Alarm setting selected in Section 4.3.20.2. This is a "latching" alarm that is **not** self-resetting. If the cause of the alarm condition is corrected, the error code may be reset by pressing any button on the keypad. This alarm is independent of the "Range Maximum" setting in Section 4.3.15.

Error 9 off

Menu Choices: on
 off

If Meter Range Maximum is made "programmable" (as described in Section 4.3.24.3), the Error 9 alarm is still referenced to the "fixed" Meter Range Max value resident in the firmware and occurs (if enabled) at 115% of this value, as before. It will **not** occur at 115% of the "user programmed" value entered in Section 4.3.14 if "programmable" is selected in Section 4.3.24.3.

4.4 Analog Board Switches

The switches on the Analog Board customize the sensor signal noise filter characteristics to the meter size and process fluid. It is important that these switches be set correctly for proper operation of the meter. The switches are generally preset at the factory and should require no re-adjustment but if a verification of the proper settings is desired, Table 4-3 on the next page correlates the filter switch positions with the applicable meter size and process fluid.

Figures 2-7 and 4-3, below, show the location of the switches on the Analog Board Assembly. The Analog Board is located in the signal converter electronics housing. The cover of the electronics housing must be removed by removing the four bolts in order to gain access to the Analog Board Assembly.

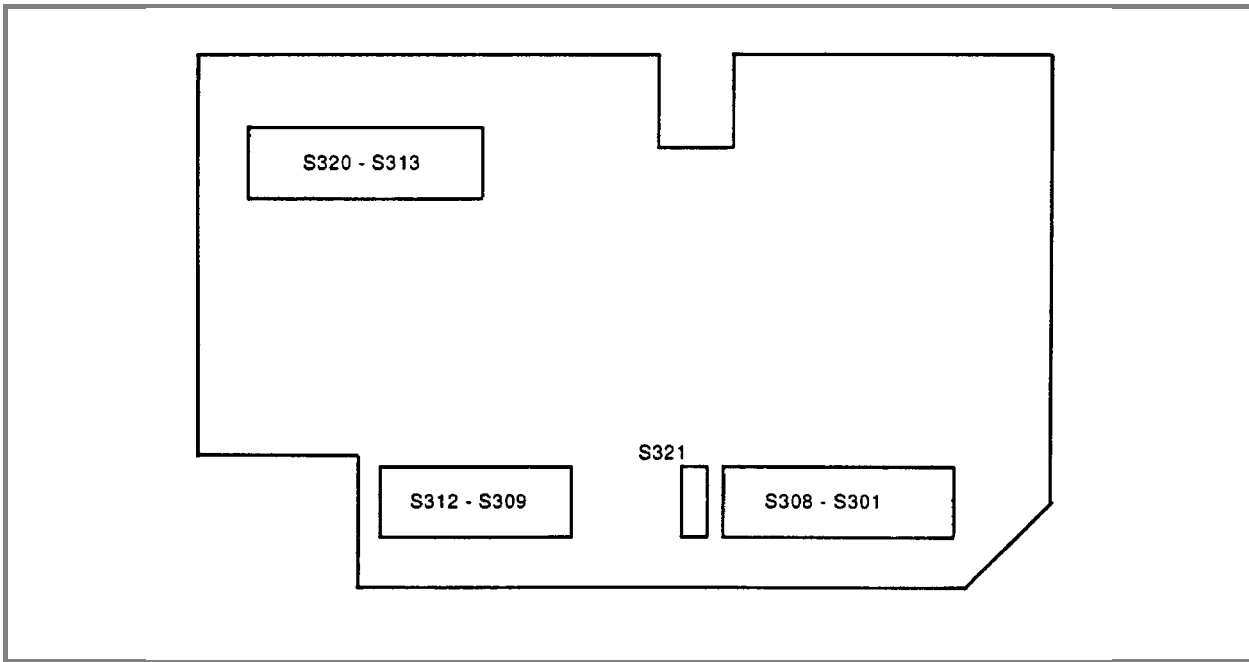

FIGURE 4-3. ANALOG BOARD SWITCH LOCATIONS

Medium	Meter Size		SWITCHES TO BE IN CLOSED OR "ON" POSITION (ALL OTHER SWITCHES MUST BE OPEN)																					
	in.	mm	S301	S302	S303	S304	S305	S306	S307	S308	S309	S310	S311	S312	S313	S314	S315	S316	S317	S318	S319	S320	S321	
Gas	.75	20	•	•			•	•			•					•								
	1	25	•	•			•	•			•					•								
	1.25	32	•	•			•	•			•					•								
	2	50	•	•			•	•			•					•								
	3	80	•	•			•	•				•					•							
	4	100			•					•		•					•							
	6	150			•					•			•					•					•	
	8	200				•				•			•					•					•	
	12	300				•				•			•					•					•	
	16	400				•				•			•							•			•	
Liquid	.75	20				•				•				•					•				•	
	1	25				•				•				•					•				•	
	1.25	32				•				•				•						•			•	
	2	50				•				•				•						•			•	
	3	80		•	•	•		•	•	•				•					•	•			•	
	4	100		•	•	•		•	•	•	•	•	•	•							•		•	
	6	150		•	•	•		•	•	•	•	•	•	•	•	•	•	•	•	•	•	•		•
	8	200		•	•	•		•	•	•	•	•	•	•	•	•	•	•	•	•	•	•		•
	12	300		•	•	•		•	•	•	•	•	•	•	•	•	•	•	•	•	•	•		•
	16	400		•	•	•		•	•	•	•	•	•	•	•	•	•	•	•	•	•	•		•

NOTE: • indicates switch to be in "closed" or "ON" position

TABLE 4-3. ANALOG BOARD FILTER SWITCH SETTINGS

5.0 TROUBLESHOOTING AND FLOW RATE TABLES

WARNING

All Flowmeters and/or Signal Converters being returned to Bailey-Fischer & Porter for repair must be free of any hazardous materials (acids, alkalis, solvents, etc.). A Material Safety Data Sheet (MSDS) for all process liquids must accompany returned equipment. Contact Bailey-Fischer & Porter for authorization prior to returning equipment.

5.1 Troubleshooting

Problem	Corrective Action
A. No indication on display when power is applied.	<ol style="list-style-type: none"> 1. Check connections to terminal block. 2. Check for dc voltage at terminal block. 3. Check polarity of power leads. 4. Check that the 5-pin analog board connector 3x4 is properly secured and plugged into the digital board connector 2x4.
B. No flow indication when flow exists through meter.	<ol style="list-style-type: none"> 1. Verify that programming switches S301 through S321 are set correctly for the meter size and fluid (refer to Sections 2.7 & 4.4). 2. Verify that all menu parameters are entered correctly. 3. Check that flow is not below the meter's minimum range setting. 4. Using the Display Sub Menu Parameter 4.3.21, configure one line of the display to indicate "Frequency". <ol style="list-style-type: none"> a) If sensor frequency is displayed, meter is defective and must be returned to Bailey-Fischer & Porter for repair. b) If no sensor frequency is displayed: <ol style="list-style-type: none"> (1) Check that the 5-pin analog board connector 3x4 is properly secured and plugged into the digital board connector 2x4. (2) Check that the sensor leads are properly secured to the analog board terminal block 3x5 pins 19 and 2B. (3) If sensor leads are properly secured, remove sensor leads from terminal block 3x5 and (if available) connect sine-wave generator leads to terminal block. Using an oscilloscope, set sine-wave generator output voltage to approximately 100 mV P-P and signal frequency to 40 Hz for liquid meters and 300 Hz for gas meters. If display shows sine-wave generator frequency and flow indication, sensor is defective and must be replaced.
C. Flow indication on display when no flow exists	<ol style="list-style-type: none"> 1. Using the Display Sub Menu Parameter 4.3.21, configure one line of the display to indicate "Frequency". 2. If display indicates power-line frequency (usually 60Hz in US), check that meter body & pipeline are properly grounded. 3. If properly grounded and problem persists, try reversing sensor leads at 3x5 terminal block terminals 2B & 19 on Analog Board (Refer to Figure 2-6). 4. Check to make sure that there is less than 15 VAC "common-mode" voltage between meter body and DC power supply
D. Low or High flow reading on display	<ol style="list-style-type: none"> 1. Check values of k-factor(s) entered. 2. Check value of meter size. 3. Check that process fluid, liquid or gas, has been selected correctly.

10VR1000 VORTEX FLOWMETER INSTRUCTION BULLETIN

E. Erratic or jumpy display	May be overly sensitive to process flow variations or characteristics. Try increasing the Damping value (Section 4.3.19) to decrease response time.
F. "Error 3 - Flow > 115%" occurs	<p>Process flowrate exceeds Range Max. setting (Refer to Section 4.3.15)</p> <ol style="list-style-type: none"> 1. Process flowrate too high. Reduce flowrate or increase Range Max. value and alarm will self-reset. 2. Process flowrate may be exceeding meter's parameters. Check that Range Max., meter size, medium, type, etc. are all set correctly. 3. Check all k-factors as discussed in Section 4.3.24.2. Make certain that k1 through k5 have been entered correctly and are the correct values according to the label inside the connection box cover which lists the proper values for k1 through k5. If linearization is being used, make sure none have been set to "0".
G. "Error 5 - EEPROM" appears	<p>Data error has occurred in EEPROM.</p> <ol style="list-style-type: none"> 1. Perform EEPROM Self-Check (See Section 4.3.22). 2. If self-check is "OK", re-initialize EEPROM (Refer to Section 4.3.24.5) 3. If self-check fails, meter must be returned to factory for repair
H. "Error 6 - Totalizer" appears	<p>Two Totalizer values stored in the instrument don't match.</p> <ol style="list-style-type: none"> 1. Reset Totalizer (Refer to Section 4.3.17.4) and start totalizing from zero
I. "Error 9 - $Q_v > 115\% Q_{max DN}$ " appears	<p>Process flow exceeds 115% of Meter Range Max.</p> <ol style="list-style-type: none"> 1. Process flowrate too high. Reduce flowrate and press any push-button key to reset when flowrate has been reduced. 2. Process flowrate may be exceeding meter's parameters. Check that meter size, medium, type, etc. are all set correctly. 3. Check all k-factors as discussed in Section 4.3.24.2. Make certain that k1 through k5 have been entered correctly and are the correct values according to the label inside the connection box cover which lists the proper values for k1 through k5. If linearization is being used, make sure none have been set to "0".
J. "Error 9" keeps reoccurring	<p>Surges in the process flow may be triggering the alarm. Try increasing the Damping value (Section 4.3.19) to slow the response time.</p>
K. Problems with HART reception or transmission	<ol style="list-style-type: none"> 1. Make sure that "Current + HART" is selected in Current Output sub-menu (Section 4.3.20). 2. Check that the value of the load resistance in series with the current output is between 250 and 500 ohms. 3. For HART reception problems, perform the "HART-Command" test in the Self Check sub-menu (Section 4.3.22). 4. For HART transmission problems, perform the "HART-Transmitter" test in the Self Check sub-menu (Section 4.3.22).
L. Moisture is found inside electronics housing	<p>Some small amount of condensation may be normal if there is a large temperature differential between inside & outside of housing. If moisture is excessive, housing gaskets in the housing covers may be damaged or not seated properly or the covers may not be tightened properly.</p> <ol style="list-style-type: none"> 1. Remove housing and/or connection box covers and inspect O-ring gaskets. If damaged, contact factory for replacements. 2. If not seated properly, correct the problem and carefully re-install the covers, making sure screws are properly tightened.

5.2 Flow Rates and Frequencies

Information in the following tables is provided to support troubleshooting of the instrument.

TABLE 5-1. WATER FLOW RATES AND FREQUENCIES

Meter Size (inches)	K-Factor (nominal)	Flow Rate Limits (a)			Vortex Frequency (Hz)	
		Minimum (GPM)	Maximum (GPM) (c)	Max. Δp (psi)	Minimum	Maximum
1	80,000	3.6 (7.0) (b)	79	16.25	35.3	400
1.5	21,000	10.6	211	21.9	14.0	280
2	10,000	13.3	308	16.82	8.4	194.4
3	3,100	35.4	748	19.8	6.9	146.4
4	1,300	44.1	1,188	16.4	3.6	97.5
6	400	132	2,773	17.25	3.3	70
8	160	220	4,843	17.1	2.2	48.9
10	72	246	7,485	17.4	1.1	34
12	40	418	10,568	17.7	1.05	26.7

TABLE 5-2. AIR FLOW RATES AND FREQUENCIES

Meter Size (inches)	K-Factor (nominal)	Flow Rate Limits (ACFH)		Vortex Frequency (Hz)	
		Minimum	Maximum	Minimum	Maximum
1	80,000	343	2895	215.9	1,822
1.5	21,000	742	11310	122.6	1,868
2	10,000	1519	15891	119.5	1,250
3	3,100	2649	35314	64.6	861
4	1,300	4238	67098	43.3	686
6	400	8829	143023	27.8	450
8	160	8829	282520	11.1	355.6
10	72	28248	494340	16	280
12	40	49434	706200	15.6	222.2

TABLE 5-3. CONVERSION FACTORS

1 m ³ = 264.2 gallons
1 m ³ = 35.31 ft ³
1 gallon H ₂ O = 8.345 lbs
1 ft ³ H ₂ O = 62.42 lbs
Density of Air = 0.0749 lb/ft ³ @ 14.7 psia & 70°F

NOTE:

If meter is diagnosed as being defective and only the electronics (without the meter body) are being returned to the factory for repair or replacement, the following is an important procedure that should be performed prior to returning the electronics for repair.

The Analog Board (the PC board with the programming switches) contains a potentiometer (R312) to establish the signal "gain" or amplification value of the preamplifier circuitry. R312 is **calibrated at the factory under controlled flow conditions** to provide the optimum performance for the flowmeter in sensing the flow signal. If the meter's electronics are being returned to the factory for repair or replacement, a record should be kept of the value of this potentiometer setting. This allows establishing the same parameters when the equipment is returned and meter operation is restored.

To establish the calibrated value of R312, use the following procedure:

- Turn off power to the instrument.
- Remove the larger windowed top cover of the electronics compartment by removing the four bolts in the corners.
- Locate the Analog Board near the digital display of the lower Digital Board (The Analog Board contains the three banks of programming switches referenced in Sections 2.6 & 4.4).
- Locate potentiometer R312 on the Analog Board (It should be a blue or gray rectangular component with a small adjustment screw facing upward and is located in the left half of the board, about midway between top and bottom edges - Refer to Figure 2-7).
- Using a small fine-bladed screwdriver that fits the potentiometer's adjustment screw, turn the screw **counterclockwise** while counting the number of **full turns** made until a **faint clicking** is heard. This indicates the end of the potentiometer's adjustment range.
- Record the number of turns required to reach the end of R312's adjustment range (until the clicking is heard).

When the **replacement*** electronics are received and operation is to be restored, use the following procedure:

- Make certain power to the instrument is **OFF**.
- Make certain that potentiometer R312 is adjusted to its starting point by turning the adjusting screw fully counterclockwise several turns until the faint clicking is heard.
- Adjust R312's adjustment screw **clockwise** until the number of turns recorded in the above procedure is reached. This will insure that the operating conditions have been restored to their previous values.
- Replace the cover(s) for the instrument.
- Re-apply power to the meter.

*If a totally **new meter** is received as a replacement (meter body and electronics), is not necessary to perform this procedure since the meter will have been calibrated at the factory before shipment.

6.0 PARTS LIST

The following pages show a cutaway view of the flowmeter that indicates replacement parts that are available for the meter along with their Bailey-Fischer & Porter ordering numbers.

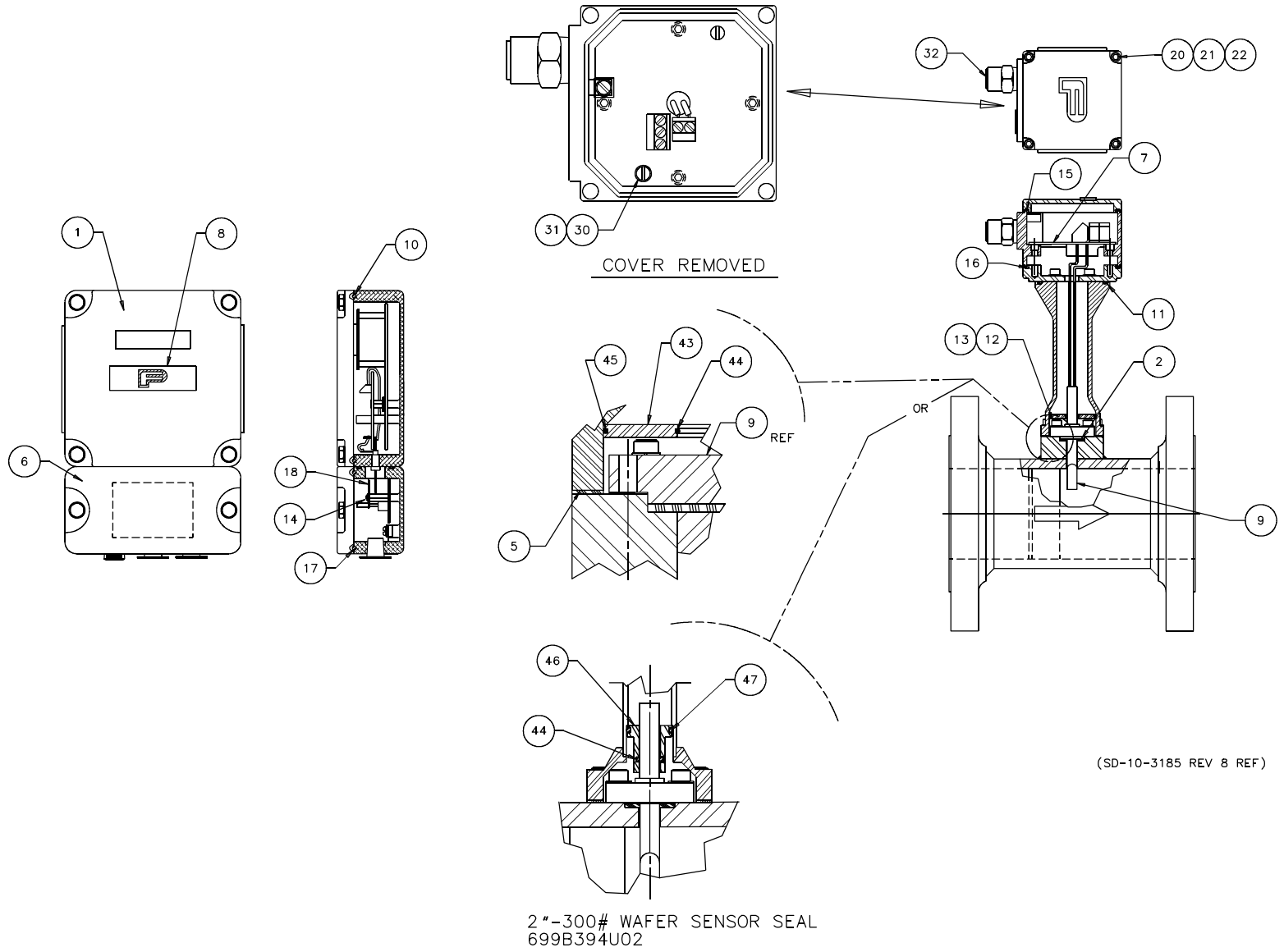

FIGURE 6-1. FLOWMETER / SIGNAL CONVERTER PARTS
(Refer to Table 6-1 for ordering information)

**TABLE 6-1. FLOWMETER / SIGNAL CONVERTER
PARTS LIST**

KEY	PART NUMBER	DESCRIPTION
1	D612A104U01	Cover with Window
2	D333C089U01	Graphite Gasket
	333C603U01	TEFLON Gasket
5	333G231U01	Gasket
6	D379D024U02	Connection Box Cover
7	D685A584U01	Two Wire Connection Board
8	D338A006U02	F&P Monogram
9	698B212U01	Sensor Ass'y (1 - 8 inch)
	698B212U02	Sensor Ass'y (10 & 12 inch)
10	D101A009U01	Gasket
11	101W937U01	VITON O-ring
12	09H112AU20	M5X16 Screw
13	85C024EU20	M5 Lockwasher
14	1D107B1004	Rivet
15	D333F008U01	Gasket
16	D333F009U01	Gasket
17	D333F004U01	Gasket
18	D355H162U04	STEP/DATA ID Plate
20	09G114AU20	M4X20 Screw
21	85C021EU20	Split Washer
22	101A701U01	Buna n O-ring
30	85G017HU20	M3 Lockwasher
31	02F106AU20	M3X16 Screw
32	132B020U01	Pressure Relief Valve
43	374A162U01	Sensor Seal
44	101S706U01	O-ring, Silicone (-011)
45	101S916U01	O-Ring, Silicone (-028)
46	374A162U02	Sensor Seal, 2"-300lb Wafer
47	101S903U01	O-Ring, Silicone
	614C019U01	Interface Cable Kit, 15 ft.
	614C019U02	Interface Cable Kit, 30 ft.

TABLE 6-2. FLANGE GASKETS

Meter Size		ANSI Flange Rating	Gasket Part Number (2) required
inches	mm		
1	25	150	333J089U10
		300	333J089U11
1.5	40	150	333J089U15
		300	333J089U16
2	50	150	333J089U19
		300	333J089U25
3	80	150	333J089U22
		300	333J089U26
4	100	150	333J089U29
		300	333J089U30
6	150	150	333J083U33
		300	333J083U42
8	200	150	333J083U38
		300	333J083U46
10	250	150	N/A
		300	N/A
12	300	150	N/A
		300	N/A

N/A = not available



DOCUMENTATION QUESTIONNAIRE

Your answers to the questions below and other comments assist us in publishing better documentation. If an answer requires explanation please use the space provided. All comments and suggestions become the property of Elsag Bailey Process Automation.

1. Title of Document? IB 10VR1000 - A.52 FIRMWARE, PN 24796

2. Does this document meet your needs? _____

3. Is the information:

Easily understandable? _____

Properly organized? _____

Complete? _____

Sufficiently illustrated? _____

OTHER COMMENTS

(Please include page and/or figure number.)

Name _____

Address _____

No postage necessary
if mailed in the U.S.A.

If Bailey employee, please include
department number.

CUT ALONG LINE, FOLD, STAPLE



FOLD 1



NO POSTAGE
NECESSARY
IF MAILED
IN THE
UNITED STATES

BUSINESS REPLY MAIL

FIRST CLASS PERMIT NO. 86 WARMINSTER, PA

POSTAGE WILL BE PAID BY ADDRESSEE:

**BAILEY-FISCHER & PORTER
DEPARTMENT 261 / A2
125 EAST COUNTY LINE ROAD
WARMINSTER, PA 18974**

Attention: Technical Publications

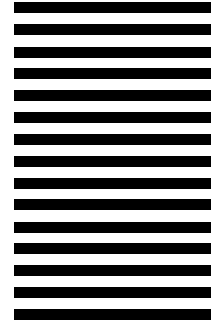

FOLD 2

STAPLE
HERE

Our more than 6,000 professionals worldwide are ready to meet your needs for Strategic Enterprise Management...

Bailey

Australia

Elsag Bailey Pty. Limited
Regents Park, NSW
Telephone: 61-2-645-3322
Telefax: 61-2-645-2212

Belgium

Bailey-Fischer & Porter NV
Wilrijk
Telephone: 32-3-828-05-11
Telefax: 32-3-827-87-28

Brazil

Bailey do Brasil
São Paulo
Telephone: 55-11-548-4122
Telefax: 55-11-547-0315

Canada

Elsag Bailey (Canada), Inc.
Burlington, Ontario
Telephone: 1-905-639-8840
Telefax: 1-905-639-8639

China

Bailey Beijing Controls
Beijing
Telephone: 86-10-401-0651
Telefax: 86-10-401-1643

Finland

Bailey-Fischer & Porter OY
Espoo
Telephone: 358-0-859-3133
Telefax: 358-0-859-3324

France

Elsag Bailey SA
Massy
Telephone: 33-1-64-47-2000
Telefax: 33-1-64-47-2016

Germany

Bailey-F & P Automation GmbH
Overath
Telephone: 49-220-473-90
Telefax: 49-220-473-979

Bailey-Fischer & Porter GmbH

Göttingen
Telephone: 49-551-905-0
Telefax: 49-551-905-777

Italy

Elsag Bailey
Genoa
Telephone: 39-10-658-1
Telefax: 39-10-658-2941

Italy

Fischer & Porter Division
Milan
Telephone: 39-2-927-71
Telefax: 39-2-923-1257

Japan

Bailey Japan Company, Ltd.
Tagata-Gun, Shizuoka-Ken
Telephone: 81-559-49-3311
Telefax: 81-559-49-1114

Jordan

Bailey Controls Jordan
Amman
Telephone: 962-6-788-116
Telefax: 962-6-756-908

Mexico

Bailey Mexico SA de CV
Naucalpan
Telephone: 52-5-557-6100
Telefax: 52-5-557-7022

Netherlands

Bailey-Fischer & Porter Nederland BV
Gorinchem
Telephone: 31-183-69-1111
Telefax: 31-183-69-1177

Norway

Bailey Norge AS
Bergen
Telephone: 47-55-222-000
Telefax: 47-55-222-010

Russia

Bailey Avtomatizatsiya
Moscow
Telephone: 7-502-224-8130
Telefax: 7-502-224-8145

Singapore

Elsag Bailey Pte. Ltd.
Singapore
Telephone: 65-442-3200
Telefax: 65-442-2700

Spain

Bailey-Fischer & Porter España SA
Madrid
Telephone: 34-1-415-2200
Telefax: 34-1-415-3950

Sweden

Bailey-Fischer & Porter Sverige AB
Stockholm
Telephone: 46-8-601-2850
Telefax: 46-8-601-2860

United Kingdom

Bailey Automation plc
Telford, Shropshire
Telephone: 44-1952-670-477
Telefax: 44-1952-670-455

Fischer & Porter Ltd.

Workington, Cumbria
Telephone: 44-1946-830-611
Telefax: 44-1946-833-003

United States

Bailey Controls Company
Wickliffe, Ohio
Telephone: 1-216-585-8500
Telefax: 1-216-585-8756

Bailey-Fischer & Porter Company

Warminster, Pennsylvania
Telephone: 1-215-674-6000
Telefax: 1-215-674-7183

Venezuela

Bailey de Venezuela SA
Valencia
Telephone: 58-41-329-196
Telefax: 58-41-327-632

Turbine Control Systems

Electronic Technology Systems, Inc.
New Kensington, Pennsylvania USA
Telephone: 1-412-335-1300
Telefax: 1-412-335-2450

Energy Management & SCADA Systems

Bailey Network Management
Sugar Land, Texas USA
Telephone: 1-713-274-5000
Telefax: 1-713-240-6986

Liquid Analysis Products

TBI-Bailey Controls
Carson City, Nevada USA
Telephone: 1-702-883-4366
Telefax: 1-702-883-4373

On-Line Process Analysis

Fluid Data, Inc.
Angleton, Texas USA
Telephone: 1-409-849-2344
Telefax: 1-409-849-2166

BAILEY
FISCHER
PORTER

TBI-Bailey



Bailey
Network Management

FLUID
DATA