

# INSTRUCTION MANUAL

E67-84-3B

Water & Industrial Analytics

Advantage Series Transmitter

Type TB84TE Two-Electrode Conductivity



---

The ABB logo, consisting of the letters "ABB" in a bold, red, sans-serif font.

**WARNING** notices as used in this manual apply to hazards or unsafe practices which could result in personal injury or death.

**CAUTION** notices apply to hazards or unsafe practices which could result in property damage.

**NOTES** highlight procedures and contain information which assist the operator in understanding the information contained in this manual.

#### **WARNING**

##### **INSTRUCTION MANUALS**

DO NOT INSTALL, MAINTAIN, OR OPERATE THIS EQUIPMENT WITHOUT READING, UNDERSTANDING AND FOLLOWING THE PROPER ABB INSTRUCTIONS AND MANUALS, OTHERWISE INJURY OR DAMAGE MAY RESULT.

##### **RADIO FREQUENCY INTERFERENCE**

MOST ELECTRONIC EQUIPMENT IS INFLUENCED BY RADIO FREQUENCY INTERFERENCE (RFI). CAUTION SHOULD BE EXERCISED WITH REGARD TO THE USE OF PORTABLE COMMUNICATIONS EQUIPMENT IN THE AREA AROUND SUCH EQUIPMENT. PRUDENT PRACTICE DICTATES THAT SIGNS SHOULD BE POSTED IN THE VICINITY OF THE EQUIPMENT CAUTIONING AGAINST THE USE OF PORTABLE COMMUNICATIONS EQUIPMENT.

##### **POSSIBLE PROCESS UPSETS**

MAINTENANCE MUST BE PERFORMED ONLY BY QUALIFIED PERSONNEL AND ONLY AFTER SECURING EQUIPMENT CONTROLLED BY THIS PRODUCT. ADJUSTING OR REMOVING THIS PRODUCT WHILE IT IS IN THE SYSTEM MAY UPSET THE PROCESS BEING CONTROLLED. SOME PROCESS UPSETS MAY CAUSE INJURY OR DAMAGE.

#### **NOTICE**

The information contained in this document is subject to change without notice.

ABB, its affiliates, employees, and agents, and the authors of and contributors to this publication specifically disclaim all liabilities and warranties, express and implied (including warranties of merchantability and fitness for a particular purpose), for the accuracy, currency, completeness, and/or reliability of the information contained herein and/or for the fitness for any particular use and/or for the performance of any material and/or equipment selected in whole or part with the user of/or in reliance upon information contained herein. Selection of materials and/or equipment is at the sole risk of the user of this publication.

This document contains proprietary information of ABB and is issued in strict confidence. Its use, or reproduction for use, for the reverse engineering, development or manufacture of hardware or software described herein is prohibited. No part of this document may be photocopied or reproduced without the prior written consent of ABB.



---

## List of Effective Pages

---

Total number of pages in this manual is 188, consisting of the following:

**Page No.**

**Change Date**

---

## Table of Contents

---

<b>SECTION 1 - INTRODUCTION</b>	1-1
OVERVIEW	1-1
INTENDED USER	1-2
FEATURES	1-2
EQUIPMENT APPLICATION	1-4
INSTRUCTION CONTENT	1-5
HOW TO USE THIS MANUAL	1-6
GLOSSARY OF TERMS AND ABBREVIATIONS	1-7
REFERENCE DOCUMENTS	1-9
NOMENCLATURE	1-10
SPECIFICATIONS	1-11
ACCESSORIES	1-14
<b>SECTION 2 - ANALYZER FUNCTIONALITY AND OPERATOR INTERFACE CONTROLS</b>	2-1
INTRODUCTION	2-1
ANALYZER OVERVIEW	2-1
USER INTERFACE	2-1
MODULAR ELECTRONIC ASSEMBLIES	2-2
TEMPERATURE COMPENSATION	2-2
ANALOG OUTPUTS	2-3
RELAY OUTPUTS	2-3
High or Low Set Point	2-3
High or Low Cycle Timer	2-4
Cleaner	2-5
DAMPING	2-5
DIAGNOSTICS	2-6
Analyzer	2-6
Sensor	2-6
Spike Output	2-7
<b>SECTION 3 - INSTALLATION</b>	3-1
INTRODUCTION	3-1
SPECIAL HANDLING	3-1
UNPACKING AND INSPECTION	3-2
LOCATION CONSIDERATIONS	3-3
HAZARDOUS LOCATIONS	3-3
RADIO FREQUENCY INTERFERENCE	3-3
MOUNTING	3-4
Pipe Mounting	3-4
Hinge Mounting	3-5
Wall Mounting	3-6
Panel Mounting	3-7
WIRING CONNECTIONS AND CABLING	3-9
Power Wiring	3-10
Analog Output Signal Wiring	3-11
Relay Output Signal Wiring	3-11

Two-Electrode Sensor Wiring . . . . .	3-13
GROUNDING . . . . .	3-14
OTHER EQUIPMENT INTERFACE . . . . .	3-15
INSTRUMENT ROTATION . . . . .	3-15
<b>SECTION 4 - OPERATING PROCEDURES . . . . .</b>	<b>4-1</b>
INTRODUCTION . . . . .	4-1
OPERATOR INTERFACE CONTROLS REVIEW . . . . .	4-1
Liquid Crystal Display (LCD) . . . . .	4-1
Multi-Function Smart Keys . . . . .	4-3
MODES OF OPERATION . . . . .	4-5
HOLD ICON . . . . .	4-6
FAULT ICON . . . . .	4-6
SPIKE ICON . . . . .	4-7
RELAY ICONS . . . . .	4-7
<b>SECTION 5 - MEASURE MODE . . . . .</b>	<b>5-1</b>
INTRODUCTION . . . . .	5-1
BOREDOM SWITCH . . . . .	5-1
PRIMARY DISPLAY . . . . .	5-1
SECONDARY DISPLAY . . . . .	5-2
FAULT INFORMATION Smart Key . . . . .	5-2
SPT Smart Key . . . . .	5-2
MENU Smart Key . . . . .	5-3
<b>SECTION 6 - CALIBRATE MODE . . . . .</b>	<b>6-1</b>
INTRODUCTION . . . . .	6-1
CALIBRATE STATES OF OPERATION . . . . .	6-1
Conductivity/Concentration Calibrate State . . . . .	6-3
Temperature Calibrate State . . . . .	6-5
Edit Calibrate State . . . . .	6-7
Reset Calibrate State . . . . .	6-8
Analog Output One & Two Calibrate State . . . . .	6-9
<b>SECTION 7 - OUTPUT/HOLD MODE . . . . .</b>	<b>7-1</b>
INTRODUCTION . . . . .	7-1
OUTPUT/HOLD STATES OF OPERATION . . . . .	7-1
Hold/Release Hold Output State . . . . .	7-2
Analog Output One Rerange State . . . . .	7-6
Analog Output Two Rerange State . . . . .	7-7
Damping State . . . . .	7-8
Spike State . . . . .	7-10
<b>SECTION 8 - CONFIGURE MODE . . . . .</b>	<b>8-1</b>
INTRODUCTION . . . . .	8-1
PRECONFIGURATION DATA REQUIRED . . . . .	8-1
CONFIGURE VIEW/MODIFY STATE . . . . .	8-1
BASIC/ADVANCED PROGRAMMING MODE . . . . .	8-3
MODIFY CONFIGURE STATES OF OPERATION . . . . .	8-4
Analyzer State (Basic/Advanced) . . . . .	8-8

Conductivity Analyzer State (Basic/Advanced) . . . . .	8-8
Concentration State (Advanced) . . . . .	8-9
Temperature Sensor State (Basic/Advanced) . . . . .	8-13
Temperature Compensation State (Basic/Advanced) . . . . .	8-13
Analog Output One State (Basic/Advanced) . . . . .	8-18
Linear Output State (Basic/Advanced) . . . . .	8-18
Non-Linear Output State (Advanced) . . . . .	8-20
Analog Output Two State (Basic/Advanced) . . . . .	8-22
Relay Output One (Basic/Advanced) . . . . .	8-24
Relay Output Two (Basic/Advanced) . . . . .	8-25
Relay Output Three (Basic/Advanced) . . . . .	8-27
Setpoint Relay Output (Basic/Advanced) . . . . .	8-28
Diagnostic Relay Output (Basic/Advanced) . . . . .	8-30
Cycle Timer Relay Output (Advanced) . . . . .	8-31
Cleaner Relay Output (Advanced) . . . . .	8-33
Damping State (Basic/Advanced) . . . . .	8-35
Diagnostics State (Basic/Advanced) . . . . .	8-37
Safe Mode One State (Basic/Advanced) . . . . .	8-37
Safe Mode Two State (Basic/Advanced) . . . . .	8-38
Spike State (Advanced) . . . . .	8-38
CONFIGURATION LOCKOUT . . . . .	8-39

<b>SECTION 9 - SECURITY MODE . . . . .</b>	<b>9-1</b>
INTRODUCTION . . . . .	9-1
SECURITY STATE OF OPERATION . . . . .	9-1

<b>SECTION 10 - SECONDARY DISPLAY MODE . . . . .</b>	<b>10-1</b>
INTRODUCTION . . . . .	10-1
SECONDARY DISPLAY STATE OF OPERATION . . . . .	10-1

<b>SECTION 11 - SETPOINT/TUNE MODE . . . . .</b>	<b>11-1</b>
INTRODUCTION . . . . .	11-1
SETPOINT/TUNE STATES OF OPERATION . . . . .	11-1
Setpoint Relay Output (Basic/Advanced) . . . . .	11-1
Diagnostic Relay Output (Basic/Advanced) . . . . .	11-3
Cycle Timer Relay Output (Advanced) . . . . .	11-4
Cleaner Relay Output (Advanced) . . . . .	11-6

<b>SECTION 12 - UTILITY MODE . . . . .</b>	<b>12-1</b>
INTRODUCTION . . . . .	12-1
FACTORY/USER STATE . . . . .	12-1
User State . . . . .	12-1
Advanced/Basic Programming Mode User State . . . . .	12-2
Reset Configuration User State . . . . .	12-3
Reset Security User State . . . . .	12-4
Reset All User State . . . . .	12-5
Soft Boot User State . . . . .	12-6

<b>SECTION 13 - DIAGNOSTICS . . . . .</b>	<b>13-1</b>
INTRODUCTION . . . . .	13-1

---

FAULT CODES . . . . .	13-1
Problem Codes . . . . .	13-2
Error Codes . . . . .	13-4
Calibration Diagnostic Messages . . . . .	13-5
Additional Diagnostic Messages . . . . .	13-6
<b>SECTION 14 - TROUBLESHOOTING . . . . .</b>	<b>14-1</b>
INTRODUCTION . . . . .	14-1
ANALYZER TROUBLESHOOTING . . . . .	14-1
INSTRUMENT TROUBLESHOOTING . . . . .	14-4
Instrument Electronic Test . . . . .	14-4
SENSOR TROUBLESHOOTING . . . . .	14-5
Visual Sensor Inspection . . . . .	14-6
Sensor Electronic Test . . . . .	14-6
<b>SECTION 15 - MAINTENANCE . . . . .</b>	<b>15-1</b>
INTRODUCTION . . . . .	15-1
PREVENTIVE MAINTENANCE . . . . .	15-1
Cleaning the Sensor . . . . .	15-2
<b>SECTION 16 - REPLACEMENT PROCEDURES . . . . .</b>	<b>16-1</b>
INTRODUCTION . . . . .	16-1
ELECTRONIC ASSEMBLY REMOVAL/REPLACEMENT . . . . .	16-1
FRONT BEZEL ASSEMBLY REMOVAL/REPLACEMENT . . . . .	16-2
SHELL ASSEMBLY REMOVAL/REPLACEMENT . . . . .	16-2
REAR COVER ASSEMBLY REMOVAL/REPLACEMENT . . . . .	16-3
<b>SECTION 17 - SUPPORT SERVICES . . . . .</b>	<b>17-1</b>
INTRODUCTION . . . . .	17-1
RETURN MATERIALS PROCEDURES . . . . .	17-1
REPLACEMENT PARTS . . . . .	17-1
RECOMMENDED SPARE PART KITS . . . . .	17-2
<b>APPENDIX A - TEMPERATURE COMPENSATION . . . . .</b>	<b>A-1</b>
GENERAL . . . . .	A-1
CONDUCTIVITY AND CONCENTRATION ANALYZER . . . . .	A-1
PURE WATER TEMPERATURE COMPENSATION . . . . .	A-3
<b>APPENDIX B - CONCENTRATION PROGRAMMING . . . . .</b>	<b>B-1</b>
GENERAL . . . . .	B-1
USER PROGRAMMED CONCENTRATION TO CONDUCTIVITY CURVES . . . . .	B-1
<b>APPENDIX C - PROGRAMMING TEXT STRING GLOSSARY . . . . .</b>	<b>C-1</b>
GENERAL . . . . .	C-1
GLOSSARY OF PROGRAMMING TEXT PROMPTS . . . . .	C-1
<b>APPENDIX D - CONFIGURATION WORKSHEETS . . . . .</b>	<b>D-1</b>

---

## Safety Summary

---

**GENERAL  
WARNINGS****Equipment Environment**

All components, whether in transportation, operation or storage, must be in a noncorrosive environment.

**Electrical Shock Hazard During Maintenance**

Disconnect power or take precautions to insure that contact with energized parts is avoided when servicing.

**SPECIFIC  
CAUTIONS**

To prevent possible signal degradation, separate metal conduit runs are recommended for the sensor, signal and power wiring.

---

**SPECIFIC  
WARNINGS**

Use this equipment only in those classes of hazardous locations listed on the nameplate. Uses in other hazardous locations can lead to unsafe conditions that can injure personnel and damage equipment.

Allow only qualified personnel (refer to INTENDED USER in SECTION 1 - INTRODUCTION) to commission, operate, service or repair this equipment. Failure to follow the procedures described in this instruction or the instructions provided with related equipment can result in an unsafe condition that can injure personnel and damage equipment.

Consider the material compatibility between cleaning fluids and process liquids. Incompatible fluids can react with each other causing injury to personnel and equipment damage.

Use solvents only in well ventilated areas. Avoid prolonged or repeated breathing of vapors or contact with skin. Solvents can cause nausea, dizziness, and skin irritation. In some cases, overexposure to solvents has caused nerve and brain damage. Solvents are flammable - do not use near extreme heat or open flame.

Do not substitute components that compromise the certifications listed on the nameplate. Invalidating the certifications can lead to unsafe conditions that can injure personnel and damage equipment.

Do not disconnect equipment unless power has been switched off at the source or the area is known to be nonhazardous. Disconnecting equipment in a hazardous location with source power on can produce an ignition-capable arc that can injure personnel and damage equipment.

Remove power from the unit and allow at least one minute for the unit to discharge before performing these procedures. Failure to do so constitutes an electrical shock hazard that can injure personnel and damage equipment.

Disconnect the AC line cord or power lines from the operating branch circuit coming from the source before attempting electrical connections. Instruments powered by AC line voltage constitute a potential for personnel injury due to electric shock.

Keep the enclosure and covers in place after completing the wiring procedures and during normal operation. Do not disconnect or connect wiring or remove or insert printed circuit boards unless power has been removed and the flammable atmosphere is known NOT to be present. These procedures are not considered normal operation. The enclosure prevents operator access to energized components and to those that can cause ignition capable arcs. Failure to follow this warning can lead to unsafe conditions that can injure personnel and damage equipment.

All error conditions are considered catastrophic. When such an error has been reported, the analyzer should be replaced with a known-good analyzer. The non-functional analyzer should be returned to the factory for repair. Contact the factory for a Return Materials Authorization (RMA) number.

---

## SECTION 1 - INTRODUCTION

---

### OVERVIEW

The TB84TE Series is a line-powered conductivity/concentration analyzer with state-of-the-art electronics, internal and external diagnostic functionality, an innovative user-interface having *HotKey* capability, two user-selectable modes of operation, and DIN-size packaging.

Diagnostic interrogation of the internal circuitry and external sensing devices is continually conducted to ensure accuracy and immediate notification of problem situations when they occur. Detection of sensor integrity includes sensor polarization and performance. Additional software functions monitor slope, offset, process variable over/under range, and temperature over/under range. If a diagnostic condition occurs, the analyzer can be programmed to induce a repetitive modulation of a given magnitude in the output current or can be link to a relay output thus providing the ability to alert personnel of a problem condition.

The analyzer packaging conforms to DIN standards and has mounting options that include pipe, wall, hinge, and panel installations. Due to the modular design of the electronics, changing the analyzer sensing capability to other analytical properties such as four-electrode conductivity can be quick and easy.

The user interface is an innovative, patented technology that facilitates a smooth and problem-free link between the user and analyzer functionality. The programming structure and multi-function keys reduce programming difficulties by providing a toggle between *Basic* and *Advanced* functions.

---

**INTENDED USER**

<b>Installation Personnel</b>	Should be an electrician or a person familiar with the National Electrical Code (NEC), or equivalent, and local wiring regulations. Should have a strong background in installation of analytical equipment.
<b>Application Technician</b>	Should have a solid background in conductivity and/or concentration measurements, electronic instrumentation, and process control and be familiar with proper grounding and safety procedures for electronic instrumentation.
<b>Operator</b>	Should have knowledge of the process and should read and understand this instruction manual before attempting any procedure pertaining to the operation of the TB84TE Series analyzer.
<b>Maintenance Personnel</b>	Should have a background in electricity and be able to recognize shock hazards. Personnel must also be familiar with electronic process control instrumentation and have a good understanding of troubleshooting procedures.

---

**FEATURES**

<b>Diagnostic Sensor Capability</b>	The TB84TE Series analyzer offers the necessary hardware and software for full compatibility with TB2 Series Conductivity Sensors and three different types of Resistive Temperature Devices. Diagnostic capability includes polarization, process and temperature variable over/under range conditions.
<b>Multiple Applications</b>	Accepts inputs from all ABB two-electrode conductivity sensors. Isolated analog outputs allow use in grounded or floating circuits. Relay outputs provide setpoint control, cycle-timer control, diagnostic alarming, and cleaner operation.

---

**Automatic Temperature Compensation**

Menu-selectable choices provide the user with a wide range of easily configurable selections for temperature compensation.

1. Manual (0.1N KCl based)
2. Automatic based on either:
  - a) Standard (0.1N KCl based)
  - b) Coefficient (0 to 9.99%/°C adjustable)
  - c) Pure Water - Neutral Salt
  - d) Pure Water - Acid
  - e) Pure Water - Base
  - f) User-Defined

**Wide Rangeability**

Analog output spans do not affect the display range of 0.000  $\mu\text{S}/\text{cm}$  to 19.99  $\text{mS}/\text{cm}$  for Conductivity and 0 to 1999 digits, specified in the configured Engineering Units, for Concentration. Minimum and maximum output spans for nominal cell constant values are 100  $\mu\text{S}/\text{cm}$  and 19.99  $\text{mS}/\text{cm}$  for 1.0  $\text{cm}^{-1}$ , 10  $\mu\text{S}/\text{cm}$  and 1999  $\mu\text{S}/\text{cm}$  for 0.1  $\text{cm}^{-1}$ , and 1  $\mu\text{S}/\text{cm}$  and 199.9  $\mu\text{S}/\text{cm}$  for 0.01  $\text{cm}^{-1}$ , respectively. Minimum and maximum temperature output spans are 10 °C (18° F) and 200 °C (392 °F), respectively.

**Innovative User Interface**

Using four Smart Keys and a custom Liquid Crystal Display (LCD), multiple functions have been assigned to each key and are displayed at the appropriate time depending on the programming environment. This patented technology reduces the number of keys while maintaining the maximum amount of functionality and allows for the use of a larger, more visible LCD.

**Simple Calibration**

One-point smart calibration routines for the process variable and temperature automatically determine the appropriate adjustment of sensor gain (i.e., slope) or offset. Provisions for viewing and modifying the sensor calibration data are also included.

**NEMA 4X/IP65 Housing**

Suitable for corrosive environments, the electronics enclosure is a corrosion resistant, aluminum alloy. A chemical resistant polyester powder coating provides external protection.

---

<b>Suitable for Hazardous Locations</b>	The TB84TE Series analyzer design complies with industry standards for Division 2 and non-incendive installations.
<b>Diagnostic Indication</b>	The custom LCD has dedicated icons that act as visible indications of an output hold, fault, diagnostic spike, and energized relay condition.
<b>Secure Operation</b>	A hardware lockout feature prevents unauthorized altering of instrument configuration parameters while allowing other analyzer functions to be fully accessible. Software security codes can also be assigned to the Configure, Calibrate, Output/Hold, and Setpoint/Tune Modes of Operation.
<b>Compact Packaging</b>	Industry standard ½-DIN size maintains standard panel cut-outs and increases installation flexibility by providing pipe, wall, hinge, and panel mounting options.
<b>Nonvolatile Memory</b>	In the event of a power failure, the nonvolatile memory stores and retains the configuration and calibration data.
<b>Analyzer Diagnostics</b>	Built-in electronic circuitry and firmware routines perform a series of self-diagnostics, monitoring such areas as memory and input circuit integrity. Irregularities are indicated for maintenance purposes.

---

## **EQUIPMENT APPLICATION**

The TB84TE Series analyzer can be used anywhere conductivity or concentration measurements are desired.

---

## INSTRUCTION CONTENT

---

<b>Introduction</b>	This section provides a product overview, a description of each section contained in this manual, and how each section should be used. This section also has a glossary of terms and abbreviations, a list of reference documents on related equipment and/or subjects, the product identification (nomenclature), and a comprehensive list of hardware performance specifications, accessories part numbers, and applicable certification information.
<b>Analyzer Functionality And Operator Interface Controls</b>	This section provides a short description on the functionality of the TB84TE Series analyzer.
<b>Installation</b>	This section provides information on analyzer installation such as unpacking directions, location considerations, analyzer mounting options and procedures, wiring instructions, sensor connections, and grounding procedures.
<b>Operating Procedures</b>	This section addresses the operator interface controls and their function. The Modes of Operation and LCD status icons are listed and their functions are described.
<b>Measure Mode</b>	This section describes the normal analyzer mode of operation which includes the primary and secondary display, Fault Information Smart Key, and Menu Smart Key functions.
<b>Calibrate Mode</b>	This section provides sensor and analyzer calibration procedures and calibration data descriptions.
<b>Output/Hold Mode</b>	This section describes the Output/Hold States of Operation including hold, rerange, damping, and spike features.
<b>Configure Mode</b>	This section defines the required actions to establish and program the analyzer configuration.
<b>Security Mode</b>	This section provides the procedures necessary to set and clear analyzer security codes.

---

<b>Secondary Display Mode</b>	This section provides the procedure necessary to set the information displayed in secondary display of the Measure Mode.
<b>Utility Mode</b>	This section defines the reset options and Basic/Advanced programming toggle.
<b>Diagnostics</b>	This section provides a description of the diagnostic tools available to aid with analyzer servicing. This section also provides a listing of displayed faults and the corrective actions.
<b>Troubleshooting</b>	This section provides an analyzer and sensor troubleshooting guide to help determine and isolate problems.
<b>Sensor Maintenance</b>	This section provides cleaning procedures for conductivity sensors.
<b>Repair/Replacement</b>	This section includes procedures for analyzer assembly and sensor replacement.
<b>Support Services</b>	This section provides a list of replacement parts unique to the TB84TE Series analyzer.
<b>Appendix A</b>	This section provides temperature compensation information.
<b>Appendix B</b>	This section provides concentration configuration information.
<b>Appendix C</b>	This section provides a glossary of text prompts used in the secondary display during analyzer programming.
<b>Appendix D</b>	This section provides a configuration worksheet used to record the analyzer's configuration and shows default values when a configuration reset is performed.

---

## HOW TO USE THIS MANUAL

For safety and operating reasons, reading and understanding this product instruction manual is critical. Do not install or complete any tasks or procedures related to operation until doing so.

The sections of this product instruction are sequentially arranged as they relate to initial start-up (from UNPACKING to REPAIR/REPLACEMENT PROCEDURES). After initial start-up, refer to this instruction as needed by section.

## GLOSSARY OF TERMS AND ABBREVIATIONS

Table 1-1. Glossary of Terms and Abbreviations

Term	Description
<b>Analog</b>	Continuously variable as opposed to discretely variable.
<b>Boredom Switch</b>	An automatic timer built into the TB84TE Series analyzer that returns the instrument to the Measure Mode of Operation if a user has entered another mode of operation and has not initiated another action for twenty minutes.
<b>CC</b>	Sensor Cell Constant.
<b>Conductivity</b>	Term derived from Ohm's Law that is defined as <b>E=IR</b> . When voltage <b>E</b> is connected across an electric conductor, electric current <b>I</b> will flow that is dependent on the resistance <b>R</b> of the conductor. Conductivity is the reciprocal of resistance.
<b>Control Output</b>	The control system signal that influences the operation of a final control element.
<b>Damping</b>	Damping time described as a lag.
<b>Digital</b>	A discretely variable signal usually having only two states, on or off.
<b>EEPROM</b>	Electrically Erasable Programmable Read Only Memory. A type of non-volatile memory that is electrically programmed and erased.
<b>EPROM</b>	Erasable Programmable Read Only Memory. This memory holds the operational program for the microcontroller integral to the analyzer.
<b>EU</b>	Engineering Unit. A set of units that define the numeric variable (e.g., ppm, %, TDS, etc.).
<b>FS</b>	Full Scale. The maximum allowable range specified for a given piece of equipment.

<b>Term</b>	<b>Description</b>
<b>Ground Loop</b>	A path between two separate ground connections thus allowing unwanted current flow through the measurement cabling or circuitry.
<b>HotKey</b>	A short-cut that moves the user from the View Configure State to the Modify Configure State of Operation.
<b>Icon</b>	A text or symbolic image representing a set function, condition, or engineering unit.
<b>LCD</b>	Liquid Crystal Display. The custom three-and-one-half digit primary display, six-character alpha-numeric secondary field, and supporting icons that allow for local readout of the process variable, programming of analyzer functions, and local indication of fault, hold, and relay state conditions.
<b>Loop</b>	That portion of an analog process control loop that resides within the analyzer. It typically consists of an analog input measuring the process variable and an analog output driving a final control element or data recorder.
<b>LSD</b>	Least Significant Digit.
<b>µS/cm</b>	Unit of conductivity, microsiemens per centimeter or $10^{-6}$ siemens/cm (equivalent to 1 micromho/cm).
<b>mS/cm</b>	Unit of conductivity, millisiemens per centimeter or $10^{-3}$ siemens/cm (equivalent to 1 millimho/cm)
<b>Non-volatile Memory</b>	Memory that retains programmed information such as configuration and calibration parameters, even when power is removed.
<b>PCB</b>	Printed Circuit Board. A flat board that contains pads for integrated circuit chips, components, connections, and electrically conductive pathways between those elements that function together to form an electronic circuit.
<b>Process Variable (PV)</b>	Temperature compensated conductivity, concentration, or temperature, depending on the configured analyzer options.

<b>Term</b>	<b>Description</b>
<b>RTD</b>	Resistive Temperature Detector. An element whose resistance has a relationship with the temperature of its surroundings.
<b>SEEPROM</b>	Serial Electrically Erasable Programmable Read Only Memory. A type of non-volatile memory that can be electrically programmed, erased, and read using serial communication techniques.
<b>Slope</b>	The linear relation between two sets of variables that describes the rate of change between these variables.
<b>Solution Coefficient</b>	A method of temperature compensation that assumes a constant change in solution conductivity relative to temperature. The units are in percentage of conductivity per °C.
<b>SPDT</b>	Single Pole, Double Throw.
<b>SSD</b>	Static Sensitive Device.
<b>Temperature Compensation</b>	Correcting a process variable for the effects of temperature.

#### REFERENCE DOCUMENTS

Table 1-2. Reference Documents

<b>Number</b>	<b>Document</b>
E67-23-1	Conductivity Sensors for Process Monitoring
Contact Factory	TB84TE Series Product Specification

**NOMENCLATURE**

Position	5	6	7	8	9	10	11	12	13	
Type	TB84									<b>Advantage Series Analyzer</b>
										<b>Input</b>
	P	H								pH/ORP/pION
	E	C								Four-Electrode Conductivity
	T	E								Two-Electrode Conductivity
	T	C								Toroidal Conductivity
										<b>Programming</b>
			1							Basic
			2							Advanced
										<b>Reserved (PI Controller)</b>
			0							None
										<b>Reserved (Remote Analyzer)</b>
				0						None
										<b>Housing Type</b>
						0				Powder Coated, Anodized
										Aluminum
										<b>Mounting Hardware</b>
							0			None
							1			Pipe
							2			Hinge
							3			Panel
							4			Wall
										<b>Agency Approval</b>
								0		None
								1		FM
								2		CSA
										<b>Label</b>
								0		None
								1		Stainless Steel
								2		Mylar

NOTE: A single digit or letter must be used in each nomenclature position.

## SPECIFICATIONS

Table 1-3. Specifications

Property	Characteristic/Value
Process Display Range Conductivity Concentration	0.000 $\mu\text{S}/\text{cm}$ to 19.99 $\text{mS}/\text{cm}$ (Temperature Compensated) 0.000 to 1999 digits (EU Configurable)
Temperature Display Range	-20° to 300°C (-4° to 572°F).
Sensor Full Scale Measurement Ranges (Nominal CC Values)	Cell Constant 1.0 $\text{cm}^{-1}$ - 0 to 19.99 $\text{mS}/\text{cm}$ Cell Constant 0.1 $\text{cm}^{-1}$ - 0 to 1999 $\mu\text{S}/\text{cm}$ Cell Constant 0.01 $\text{cm}^{-1}$ - 0 to 199.9 $\mu\text{S}/\text{cm}$
Resolution, Display Conductivity (Nominal CC Values)  Concentration Temperature	Cell Constant 1.0 $\text{cm}^{-1}$ : 0.1 $\mu\text{S}/\text{cm}$ Cell Constant 0.1 $\text{cm}^{-1}$ : 0.01 $\mu\text{S}/\text{cm}$ Cell Constant 0.01 $\text{cm}^{-1}$ : 0.001 $\mu\text{S}/\text{cm}$ 0.001 Digits (Configuration Dependent) 1°C, 1°F.
Accuracy, Display Conductivity Temperature	$\pm 1.0\%$ of Measurement Decade 1°C
Accuracy, Output	$\pm 0.02$ mA For An Output Range Set To FS Values <sup>1</sup>
Nonlinearity, Display Conductivity Temperature	$\pm 1.0\%$ of Measurement Decade 1°C
Nonlinearity, Output	$\pm 0.02$ mA For An Output Range Set To FS Values
Repeatability, Display Conductivity Temperature	$\pm 1.0\%$ of Measurement Decade 1°C
Repeatability, Output	$\pm 0.02$ mA For An Output Range Set To FS Values
Stability, Display Conductivity Temperature	$\pm 2$ LSD Typical; 5 LSD Maximum 1°C
Stability, Output	$\pm 0.01$ mA For An Output Range Set To FS Values
Temperature Compensation	Manual (0.1N KCl based) Automatic - Configurable as: Standard (0.1N KCl based) Coefficient (0 to 9.99%/°C adjustable) Pure Water - Neutral Salt Pure Water - Acid Pure Water - Base User-Defined

<sup>1</sup>Not applicable below 0.2 mA for 0 to 20 mA setting.

Property	Characteristic/Value
Input Types Conductivity Concentration Temperature	ABB Two-Electrode Conductivity Sensors ABB Two-Electrode Conductivity Sensors 3 kohm Balco, Pt100, Pt1000
Dynamic Response	3 sec. for 90% step change at 0.0 sec. damping.
Ambient Temperature Effect Conductivity Output	±0.015%/°C FS @ 95% Relative Humidity ±0.05%/°C Displayed Value @ 95% Relative Humidity ±0.002 mA/°C @ 95% Relative Humidity
Output Minimum Span Conductivity Concentration Temperature	Cell Constant 1.0 cm <sup>-1</sup> : 100.0 µS/cm Cell Constant 0.1 cm <sup>-1</sup> : 10.00 µS/cm Cell Constant 0.01 cm <sup>-1</sup> : 1.000 µS/cm 5% Maximum Concentration Range 10 °C (18 °F)
Output Maximum Span (full scale settings) Conductivity Concentration Temperature	Cell Constant 1.0 cm <sup>-1</sup> : 19.99 mS/cm Cell Constant 0.1 cm <sup>-1</sup> : 1999 µS/cm Cell Constant 0.01 cm <sup>-1</sup> : 199.9 µS/cm 1999 Digits 300 °C, 540 °F (-20 to 300 °C, -4 to 572 °F)
Damping	Continuously adjustable from 0.0 to 99.9 seconds
Supply Voltage Ranges	93.5 to 276 Vac, 50 to 60 Hz, Single Phase Maximum Consumption 17 VA
Analog Output Ratings	Two completely isolated 0/4 to 20 mAdc outputs 750 ohms Maximum Load Value Output One Fixed to the Process Variable Output Two Software-Selectable to either the Process Variable or Temperature
Relay Output Ratings	Three SPDT contacts with LCD icon indicators Hardware configurable for Normally Open or Normally Closed Operation Software configurable relay functions include High/Low Setpoint with adjustable Deadband and Time Delay, High/Low Cycle Timer with adjustable Duty Cycle and Time Delay, Diagnostic Alarm, and Cleaner Control Maximum AC Capacity Values of 100 VA, 240 Vac, and 3 A Maximum DC Capacity Values of 50 W, 24 Vdc, and 3 A
Power Supply Effect	±0.005% of full scale span per volt
Turn-On Time	2 seconds typical, 4 seconds maximum
Maximum Sensor Cable Length	100 ft (30.5 m)
Sensor Diagnostic	Polarization, PV/Temperature Over/Under Range, Slope and Offset Check

Property	Characteristic/Value
Diagnostic Notification Analog Mode	Local indication via a FAULT and SPIKE icon. Programmable output pulse on Analog Output One, 0 to 16 mA for 1 seconds on 6 second cycles
Environmental Operating temperature LCD Range Storage temperature	-20° to 60°C (-4° to 140°F) -20° to 60°C (-4° to 140°F) -40° to 70°C (-40° to 158°F)
Mounting Effect	None
Enclosure Classification	NEMA 4X IP65
Size Height Minimum panel depth Maximum panel cutout	144 mm high x 144 mm wide x 171 mm long (5.67 in. high x 5.67 in. wide x 6.75 in. long) 145 mm (5.70 in.) 136.7 mm x 136.7 mm (5.38 in. x 5.38 in.).
Weight	4.2 lb (1.9 kg) without mounting hardware 7.5 lb (3.4 kg) with Pipe Mounting Hardware
EMC Requirements (pending)	CE certified: Electromagnetic Emission - EN50081-2: 1994 EN55011: 1991 (CISPR11: 1990) Class A Electromagnetic Immunity - EN50082-2: 1996 EN61000-4-2: 1995 4 kV Contact 4 kV Indirect EN61000-4-3: 1997 10 V/m (unmodulated, rms) 80 to 1000 MHz EN61000-4-4: 1995 1 kV Signal Lines 5/50 T <sub>r</sub> /T <sub>n</sub> nS 5 kHz EN61000-4-8: 1994 50 Hz 30A(rms)/m ENV50141: 1994 10 V (unmodulated, rms) 0.15 to 80 MHz 80% AM (1kHz) 150 ohms, source impedance ENV50204: 1996 10 V/m (unmodulated, rms) 900 ±5 MHz 50% duty cycle 200 Hz Low Voltage - EN61010-1:1993 (Category II)
Agency Approvals <sup>1</sup> FM  CSA	Non-incendive. Class I, Division 2, Groups A, B, C, and D. Class II, Division 2, Groups F and G. Class III, Division 2.  Class I, Division 2, Groups A, B, C, and D. Class II, Division 2, Groups E, F and G. Class III, Division 2.

**SPECIFICATIONS SUBJECT TO CHANGE WITHOUT NOTICE**

1. Hazardous location approvals for use in flammable atmospheres are for ambient conditions of -25° to 40°C (-13° to 104°F), 86 to 108kPa (12.5 to 15.7 psi) with a maximum oxygen concentration of 21%.

---

**ACCESSORIES**
**Kits**

Part Number	Mounting Kit
4TB9515-0124	Pipe
4TB9515-0125	Hinge
4TB9515-0156	Wall
4TB9515-0123	Panel

Part Number	Description
4TB9515-0163	½" Cord Grip Fitting
4TB9515-0165	½" Cord Grip Fitting
4TB9515-0191	PG9 Cord Grip Fitting
4TB9515-0198	Complete Cord Grip Set (Three PG9 p/n 4TB9515-0191 & Two ½" p/n 4TB9515-0165)

See Section 17, Support Services, for a complete list of available kits.

**Sensors**

Nomenclature	Cell Constant	Fitting Type
TB25	0.01	316 Stainless Steel Tri-Clamp Sanitary/Sterilizable
	0.1	
	1.0	
TB254	0.01	In-line Twist Lock, Submersible
	0.1	
	1.0	
TB256	0.01	In-line Threaded, Submersible
	0.1	
	1.0	
TB26	0.01	In-line Threaded, Submersible Ball Valve Insertion, Hot Tap
	0.1	
	1.0	
TB264	0.01	25 mm Port, Sanitary
	0.1	
	1.0	
TB27	0.01	High Pressure Hot Tap
	0.1	
	1.0	
TB28	0.01	316 Stainless Steel Tri-Clamp Sterilizable
	0.1	
	1.0	

---

## SECTION 2 - ANALYZER FUNCTIONALITY AND OPERATOR INTERFACE CONTROLS

---

### INTRODUCTION

The beginning of this section contains an overview of the TB84TE Two-Electrode Conductivity Series analyzer functionality and important information for configuration personnel. The latter part of this section discusses the operator interface controls. It includes descriptions of the analyzer modes and faceplate controls.

---

### ANALYZER OVERVIEW

The TB84TE Series analyzer provides two analog output signals that can be configured to the solution conductivity and temperature as measured by the analyzer and sensor. In addition to the two analog outputs, three integral relay outputs can be configured as a high or low setpoint controller, cycle-timer controller, diagnostic alarm, or cleaner controller.

The analyzer is equipped with internal diagnostic capabilities allowing for the detection of any potential problems with the electronics and operation of firmware. Diagnostic capability also includes the detection of sensor integrity such as polarization, process variables out of range, and incorrect calibration values.

---

### USER INTERFACE

The user interface consists of a tactile keypad having four Smart keys, one hidden key, and a custom LCD. The LCD has a three and one-half digit numeric region that displays the process variable, a six-digit alphanumeric region that displays secondary information and programming prompts, and several status-indicating and programming icons.

---

Using a patented technique, each of the four keys is located under a given set of icons. In each of the instrument modes and mode states, one icon over any given key will be illuminated and will represent that key's function. These Smart Key assignments will vary as the user enters into different programming modes and states. In addition to the Smart Key assignments, text strings located in the six character alphanumeric field (i.e., secondary display) are used as programming prompts. The end result is an interface that provides a great deal of flexibility and functionality.

---

### **MODULAR ELECTRONIC ASSEMBLIES**

The TB84TE Series analyzer consists of three separate PCB assemblies that concentrate specific circuit functionality onto each of the three boards. This modular design allows for the ability to change the instrument from one of four types of instruments: pH/ORP/pION, four-electrode conductivity, two-electrode conductivity, and toroidal conductivity. In addition, analyzer repairs can be quickly accomplished by simply replacing the non-functioning board with one that is operational.

---

### **TEMPERATURE COMPENSATION**

The process temperature can be monitored using one of three types of RTD inputs: 3 kohm Balco, Pt100, and Pt1000. The secondary display area can also be set to display the temperature in degrees Celsius or Fahrenheit when the TB84TE Series analyzer is in the Measure mode of operation.

Since temperature affects the activity and disassociation of ions and hence the conductivity of the solution, several temperature compensation functions are available to correct for these effects. Temperature compensation options for conductivity and concentration include Manual (0.1N KCl based) and six types of Automatic Compensation routines. See Section 1, Introduction, for compensation types.

---

## ANALOG OUTPUTS

The TB84TE Series analyzer has two analog outputs. These outputs can be either direct or reverse acting and can be software-configured for a range of zero to 20 milliamps or four to 20 milliamps. Both outputs are separately scalable, isolated from the input, and isolated from one another.

The analog outputs provide process information to recorders, data loggers, and control systems. The information transmitted can represent (i.e., be sourced to) the conductivity, concentration, or temperature of the solution and be ranged across any portion of the particular measurement range. See Table 1-3, Specification, for minimum and maximum range values.

---

## RELAY OUTPUTS

The TB84TE Series analyzer has three Form C, SPDT relay outputs. The relays can be independently programmed to perform various functions as required by the application.

These functions include:

- Process control (Setpoint or Cycle Timer).
- Diagnostic condition notification.
- Cleaner control.

---

## High or Low Set Point

High or low set point relays are configurable for any value within the measurement range. Each set point relay output allows for separate programmability of relay function (high or low), set point value, deadband value, and delay.

The example shown in Figure 2-1 illustrates a high set point relay output of 10.00 mS/cm with a deadband of 0.10 mS/cm. The relay activates at 10.00 mS/cm and deactivates when the process drops below 9.90 mS/cm. The second half of the figure shows the same situation with a 1.0 minute delay before the high set point relay activates. Set point

functions are programmable as high or low acting. Setpoint, deadband, and delay value are all tunable parameters available in the Setpoint/Tune Mode of Operation.

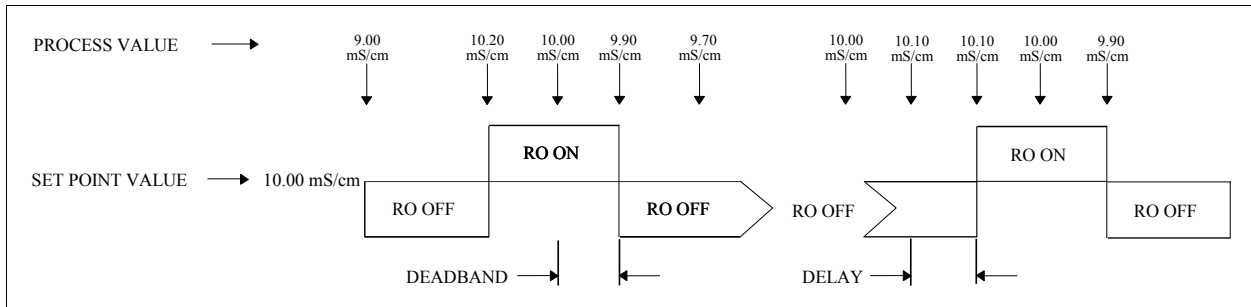

Figure 2-1. High Set Point and Time Delay Example.

### High or Low Cycle Timer

High or low cycle timer relays are configurable for any value within the measurement range. A cycle timer relay output allows for separate programmability of relay function (high or low), set point value, cycle time, and on time.

The example shown in Figure 2-2 illustrates a cycle timer that will be active when the process variable exceeds the high set point value of 10.00 mS/cm. Once active, the relay output energizes for the configured on time. As long as the process continues to exceed the set point value, the timer will reset itself at the end of the duty cycle (i.e., cycle time). The set point, cycle time, and on time are all tunable parameters available in the Setpoint/Tune Mode of Operation.

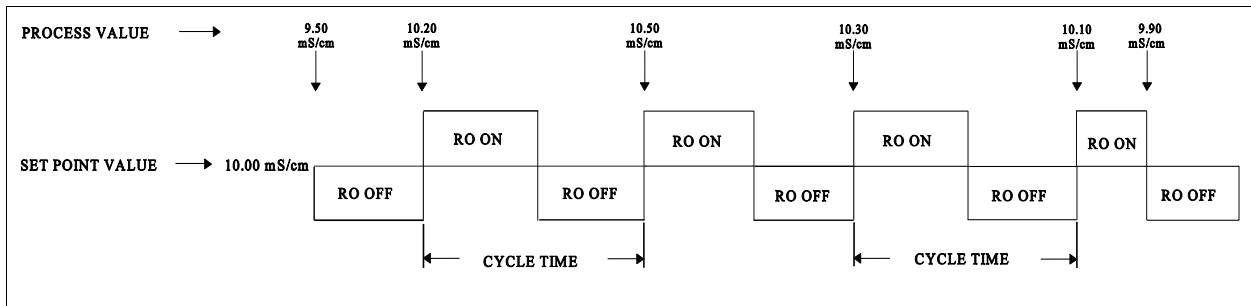

FIGURE 2.2. Cycle Timer High Set Point Example.

---

## Cleaner

Automatic sensor cleaning can be accomplished using one of the three relay outputs. At a prescribed time interval (i.e., cycle time), a cleaner relay output will energize and thus enable a cleaning device. The cleaner relay will remain energized for a configured cleaning period (i.e., on time). Since many cleaning devices use cleaning solutions that can affect the process measurement, the analog and non-cleaner relay outputs can be held during the cleaning period. If needed, non-cleaner relay outputs can be completely disabled (i.e., de-energized) instead of held. Thus, an operator does not need to be concerned with the possibility of a non-cleaner relay being held in an incorrect state during a cleaning cycle.

In addition to a cleaning period, a recovery period can be programmed to extend any configured hold and/or disabling condition beyond the clean period. This feature allows cleaning fluids to dissipate or sensor conditions to stabilize before returning to the normal mode of operation.

The set point, cycle time, and on time are all tunable parameters available in the Setpoint/Tune Mode of Operation.

---

## DAMPING

Damping can be adjusted from 0 to 99.9 seconds. This feature is useful in noisy process environments to help stabilize the displayed process variable and output current from excess bounce. Damping can be applied to the displayed and/or analog output values.

Damping simulates a capacitive type lag where reaction to any signal change is slowed according to an entered time constant. For example, a step change will reach approximately 63 percent of its final value in five seconds for five seconds of damping.

---

## DIAGNOSTICS

---

Diagnostics are provided for both the analyzer and sensor. Diagnostic detection of a serious condition that prevents the instrument from properly functioning enables preset Safe Mode states. These Safe Mode states are configured by the user and forces the outputs either high and/or low.

For problems that occur that do not render the instrument in a non-functioning state, the user has the option of linking these conditions to a Diagnostic Spike that is superimposed onto Analog Output One and/or to one or more relay outputs.

If the Diagnostic Spike is enabled, Analog Output One will modulate for one out of every six seconds. The magnitude of the modulation can be set from 0 to 100% of the analyzer's maximum output (i.e., 0 to 16 or 20 mA).

Diagnostic conditions cause the FAULT and FAULT INFO icons to be energized. Interrogation of each fault condition is available with a single keystroke.

---

### Analyzer

Four critical errors in operation are monitored and linked to the Safe Mode feature. These conditions include inoperable or incorrect input circuit, bad RAM (Random Access Memory), and damaged EE (Electrically Erasable) memory.

---

### Sensor

The analyzer continually performs diagnostic checks on sensor integrity. Inconsistencies in sensor performance are notified by the FAULT and FAULT INFO icons as well as the Spike Output and/or Diagnostic Relay(s) if configured.

Sensor faults include polarization, shorted/open temperature sensor, high and low PV, high and low temperature, and many more. See Section 13, Diagnostics, for more details.

---

## **Spike Output**

Remote notification of a problem condition can be initiated by the TB84TE Series analyzer using the SPIKE State in the Configure Mode. The Spike Output option allows users to program a 0 to 100% (i.e., 0 to 16 mA for 4 to 20 mA configurations or 0 to 20 mA for 0 to 20 mA configurations) pulse that will be impressed on Analog Output One for one second out of a six second repeating cycle should a problem condition be detected. Should the actual output of the analyzer be below mid-scale, the pulse will add current; if above mid-scale, it will subtract current.



---

## SECTION 3 - INSTALLATION

---

### INTRODUCTION

This section of the manual will aid the user in all levels of the installation process. The intention is to provide simple procedures for placing the TB84TE Series analyzer into service.

---

### SPECIAL HANDLING

Besides the normal precautions for storage and handling of electronic equipment, the analyzer has special static sensitive device (SSD) handling requirements. This equipment contains semiconductors subject to damage by discharge of static electricity; therefore, avoid direct contact with terminal block conductors and electronic components on the circuit board.

To minimize the chances of damage by static electricity, follow these techniques during wiring, service, troubleshooting, and repair.

1. Remove assemblies containing semiconductors from their protective containers only:
  - a. When at a designated static-free work station.
  - b. After firm contact with an antistatic mat and/or gripped by a grounded individual.
2. Personnel handling assemblies with semiconductors must be neutralized to a static-free work station by a grounding wrist strap connected to the station or to a good ground point at the field site.
3. Do not allow clothing to make contact with semiconductors. Most clothing generates static electricity.
4. Do not touch connectors, circuit traces, and components.

---

5. Avoid partial connection of semiconductors. Semiconductors can be damaged by floating leads. Always install electronic assemblies with power removed. Do not cut leads or lift circuit paths when troubleshooting.

6. Ground all test equipment.

7. Avoid static charges during maintenance. Make sure the circuit board is thoroughly clean around its leads but do not rub or clean with an insulating cloth.

**NOTE:** An antistatic field service kit, part number 1948385\_1, is available for personnel working on devices containing static sensitive components. The kit contains a static dissipative work surface (mat), a ground cord assembly, wrist bands, and alligator clip.

---

## UNPACKING AND INSPECTION

Examine the equipment upon receipt for possible damage in transit. File a damage claim with the responsible transportation company, if necessary. Notify the nearest ABB sales office.

Carefully inspect the packing material before discarding it to make certain that all mounting equipment and any special instructions or paperwork have been removed. Careful handling and installation will ensure satisfactory performance of the unit.

Use the original packing material and container for storage. Select a storage environment free of corrosive vapors and extreme temperature and humidity. Storage temperatures must not exceed -40 degrees to +70 degrees Celsius (-40 degrees to +158 degrees Fahrenheit).

Remove the protective film from the analyzer lens after the analyzer has been placed in its final installed location.

---

## LOCATION CONSIDERATIONS

When mounting the unit, leave ample clearance for removal of the front bezel and rear cover. Signal wiring should not run in conduit or open trays where power wiring or heavy electrical equipment could contact or interfere with the signal wiring. Twisted, shielded pairs should be used for the best results.

The mounting location should provide easy access for maintenance procedures and not be in a corrosive environment. Excessive mechanical vibrations and shocks as well as relay and power switches should not be in the immediate area. Additionally, this location must conform to the temperature and humidity constraints listed in the Table 1-3, Specifications.

---

## HAZARDOUS LOCATIONS

<b>WARNING</b>	<b>Use this equipment only in those classes of hazardous locations listed on the nameplate. Installations in hazardous locations other than those listed on the nameplate can lead to unsafe conditions that can injure personnel and damage equipment.</b>
----------------	-------------------------------------------------------------------------------------------------------------------------------------------------------------------------------------------------------------------------------------------------------------

Refer to Table 1-3, Specifications, in Section 1 for a list of certifications and approvals applicable to the TB84TE Series analyzer.

---

## RADIO FREQUENCY INTERFERENCE

Most electronic equipment is affected to some extent by radio frequency interference (RFI). Caution should be exercised with regard to the use of portable communications equipment in areas where this electronic equipment is being used. Post appropriate cautions in the plant as required.

---

## MOUNTING

The TB84TE Series analyzer can be pipe, hinge, wall, or panel mounted. Figure 3-1 shows the overall dimensions of the TB84TE without mounting hardware. Mounting hardware attaches to the four sets of threaded holes located on the corners of the main housing.

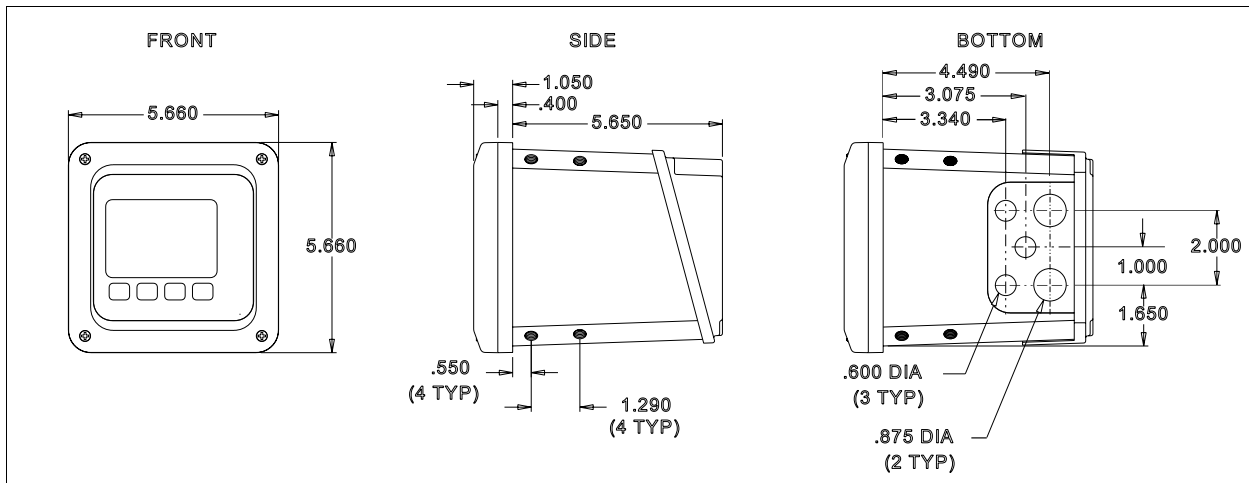

Figure 3-1. Overall Dimensions

---

### Pipe Mounting

The TB84TE Pipe Mount Kit (p/n 4TB9515-0124) contains a pipe and instrument mounting bracket with associated hardware. The pipe mounting bracket can be fitted to pipe sizes as large as two-inches.

Using Figure 3-2 as a reference, mount the TB84TE analyzer as follows:

- 1) Select the desired orientation of the analyzer.
- 2) Attach the instrument mounting bracket to the pipe mounting bracket using the supplied 3/8" x 3/4" bolts, 3/8" flat washers, 3/8" lock washers, and 3/8" nuts.
- 3) Attach the pipe mounting bracket to the pipe using the supplied 5/16" U-bolts, 5/16" flat washers, 5/16" lock washers, and 5/16" nuts.

4) Attach the instrument to the instrument mounting bracket using the supplied 3/8" x 5/8" bolts, 3/8" flat washers, and 3/8" lock washers.

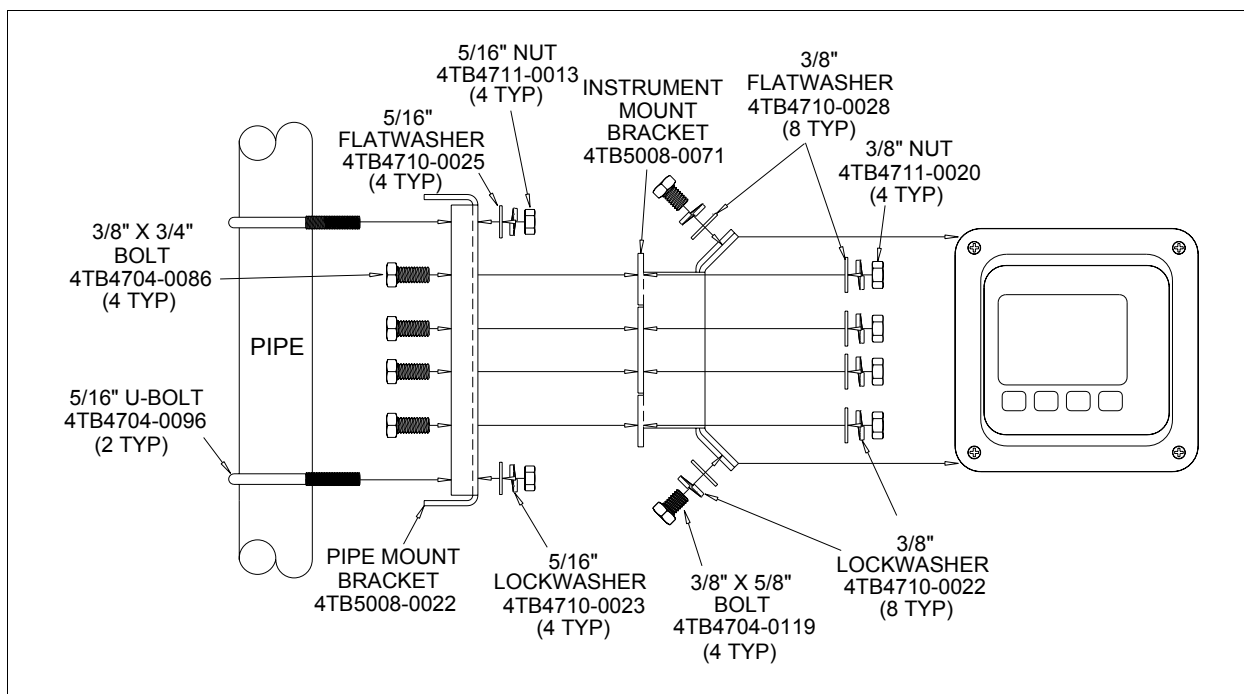

Figure 3-2. Pipe Mount Installation Diagram

### Hinge Mounting

The TB84TE Hinge Mount Kit (p/n 4TB9515-0125) contains L- and instrument mounting brackets, a stainless steel hinge, and associated hardware. The Hinge Mount Kit allows for a clear view of the display while maintaining easy access to the rear of the instrument.

Using Figure 3-3 as a reference, mount the TB84TE analyzer as follows:

- 1) Select the desired location and orientation of the analyzer.
- 2) Attach the L-bracket to the selected location using the appropriate type of fastener based on the mounting surface material.

3) Attach the stainless steel hinge to the L-bracket using the supplied 3/8" x 3/4" bolts, 3/8" flat washers, 3/8" lock washers, and 3/8" nuts.

4) Attach the instrument mounting bracket to the stainless steel hinge using the supplied 3/8" x 3/4" bolts, 3/8" flat washers, 3/8" lock washers, and 3/8" nuts.

5) Attach the instrument to the instrument mounting bracket using the supplied 3/8" x 5/8" bolts, 3/8" flat washers, and 3/8" lock washers.

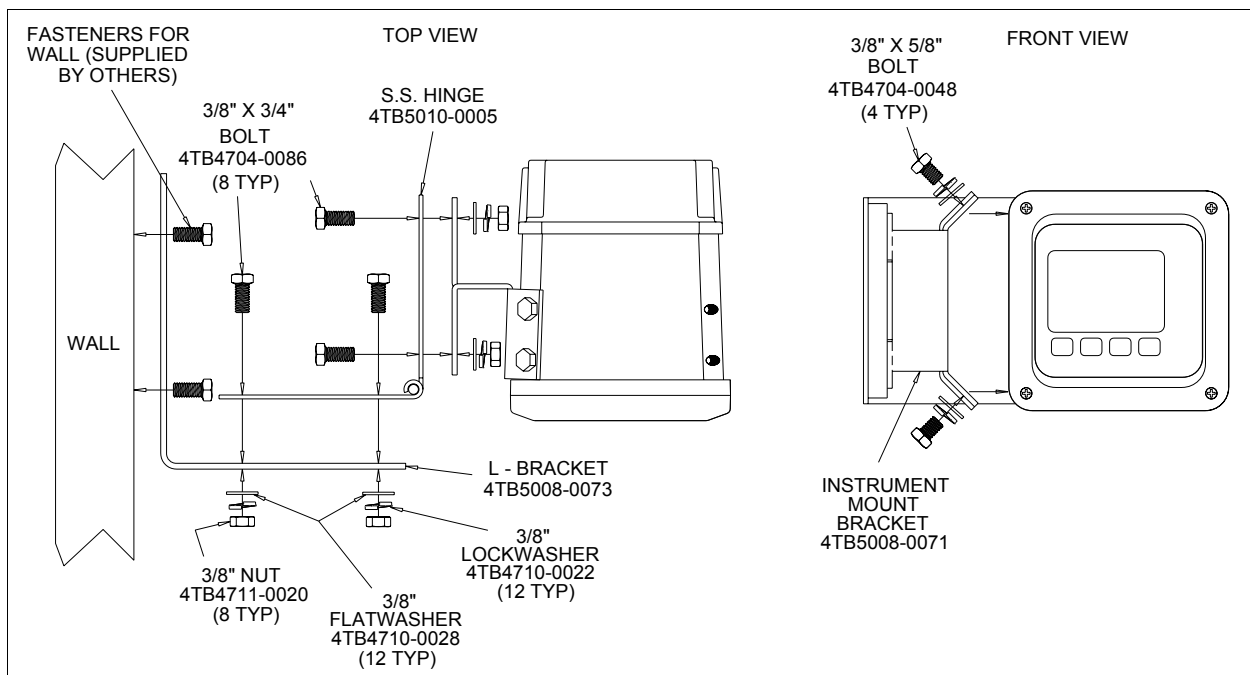

Figure 3-3. Hinge Mount Installation Diagram

## Wall Mounting

The TB84TE Wall Mount Kit (p/n 4TB9515-0156) contains an instrument mounting bracket with associated hardware. Wall mounting accommodates installations where the analyzer can be positioned for a clear line of sight and free access to the rear terminations. These types of installation include supporting beams, flange brackets, and wall ends.

Using Figure 3-4 as a reference, mount the TB84TE analyzer as follows:

- 1) Select the desired location and orientation of the analyzer.
- 2) Attach the instrument mount bracket to the selected location using the appropriate type of fastener based on the mounting surface material.
- 3) Attach the instrument to the instrument mounting bracket using the supplied 3/8" x 5/8" bolts, 3/8" flat washers, and 3/8" lock washers.

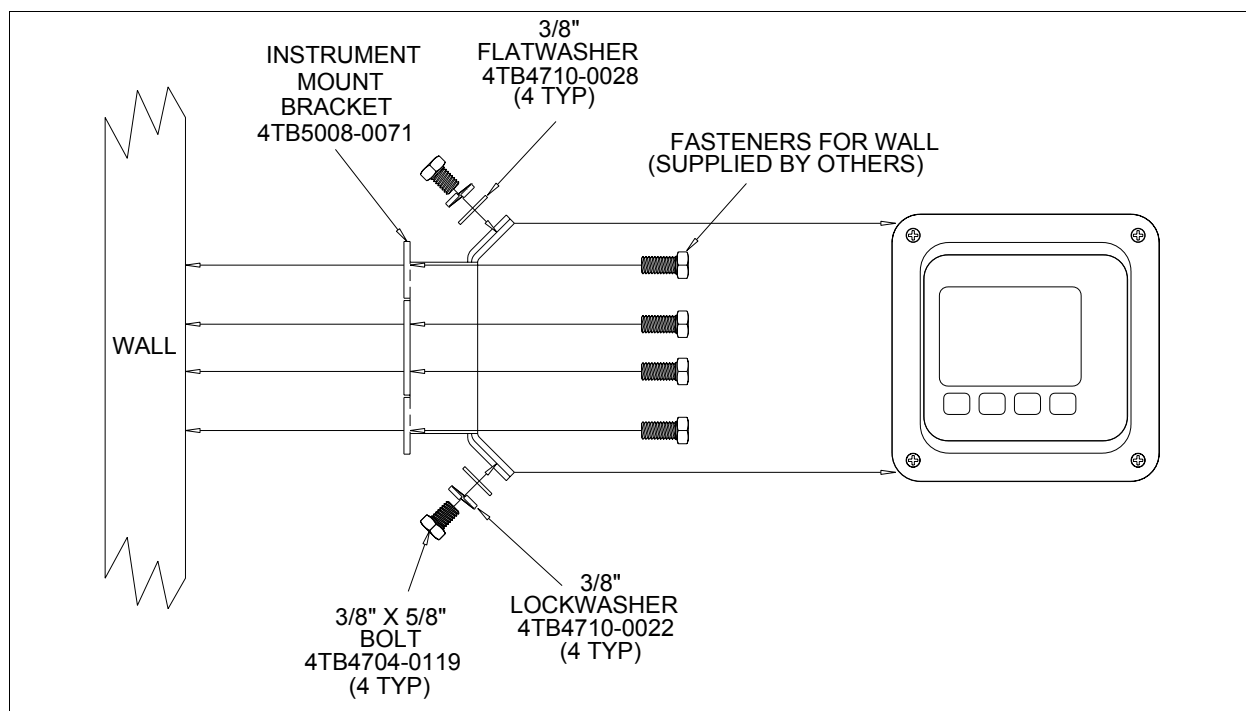

Figure 3-4. Wall Mount Installation Diagram

### Panel Mounting

The TB84TE Panel Mount Kit (p/n 4TB9515-0123) contains four panel bracket assemblies and a panel gasket. The TB84TE enclosure conforms with DIN sizing and requires a 135.4 mm x 135.4 mm cut-out for panel mounting. The panel brackets accommodate a maximum panel thickness of 3/8".

Using Figure 3-5 as a reference, mount the TB84TE analyzer as follows:

- 1) Select the desired location of the analyzer.
- 2) Cut a 135.4 mm x 135.4 mm hole with diagonal corners through the panel as shown in Figure 3-5.
- 3) Install the panel gasket onto the instrument.
- 4) Remove Rear Cover if necessary, and insert the instrument through the panel cut-out.
- 5) Attach the panel mounting bracket assemblies to the four corners of the analyzer.
- 6) Tighten the adjustment screws on the panel mounting brackets until the analyzer seats against the panel. Note, do not over-tighten the adjustment screws or damage to the brackets and panel may result.

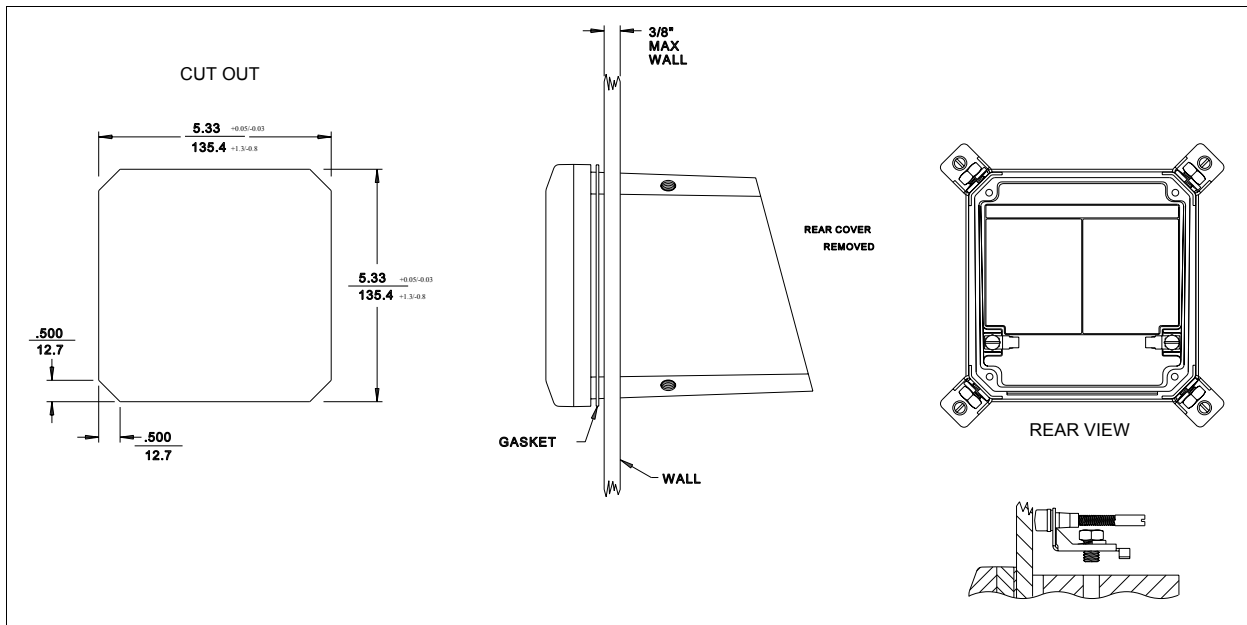

Figure 3-5. Panel Mount Installation Diagram

---

## WIRING CONNECTIONS AND CABLING

---

**CAUTION**

**To prevent possible signal degradation, separate metal conduit runs are recommended for the sensor, signal, and power wiring.**

Under ideal conditions, the use of conduit and shielded wire may not be required. However, to avoid noise problems, power, signal, and output wiring should be enclosed in separate conduit. Just prior to entering the housing, rigid conduit should be terminated and a short length of flexible conduit should be installed to reduce any stress to the housing.

Note: To maintain a NEMA 4X/IP65 rating, use approved conduit connections or cord grips that have the same type of ratings.

Power and signal wiring must bear a suitable voltage rating, have a maximum temperature rating of 75°C (167°F), and must be in accordance with all NEC requirements or equivalent for the installation site. Use either a standard three-prong grounded flexible CSA certified line cord or equivalent for power supply connections or hard wire directly to the AC supply. If hard wiring the AC power supply, use stranded, 14 AWG copper conductor wire.

Signal wiring should not be run in the same conduit or open trays where power wiring for high amperage electrical equipment exists. Ensure the final installation of signal and power wiring prevents physical damage and/or electrical interfere.

Note: Use weatherproof connections for all wiring ports. Heyco RLTF ½" and LTF 9 cable grips are available through ABB. See Section 17, Support Services.

The TB84TE Advantage Series analyzer accepts wire sizes 12 to 24 AWG. Signal wiring should always be twisted, shielded pairs to ensure the best performance. Pin-style terminals are recommended for all connections and available as kits from the factory. See section 17, Support Services, for more information.

---

## Power Wiring

---

**WARNING**

Disconnect the AC line cord or power lines from the operating branch circuit coming from the source before attempting electrical connections. Instruments powered by AC line voltage constitute a potential for personnel injury due to electric shock.

**WARNING**

Keep the enclosure and covers in place after completing the wiring procedures and during normal operation. Do not disconnect or connect wiring or remove or insert printed circuit boards unless power has been removed and the flammable atmosphere is known NOT to be present. These procedures are not considered normal operation. The enclosure prevents operator access to energized components and to those that can cause ignition capable arcs. Failure to follow this warning can lead to unsafe conditions that can injure personnel and damage equipment.

The TB84TE Series analyzer does not require any adjustments to accept different line-power voltages. Power connections are located in the back of the instrument housing. The terminal block label identifies all line power, output signal, and sensor connections.

Notes:

1. ABB recommends installing a power line switch for safety purposes and for providing power-up and power-down convenience when servicing the analyzer.
2. Do not power the system from a transformer that also powers large motor loads (over five horsepower) or any other type of equipment that generates line voltage surges, sags and excessive noise.

Using Figure 3-7 as a reference, make line power connections as follows:

- 1) Strip wire insulation back approximately 0.250" (seven millimeters) to ensure the bare wire will make good contact with the Insulated Pin Lug terminals and will not be exposed beyond the pin insulator.

---

2) Crimp Pin Lug terminals to wire using Panaduit CT 570 or equivalent.

3) Connect the specified line voltage to TB1-1 (Line - L1), the neutral to TB1-2 (Neutral - L2), and the ground to enclosure protective ground terminal located below TB1.

---

### **Analog Output Signal Wiring**

The terminal block label identifies the analog output connections. Terminal polarity is shown and must be observed to ensure proper operation. The maximum load resistance for the analog outputs is specified in Table 1-3, Specifications. The maximum load resistance must include all devices and wiring within the analog output current loop. See Figure 3-7 for additional wiring information.

Using Figure 3-7 as a reference, make analog output connections as follows:

1) Strip wire insulation back approximately 0.250" (seven millimeters) to ensure the bare wire will make good contact with the Insulated Pin Lug terminals and will not be exposed beyond the pin insulator.

2) Crimp Pin Lug terminals to the wire using Panaduit CT 570 or equivalent.

3) Connect the wiring to the appropriate analog output terminals.

---

### **Relay Output Signal Wiring**

The relay outputs are shipped from the factory in the default state of Normally Open. That is, the relay contacts will be open when the relay is not energized. To change the normal state of any of the three relay outputs, switches on the power supply PCB assembly must be moved to different positions.

Using Figure 3-6 as a reference, change the normal state of any relay output as follows:

- 1) Unscrew the four captive screws located at the four corners of the Front Bezel Assembly.
- 2) Lightly pull the Front Bezel Assembly from the Shell Assembly.
- 3) Identify the Power Supply PCB Assembly and relay state switches using Figure 3-6.
- 4) Move the switch position to the desired normal state (i.e., Normally Open or Normally Closed.)

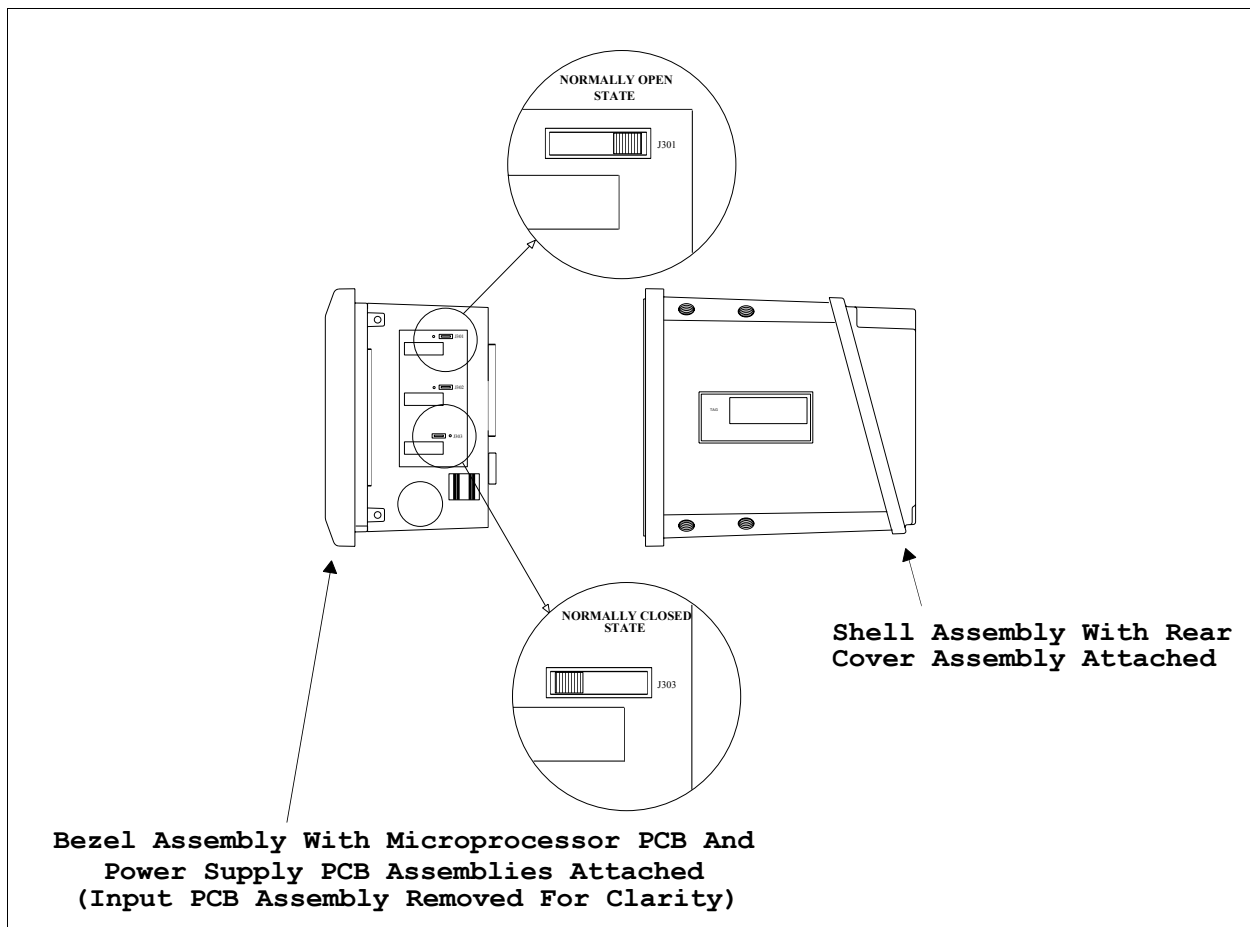

Figure 3-6. Normal State Relay Jumper Location.

---

Using Figure 3-7 as a reference, make relay output connections as follows:

- 1) Strip wire insulation back approximately 0.250" (seven millimeters) to ensure the bare wire will make good contact with the Insulated Pin Lug terminals and will not be exposed beyond the pin insulator.
- 2) Crimp Pin Lug terminals to the wire using Panaduit CT 570 or equivalent.
- 3) Connect the wiring to the appropriate relay output terminals.

---

### Two-Electrode Sensor Wiring

Instrument connections for the sensor wiring are located next to the signal connections. Sensor wiring should run in shielded conduit, or similar, to protect it from environmental influences. Do not allow the wires to become wet or to lay on the ground or over any other equipment. Ensure cables are not abraded, pinched, or bent during installation.

The sensor cable has five leads and must be connected to the terminal block in the rear cavity of the TB84TE analyzer. The five leads are color coded and have the following functions and connections:

Terminal Block Location	Sensor Color Code	Function
TB2-1	Green	Drive
TB2-2	Red	Not Used
TB2-3	White	Not Used
TB2-4	Black	Drive
TB2-5	Blue	RTD
TB2-6	Yellow	RTD
TB2-7	Hvy Grn	Shield
TB2-8	N/A	N/A

Use Figure 3-7 as a reference for making wiring terminations. Note, maximum wire gauge for the terminal connectors is 12 AWG; minimum is 24 AWG. Pin-style terminals are recommended for all connections.

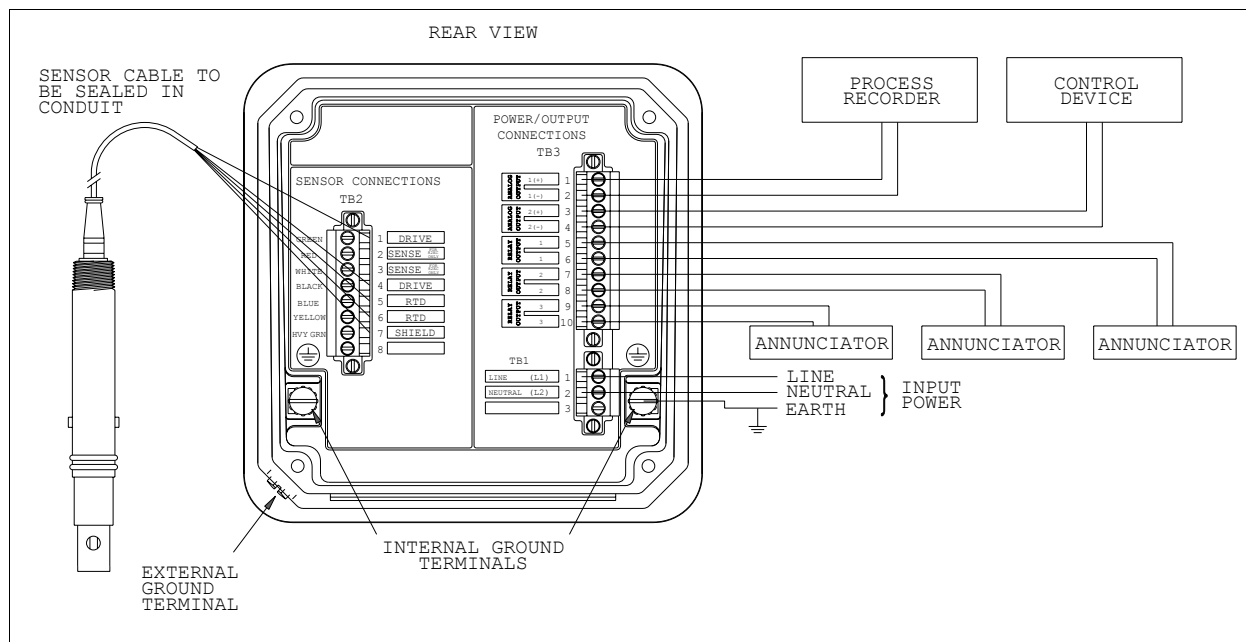

Figure 3-7. Instrument Wiring Diagram.

## GROUNDING

The customer and/or wiring contractor is responsible to ensure the analyzer, associated control or test equipment, and all exposed conductive materials are properly grounded. Grounding procedures should be in accordance with local regulations such as the National Electrical Code (NEC), Canadian Electrical Code (CEC), or equivalent. Equipment installations must not pose a hazard, including under fault conditions, to operation and service personnel.

Signal wiring should be grounded at any one point in the signal loop. The analyzer enclosure should be connected to earth ground using a large area conductor having less than 0.2 ohms or resistance. Internal and external earth ground terminals are provided for convenience and shown in Figure 3-7.

---

Notes:

1. Because of the prevailing differences in soil conditions and in acceptable grounding practices throughout the world, the scope of this product instruction is not intended to be used to describe grounding electrode systems. The customer is responsible to ensure a grounding electrode system is acceptable to the local building and wiring codes.
2. Using the structural metal frame of a building as the required equipment grounding conductor for the analyzer is not advised.

---

**OTHER EQUIPMENT INTERFACE**

The TB84TE Series analyzer provides two isolated current outputs that are proportional to the process variable(s). Since the analyzer output is isolated, each current loop may have a maximum of one non-isolated device within its circuit. The maximum load on the each current loop must not exceed the specification listed in Table 3-1, Specifications.

---

**INSTRUMENT ROTATION**

The TB84TE Series analyzer has four pairs of threaded mounting holes. Since these holes are located at the corners of the instrument, the TB84TE Series analyzer can be positioned in any of the four positions as demonstrated in Figure 3-8.

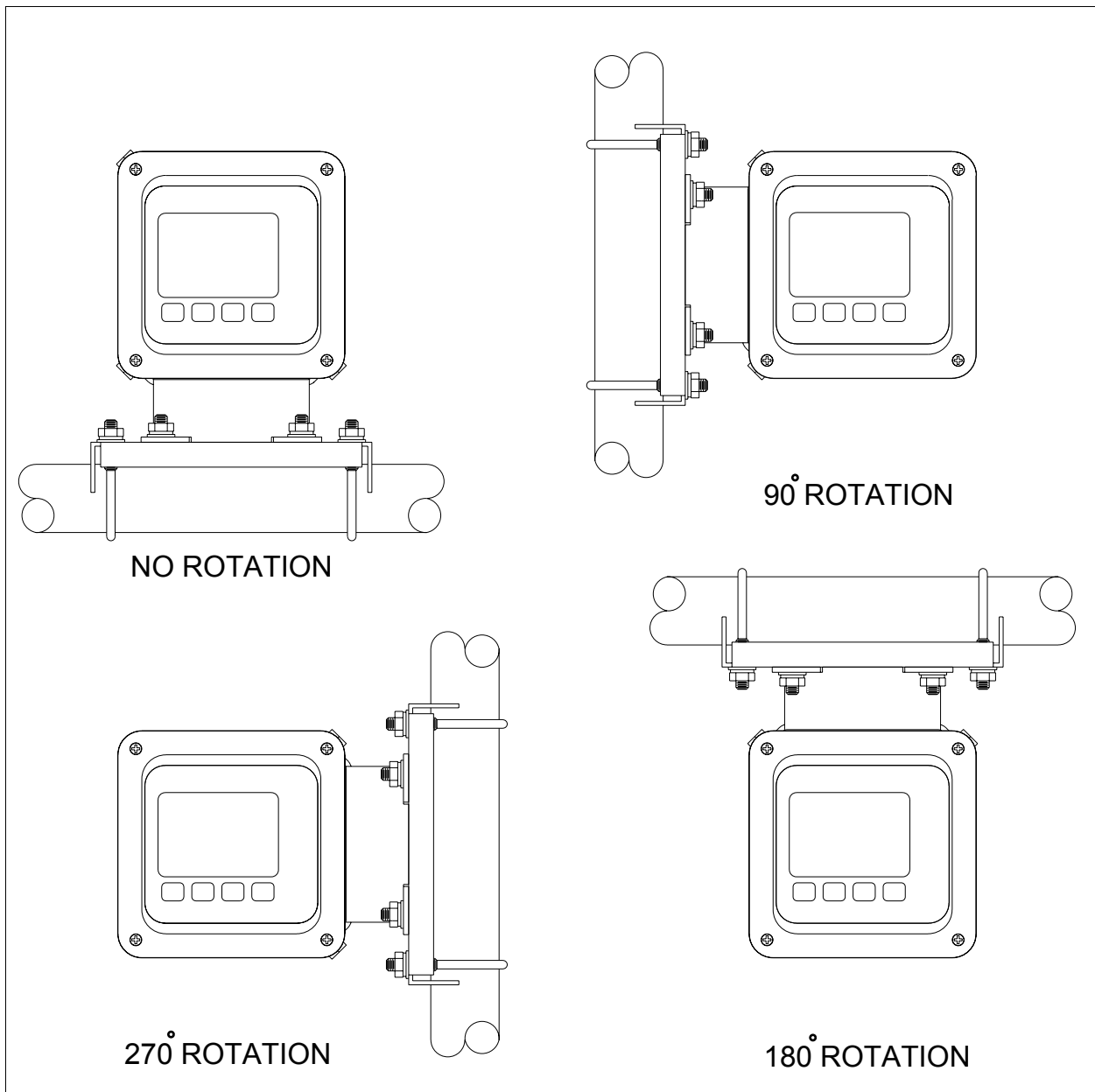

Figure 3-8. Mounting Rotation (Pipe Mount Shown)

---

## SECTION 4 - OPERATING PROCEDURES

---

### INTRODUCTION

The TB84TE Series analyzer has seven main operating modes: Measure, Calibrate, Output/Hold, Configure, Security, secondary Display, and Setpoint/Tune. Within each mode, several programming states containing functions specific to the related mode are available.

The TB84TE Series analyzer is equipped with a built-in user interface through which all analyzer functions are programmed or monitored. Two display regions in the custom LCD handle the majority of instrument functions. These regions include a primary display area for the process variable (e.g., Conductivity) and a secondary display area for programming text prompts or auxiliary information.

In addition to the user-friendly interface, the TB84TE Series analyzer is equipped with a group of icons that alerts the user to an existing FAULT condition, diagnostic SPIKE output, output HOLD condition, or activated RELAY. These icons are located at the top of the LCD and are only energized when the specified condition is detected. FAULT conditions are shown in the secondary display when the instrument is in the Measure Mode of Operation and the FAULT INFO key has been pressed.

---

### OPERATOR INTERFACE CONTROLS REVIEW

---

#### Liquid Crystal Display (LCD)

The LCD contains nine regions that provide the user with information on the process variable, engineering unit, mode of operation, output hold condition, fault, relay activation, secondary variable, and key function assignments. Figure 4-1 shows a fully energized LCD, Smart Keys, and mode text.

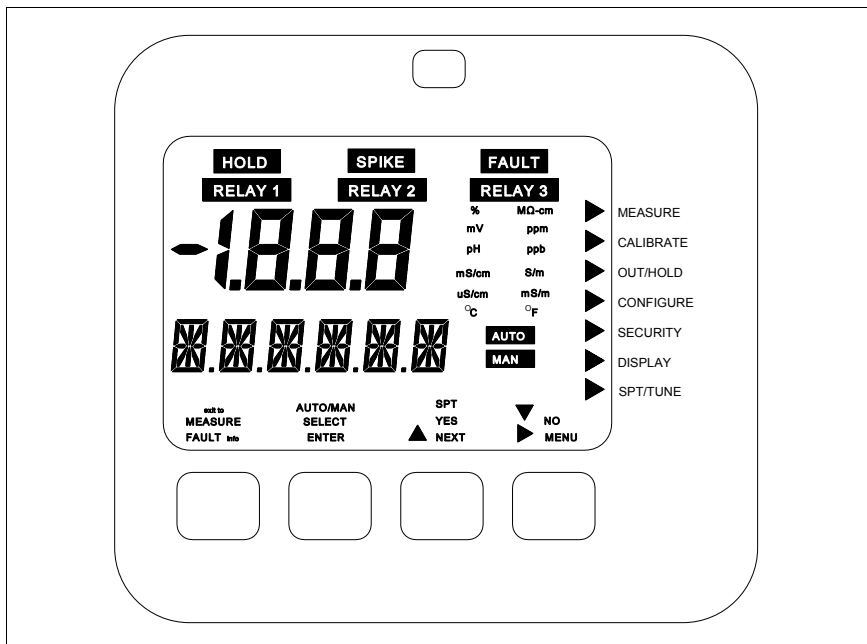

Figure 4-1. Fully Energized Display And Supporting Information.

The top set of icons informs the user of abnormal operating conditions such as an output HOLD, FAULT, diagnostic SPIKE output, or RELAY activation. These icons are only energized when such a condition is detected and are active in all modes of operation.

For the mode of operation indicators (i.e., right arrows positioned next to the mode text), only one indicator will be lit and will indicate the current mode of operation of the analyzer. As a user moves from one mode to the next, the appropriate indicator will energize. The mode of operation indicators are active in all modes of operation.

The process variable is displayed in the three and one-half digit, seven segment region. This display region is supported by the engineering unit region. These regions are active in all modes of operation; however, in some programming states, the process variable region will be used for data entry and the engineering unit region will reflect the data unit.

---

The secondary variable is displayed in the six-character, fourteen segment region. This display region is used for displaying secondary information and fault information in the Measure Mode of Operation and programming prompt in all other modes of operation. Due to the limited number of characters for this display region, much of the prompting takes the form of text abbreviations (see Appendix B for a list of abbreviations.) This region is active in all modes of operation.

The Smart Key assignments are grouped into four sets of icons, each group directly positioned above one of the four keys. These icons are textual representations of the function for the associated key. Only one icon will be energized per Smart Key at any given time.

---

### **Multi-Function Smart Keys**

A five-button, tactile keypad is located on the front panel of the analyzer. Four of the buttons are embossed to easily show their location. A fifth, hidden button located top, center of the keypad has been included to provide access to functions that are infrequently used.

The four embossed keys are called Smart Keys since their functions are dependent on the mode and/or state of the instrument. Since these four keys do not have a preassigned function, multiple functions can be assigned to a single key at different times by energizing the appropriate icon. Using this Smart Key method, a smaller number of keys can be used without complicating or reducing analyzer functionality. If a Smart Key does not have an icon energized above its location, this Smart Key does not have a function and will not initiate an action when pressed.

**Table 4-1. Smart Key Definition of Operation**

<b>Icon</b>	<b>Smart Key Function</b>
exit to MEASURE	Escapes back to the Measure Mode from all other modes or programming states of operation. This function is not available in the Measure Mode.
FAULT info	Accesses information on diagnostic Problem or Error Conditions. Displays this information as a short text string and code. This function is only available in the Measure Mode.
AUTO/MAN	Not used at this time.
SELECT	Selects the mode or programming state of operation shown in the secondary display region.
ENTER	Stores configured items and data into permanent memory.
SPT	A shortcut key to the Setpoint/Tune Mode of Operation. This function is only active in the Measure Mode.
YES	Affirms the action that is about to take place.
	Increments numeric values or moves through a series of parameters.
NEXT	Increments through a series of programming states.
	Decrements numeric values or moves through a series of parameters.
NO	Denies the action that is about to take place.
	Moves the flashing data entry value one space to the right.
MENU	Increments through the modes of operation.

---

For each operating mode and/or state, pressing the Smart Key initiates the displayed function of that Smart Key. For example, the function NEXT allows a user to cycle through a series of programming states for a given mode of operation. The function SELECT enables the user to enter into the displayed mode or state of operation. Using this method, the TB84TE Series analyzer guides the user through the necessary steps used to program or monitor any given function. A general description of each Smart Key function is given in Table 4-1.

---

**MODES OF OPERATION**

The Measure Mode is the normal operating mode of the TB84TE Series analyzer and is the default mode upon power-up. The Measure Mode is the starting point for entry into other modes of operation. Each mode contains a unique set of analyzer functions or states. These modes and their related functions are listed in Table 4-2.

**Table 4-2. Mode of Operation Definitions**

MODE	FUNCTION
Measure	Used to display the process and secondary variables - the normal operating mode for the analyzer.
Calibrate	Used to calibrate input and analog output functions.
Out/Hold	Used for on-line tuning of analog output parameters or to manually set the analyzer outputs, for example, during maintenance.
Configure	Used to configure analyzer functions such as the type of analyzer, temperature sensor, temperature compensation, output range, and diagnostic parameters.

---

MODE	FUNCTION
Security	Used to enter password protection for the Calibrate, Output/Hold, Configure, and Setpoint/Tune Modes of Operation.
Display	Used to select the variable that will be shown in the secondary display region when the analyzer is in the Measure Mode of Operation.
SPT/Tune	Used for on-line tuning of relay output parameters.

---

#### **HOLD ICON**

The Hold icon energizes when a hold condition is active. Outputs can be either manually or automatically held.

Manual activation is accessible in the Output/Hold Mode of Operation. In this mode, the Hold State permits the output to be held at the current level and/or state or at a level and/or state manually set by the user.

When a relay output is configured as a Cleaner, an option to enable an automatic hold condition using the levels and states capture directly before initiating the cleaning operation can be selected. The hold condition only occurs during the cleaning relay on and recovery times and can be separately set for the analog and relay outputs. If desired, the relay outputs can be disabled instead of held during a cleaning cycle.

---

#### **FAULT ICON**

The Fault icon energizes when a fault condition has been detected by the TB84TE Series analyzer. Fault conditions include all problem and error detection as outlined in Section 13, Diagnostics.

---

## **SPIKE ICON**

The Spike Output function modulates Analog Output One from the normal level representative of the process variable to a value configured as a set percentage of output current. When the TB84TE Series analyzer has detected a fault condition and the Spike Output function has been enabled, Analog Output One will begin to modulate and the Spike icon will energize. For more information on Spike Output and Fault conditions, see Section 13, Diagnostics.

---

## **RELAY ICONS**

The Relay icons are composed of three individual icons. Each icon represents one of the three integral relay (i.e., Relay One, Relay Two, and Relay Three.) When a relay changes from its normal state to an energize state, the corresponding Relay icon also energizes. Since the normal state of each relay can be set by a switch, the relay icon will only inform the user of a state change and not whether the relay has closed or opened.



---

## SECTION 5 - MEASURE MODE

---

### INTRODUCTION

The Measure Mode is the normal operating mode of the analyzer and is the active mode upon analyzer power-up. In this mode, the process variable, output hold state, fault condition state, spike output state, relay output states, and secondary display information are displayed. From the Measure Mode, other modes of operation and fault information can be accessed.

---

### BOREDOM SWITCH

When entering an operating mode or state and not returning to the Measure Mode as the final step, the TB84TE Series analyzer automatically returns to the Measure Mode of Operation after 20 minutes of unattended use. This feature ensures the analyzer will always be returned to its normal mode of operation.

---

### PRIMARY DISPLAY

The primary display shows the process variable. The value of this variable is dependent on the configured analyzer, type of temperature compensation, temperature value, solution conductivity, and damping value. The engineering units for the process variable are dependent only on the configured analyzer. Table 5-1 lists the analyzer types and corresponding engineering units.

Table 5-1. Engineering Unit And Analyzer Relationship

<b>ANALYZER TYPE</b>	<b>ENGINEERING UNIT</b>
Conductivity	mS/cm μS/cm
Concentration	ppm (parts per million) ppb (parts per billion) % (percent) User Defined

---

## **SECONDARY DISPLAY**

The secondary display has the ability to show a large variety of information. Since the display area only has six characters, only one item can be shown at any given time. Typically, this region will be used for displaying the process temperature in degrees Celsius; however, it can be changed to display the process temperature in degrees Fahrenheit, output current in milliamperes (i.e., mA) for each analog output (shown separately), sensor group, sensor type, conductivity value and solute name for a concentration analyzer, and firmware revision. See Section 10, Secondary Display, for more information.

---

## **FAULT INFORMATION Smart Key**

Fault information can only be accessed from the Measure Mode of Operation and is interrogated using the FAULT Info Smart Key. A fault condition causes the FAULT icon to blink and the FAULT Info Smart Key to appear. These indicators will be energized as long as the fault condition is present.

When pressing the FAULT Info Smart Key, the first fault condition will be shown in the secondary display. A short text string followed by the fault code will be sequentially shown. Depressing the FAULT Info Smart Key progressively moves from one fault to the next until all faults have been shown. Once all faults have been interrogated, the FAULT icon will no longer blink and remains energized until all fault conditions have been removed. If a new fault condition is detected, the FAULT icon will begin to blink to inform the user of the newly detected condition. For more information on fault conditions and codes, see Section 13, Diagnostics.

---

## **SPT Smart Key**

The SPT or Setpoint Smart Key provides a short-cut directly to the SPT/TUNE Mode of Operation. This short-cut provides quick access to tunable relay parameters.

---

## MENU Smart Key

The MENU Smart Key provides access to all other modes of operation. By pressing the MENU Smart Key, the analyzer moves from one mode of operation to the next. Visual feedback is provided in two manners: the mode indication arrow moves to the next mode of operation (e.g., Calibrate) and the secondary display shows the text string representative of that mode (e.g., CALIBR). Access into the displayed mode of operation is allowed using the SELECT Smart Key. An escape function to the Measure Mode of Operation is provided using the Exit to MEASURE Smart Key.

As seen by the detailed screen flow diagram shown in Figure 5-1, pressing the MENU Smart Key when in the Measure Mode moves the user to the Calibrate Mode. Once in the Calibrate Mode, pressing the Exit to MEASURE Smart Key returns the analyzer back to the Measure Mode, pressing the SELECT Smart Key moves the analyzer into the Calibrate States of Operation, and pressing the MENU Smart Key moves the analyzer to the Output/Hold Mode of Operation. Use Figure 5-1 to identify the Smart Key assignments and the resulting action.

Each mode of operation contains many states used to set or tune the TB84TE Series analyzer functions. In the following sections of this product instruction manual, all modes of operation will be discussed. Screen flow diagrams showing the programming text prompts, Smart Key assignments, and the resulting action for each Smart Key are also included. Refer to Appendix B for programming text string definitions and a programming function tree showing the relationship of all modes and states of operation.

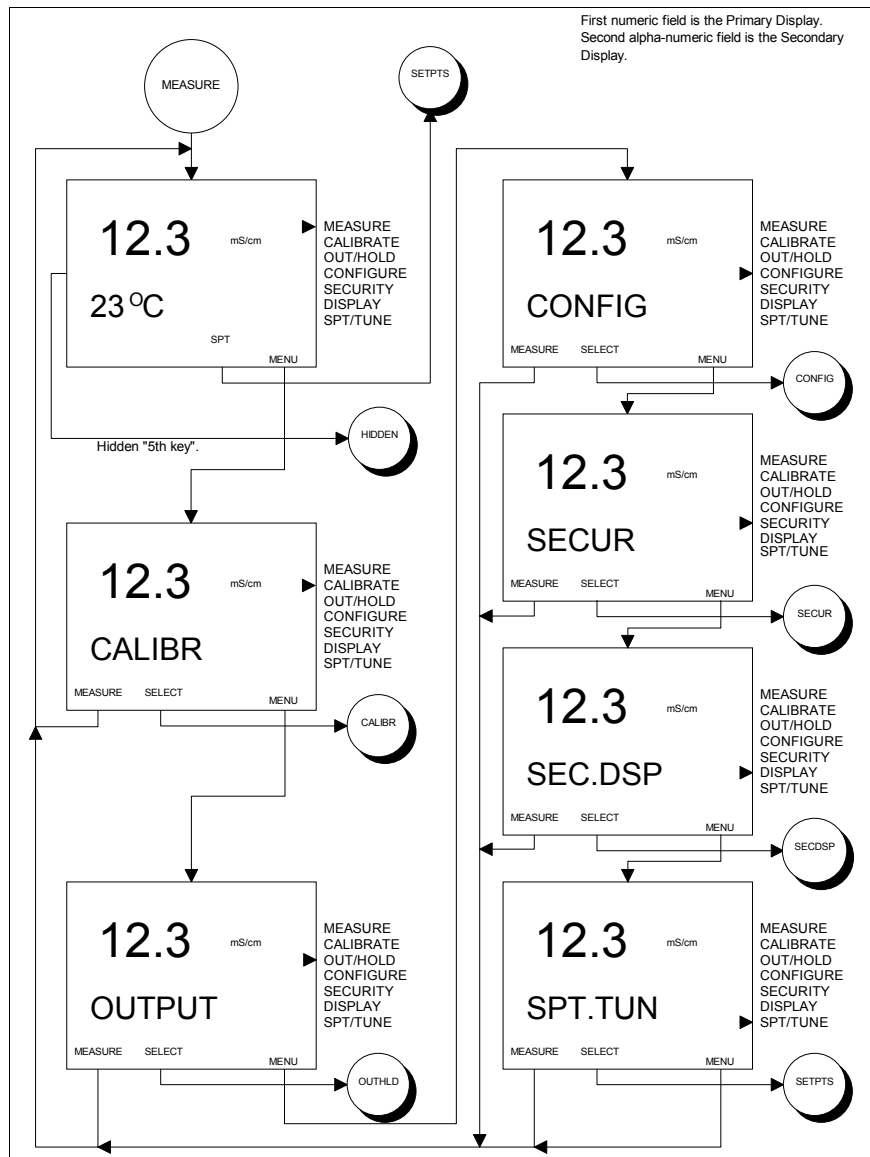

Figure 5-1. Screen Flow Diagram For Measure Mode of Operation.

---

## SECTION 6 - CALIBRATE MODE

---

### INTRODUCTION

The Calibrate Mode of Operation provides the ability to calibrate the sensor input, temperature input, and analyzer outputs. These functions (i.e., Calibrate States of Operation) include process variable, temperature, edit, reset, and output calibration.

---

### CALIBRATE STATES OF OPERATION

The Calibrate Mode consists of six states of operation. Table 6-1 describes the function of each state of operation.

**Table 6-1. Calibrate States**

State	Function
CON.CAL	Used to calibrate the input from the process sensor using a one-point smart calibration that adjusts the offset, slope, or both based on the sensor calibration history.
TMP.CAL	Used to calibrate the input from the temperature sensor using a one-point smart calibration that adjusts the offset, slope, or both based on sensor calibration history.
EDT.CAL	Used to manually adjust the process and temperature offset and slope values.
RST.CAL	Used to restore calibration values for the process variable and temperature to factory settings.
A01.CAL	Used to calibrate Analog Output One. Requires an external validation device.
A02.CAL	Used to calibrate Analog Output Two. Requires an external validation device.

When in the Calibrate Mode, the NEXT Smart Key provides access to all Calibrate States. Pressing the NEXT Smart Key sequentially moves the user through each Calibrate State. This cycle repeats until a Calibrate State is selected using the SELECT Smart Key, or the escape function is chosen using the Exit To MEASURE Smart Key. Use Figure 6-1 to identify the Smart Key assignments and the resulting action.

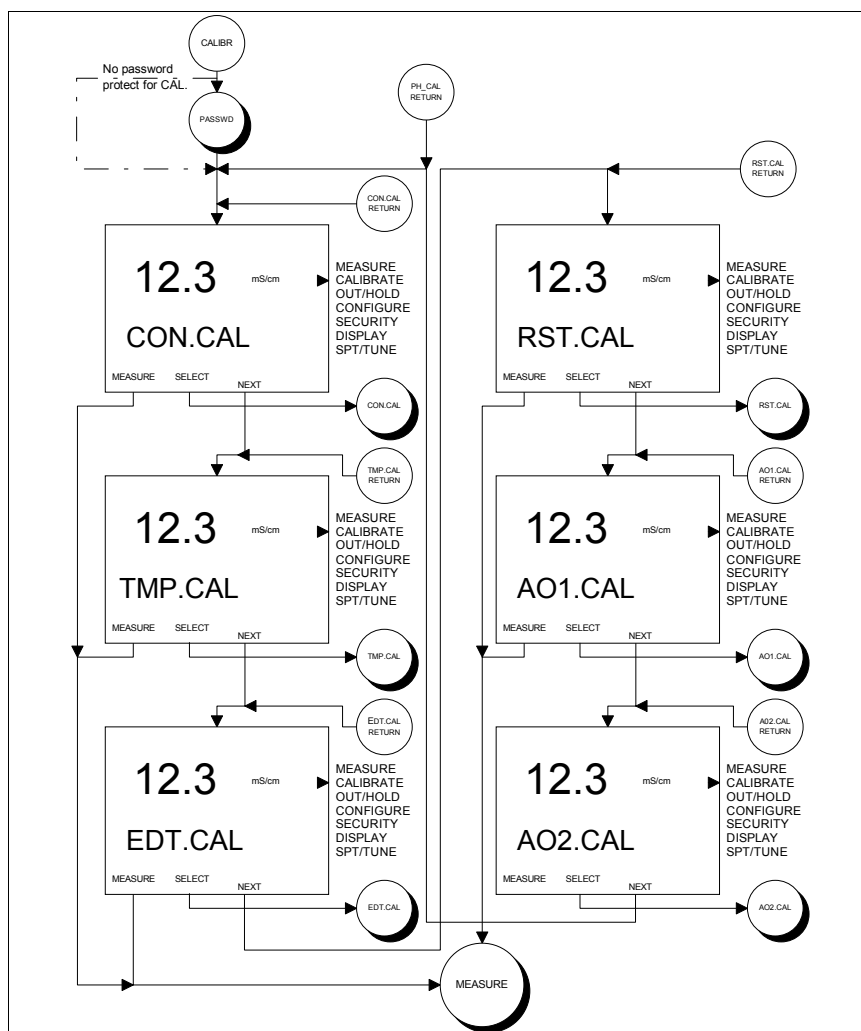

Figure 6-1. Screen Flow Diagram For Calibrate States of Operation.

The following subsections contain detailed descriptions of each Calibrate State of Operation.

---

## Conductivity/Concentration Calibrate State

The Conductivity/Concentration Calibrate State is a smart one-point calibration routine that allows for single- or dual-point calibrations. By initiating calibrations at two different conductivity values having ample separation, the TB84TE Series analyzer automatically adjusts the offset, slope, or both in order to obtain the best sensor performance. Since this routine only uses the most recent calibration data, calibration can be conducted throughout the sensor's life thus ensuring consistent sensor performance. If an incorrect calibration has been entered, the Reset Calibrate State provides the ability to return analyzer calibration values to factory settings. See Reset Calibrate State in this section.

Note: The Reset Calibration State will reset all calibration values including the process variable and temperature; therefore, process variable and temperature calibrations are required after performing the Reset Calibration procedure.

Since the TB84TE Series analyzer can be configured as a Conductivity or Concentration analyzer, the smart one-point calibration routine automatically uses the same units as the measured process variable. Thus, a Conductivity Analyzer uses conductivity units and a Concentration Analyzer uses the user-defined units set in the Configure Mode of Operation.

Conduct a Conductivity or Concentration Calibration using the following procedure:

- 1) Once the sensor has been installed and has reached the temperature of the process solution, verify the process variable value using a grab sample and an external validation device having the same type of temperature compensation.
- 2) Select CON.CAL (i.e., Conductivity/Concentration Calibrate State) in the Calibrate Mode of Operation using the SELECT Key.

- 
- 3) Confirm the displayed reading is STABL? (i.e., stable) using either the YES or NO Key. If the NO Key is pressed, the TB84TE Series analyzer will return to the Conductivity/Concentration Calibrate State (i.e., CON.CAL). For an unstable condition, conduct one or more of the following steps:
    - a) Wait until the process liquid composition stabilizes,
    - b) Check to see if the TB84TE Series analyzer has detected a Fault condition by looking for the Fault icon on the LCD. Interrogate the fault by escaping to the Measure Mode using the Exit to MEASURE Key and the FAULT Info Key in that order.
    - c) See Section 14, Troubleshooting.
  
  - 4) If the YES Key is pressed, enter the NEW VAL (i.e., new process variable) that reflects the difference between the grab sample value and the indicated value when the grab sample was taken (i.e., Current TB84 Indication + [Grab Sample Value - TB84 Indication at the time the grab sample was taken]). Use the ▲ Key to increment the digit value and the ► Key to move to the next digit and/or unit of conductivity. Press the ENTER Key to enter the new value.

Invalid new calibration values will generate the text string BAD.CAL, and the calibration value will not be accepted. If the new value is valid, the Slope value will be shown. Pressing the NEXT Smart Key displays the Offset value. At this point, the user can return to the Conductivity/Concentration Calibrate State by pressing the NEXT Key or to the Measure Mode by pressing the Exit To MEASURE Key.

---

## Temperature Calibrate State

---

The Temperature Calibrate State is a smart calibration routine that allows for both single- and dual-point calibration. By calibrating the temperature at two points which are at least 20°C apart, the TB84TE Series analyzer automatically adjusts the offset and/or slope. Since this routine only uses the most recent calibration data, calibrations can be conducted throughout the sensor's life to ensure accurate measurement of the temperature sensing device. If an incorrect calibration has been entered, the Reset Calibrate State can restore the calibration to factory settings. See Reset Calibrate State in this section.

Note: The Reset Calibrate State will reset all calibration values including the process variable and temperature; therefore, process variable and temperature calibrations are required after performing the Reset Calibration procedure.

Conduct a Temperature Calibration using Figure 6-3 and the following procedure:

- 1) Before installing the sensor into its final installed location, allow the sensor to reach ambient temperature.
- 2) Select the Temperature Calibrate State of Operation using the SELECT Key.
- 3) Set the engineering unit by pressing the ▲ Key to toggle the unit between °C (i.e., degrees Celsius) or °F (i.e., degrees Fahrenheit), and press the ENTER Key to use the displayed engineering unit.
- 4) Confirm the displayed reading is STABL? (i.e., stable) using either the YES or NO Key. If the NO Key is pressed, the TB84TE Series analyzer will return to the Temperature Calibrate State. For an unstable condition, conduct one or more of the following steps:
  - a) Wait until the temperature stabilizes,

- b) Check to see if the TB84TE Series analyzer has detected a Fault condition by looking for the Fault icon on the LCD. Interrogate the fault by escaping to the Measure Mode using the Exit to MEASURE Key and the FAULT Info Key in that order.
- c) See Section 14, Troubleshooting.

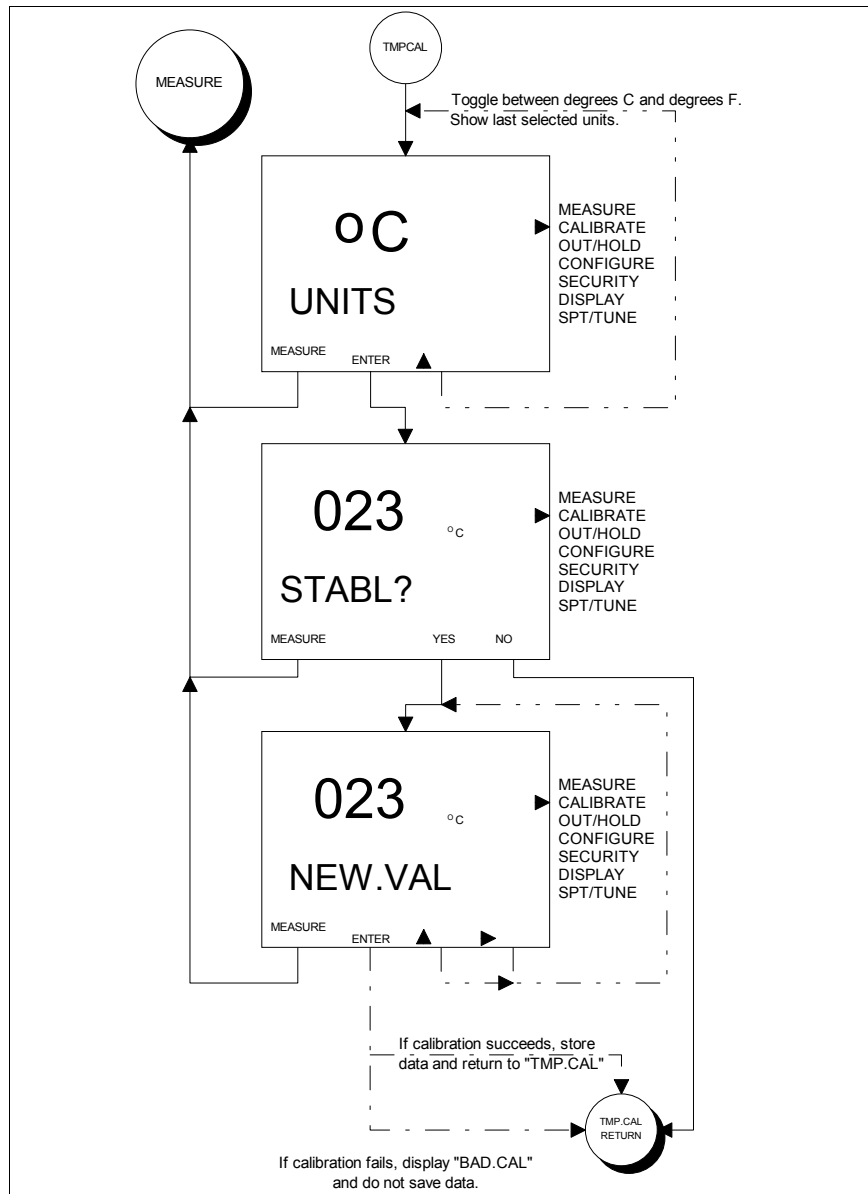

Figure 6-4. Screen Flow Diagram For Temperature Calibrate State of Operation.

- 5) If the reading was stable, enter the NEW VAL (i.e., new temperature value) using

---

the ▲ Key to increment the blinking digit and the ► Key to move to the next digit. Press the ENTER Key to enter the new value.

- 6) Repeat steps 2 through 5 once the sensor has been mounted in its final installed location and the temperature reading has stabilized. Use the process fluid temperature as the NEW VAL.

---

### **Edit Calibrate State**

The Edit Calibrate State allows a user to manually adjust the sensor and temperature slope and offset values. Though this function may not be suitable for many applications, the Edit Calibrate State facilitates quick and easy access to calibration values for troubleshooting purposes.

Conduct an Edit Calibration using the following procedure.

- 1) Select the Edit Calibrate State of Operation using the SELECT Key.
- 2) Edit the sensor PV SLP (i.e., slope) value using the ▲ Key to increment the blinking digit and the ► Key to move to the next digit. Press the ENTER Key to enter the new value or to proceed to the sensor offset value. Press the Exit To MEASURE Key to escape to the Measure Mode. Valid slope values range from 0.20 to 5.00.
- 3) Edit the sensor PV OFF (i.e., offset) value using the ▲ Key to increment the blinking digit and the ► Key to move to the next digit. Press the ENTER Key to enter the new value or to proceed to the temperature slope value. Press the Exit To MEASURE Key to escape to the Measure Mode. Valid offset values are +/- 20  $\mu$ S/cm for cell constants of 1.00, +/- 4  $\mu$ S/cm for cell constants of 0.10, and +/- 0.8  $\mu$ S/cm for cell constants of 0.01.

- 
- 4) Edit the temperature TMP.SLP value using the ▲ Key to increment the blinking digit and the ► Key to move to the next digit. Press the ENTER Key to enter the new value or to proceed to the temperature offset value. Press the Exit To MEASURE Key to escape to the Measure Mode. Valid slope values range from 0.2 to 1.5.
  - 5) Edit the temperature TMP.OFF value using the ▲ Key to increment the blinking digit and the ► Key to move to the next digit. Press the ENTER Key to enter the new value or to proceed to the Edit Calibrate State. Press the Exit To MEASURE Key to escape to the Measure Mode. Valid offset values are +/- 40°C.

---

### **Reset Calibrate State**

The Reset Calibrate State sets all calibration data (i.e., sensor and temperature) to factory values. This state purges calibration history and should be initiated before calibrating a new sensor.

When interrogating the calibration values after a reset has been performed, the slope and offset values for both the process variable and temperature will be set to 1.000 and 0.000, respectively.

Conduct a Reset Calibrate using the following procedure.

- 1) Select the Reset Calibrate State of Operation using the SELECT Key.
- 2) Confirm or refuse the RESET? operation using either the YES or NO Key, respectively.

Note: The Reset Calibration State will reset all calibration values including the process variable and temperature; therefore, process variable and temperatures calibrations are required after performing the Reset Calibration procedure.

---

## Analog Output One & Two Calibrate State

---

The Analog Output One and Two Calibrate State trim their respective output signals to maintain precise transmission of the process variable to the final monitoring system. Though the TB84TE Series analyzer output current is factory calibrated, the output can be trimmed to compensate for other input/output devices.

Conduct an Output Calibration using the following procedure.

- 1) Select the Output Calibrate State of Operation using the SELECT Key.
- 2) Use the ▲ or ▼ Keys to increase or decrease the 1 or 4 milliamper output signal. Press the ENTER Key to enter the new value or to proceed to the 20 milliamper output level.

Note: The 1 milliamper is used as the lower calibration point for 0 to 20 milliamper output configurations.

- 3) Use the ▲ or ▼ Keys to increase or decrease the 20 milliamper output signal. Press the ENTER Key to enter the new value or to proceed to the Output Calibrate State.

Note: If the output level has been adjusted and the adjusted level has been entered using the Enter Key, this adjusted value will be permanently stored. To rectify a bad calibration, the output calibration procedure must be repeated.



---

## SECTION 7 - OUTPUT/HOLD MODE

---

### INTRODUCTION

The Output/Hold Mode of Operation provides the ability to set the outputs to fixed levels and/or states, change the output ranges, damp the output signals, or disable the diagnostic spike.

---

### OUTPUT/HOLD STATES OF OPERATION

The Output/Hold Mode consists of six states of operation. Table 7-1 describes the function of each state of operation.

**Table 7-1. Output/Hold States**

<b>State</b>	<b>Function</b>
HOLD	Used to fix output levels and/or states to values captured when the hold was initiated or to manually entered values, or used to release an existing output HOLD state.
AO1.RNG	Used to change Analog Output One range.
AO2.RNG	Used to change Analog Output Two range.
DAMPNG	Used to reduce fluctuation in the displayed values and/or output signals.
SPIKE	Used to enable or disable the spike output function if configured.

In the Output/Hold Mode, the NEXT Smart Key sequentially moves the user through the other Output/Hold States. The cycle repeats until an Output/Hold State is selected using the SELECT Smart Key or the escape function is chosen using the Exit To MEASURE Smart Key. Use Figure 7-1 to identify Smart Key assignments and the resulting action.

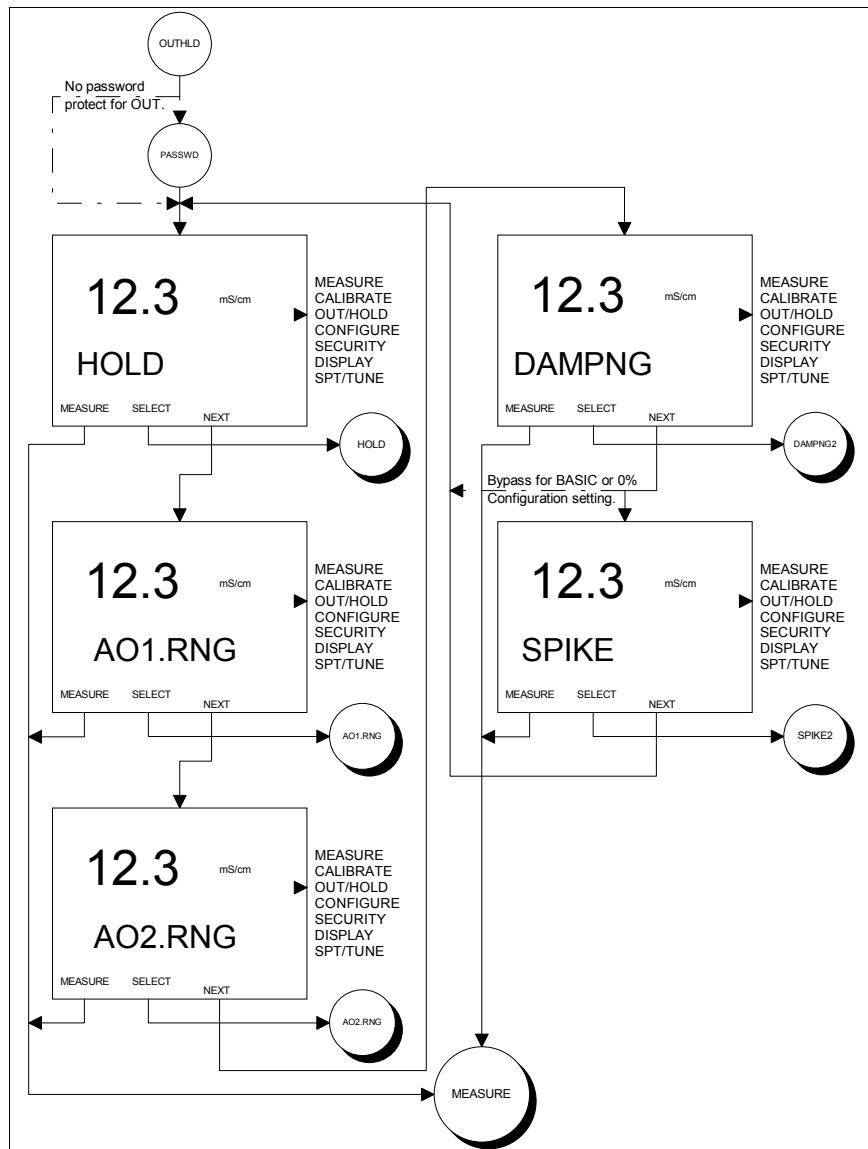

Figure 7-1. Screen Flow Diagram For Output/Hold States of Operation.

The following subsections contain detailed descriptions of each Output/Hold State of Operation.

### Hold/Release Hold Output State

The Hold Output State allows a user to fix the analog and relay outputs to captured levels and states or to manually set the output levels and states. An existing hold condition is removed using this state of operation.

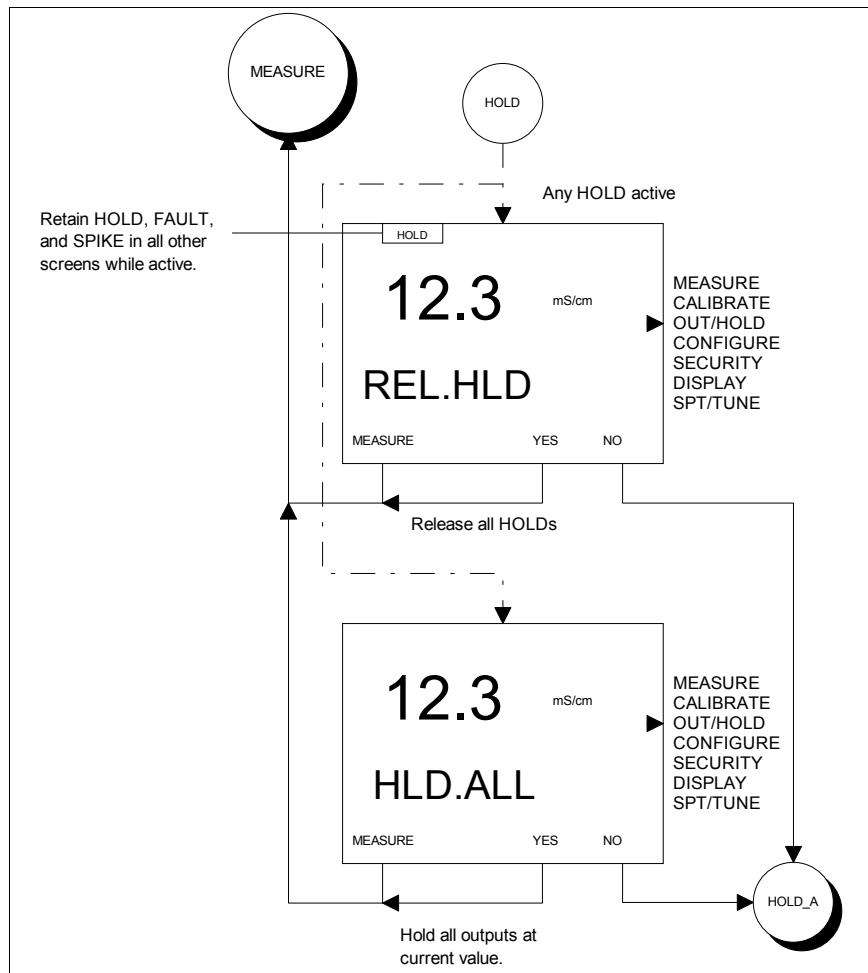

Figure 7-2. Screen Flow Diagram For Hold State of Operation.

As seen in Figure 7-2, a Hold condition is set or removed using the Hold State of Operation. If a Hold condition is not active, the option to Hold All (i.e., HLD.ALL) is given. Confirmation of this action using the YES Key causes the TB84TE Series analyzer to hold all analog and relay outputs at the levels and states captured upon the time of confirmation. If a Hold All or Release Hold action is not confirmed by using the NO Key, each output can be independently held to the capture level/state or to a manually set level/state. Figures 7-3 and 7-4 show the programming prompts, smart key assignments, and resulting actions for manually setting the analog and relay outputs.

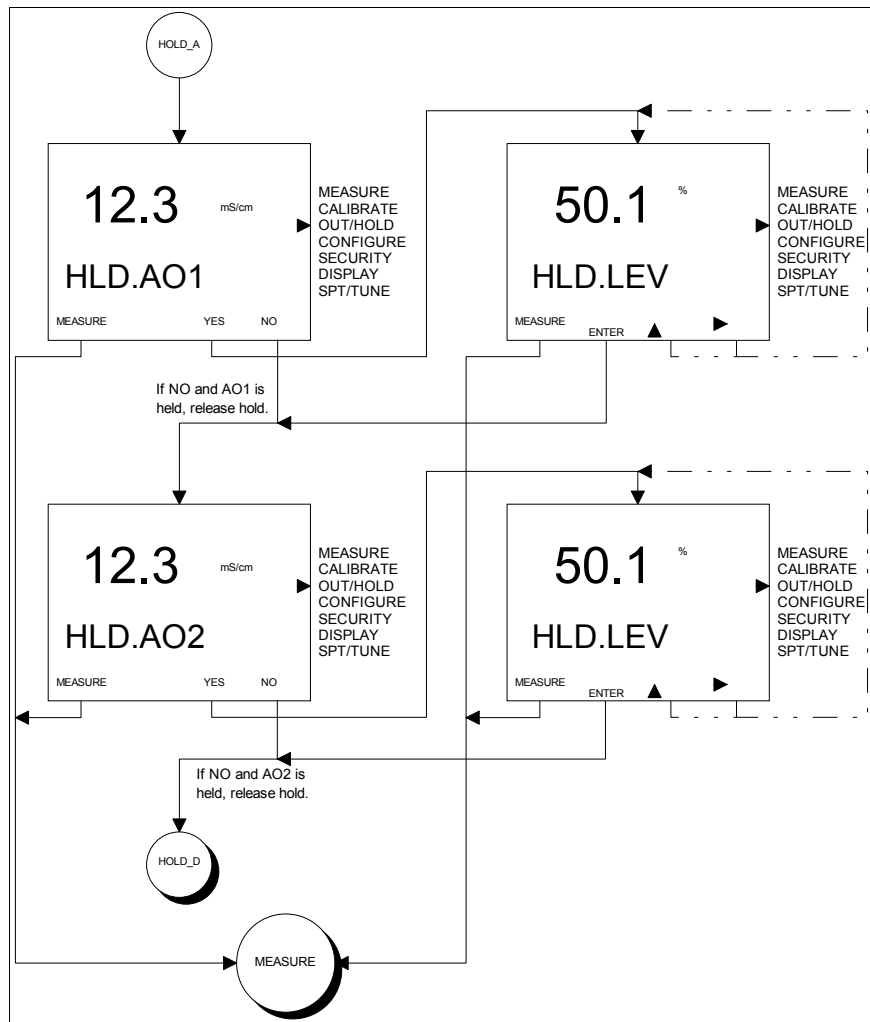

Figure 7-3. Screen Flow Diagram For Setting Specific Analog Output Hold Levels.

As seen by Figures 7-3 and 7-4, any single or combination of analog and relay outputs can be held to any specified level or state. A Hold condition is commissioned using the YES Key and declined using the NO Key. The hold level and/or state is set using the arrow(s) and Enter Keys.

Initiate a Hold Output condition using Figures 7-2, 7-3, and 7-4 as references and the following procedure:

- 1) Select the Hold State of Operation using the SELECT Key.

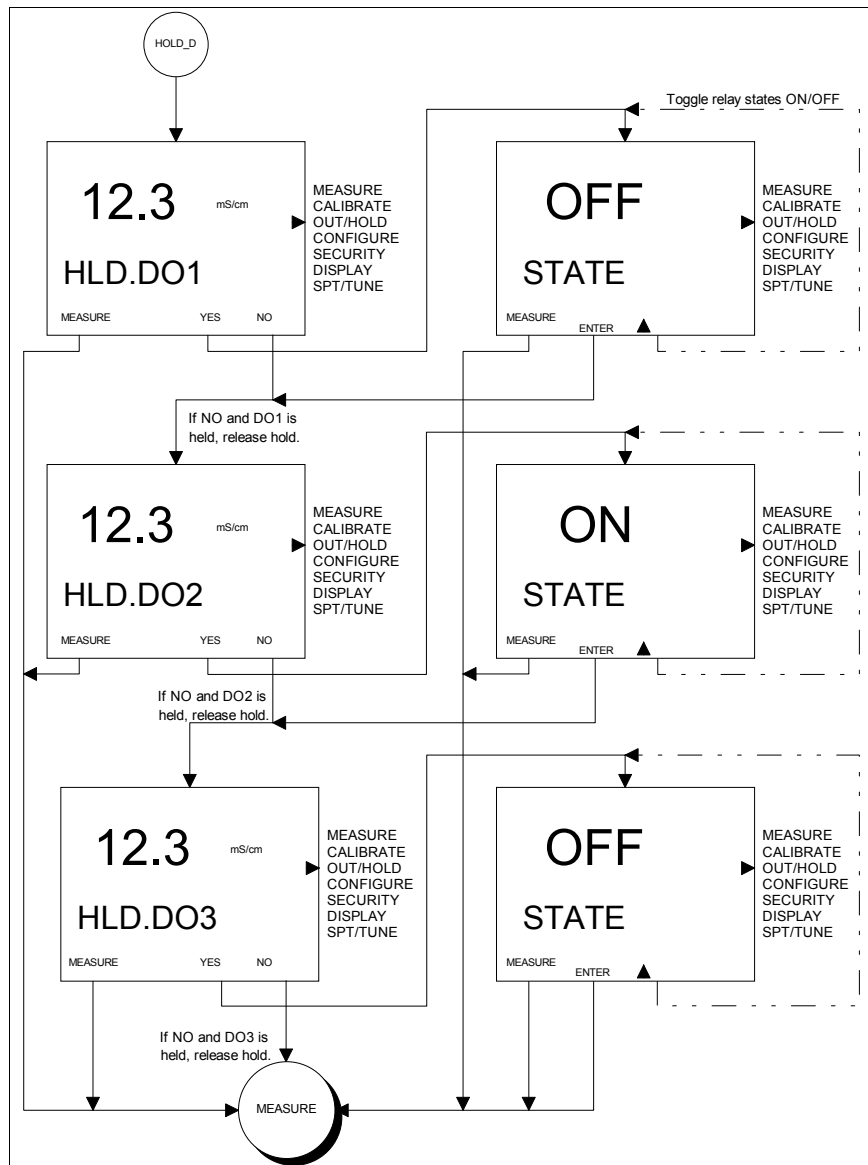

Figure 7-4. Screen Flow Diagram For Setting Specific Relay Output States.

- 2) Hold all (i.e., HLD.ALL) outputs by pressing the YES Key, or hold specific outputs using the NO Key. Press the Exit To MEASURE Key to escape to the Measure Mode.
- 3) For each output, use the YES Key to hold the indicated output or the NO Key to release the indicated output. Press the Exit To MEASURE Key to escape to the Measure Mode.

- 
- 4) For held analog outputs, set the hold value using the ▲ Key to increment the blinking digit and the ► Key to move to the next digit, and press the ENTER Key to enter the new value. Press the Exit To MEASURE Key to escape to the Measure Mode.
  - 5) For held relay outputs, toggle the relay to the desired state (i.e., OFF or ON) using the ▲ Key, and press the ENTER Key to enter the new value. Press the Exit To MEASURE Key to escape to the Measure Mode.

Note: If the YES key was used to commission a hold condition on any output, initiating the escape function will not affect the commissioned Hold condition. To release this Hold condition, the Hold State must be re-entered and the Hold condition released either by using the YES Key when requested to release all hold conditions (i.e., REL.HLD) or by removing the hold condition using the NO Key when individually setting each output.

If a hold condition(s) already exists and the user selects the Hold State of Operation, the TB84TE Series analyzer will request whether all hold conditions should be released (i.e., REL.HLD). Press the YES Key if all hold conditions should be released and the NO Key to edit the existing hold conditions.

---

### **Analog Output One Rerange State**

The Analog Output One Rerange Output/Hold State provides the ability to change the output range of Analog Output One. One or both end point values can be changed to any value or range of values that are within the specifications listed in Table 1-3.

If a non-linear output is configured, reranging the end point values will affect the non-linear relationship. Since the non-linear relationship is set as a percentage input against a percentage output, changing the end point values should accompany a review of the break point relationship. See Section 8, Configure Mode, for information on viewing and modifying the non-linear break points.

---

Conduct a Rerange of the output values using the following procedure:

- 1) Select the Rerange State of Operation using the SELECT Key.
- 2) Edit the process variable value for the zero or four milliampere point (determined by the analyzer's configuration) using the ▲ Key to increment the blinking digit and the ► Key to move to the next digit and press the ENTER Key to enter the new value, or press the ENTER Key to continue to the 20 milliampere value. Press the Exit To MEASURE Key to escape to the Measure Mode.
- 3) Press the ENTER or Exit To MEASURE Key to escape to the Measure Mode, or edit the process variable value for the 20 milliampere point using the ▲ Key to increment the blinking digit and the ► Key to move to the next digit and press the ENTER Key to enter the new value.

**Note: If 1)the zero or four milliampere value is changed, 2)the new value is valid per the specification in Table 1-3, 3)this change is accepted using the Enter Key, and 4)the user escapes to the Measure Mode using the Exit To Measure Key without adjusting the 20 milliampere value, the output range will now reflect the newly entered zero or four milliampere point.**

---

### **Analog Output Two Rerange State**

The Analog Output Two Rerange Output/Hold State provides the ability to change the output range of Analog Output Two. One or both end point values can be changed to any value or range of values that are within the specifications listed in Table 1-3.

Conduct a Rerange of the output values using the following procedure:

- 1) Select the Rerange State of Operation using the SELECT Key.

- 
- 2) Edit the process variable value for the zero or four milliampere point (determined by the analyzer's configuration) using the ▲ Key to increment the blinking digit and the ► Key to move to the next digit and press the ENTER Key to enter the new value, or press the ENTER Key to continue to the 20 milliampere value. Press the Exit To MEASURE Key to escape to the Measure Mode.
  - 3) Press the ENTER or Exit To MEASURE Key to escape to the Measure Mode, or edit the process variable value for the 20 milliampere point using the ▲ Key to increment the blinking digit and the ► Key to move to the next digit and press the ENTER Key to enter the new value.

**Note: If 1)the zero or four milliampere value is changed, 2)the new value is valid per the specification in Table 1-3, 3)this change is accepted using the Enter Key, and 4)the user escapes to the Measure Mode using the Exit To Measure Key without adjusting the 20 milliampere value, the output range will now reflect the newly entered zero or four milliampere point.**

---

## Damping State

The Damping State applies a lag function on the input signal for Basic configuration or can apply different lag functions to the display process variable, Analog Output One, and Analog Output Two for Advanced configurations. The Damping function reduces the fluctuations caused by erratic process conditions. Damping values can be set from 0.0 to 99.9 seconds and represent the time required to reach 63.2% of a step change.

For Basic configurations, the damping value is applied to the analyzer's input signals. In this case, damping will be applied to the displayed process variables and analog outputs. For Advanced configurations, different damping values can be applied to each output element (i.e., the displayed process variables, Analog Output One, and Analog Output Two.)

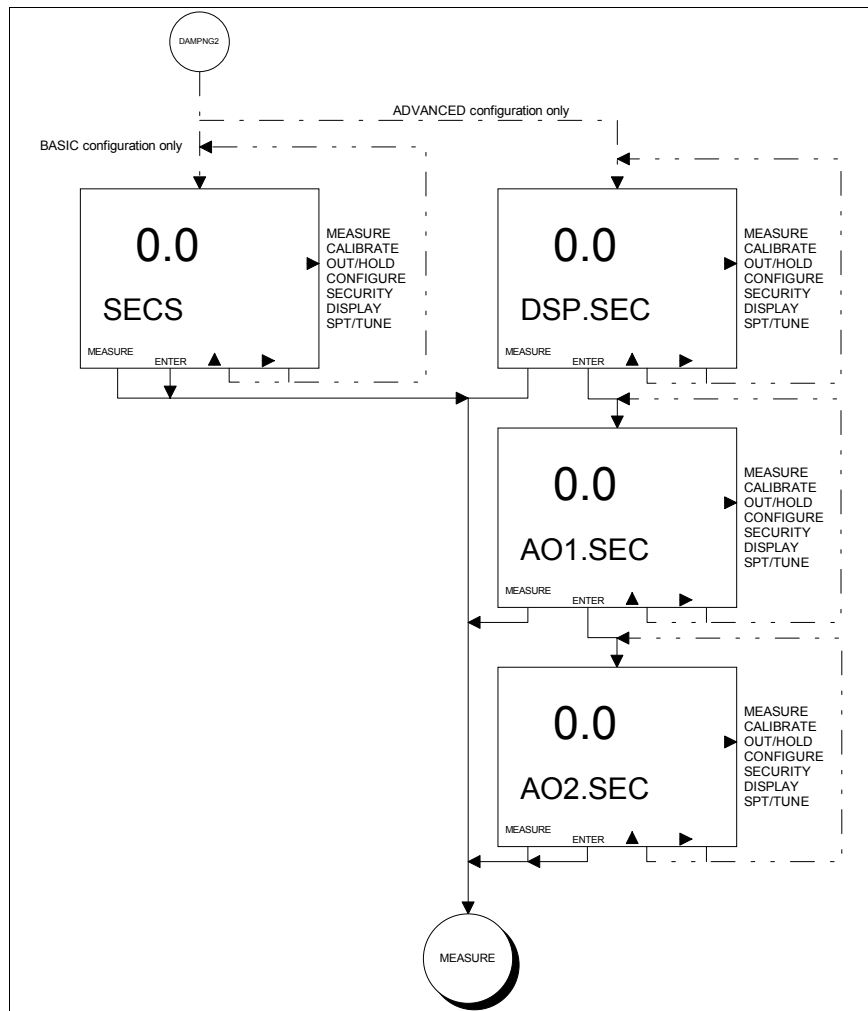

Figure 7-5. Screen Flow Diagram For Output/Hold Damping State

Apply Damping on the outputs using Figure 7-5 as a reference and the following procedure:

- 1) Select the Damping State of Operation using the SELECT Key.
- 2) Edit the new damping value using the ▲ Key to increment the blinking digit and the ► Key to move to the next digit and press the ENTER Key to enter the new value. Press the Exit To MEASURE Key to escape to the Measure Mode.

---

## Spike State

The Spike State toggles the operational state of the spike output function. The spike function modulates the current output on Analog Output One by the amount established in the analyzer configuration. See Section 2, Analyzer Functionality And Operator Interface Controls, and Section 8, Configure Mode, for more information.

Toggle the Spike output using the following procedure:

- 1) Select the Spike State of Operation using the SELECT Key.
- 2) Toggle the spike output function to the desired state (i.e., OFF or ON) using the ▲ Key, and press the ENTER Key to accept the displayed state. Press the Exit To MEASURE Key to escape to the Measure Mode.

**Note: Once the Spike State is OFF, changing the configured spike level in the Configure Mode will not re-enable the Spike State. The Spike State can only be turned ON or OFF in the Output/Hold Mode of Operation.**

---

## SECTION 8 - CONFIGURE MODE

---

### INTRODUCTION

The Configure Mode of Operation establishes the operating parameters of the TB84TE Series analyzer. These parameters include programming mode, analyzer type, sensor cell constant value, temperature compensation type, analog output ranges, relay output parameters, damping value(s), diagnostic functionality, safe mode levels, and spike magnitude (i.e., level).

A description of each configuration item and related parameters will be included. Review each of the following sections before configuring the TB84TE Series analyzer.

---

### PRECONFIGURATION DATA REQUIRED

Before attempting to configure the TB84TE Series analyzer, the following requirements must be defined.

1. Analyzer parameters.
2. Analog Output Range values.
3. Relay Output function and parameters.
4. Security requirements.
5. Sensor Diagnostic functionality.

Use the worksheets found in Appendix D to help establish the proper settings for any given application. Use these sheets during the configuration entry procedure and retain them as a historical record for future reference.

---

### CONFIGURE VIEW/MODIFY STATE

Upon selecting the Configure Mode of Operation, a decision point is reached to Modify or View the configuration of the TB84TE Series analyzer. The Modify Configure State enables analyzer options to be set and saved into memory. In order to provide the ability to secure the Modify Configure State yet leave

the ability to view configuration information, the View Configure State can be entered without using a security code.

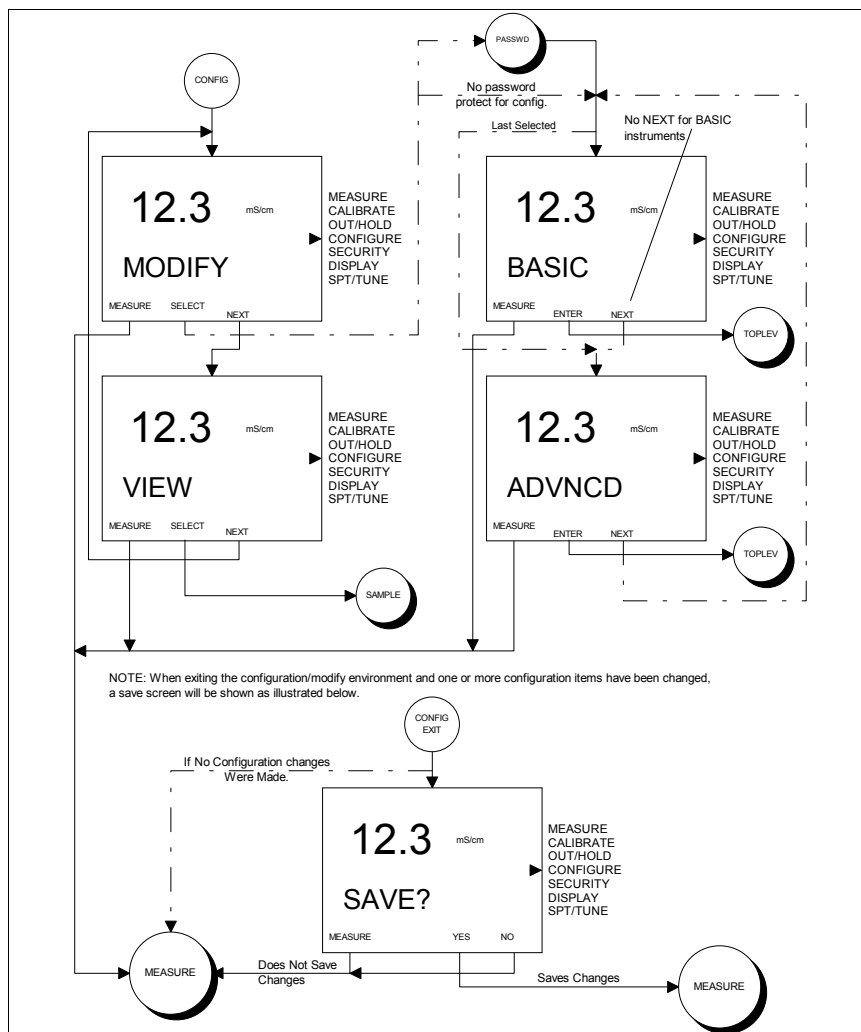

Figure 8-1. Screen Flow Diagram For Modify/View and Basic/Advanced Configure States of Operation.

As seen in Figure 8-1, the TB84TE Series analyzer queries if the user would like to Modify the configuration. Pressing the YES Smart Key moves the user into the Modify Configure State, pressing the NO Smart Key moves the user to the View configuration query, and pressing the Exit To MEASURE Smart Key escapes to the Measure Mode.

---

If a configuration requires modification and the user is in the View Configure State, access to the Modify Configure State is provided through a HotKey function. The HotKey links the View Configure State to the Modify Configured State using the ENTER Smart Key. For example, the TMP.SNS (i.e., temperature sensor) in the View Configure State can be modified from PT 100 to None by pressing the ENTER Smart Key when viewing the PT 100 option. An intermediate confirmation screen will query the user on their desire to modify this option using the YES or NO Smart Keys. If the Modify Configure State has been secured, the security code will be requested. Upon entering the correct code or if the Modify Configure State has not been secured, the TB84TE Series analyzer will go directly to TMP.SNS Modify Configure State and allow the user to change the type of temperature sensor. After completing the change, pressing Exit To MEASURE Smart Key moves the user to the configuration SAVE? State. Pressing the YES Smart Key saves the new temperature sensor option and returns the analyzer to the Measure Mode.

---

#### **BASIC/ADVANCED PROGRAMMING MODE**

The Configure Mode is split into two programming modes: Basic and Advanced. These two options are specified by nomenclature and control the number of configuration options available in the Modify Configure State.

The Basic Programming Mode contains a subset of configuration options found in the Advanced mode. Separation into two programming groups is advantageous when limited functionality is desired. Fewer options reduces confusion and the possibility of configuration errors.

When Advanced programming is ordered, the programming toggle (i.e., Basic/Advanced) must be set in two locations: the User State in the Utility Mode and the Modify Configure State in the Configure Mode. In order to select either the Basic or Advanced Programming Mode in the Modify Configure State, the Programming Mode must be set to Advanced in the User State.

---

See Section 12, Utility Mode, for more information on setting the User State programming mode to Advanced.

When in the Configure Mode and Advanced programming has been set in the User State, the TB84TE Series analyzer queries if the user would like Basic programming. Pressing the ENTER Smart Key moves the user to the Modify Configure States, pressing the NEXT Smart Key moves the user to the Advanced programming query, and pressing the Exit To MEASURE Smart Key escapes to the Measure Mode. To set the analyzer to Advanced programming, the user presses the ENTER Smart Key when queried to set the programming to Advanced. See Figure 8-1 for the corresponding screen flows.

---

## **MODIFY CONFIGURE STATES OF OPERATION**

Since the View Configure State only displays the configured options, the following sections will strictly focus on each Modify Configure State and the available options for these states.

The Modify Configure State contains all the available settings that establishes the functionality of the TB84TE Series analyzer. Upon receipt of the analyzer, the default configuration (unless otherwise specified by the customer when ordering the TB84TE Series analyzer) will be used once the analyzer has been powered. See the Preface for the default configuration settings.

Before installing the analyzer, the configuration should be modified to reflect the final installed application. The Modify Configure States define the analyzer type, sensor types, output parameters, and diagnostic functionality. Table 8-1 describes each of these programming modes and their function.

**Table 8-1. Modify Configure States**

<b>State</b>	<b>Function</b>	<b>Programming Mode</b>
ANALZER	Used to define the type of analyzer. Choices include Conductivity (COND) and Concentration (CONCEN).	Basic: Conductivity Advanced: All Options
TMP.SNS	Used to define the type of temperature sensor. Choices include None, Pt100, Pt1000, and 3k Balco.	Basic/Advanced
TC.TYPE	Used to define the type of temperature compensation. Choices include Manual (0.1N KCl based), and Automatic which can be set to one of the following: Standard KCl (0.1N KCl based), Temperature Coefficient (%/°C based), Pure Water Neutral, Pure Water Acid, Pure Water Base, and User-Defined.	Basic/Advanced
AO1.OUT	Used to set Analog Output One range.	Basic/Advanced
AO2.OUT	Used to set Analog Output Two range.	Basic/Advanced
RELAY1	Used to set Relay Output One function and parameters. Choices include Setpoint, Cycle Timer, Diagnostics, and Cleaner.	Basic/Advanced
RELAY2	Used to set Relay Output Two function and parameters. Choices include Setpoint, Cycle Timer, Diagnostics, and Cleaner.	Basic/Advanced
RELAY3	Used to set Relay Output Three function and parameters. Choices include Setpoint, Cycle Timer, Diagnostics, and Cleaner.	Basic/Advanced
DAMPNG	Used to reduce fluctuation in the display values and output signals.	Basic/Advanced
DIAGS	Used to set the sensor diagnostics ON or OFF.	Basic/Advanced
SAF.MD.1	Used to define the output signal state for Analog Output One when a detected error results in a condition that renders the analyzer inoperable. Choices include fail Low or fail High.	Basic/Advanced
SAF.MD.2	Used to define the output signal state for Analog Output Two when a detected error results in a condition that renders the analyzer inoperable. Choices include fail Low or fail High.	Basic/Advanced
SPIKE	Used to set the spike magnitude level.	Advanced

As with the other modes and states of operation, the NEXT Smart Key provides access to all Modify Configure States. Pressing the NEXT Smart Key sequentially moves the user through each state. This cycle repeats until a Modify Configure State is selected using the SELECT Smart Key or the escape function is chosen using the Exit To MEASURE Smart Key. Use Figure 8-2 and 8-3 to identify the Smart Key assignments and the resulting action.

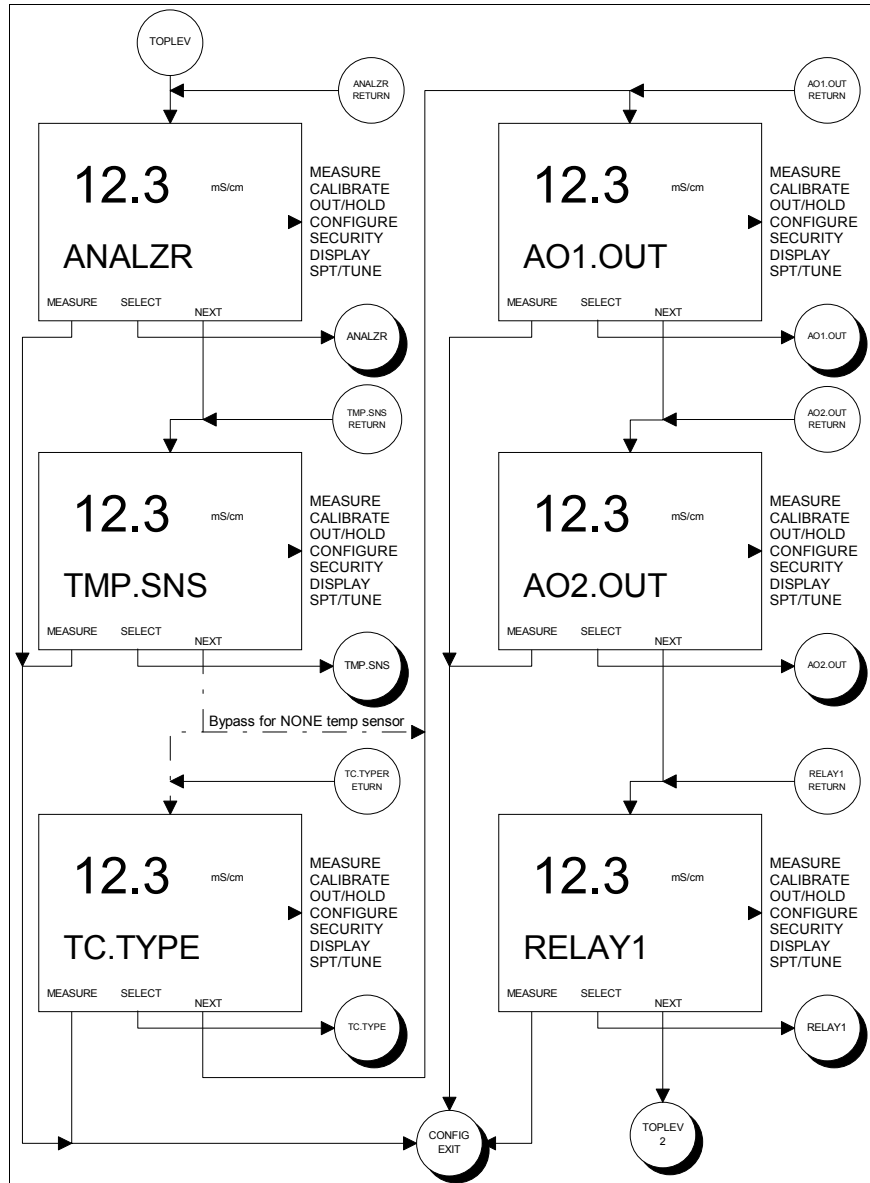

Figure 8-2. Screen Flow Diagram For Modify Configure States of Operation - Part One.

When selecting a Modify Configure State, the configured (i.e., active) item within that state will be the first item shown. This item will remain the configured item until a new item is entered and the configuration saved.

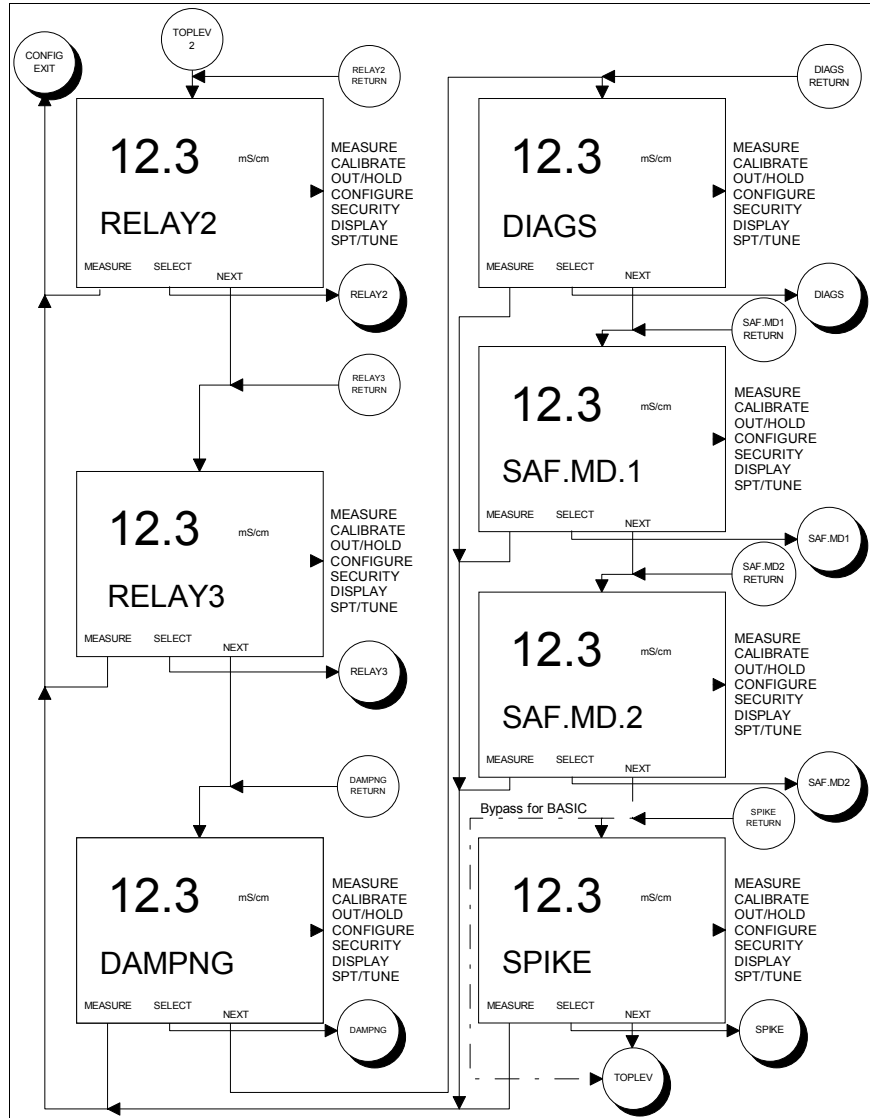

Figure 8-2. Screen Flow Diagram For Modify Configure States of Operation - Part Two.

The following subsections contain detailed descriptions of each Modify Configure State of Operation.

---

**Analyzer State (Basic/Advanced)**

---

The Analyzer State determines the type of analyzer and sensor. Table 8-2 describes the function and programming mode of each state.

**Table 8-2. Analyzer States**

<b>State</b>	<b>Function</b>	<b>Programming Mode</b>
Conductivity	Used to measure the conductivity of a solution. Process variable engineering units are mS/cm and $\mu$ S/cm.	Basic/Advanced
Concentration	Used to measure the conductivity of a solution and convert this non-specific measurement to a specific solute concentration. Process variable engineering units are %, ppm, ppb, and user-defined.	Advanced

---

**Conductivity Analyzer State (Basic/Advanced)**

---

The Conductivity Analyzer State requires information on the sensor cell constant. This constant must be entered and correspond with the range specified in Table 1-3. Since two-electrode conductivity sensors can vary significantly from one vendor to the next, only ABB Two-Electrode Conductivity Sensors are recommended for use with the TB84TE Series transmitter.

Configure a Conductivity Analyzer State using the following procedure:

- 1) Select the ANALZR (i.e., Analyzer) State in the Configure Mode of Operation using the SELECT Key.
- 2a) If the Programming Mode is set to Basic, the TB84TE Series analyzer goes directly to the sensor Cell Constant State. Skip to step 3.

---

2b) If the Programming Mode is set to Advanced, choose the COND State by using the NEXT Key to toggle between COND and CONCEN (i.e., Conductivity and Concentration, respectively). Once the correct option is display, press the ENTER Key to accept the choice.

**Note: CONCEN State is only available when the Advanced Programming State has been purchased and selected. See Section 12, Utility Mode, for Programming Mode selection.**

3) Edit the sensor cell constant value using the ▲ Key to increment the blinking digit and the ► Key to move to the next digit. Press the ENTER Key to enter the new value.

---

### **Concentration State (Advanced)**

The Concentration State converts conductivity values to concentration units. This state applies temperature-compensated conductivity measurements to a pre-defined or user-defined function that converts the conductivity measurements to concentration values having a fixed decimal point location (i.e., automatic decimal point ranging is not supported).

The user-defined configuration provides capability for selecting an Engineering Unit icon, decimal point position, custom text description, and six-point linear curve fit. The Engineering Unit icon options include percent (i.e., %), parts-per-million (i.e., ppm), parts-per-billion (i.e., ppb), and no Engineering Unit icon.

The six-point linear curve fit sets the end-point and break-point values of the desired conductivity-to-concentration conversion. The end-point values define the full-scale output range, and the break-points identify the transition points between the five line segments that define the conductivity-to-concentration curve.

To define the end- and break-point values, a plot of temperature-compensated conductivity against solute concentration must be divided into five line segments that best approximate the shape of the conductivity-to-concentration curve. The beginning of the first and end of the fifth line segment identify the end-point values of the linear approximation and output range.

Table 8-3 and Figure 8-3 show example data and the linear approximation. As can be seen by this example, the conductivity-to-concentration curve is a non-linear function which has been divided into five line segments. The end-points represent Point Numbers 1 and 6, while the break-points represent Point Numbers 2 through 5. Also note, the analyzer output is linear relative to the solute concentration. Since the end-points (i.e., Point Numbers 1 and 6) define the full-scale output range, rerange of the output values is restricted to the range between Point Numbers 1 and 6. For more information, see Appendix B, Concentration Programming.

**Table 8-3. Non-linear Output Example Values**

<b>Point Number</b>	<b>Conductivity (<math>\mu\text{S}/\text{cm}</math>)</b>	<b>Concentration (%)</b>	<b>Output (mA)</b>
1	0	0	4.0
2	55	5	5.8
3	105	9	7.2
4	195	16	9.7
5	310	28	14.0
6	400	45	20.0

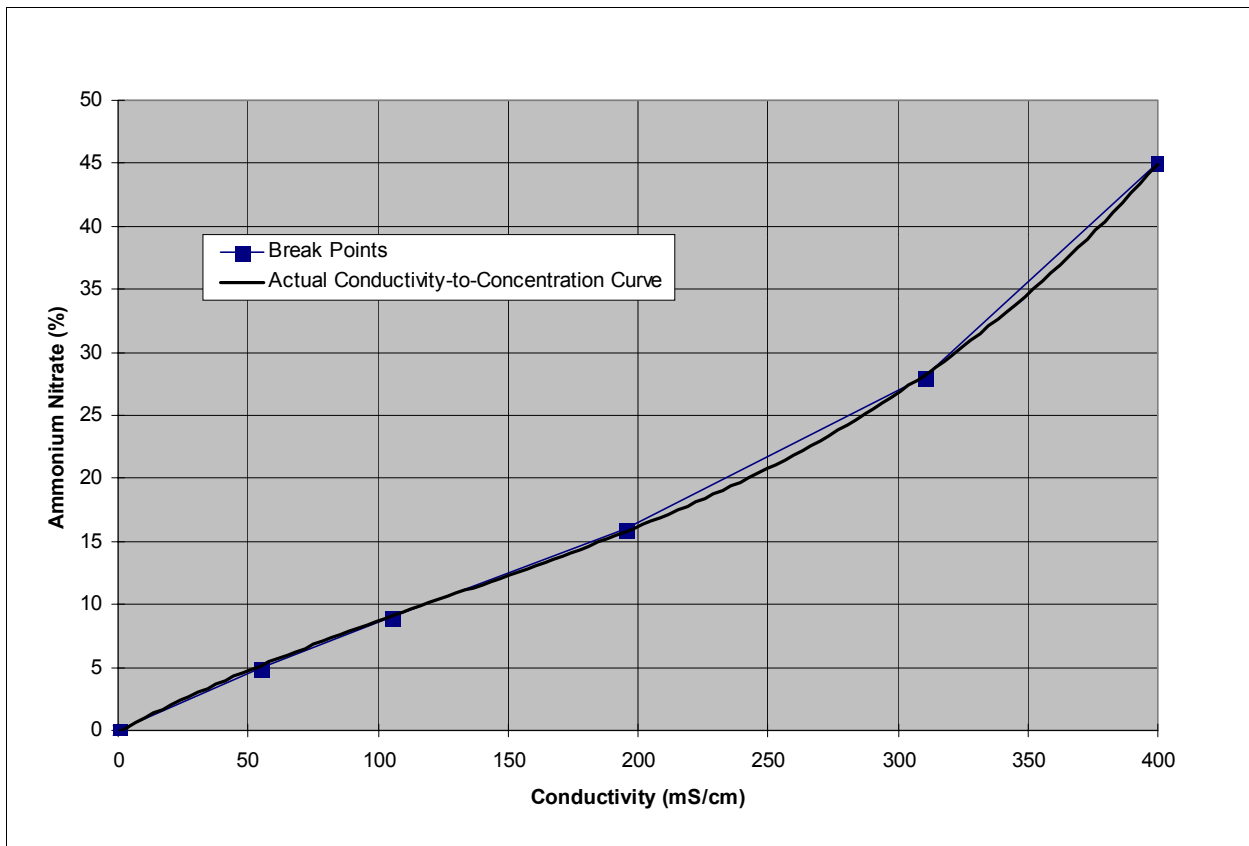

Figure 8-3. Conductivity-to-Concentration Break-Point Determination.

Configure a Concentration Analyzer State using the following procedure.

- 1) Select the ANALZR (i.e., Analyzer) State in the Configure Mode of Operation using the SELECT Key.
- 2) Choose the CONCEN State by using the NEXT Key to toggle between COND and CONCEN (i.e., Conductivity and Concentration, respectively). Once the correct option is displayed, press the ENTER Key to accept the choice.

**Note: CONCEN State is only available when the Advanced Programming State has been purchased and selected. See Section 11, Utility Mode, for Programming Mode selection.**

- 
- 3) Edit the sensor cell constant using the ▲ Key to increment the blinking digit and the ► Key to move to the next digit. Press the ENTER Key to enter the new value.
  - 4) Choose one of the four icon options (i.e., %, ppm, ppb, and NO.ICON) using the NEXT Key. Once the correct option is displayed, press the ENTER Key to accept the choice.
  - 5) Choose the decimal point location by using the ▲ Key to move the blinking decimal point to the next location. Press the ENTER Key to set the decimal point location.
  - 6) Set the text string by using the ▲ Key to increment the character and the ► Key to move to the next character, and press the ENTER Key to enter the text string.
  - 7) Set the end-point conductivity value (i.e., X1.COND) by using the ▲ Key to increment the blinking digit and the ► Key to move to the next digit. Press the ENTER Key to enter the value.
  - 8) Set the end-point concentration value (e.g., Y1.CONC) that represents the end-point conductivity value entered in step 7 by using the ▲ Key to increment the blinking digit and the ► Key to move to the next digit. Press the ENTER Key to enter the value.
  - 9) Set the next four break-point values (i.e., X2.COND/Y2.CONC, X3.COND/Y3.CONC, etc.) using the same technique described in steps 7 and 8.
  - 10) Set the final end-point values (i.e., X6.COND/Y6.CONC) using the same technique described in steps 7 and 8.

---

## Temperature Sensor State (Basic/Advanced)

The Temperature Sensor State configures the temperature input for a Pt100, Pt1000, 3 kohm Balco, or none. When the "NONE" option is entered, the temperature and temperature compensation will be fixed at 25°C and MANUAL, respectively. To change the fixed temperature, a temperature calibration to the desired temperature value is required.

Set the Temperature Sensor State using the following procedure.

- 1) Select the TMP.SNS (i.e., Temperature Sensor) State in the Configure Mode of Operation using the SELECT Key.
- 2) Choose the desired temperature sensor by using the NEXT Key to toggle between NONE, 3K.BLCO (i.e., 3 kohm Balco), PT100, and PT1000. Enter the option by using the ENTER Key when the correct choice is displayed in the secondary display.

---

## Temperature Compensation State (Basic/Advanced)

Temperature has a marked effect on the conductance of many solutions. The effect is generally nonlinear and dependent on the types of ions and their concentration.

The TB84TE Series analyzer contains a number of preprogrammed correction algorithms that compensate for the effect of temperature on conductivity (See Table 8-5). For the Basic Programming Mode, the conductivity reference temperature is fixed to 25°C. For the Advanced Programming Mode, the reference temperature can be set to values other than 25°C. Valid reference temperature values are limited to the Specifications found in Section 1, Introduction.

The options for temperature compensation are grouped into two sets: MANUAL and AUTO (i.e., Automatic). MANUAL temperature compensation does not contain any additional options and is locked to a specific process temperature

independent of the selected temperature sensor. If a different process temperature is desired, the new temperature can be set using a temperature calibration and will be used to temperature compensate the process variable to the reference temperature.

The AUTO compensation options are cell constant dependent and use the temperature values measured by the input from the temperature sensor. Within the AUTO State, compensation algorithms include Standard KCl (0.1N KCl based), Solution Coefficient, Pure Water Neutral, Pure Water Acid, Pure Water Base, and User-Defined.

The User-Defined temperature compensation option requires uncompensated conductivity data from the reference temperature of 25°C to the maximum process temperature using a representative sample of the process solution. With this data, the ratio of uncompensated conductivity to conductivity at the reference temperature of 25 C is calculated. These ratios are plotted against the temperature. If a different reference temperature is desired, the new reference temperature can be entered after entering the ratio data referenced at 25°C, or the reference temperature can remain at 25°C if the entered ratio data is referenced at the desired reference temperature.

**Table 8-4. User-Defined Temperature Compensation Example**

<b>Temperature (°C)</b>	<b>Uncompensated Conductivity (mS/cm)</b>	<b>Conductivity Ratio (K/K<sub>STD</sub>)</b>
0	7.21	0.70
25	10.30	1.00
50	12.25	1.19
75	12.97	1.26
100	12.82	1.24
200	9.06	0.88

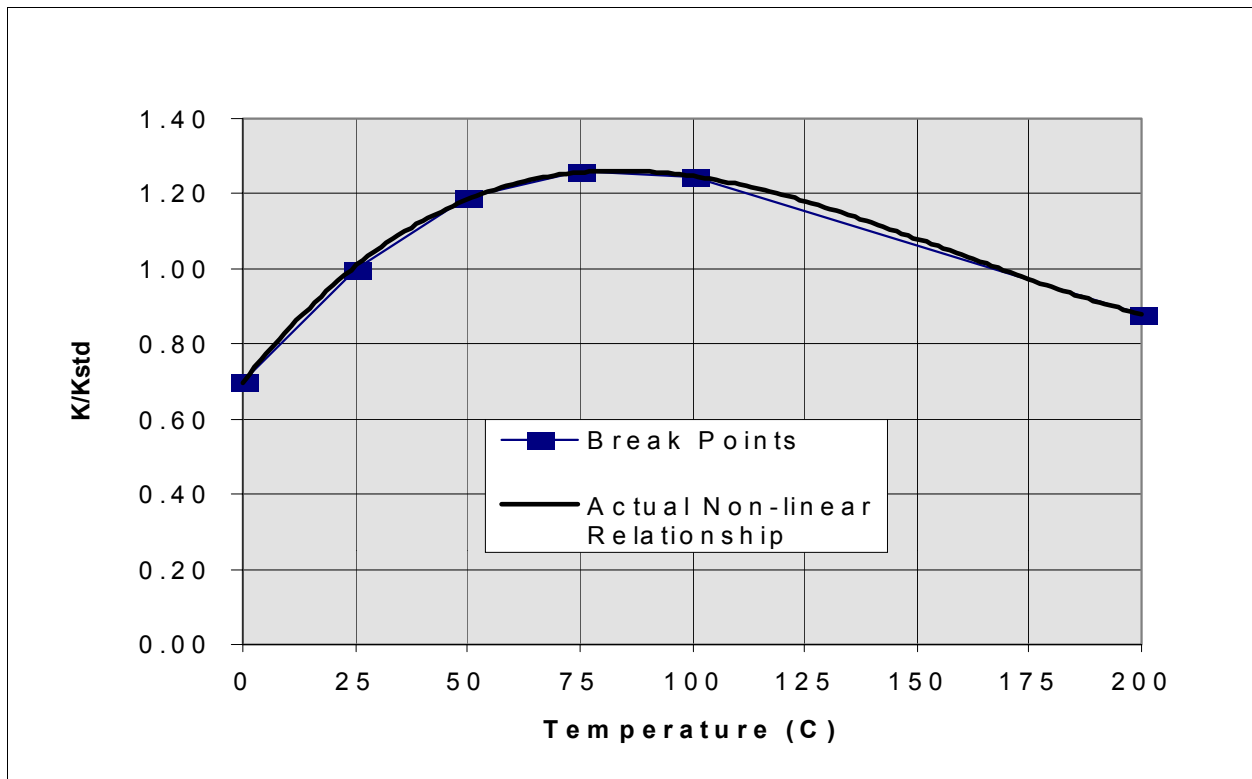

Figure 8-4. User-Defined Temperature Compensation Break-Point Determination.

Table and Figure 8-4 show an example of a typical user-defined temperature compensation plot. As seen in this example, the non-linear plot is segmented into five linear sections. The points (i.e., columns 1 and 3 of Table 8-4) in each row are used to define the break-points for the user-defined temperature compensation option. Each set of point are entered in sequence from the lowest to the highest (e.g., 0 C/0.70 for TMP1 C/K1/K25, 25 C/1.00 for TMP2 C/K2/K25, ..., 200 C/0.88 for TMP6 C/K6/K25).

Table 8-5, Temperature Compensation States, lists the temperature compensation options, their functions, and the Programming Modes in which they are available.

**Table 8-5. Temperature Compensation States**

<b>State</b>	<b>Function</b>	<b>Programming Mode</b>
MANUAL	Used when a fixed temperature value can be used instead of a measured value. The initial value is set at 25°C. Use the Temperature Calibrate State to change the fixed temperature value. Compensation is 0.1N KCl based.	Basic/Advanced
STD.KCL (AUTO)	Used when a measured temperature value is being provided by a temperature sensor. Compensation is 0.1N KCl based.	Basic/Advanced
TC.COEF (AUTO)	Used when a measured temperature value is being provided by a temperature sensor. Compensation is based on a percent change of the conductivity at the reference temperature (e.g., 25°C) per degree Celsius.	Basic/Advanced
NEUTRL (PUR.H2O) (AUTO)	Used when a measured temperature value is being provided by a temperature sensor. Compensation is pure water with a neutral salt based. This option is restricted to Sensor Cell Constant 0.01.	Advanced
ACID (PUR.H2O) (AUTO)	Used when a measured temperature value is being provided by a temperature sensor. Compensation is pure water with an acid based. This option is restricted to Sensor Cell Constant 0.01.	Advanced
BASE (PUR.H2O) (AUTO)	Used when a measured temperature value is being provided by a temperature sensor. Compensation is pure water with a base based. This option is restricted to Sensor Cell Constant 0.01.	Advanced
USR.DEF (AUTO)	Used when a measured temperature value is being provided by a temperature sensor. Compensation is defined as a ratio of uncompensated conductivity over compensated conductivity for a specific set of temperatures.	Advanced

Set the Temperature Compensation State using the following procedure.

- 1) Select the TC.TYPE (i.e., Temperature Compensation Type) State in the Configure Mode of Operation using the SELECT Key.
- 2) Enter the desired temperature compensation group by using the NEXT Key to toggle between MANUAL and AUTO. Press the ENTER Key to accept the choice.

- 
- 3a) For MANUAL compensation, the TB84TE will return to the TC.TYPE State for Basic Programming Modes or RF.TMP.C (i.e., Reference Temperature in °C) for Advanced Programming Modes.
  - 3b) For AUTO compensation, choose one of the compensation options using the NEXT Key. Once the correct option is displayed, press the ENTER Key to accept the choice.
  - 4) For the TC.COEFF (i.e., Temperature Compensation Coefficient) option, set the coefficient value by using the ▲ Key to increment the blinking digit and the ► Key to move to the next digit. Press the ENTER Key to enter the value.
  - 5a) For the USR.DEF (i.e., User-Defined) option, enter the TMP1 C (i.e., Temperature point 1 in degrees Celsius) by using the ▲ Key to increment the blinking digit and the ► Key to move to the next digit. Press the ENTER Key to enter the value and continue onto the ratio entry state.
  - 5b) Enter the K1/K25 (i.e., Conductivity point 1 to Conductivity at the reference temperature of 25 C ratio) by using the ▲ Key to increment the blinking digit and the ► Key to move to the next digit. Press the ENTER Key to enter the value.
  - 5c) Repeat steps 5a and 5b for the remaining five points.
  - 6) For Advanced Programming Modes, enter a new reference temperature value by using the ▲ Key to increment the blinking digit and the ► Key to move to the next digit. Press the ENTER Key once the new value has been entered or press the ENTER Key to accept the default value of 25 C.

---

## **Analog Output One State (Basic/Advanced)**

The Analog Output One State sets the output span, range, and function. The output span is software selectable for either zero to 20 milliamperes or four to 20 milliamperes and is sourced to the Primary Process Variable. For Basic configurations, the output function can only be linear. Lower and upper range values are defaulted to the full scale process variable range and can be changed to any set of values conforming to Table 3-1, Specifications. For Advanced configurations, the output function can be linear or non-linear. For a non-linear output, lower and upper range values must also be set as well as five break point values.

---

## **Linear Output State (Basic/Advanced)**

The Linear Output State establishes the lower and upper range values. The default values for the output represent the full scale process variable range. See Table 1-3, Specifications, for full scale variable ranges.

For a reverse acting output, reverse the zero or four and 20 milliamperes values (e.g., 19.99 mS/cm for the zero or four milliamperes value and 0 mS/cm for the 20 milliamperes value).

Set the Linear Output State using Figure 8-5 as a reference and the following procedure:

- 1) Select the A01.OUT State in the Configure Mode of Operation using the SELECT Key.
- 2) Set the output span using the NEXT Key to toggle between 4-20MA and 0-20MA, and press the ENTER Key to enter the desired span.
- 3) Set the process variable value for the 0 or 4 milliamperes point using the ▲ Key to increment the blinking digit and the ► Key to move to the next digit, and press the ENTER Key to enter the desired value.

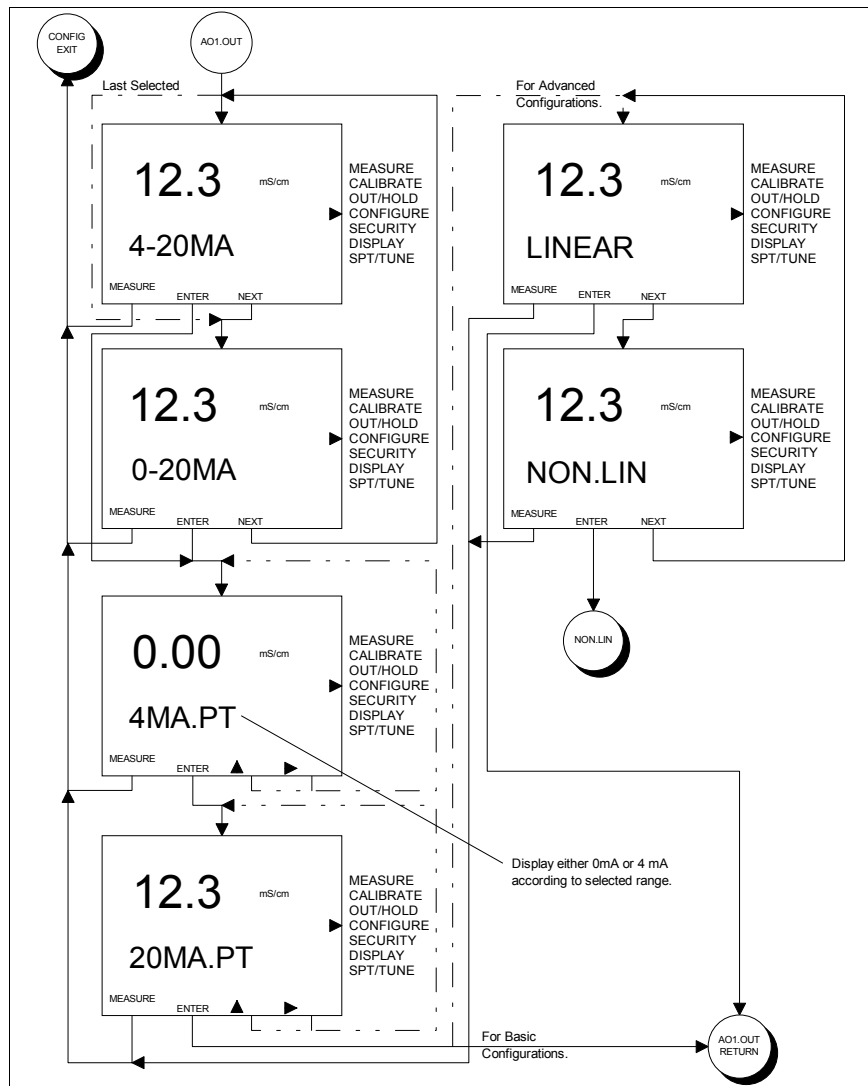

Figure 8-5. Screen Flow Diagram For Analog Output One Configure State of Operation.

- 4) Set the process variable value for the 20 milliampere point using the ▲ Key to increment the blinking digit and the ► Key to move to the next digit, and press the ENTER Key to enter the desired value.
- 5) Select the LINEAR Output State using the SELECT Key for Advanced configurations. For Basic configurations, this step will not be accessible.

---

---

### **Non-Linear Output State (Advanced)**

The Non-Linear Output State sets the end point and break point values for a non-linear output function. The default values for the output range represent the full scale process variable range (e.g., 0 to 19.99 mS/cm). The default break points are set for a linear output (e.g., 20% input equals 20% output).

To define the break point values, a plot of the process variable against the desired output (or variable that represents the output value) must be segmented into six linear regions that best fit the non-linear relationship. The points where the linear regions intersect should fall on the non-linear function and represent the break points that are entered into Non-Linear Output State.

As with the Linear Output State, the output range must be defined and will represent the 0% input/0% output and 100% input/100% output points. Since the 0% and 100% points are defined by the output range, the break point information (e.g., X-1/Y-1, X-2/Y-2, etc. values) should not include the 0% input/0% output and 100% input/100% output values. The break points must be entered as percentage of input range and output span. Also as with a linear output, a reverse acting non-linear output can be implemented by reversing the zero or four and 20 milliampere process variable and break point values (e.g., 199.9 mS/cm for the 0 or 4 milliampere value and 0 mS/cm for the 20 milliampere value).

Set the Analog Output One Non-Linear State using Figure 8-5 as a reference and the following procedure:

- 1) Select the A01.OUT State in the Configure Mode of Operation using the SELECT Key.
- 2) Set the output span using the NEXT Key to toggle between 4-20MA and 0-20MA, and press the ENTER Key to enter the desired span.

- 3) Set the process variable value for the zero or four milliampere point using the ▲ Key to increment the blinking digit and the ► Key to move to the next digit, and press the ENTER Key to enter the desired value.
- 4) Set the process variable value for the 20 milliampere point using the ▲ Key to increment the blinking digit and the ► Key to move to the next digit, and press the ENTER Key to enter the desired value.
- 5) Select the NON.LIN Output State by using the NEXT Key to change the programming state from LINEAR to NON.LIN and pressing the SELECT Key to accept the NON.LIN Output State.
- 6) Set the input percentage for the first break point (X-1) using the ▲ Key to increment the blinking digit and the ► Key to move to the next digit, and press the ENTER Key to enter the new value.
- 7) Set the output percentage for the first break point (Y-1) using the ▲ Key to increment the blinking digit and the ► Key to move to the next digit, and press the ENTER Key to enter the new value.
- 8) Repeat steps 6 and 7 for the remaining four break points.

**Table 8-5. Non-linear Output Example Values**

Break Point	Conductivity (µS/cm)	Output Range (mA)	Percent Input (%)	Percent Output (%)
	0	4.0	0	0
1	120	5.6	20	10
2	270	8.8	45	30
3	360	12.0	60	50
4	420	15.2	70	70
5	540	19.2	90	95
	600	20.0	100	100

Table 8-5 and Figure 8-6 illustrate the use of the Non-linear Output function. This information is only for illustration purposes and does not characterize any specific application.

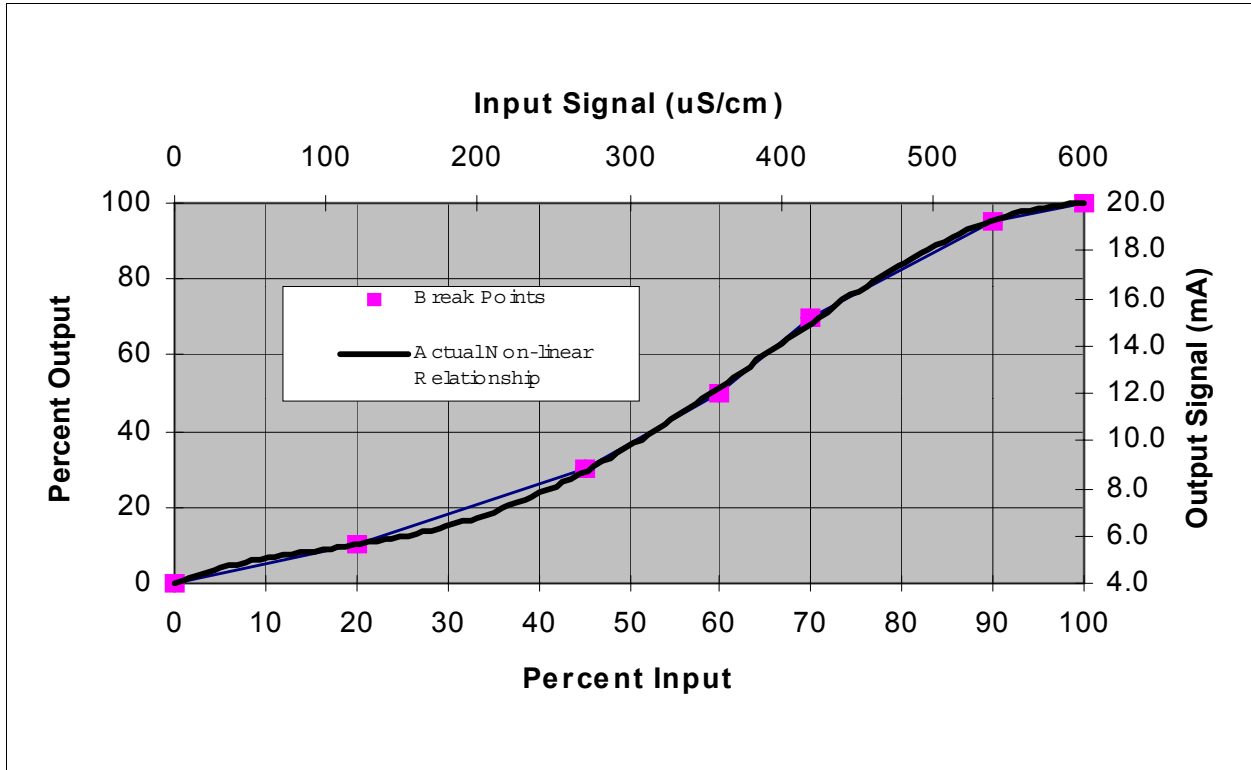

Figure 8-6. Non-linear Output Break Point Determination.

### Analog Output Two State (Basic/Advanced)

The Analog Output Two State sets the output source, span, and range. The output can be sourced to the Primary Process Variable or Temperature. As with Analog Output One, the output span is software selectable for either zero to 20 milliamperes or four to 20 milliamperes. The output function is always linear. Lower and upper range values are defaulted to the full scale process variable range and can be changed to any set of values conforming to Table 3-1, Specifications.

Set the Analog Output Two State using Figure 8-7 as a reference and the following procedure:

- 1) Select the A02.OUT State in the Configure Mode of Operation using the SELECT Key.
- 2) Set the output source using the NEXT Key to toggle between PV and TEMP, and press the ENTER Key to enter the desired source.
- 3) Set the output span using the NEXT Key to toggle between 4-20MA and 0-20MA, and press the ENTER Key to enter the new span.

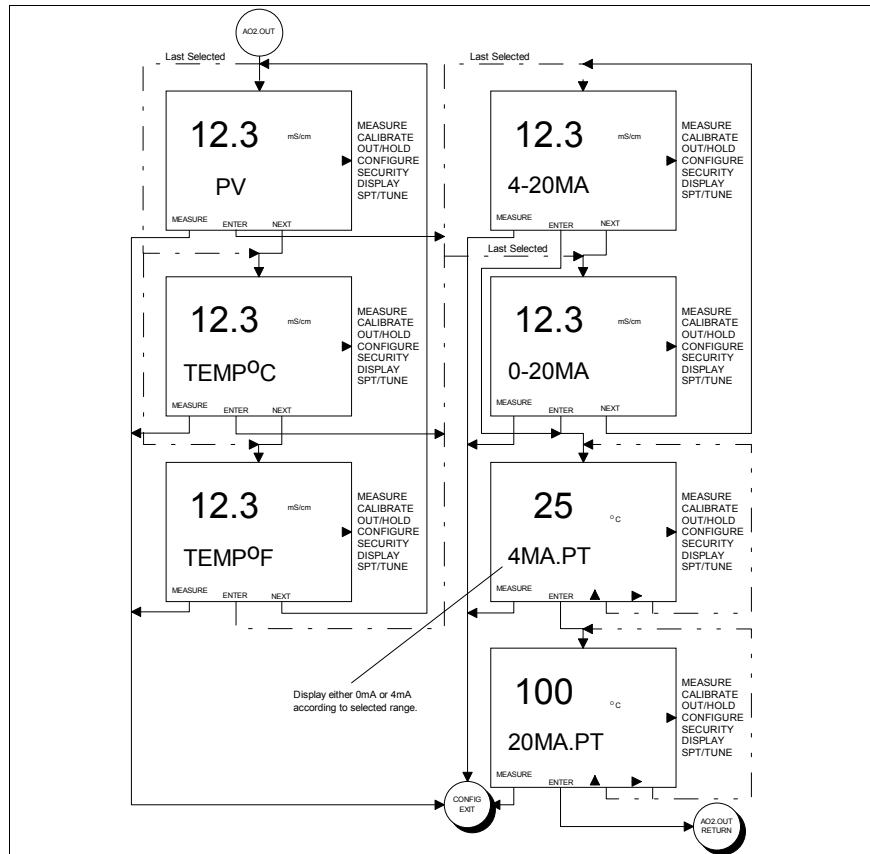

Figure 8-7. Screen Flow Diagram For Analog Output Two Configure State of Operation.

- 4) Set the process variable value for the 0 or 4 milliamper point using the ▲ Key to increment the blinking digit and the ► Key to move to the next digit, and press the ENTER Key to enter the desired value.

- 
- 5) Set the process variable value for the 20 milliampere point using the ▲ Key to increment the blinking digit and the ► Key to move to the next digit, and press the ENTER Key to enter the desired value.

---

### **Relay Output One (Basic/Advanced)**

The Relay Output One State sets the output function and related parameters for Relay One. The output function is dependent on the programming mode. For Basic configurations, Relay One output functions are limited to Setpoint control of the Process Variable. For Advanced configurations, the output functions are not limited and can be configured as a Setpoint sourced to the Process Variable or Temperature, Cycle Timer, Diagnostic Alert, or Sensor Cleaner.

Set the output function of Relay Output One State using Figure 8-8 as a reference and the following procedure:

- 1) Select the RELAY1 State in the Configure Mode of Operation using the SELECT Key.
- 2) Set the output function using the NEXT Key to toggle between HI.PV and LO.PV for Basic Configurations or HI.PV, LO.PV, HI.TMP.C (i.e., High Temperature in Celsius), LO.TMP.C, HI.TMP.F (i.e., High Temperature in Fahrenheit), LO.TMP.F, DIAGS (i.e., Diagnostics), HI.PV.CT (i.e., High Process Variable Cycle Timer), LO.PV.CT, or CLNR (i.e., Cleaner), and press the ENTER Key to enter the new output function.

Since the parameters for each type of relay function are the same, this information will be given after reviewing the applicable functions for each relay output.

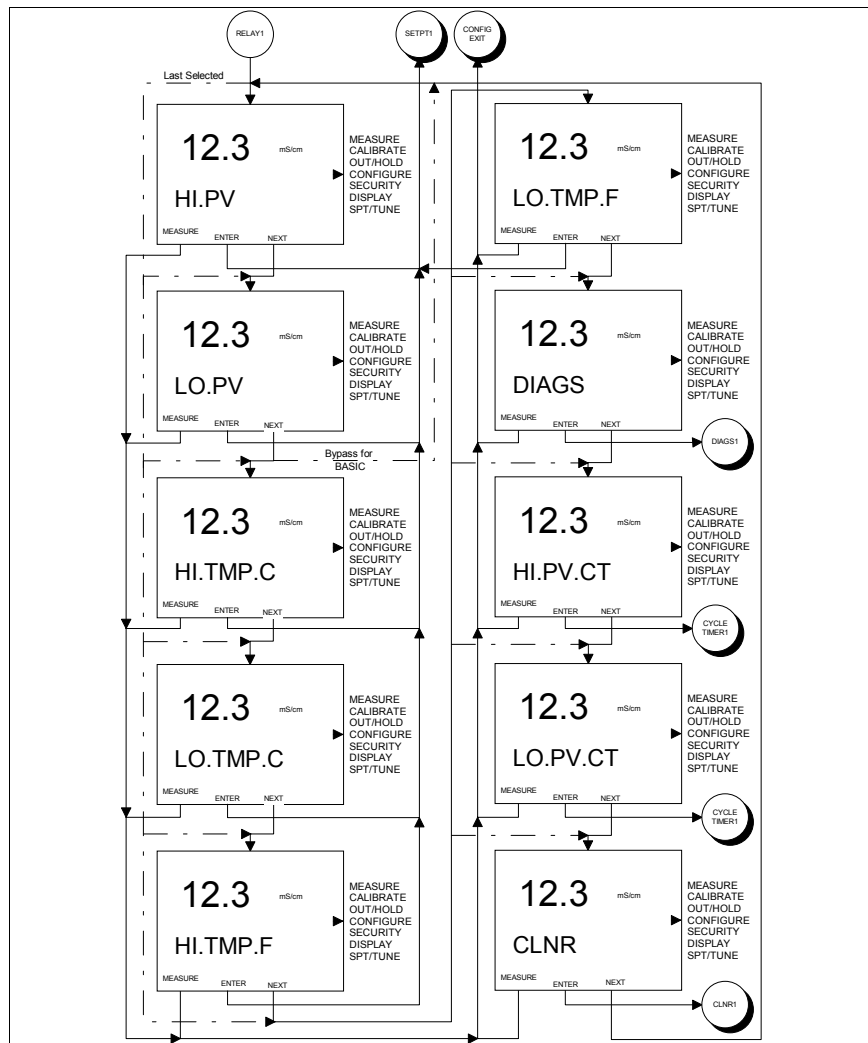

Figure 8-8. Screen Flow Diagram For Relay Output One Configure State of Operation.

### Relay Output Two (Basic/Advanced)

The Relay Output Two State sets the output function and related parameters for Relay Output Two. The output function is dependent on the programming mode. For Basic configurations, Relay Two output functions are limited to Setpoint control of the Process Variable or Temperature. For Advanced configurations, the output functions are not limited and can be configured as a Setpoint sourced to the Process Variable or Temperature, Cycle Timer, Diagnostic Alert, or Sensor Cleaner.

Set the output function of Relay Output Two State using Figure 8-9 as a reference and the following procedure:

- 1) Select the RELAY2 State in the Configure Mode of Operation using the SELECT Key.
- 2) Set the output function using the NEXT Key to toggle between HI.PV, LO.PV, HI.TMP.C, LO.TMP.C, HI.TMP.F, and LO.TMP.F for Basic Configurations or HI.PV, LO.PV, HI.TMP.C, LO.TMP.C, HI.TMP.F, LO.TMP.F, DIAGS, HI.PV.CT, LO.PV.CT, or CLNR, and press the ENTER Key to enter the new function.

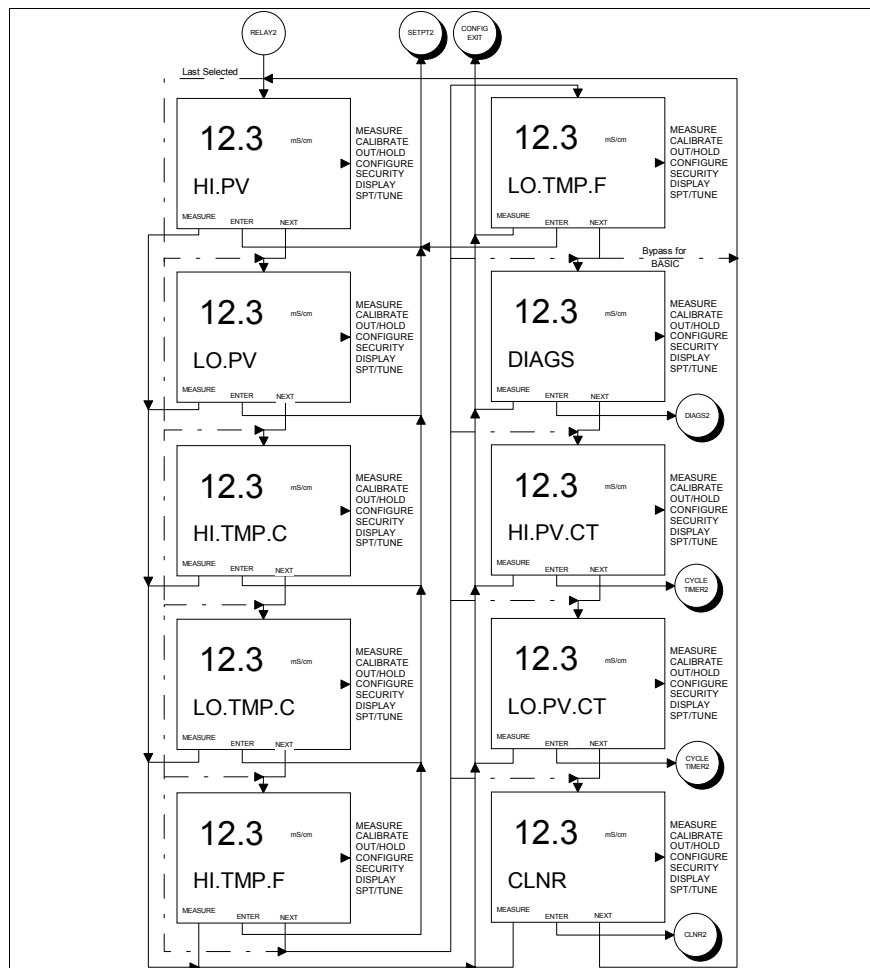

Figure 8-9. Screen Flow Diagram For Relay Output Two Configure State of Operation.

---

Since the parameters for each type of relay function are the same, this information will be given after reviewing the applicable functions for each relay output.

---

### **Relay Output Three (Basic/Advanced)**

The Relay Output Three State sets the output function and parameters for Relay Output Three. The output function is dependent on the programming mode. For Basic configurations, Relay Three output functions are limited to Setpoint control of the Process Variable or Temperature or to a Diagnostic Alert. For Advanced configurations, the output functions are not limited and can be configured as a Setpoint sourced to the Process Variable or Temperature, Cycle Timer, Diagnostic Alert, or Sensor Cleaner.

Set the output function of Relay Output Three State using Figure 8-10 as reference and the following procedure:

- 1) Select the RELAY3 State in the Configure Mode of Operation using the SELECT Key.
- 2) Set the output function using the NEXT Key to toggle between HI.PV, LO.PV, HI.TMP.C, LO.TMP.C, HI.TMP.F, LO.TMP.F, and DIAGS for Basic Configurations or HI.PV, LO.PV, HI.TMP.C, LO.TMP.C, HI.TMP.F, LO.TMP.F, DIAGS, HI.PV.CT, LO.PV.CT, or CLNR, and press the ENTER Key to enter the new function.

Since the parameters for each type of relay function are the same, this information will be given after reviewing the applicable functions for each relay output.

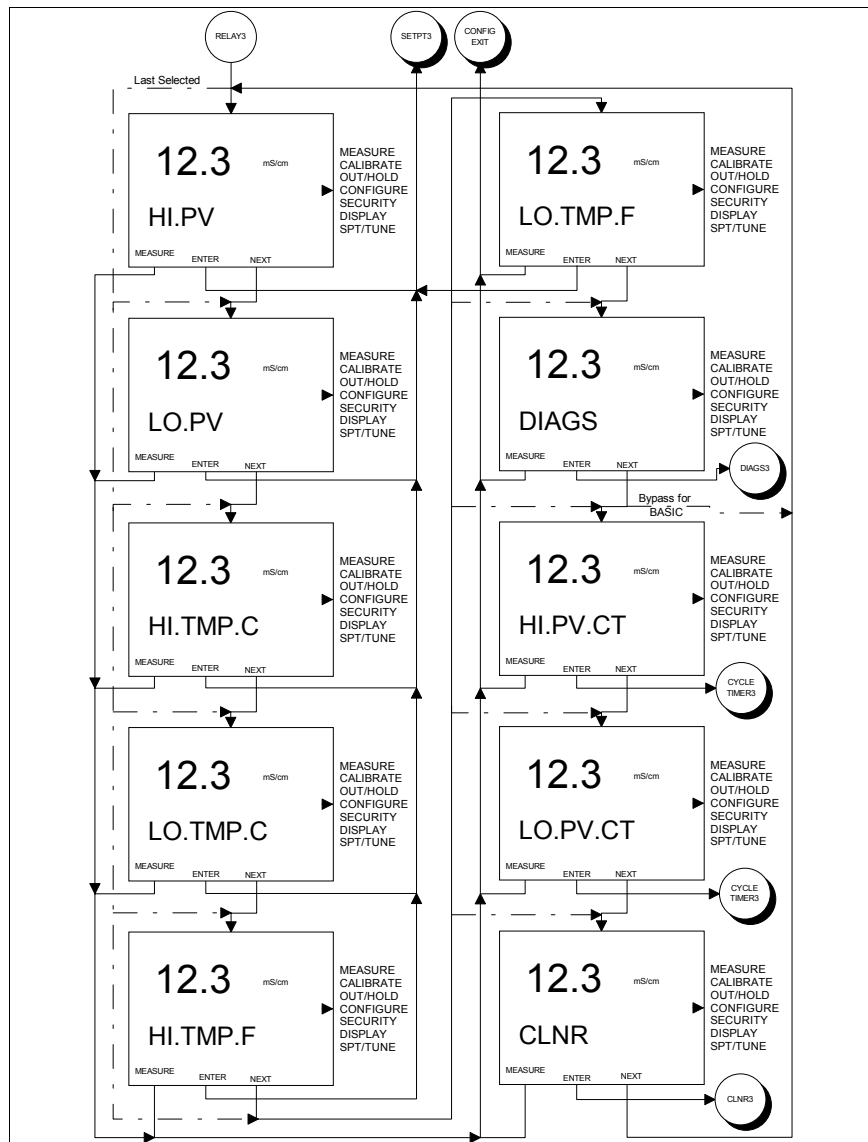

Figure 8-10. Screen Flow Diagram For Relay Output Three Configure State of Operation.

### Setpoint Relay Output (Basic/Advanced)

A Setpoint Relay Output can be configured to energize when the Process Variable or Temperature exceeds or falls below a defined level (i.e., a High or Low Setpoint, respectively). Valid Setpoint values are limited to the Process Variable and/or Temperature ranges defined in Table 1-3, Specifications.

---

To prevent relay chatter, a Setpoint Relay Output has an configurable Deadband. The Deadband control keeps the relay energized until the Process Variable or Temperature has decreased below a High Setpoint value or increased above a Low Setpoint value by the Deadband value. Valid Deadband values are 0.0  $\mu$ S/cm to 2.00 mS/cm for nominal cell constants of 1.00, 0.00 to 200  $\mu$ S/cm for nominal cell constants of 0.1, 0.000 to 20.0  $\mu$ S/cm for nominal cell constants of 0.01, 0 to 10% of the configured Concentration range for Concentration configurations, and 0 to 10°C (18°F) for Temperature sources.

A Time Delay control also refines the function of a Setpoint Relay. Entering a Time Delay value greater than 0.0 minutes enables a waiting period before energizing the relay once the setpoint condition has been met. Valid Time Delay values are 0.0 to 99.9 minutes.

Set the Setpoint parameters of a Relay Output using Figure 8-11 as a reference and the following procedure:

- 1) Set the Setpoint activation condition (i.e., HI SPT or LO SPT) using the ▲ Key to increment the blinking digit and the ► Key to move to the next digit, and press the ENTER Key to enter the new value.
- 2) Set the Deadband (i.e., DBAND) using the ▲ Key to increment the blinking digit and the ► Key to move to the next digit and, press the ENTER Key to enter the new value.
- 3) Set the Time Delay in minutes (i.e., DLY.MIN) using the ▲ Key to increment the blinking digit and the ► Key to move to the next digit, and press the ENTER Key to enter the new value.

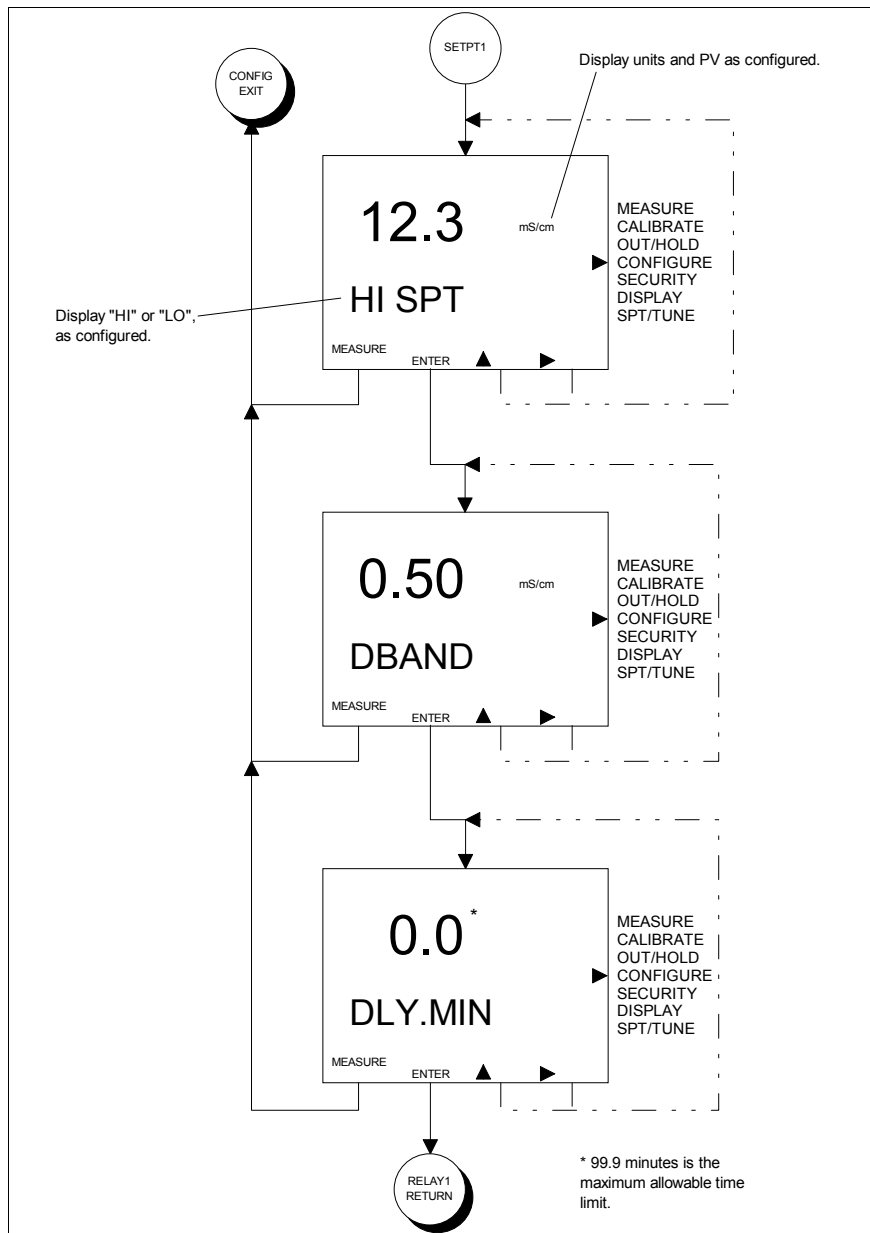

Figure 8-11. Screen Flow Diagram For Setting the Setpoint Relay Output Configure State of Operation.

### Diagnostic Relay Output (Basic/Advanced)

A Diagnostic Relay Output simply energizes when a diagnostic condition has been detected. The relay can be configured to trigger on a sensor, instrument, or all diagnostic conditions.

---

Set the trigger for the Diagnostic Relay Output using Figure 8-12 as a reference and the following procedure:

- 1) Set the Diagnostic trigger using the NEXT Key to toggle between ALL, SENSOR, and INSTR. (i.e., Instrument), and press the ENTER Key to enter the new trigger.

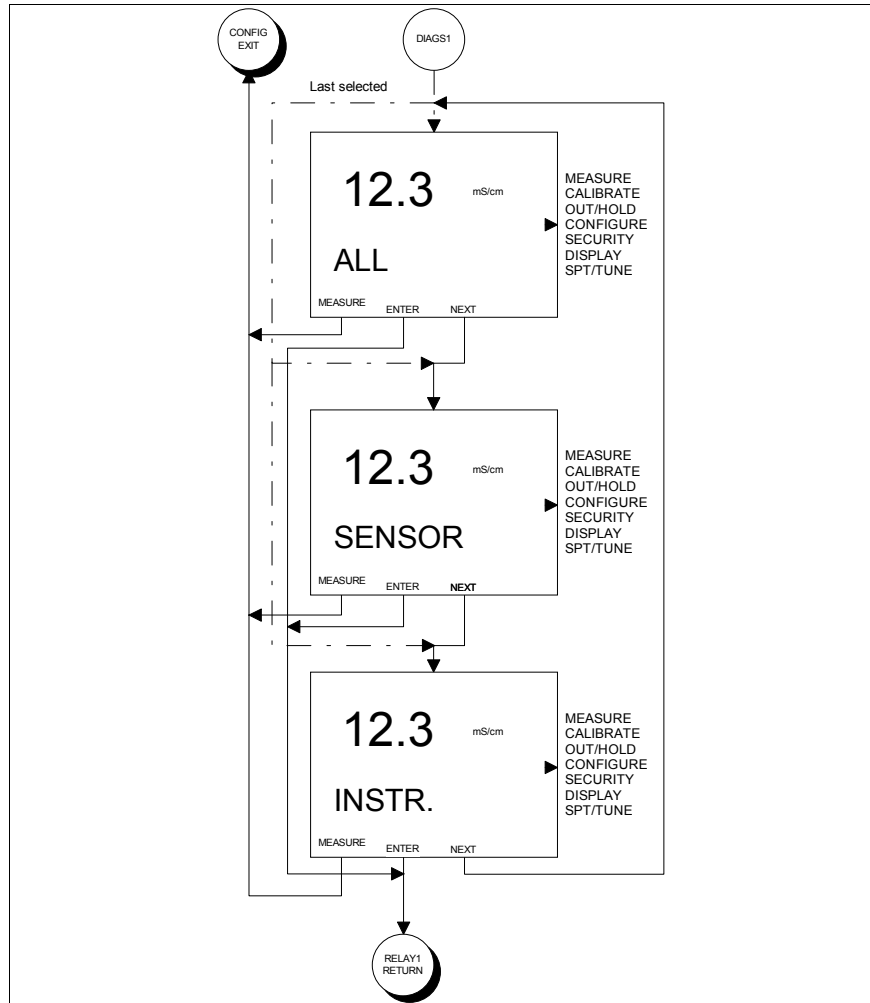

Figure 8-12. Screen Flow Diagram For Setting the Diagnostic Relay Output Configure State of Operation.

---

### Cycle Timer Relay Output (Advanced)

A Cycle Timer can only be sourced to the Process Variable and can energize the relay for either a High or Low setpoint condition.

As with a Setpoint Relay Output, the Setpoint condition functions in the same manner. The Deadband control is replaced with the Cycle Time (CYC.MIN). A Cycle Timer energizes the Relay Output for a set amount of time (ON.TIME) and de-energizes for the remainder of the cycle (CYC.MIN). This cycle repeats until the Setpoint condition is no longer met. For more information on the Cycle Timer, see Section 2, Overview.

Valid Setpoint values are limited to the Process Variable range defined in Table 1-3, Specifications. Valid Cycle Time and On Time values are 0.0 to 99.9 minutes.

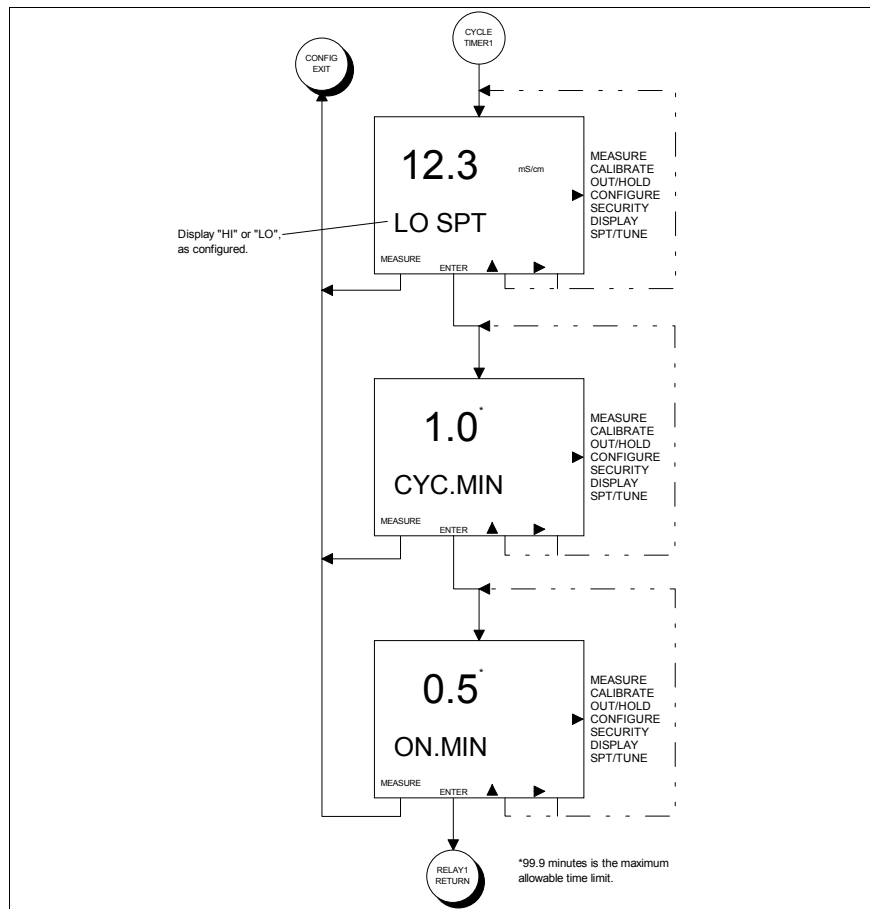

Figure 8-13. Screen Flow Diagram For Setting the Cycle Timer Relay Output Configure State of Operation.

---

Set the Cycle Timer parameters of a Relay Output using Figure 8-13 as a reference and the following procedure:

- 1) Set the Setpoint activation condition (i.e., LO SPT or HI SPT) using the ▲ Key to increment the blinking digit and the ► Key to move to the next digit, and press the ENTER Key to enter the new value.
- 2) Set the Cycle Time in minutes (i.e., CYC.MIN) using the ▲ Key to increment the blinking digit and the ► Key to move to the next digit, and press the ENTER Key to enter the new value.
- 3) Set the On Time in minutes (i.e., ON.MIN) using the ▲ Key to increment the blinking digit and the ► Key to move to the next digit, and press the ENTER Key to enter the new value.

---

### **Cleaner Relay Output (Advanced)**

Automatic sensor cleaning can be accomplished using any one of the three relay outputs. At a prescribed time interval, a Cleaner Relay Output will energize and allow the activation of a cleaning device. While in the energized state, analog and relay outputs can be held to values captured just prior to the cleaning cycle (i.e., energized state). If a relay hold condition is not desirable, non-cleaner relay outputs can be disable during a cleaning cycle.

To specify a cleaning cycle, the Cycle, On, and Recovery Times must be defined. The Cycle Time defines the repeating period between cleaning cycles, the On Time defines the length of time the relay will be energized, and the Recovery Time defines the length of time after the relay has been de-energized before the hold and/or disable condition(s) will be removed. Valid times for Cycle Time are 0.0 to 99.9 hours and for On and Recovery Times are 0.0 to 99.9 minutes.

---

Set the Cleaner parameters of a Relay Output using Figure 8-14 as a reference and the following procedure:

- 1) Set the Cycle Time in hours (i.e., CYC.HRS) using the ▲ Key to increment the blinking digit and the ► Key to move to the next digit, and press the ENTER Key to enter the new value.
- 2) Set the On Time in minutes (i.e., ON.MIN) using the ▲ Key to increment the blinking digit and the ► Key to move to the next digit, and press the ENTER Key to enter the new value.
- 3) Set the Recovery Time in minutes (i.e., RCV.MIN) using the ▲ Key to increment the blinking digit and the ► Key to move to the next digit, and press the ENTER Key to enter the new value.
- 4) Hold the Analog Outputs (i.e., AO.HLD) during the On and Recovery Times using the YES Key, or leave the Analog Outputs live during the On and Recovery Times using the No Key.
- 5) Hold the Relay Outputs (i.e., RO.HLD) during the On and Recovery Times using the YES Key, or continue onto the Disable Relay Outputs State using the No Key.
- 6) Disable the Relay Outputs (i.e., DSBL.RO) during the On and Recovery Times using the YES Key, or leave the Relay Outputs live during the On and Recovery Times using the No Key.

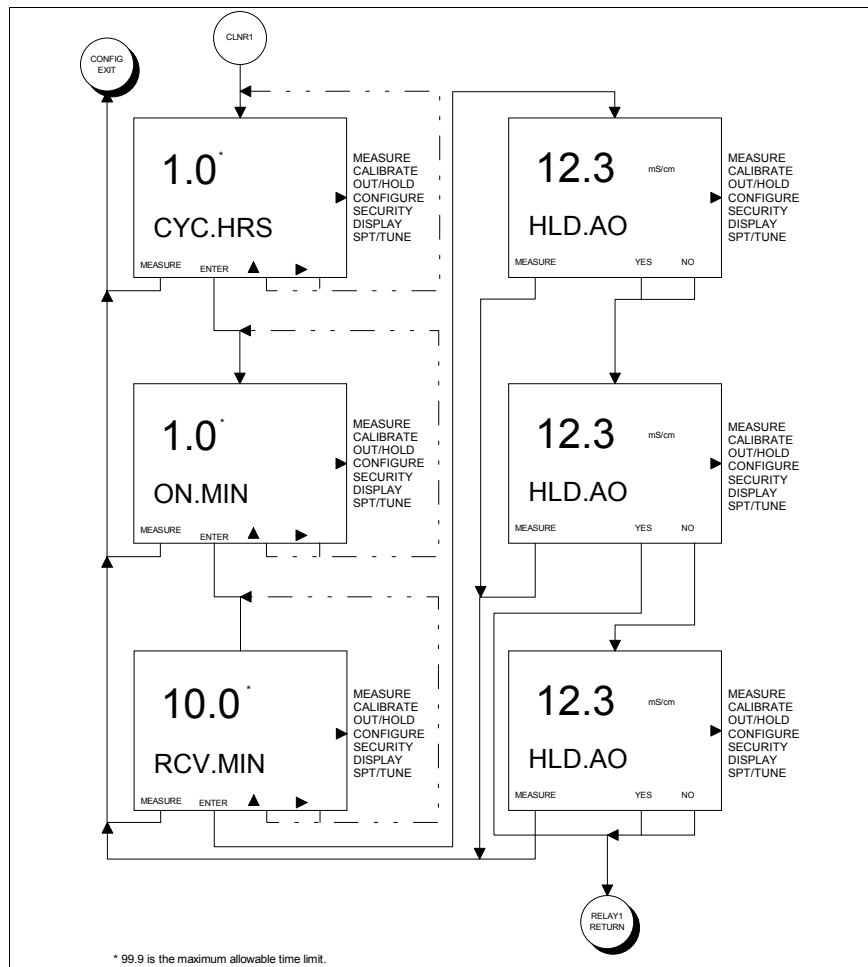

Figure 8-14. Screen Flow Diagram For Setting the Cleaner Relay Output Configure State of Operation.

### Damping State (Basic/Advanced)

The Damping State applies a lag function on the configured signals and reduces fluctuations caused by erratic process conditions. The damping value can be set from 0.0 to 99.9 seconds and represents the time required to reach 63.2% of a step change in the process variable.

For the Basic Programming Mode, the damping value can only be applied to the process variable input signal. The Advanced Programming Mode allows for separate damping of the Displayed Process Variable, Analog Output One, and Analog Output Two.

Set the Damping State using Figure 8-15 as a reference and the following procedure:

- 1) Select the DAMPNG State in the Configure Mode of Operation using the SELECT Key.
- 2a) For Basic configurations, set the new damping value using the ▲ Key to increment the blinking digit and the ► Key to move to the next digit, and press the ENTER Key to enter the new value.
- 2b) For Advanced configurations, set the new damping value for the Displayed Process Variable (i.e., DSP.SEC) using the ▲ Key to increment the blinking digit and the ► Key to move to the next digit, and press the ENTER Key to enter the new value.

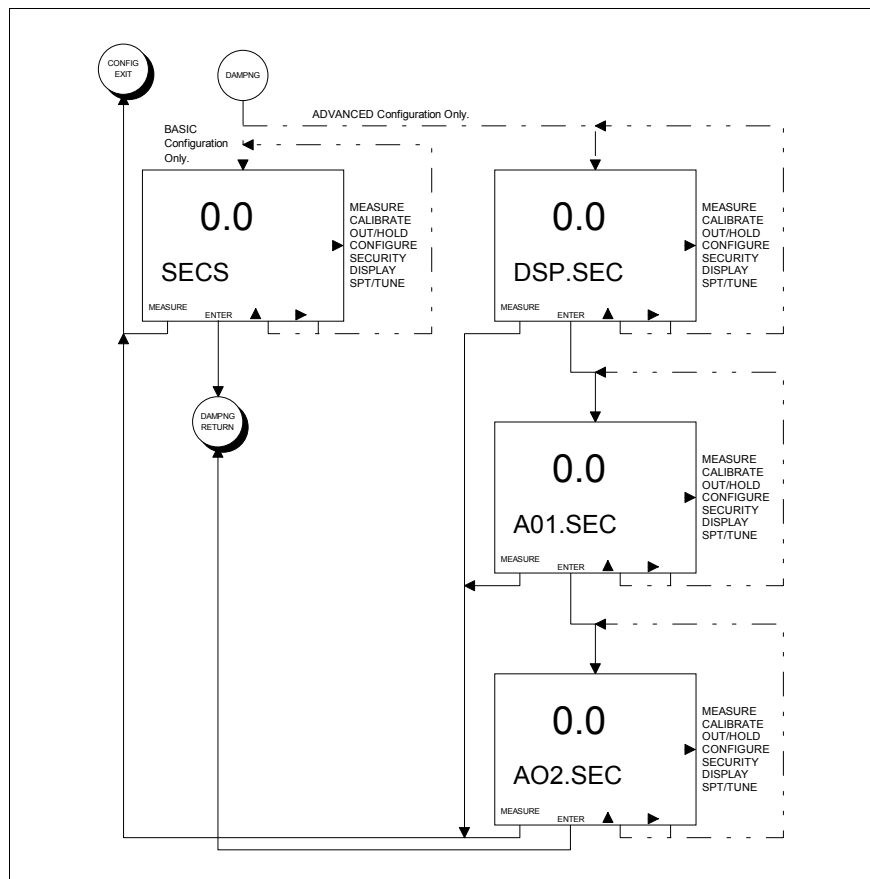

Figure 8-15. Screen Flow Diagram For Damping Configure State of Operation.

- 
- 3) For Advanced configurations, set the damping value for Analog Output One (i.e., AO1.SEC) using the ▲ Key to increment the blinking digit and the ► Key to move to the next digit, and press the ENTER Key to enter the new value.
  - 4) For Advanced configurations, set the damping value for Analog Output Two (i.e., AO2.SEC) using the ▲ Key to increment the blinking digit and the ► Key to move to the next digit, and press the ENTER Key to enter the new value.

---

### **Diagnostics State (Basic/Advanced)**

The Diagnostics State allows the built-in sensor diagnostics to be disabled.

Set the DIAG (i.e., Diagnostics) State using the following procedure:

- 1) Select the DIAG State using the SELECT Key.
- 2) Toggle the diagnostics function to the desired state (i.e., OFF or ON) using the ▲ Key, and press the ENTER Key to enter the new value.

---

### **Safe Mode One State (Basic/Advanced)**

The Safe Mode One State determines the Analog Output One level if an error condition occurs that renders the analyzer inoperable. The available states are FAIL.LO (i.e., fail low) or FAIL.HI (i.e., fail high). For more information on error conditions, see Section 13, Diagnostics.

Set the Safe Mode One State using the following procedure:

- 1) Select the SAF.MD.1 State in the Configure Mode of Operation using the SELECT Key.

- 
- 2) Set the safe mode by using the NEXT Key to toggle between FAIL.LO and FAIL.HI, and use the ENTER Key to enter the new value.

---

### **Safe Mode Two State (Basic/Advanced)**

The Safe Mode Two State determines the Analog Output Two level if an error condition occurs that renders the analyzer inoperable. The available states are FAIL.LO (i.e., fail low) and FAIL.HI (i.e., fail high). For more information on error conditions, see Section 13, Diagnostics.

Set the Safe Mode Two State using the following procedure:

- 1) Select the SAF.MD.2 State in the Configure Mode of Operation using the SELECT Key.
- 2) Set the safe mode by using the NEXT Key to toggle between FAIL.LO and FAIL.HI, and use the ENTER Key to enter the new value.

---

### **Spike State (Advanced)**

The Spike State sets the diagnostic spike level as a percent of output. This level will determine the magnitude of the spike imposed on Analog Output One.

When the Spike has been set for any level greater than 0% and is enabled in the Spike Output State, the TB84TE Series analyzer will modulate the Analog Output One signal by the configured level for one second out of every six seconds when a problem condition is detected. Using this modulation, the analyzer informs the operator of a detected diagnostic condition. For more information on problem conditions, see Section 13, Diagnostics. For a description of the diagnostic spike feature, see Section 2, Analyzer Functionality And Operator Interface Controls.

---

Set the Spike State using the following procedure:

- 1) Select the SPIKE State in the Configure Mode of Operation using the SELECT Key.
- 2) Set the SPK.MAG (i.e., spike magnitude) using the ▲ Key to increment the blinking digit and the ► Key to move to the next digit, and press the ENTER Key to enter the new value. The Spike Magnitude is entered as a percentage of the 16 milliamper output range for a four to 20 milliamper output or 20 milliamper output range for a zero to 20 milliamper output (e.g., 10% will generate a 1.6 milliamper spike for a four to 20 milliamper output range).

**Note: Once the Spike State is OFF in the Output/Hold Mode of Operation, changing the configured spike level in the Configure Mode will not reenale the Spike State. The Spike State can only be turned ON or OFF in the Output/Hold Mode of Operation.**

---

## CONFIGURATION LOCKOUT

The TB84TE Series analyzer has a lockout feature that, once engaged, prohibits access to the Configure Mode. This feature does not affect parameters that can be changed in the other modes of operation including Calibrate, Output/Hold, Security, secondary Display, and Setpoint/Tune.

To enable the lockout feature, change jumper W1 on the Microprocessor/Display PCB from pins 1 and 2 (i.e., position A - the factory default position) to pins 2 and 3 (i.e., position B). Use Figure 8-16 and Section 16, Replacement Procedures, for jumper positions and circuit board handling procedures.

FRONT BEZEL ASSEMBLY W/  
MICROPROCESSOR/DISPLAY PCB ASSEMBLY

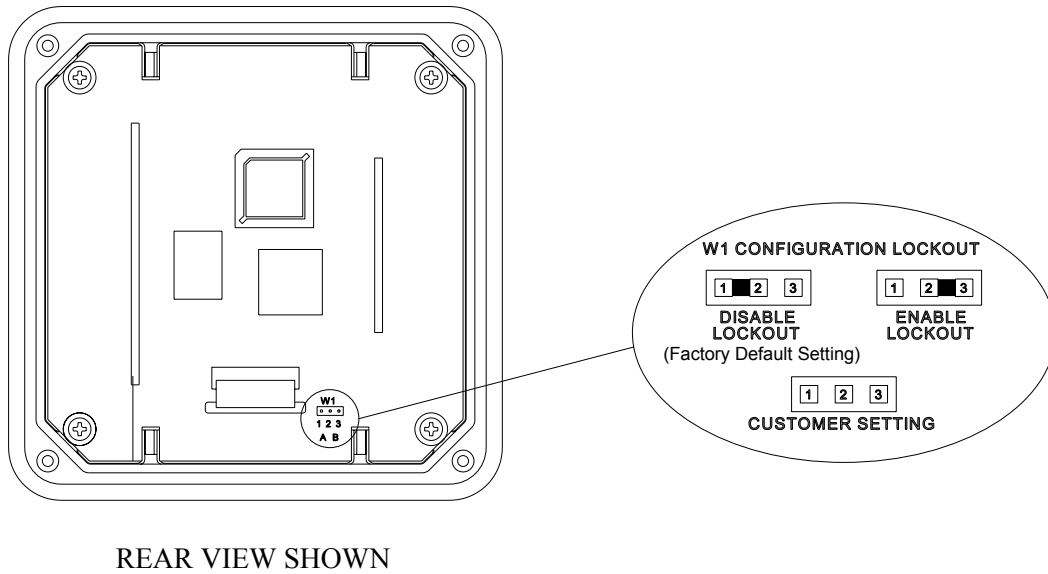

Figure 8-16. Configuration Lockout Jumper Location On Microprocessor/Display PCB Assembly.

---

## SECTION 9 - SECURITY MODE

---

### INTRODUCTION

The Security Mode of Operation establishes password protection against unauthorized changes to analyzer functions by unqualified personnel. Password protection can be assigned to the Calibrate, Output/Hold, Configure, Setpoint/Tune Modes of Operation.

---

### SECURITY STATE OF OPERATION

The Security Mode of Operation provides password protection for critical operating environments. Each mode or state of operation that can be password protected is set by toggling the primary display between security OFF and ON using the ▲ Smart Key. As seen in Figure 9-1, all security assignments must be made before a password can be defined.

When one or more mode(s)/state has the security ON, the Security State will also be secured. One password assignment applies to all secured modes and states.

Set the Security State using Figure 9-1 as a reference and the following procedure:

- 1) Select the SECUR (i.e., Security) Mode of Operation using the SELECT Key.
- 2) Set the security for the CALIBR (i.e., Calibrate) Mode using the ▲ Key to toggle between ON and OFF, and press the ENTER Key to enter the new value.
- 3) Set the security for the OUTPUT (i.e., Output/Hold) Mode using the ▲ Key to toggle between ON and OFF, and press the ENTER Key to enter the new value.
- 4) Set the security for the CONFIG (i.e., Modify Configure) State using the ▲ Key to toggle between ON and OFF, and press the ENTER Key to enter the new value.

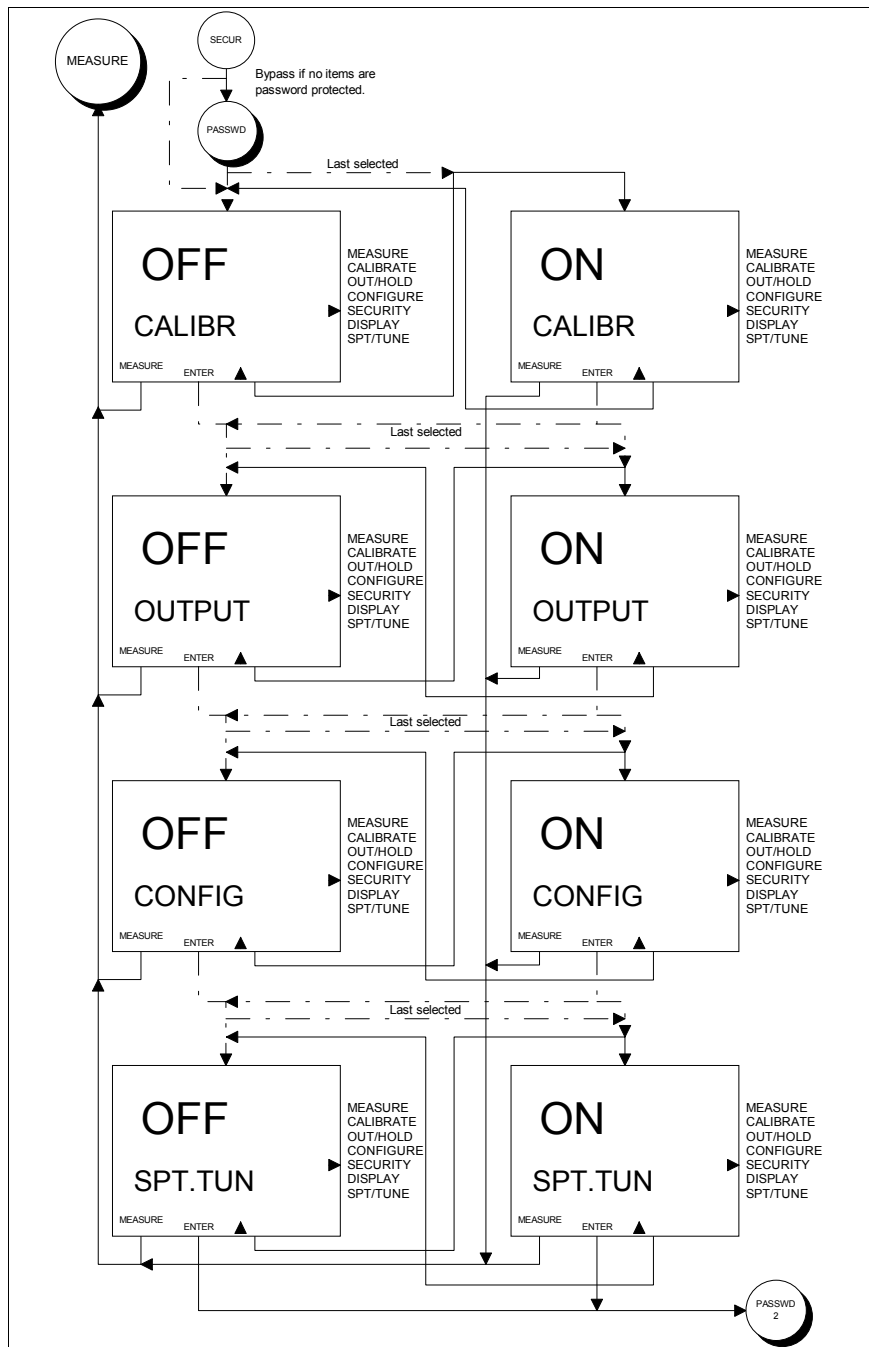

Figure 9-1. Screen Flow Diagram For Security State of Operation.

- 5) Set the security for the SPT.TUN (i.e., Setpoint/Tune) Mode using the ▲ Key to toggle between ON and OFF, and press the ENTER Key to enter the new value.

- 
- 6) Define the password for all secured modes and states using the ▲ Key to increment the blinking digit and the ► Key to move to the next digit, and press the ENTER Key to enter the password.

**Note: The password must be defined as three digits and verified to enable security on the modes/states entered in steps 2 through 4. If security is OFF for all modes/states, the password state will be bypassed.**

- 6) Verify the password using the ▲ Key to increment the blinking digit and the ► Key to move to the next digit, and press the ENTER Key to enter the password.

Remove all security using the following procedure:

- 1) Select the SECUR Mode of Operation using the SELECT Key.
- 2) Enter the password for all secured modes and states using the ▲ Key to increment the blinking digit and the ► Key to move to the next digit, and press the ENTER Key to submit the password.
- 3) Set the security for the CALIBR (i.e., Calibrate) Mode by pressing the ▲ Key to toggle the display to OFF, and press the ENTER Key to enter the value.
- 4) Set the security for the OUTPUT (i.e., Output/Hold) Mode by pressing the ▲ Key to toggle the display to OFF, and press the ENTER Key to enter the value.
- 5) Set the security for the CONFIG (i.e., Modify Configure) State by pressing the ▲ Key to toggle the display to OFF, and press the ENTER Key to enter the value.
- 6) Set the security for the SPT.TUN (i.e., Setpoint/Tune) Mode by pressing the ▲ Key to toggle the display to OFF, and press the ENTER Key to enter the value.

---

Change the password or security state using the following procedure:

- 1) Select the SECUR Mode of Operation using the SELECT Key.
- 2) Enter the password for all secured modes and states using the ▲ Key to increment the blinking digit and the ► Key to move to the next digit, and press the ENTER Key to submit the password.
- 3) Leave the security state unchanged for CALIBR (i.e., Calibrate) Mode by using the ENTER Key, or if needed, change the security state for CALIBR (i.e., Calibrate) using the ▲ Key. Press the ENTER Key to enter the new value.
- 4) Leave the security state unchanged for OUTPUT (i.e., Output/Hold) Mode by using the ENTER Key, or if needed, change the security state for OUTPUT using the ▲ Key. Press the ENTER Key to enter the new value.
- 5) Leave the security state unchanged for CONFIG (i.e., Modify Configure) State by using the ENTER Key, or if needed, change the security state for CONFIG (i.e., Modify Configure) using the ▲ Key. Press the ENTER Key to enter the new value.
- 6) Leave the security state unchanged for SPT.TUN (i.e., Setpoint/Tune) Mode by using the ENTER Key, or if needed, change the security state for SPT.TUN (i.e., Setpoint/Tune) using the ▲ Key. Press the ENTER Key to enter the new value.
- 7) Change the password for all secured modes and states using the ▲ Key to increment the blinking digit and the ► Key to move to the next digit, and press the ENTER Key to enter the password.

- 
- 8) Verify the new password using the ▲ Key to increment the blinking digit and the ► Key to move to the next digit, and press the ENTER Key to enter the password.

**Note: If the password was not changed, the verification of the old password will not be required.**

If the password is lost, the security can be removed using the Reset Password State of Operation. To reset the password, see Section 12, Utility Mode.



---

## SECTION 10 - SECONDARY DISPLAY MODE

---

### INTRODUCTION

The TB84TE Series analyzer has two display regions. In the Measure Mode of Operation, the primary display region shows the measured process variable, and the secondary display region can show a multitude of process, sensor, or analyzer information. This secondary information can be viewed or set as the displayed value when in the Measure Mode of Operation.

---

### SECONDARY DISPLAY STATE OF OPERATION

The Secondary Display Mode of Operation can contain as many as eight states of operation that provide information on the process temperature, analyzer settings, and analyzer status. As seen in Figure 10-1, each Secondary Display State can be sequentially viewed by using the NEXT Smart Key. To have any given Secondary Display State be continually shown in the Measure Mode, press the ENTER Smart Key while the desired state is displayed. The TB84TE Series analyzer will proceed to the Measure Mode and display the entered Secondary Display State in the secondary display region.



---

## SECTION 11 - SETPOINT/TUNE MODE

---

### INTRODUCTION

The Setpoint/Tune Mode of Operation provides a direct method to tune relay output parameters. Though this mode of operation can not be used to change the function a relay, it does provide the ability to quickly change relay parameters pertinent to process control. To change the relay output function, see Section 8, Configure Mode.

---

### SETPOINT/TUNE STATES OF OPERATION

The Setpoint/Tune Mode consists of three states of operation: RELAY1, RELAY2, and RELAY3. Each state provides the ability to update operational parameters for the configured relay functions. For instance if Relay Output One is configured to function as a High Process Variable Setpoint, the Setpoint, Deadband, and Time Delay will be tunable parameters available in the Setpoint/Tune Relay One State of Operation.

Since the tunable parameters are dependent on the configured relay function, the following sections will only describe the adjustment of these parameters.

---

#### Setpoint Relay Output (Basic/Advanced)

A Setpoint Relay Output can be configured to energize when the Process Variable or Temperature exceeds or falls below a defined level (i.e., a High or Low Setpoint). Valid Setpoint values are limited to the Process Variable and/or Temperature ranges defined in Table 1-3, Specifications.

To prevent relay chatter, a Setpoint Relay Output has an configurable Deadband. The Deadband control keeps the relay energized until the Process Variable or Temperature has decreased below a High Setpoint value or increased above a Low Setpoint value by the Deadband value. Valid Deadband values are 0.0  $\mu$ S/cm to 2.00 mS/cm for nominal cell constants

---

of 1.00, 0.00 to 200  $\mu\text{S}/\text{cm}$  for nominal cell constants of 0.1, 0.000 to 20.0  $\mu\text{S}/\text{cm}$  for nominal cell constants of 0.01, 0 to 10% of the configured Concentration range for Concentration configurations, and 0 to 10°C (18°F) for Temperature sources.

A Time Delay control also refines the function of a Setpoint Relay. Entering a Time Delay value greater than 0.0 minutes enables a waiting period before energizing the relay once the setpoint condition has been met. Valid Time Delay values are 0.0 to 99.9 minutes.

Set the Setpoint parameters of a Relay Output using Figure 11-1 as a reference and the following procedure:

- 1) Set the Setpoint activation condition (i.e., LO SPT or HI SPT) using the ▲ Key to increment the blinking digit and the ► Key to move to the next digit, and press the ENTER Key to enter the new value.
- 2) Set the Deadband (i.e., DBAND) using the ▲ Key to increment the blinking digit and the ► Key to move to the next digit and, press the ENTER Key to enter the new value.
- 3) Set the Time Delay in minutes (i.e., DLY.MIN) using the ▲ Key to increment the blinking digit and the ► Key to move to the next digit, and press the ENTER Key to enter the new value.

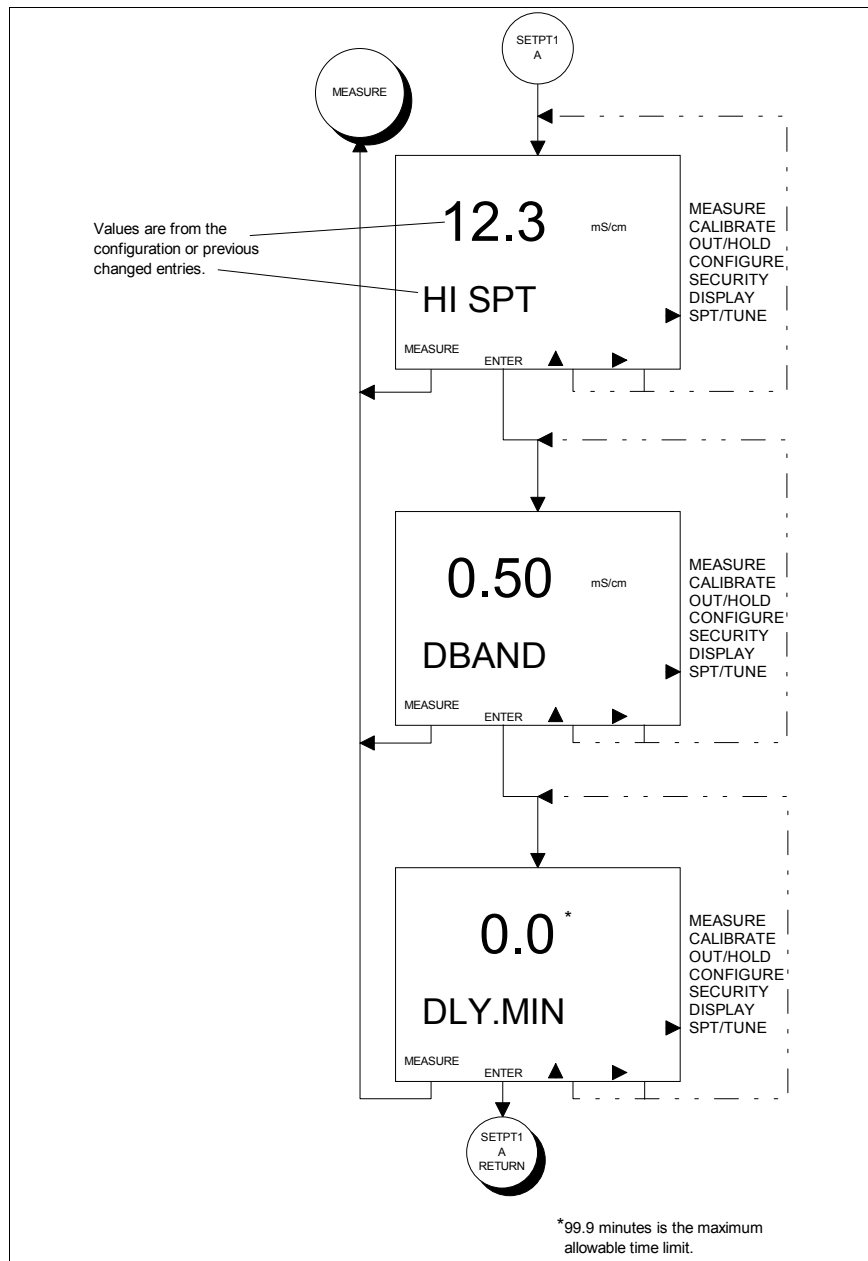

Figure 11-1. Screen Flow Diagram For Setting the Setpoint Relay Output Setpoint/Tune State of Operation.

### Diagnostic Relay Output (Basic/Advanced)

A Diagnostic Relay Output simply energizes when a diagnostic condition has been detected. The relay can be configured to trigger on a sensor, instrument, or all diagnostic conditions.

---

Set the trigger for the Diagnostic Relay Output using Figure 11-2 as a reference and the following procedure:

- 1) Set the Diagnostic trigger using the NEXT Key to toggle between ALL, SENSOR, and INSTR. (i.e., Instrument), and press the ENTER Key to enter the new trigger.

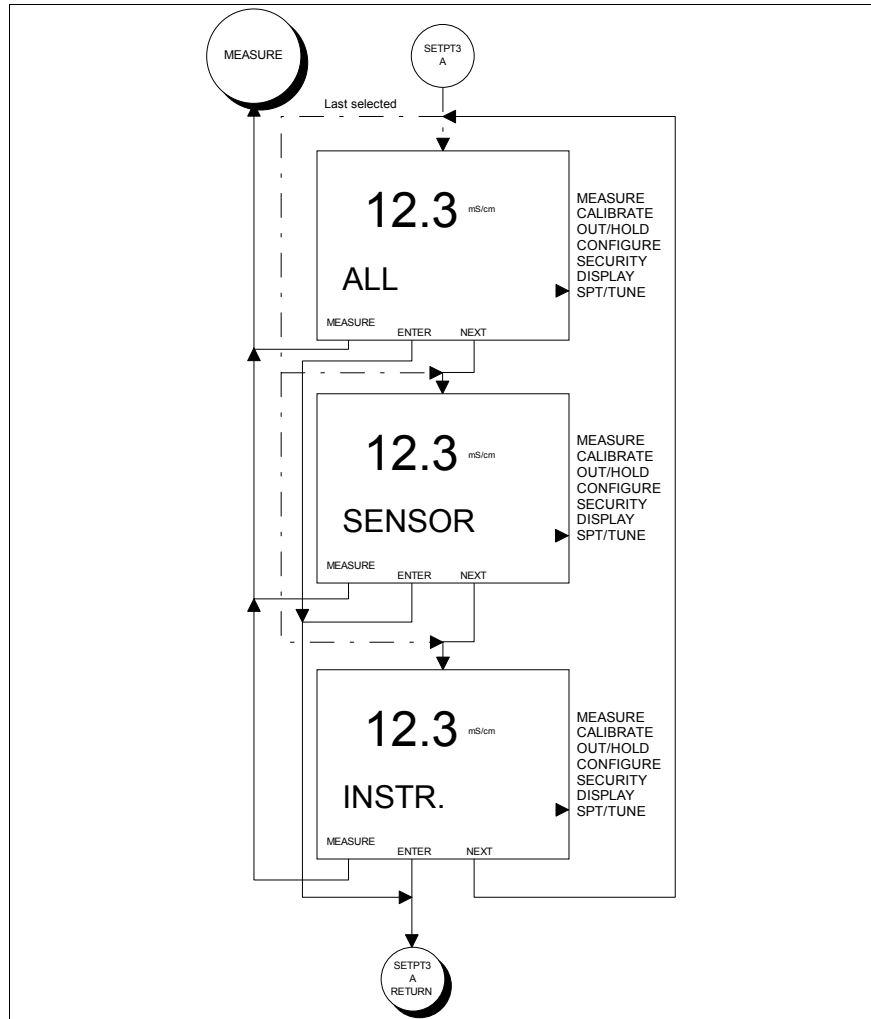

Figure 11-2. Screen Flow Diagram For Setting the Diagnostic Relay Output Setpoint/Tune State of Operation.

---

### Cycle Timer Relay Output (Advanced)

A Cycle Timer can only be sourced to the Process Variable and can energize the relay for either a High or Low setpoint condition.

As with a Setpoint Relay Output, the Setpoint condition functions in the same manner; however, the Deadband control is replaced with the Cycle Time. Thus, a Cycle Timer energizes the Relay Output for a set amount of time (ON.TIME) and de-energizes it for the remainder of the cycle (CYC.MIN). This cycle repeats until the Setpoint condition is no longer met. For more information on the Cycle Timer, see Section 2, Overview.

Valid Setpoint values are limited to the Process Variable range defined in Table 1-3, Specifications. Valid Cycle Time and On Time values are 0.0 to 99.9 minutes.

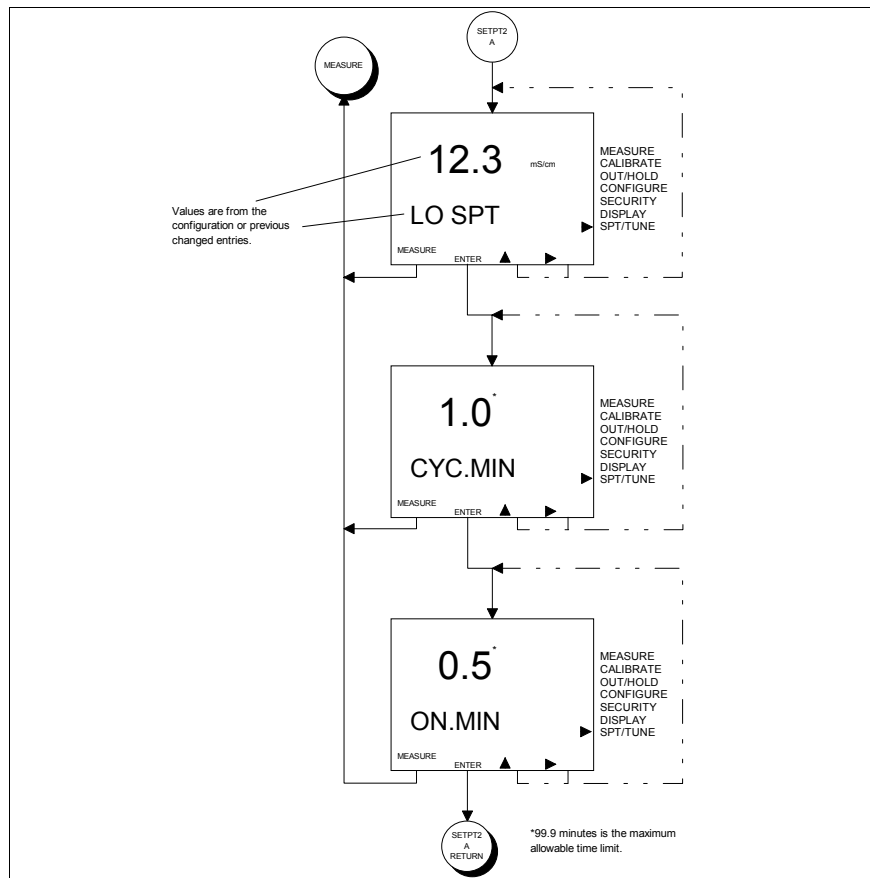

Figure 11-3. Screen Flow Diagram For Setting the Cycle Timer Relay Output Configure State of Operation.

---

Set the Cycle Timer parameters of a Relay Output using Figure 11-3 as a reference and the following procedure:

- 1) Set the Setpoint activation condition (i.e., LO SPT or HI SPT) using the ▲ Key to increment the blinking digit and the ► Key to move to the next digit, and press the ENTER Key to enter the new value.
- 2) Set the Cycle Time in minutes (i.e., CYC.MIN) using the ▲ Key to increment the blinking digit and the ► Key to move to the next digit, and press the ENTER Key to enter the new value.
- 3) Set the On Time in minutes (i.e., ON.MIN) using the ▲ Key to increment the blinking digit and the ► Key to move to the next digit, and press the ENTER Key to enter the new value.

---

### **Cleaner Relay Output (Advanced)**

Automatic sensor cleaning can be accomplished using any one of the three relay outputs. At a prescribed time interval, a Cleaner Relay Output will energize and allow the activation of a cleaning device. While in the energized state, analog and relay outputs can be held to values captured just prior to the cleaning cycle (i.e., energized state). If a relay hold condition is not desirable, non-cleaner relay outputs can be disabled during a cleaning cycle.

To specify a cleaning cycle, the Cycle, On, and Recovery Times must be defined. The Cycle Time defines the repeating period between cleaning cycles, the On Time defines the length of time the relay will be energized, and the Recovery Time defines the length of time after the relay has been de-energized before the hold and/or disable condition(s) will be removed. Valid times for Cycle Time are 0.0 to 99.9 hours and for On and Recovery Times are 0.0 to 99.9 minutes.

---

Set the Cleaner parameters of a Relay Output using Figure 11-4 as a reference and the following procedure:

- 1) Set the Cycle Time in hours (i.e., CYC.HRS) using the ▲ Key to increment the blinking digit and the ► Key to move to the next digit, and press the ENTER Key to enter the new value.
- 2) Set the On Time in minutes (i.e., ON.MIN) using the ▲ Key to increment the blinking digit and the ► Key to move to the next digit, and press the ENTER Key to enter the new value.
- 3) Set the Recovery Time in minutes (i.e., RCV.MIN) using the ▲ Key to increment the blinking digit and the ► Key to move to the next digit, and press the ENTER Key to enter the new value.
- 4) Hold the Analog Outputs (i.e., AO.HLD) during the On and Recovery Times using the YES Key, or leave the Analog Outputs live during the On and Recovery Times using the No Key.
- 5) Hold the Relay Outputs (i.e., RO.HLD) during the On and Recovery Times using the YES Key, or continue onto the Disable Relay Outputs State using the No Key.
- 6) Disable the Relay Outputs (i.e., DSBL.RO) during the On and Recovery Times using the YES Key, or leave the Relay Outputs live during the On and Recovery Times using the No Key.

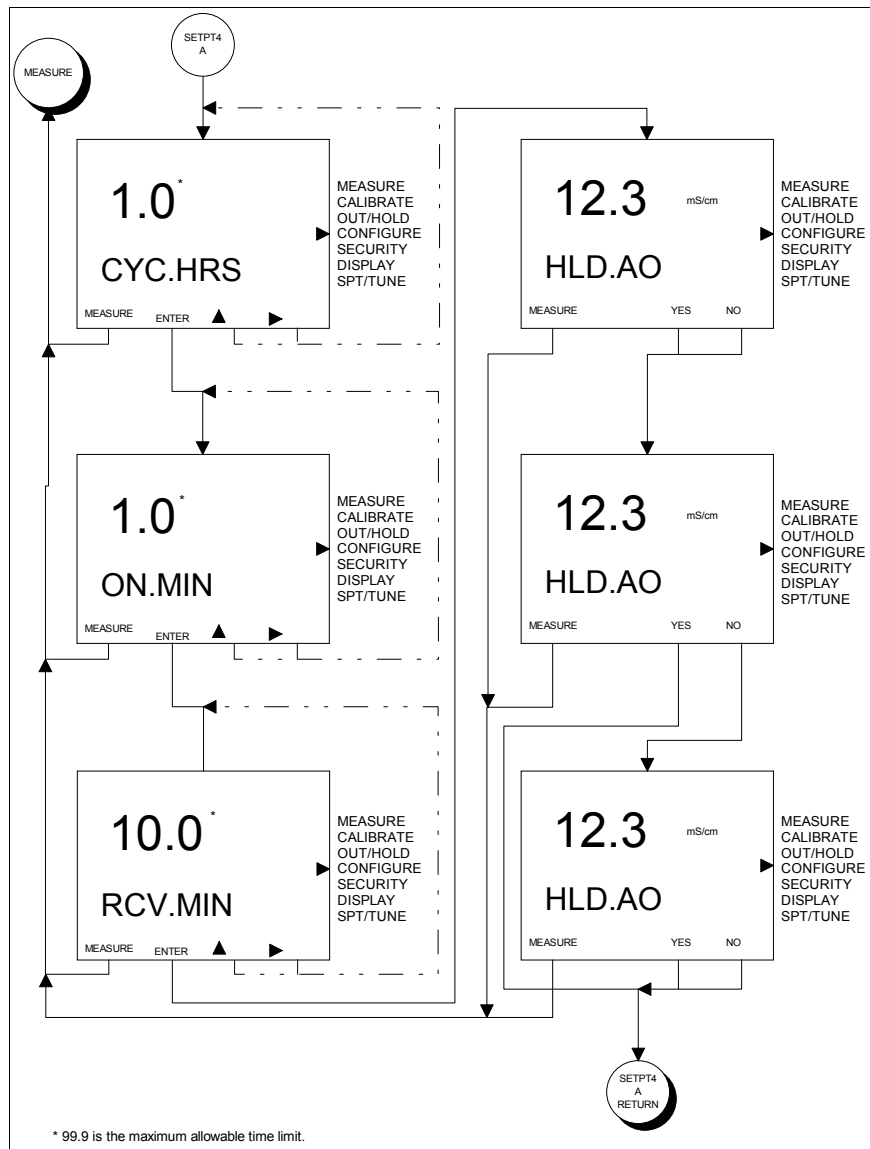

Figure 11-4. Screen Flow Diagram For Setting the Cleaner Relay Output Configure State of Operation.

---

## SECTION 12 - UTILITY MODE

---

### INTRODUCTION

The TB84TE Series analyzer contains a Utility Mode of Operation that provides access to powerful functions not used during normal operating conditions. These functions have been separated into two categories: Factory and User. Factory functions are strictly reserved for ABB personnel.

User functions include Programming Mode, reset configuration to default settings, remove security, reset all parameters to default settings, and software reboot functions.

---

### FACTORY/USER STATE

The Factory and User States of Operation can be accessed using the hidden fifth key located top, center on the keypad. Once the hidden key has been pressed, the textual prompt USER will be displayed in the secondary display region. Pressing the SELECT Smart Key brings the user into the User State, pressing the NEXT Smart Key brings the user to the Factory selection, and pressing the Exit to MEASURE Smart Key escapes back to the Measure Mode.

---

### User State

The User State contains the primary toggle for setting the Programming Mode, three reset functions, and a software reboot operation that initiates the self-test mode. Table 12-1 describes the function of each User State.

The NEXT Smart Key sequentially moves through each of the four User States. This cycle repeats until a state is selected or the escape function is chosen using the Exit to MEASURE Smart Key. To select a state, press the SELECT Smart Key when the desired User State is shown in the secondary display region.

---

**Table 12-1. User States**

<b>State</b>	<b>Function</b>
MODE	Sets the Programming Modes that are available in the Modify Configure State of Operation.
RST.CON	Resets the configuration to factory default settings.
RST.SEC	Resets the security password and removes all security.
RST.ALL	Resets all programming parameters such as configuration, calibration, output/hold, security, secondary display, and setpoint/tune functions to factory default settings.
RST.SFT	Resets the analyzer by repeating the boot-up and self-test procedures.

Figure 12-1 identifies the Smart Key assignments and resulting action. The following sections describe each of the User States and their applicability.

---

**Advanced/Basic Programming Mode User State**

In order to simplify the configuration process for a user who only needs a limited amount of functionality, the TB84TE Series analyzer contains two types of Programming Modes: Basic and Advanced. The Programming Mode is defined by a nomenclature option.

The Basic Programming Mode contains a reduced set of features found in the Advanced Programming Mode. Reducing the available features helps streamline the configuration process. If the TB84TE Series analyzer is ordered with Advanced Programming, the Basic or Advanced Programming Mode can be used.

Contact ABB for information on Advanced Programming upgrades.

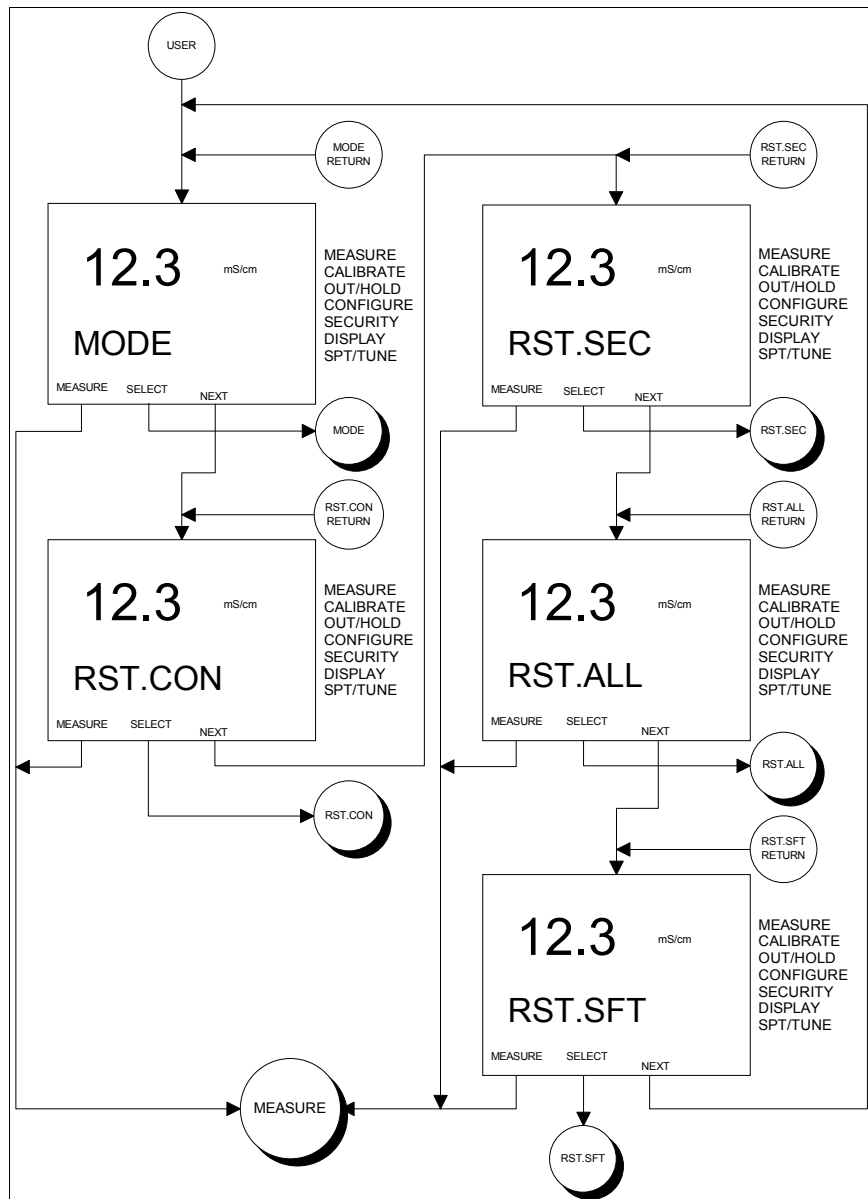

Figure 12-1. Screen Flow Diagram For User States of Operation.

### Reset Configuration User State

The Reset Configuration User State returns the configuration to factory default settings. See the Preface, Configuration Worksheets, for instrument default settings.

---

To reset the configuration to factory defaults, use the following procedure:

- 1) Access the User Mode by pressing the hidden button located top, center on the keypad. The text USER will appear in the secondary display once the hidden button has been pressed.
- 2) Press the SELECT Key to access the User Mode. The text MODE will appear in the secondary display.
- 3) Press the NEXT Key to display RST.CON (i.e., Reset Configuration) text.
- 4) Press the SELECT Key to reset the configuration.
- 5) Enter the security password (if the Configure Mode has been secured) using the ▲ Key to increment the blinking digit and the ► Key to move to the next digit, and press the ENTER Key to enter the password.
- 6) Confirm the reset operation when the text RESET? is displayed by pressing the YES Key, or abort the reset operation by pressing the NO Key.

---

### **Reset Security User State**

The Reset Security User State returns the security to factory default settings. The factory default is security OFF for all applicable modes and states (i.e., Calibrate, Output/Hold, Modify Configure, and Setpoint/Tune).

To remove the security, use the following procedure:

- 1) Access the User Mode by pressing the hidden button located top, center on the keypad. The text USER will appear in the secondary display once the hidden button has been pressed.

- 
- 2) Press the SELECT Key to access the User Mode. The text MODE will appear in the secondary display.
  - 3) Press the NEXT Key until the secondary display region shows RST.SEC (i.e., Reset Security) text.
  - 4) Press the SELECT Key to reset the security.
  - 5) Enter the security password **732** using the ▲ Key to increment the blinking digit and the ► Key to move to the next digit, and press the ENTER Key to enter the password.
  - 6) Confirm the reset operation when the text RESET? is displayed by pressing the YES Key, or abort the reset operation by pressing the NO Key.

---

#### **Reset All User State**

The Reset All User State returns all analyzer parameters back to factory defaults. This includes calibration, output/hold, configuration, security, secondary display, and setpoint/tune values.

To reset all analyzer parameters, use the following procedure:

- 1) Access the User Mode by pressing the hidden button located top, center on the keypad. The text USER will appear in the secondary display once the hidden button has been pressed.
- 2) Press the SELECT Key to access the User Mode. The text MODE will appear in the secondary display.
- 3) Press the NEXT Key until the secondary display region shows RST.ALL (i.e., Reset ALL) text.
- 4) Press the SELECT Key to reset all analyzer parameters.

- 
- 5) Enter the security password **255** using the ▲ Key to increment the blinking digit and the ► Key to move to the next digit, and press the ENTER Key to enter the password.
  - 6) Confirm the reset operation when the text RESET? is displayed by pressing the YES Key, or abort the reset operation by pressing the NO Key.

---

### **Soft Boot User State**

The Soft Boot User State initiates a firmware reset. The firmware reset initiates boot-up and self-test procedures. All programmable instrument parameters are unaffected by this function.

To reboot the analyzer without affecting any instrument parameters, use the following procedure:

- 1) Access the User Mode by pressing the hidden button located top, center on the keypad. The text USER will appear in the secondary display once the hidden button has been pressed.
- 2) Press the SELECT Key to access the User Mode. The text MODE will appear in the secondary display.
- 3) Press the NEXT Key until the secondary display region shows RST.SFT (i.e., Reset ALL) text.
- 4) Press the SELECT Key to initiate the reboot operation.
- 5) Confirm the reboot operation when the text RESET? is displayed by pressing the YES Key, or abort the reset operation by pressing the NO Key.

---

## SECTION 13 - DIAGNOSTICS

---

### INTRODUCTION

The TB84TE Series analyzer performs a number of diagnostic checks on hardware, firmware, and sensor functions. If a nonconforming condition is detected, the user is alerted to faults locally by a flashing FAULT indicating icon, and if configured, remotely by modulating Analog Output One (i.e., Spike Output) and/or energizing a Relay Output (i.e., Diagnostic Relay Output).

Diagnostic faults are interrogated using the FAULT Info Smart Key. A short text string and fault code are alternately shown in the secondary display region. If multiple faults exist, the FAULT Info Smart Key moves the user to the next fault. Once all faults have been interrogated, the analyzer returns to the Measure Mode of Operation.

The following section describes the types of fault conditions and their applicability to the TB84TE Series functionality.

---

### FAULT CODES

Fault conditions are grouped into two categories based on severity. Conditions that result in degradation of analyzer performance are reported as Problem Codes (PC), while conditions that render the analyzer inoperable are reported as Error Codes (EC).

Fault codes are reported in the secondary display region in a first in, first out order (i.e., the first detected fault condition is the first condition that is displayed upon interrogation). All active fault conditions can be viewed at any time while in the Measure Mode using the FAULT Info Smart Key. A flashing Fault icon indicates a new fault condition that has not been interrogated. A non-flashing Fault icon indicates all fault conditions have been interrogated but not resolved. When all fault conditions are resolved, the Fault icon and FAULT Info Smart Key are de-energized.

---

## Problem Codes

---

Problem Codes result from fault conditions that impact the performance of the TB84TE Series analyzer. In most cases, these conditions can be resolved by the user using standard practices.

The occurrence of a Problem Code fault condition triggers the Fault icon to energize, the Spike output to modulate (if configured), and a Diagnostic Relay Output to energize (if configured). These diagnostic indicators provide local and remote reporting capability.

Tables 13-1 and 13-2 contain all the Problem Codes supported by the TB84TE Series analyzer. Each entry lists the Problem Code number, displayed text string, and a short description of the fault. See Section 14, Troubleshooting, for resolving a fault condition.

**Table 13-1. Common Problem Code Definitions**

<b>Problem Codes</b>	<b>Text String</b>	<b>Description</b>
PC1	POLAR	Sensor Polarization detected.
PC6	HI.AO1	Analog Output One above upper range value (+0.4 mA Hystersis).
PC7	LO.AO1	Analog Output One below lower range value (-0.2 mA Hystersis). Fault only applicable for 4-20 mA configurations.
PC8	HI.PV	Process Variable above analyzer range.
PC9	LO.PV	Process Variable below analyzer range.
PC10	HI.TEMP	Temperature above analyzer range.
PC11	LO.TEMP	Temperature below analyzer range.
PC12	HI.T.AD	Open or missing temperature sensor.
PC13	LO.T.AD	Shorted temperature sensor.
PC18	HI.AO2	Analog Output Two above upper range value (+0.4 mA Hystersis).
PC19	LO.AO2	Analog Output Two below lower range value (+0.4 mA Hystersis). Fault only applicable for 4-20 mA configurations.

**Table 13-2. Uncommon Problem Code Definitions**

<b>Problem Codes</b>	<b>Text String</b>	<b>Description</b>
PC20	BAD.SEE	Bad Serial EEPROM or Conductivity Input PCB Assembly.
PC21	NO.F.CAL	Missing factory calibration or non-functional Serial EEPROM.
PC22	BLNK.EE	Blank microprocessor EEPROM.
PC25	ROM.SUM	Incorrect EPROM Checksum.
PC30	R0.F.CAL	Out of range or missing factory calibration for conductivity circuit range zero.
PC31	R1.F.CAL	Out of range or missing factory calibration for conductivity circuit range one.
PC32	R2.F.CAL	Out of range or missing factory calibration for conductivity circuit range two.
PC33	R3.F.CAL	Out of range or missing factory calibration for conductivity circuit range three.
PC34	R4.F.CAL	Out of range or missing factory calibration for conductivity circuit range four.
PC35	G0.F.CAL	Out of range or missing factory calibration for secondary process variable range zero.
PC36	G1.F.CAL	Out of range or missing factory calibration for secondary process variable range one.
PC37	G2.F.CAL	Out of range or missing factory calibration for secondary process variable range two.
PC38	G3.F.CAL	Out of range or missing factory calibration for secondary process variable range three.
PC39	G4.F.CAL	Out of range or missing factory calibration for secondary process variable range four.
PC45	BA.F.CAL	Out of range or missing factory calibration for 3k Balco temperature sensor.
PC46	PT.F.CAL	Out of range or missing factory calibration for Pt100 temperature sensor.
PC48	PK.F.CAL	Out of range or missing factory calibration for Pt1000 temperature sensor.
PC50	R0.CHKS	Incorrect or missing conductivity circuit range zero checksum.
PC51	R1.CHKS	Incorrect or missing conductivity circuit range one checksum.
PC52	R2.CHKS	Incorrect or missing conductivity circuit range two checksum.
PC53	R3.CHKS	Incorrect or missing conductivity circuit range three checksum.
PC54	R4.CHKS	Incorrect or missing conductivity circuit range four checksum.
PC55	G0.CHKS	Incorrect or missing secondary process variable range zero checksum.

<b>Problem Codes</b>	<b>Text String</b>	<b>Description</b>
PC56	G1.CHKS	Incorrect or missing secondary process variable range one checksum.
PC57	G2.CHKS	Incorrect or missing secondary process variable range two checksum.
PC58	G3.CHKS	Incorrect or missing secondary process variable range three checksum.
PC59	G4.CHKS	Incorrect or missing secondary process variable range four checksum.
PC65	BA.CHKS	Incorrect or missing 3k Balco temperature sensor checksum.
PC66	PT.CHKS	Incorrect or missing Pt100 temperature sensor checksum.
PC68	PK.CHKS	Incorrect or missing Pt1000 temperature sensor checksum.
PC70	HI.G.L.AD	Secondary process variable signal above analyzer A/D range.
PC71	LO.G.L.AD	Secondary process variable signal below analyzer A/D range.

## **Error Codes**

Error Codes result from fault conditions that render the TB84TE Series analyzer inoperable. In most cases, these conditions can not be resolved by the user using standard methods.

The occurrence of an Error Code fault condition triggers the Fault icon to energize and the Safe Mode outputs to enable (i.e., the Analog Output One and Two currents are fixed high or low based on the configured Safe Mode levels). These diagnostic indicators provide local and remote reporting capability.

Table 13-3 contains all the Error Codes supported by the TB84TE Series analyzer. Each entry lists the Error Code number, displayed text string, and a short description of the fault condition. See Section 14, Troubleshooting, for resolving a fault condition.

**Table 13-3. Error Code Definitions**

<b>Error Codes</b>	<b>Text String</b>	<b>Description</b>
EC1	HI.PV.AD	Over range Process Variable A/D.
EC2	LO.PV.AD	Under range Process Variable A/D.
EC3	PH.PCB	pH/ORP/pION board with conductivity firmware.
EC4	TC.PCB	Toroidal conductivity board with four-electrode conductivity firmware.
EC5	DO.PCB	Dissolved Oxygen board with four-electrode conductivity firmware.
EC6	TE.PCB	Two-electrode conductivity board with four-electrode conductivity firmware.
EC7	EC.PCB	Electrode conductivity board with four-electrode conductivity firmware.

**Calibration Diagnostic Messages**

The TB84TE Series analyzer performs automatic efficiency and offset calculations relative to a theoretically perfect conductivity and/or temperature sensor during each calibration cycle. Calibration constants are retained for future interrogation using the Edit Calibrate State. The calibration constants that are displayed are Slope and Offset for the Process Variable and Slope and Offset for the Temperature.

A Slope of less than 0.2 or greater than 5 indicates a potentially bad process calibration point or poorly performing sensor. In these cases, the text string BAD.CAL (i.e., bad calibration) is displayed in the secondary display region. The user is returned to the beginning of the calibration cycle after the bad calibration has been reported.

An Offset value of less than -20  $\mu\text{S}/\text{cm}$  for a nominal cell constant value of 1.00, -4  $\mu\text{S}/\text{cm}$  for a nominal cell constant value of 0.1, and -0.800  $\mu\text{S}/\text{cm}$  for a nominal cell constant value of 0.01 or greater than 20  $\mu\text{S}/\text{cm}$  for a nominal cell constant value of 1.00, 4  $\mu\text{S}/\text{cm}$  for a nominal cell constant value of 0.1, and 0.800  $\mu\text{S}/\text{cm}$  for a nominal cell constant value of 0.01 also indicates a potentially bad process calibration or poorly performing sensor.

---

Again, a bad calibration will be reported, and the user returned to the beginning of the calibration cycle.

For temperature, a bad calibration will be reported and calibration values will not be accepted for Slope values that are less than 0.2 or greater than 1.5 and Offset values that are less than -40°C or greater than +40°C. As with conductivity calibrations, temperature calibrations use smart software routines that automatically adjust the Slope, Offset, or both values based on the calibration value being entered and calibration history if it exists.

---

### **Additional Diagnostic Messages**

Other diagnostic messages may appear during analyzer programming. These messages include BAD.VAL (i.e., bad value) and DENIED.

BAD.VAL indicates the attempted numeric entry of a value which is out of the allowed analyzer range. See Table 1-3, Specifications, for analyzer range limits.

DENIED indicates incorrect entry of a security password. See Section 9, Security Mode, for information on the Security Mode of Operation.

RAM.ERR indicates a Random Access Memory read/write error. The analyzer will automatically reset when this error has been encountered. If the analyzer continues to reset, contact ABB for problem resolution.

---

## SECTION 14 - TROUBLESHOOTING

---

### INTRODUCTION

This section provides troubleshooting information for the TB84TE Series analyzer and associated sensor. Using Table 14-1, problem and error conditions can be identified and the corrective action for these conditions can be tested. Refer to Section 13, Diagnostics, for descriptions of problem and error code conditions.

---

### ANALYZER TROUBLESHOOTING

Table 14-1. Analyzer Troubleshooting Guide

<b>Problem Code</b>	<b>Problem Text String</b>	<b>Corrective Action</b>
PC1	POLAR	<ol style="list-style-type: none"><li>1) Verify process conditions, specifically conductivity, are within values identified in Table 3-1, Specifications.</li><li>2) Verify sensor does not have any trapped air bubbles within the sensing cavity (i.e., near the center sensing electrode). Trapped air reduces sensor surface area and will affect the accuracy of the displayed conductivity and output current.</li><li>3) Verify sensor is clean. Remove any foreign material. Clean sensor then verify sensor responds to conductivity standard solutions. If sensor does not respond, electronically test sensor as described in Sensor Electronic Test found later in this section. Replaced sensor if sensor does not respond. See Section 14, Maintenance, for cleaning methods.</li><li>4) Verify sensor wiring is properly connected.</li></ol>
PC6	HI.A01	<ol style="list-style-type: none"><li>1) Verify process conditions are within configured output range. If process variable is outside configured range, increase output range.</li><li>2) Verify TB84TE is configured for the correct type of temperature compensation.</li><li>3) Verify sensor wiring is in good condition and is properly connected.</li><li>4) Remove any liquids, oils, scales or corrosion from TB84TE terminal block or extension cable junction box terminals.</li><li>5) Clean sensor and perform a process calibration.</li><li>6) Conduct a temperature calibration. If a temperature sensor is not being used, verify the analyzer is configured for TMP.SNS "NONE" and the proper process temperature has been set.</li><li>6) Electronically test the sensor and temperature compensator. Replace sensor if sensor does not meet requirements.</li></ol>

<b>Problem Code</b>	<b>Problem Text String</b>	<b>Corrective Action</b>
PC7	LO.AO2	1) See PC6 corrective actions.
PC8	HI.PV	1) Verify process conditions are within analyzer range. Process variable must be within analyzer range. 2) Also See PC4 corrective actions.
PC9	LO.PV	1) See PC8 corrective actions.
PC10	HI.TEMP	1) Verify process conditions are within analyzer range. Process variable must be within analyzer range. 2) Also see PC6 corrective actions.
PC11	LO.TEMP	1) See PC10 corrective actions.
PC12	HI.T.AD	1) See PC10 corrective actions. If all items check out, implement item 2. 2) Replace Two-Electrode Conductivity PCB Assembly.
PC13	LO.T.AD	1) See PC12 corrective actions.
PC18	HI.AO2	1) See PC6 corrective actions.
PC19	LO.AO2	2) See PC6 corrective actions.
PC20	BAD.SEE	1) Input PCB Factory calibration constants can not be loaded. Calibrate sensor and order replacement Two-Electrode Conductivity PCB Assembly. Existing PCB should properly function until new assembly is received.
PC21	NO.F.CAL	1) Contact Factory for calibration procedure. Calibrate sensor for short-term usage until factory calibration can be performed or a new Two-Electrode Conductivity PCB Assembly can be installed.
PC22	BLNK.uP	1) Cycle analyzer power. 2) Contact Factory.
PC25	ROM.SUM	1) See PC22 corrective action.
PC30	R0.F.CAL	1) Contact Factory for calibration or replacement procedures. Calibrate sensor for short-term usage until a factory calibration can be performed.
PC31	R1.F.CAL	1) See PC30 corrective action.
PC32	R2.F.CAL	1) See PC30 corrective action.
PC33	R3.F.CAL	1) See PC30 corrective action.
PC34	R4.F.CAL	1) See PC30 corrective action.
PC35	G0.F.CAL	1) Contact Factory for calibration or replacement procedures. Calibrate sensor for short-term usage until a factory calibration can be performed.
PC36	G1.F.CAL	1) See PC35 corrective action.

<b>Problem Code</b>	<b>Problem Text String</b>	<b>Corrective Action</b>
PC37	G2.F.CAL	1) See PC35 corrective action.
PC38	G3.F.CAL	1) See PC35 corrective action.
PC39	G4.F.CAL	1) See PC35 corrective action.
PC45	BA.F.CAL	1) Contact Factory for calibration or replacement procedures. Calibrate temperature sensor for short-term usage until factory calibration can be performed.
PC46	PT.F.CAL	1) See PC45 corrective action.
PC47	RT.F.CAL	1) See PC45 corrective action.
PC50	R0.CHKS	1) See PC30 corrective action.
PC51	R1.CHKS	1) See PC30 corrective action.
PC52	R2.CHKS	1) See PC30 corrective action.
PC53	R3.CHKS	1) See PC30 corrective action.
PC54	R4.CHKS	1) See PC30 corrective action.
PC55	G0.CHKS	1) See PC35 corrective action.
PC56	G1.CHKS	1) See PC35 corrective action.
PC57	G2.CHKS	1) See PC35 corrective action.
PC58	G3.CHKS	1) See PC35 corrective action.
PC59	G4.CHKS	1) See PC35 corrective action.
PC65	BA.CHKS	1) See PC45 corrective action.
PC66	PT.CHKS	1) See PC45 corrective action.
PC67	RT.CHKS	1) See PC45 corrective action.
PC70	HI.G.L.AD	1) Input PCB secondary process variable measurement failure exists. Disable diagnostics and order replacement Two-Electrode Conductivity PCB Assembly. Existing PCB should properly function until new assembly is received.
PC71	LO.G.L.AD	1) See PC70 corrective action.

---

**WARNING**

All error conditions are considered catastrophic. When such an error has been reported, the analyzer should be replaced with a known-good analyzer. The non-functional analyzer should be returned to the factory for repair. Contact the factory for a Return Materials Authorization (RMA) number.

---

**INSTRUMENT TROUBLESHOOTING**

When analyzer is suspected as the problem source, the analyzer can be evaluated using a decade resistance source or a set of resistors. These resistor simulate the load measured by the sensor and can be an easy way to check the operation of the analyzer.

---

**Instrument Electronic Test**

Remove the sensor connections from the analyzer and complete the following steps:

- 1) Connect the appropriate resistor, based on temperature sensor configuration, across the temperature sensor input (i.e., TB2-5 and TB2-6) or configure the analyzer for manual temperature compensation with the temperature set to 25°C.
- 2) Connect a decade resistance source or the appropriate resistor across the Green and Black Drive connections (i.e., TB2-1 and TB2-4).

Note: The analyzer calibration values must be set back to those entered at factory in order for this procedure to be valid. The reset calibration feature resets all calibration to factory values. Before putting the analyzer back into service, be sure to perform a temperature, process, and output calibration.

Using the Table 14-2, compare the applied resistance value against the displayed value.

Table 14-1. Sensor Simulation Values

Nominal Cell Constant	Variable Resistance (Ohms)	Desired Display Value	Displayed Value
1.00	Open	0.0 $\mu\text{S}/\text{cm}$	
	5,000	200.0 $\mu\text{S}/\text{cm}$	
	1,000	1000.0 $\mu\text{S}/\text{cm}$	
	500.0	2.00 mS/cm	
	100.0	10.00 mS/cm	
	50.0	19.99 mS/cm (OR)	
0.10	Open	0.00 $\mu\text{S}/\text{cm}$	
	50,000	2.00 $\mu\text{S}/\text{cm}$	
	5,000	20.0 $\mu\text{S}/\text{cm}$	
	1,000	100.0 $\mu\text{S}/\text{cm}$	
	500	200 $\mu\text{S}/\text{cm}$	
	100	1000 $\mu\text{S}/\text{cm}$	
	50	1999 $\mu\text{S}/\text{cm}$ (OR)	
0.01	Open	0.000 $\mu\text{S}/\text{cm}$	
	100,000	0.100 $\mu\text{S}/\text{cm}$	
	50,000	0.200 $\mu\text{S}/\text{cm}$	
	5,000	2.00 $\mu\text{S}/\text{cm}$	
	1,000	10.00 $\mu\text{S}/\text{cm}$	
	500	20.0 $\mu\text{S}/\text{cm}$	
	100	100.0 $\mu\text{S}/\text{cm}$	
	50	199.0 $\mu\text{S}/\text{cm}$ (OR)	

### SENSOR TROUBLESHOOTING

If the sensor is suspected of being the source of problems, a quick visual inspection in many cases will identify the problem. If nothing can be seen, a few electrical tests using a digital multimeter can be performed to determine if the sensor is at fault. Some of these tests can be performed with the sensor either in or out of the process stream.

---

## Visual Sensor Inspection

Remove the sensor from the process and visually check the following:

### Sensor body

Inspect the sensor body for cracks and distortions. If any are found, contact ABB for alternative sensor styles and materials.

### Cable and connectors

Inspect the sensor cable for cracks, cuts, or shorts. If a junction box and/or extension cable are used, check for moisture, oil, corrosion, and/or particulates where connections are made. All connections must be dry, oil-free, corrosion-free, and particulate-free. Even slight amounts of moisture, corrosion, and particulates can short sensor signals and affect conductivity readings. Check to see that all wiring is not shorting against any metal, conduit, or earth grounds. See Section 15, Maintenance, for sensor cleaning procedures.

### O-ring seals

Inspect the O-ring seals for attack by the process liquid. If the O-rings show evidence of corrosion, distortion, or deterioration, contact ABB for alternate material choices.

---

## Sensor Electronic Test

Conductivity sensors can be electronically tested to verify the integrity of the sensor and cable. The sensor leads and automatic temperature compensator leads must be disconnected from the analyzer before any tests can be performed. Additionally, these tests require a Digital Multimeter (DMM) that has a conductance function capable of 0 to 200 nS and a resistance function capable of 0 to 20 kohms.

The automatic temperature compensator can be tested with the sensor in the process and is tested using the following procedure:

---

1. Check the resistance of the Temperature Compensator by measuring the resistance between the yellow and blue Temperature Compensator leads.

For a 3 kohm Balco RTD, the expected resistance can be calculated using:

$$R_{TC} = (T - 25) \cdot 0.0045 + 3000$$

where T is in degrees Celsius. The measured resistance should be within the expected value by  $\pm 15\%$ .

For a Pt100 RTD, the expected resistance can be calculated using:

$$R_{TC} = 100 \cdot (T - 0) \cdot 0.385$$

where T is in degrees Celsius. The measured resistance should be within the expected value by  $\pm 5\%$ .

For a Pt1000 RTD, the expected resistance can be calculated using:

$$R_{TC} = 1000 \cdot (T - 0) \cdot 3.85$$

where T is in degrees Celsius. The measured resistance should be within the expected value by  $\pm 5\%$ .

Moisture intrusion behind the sensor electrode seal can be detected with the sensor removed from the process, thoroughly dried, and tested using the following procedure:

1. Check the conductance between the yellow Temperature Compensator lead and each of the other sensor leads (i.e., green, black, and heavy green leads). The reading must be less than 0.05 nS.

---

2. Check the conductance between the green Drive lead and each of the other sensor leads (i.e., black and heavy green leads). The reading must be less than 0.05 nS.

3. For sensors with metal bodies, check the conductance between each of the sensor/temperature lead (i.e., black, green, yellow, blue, and heavy green leads) and the sensor body. The reading must be less than 0.05 nS.

4. Check the conductance between the heavy green lead (i.e., Shield) and each of the other sensor leads (i.e., blue, yellow, black, green, red, and white leads). The reading must be less than 0.05 nS.

---

## SECTION 15 - MAINTENANCE

---

### INTRODUCTION

The reliability of any stand-alone product or control system is affected by maintenance of the equipment. ABB recommends that all equipment users practice a preventive maintenance program that will keep the equipment operating at an optimum level.

Personnel performing preventive maintenance should be familiar with the TB84TE Series analyzer.

<b>WARNING</b>
----------------

<p>Allow only qualified personnel (refer to INTENDED USER in SECTION 1 - INTRODUCTION) to commission, operate, service or repair this equipment. Failure to follow the procedures described in this instruction or the instructions provided with related equipment can result in an unsafe condition that can injure personnel and damage equipment.</p>
-----------------------------------------------------------------------------------------------------------------------------------------------------------------------------------------------------------------------------------------------------------------------------------------------------------------------------------------------------------

---

### PREVENTIVE MAINTENANCE

Table 15-1 is the preventive maintenance schedule and check list for the TB84TE Series analyzer. The table lists the preventive maintenance tasks in groups according to their specified maintenance interval. The maintenance intervals are recommendations and may vary depending on the environment of the analyzer's location and the process application. As a minimum, these recommended maintenance tasks should be performed during an extended process shutdown. Tasks in Table 15-1 are self-explanatory. For sensor cleaning procedures, refer to CLEANING THE SENSOR.

Table 15-1. Preventive Maintenance Schedule

Preventive Maintenance Tasks	Interval (months)
Check and clean all wiring and wiring connections.	12
Clean and inspect sensor.	As required.
Clean and lubricate all gaskets and O-rings, or replace and lubricate if damage is evident.	Each time seals are broken.
Calibrate analyzer output.	12
Calibrate analyzer sensor input.	As required.

### Cleaning the Sensor

ABB conductivity sensors are cleaned using one or a combination of the following methods. These are recommendations and may not be suitable for all applications. Other cleaning methods may be developed that better suit particular applications. When cleaning, observe all safety precautions required for handling chemicals. When handling chemicals, always use gloves, eye protection, safety shield, and similar protective items, and consult **Material Safety Data Sheets**.

**WARNING**

Consider the material compatibility between cleaning fluids and process liquids. Incompatible fluids can react with each other causing injury to personnel and equipment damage.

**WARNING**

Use solvents only in well ventilated areas. Avoid prolonged or repeated breathing of vapors or contact with skin. Solvents can cause nausea, dizziness, and skin irritation. In some cases, overexposure to solvents has caused nerve and brain damage. Solvents are flammable - do not use near extreme heat or open flame.

---

**Acid Dip** Dip the tip of the sensor into a one to five percent hydrochloric acid (HCl) solution until this region is free of the unwanted coating. Minimize exposure of any metal on the sensor to this corrosive cleaning solution. This method removes scale from water hardness. After dipping, thoroughly rinse sensor with clean water.

**Solvent Dip** Dip the sensor into a solvent such as isopropyl alcohol. Remove solvent using a clean cloth. Do not use solvents that are known to be incompatible with the plastic of the sensor. This method removes organic coatings. After dipping, wash sensor with soap and warm water.

**Physical Cleaning** Use a rag, acid brush, or tooth brush to remove especially thick scales and accumulations.



---

## SECTION 16 - REPLACEMENT PROCEDURES

---

### INTRODUCTION

Due to the modular design of the TB84TE Series analyzer, the replacement of an assembly can be easily completed. Replacements are available for each major assembly. These include the input PCB, microprocessor PCB, power supply PCB, front bezel, shell, and rear cover assemblies. This section provides removal and installation procedures for these assemblies. Use Figure 16-1 as a reference during removal and installation procedures.

**NOTE:** Refer to Section 3 for special handling procedures when removal of electronic assemblies is required.

<b>WARNING</b>	Substitution of any components other than those assemblies listed in this section will compromise the certification listed on the analyzer nameplate. Invalidating the certifications can lead to unsafe conditions that can injure personnel and damage equipment.
----------------	---------------------------------------------------------------------------------------------------------------------------------------------------------------------------------------------------------------------------------------------------------------------

<b>WARNING</b>	Do not disconnect equipment unless power has been switched off at the source or the area is known to be nonhazardous. Disconnecting equipment in a hazardous location with source power on can produce an ignition-capable arc that can injure personnel and damage equipment.
----------------	--------------------------------------------------------------------------------------------------------------------------------------------------------------------------------------------------------------------------------------------------------------------------------

---

### ELECTRONIC ASSEMBLY REMOVAL/REPLACEMENT

1. Turn off power to the analyzer. Allow at least 1 minute for the analyzer to discharge.
2. Remove the Front Bezel Assembly by unscrewing the four captive screws and lightly pulling the bezel from the shell.

---

3. Remove the four 6-32 machine screws that retain the Power Supply and Input PCB assemblies if both assemblies or the Microprocessor PCB Assembly are being replaced.

4. Release the keypad ribbon cable connector latches located on the outside edges of the connector and remove the ribbon cable from the connector.

5. Remove the four 6-32 machine screws that retain the Microprocessor PCB Assembly.

6. Replace the appropriate PCB assembly and follow the reverse of this procedure to re-assemble the analyzer.

---

#### **FRONT BEZEL ASSEMBLY REMOVAL/REPLACEMENT**

1. Turn off power to the analyzer. Allow at least 1 minute for the analyzer to discharge.

2. Remove the Power Supply, Input, and Microprocessor PCB Assemblies as described in Electronic Assembly Removal/Replacement procedure.

3. Attach the Power Supply, Input, and Microprocessor PCB Assemblies to the new Front Bezel Assembly, and install it into the Shell Assembly as described in Electronic Assembly Removal/Replacement procedure.

---

#### **SHELL ASSEMBLY REMOVAL/REPLACEMENT**

1. Turn off power to the analyzer. Allow at least 1 minute for the analyzer to discharge.

2. Remove the Front Bezel Assembly by unscrewing the four captive screws and lightly pulling the bezel from the shell.

3. Remove the Rear Cover Assembly by unscrewing the four captive screws.

4. Replace the old Shell Assembly with the new one.

5. Install the Rear Cover and Front Bezel Assemblies and tighten the eight captive screws.

---

### REAR COVER ASSEMBLY REMOVAL/REPLACEMENT

1. Turn off power to the analyzer. Allow at least 1 minute for the analyzer to discharge.
2. Remove the Rear Cover Assembly by unscrewing the four captive screws.
3. Replace with the new Rear Cover Assembly.
4. Tighten the four captive screws.

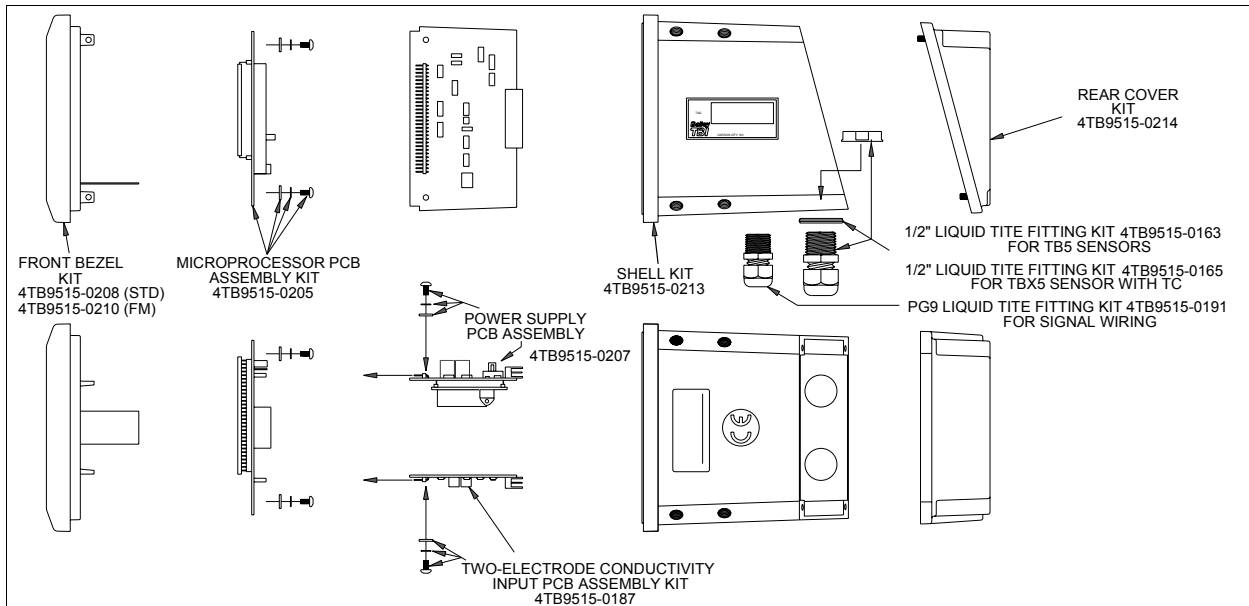

Figure 16-1. TB84TE Series Exploded View Showing Kit Assignments.



---

## SECTION 17 - SUPPORT SERVICES

---

### INTRODUCTION

ABB is ready to help in the use and repair of its products. Requests for sales and/or application services should be made to the nearest sales or service office.

Factory support in the use and repair of the TB84TE Series analyzer can be obtained by contacting:

ABB  
2175 Lockheed Way  
Carson City, NV 89706  
Phone: 1(775)883-4366  
Facsimile: 1(775)883-4373  
Web Site: [www.abb.com/instrumentation](http://www.abb.com/instrumentation)

---

### RETURN MATERIALS PROCEDURES

If any equipment should need to be returned for repair or evaluation, please contact ABB at (775)883-4366, or your local ABB representative for a Return Materials Authorization (RMA) number. At the time the RMA number is given, repair costs will be provided, and a customer purchase order will be requested. The RMA and purchase order numbers must be clearly marked on all paperwork and on the outside of the return package container (i.e., packing box).

**Equipment returned to ABB with incorrect or incomplete information may result in significant delays or non-acceptance of the shipment.**

---

### REPLACEMENT PARTS

When making repairs at your facility, order spare part kits from an ABB sales office. Provide the following information.

1. Spare parts kit description, part number, and quantity.
2. Model and serial number (if applicable).

3. ABB instruction manual number, page number, and reference figure that identifies the spare parts kit.

When you order standard parts from ABB, use the part numbers and descriptions listed in **RECOMMENDED SPARE PART KITS** in this section. Order parts without commercial descriptions from the nearest ABB sales office.

---

**RECOMMENDED SPARE PART KITS**

Table 17-1. Spare Parts Kits

<b>Part Number</b>	<b>Description</b>
4TB9515-0124	Pipe Mount Kit
4TB9515-0125	Hinge Mount Kit
4TB9515-0123	Panel Mount Kit
4TB9515-0156	Wall Mount Kit
4TB9515-0208	Front Bezel Kit - Standard
4TB9515-0210	Front Bezel Kit - FM Version
4TB9515-0213	Shell Kit
4TB9515-0214	Rear Cover Kit
4TB9515-0163	½" Liquid-Tite Cable Grip Fitting Kit - Compatible with TBX5 Sensors
4TB9515-0165	½" Liquid-Tite Cable Grip Fitting Kit - Compatible with TB5 Sensors
4TB9515-0191	PG9 Liquid-Tite Cable Grip Fitting Kit - Compatible with most signal cabling sizes
4TB9515-0198	Complete Cable Grip Kit - Two ½" Liquid-Tite Cable Grips (p/n 4TB9515-0165) and three PG9 Liquid-Tite Cable Grips (p/n 4TB9515-0165)
4TB9515-0207	Power Supply PCB Assembly Kit
4TB9515-0199	Microprocessor PCB Assembly Kit w/ TB84PH ROM
4TB9515-0201	Microprocessor PCB Assembly Kit w/ TB84EC ROM

Part Number	Description
4TB9515-0205	Microprocessor PCB Assembly Kit w/ TB84TE ROM
4TB9515-0203	Microprocessor PCB Assembly Kit w/ TB84TC ROM
4TB9515-0153	pH/ORP/pION Input PCB Assembly Kit - TB84PH
4TB9515-0176	Four-Electrode Input PCB Assembly Kit - TB84EC
4TB9515-0187	Two-Electrode Input PCB Assembly Kit - TB84TE
4TB9515-0226	Toroidal Input PCB Assembly Kit - TB84TC
4TB9515-0164	BNC/TC to TB84PH Pin Adapter
4TB9515-0166	BNC to TB84PH Pin Adapter w/ ½" Liquid-Tite Fitting For Sensors w/ BNC (i.e., TB5 Sensors)



---

## APPENDIX A - TEMPERATURE COMPENSATION

---

### GENERAL

The TB84TE Series analyzer has a variety of standard conductivity temperature compensation options. These include manual (0.1 N KCl), standard automatic (0.1 N KCl), temperature coefficient (0 to 9.99%/°C), and user-defined.

Additionally, three specialized types of automatic temperature compensation are available for the measurement of pure water using a nominal cell constant of 0.01. These types include neutral salt, trace base, and trace acid.

The concentration analyzer configuration offers the same temperature compensation options as for the standard conductivity analyzer configuration.

---

### CONDUCTIVITY AND CONCENTRATION ANALYZER

For these two types of analyzer, seven different types of temperature compensation are available. Manual temperature compensation is based on 0.1 N KCl and has an adjustable reference temperature for Advanced configurations. The default reference temperature for Basic and Advanced configurations is 25 degrees Celsius.

Automatic temperature compensation can be set to one of several temperature compensation types. When automatic compensation is configured, the analyzer will measure the process temperature via the resistive temperature device located either in the conductivity sensor or external to the sensor, and will automatically adjust the raw conductivity to the reference.

The standard KCl temperature compensation option characterizes the temperature effect of 0.1 N KCl and has the following data break-points:

Temperature (°C)	$K_{REF}/K$
0	1.80
5	1.57
10	1.38
15	1.22
20	1.10
25	1.00
30	0.91
50	0.69
75	0.50
100	0.38
128	0.30
156	0.25
306	0.18

The temperature coefficient option allows for a fixed correction which is based on a percentage change of the reference conductivity (i.e., conductivity at the reference temperature - typically 25°C) per degree Celsius. The temperature compensation factor is derived from the equation:

$$TC.COEF = \frac{\left(\frac{K_T}{K_{REF}} - 1.0\right) 100.0}{T - 25.0}$$

where:

and TC.COEF = percentage change in the reference conductivity per degree Celsius.

---

$K_T$  = conductivity at temperature T ( $^{\circ}\text{C}$ ).

$K_{\text{REF}}$  = conductivity at the standard temperature of  $25^{\circ}\text{C}$ .

T = temperature of the solution in degrees Celsius.

Typical ranges for temperature compensation coefficients are:

Acids = 1.0 to 1.6%/ $^{\circ}\text{C}$ .

Bases = 1.8 to 2.0%/ $^{\circ}\text{C}$ .

Salts = 2.2 to 3.0%/ $^{\circ}\text{C}$ .

Neutral Water = 2.0%/ $^{\circ}\text{C}$ .

The user-defined temperature compensation option allows the ability to curve fit a temperature to conductivity relationship using six  $K/K_{\text{REF}}$  break-points and temperature values. Each break-point value should be chosen to provide the closest fit to the actual temperature in degrees  $^{\circ}\text{C}$  versus  $K/K_{\text{REF}}$  relationship.

---

#### **PURE WATER TEMPERATURE COMPENSATION**

When using a conductivity sensor with a nominal cell constant of 0.01, three pure water temperature compensation options are available. These include neutral salt (NEUTRL), trace acid (ACID), and trace base (BASE). As with all other temperature compensation options, the reference temperature is adjustable with a default value of 25 degrees Celsius for Advanced configurations and is permanently set to 25 degrees Celsius for Basic configurations.

Temperature compensation for pure water is a polynomial based on data from T.S. Light. This equation only compensates for variations in conductivity of pure water. All three types of pure compensation use this polynomial in addition to the list solute (i.e., Acid, Base, and Neutral Salt).

For water having a conductivity value greater than 0.5  $\mu\text{S}/\text{cm}$ , temperature compensation for the effect of pure water becomes insignificant compared to the effects brought about by the solute. Using pure water compensation for water greater than 0.5  $\mu\text{S}/\text{cm}$  will not cause errors; however, the compensation on solute effects (i.e., neutral salt, trace acid, or trace base) may not accurately characterize the process liquid.

The pure water and solute polynomials take the form:

$$\text{Factor } K_0 K_1 T K_2 T^2 K_3 T^3 K_4 T^4 K_5 T^5 K_6 T^6$$

Coefficient values (i.e.,  $K_0$ ,  $K_1$ , etc.) for pure water and solute effects are shown below.

Coef.	Pure Water	Salt	Trace Acid	Trace Base
$K_0$	1.170848E-02	0.532688	0.7000	0.5700
$K_1$	9.101055E-04	1.439182E-02	0.0120	0.0172
$K_2$	2.132244E-07	2.852080E-04	-	-
$K_3$	4.548839E-07	-6.504617E-06	-	-
$K_4$	-4.042016E-11	9.640603E-08	-	-
$K_5$	0.0	-6.982205E-10	-	-
$K_6$	0.0	1.887667E-12	-	-

---

## APPENDIX B - CONCENTRATION PROGRAMMING

---

### GENERAL

The concentration analyzer configuration consists of a user-defined option. The user-defined option provides a six-point, five-segment linear approximation of a conductivity-to-concentration curve. For this option, custom units can be used by either selecting one of three engineering unit icons and/or entering a six-character, alphanumeric character string.

---

### USER PROGRAMMED CONCENTRATION TO CONDUCTIVITY CURVES

The TB84TE Series concentration analyzer can be use in any range and with any ABB Model TB2 Two-Electrode sensor. The user-defined option allows the characterization of a concentration-to-conductivity curve which has been determined separately in a laboratory or from published data such as the **International Critical Tables**. This curve must be segmented into five straight lines and programmed into the function generator using the format as illustrated in Figures B-1 through B-5.

Unlike other concentration analyzers, users may enter any conductivity and concentration values in an ascending or descending method. Use the following rules when entering data for a Concentration Analyzer configuration:

1. Point 1 for both conductivity and concentration is always the 0% (i.e., 0 or 4 mA) output point.
2. Point 6 for both conductivity and concentration is always the 100% (i.e., 20 mA) output point.
3. All conductivity must be sequentially ascending. Concentration points can be either sequentially ascending or descending.

- 
4. If a reverse acting output is desired, swap the output range values either in the modify configure state or the output/hold mode.
  5. The output range (i.e., 0 or 4 and 20 mA output range) can not exceed Point 1 and 6 concentration range; however, the output range can be compressed using the rerange (RERNGE) function in the OUT/HOLD mode of operation.

Users may also define their own engineering units by selecting either the PPM, PPB, or % icon. This icon will be energized in the primary display. If one of these icons is not applicable, the option of not using an icon is available. In these cases, the six-character, alphanumeric description field can be used to permanently or temporarily display process variable information in the secondary display field.

---

## APPENDIX C - PROGRAMMING TEXT STRING GLOSSARY

---

### GENERAL

When programming the TB84TE Series analyzer, the six-character, alphanumeric region will display a wide variety of text prompts. In many cases, these prompts are abbreviations or word fragments. This section contains a complete list of the text prompts and their full text equivalent.

---

### GLOSSARY OF PROGRAMMING TEXT PROMPTS

Table C-1. Glossary of Text Prompts

TEXT STRING	DESCRIPTION
0-20MA	0 to 20 Milliamp Output Range State
0MA.PT	0 Milliamp Point
20MA.PT	20 Milliamp Point
3K.BLCO	3 kohm Balco (Temperature Compensation)
4-20MA	4 to 20 Milliamp Output Range State
4.7K.RTD	4.75 kohm RTD Network
4MA.PT	4 Milliamp Point
AAAAAA	Alphanumeric Prompt
ACID	Acid
ADVNC D	Advanced (Programming Mode)
ALL	All Diagnostic Fault Conditions
ANALZR	Analyzer State
A01.CAL	Analog Output One Calibrate State
A02.CAL	Analog Output Two Calibrate State
A01.OUT	Analog Output One Range State
A02.OUT	Analog Output Two Range State
A01.RNG	Analog Output One Rerange State
A02.RNG	Analog Output Two Rerange State
A01.SEC	Analog Output One Damping Value in Seconds
A02.SEC	Analog Output Two Damping Value in Seconds
AUTO	Automatic Temperature Compensation

TEXT STRING	DESCRIPTION
BAD.CAL	Bad Calibration - Entered values caused the calculated values to exceed maximum values.
BAD.VAL	Bad Value - Entered value exceeded maximum allowable value for the entered parameter.
BASE	Base
BASIC	Basic Programming State
CALIBR	Calibrate Mode
CELL	Sensor Cell Constant
CLNR	Cleaner Relay Output State
CON.CAL	Conductivity or Concentration Calibrate State
CONCEN	Concentration
COND	Conductivity
CONFIG	Configure Mode
CYC.MIN	Cycle Time for Cycle Timer Relay Output in Minutes
CYC.HRS	Cycle Time for Cleaner Relay Output in Hours
D.P.POS	Decimal Point Position
DAMPNG	Damping State
DBAND	Deadband
DENIED	Incorrect Security Password Entered
DIAGS	Sensor Diagnostic State - On or Off, or Diagnostic Relay Output State
DISABL	Disable
DLY.MIN	Delay on Relay Output in Minutes
DSBL.RO	Disable Relay Outputs during Cleaning Cycle
DSP.SEC	Display Damping Value in Seconds
EDT.CAL	Edit Calibrate State
FACTRY	Factory State
FAIL.HI	Fail High (i.e., 20 mA)
FAIL.LO	Fail Low (i.e., 0 or 4 mA)
HI SPT	High Setpoint Value
HI.PV	High Process Variable Relay Output State
HI.PV.CT	High Process Variable Cycle Timer Relay Output State
HI.TMP.C	High Temperature in degrees Celsius Relay Output State

TEXT STRING	DESCRIPTION
HI.TMP.F	High Temperature in degrees Fahrenheit Relay Output State
HLD.LEV	Hold Level
HLD.ALL	Hold All Outputs State
HLD.AO	Hold Analog Outputs during Cleaning Cycle
HLD.AO1	Hold Analog Output One State
HLD.AO2	Hold Analog Output Two State
HLD.DO1	Hold Relay Output One State
HLD.DO2	Hold Relay Output Two State
HLD.DO3	Hold Relay Output Three State
HLD.RO	Hold Relay Outputs during Cleaning Cycle
HOLD	Hold State
INSTR.	Instrument Diagnostic Fault Conditions
K1/K25	Conductivity at temperature Point 1 to reference conductivity at 25°C. Points 2 through 6 represented in same manner.
LINEAR	Linear Analog Output One State
LO.TMP.C	Low Temperature in degrees Celsius Relay Output State
LO.TMP.F	Low Temperature in degrees Fahrenheit Relay Output State
LO SPT	Low Setpoint Value
LO.PV	Low Process Variable Relay Output State
LO.PV.CT	Low Process Variable Cycle Timer Relay Output State
LO.VAL	Low Calibration (Buffer or Standard) Value
MODIFY	Modify Configure State
NEUTRL	Neutral
NEW.VAL	New Calibration Value - The PV or Temperature value expected during a PV or Temperature Calibration.
NEW.VL.C	New Value in °C
NO D.P.	No Decimal Point
NO.ICON	No Icon Desired In Primary Display
NON.LIN	Non-Linear Output State
NONE	None

TEXT STRING	DESCRIPTION
OFFSET	Offset
ON.MIN	On Time for Cycle Timer Relay Output in Minutes, or On Time for Cleaner Relay Output in Minutes
OUTPUT	Output/Hold Mode
PASSWD	Security Password
PT 100	Pt100 Ohm RTD
PT 1000	Pt1000 Ohm RTD
PUR.H2O	Pure Water
PV	Process Variable
PV SLP	Process Variable Slope
PV OFF	Process Variable Offset
RCV.MIN	Recovery Time for Cleaner Relay Output in Minutes
REL.HLD	Release Hold
RELAY1	Relay Output One
RELAY2	Relay Output Two
RELAY3	Relay Output Three
RERANG	Rerange State
RESET?	Conduct a Reset Operation?
REV.A10	Software Revision A10
REL.HLD	Release Hold State
RESET?	Confirm Reset Operation?
RF.TMP.C	Reference Temperature in Celsius
RST.ALL	Reset All Parameters to Factory Settings
RST.CAL	Reset Calibration Constant and Data to Factory Settings
RST.CON	Reset Configurations to Factory Defaults
RST.SEC	Reset Security - Remove any existing security and reset the security password.
RST.SFT	Reset Software (i.e., Firmware).
SAF.MD.1	Safe Mode State for Analog Output One
SAF.MD.2	Safe Mode State for Analog Output Two
SAVE?	Save the Configuration?
SEC.DSP	Secondary Display Mode
SECS	Seconds

TEXT STRING	DESCRIPTION
SECUR	Security Mode
SENSOR	Sensor Diagnostic Faulty Conditions
SLF.TST	Self Test
SLOPE	Slope
SPIKE	Spike Output State
SPK.MAG	Spike Output Magnitude
SPK.OFF	Spike Output Function set to Off (i.e., Disable)
SPT.TUN	Setpoint/Tune Mode
STABL?	Is the displayed Process Variable Stable?
STATE	Relay State - On or OFF
T.OFF°C	Temperature Offset in °C
TC.COEF	Temperature Compensation Coefficient
TC.TYPE	Temperature Compensation Type State
TEMP°F	Temperature in degrees Fahrenheit
TMP.CAL	Temperature Calibrate State
TMP.OFF	Temperature Offset
TMP.SLP	Temperature Slope
TMP.SNS	Temperature Sensor Type State
TMP1°C	Temperature Independent Variable Value for Break Point One in degrees Celsius. Points Two through Six represented in same manner.
TEMP°C	Temperature in degrees Celsius
U.D.UNIT	User-Defined Engineering Unit
UNITS	Engineering Unit
USER	User State
USR.DEF	User-Defined Concentration or Temperature Compensation States
VIEW	View Configure State
X-1	Percent Input Independent Variable Value for Break Point One in percent of input range. Points Two through Six represented in same manner.
X1.COND	Conductivity Independent Variable Value for Break Point One in Conductivity Units. Points Two through Six represented in same manner.

---

<b>TEXT STRING</b>	<b>DESCRIPTION</b>
Y-1	Percent Output Dependent Variable Value for Break Point One in percent of output range. Points Two through Six represented in same manner.
Y1.CONC	Concentration Dependent Variable Value for Break Point One in Concentration Units. Points Two through Six represented in same manner.

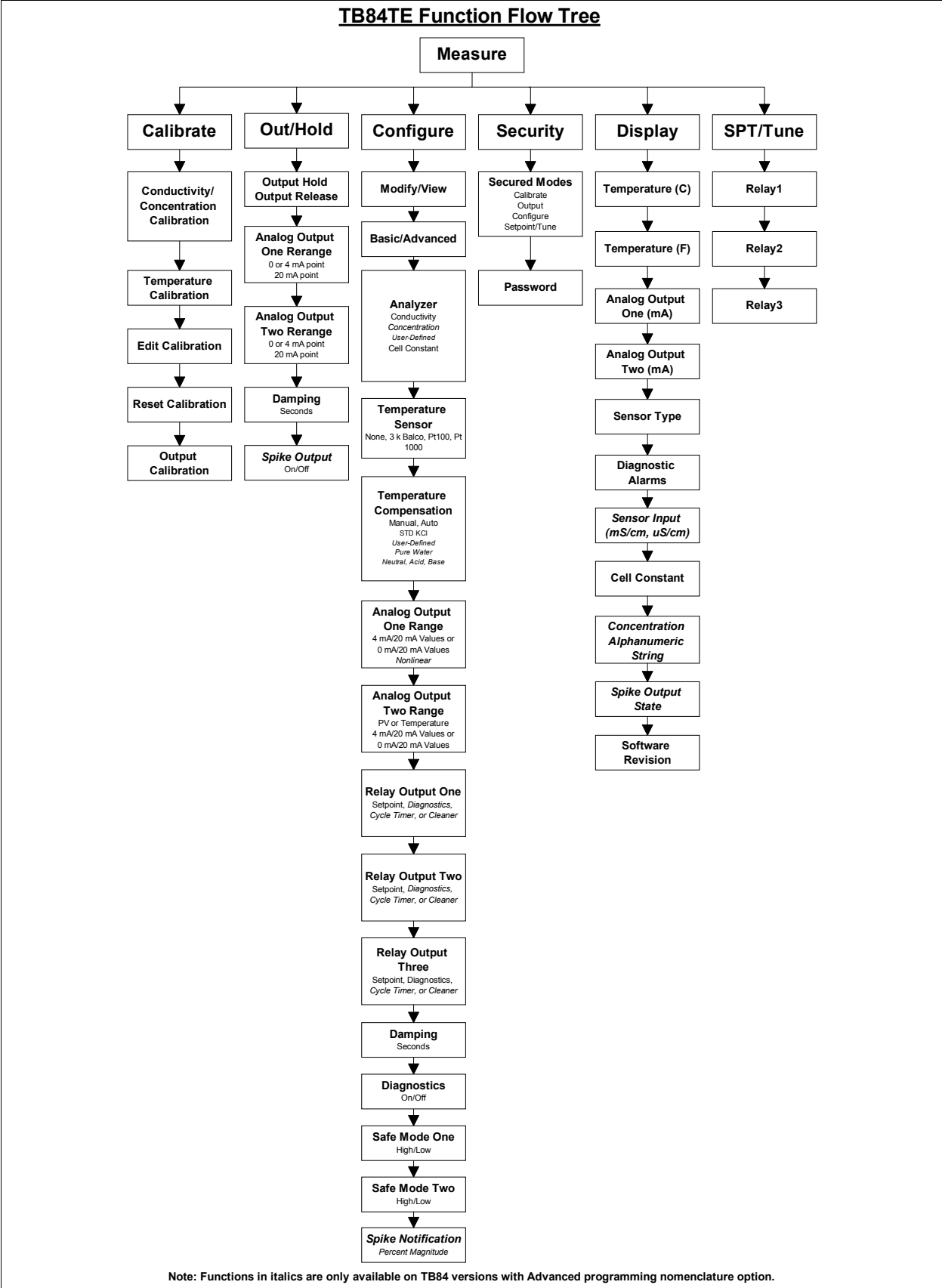

Figure C-1. TB84TE Programming Function Flow Chart.



---

**APPENDIX D - CONFIGURATION WORKSHEETS**

---











Form I-E67-84-3B Litho in U.S.A. March 2002  
Copyright © 2002 by ABB., as an Unpublished Work, All Rights Reserved  
® Registered Trademark of ABB.  
™ Trademark of ABB.

**ABB Inc.**  
9716 S. Virginia St., Ste.E  
Reno, Nevada 89511  
USA  
Tel: +1 (775) 850-4800  
FAX: +1 (775) 850-4808

**ABB Ltd**  
Oldends Lane, Stonehouse  
Gloucestershire, GL 10 3TA  
UK  
Tel: +44 (0) 1453-826661  
Fax: +44 (0) 1453-829671

**ABB Automation Products  
GmbH**  
Heerdter Landstr. 193  
D-40549 Düsseldorf  
Tel: +49 (211) 50077300  
Fax: +49 (211) 50077333

The Company's policy is one of continuous product improvement and the right is reserved to modify the information contained herein without notice.