

10ST1000 SWIRLMETER

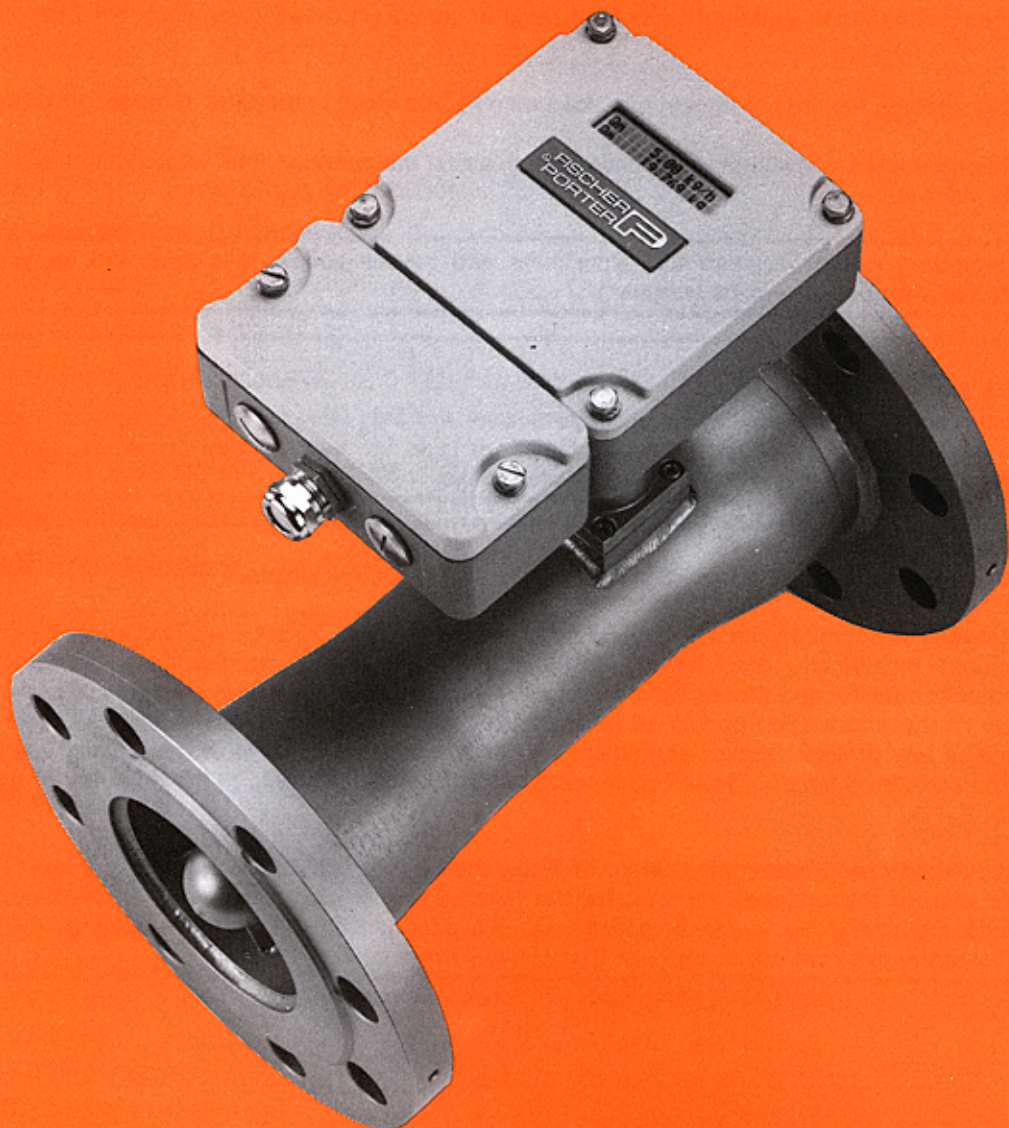

The following are registered trademarks of Du Pont:

TEFLON®
VITON®
KALREZ®

The following is a registered trademark of the HART Communication Foundation:

HART®

WARNING notices as used in this manual apply to hazards or unsafe practices which could result in personal injury or death.

CAUTION notices apply to hazards or unsafe practices which could result in property damage.

NOTES highlight procedures and contain information which assist the operator in understanding the information contained in this manual.

All software, including design, appearance, algorithms and source codes, is owned and copyrighted by Elsag Bailey Process Automation or its suppliers.

WARNING

POSSIBLE PROCESS UPSETS

Maintenance must be performed only by qualified personnel and only after securing equipment controlled by this product. Adjusting or removing this product while it is in the system may upset the process being controlled. Some process upsets may cause injury or damage.

NOTICE

The information contained in this document is subject to change without notice.

Elsag Bailey Process Automation, its affiliates, employees, and agents, and the authors of and contributors to this publication specifically disclaim all liabilities and warranties, express and implied (including warranties of merchantability and fitness for a particular purpose), for the accuracy, currency, completeness, and/or reliability of the information contained herein and/or for the fitness for any particular use and/or for the performance of any material and/or equipment selected in whole or part with the user of/or in reliance upon information contained herein. Selection of materials and/or equipment is at the sole risk of the user of this publication.

This document contains proprietary information of Elsag Bailey Process Automation, and is issued in strict confidence. Its use, or reproduction for use, for the reverse engineering, development or manufacture of hardware or software described herein is prohibited. No part of this document may be photocopied or reproduced without the prior written consent of Elsag Bailey Process Automation.

**ADDENDUM TO
VORTEX / SWIRL FLOWMETER
INSTRUCTION BULLETINS**

This addendum modifies information contained in the following Vortex & Swirlmeter Instruction Bulletins:

10VT1000	PN24795
10VR1000	PN24796
10ST1000	PN24793
10SR1000	PN24794

The purpose of this addendum is to revise the **NOTE** statement in **Section 4.3.16 Range Minimum (Q_{min})** of Chapter 4.0 - Start-Up and Operation in the Instruction Bulletins referenced above.

The statement has been revised to read as follows:

NOTE
If Mass Flow or Standard Flow is selected as the flow mode in Section 4.3.8, the units of Range Min. will continue to be displayed in the volumetric flow units selected in Section 4.3.12.

This information replaces the corresponding information presently given in the above Instruction Bulletins. All other Instruction Bulletin parameters remain unchanged.

**CONVERSION INSTRUCTIONS
3-WIRE SENSOR TO 2-WIRE CONFIGURATION**

The purpose of this addendum is to provide information for converting three-wire Vortex and Swirlmeter sensors to two-wire configuration where applicable. Newer models of Vortex (Models 10VT) and Swirlmeters (Models 10ST) have terminal blocks that have been designed for use with 3-wire sensors. Models 10VM & 10VR and 10SM & 10SR continue to use 2-wire input terminal blocks and use the 3-wire sensor configured to a 2-wire mode as shown in the illustration below.

The 2-wire sensor configuration is also required when retrofitting older Vortex 10VT and Swirlmeter 10ST models with the new 3-wire sensors since the older models contain 2-wire terminal blocks on the circuit board.

3-WIRE SENSOR PART NUMBERS

B-F&P PART NUMBER	METER SIZE	GASKET TYPE	MATERIAL	LENGTH
D693B027U01 D693B027U09 D693B027U11 D693B027U03	1/2 - 6 inch (DN15 - DN150)	Flat O-Ring O-Ring Flat	Steel 1.4571 " " Hastelloy C	Standard
D693B029U01 D693B029U09 D693B029U11 D693B029U03	≥ 8 inch (≥ DN200)	Flat O-Ring O-Ring Flat	Steel 1.4571 " " Hastelloy C	Long

The sensors listed above have three wires:

- one **blue** lead
- one **red** lead
- one **yellow** lead

To convert the sensors to 2-wire mode:

- twist **yellow & red** wires together
- connect **yellow/red** wires to terminal 19 on the PCB terminal block
- connect **blue** wire to terminal 2B on the PCB terminal block

Refer to the generic cutaway diagram shown on the right for dressing and connection of the sensor leads. The diagram shows the newer "tower assembly" construction. Older "tower assemblies" will have different construction from that shown.

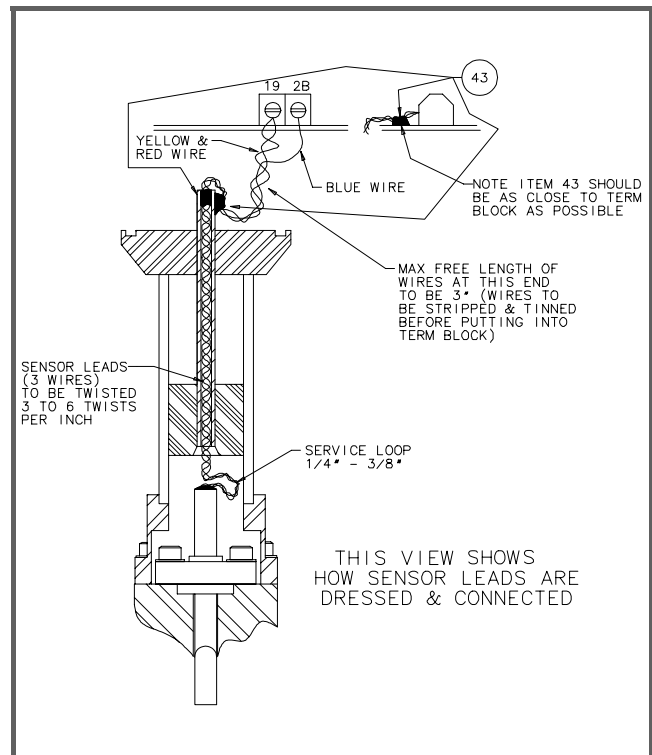

Table of Contents

SAFETY SUMMARY	I
READ FIRST	II
1.0 INTRODUCTION	1-1
1.1 Description	1-1
1.1.1 Principle of Operation	1-1
1.2 Back Pressure Requirements for Liquid Flow	1-2
1.3 Model Number Breakdown	1-3
1.4 Specifications	1-6
2.0 INSTALLATION	2-1
2.1 Inspection	2-1
2.2 Location and Mounting	2-1
2.2.1 Extreme Temperature Applications	2-1
2.3 Temperature/Pressure Monitoring	2-2
2.4 Meter Weights	2-2
2.5 Flanged Meter Installation	2-4
2.6 Electrical Interconnections	2-5
2.7 Conduit Seal and Pressure Relief	2-7
3.0 DATA ENTRY AND CONFIGURATION	3-1
3.1 Pushbuttons and Display	3-1
3.2 Pushbutton Functions	3-1
3.3 Instructions for Entering Data Into the Converter	3-3
3.4 Parameter Summary and Data Entry	3-4
4.0 START-UP AND OPERATION	4-1
4.1 Start-Up	4-1
4.2 Error Messages	4-1
4.3 Menu Display and Selections	4-1
4.3.1 Firmware Version	4-2
4.3.2 Program Protection	4-2
4.3.3 Language	4-4
4.3.4 Primary	4-4
4.3.5 Fluid	4-4
4.3.6 Meter Size	4-4
4.3.7 Median k-factor	4-5
4.3.8 Flow Mode	4-5
4.3.9 Compressibility	4-5
4.3.10 Unit Density	4-6
4.3.11 Actual Density	4-6
4.3.12 Unit Qv (volumetric)	4-6

4.3.13 Unit Qm (mass flow)	4-7
4.3.14 Meter Range Maximum	4-7
4.3.15 Range Maximum	4-7
4.3.16 Range Minimum	4-8
4.3.16.1 Current Output vs. Range Min. Setting	4-8
4.3.17 Sub Menu Totalizer	4-9
4.3.17.1 Unit Totalizer	4-9
4.3.17.2 Totalizer	4-9
4.3.17.3 Overflow	4-9
4.3.17.4 Function Totalizer Reset	4-10
4.3.18 Sub Menu Pulse Output	4-10
4.3.19 Damping	4-10
4.3.20 Sub Menu Current Output	4-10
4.3.20.1 Current	4-10
4.3.20.2 I _{out} at Alarm	4-10
4.3.21 Sub Menu Display	4-11
4.3.21.1 Display 1. line	4-11
4.3.21.2 Display 2. line	4-11
4.3.22 Sub Menu Self Check	4-12
4.3.23 Sub Menu Error Register	4-13
4.3.23.1 Error Register	4-13
4.3.23.2 Mains Interrupt	4-13
4.3.24 Code Number (Calibration Parameters)	4-13
4.3.24.1 Instrument Number	4-14
4.3.24.2 Sub Menu k-factor	4-14
4.3.24.2.1 k-Factor linearization	4-15
4.3.24.2.2 Median k-factor	4-15
4.3.24.3 Selectable Meter Range Maximum	4-16
4.3.24.4 Function Reset Error	4-16
4.3.24.5 Function Initialize EEPROM	4-16
4.3.24.6 Function Adjust I _{out} 4 mA	4-17
4.3.24.7 Function Adjust I _{out} 20 mA	4-17
4.3.24.8 Function Minimum Current	4-17
4.3.24.9 Error Code 9	4-17
4.4 Analog Board Switches	4-18
5.0 TROUBLESHOOTING AND FLOW RATE TABLES	5-1
5.1 Troubleshooting	5-1
5.2 Flow Rates and Frequencies	5-3
6.0 PARTS LIST	6-1

SAFETY SUMMARY

GENERAL WARNINGS

POSSIBLE PROCESS UPSETS

Maintenance must be performed only by qualified personnel and only after securing equipment controlled by this product. Adjusting or removing this product while it is in the system may upset the process being controlled. Some process upsets may cause injury or damage.

RETURN OF EQUIPMENT

All Flowmeters and/or Signal Converters being returned to Bailey-Fischer & Porter for repair must be free of any hazardous materials (acids, alkalis, solvents, etc.). A Material Safety Data Sheet (MSDS) for all process liquids must accompany returned equipment. Contact Bailey-Fischer & Porter for authorization prior to returning equipment.

INSTRUCTION MANUALS

Do not install, maintain or operate this equipment without reading, understanding and following the proper Bailey-Fischer & Porter instructions and manuals, otherwise injury or damage may result.

SPECIFIC WARNINGS

When the meter is used in a very high or low temperature process, the temperature of the meter body may be extremely hot or cold. If it is necessary to touch the sensor housing or meter body, insulated gloves must be worn to prevent serious injury. (pg. 2-1)

All Flowmeters and/or Signal Converters being returned to Bailey-Fischer & Porter for repair must be free of any hazardous materials (acids, alkalis, solvents, etc.). A Material Safety Data Sheet (MSDS) for all process liquids must accompany returned equipment. Contact Bailey-Fischer & Porter for authorization prior to returning equipment. (pg. II, 5-1)

SPECIFIC CAUTIONS

The pipeline and meter body may be insulated by the user. However, the meter interconnection wiring box and the sensor housing tower must not be insulated. Ambient air is required to dissipate heat or cold build-up within the interconnection wiring box. (pg. 2-1)

All unused conduit entrances must have pipe plugs installed. This is required to maintain the NEMA 4X enclosure rating. (pg. 2-9)

READ FIRST

This Instruction Bulletin contains the following changes from the previous A.42 Firmware issue (PN24739):

- Changed .75 in. min. flow data in Tables 1-1, 1-3, 1-5 & 1-6
- Changed sensor material from 321 SS to 316 SS (German sensor)
- Revision of "K-Factor Correction" information in Section 1.4
- Maximum Range Max. entry reduced from 130% of Meter Range Max. to 115%
- Addition of "Standard Flow" mode to flow menu & display
- "Init. K-Factor", "HART-Enable" & "Totalizer Set " menus removed
- "HART Transmitter" , "HART Command" & "Test Fout" tests moved into "Self Check" sub-menu
- HART-Protocol "Special Commands" expanded
- Added Chapter 3.0 - Data Entry and Configuration
- Revised Table 4-3 - Analog Board Filter Switch Settings

WARNING

INSTRUCTION MANUALS

Do not install, maintain, or operate this equipment without reading, understanding and following the proper Bailey-Fischer & Porter instructions and manuals, otherwise injury or damage may result.

RETURN OF EQUIPMENT

All Flowmeters and/or Signal Converters being returned to Bailey-Fischer & Porter for repair must be free of any hazardous materials (acids, alkalis, solvents, etc). A Material Safety Data Sheet (MSDS) for all process liquids must accompany returned equipment. Contact Bailey-Fischer & Porter for authorization prior to returning equipment.

NEMA 4X, Corrosion Resistant Finish

This product is painted with a high performance epoxy paint. The corrosion protection provided by this finish is only effective if the finish is unbroken. It is the users' responsibility to "touch-up" any damage that has occurred to the finish during shipping or installation of the product. Special attention must be given to: meter flange bolting, pipe mounting of electronics, conduit entries and covers that are removed to facilitate installation or repair. For continued corrosion protection throughout the product life, it is the users' responsibility to maintain the product finish. Incidental scratches and other finish damage must be repaired and promptly re-painted with approved touch-up paint. Provide the model number and size of your product to the nearest Bailey-Fischer & Porter representative to obtain the correct touch-up paint.

Read these instructions before starting installation;
save these instructions for future reference.

1.0 INTRODUCTION

1.1 Description

The Bailey-Fischer & Porter 10ST1000 Swirlmeter is supplied with an integrally mounted microprocessor-based signal converter. This combination of flowmeter and electronics allows maximum flexibility for on-site calibration and maintenance. The three button keypad allows database interrogations and changes at the Flowmeter. The two line, 16 character LCD display permits continuous monitoring of the flow rate and totalizer.

The flowmeter is suitable for service with gas and liquid processes. The meter's extended temperature range permits accurate metering of saturated and superheated steam.

The meter body and process connections are made from 316L stainless steel. The sensor is made from 316 stainless steel. Because the meter has no moving parts, routine maintenance or recalibration is not required.

The 10ST1000 Swirlmeter is FM (Factory Mutual Research) approved as: Intrinsically Safe for Classes I, II and III, Division 1, Groups A, B, C, D, E, F and G, ENTITY; per ID-10-1104; Dust-ignitionproof for Class II Division 1, Groups E, F and G; Suitable for Class III Division 1; Nonincendive for Class I, Division 2, Groups A, B, C and D; for outdoor Hazardous (Classified) Locations; NEMA 4X.

1.1.1 Principle of Operation

The Swirlmeter body contains stationary swirler blades at the meter inlet. The design of these blades forces the axial flow of the fluid into a rotational movement. Due to this "swirling" of the fluid, a vortex is generated at the center of the rotation and forced by a backflow into a secondary rotation whose frequency is proportional to the flow rate. The generation of the vortex is shown pictorially in Figure 1-1. The generated frequency is linear over a wide flow range due to the optimized internal geometry of the instrument and is measured using a piezoelectric sensor. The sensor's frequency signal is converted by the Converter electronics into a 4 - 20mA DC output current

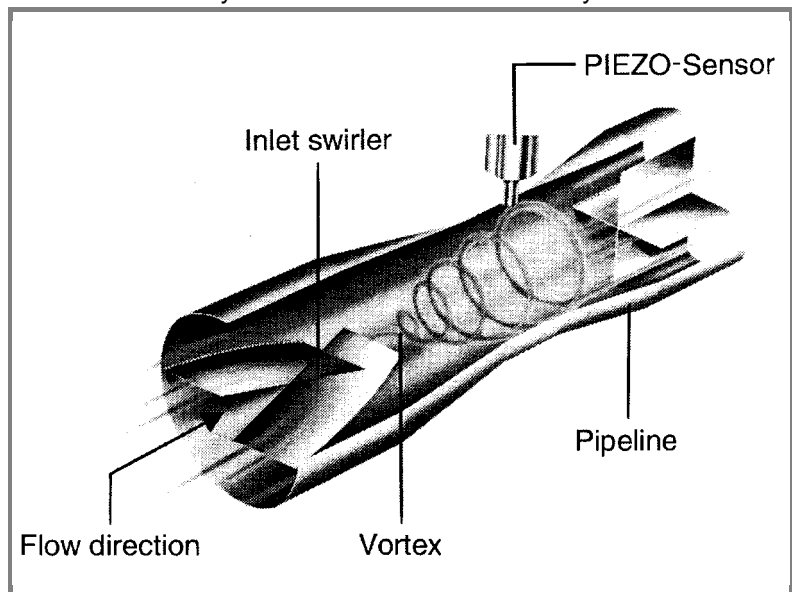

FIGURE 1-1. SWIRLMETER VORTEX GENERATION

Figure 1-2, below, shows diagrammatically the operating principle of the Swirlmeter with the vortex action formed by the generated backflow.

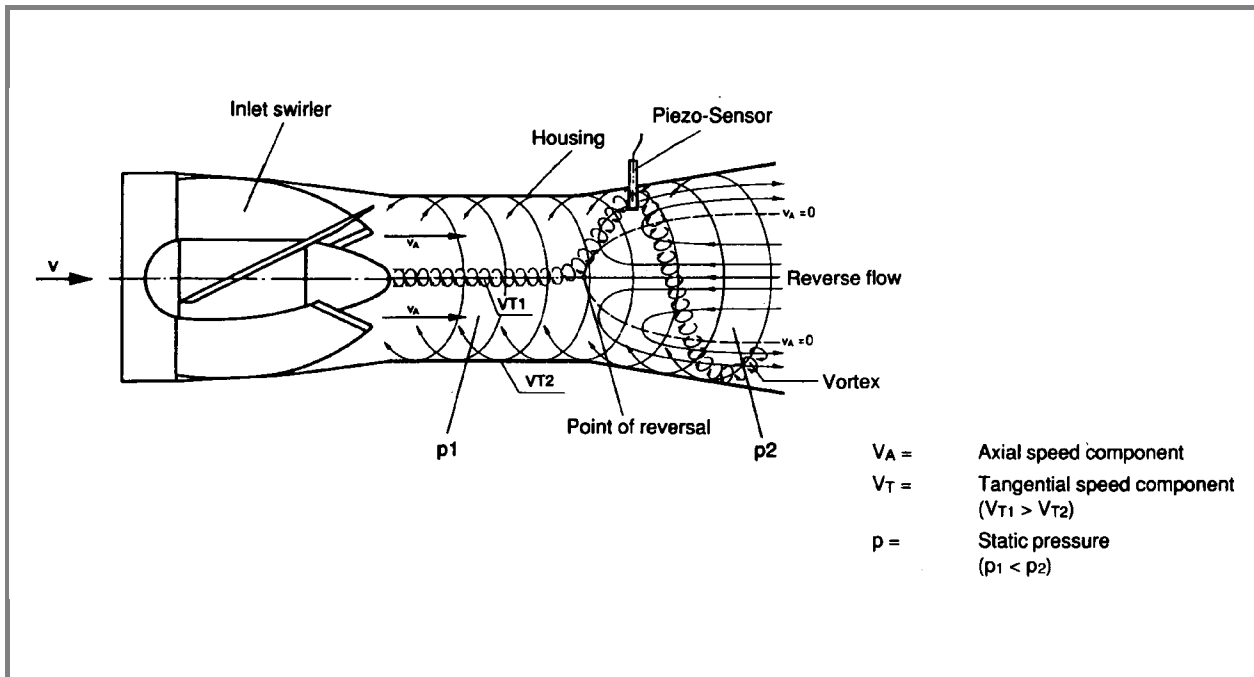

FIGURE 1-2 SWIRLMETER OPERATING PRINCIPLE

1.2 Back Pressure Requirements for Liquid Flow

In order to prevent cavitation in the meter it is necessary to maintain a minimum back pressure in the system. The required back pressure is determined using the following formula:

$$P_b \geq 1.3P_v + 2.6\Delta P$$

where:

P_b = minimum required back pressure (psig)

P_v = vapor pressure of the fluid at specified conditions (psig)

ΔP = pressure drop (psig)

1.3 Model Number Breakdown

Refer to the Bailey-Fischer & Porter data sheet or the data tag on the equipment for the model number of the instrument furnished. The details of a specific number are shown on the following two pages:

1.3 Model Number Breakdown (cont.)

	10ST	1	1	—	B	—	—	9	A	—	A	2	A	A	—	A
<u>Engineering Reference</u> Integral Swirlmeter																
<u>Design Designation</u> Fixed Data																
<u>Materials of Construction</u> Body/Sensor 316L/316 Stainless Steel			1													
<u>Fluid Type</u>																
Liquid					01											
Gas					02											
Natural Gas					03											
Saturated Steam					04											
Superheated Steam					05											
Oxygen					06											
Other					99											
<u>Design Level</u>						B										
<u>Meter Sizes</u>																
.75 in. (DN20)							B									
1 in. (DN25)							C									
1.25 in. (DN32)							D									
2 in. (DN50)							E									
3 in. (DN80)							F									
4 in. (DN100)							G									
6 in. (DN150)							H									
8 in. (DN200)							I									
12 in. (DN300)							K									
16 in. (DN400)							L									
<u>Pressure Rating</u>																
ANSI Class 150 (PN10)								P								
ANSI Class 300 (PN16)								Q								
<u>Safety Approvals</u>																
Intrinsically Safe for Classes I, II & III, Div.1, Groups A thru G, ENTITY;									9							
Dust-ignitionproof for Class II Div.1, Groups E,F & G; Suitable for																
Class III, Div.1; Nonincendive for Class I, Div.2, Groups A,B, C & D;																
for outdoor Hazardous (Classified) Locations; NEMA 4X.																

1.3 Model Number Breakdown (cont.)

	10ST	1	1	—	B	—	—	1	A	—	A	2	A	A	—	A	
Sensor																	
Fixed Data																A	
Sensor Seal Material																	
Kalrez																3	
Viton																4	
Teflon (-20 to 230°C / -4 to 446°F)																5	
Other																9	
Calibration																	
															A		
Language																	
English																2	
Software Level																	
															A		
Operating Mode																	
Continuous Flow																A	
Options																	
None																0	
HART Protocol																1	
Power Supply																	
14 - 46 VDC																A	

1.4 Specifications

Fluid Types

Gas, liquid or steam

Sizes (Available in Flanged Version Only)

inches	mm
.75	20
1	25
1.25	32
2	50
3	80
4	100
6	150
8	200
12	300
16	400

Accuracy

± 0.5% of rate

Rangeability

Typically 25 to 1. Refer to Tables 1-1 through 1-6.

Process Pressure Limits

Rated for ANSI Class 150 or 300 (DIN PN 10-16) service, 275/720 psig (1.91/4.96 MPa)

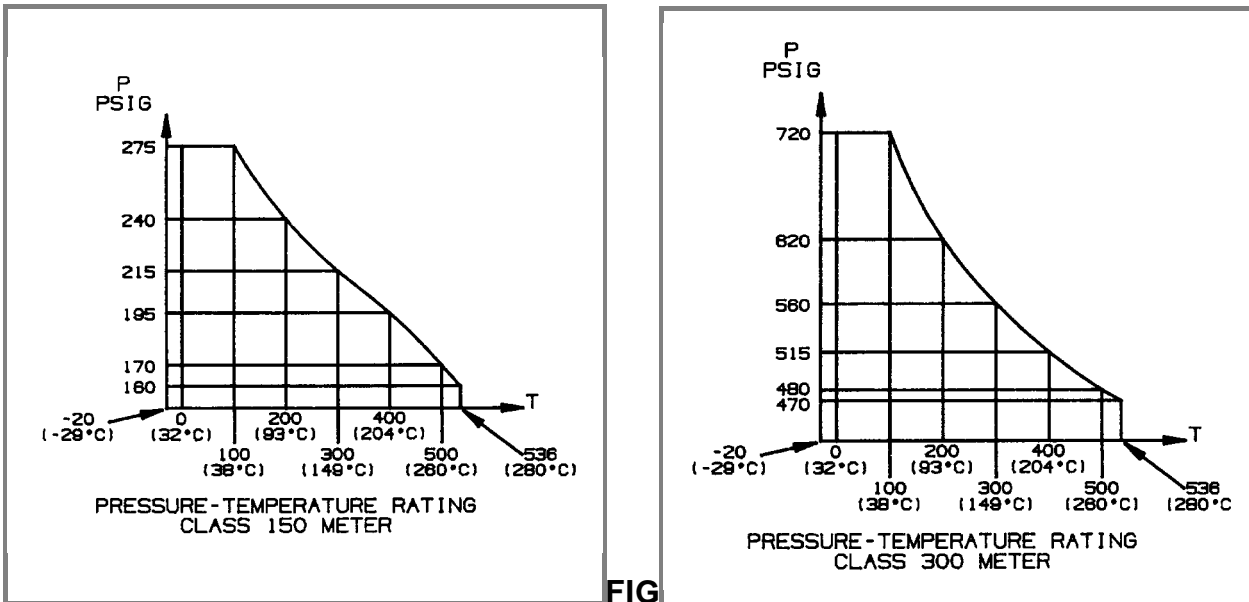

FIGURE 1-3 PROCESS PRESSURE vs. TEMPERATURE

Process Temperature Limits

-40 to 536° F (-40 to 280° C)

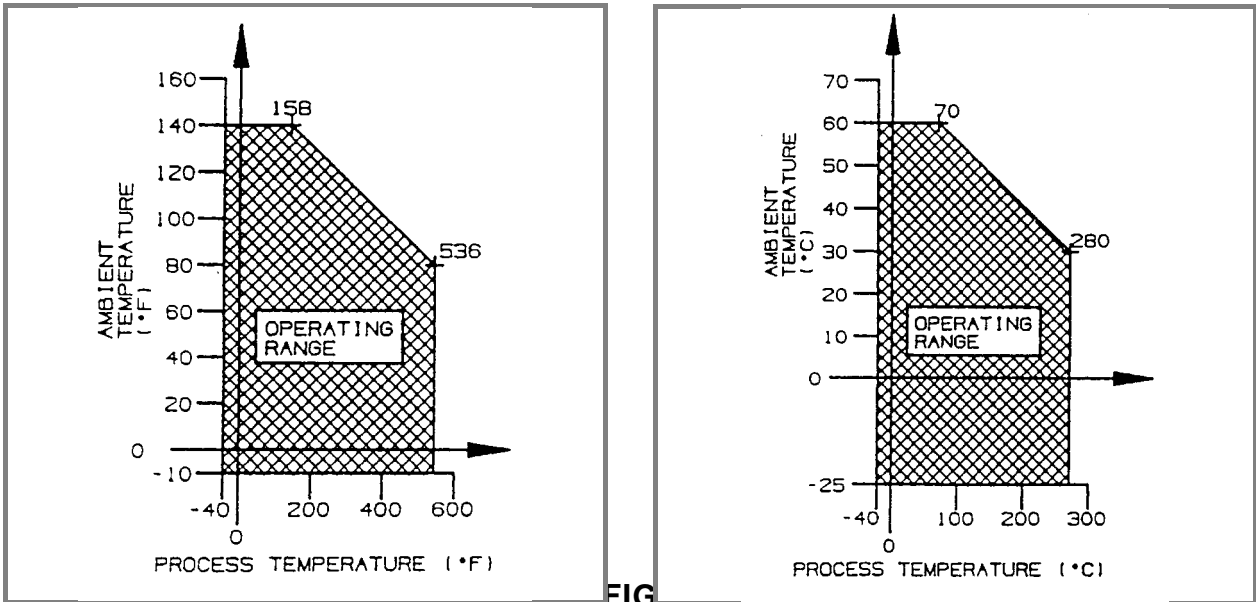

FIGURE 1-4 PROCESS OPERATING TEMPERATURES

Ambient Temperature Limits

-10 to 140° F (-25 to 60° C)

Maximum Vibration Limits

Air: 0.15g at 0 - 130 Hz
Water: 0.3g at 0 - 130 Hz

Relative Humidity Limits

5 - 95% non-condensing

Materials of Construction:

Signal Converter Housing

Diecast aluminum with epoxy paint
NEMA 4X (IEC 529 IP65)

Body

316L SST

Sensor

316 SST

Sensor Seal Material

KALREZ

VITON

TEFLON (-20 to 230°C / -4 to 446°F)

Certifications

Refer to Model Number Breakdown in Sub-Section 1.3.

Power requirements

14 - 46 V dc

Outputs

4 - 20 mA dc, 2 wire

Display

2 line, 16 character LCD standard

Output Load Resistance

The chart to the right shows the maximum allowable load resistance for a given power supply voltage.

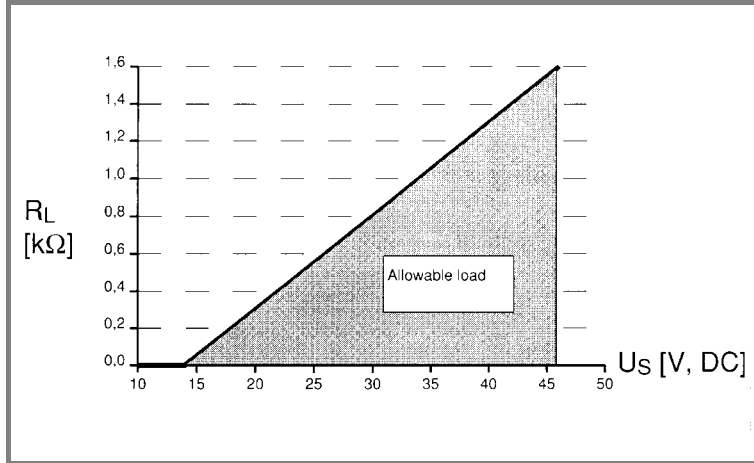

FIGURE 1-5. LOAD RESISTANCE vs. POWER SUPPLY VOLTAGE

Communications

Optional HART Protocol communication link superimposed on standard 2 wire 4 - 20 mA process signal.

The HART Protocol provides for digital communications between a process control system PC or a hand held terminal and the Swirlmeter. All values, such as input parameters, can be downloaded to the process control system or PC. In reverse, programming of a new configuration can be accomplished in a similar manner. The digital communication occurs through the use of an alternating signal superimposed on the current output (4-20 mA) which does not affect any of the other instruments connected to the output signal.

Transmission Type: Frequency Shift Keying (FSK) modulation on the 4-20 mA current output in accordance with the Bell 202 standard. Maximum signal amplitude 1.4V p-p.

Logic 1: 1200 Hz (no pulse)
 Logic 0: 2200 Hz (pulse)

Current Output Load: 250 Ω minimum,
 750 Ω maximum

Maximum cable length: 4920 ft (1500 m) using 22 AWG interconnect wiring

Baud rate: 1200

Mounting

A minimum straight pipe run must be maintained up and downstream of the meter for various piping configurations. Refer to Figure 1-6 for minimum straight pipe run requirements. The Swirlmeter can be installed at any attitude.

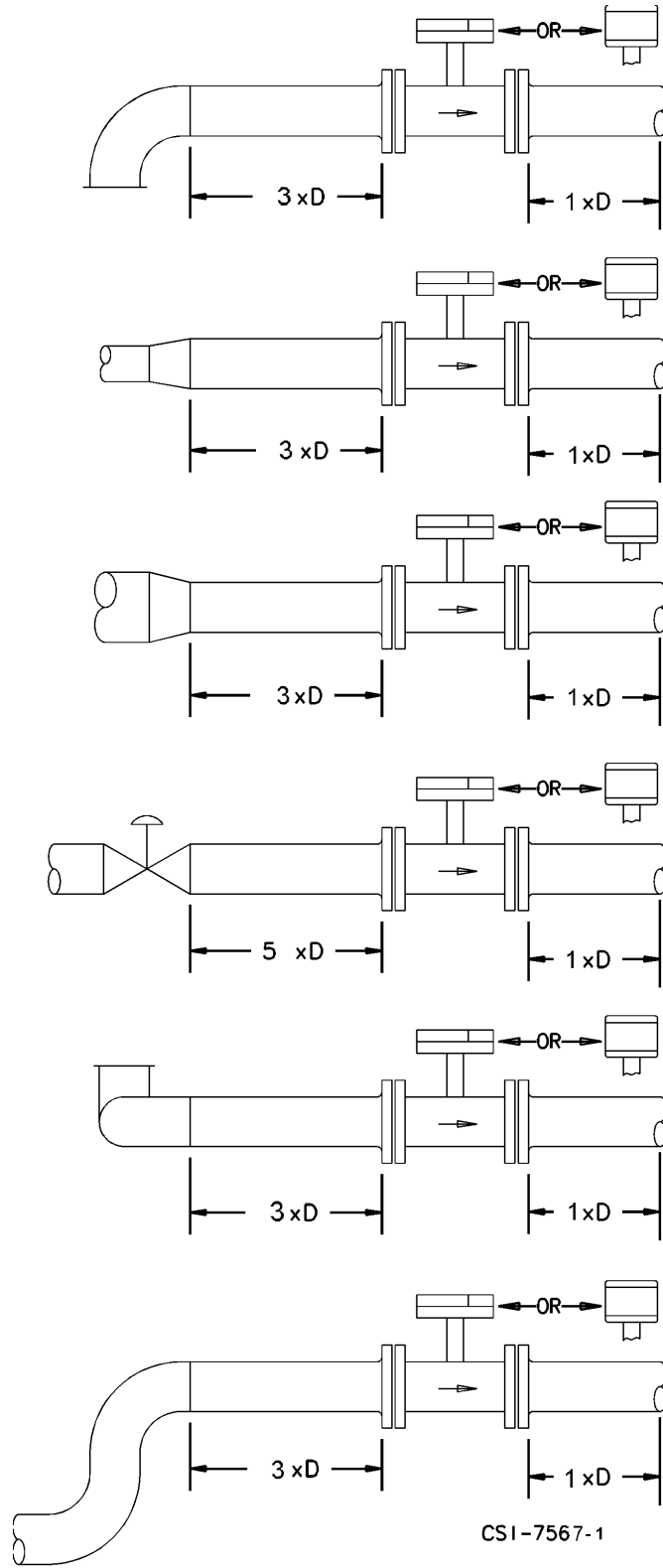

D = Meter Size

FIGURE 1-6. METER PIPING REQUIREMENTS

TABLE 1-1. AIR FLOW RATES

Meter Size		Minimum Air Flow	Maximum Air Flow			
inches	mm	acfh	acfh	min ft/sec	Frequency @ Max. flow (Hz)	max Δ p (psi)
.75	20	177	883	15	1200	0.4
1	25	177	1766	10	1200	0.5
1.25	32	248	4591	15	1200	1.05
2	50	636	12360	8.2	1200	1.3
3	80	1410	30018	7.2	680	1.03
4	100	2295	52973	7.5	670	1.35
6	150	4237	127132	6.2	470	1.4
8	200	7063	176575	5.6	280	1.25
12	300	14126	353150	4.9	160	1.3
16	400	35315	706300	7.2	150	1.3

TABLE 1-2. GAS PRESSURE LOSS CALCULATIONS

Pressure Loss For Steam and Gas
$\Delta p_2 = \Delta p_1 \frac{\rho}{.0749} \left(\frac{Q}{Q_{max}} \right)^2$
Δp ₂ = Pressure drop at operating conditions
Δp ₁ = Max. pressure drop for air from Table 1-1
ρ = Operating density (lbs/ft ³)
Q = Operating flow rate (acfh)
Q _{max} = Maximum air flow rate (acfh) from Table 1-1

Conversions: psi x 6.895 = kPa

TABLE 1- 3. WATER FLOW RATES

Water Flow Rates at Standard Conditions @ 70°F (21°C)					
Meter Size		Flow Rate Limits (GPM)		Frequency @ Max. Flow	max Δp @ Max. Flow
inches	mm	Minimum	Maximum	Hz	psi
.75	20	2	9	100	3.6
1	25	2	27	135	4.3
1.25	32	4	44	107	3.6
2	50	11	110	90	3.6
3	80	15	440	78	7.2
4	100	22	660	77	6.5
6	150	66	1629	50	5.8
8	200	110	2200	30	7.2
12	300	440	4403	16	8
16	400	793	7925	13	8

NOTE: At Standard conditions at 70° F (21° C)

TABLE 1-4. LIQUID PRESSURE LOSS CALCULATIONS

Pressure Loss For Liquid Flow	
$\Delta p_2 = \Delta p_1 (\text{Sp. gr.}) \left(\frac{Q}{Q_{\max}} \right)^2$	
Δp ₂ = Pressure drop at operating conditions	
Δp ₁ = Max. pressure drop for water from Table 1-3	
Sp. gr. = Specific gravity at operating conditions	
Q = Operating flow rate (GPM)	
Q _{max} = Maximum meter water rate from Table 1-3	

Conversions: GPM x 0.22715 = m³/h
psi x 6.895 = kPa

See pg. 5-3 for additional conversion factors.

TABLE 1-5. AIR FLOW RATES AT SELECTED PRESSURES

METER SIZE in. (mm)	AIR FLOW	AIR FLOW RATES IN SCFH						
		PRESSURE (psig)						
		0	25	50	100	150	200	300
.75 (20)	min.	177	291	371	496	592	676	819
	max.	883	2385	3886	6890	9893	12897	18903
1 (25)	min.	177	291	371	496	592	676	819
	max.	1766	4769	7773	13780	19786	25793	37807
1.25 (32)	min.	248	408	520	696	830	948	1147
	max.	4591	12399	20207	35822	51438	67054	98285
2 (50)	min.	636	1046	1334	1784	2128	2430	2942
	max.	12360	33380	54401	96442	138482	180523	264605
3 (80)	min.	1410	2319	2957	3954	4718	5387	6522
	max.	30018	81069	132120	234222	336324	438426	642630
4 (100)	min.	2295	3775	4813	6436	7680	8768	10616
	max.	52973	143063	233153	413334	593514	773694	1134055
6 (150)	min.	4237	6969	8886	11883	14178	16188	19599
	max.	127132	343343	559554	991976	1424397	1856819	2721663
8 (200)	min.	7064	11618	14813	19808	23635	26985	32671
	max.	176575	476873	777170	1377765	1978361	2578956	3780146
12 (300)	min.	14129	23235	29626	39617	47270	53970	65341
	max.	353150	953745	1554340	2755531	3956721	5157912	7560293
16 (400)	min.	35322	58088	74066	99042	118174	134926	163354
	max.	706300	1907490	3108681	5511062	7913443	10315824	15120586

For gases with densities other than air:

$$SCFH = ACFH \cdot \left(\frac{P}{14.7}\right) \cdot \left(\frac{530}{460 + ^\circ F}\right)$$

$$Q_{\min} = ACFH_{\min} (.0749/\rho)^{1/2}$$

$$Q_{\max} = ACFH_{\max} \cdot \left(\frac{P}{14.7}\right) \cdot \left(\frac{530}{460 + ^\circ F}\right)$$

where P = Operating pressure (psia)
 $ACFH_{\min}$ = Refer to Table 1-1
 $ACFH_{\max}$ = Refer to Table 1-1
 ρ = Density of fluid at operating conditions (lbs/ft³)
 .0749 = Density of air @ 14.7 psia & 70° F

2.0 INSTALLATION

2.1 Inspection

All equipment should be inspected for damage that may have occurred during shipment. All damage should be reported to the shipping agent. If the equipment is damaged to the extent that faulty operation may result, contact Bailey-Fischer & Porter before installation. Always reference the complete instrument serial number and model number in all correspondence concerning the equipment supplied.

2.2 Location and Mounting

The meter can be installed at any angle and is available in a flange style body that mounts between adjacent pipe flanges of the process piping. Since the meter is unidirectional, it must be oriented in accordance with the direction of the process flow. A flow direction arrow is provided on the meter body to assure correct orientation.

Strainers and flow straighteners are not required. Refer to Figure 1-6 for meter piping requirements.

Assuming a properly supported pipeline, vibration problems should not be encountered in normal industrial applications.

In vertical and sloping installations, the electrical conduit entries should face downward to retard the entry of condensation. In horizontal installations, when process temperatures above 160° F (71° C) or below 0° F (-18° C) are encountered, the meter must be oriented so that the junction box is located to the side of the meter body, not above or below.

CAUTION

The pipeline and meter body may be insulated by the user. However, the meter interconnection wiring box and sensor housing tower must not be insulated. Ambient air is required to dissipate heat or cold build-up within the interconnection wiring box.

The meter includes a pressure relief feature described in Sub-Section 2.7. Take the location of this pressure relief into consideration when locating and orienting your meter.

2.2.1 Extreme Temperature Applications

For process temperatures above 160° F (71° C) or below 0° F (-18° C), it is critical that the meter be pressurized and placed into service gradually, i.e., with sufficient time delay to minimize thermal shock. Steam should be introduced gradually so that the meter is brought up to operating temperature over a ten to fifteen minute period.

WARNING

When the meter is used in a very high or low temperature process, the temperature of the meter body may be extremely hot or cold. If it is necessary to touch the sensor housing or meter body, insulated gloves must be worn to prevent serious injury.

2.3 Temperature/Pressure Monitoring

Provisions for temperature and/or pressure monitoring are the responsibility of the user. The temperature sensor should be located approximately three pipe diameters downstream of the flowmeter. Measurement is from the downstream face of the meter. The pressure tap is located in the Swirlmeter body as shown in Fig. 2-1. Measurement is from the downstream face of the meter.

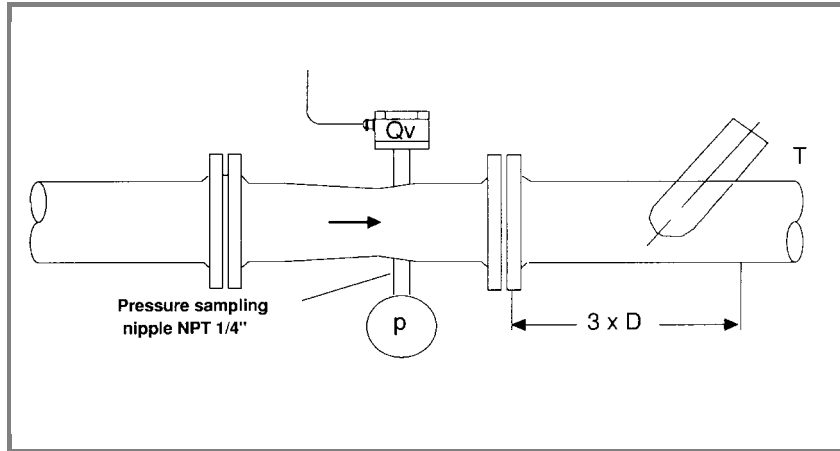

FIGURE 2-1. PRESSURE AND TEMPERATURE MEASUREMENT LOCATIONS

2.4 Meter Weights

The weights shown in the following table are approximate and should only be used as a guide when installing the meter.

TABLE 2-1. SWIRLMETER WEIGHTS

Meter Size		Flange Class 150 lbs (kg)	Flange Class 300 lbs (kg)
inch	mm		
.75	20	4.7 (2.1)	6.6 (3.0)
1	25	7.9 (3.6)	9.7 (4.4)
1.25	32	8.2 (3.7)	11.9 (5.4)
2	50	15.7 (7.1)	21.6 (9.8)
3	80	25.8 (11.7)	35.7 (16.2)
4	100	40.8 (18.5)	60.6 (27.5)
6	150	66.3 (30.1)	101.5 (46.0)
8	200	99.5 (45.1)	165.5 (75.1)
12	300	401 (182)	-
16	400	574 (260)	-

Refer to Figure 2-2 for outline dimensions of the flowmeter.

10ST1000 SWIRLMETER INSTRUCTION BULLETIN

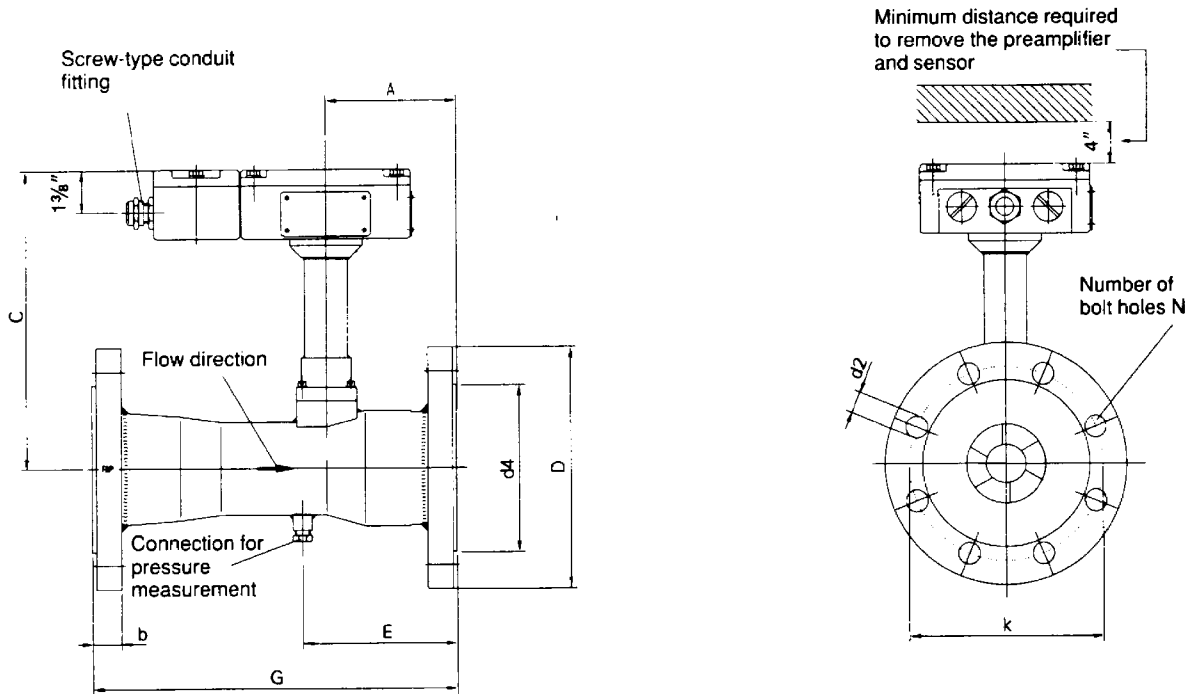

OUTLINE DIMENSIONS Inches (mm)

SIZE	ANSI RATING	A	C	E	G	D	b	K	d2	d4	N
3/4 (20)	150	2	8-3/4	2-3/8	4-3/4	3-7/8 (98.6)	1/2 (12.7)	2-3/4 (62.5)	5/8 (15.7)	1-11/16 (42.9)	4
	300	(52)	(221)	(60)	(120)	4-5/8 (117)	5/8 (15.7)	3-1/4 (82.5)	3/4 (19)	1-11/16 (42.5)	
1 (25)	150	2-3/16	8-3/4	2-1/2	6"	4-1/4 (107.9)	1/2 (14.3)	3-1/8 (79.4)	5/8 (15.9)	2 (50.8)	4
	300	(55)	(221)	(62.5)	(150)	4-7/8 (123.8)	5/8 (17.5)	3-1/2 (88.9)	3/4 (19)	2 (50.8)	
1-1/4 (32)	150	2-3/16	8-7/8	2-1/2	6	4-5/8 (117.5)	5/8 (15.3)	3-1/2 (88.9)	5/8 (15.9)	2-1/2 (63.4)	4
	300	(55)	(225)	(65)	(150)	5-1/4 (133.3)	3/4 (19)	3-7/8 (96.4)	3/4 (19)	2-1/2 (63.4)	
2 (50)	150	2-3/4	9	3-11/32	8	6 (152)	3/4 (19)	4-3/4 (121)	3/4 (19)	3-5/8 (92.1)	4
	300	(71)	(230)	(85)	(200)	6-1/2 (165.1)	7/8 (22.2)	5 (127)	3/4 (19)	3-5/8 (92.1)	8
3 (80)	150	4-1/8	9-3/8	5	12	7-1/2 (190.5)	1 (25.4)	6 (152.4)	3/4 (19)	5 (127)	4
	300	(105)	(238)	(125)	(300)	8-1/4 (209.5)	1-1/8 (28.6)	6-5/8 (168.3)	7/8 (22.2)	5 (127)	8
4 (100)	150	4-7/8	9-19/32	5-7/8	13-3/4	9 (228.8)	15/32 (23.8)	7-1/2 (190.5)	3/4 (19)	6-3/16 (157.2)	8
	300	(124)	(244)	(149)	(350)	6-1/16 (254)	1-1/4 (31.7)	8 (200)	7/8 (22.2)	6-3/16 (157.2)	
6 (150)	150	6	10-3/8	7-1/2	18-7/8	11 (279.4)	1 (25.4)	9-1/2 (241.3)	7/8 (22.2)	8-1/2 (215.9)	8
	300	(150)	(264)	(188)	(480)	12-1/2 (317.5)	1-1/2 (36.5)	10-5/8 (269.9)	7/8 (22.2)	8-1/2 (215.9)	12
8 (200)	150	6-5/8	11-1/8	8-1/2	23-5/8	13-1/2 (343)	1-1/8 (28.6)	11-3/4 (298.4)	7/8 (22.2)	10-5/8 (270)	8
	300	(170)	(284)	(215)	(600)	15 (381)	1-5/8 (41.3)	13 (330.2)	1 (25.2)	10-5/8 (270)	12
12 (300)	150	13-1/4	13-1/2	16-5/8	39-3/8	19 (482.6)	1-1/4 (31.7)	17 (431.8)	1 (25.4)	15 (381)	12
	300	(336)	(341)	(423)	(1000)	-	-	-	-	-	
16 (400)	150	17	14-3/4	21-1/2	50	23-1/2 (597)	1-1/2 (36.5)	21-1/4 (539.7)	1-1/8 (28.6)	18-1/2 (470)	16
	300	(434)	(374)	(544)	(1270)	-	-	-	-	-	

FIGURE 2-2. SWIRLMETER OUTLINE DIMENSIONS

2.5 Meter Installation

To assure optimum meter performance, the meter should be installed in accordance with the upstream and downstream straight run piping requirements shown in Figure 1-6. The straight run piping should be schedule 80 or lighter pipe. Process flanges should be raised face.

Remove the covers used to protect the meter inlet and outlet surfaces from damage during shipment. Place the two supplied flange gaskets against the upstream and downstream flange faces. Align the gasket holes with the flange hole pattern. When installing the flange gaskets, make sure that the gaskets fit properly and are aligned properly so that they don't project into the pipe line causing an alteration of the flow profile. A change in flow profile can adversely affect meter accuracy.

Mounting bolts and nuts are supplied by the user. During installation, make certain that the **flow direction arrow** on the meter body is oriented in accordance with the process flow.

With the meter safely supported, install the bolts through the meter and process flanges. Bolts and nuts should be lubricated with a graphite based lubricant. Assemble the nuts to the bolts hand tight. Tighten the flange nuts in a diagonal or "star" pattern as shown in Figure 2-3 to equalize pressure on the flange face and gaskets. Bolt/nut torque should be limited to that which will provide a leakproof seal.

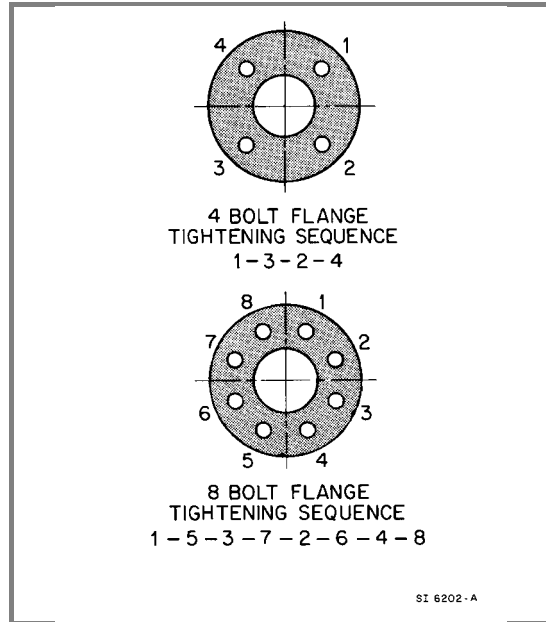

FIGURE 2-3. FLANGE BOLT TIGHTENING SEQUENCE

When correctly installed, the installation should look like that shown in Figure 2-4 below.

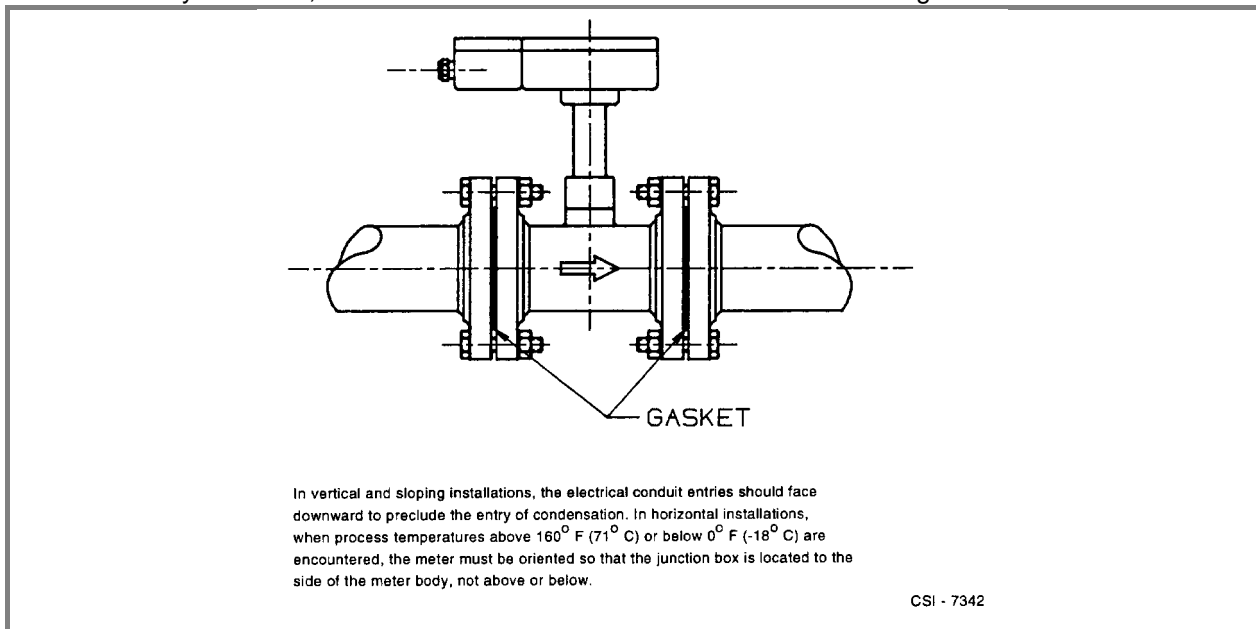

FIGURE 2-4. FLANGE PROCESS CONNECTIONS

2.6 Electrical Interconnections

Power connections to Model ST are made to the Connection Board Assembly located in the electronics housing interconnection wiring box (the smaller of the two boxes comprising the electronics housing). The layout of the Connection Board is shown in Figure 2-5. In addition to the power supply connections, this circuit board assembly also contains the STEP, DATA & C/CE pushbutton switches required for menu data entry as discussed in Chapter 3.0.

Terminal block 1x1 provides the means to connect the power supply cable with the positive lead attaching to the left terminal (TW+) and the negative to the right (TW-). The installation site must be provided with a source of power that is compatible with the signal converter power requirements. Refer to the instrument tag and Figures 2-7 & 2-8 for power requirements and/or limitations.

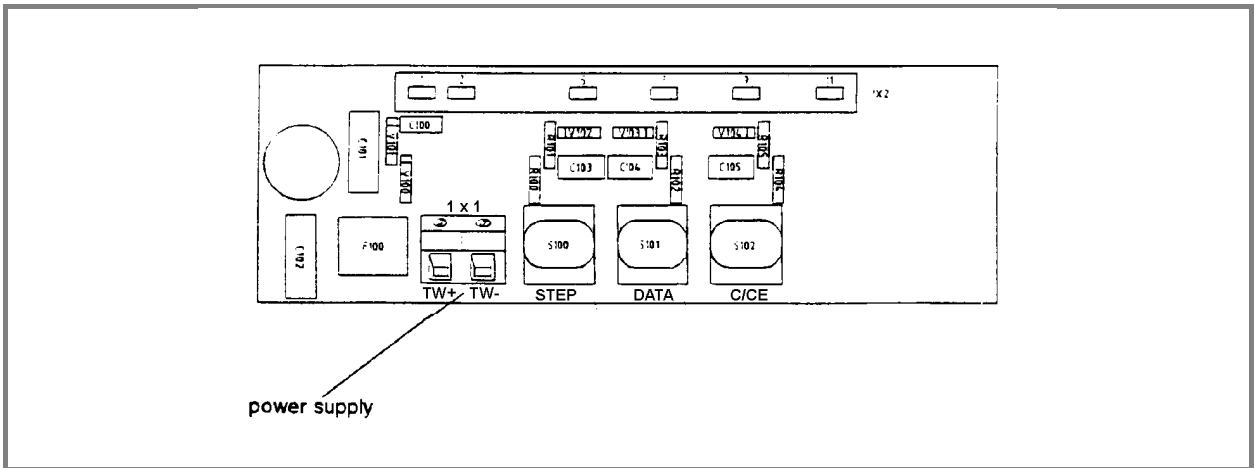

FIGURE 2-5. CONVERTER CONNECTION BOARD LAYOUT

Since the 10ST1000 is an integral meter, the sensor leads pass through the "tower assembly" and connect directly to pins 2B & 19 of the 3x5 terminal block on the Analog Board Assembly. This circuit board assembly also contains preamplification and signal-processing circuitry as well as the programming switches referenced in Section 4.4. A layout of the Analog Board is shown in Figure 2-6 below. The Analog Board assembly is accessible only by removing the cover to the Electronics Compartment and access should only be required for servicing or diagnostic purposes.

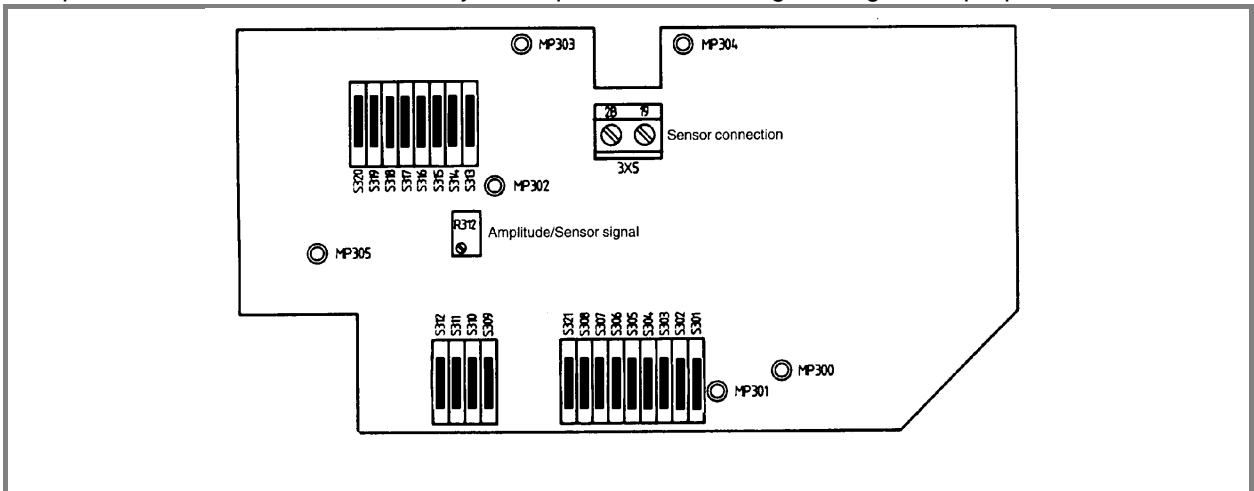

FIGURE 2-6. CONVERTER ANALOG BOARD LAYOUT

For reference purposes, Figures 2-7 and 2-8 show the external interconnections schematically.

The flowmeter housing covers are removable and may be removed for access during installation and maintenance. Remove the covers from the housing by loosening the screws on the covers. Replace the covers when the installation has been completed and **before** power is applied to the equipment.

Make certain that covers are replaced properly after maintenance by using the following procedures:

- Check that gaskets are properly seated and are not pinched or stretched.
- Check that gasket surfaces are clean and free of grease or other contaminants.
- Align covers on housing and re-install bolts.
- Tighten bolts finger tight.
- Finish tightening bolts in a "star" pattern to distribute force evenly.

CAUTION

All unused conduit entrances must have pipe plugs installed. This is required to maintain the NEMA 4X enclosure rating.

2.7 Conduit Seal and Pressure Relief

In accordance with the National Electrical Code (NEC) ANSI/NFPA 70, Article 501-5(f)(3), the flowmeter includes a **pressure relief**. This safety feature considers the remote possibility of a primary seal failure between the meter body and the electronic housing.

The **pressure relief** is located in the flowmeter electronics housing in the center of the cover joint on the side opposite the conduit connection near the digital display. It may be seen by looking at the end of the electronics housing near the digital display. At the junction of the housing and the cover, a small rectangular "notch" approximately 1/2 in. wide and 1/16 in. high may be seen. If the primary seal should fail, the pressure relief will vent the process through this notch, preventing an over pressurization and potentially dangerous failure of the electronics housing. It is the user's responsibility to be aware of this safety feature and to consider the unlikely event of its functioning. Based on knowledge of the process and meter application, the user should consider the use of deflectors to safely direct the vented process away from any attending personnel.

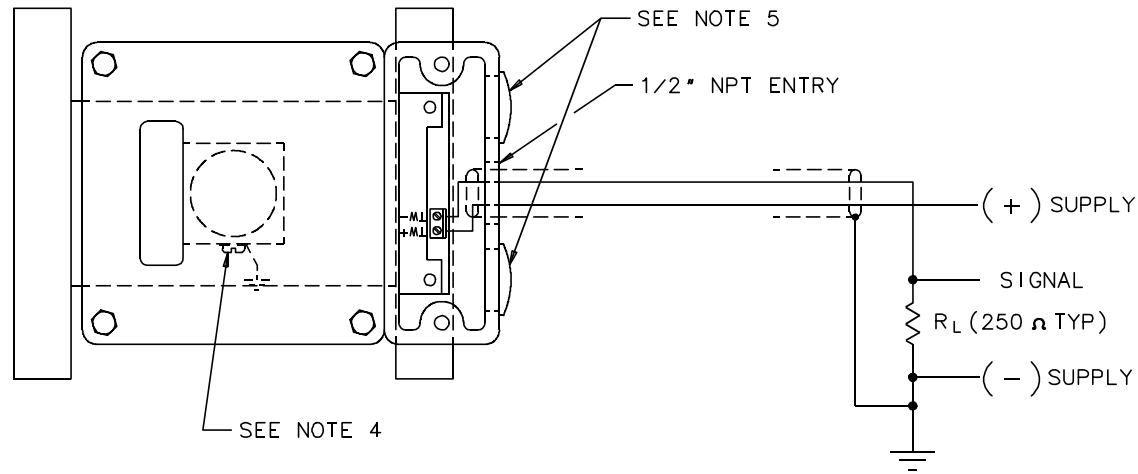

INSTALLATION NOTES:

1. EQUIPMENT AND WIRING TO BE INSTALLED IN ACCORDANCE WITH ANSI/NFPA 70 (NATIONAL ELECTRICAL CODE) AND LOCAL CODE REQUIREMENTS.
2. SHIELDED CABLE IS REQUIRED. THE UNTERMINATED END OF THE SHIELD SHALL BE INSULATED FROM THE FLOWMETER.
3. USE NEC TYPE CM, 22 AWG MINIMUM (BELDEN 8761 OR EQUIVALENT). FOR PROCESS TEMPERATURES GREATER THAN 212° F (100° C) AND PLENUM SERVICE, USE NEC TYPE CMP (BELDEN 88761 OR EQUIVALENT).
4. BODY OF SWIRL/VORTEX FLOWMETER SHALL BE GROUNDED THROUGH THE PIPELINE FLANGES OR THROUGH THE SWIRL/VORTEX METER EXTERNAL GROUND TERMINAL.
5. SEALS REQUIRED AT UNUSED CONDUIT ENTRIES TO MAINTAIN NEMA 4 ENCLOSURE RATING.

POWER SUPPLY: 14 TO 46 V dc

LOAD RESISTANCE (R_L): 0 Ω MIN. AT 14 V
1600 Ω MAX. AT 46 V

AMBIENT LIMITS: -4° TO 140° F (-20° TO 60° C)

(REF ID-10-1100 REV 4)

FIGURE 2-7. INTERCONNECTION WIRING DIAGRAM FOR NON-HAZARDOUS LOCATIONS

3.0 DATA ENTRY AND CONFIGURATION

3.1 Pushbuttons and Display

During normal operation, totalizer units and range units are shown in the display window. The display is configured as described in Sub-section 4.3.21.

Typical Display: Visible through window in electronics cover.

Flow Rate	→	Qv 50	usgpm
Total	→	Qv 5600	usgal

Pushbuttons: Located on Connection Circuit Board in signal converter interconnection junction box (Refer to Section 2.6).

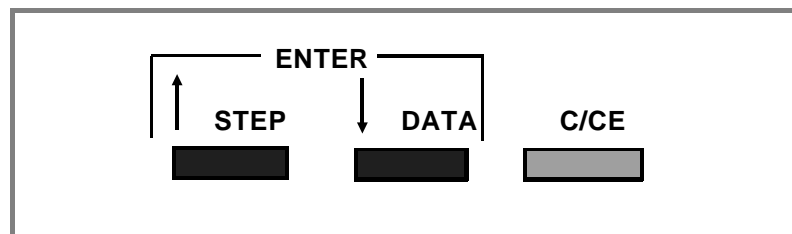

FIGURE 3-1. PROGRAMMING PUSH-BUTTONS

3.2 Pushbutton Functions

All data base interrogations and changes are made through three pushbutton switches located in the Converter's interconnection junction compartment and shown in Figures 2-6 and 3-1. They are identified as "STEP", "DATA", and "C/CE". To gain access to the data base, it is necessary to leave the normal "**monitoring mode**" and enter the "**configuration mode**". This is accomplished by pressing the pushbutton on the right which is identified as the "C/CE" pushbutton. The various parameters of the data base can then be viewed by moving up or down through the menu by pressing one of the two buttons to the left of "C/CE" identified as "STEP" and "DATA". Changes are entered by pressing the "STEP" and "DATA" pushbuttons simultaneously. This simultaneous action constitutes the "ENTER" function. If no entries or changes are made within 20 seconds the unit will automatically revert to the monitoring mode.

When the "C/CE" pushbutton is pressed, the display shows messages and database parameters instead of flow data. Pressing "C/CE" again will revert back to the monitoring mode. The first message displayed the first time the "C/CE" button is pressed after power up is "Prog. Protection ON". As long as program protection is **on**, database parameters can be displayed but not changed. In order to change parameters, program protection must be turned **off** (the procedure will be described later). The parameters may be changed using the "STEP" and "DATA" pushbuttons. To make a change take effect, use the "ENTER" function.

There are two ways to make changes to the data base: entering a **direct numeric** value and making a selection from the **menu or tabular entry**.

- **Tabular Entry** is done using the arrow keys to select a value from the menu. The selected value is entered using the "ENTER" buttons.
- **Direct Numeric Entry** is done using the "DATA" and "STEP" buttons. The "DATA" button is used to select numbers 0 through 9, decimal point, minus sign and a blank space. The "STEP" button is used to move to the next digit.

Access to the data base is gained by using the "ENTER" function. When the "ENTER" buttons are pressed, a cursor is added to the right of the data on the bottom line of the display if selection is to be made from the menu.

When the parameter to be changed is a numerical value, the top line will list the parameter name, and the bottom line will show the cursor on the left and the units on the right.

The number "0" over the cursor will now increase by one each time the "DATA" button is pressed. If it is pressed when the number nine (9) is over the cursor a decimal point (.) will appear. If it is pressed again a minus sign (-) will appear, and if it is pressed again a space will appear ().

The number can only be increased. If the required number is passed it is not possible to back up. It is necessary to continue advancing the number until the required value appears again. When the number appears above the cursor, press the "STEP" button once and the cursor will move one space to the right. A zero will again appear over the cursor, and the next digit can be selected. If an error is made in the selection of a number it can be corrected by pressing the "C/CE" button. The entry will be cleared, and a new entry can be made.

When the required value is reached, press the "ENTER" buttons and the value will be entered into memory. It will then be evaluated by the computer, and if it is not compatible with other selected parameters it will be rejected. An ERROR message will appear to indicate that the entry is not acceptable.

The operation of the display and the differences between the two data entry methods described above is shown summarized graphically in Section 3.3

Section 3.4 shows the menu and sub-menu structure of the converter. The sequence of progression shown assumes advancing is done using the "STEP" button after pressing "C/CE" to enter the "**configuration mode**".

3.3 Instructions For Entering Data Into the Converter

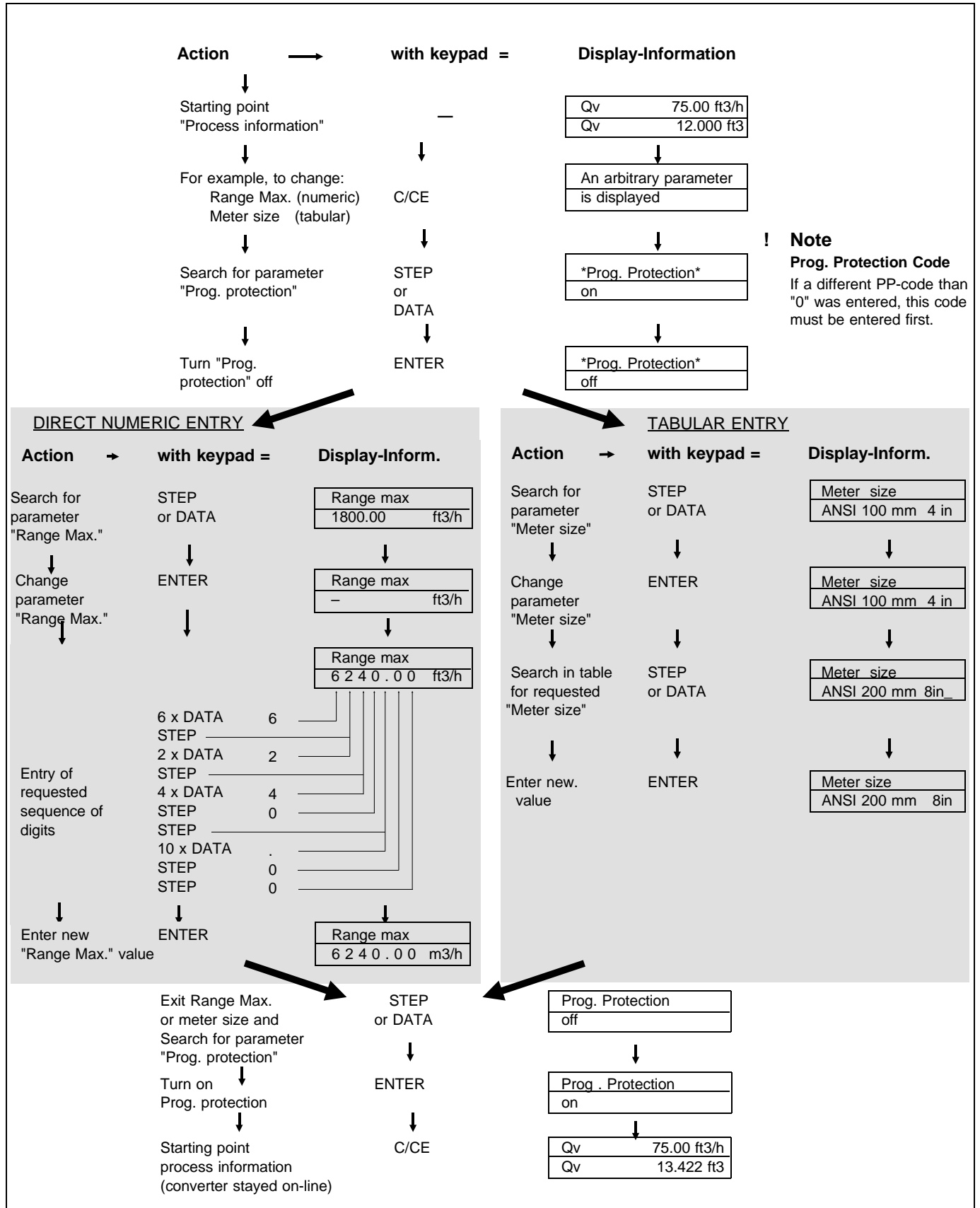

3.4 Parameter Summary and Data Entry

Submenu / Parameter	Entry Mode (Tabular / Numeric)	Description
<div style="border: 1px solid black; padding: 2px; display: inline-block;">10VT1000 03/95 D699B117U01 A.52</div>	Read-Only	Display of Model number, firmware date, firmware part number and firmware version.
<div style="border: 1px solid black; padding: 2px; display: inline-block;">Prog. Protection On</div>		Data entry is only possible by turning "Prog. Protection" off
Enter	<div style="border: 1px solid black; padding: 2px; display: inline-block;">Prog. Protection Off</div>	"Prog. Protection" is "ON", by default, when power is first applied. Selections available: on / off
<div style="border: 1px solid black; padding: 2px; display: inline-block;">Language English</div>	Tabular	Press C/CE to exit submenu
Enter	<div style="border: 1px solid black; padding: 2px; display: inline-block;">Language English</div>	Selects whether menus are displayed in German or English
	<div style="border: 1px solid black; padding: 2px; display: inline-block;">Language German</div>	
<div style="border: 1px solid black; padding: 2px; display: inline-block;">Primary Swirlmeter</div>		
<div style="border: 1px solid black; padding: 2px; display: inline-block;">Fluid Liquid</div>	Tabular	Press C/CE to exit submenu
Enter	<div style="border: 1px solid black; padding: 2px; display: inline-block;">Fluid Gas</div>	Selects the proper process fluid for the application
	<div style="border: 1px solid black; padding: 2px; display: inline-block;">Fluid Liquid</div>	
<div style="border: 1px solid black; padding: 2px; display: inline-block;">Meter Size ANSI 150mm 6 in</div>	Tabular	Selections: ANSI Sizes - 1/2 in. (15 mm) * 3/4 in. (20 mm) 1 in. (25 mm) 1-1/4 in. (32 mm) 2 in. (50 mm) 3 in. (80 mm) 4 in. (100 mm) 6 in. (150 mm) 8 in. (200 mm) 12 in. (300 mm) 16 in. (400 mm)
<div style="border: 1px solid black; padding: 2px; display: inline-block;">Median k-factor</div>	Read-Only	Displays Median K-Factor. Independent of whether Median or Linearization is selected in K-Factor submenu.

* This meter size is not presently available

10ST1000 SWIRLMETER INSTRUCTION BULLETIN

Submenu / Parameter	Entry Mode	Description
<div style="border: 1px solid black; padding: 2px; width: fit-content;">Flow Mode Actual Flow</div>	Tabular	Press C/CE to exit submenu
Enter		
<div style="border: 1px solid black; padding: 2px; width: fit-content;">Flow Mode Actual Flow</div>		
<div style="border: 1px solid black; padding: 2px; width: fit-content;">Flow Mode Standard Flow</div>		Selects the desired flow measurement mode. The appropriate units must be chosen using the "Unit"
<div style="border: 1px solid black; padding: 2px; width: fit-content;">Flow Mode Mass Flow</div>		
<div style="border: 1px solid black; padding: 2px; width: fit-content;">Compressibility 1.00 *</div>	Numeric	Conversion factor required for Standard Flow. Allows entry of numbers between 0.001 and 1000. See Section 4.3.9.
<div style="border: 1px solid black; padding: 2px; width: fit-content;">Unit Density **</div>	Tabular	Selectable units are: g/ml, g/cm ³ , g/l, kg/l, kg/m ³ , lb/ft ³ , lb/ugl
<div style="border: 1px solid black; padding: 2px; width: fit-content;">Actual Density **</div>	Numeric	Allows entry of numbers between 0.001 and 1000.
<div style="border: 1px solid black; padding: 2px; width: fit-content;">Unit Qv ft³/m</div>	Tabular	Selectable units are: l/s, l/m, l/h, igps, igpm, igph, igpd, usgpm, usgpm, usgph, usgpd, ft ³ /s, ft ³ /m, ft ³ /h, ft ³ /d, m ³ /s, m ³ /m, m ³ /h, m ³ /d, bbl/s, bbl/m, bbl/h, bbl/d. Note: bbl = 42 gallons
<div style="border: 1px solid black; padding: 2px; width: fit-content;">Unit Qm **</div>	Tabular	Selectable units are: g/s, g/m, g/h, kg/s, kg/m, kg/h, kg/d, t/m, t/h, t/d, lb/s, lb/m, lb/h, lb/d Note: t = metric tons (1000kg)
<div style="border: 1px solid black; padding: 2px; width: fit-content;">Meter Range Max</div>	Read-Only	Indication of maximum volumetric flow rate based on meter size and fluid selected. This parameter may be programmed to a different value by selecting "Programmable" from the "Meter Range Max" menu that becomes available after entering the code number.

* Only appears if "Standard Flow" is selected as the flow mode

** Only appear if "Mass Flow" is selected as the flow mode

Submenu / Parameter	Entry Mode	Description
Range Max	Numeric	Flow rate at which the output current becomes 20mA. Value must be between 15% and 115% of Meter Range Max.
Range Min	Numeric	Flow rate at which the output current becomes 4mA. If set to value other than zero, output current will be forced to 4mA at \leq the Range Min value. Value entered must be equal to or less than 10% of Meter Range Max.
Submenu Totalizer	Tabular	Press <input type="button" value="C/CE"/> to exit submenu
Enter	Function Totalizer reset	Value of Totalizer may be reset by pressing <input type="button" value="Enter"/>
	Unit totalizer ft3	Selections for Actual & Standard Flow: ft3, usgal, igal, bbl, l, m3 Selections for Mass Flow: kg, t, lb, g
	Totalizer Qv	Shows accumulated value of flow units.
	Overflow 0	Incremented each time the Totalizer value exceeds its 10,000,000 maximum count. Capacity of overflow register is 65,535 counts.
Submenu Pulse Output	Numeric	Press <input type="button" value="C/CE"/> to exit submenu
Enter	Pulse factor 100.00 1/ft3	This parameter requires special hardware that is presently not available.
	Pulse width	
Damping 3.0 s	Numeric	Controls the rate at which the unit responds to changes in the process flow rate. Allows entries of numbers between 1.0 and 100 seconds.

Submenu / Parameter	Entry Mode	Description
<div style="border: 1px solid black; padding: 2px; width: fit-content;">Submenu Current Output</div>	Tabular	<p>Press C/CE to exit submenu</p> <p>Selections available: Current + HART Current + pulse *</p> <p>* Presently not available</p> <p>Selections available: 3.85 mA 22.40 mA</p> <p>Sets the output current to the selected current value in response to Errors 5 (EEPROM) or 6 (Totalizer) conditions.</p>
Enter	<div style="border: 1px solid black; padding: 2px; width: fit-content;">Current output Current + HART</div>	
	<div style="border: 1px solid black; padding: 2px; width: fit-content;">Iout at alarm 22.40 mA</div>	
<div style="border: 1px solid black; padding: 2px; width: fit-content;">Submenu Display</div>	Tabular	<p>Press C/CE to exit submenu</p> <p>Allows both lines of the digital display to be independently configured to indicate different process parameters.</p> <p>Selections (for each display line) are :</p> <ul style="list-style-type: none"> Qn standard flow * Qv actual flow Qm mass flow ** Percent Bargraph Totalizer Frequency <p>* Only appears if Standard Flow is selected as Flow Mode ** Only appears if Mass Flow is selected as Flow Mode</p>
Enter	<div style="border: 1px solid black; padding: 2px; width: fit-content;">Display 1. line Qv actual flow</div>	
	<div style="border: 1px solid black; padding: 2px; width: fit-content;">Display 2. line Totalizer</div>	
<div style="border: 1px solid black; padding: 2px; width: fit-content;">Submenu Self-Check</div>	Tabular	<p>Press C/CE to exit submenu</p> <p>Performs functional check of internal hardware and sub-systems. Additional self-check parameters are shown on the following page.</p>
Enter	<div style="border: 1px solid black; padding: 2px; width: fit-content;">Function NVRAM</div>	
	<div style="border: 1px solid black; padding: 2px; width: fit-content;">Function EPROM</div>	
	<div style="border: 1px solid black; padding: 2px; width: fit-content;">Function EEPROM</div>	
	<div style="border: 1px solid black; padding: 2px; width: fit-content;">Function Iout</div>	
	<div style="border: 1px solid black; padding: 2px; width: fit-content;">Function Fout</div>	

Submenu / Parameter	Entry Mode	Description
<div style="border: 1px solid black; padding: 2px; width: fit-content;">Submenu Error Register</div>	<div style="border: 1px solid black; padding: 2px; width: fit-content;">Function HART-Transmitter</div>	Additional functional check parameters
	<div style="border: 1px solid black; padding: 2px; width: fit-content;">Function HART-Command</div>	
	<div style="border: 1px solid black; padding: 2px; width: fit-content;">Function Display</div>	
	Tabular	Press C/CE to exit submenu
		Enter
	<div style="border: 1px solid black; padding: 2px; width: fit-content;">Mains interrupt 3</div>	Shows the number of power interruptions that have occurred since the last time the Error Register was reset.

Submenu / Parameter	Entry Mode	Description
The following menu parameters appear when the unit's Code Number is entered		
Code Number ****	Numeric	Entering the 4-digit code number causes the menu functions shown below to appear. Default code number is 1000.
Instrument Number	Numeric	An instrument identification number may be entered for "ID" purposes. Number must be less than 65,535.
Submenu k-factor	Tabular / Numeric	Press <input type="button" value="C/CE"/> to exit submenu
Enter	k-Linearization Median	Selections available: Median 5 points 4 points 3 points 2 points
	Median k-factor 52000 1/m3	Allows numeric entry of median k-factor value if "Median" is selected above.
	f1 2500 Hz	Allows numeric entry of "f" and "k" value sets if any of the "point-linearization" options above are selected. One "f" and "k" value set per linearization point is required.
	k1 52000 1/m3	
Meter Range Max Fixed	Tabular	Press <input type="button" value="C/CE"/> to exit submenu
Enter	Meter Range Max Fixed	Selects whether the "Meter Range Max" parameter is the read-only value determined by the firmware or may be numerically programmed by the user.
	Meter Range Max Programmable	

Submenu / Parameter	Entry Mode	Description
Function Reset Error	Enter	Pressing "Reset" function clears all error codes that have accumulated in the Error Register.
Function Init EEPROM	Enter	Pressing "Reset" function initializes EEPROM and restores any programmed parameters stored there to their default values.
Function Adjust Iout 4mA	Numeric	Enables precise calibration of 4mA output current.
Function Adjust Iout 20mA	Numeric	Enables precise calibration of 20mA output current.
Function Minimum Current		Press <input type="text" value="C/CE"/> to exit submenu
Enter	Test min current	Shuts off output current regulation and allows measurement of the current being consumed by the electronics. This current must be less than 4mA for proper operation.
Error 9 Off	Tabular	Press <input type="text" value="C/CE"/> to exit submenu
Enter	Error 9 On	Allows control of whether output current "latches" at the alarm value in response to an overrange condition, requiring a manual reset to restore normal operation after the overrange condition is corrected. Selections available: on / off

4.0 START-UP AND OPERATION

4.1 Start-Up

Prior to initial system start-up, verify that the meter is properly installed. Check flow direction as indicated on the meter body and wiring interconnections as shown in Figures 2-8 or 2-9 of Installation Chapter 2.0.

Verify that the power supply is the correct value according to the power requirements of the signal converter and that it is connected with the proper polarity.

If everything is properly installed and connected, turn on the power to the meter. The LCD display should become active and display the selected flow information in two lines.

Using the pushbuttons located in the signal converter interconnection junction box (see Sections 2.7 and 3.2), verify that the correct operating parameters have been entered as described in this section.

If everything appears to be operating properly, initiate process flow through the flowmeter. Flow measurement and output signal transmission should begin as the process fluid flows through the meter.

4.2 Error Messages

Error messages replace the flow rate indication in the top line of the display when certain failure conditions exist or when an attempt has been made to enter an unacceptable value.

TABLE 4-1. DEFINITION OF ERROR MESSAGES

Error Code	Description	Cause
3 (a)	Flowrate > 115%	Flowrate is greater than 115% of Range Maximum.
5 (b)	EEPROM Defect	Data error in EEPROM.
6	Totalizer Error	Totalizer value is invalid.
9 (c)	Qv > 115% Qmax DN	Flowrate greater than 115% of Meter Range Maximum.

(a) Self-resetting alarm condition. Normal operation resumes when alarm condition clears.

(b) Refer to Sub-Section 4.3.24.4 & 4.3.24.5.

(c) This alarm condition forces the output current to 22.4 mA and to "latch" there. It is not self-resetting. When the alarm condition has cleared, the meter may be reset by pressing any button on the keypad. Code 9 can be disabled per Sub-Section 4.3.24.9.

4.3 Menu Display and Selections

NOTE
Normal measurement range extends to 115% of Meter Range Max.

NOTE
The abbreviations shown in Table 4-2 are applicable to the Unit menu selections in Section 4.3.

TABLE 4-2. UNITS OF MEASURE

Abbreviations	Definition
usgal	US gallons
igal	imperial gallons
bbl	barrels (42 gallons)
l	liters
ml	milliliters
m ³	cubic meters
cm ³	cubic centimeters
ft ³	cubic feet
kg	kilograms
t	metric tons
lb	pounds
g	grams

4.3.1 Firmware Version

The firmware level and the model number are shown in the display with the model number and firmware release date on the top line and the EPROM identification and firmware level on the bottom line. Changes to the firmware can only be made by replacing the EPROM. When communicating with Bailey-Fischer & Porter, please reference the firmware version of the instrument.

The Functional Flowchart shown in Figure 4-1 gives a pictorial overview of the top-level menu structure of this version of firmware. Functions of these menu parameters and their sub-menu breakdowns are explained in more detail following the flowchart.

NOTE

Since the 10ST1000 uses the same firmware as the 10VT1000 Vortex meter, the Swirlmeter display will indicate "10VT1000" as the model number. This procedure has been prepared based on firmware version A.52. Other versions will be similar, but not identical and may have features different from those discussed in this section.

10VT1000	03/95
D699B117U01	A.52

4.3.2 Program Protection

The Program Protection is automatically turned **ON** during power-up. Parameters **cannot** be changed when Program Protection is **ON**. Parameters can only be changed when the Program Protection is in the **OFF** mode. To change from ON to OFF (or vice-versa), press ENTER. When changing calibration parameters (see Code Number sub-section 4.3.24), Program Protection is automatically turned off when the code number is entered. Program Protection will automatically revert to **ON** if not done manually.

Program Protection

Menu Choices: on
 off

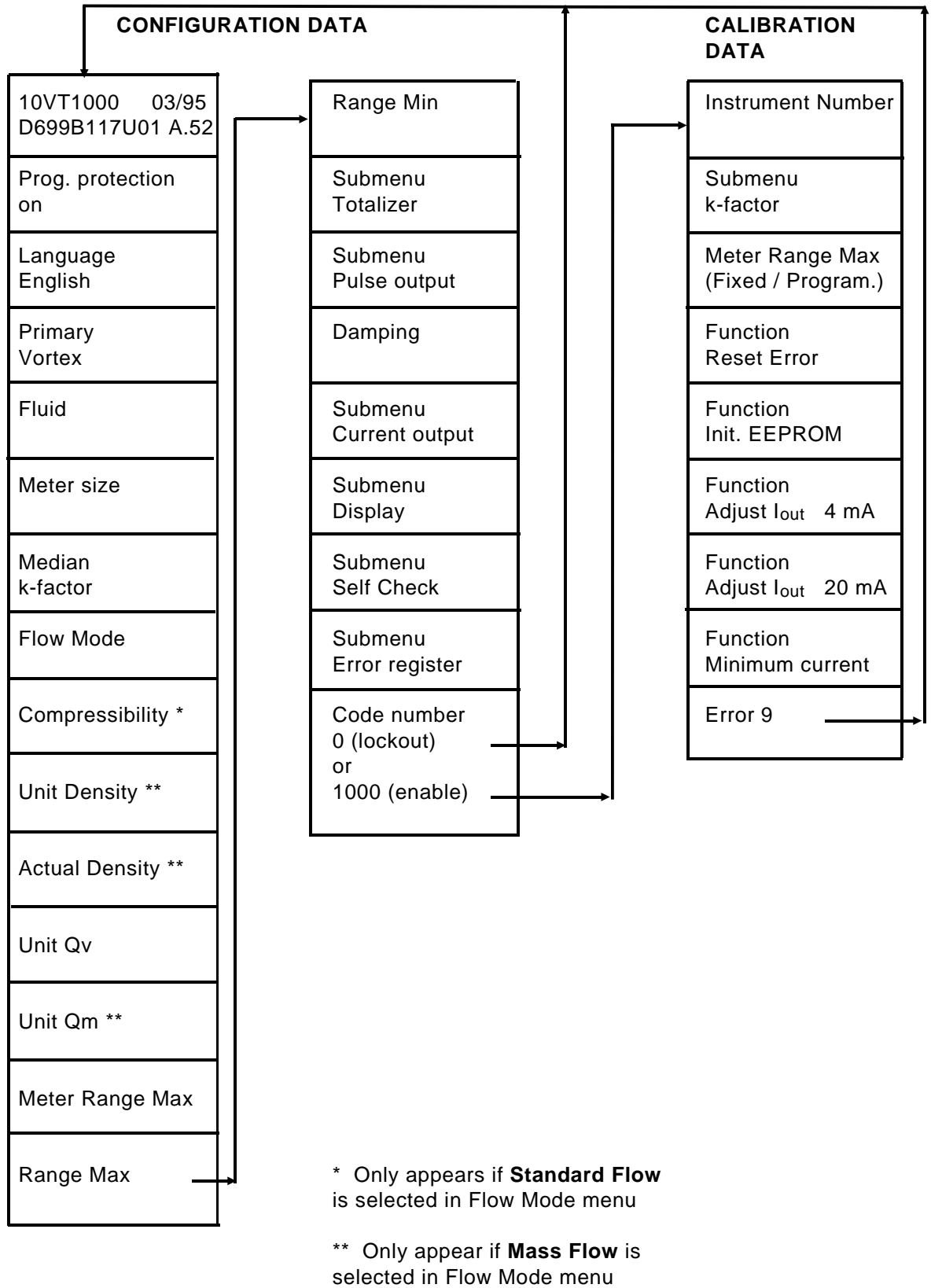

FIGURE 4-1. FLOWCHART OF PARAMETERS

4.3.3 Language

Menu choice "English" is entered by Bailey-Fischer & Porter. To change this selection, press ENTER and use the arrow keys to change the selection; then press ENTER.

Language English

Menu Choices: English
 German

4.3.4 Primary

Entered by Bailey-Fischer & Porter.

Primary Swirlmeter

See NOTE A.

Menu Choices: Vortex (not applicable)
 Swirlmeter

4.3.5 Fluid

To select the appropriate process fluid, press ENTER and use the arrow keys to make a selection; then press ENTER.

Fluid

See NOTE A.

Menu Choices: Gas
 Liquid

4.3.6 Meter Size

Enter the applicable meter size. Only the menu choices that appear in the following table are applicable to meters built in the US by Bailey-Fischer & Porter. To make an entry, press ENTER and use the arrow keys to scroll through the menu. When the appropriate size appears, press ENTER and the size will be entered into memory.

Meter Size

See NOTE A.

Menu Size Choices	
inches	mm
1/2*	15*
3/4	20
1	25
1 1/4	32
2	50
3	80
4	100
6	150
8	200
12	300
16	400

* This meter size is not presently available

<p>NOTE A: Primary, Fluid & Meter Size selections in Sections 4.3.4, 4.3.5 & 4.3.6 respectively will be replaced by asterisks (*) if "Programmable" is selected as the parameter in Section 4.3.24.3.</p>
--

4.3.7 Median k-factor

This menu provides a means for monitoring the average k-factor value regardless of how many points were selected for the linearization in Sub-Section 4.3.24.2. This is a read only parameter and the value that appears on the display must match the value stamped on the meter's Model Number tag. Units for this "meter-constant" parameter are cycles/m³.

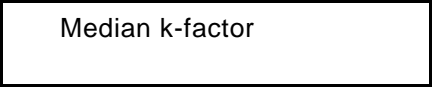

4.3.8 Flow Mode

To select the desired flow mode, press ENTER and use the arrow keys to make a selection. Once the selection is made, press ENTER to save it.

Actual flow - actual volumetric flow

Mass flow - mass flow using operating density

Standard flow - standard flow under standard temperature and pressure conditions

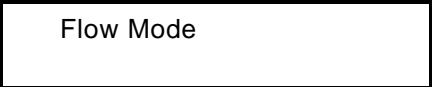

Menu Choices: actual flow
 mass flow
 standard flow

4.3.9 Compressibility

This menu appears only if Standard flow is selected for the Flow Mode. This number must be entered to convert the measured process flow to Standard flow conditions based on the specific process operating pressure and temperature conditions.

The compressibility factor to be entered is calculated from the following equation:

$$\text{Compressibility} = \left(\frac{P}{14.7} \right) \times \left(\frac{530}{460 + T} \right)$$

where: P = process operating pressure in psia
 T = process operating temperature in °F

Range of entry values permitted is 0.001 to 1000.

4.3.10 Unit Density

Used with Mass Flow only (refer to Section 4.3.8). To make an entry, press ENTER and use the arrow keys to scroll through the menu. When the appropriate selection appears, press ENTER.

Unit Density

Menu Choices:
g/ml
g/cm ³
g/l
kg/l
kg/m ³
lb/ft ³
lb/ugl

4.3.11 Actual Density

Enter operating density in applicable units selected in Section 4.3.10 - **used with Mass Flow only (refer to Section 4.3.8).** To make an entry, press ENTER and use the "STEP" and arrow keys to enter a value, then press ENTER.

Actual density

4.3.12 Unit Qv (volumetric)

Used with Actual & Standard Flow Modes only (refer to Section 4.3.8). To make an entry, press ENTER and use the arrow keys to scroll through the menu. When the appropriate selection appears, press ENTER.

Unit Qv

Menu Choices:					
l/s	igps	usgps	ft ³ /s	m ³ /s	*bbl/s
l/m	igpm	uspm	ft ³ /m	m ³ /m	*bbl/m
l/h	igph	usgph	ft ³ /h	m ³ /h	*bbl/h
---	igpd	usmgd	ft ³ /d	m ³ /d	*bbl/d

*bbl = 42 gallons

4.3.13 Unit Qm (mass flow)

Used with Mass Flow only (refer to Section 4.3.8). To make an entry, press ENTER and use the arrow keys to scroll through the menu. When the appropriate selection appears, press ENTER.

Unit Qm

Menu Choices:			
g/s	kg/s	*t/m	lb/s
g/m	kg/m	*t/h	lb/m
g/h	kg/h	*t/d	lb/h
---	kg/d	---	lb/d

* t = metric tons (1000 kg)

4.3.14 Meter Range Maximum (Q_{max} DN)

Maximum volumetric flow rate per meter size. This parameter may be programmed as described in Section 4.3.24.3. Range maximum (which determines the flow rate where output current equals 20 mA) is set as described in Section 4.3.15.

Meter Range Max

NOTE
If Mass Flow is selected as the flow mode in Section 4.3.8, the units of Meter Range Max. will continue to be displayed in the volumetric flow units selected in Section 4.3.12.

4.3.15 Range Maximum (Q_{max})

Range Maximum is the flow rate at which the output shall be equal to 20 mA. Use the STEP and DATA keys to enter a value that corresponds to 20 mA. Value must be between 15% and 115% of Meter Range Maximum [Q_{max} DN] (refer to Section 4.5.14).

Range Max

If **Mass Flow** is selected in Section 4.3.8, the **Range Max** units will be displayed in the units selected for Q_m in Section 4.3.13 while **Meter Range Max.** and **Range Min.** will continue to be displayed in the volumetric units selected in Section 4.3.12. For comparison purposes, the volumetric units value for **Range Max** can be calculated from the following equation:

$$Q_v = \frac{Q_m}{DENSITY}$$

where Q_v = Volumetric flow rate
 Q_m = Mass flow rate
 Density = Actual Density value entered in para. 4.3.11

4.3.16 Range Minimum (Q_{min})

When flowrate is below Range Minimum the output is driven to 4 mA. Use the STEP and DATA keys to enter a value that corresponds to the minimum volumetric flow to be displayed; then press ENTER. Zero flow equals 4 mA. Value must be equal to or less than 10% of Meter Range Maximum (refer to Section 4.3.14).

Range Min

NOTE
If Mass Flow is selected as the flow mode in Section 4.3.8, the units of Range Min. will continue to be displayed in the volumetric flow units selected in Section 4.3.12.

4.3.16.1 Current Output vs. Range Min. Setting

The operation of the current output is shown graphically in Figure 4-2 below. If flow is above the value of the Range Min (Q_{min}) setting, the current follows a linear path which is determined by a straight line passing between 4mA at zero flow and 20mA at the Range Max. (Q_{max}) value. The output current is forced to 4mA when flow conditions fall below the value of the Range Min. (Q_{min}) setting.

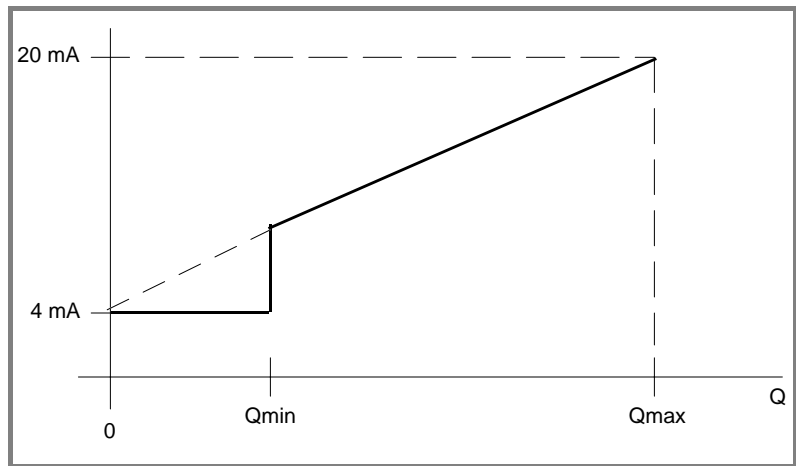

FIGURE 4-2. CURRENT OUTPUT OPERATION

4.3.17 Sub Menu Totalizer

4.3.17.1 Unit Totalizer

To make an entry, press ENTER and use the arrow keys to scroll through the menu. When the appropriate selection appears, press ENTER. The appropriate **Flow Mode** must be selected in Section 4.3.8.

Unit Totalizer

Totalizer menu selections:

Menu Choices:	
Actual flow	Mass flow
usgal	kg
igal	**t
*bbl	lb
l	g
m ³	---
ft ³	---

*bbl = 42 gallons

**t = metric tons (1000 kg)

4.3.17.2 Totalizer

The totalizer sums the flow in accordance with the selected flow mode. An overflow is activated each time the totalizer count exceeds 10,000,000 (refer to Section 4.3.17.3). The maximum number of overflows which can be stored in the overflow register is 65,535. Therefore, the maximum totalizer count is:

$$65,535 \times 10,000,000 = 655,350,000,000$$

This is a read only parameter.

Totalizer

4.3.17.3 Overflow

When the **totalizer** reaches its maximum count it "rolls over" to zero. Each "roll over" is counted as an **overflow** and stored in the overflow register. This is a read only parameter.

Example:

Number of overflows = 12
 Maximum totalizer count = 10,000,000
 Present totalizer count = 4,789

$$12 \times 10,000,000 = 120,000,000$$

$$120,000,000 + 4,789 = 120,004,789$$

Overflow
0

4.3.17.4 Function Totalizer Reset

Press ENTER to reset the totalizer and overflow to zero.

Function
Totalizer reset

4.3.18 Sub Menu Pulse Output

This parameter requires special optional equipment and is not presently available with A.52 firmware.

Sub Menu
Pulse Output

4.3.19 Damping

Damping controls the rate at which the unit responds to changes in flow. Without damping, it will show a 100% change in flow in approximately 1 second. By entering various values for damping, the full scale response can be slowed to 100 seconds. This is not a linear function. Response will be faster in the first few seconds of the damping interval than during the last few seconds. Damping is used to smooth out pulsating flow signals that are caused by pumps and to reduce output oscillations that are created by process generated noise.

Use the STEP and DATA keys to make the necessary entries. Then press ENTER.

Damping

Valid Numerical Entries: 1.0 through 100s

4.3.20 Sub Menu Current Output

4.3.20.1 Current Output

Submenu
Current output

Menu Choices: current + pulse *
current + HART

* Pulse decoding is presently not available.

4.3.20.2 I_{out} at Alarm

I_{out} at alarm sets the output current to a low or high value (as selected) in response to Error 5 (EEPROM) or Error 6 (Totalizer) alarm conditions. In case of an operational failure, the computer activates an alarm, an error message is sent to the display, and the current output is determined by the value selected in this menu.

I_{out} at alarm

Valid Numerical Entries: 3.85 mA
22.40 mA

NOTE
The value of the output during the flow-alarms (Error 3 & Error 9) is independent of the selection in this menu and will always be forced to the high-current value.

4.3.21 Sub Menu Display

There are several options available for flow value displays. The first and second lines of the display can be programmed in this menu.

To make an entry, press ENTER and use the arrow keys to scroll through the menu. When the appropriate selection appears, press ENTER.

4.3.21.1 Display 1. line

Select a parameter to be shown on the first line of the LCD display.

display 1. line

Menu Choices: Qv actual flow
 Qm mass flow *
 Qn standard flow **
 Percent
 Bargraph
 Totalizer
 Frequency

where:

Qv = volumetric flow
Qm = mass flow
Qn = standard flow
Percent = Flowrate in the selected flow units as a percent of the selected maximum flowrate (Range max).
Bargraph = as percent, except displayed as a bar and percent
Totalizer = sum of flowrate
Frequency = vortex frequency in Hz measured by the converter

4.3.21.2 Display 2. line

Select a parameter to be shown on the second line of the LCD display.

display 2. line

Menu Choices: Qv actual flow
 Qm mass flow *
 Qn standard flow **
 Percent
 Bargraph
 Totalizer
 Frequency

* Only appears if Mass Flow is selected in "Flow Mode" menu

** Only appears if Standard Flow is selected in "Flow Mode" menu

4.3.22 Sub Menu Self Check

Self Checks are firmware-driven test routines. Use the arrow keys to scroll through the menu

Sub Menu
Self Check

Press enter at this sub-menu to enter its self-test functions:

Function
I_{out}

Press enter at this sub-menu and the "Test I_{out}" display will appear:

Test I_{out}
____ %

A percentage of the output current can be entered up to 115% of the maximum range. The output current will then change to that value.

Note

If a value greater than 115% is entered, an error message is displayed and the output current doesn't enter the self-check mode but remains at its previous value.

Press enter to stop the test.

Function
F_{out}

This parameter is linked to the Pulse Output Sub-Menu (para. 4.3.18) and is not presently available with version A.52 firmware.

Function
HART-Transmitter

Press enter to begin the HART transmitter test mode:

HART Transmitter
0 = pulse

Converter transmits a 2200 Hz (logic 0) signal on the current output lines. Pressing any key will change the output to test the 1200 Hz (logic 1) signal. These signals may be observed by connecting an oscilloscope across a 250 ohm load resistor connected in series with the current output lines.

HART Transmitter
1 = no pulse

Function
HART-Command

Pressing "ENTER" will allow display of the HART command code after a HART test transmission has been sent.

HART-Command
128 Slot 20 *

Asterisk (*) blinks momentarily after each command received. "Slot" indication is only displayed for 128 - 133 Slot commands. For factory test only.

Function
Display

The characters 1234567890ABCDEF are displayed on each display line as a display check.

Function
NVRAM

Self-tests non-volatile RAM

Function
EPROM

Self-tests EPROM

Function
EEPROM

Self-tests EEPROM

4.3.23 Sub Menu Error Register

All error messages and power outages are stored in these registers. The error numbers displayed are a code which identifies the type of error. Refer to Table 4-1.

Sub Menu
Error register

Menu choices: Error Register
 Mains interrupt

4.3.23.1 Error Register

Indicates code numbers of any errors that have occurred since the last time the error register was reset (refer to Table 4-1). The error register can be reset with the Error Reset parameter 4.3.24.4.

Error Register
.....

4.3.23.2 Mains Interrupt

Indicates the number of power outages that have occurred since the last time the unit was turned on. The mains interrupt can be reset with the Error Reset parameter 4.3.24.4.

Mains interrupt
4

Press C/CE to return to the sub-menu.

4.3.24 Code Number

Access to calibration parameters is achieved by entering the proper code number. In order to enter the "**calibration mode**" it is necessary to enter the number "1000". The calibration mode is locked out with the entry of a number other than 1000, after a power-on reset or if no key-entry has been made for ten minutes.

After the correct code number has been entered the program protection (see Section 4.3.2) is automatically turned OFF. Access is terminated if an incorrect code number is entered. Entering an incorrect number will automatically turn program protection ON.

To enter a code number, use the **STEP** or **DATA** keys until the following display appears. Use the **Enter** function then the **STEP** and **DATA** keys to enter the code number (refer to Chapter 3.0 for an explanation of data entry using the push-buttons). For proper security, the code number does not appear on the display as it is entered (asterisks will be displayed).

Code Number

Ten minutes after the last key has been pressed the code number mode **is deactivated and program protection is turned ON.**

The parameters that follow only appear in the Code Number mode.

4.3.24.1 Instrument Number

The instrument number is entered by Bailey-Fischer & Porter. It may be used to uniquely identify an individual meter if several meters are on site. Typically, the last four digits of the unit's Serial Number are entered by the factory but the number may be changed by the user, if desired, using the normal data entry procedure described earlier. The register will accept 8-digits but the instrument number value must be ≤ 65535

Instrument Number

4.3.24.2 Sub Menu k-factor

NOTE
The meter is programmed (configured) by Bailey-Fischer & Porter prior to shipment. Therefore, the meter should not require k-factor adjustment in the field.

The k-factor is the relationship between sensor frequency and volumetric flow rate, and is used to calculate the flowrate at operating conditions. The k-factor is a function of the size of the flowmeter. To maximize accuracy a linearizing algorithm is provided that uses 2, 3, 4, or 5 values. If only one value is required, "Median" is selected. The median k-factor is stamped on the instrument tag and may also be read on the display as described in Section 4.3.7.

The factory-determined k-factors for linearization are listed on a paper label included with the instrument for reference. This is located on the inside of the cover of the signal converter connection box where the STEP, DATA & C/CE push-button switches are located.

To access the k-factor sub-menu, press ENTER and the following display will appear.

Submenu
k-factor

Press ENTER again and the following display appears. Use the arrow keys to make a selection; then press ENTER.

k-Linearization

Menu Choices: 2 points
 3 points
 4 points
 5 points
 Median

If a "points" selection was made refer to Sub-Section 4.3.24.2.1.

If "Median" was selected refer to Sub-Section 4.3.24.2.2

4.3.24.2.1 K-Factor linearization

This menu is available if 2 through 5 point calibration has been selected. It is possible to enter up to 5 calibration values in this menu (over the flowrate range). An interpolation is made between the entered points. First enter frequency f1 and then the corresponding k1 in cycles/m³. Repeat this procedure until all the calibration points (2 through 5) have been entered.

For example:

For 2 points enter the following values:

f1	k1
f2	k2

For 3 points enter the following values:

f1	k1
f2	k2
f3	k3

All frequencies must be less than 2500 Hz. The points must be entered in ascending order; f1 < f2 < f3 < f4 < f5. Use the STEP and DATA keys to make the necessary entries. Then press ENTER. Press C/CE to go to the next parameter.

f 1
100 Hz

Range = 1 - 2500

k 1
1000.0 1/m³

1/m³ represents cycles/m³

Range = 0.0 - 2,000,000

4.3.24.2.2 Median k-factor

This menu is available if Median has been selected in the k-factor menu. The median k-factor stamped on the instrument tag is entered. The k-factor is in cycles/m³. This is a read only parameter. Press C/CE to go to the next parameter.

Median k-factor
1000.0 1/m³

1/m³ represents cycles/m³

Range = 0 - 2,000,000

4.3.24.3 Selectable Meter Range Maximum

This menu allows the option of whether Meter Range Max (see Section 4.3.14) is to be a fixed value or programmable. When **Fixed** is selected, the value of Meter Range Max is determined by the firmware based on meter size and fluid. Selecting **Programmable** allows the numerical Meter Range Max menu parameter to be programmed by the user.

Meter Range Max

Menu Choices: Fixed
Programmable

If **Programmable** is selected, a range value may be entered into the numerical Meter Range Max menu parameter (Section 4.3.14) up to a maximum limit of 1,000,000. The maximum limit is independent of the measurement units selected in the Units Qv menu parameter. The Meter Range Max value entered is also automatically entered as the Range Max value; the Range Min value remains unchanged. The range of values which may be entered for Range Max. remains unchanged at 15% to 115% of Meter Range Max. while the allowable range for Range Min. values stays the same at 0% to 10% of Meter Range Max.

NOTE
If "Programmable" is chosen as the Meter Range Max parameter, the normal Primary, Meter Size and Fluid menu contents are replaced by asterisks (*****) and no menu entry or selection is allowed for those parameters.

4.3.24.4 Function Reset Error

The individual error codes and mains interrupts are stored in the Error Register (Refer to Section 4.3.23) until the reset in this menu is activated by pressing the ENTER key.

Function
Reset error

4.3.24.5 Function Initialize EEPROM

If the display indicates an **Error 5 - EEPROM** periodically, initializing the EEPROM may prevent having to return the meter to the factory for repair. Press ENTER to initialize the EEPROM followed by Reset Error (refer to Section 4.3.24.4) to clear the error indication. **Initializing the EEPROM will require re-entry of some of the stored data.**

Function
Init EEPROM

NOTE
If initialize is selected, several parameters are set to their default values. Make a note of all stored values before initializing the EEPROM since some configuration data must be re-entered following initialization.

4.3.24.6 Function Adjust I_{out} 4 mA

A milliammeter connected in series with the output terminals is required for the output current calibration. Upon selection of Adjust I_{out} 4 mA the converter produces **approximately** 4 mA at the output terminals. The **exact** value of the current is determined with the milliammeter and entered manually using the "STEP" and "DATA" buttons to calibrate the output current. Verify by entering 0% for I_{out} Self Check (refer to 4.3.22).

Function Adjust I _{out} 4 mA
--

4.3.24.7 Function Adjust I_{out} 20 mA

A milliammeter connected in series with the output terminals is required for the current calibration. Upon selection of Adjust I_{out} 20 mA the converter produces **approximately** 20 mA at the output terminals. The **exact** value of the current is determined with the milliammeter and entered manually using the "STEP" and "DATA" buttons to calibrate the output current. Verify by entering 100% for I_{out} Self Check (refer to 4.3.22).

Function Adjust I _{out} 20 mA

4.3.24.8 Function Minimum Current

This test shuts off the 4 - 20 mA current regulating circuitry and displays the current actually being used by the electronics. Under normal conditions and to obtain proper 4 mA regulation, this value should be less than 4 mA.

Function Minimum current

4.3.24.9 Error Code 9

Error code 9 can be turned **ON** or **OFF** using this parameter. When error code 9 is turned **off**, no error message will appear when the flowrate exceeds 115% of Meter Range Maximum (Section 4.3.14). When Error Code 9 is turned **on**, an error indication will appear in the error register (Section 4.3.23.1) and the output current will be forced to 22.4 mA regardless of the I_{out} at Alarm setting selected in Section 4.3.20.2. This is a "latching" alarm that is **not** self-resetting. If the cause of the alarm condition is corrected, the error code may be reset by pressing any button on the keypad. This alarm is independent of the "Range Maximum" setting in Section 4.3.15.

Error 9 off

Menu Choices: on
 off

If Meter Range Maximum is made "programmable" (as described in Section 4.3.24.3), the Error 9 alarm is still referenced to the "fixed" Meter Range Max value resident in the firmware and occurs (if enabled) at 115% of this value, as before. It will **not** occur at 115% of the "user programmed" value entered in Section 4.3.14 if "programmable" is selected in Section 4.3.24.3.

4.4 Analog Board Switches

The switches on the Analog Board customize the sensor signal noise filter characteristics to the meter size and process fluid. It is important that these switches be set correctly for proper operation of the meter. The switches are generally preset at the factory and should require no re-adjustment but if a verification of the proper settings is desired, Table 4-3 on the next page correlates the filter switch positions with the applicable meter size and process fluid.

Figures 2-6 and 4-3, below, show the location of the switches on the Analog Board Assembly. The Analog Board is located in the signal converter electronics housing. The cover of the electronics housing must be removed by removing the four bolts in order to gain access to the Analog Board Assembly.

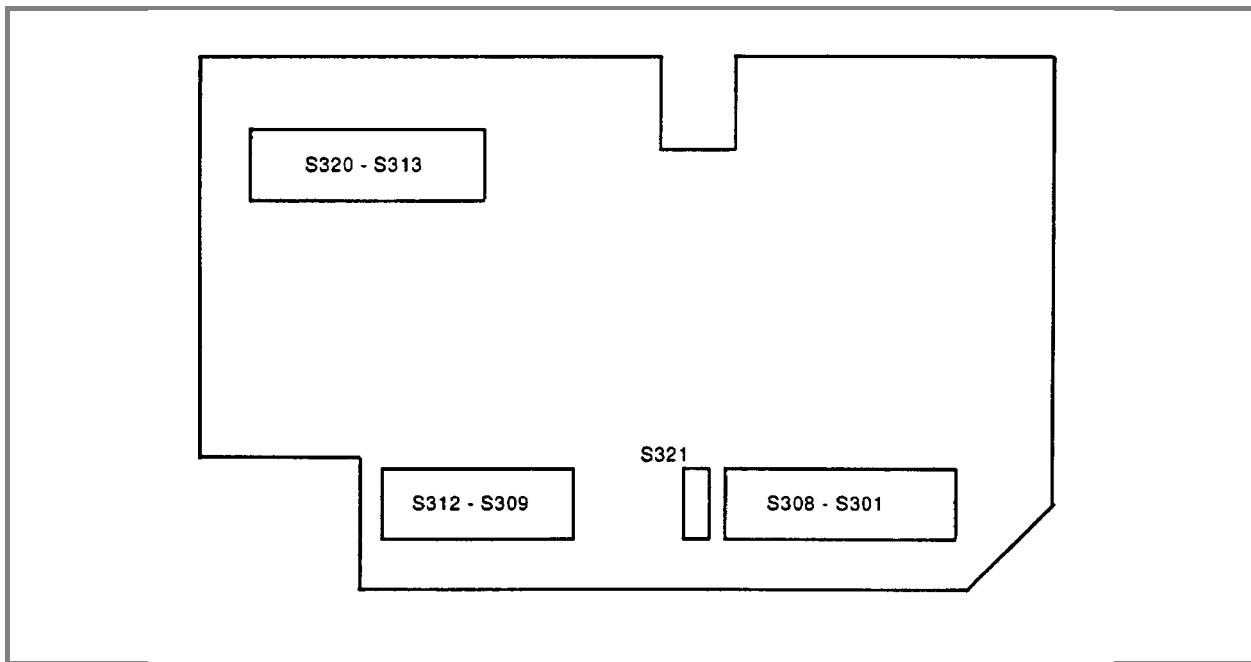

FIGURE 4-3. ANALOG BOARD SWITCH LOCATIONS

Medium	Meter Size		SWITCHES TO BE IN CLOSED OR "ON" POSITION (ALL OTHER SWITCHES MUST BE OPEN)																					
	in.	mm	S301	S302	S303	S304	S305	S306	S307	S308	S309	S310	S311	S312	S313	S314	S315	S316	S317	S318	S319	S320	S321	
Gas	.75	20	•	•			•	•			•					•								
	1	25	•	•			•	•			•					•								
	1.25	32	•	•			•	•			•					•								
	2	50	•	•			•	•			•					•								
	3	80		•								•					•							
	4	100			•					•		•					•							
	6	150			•					•			•					•					•	
	8	200				•				•			•					•					•	
	12	300				•				•			•					•					•	
	16	400				•				•			•							•			•	
Liquid	.75	20				•				•				•					•				•	
	1	25				•				•				•					•				•	
	1.25	32				•				•				•						•			•	
	2	50				•				•				•						•			•	
	3	80		•	•	•			•	•	•			•					•	•			•	
	4	100		•	•	•			•	•	•	•	•	•							•		•	
	6	150		•	•	•			•	•	•	•	•	•	•	•	•	•	•	•	•	•		•
	8	200		•	•	•			•	•	•	•	•	•	•	•	•	•	•	•	•	•		•
	12	300		•	•	•			•	•	•	•	•	•	•	•	•	•	•	•	•	•		•
	16	400		•	•	•			•	•	•	•	•	•	•	•	•	•	•	•	•	•		•

NOTE: • indicates switch to be in "closed" or "ON" position

TABLE 4-3. ANALOG BOARD FILTER SWITCH SETTINGS

5.0 TROUBLESHOOTING AND FLOW RATE TABLES

WARNING
 All Flowmeters and/or Signal Converters being returned to Bailey-Fischer & Porter for repair must be free of any hazardous materials (acids, alkalis, solvents, etc.). A Material Safety Data Sheet (MSDS) for all process liquids must accompany returned equipment.

5.1 Troubleshooting

Problem	Corrective Action
A. No indication on display when power is applied.	<ol style="list-style-type: none"> 1. Check connections to terminal block. 2. Check for dc voltage at terminal block. 3. Check polarity of power leads. 4. Check that the 5-pin analog board connector 3x4 is properly secured and plugged into the digital board connector 2x4.
B. No flow indication when flow exists through meter.	<ol style="list-style-type: none"> 1. Verify that programming switches S301 through S321 are set correctly for the meter size and fluid (refer to Sections 2.6 & 4.4). 2. Verify that all menu parameters are entered correctly. 3. Check that flow is not below the meter's minimum range setting. 4. Using the Display Sub Menu Parameter 4.3.21, configure one line of the display to indicate "Frequency". <ol style="list-style-type: none"> a) If sensor frequency is displayed, meter is defective and must be returned to Bailey-Fischer & Porter for repair. b) If no sensor frequency is displayed: <ol style="list-style-type: none"> (1) Check that the 5-pin analog board connector 3x4 is properly secured and plugged into the digital board connector 2x4. (2) Check that the sensor leads are properly secured to the analog board terminal block 3x5 pins 19 and 2B. (3) If sensor leads are properly secured, remove sensor leads from terminal block 3x5 and (if available) connect sine-wave generator leads to terminal block. Using an oscilloscope, set sine-wave generator output voltage to approximately 100 mV P-P and signal frequency to 40 Hz for liquid meters and 300 Hz for gas meters. If display shows sine-wave generator frequency and flow indication, sensor is defective and must be replaced.
C. Flow indication on display when no flow exists	<ol style="list-style-type: none"> 1. Using the Display Sub Menu Parameter 4.3.21, configure one line of the display to indicate "Frequency". 2. If display indicates power-line frequency (usually 60Hz in US), check that meter body & pipeline are properly grounded. 3. If properly grounded and problem persists, try reversing sensor leads at 3x5 terminal block terminals 2B & 19 on Analog Board (Refer to Figure 2-6). 4. Check to make sure that there is less than 15 VAC "common-mode" voltage between meter body and DC power supply
D. Low or High flow reading on display	<ol style="list-style-type: none"> 1. Check values of k-factor(s) entered. 2. Check value of meter size. 3. Check that process fluid, liquid or gas, has been selected correctly.
E. Erratic or jumpy display	<p>May be overly sensitive to process flow variations or characteristics. Try increasing the Damping value (Section 4.3.19) to decrease response time.</p>

10ST1000 SWIRLMETER INSTRUCTION BULLETIN

<p>F. "Error 3 - Flow > 115%" occurs</p>	<p>Process flowrate exceeds Range Max. setting (Refer to Section 4.3.15)</p> <ol style="list-style-type: none"> 1. Process flowrate too high. Reduce flowrate or increase Range Max. value and alarm will self-reset. 2. Process flowrate may be exceeding meter's parameters. Check that Range Max., meter size, medium, type, etc. are all set correctly. 3. Check all k-factors as discussed in Section 4.3.24.2. Make certain that k1 through k5 have been entered correctly and are the correct values according to the label inside the connection box cover which lists the proper values for k1 through k5. If linearization is being used, make sure none have been set to "0".
<p>G. "Error 5 - EEPROM" appears</p>	<p>Data error has occurred in EEPROM.</p> <ol style="list-style-type: none"> 1. Perform EEPROM Self-Check (See Section 4.3.22). 2. If self-check is "OK", re-initialize EEPROM (Refer to Section 4.3.24.5) 3. If self-check fails, meter must be returned to factory for repair
<p>H. "Error 6 - Totalizer" appears</p>	<p>Two Totalizer values stored in the instrument don't match.</p> <ol style="list-style-type: none"> 1. Reset Totalizer (Refer to Section 4.3.17.4) and start totalizing from zero
<p>I. "Error 9 - $Q_v > 115\% Q_{max DN}$" appears</p>	<p>Process flow exceeds 115% of Meter Range Max.</p> <ol style="list-style-type: none"> 1. Process flowrate too high. Reduce flowrate and press any push-button key to reset when flowrate has been reduced. 2. Process flowrate may be exceeding meter's parameters. Check that meter size, medium, type, etc. are all set correctly. 3. Check all k-factors as discussed in Section 4.3.24.2. Make certain that k1 through k5 have been entered correctly and are the correct values according to the label inside the connection box cover which lists the proper values for k1 through k5. If linearization is being used, make sure none have been set to "0".
<p>J. "Error 9" keeps reoccurring</p>	<p>Surges in the process flow may be triggering the alarm. Try increasing the Damping value (Section 4.3.19) to slow the response time.</p>
<p>K. Problems with HART reception or transmission</p>	<ol style="list-style-type: none"> 1. Make sure that "Current + HART" is selected in Current Output sub-menu (Section 4.3.20). 2. Check that the value of the load resistance in series with the current output is between 250 and 500 ohms. 3. For HART reception problems, perform the "HART-Command" test in the Self Check sub-menu (Section 4.3.22). 4. For HART transmission problems, perform the "HART-Transmitter" test in the Self Check sub-menu (Section 4.3.22).
<p>L. Moisture is found inside electronics housing</p>	<p>Some small amount of condensation may be normal if there is a large temperature differential between inside & outside of housing. If moisture is excessive, housing gaskets in the housing covers may be damaged or not seated properly or the covers may not be tightened properly.</p> <ol style="list-style-type: none"> 1. Remove housing and/or connection box covers and inspect O-ring gaskets. If damaged, contact factory for replacements. 2. If not seated properly, correct the problem and carefully re-install the covers, making sure screws are properly tightened.

5.2 Flow Rates and Frequencies

Information in the following tables is provided to support troubleshooting of the instrument.

TABLE 5-1. WATER FLOW RATES AND FREQUENCIES

Meter Size (inches)	K-Factor (nominal)	Flow Rate Limits (GPM)		Signal Frequency (Hz)	
		Minimum	Maximum	Minimum	Maximum
.75	170000	1	9	11	97
1	85000	2	27	11	145
1.25	34000	4	44	9	94
2	12000	11	110	8	83
3	2800	15	440	3	78
4	1650	22	660	2	69
6	440	66	1629	1.83	45
8	190	110	2200	1.32	26
12	60	440	4403	1.67	17
16	25	793	7925	1.25	12

TABLE 5-2. AIR FLOW RATES AND FREQUENCIES

Meter Size (inches)	K-Factor (nominal)	Flow Rate Limits (ACFH)		Signal Frequency (Hz)	
		Minimum	Maximum	Minimum	Maximum
.75	170000	88	883	118	1181
1	85000	177	1766	118	1181
1.25	34000	248	4591	66	1228
2	12000	636	12360	60	1167
3	2800	1410	30018	31	661
4	1650	2295	52973	30	688
6	440	4237	127132	18	440
8	190	7063	176575	11	264
12	60	14126	353150	7	167
16	25	35315	706300	7	139

TABLE 5-3. CONVERSION FACTORS

1 m ³ = 264.2 gallons
1 m ³ = 35.31 ft ³
1 gallon H ₂ O = 8.345 lbs
1 ft ³ H ₂ O = 62.42 lbs
Density of Air = 0.0749 lb/ft ³ @ 14.7 psia & 70°F

NOTE:

If meter is diagnosed as being defective and only the electronics (without the meter body) are being returned to the factory for repair or replacement, the following is an important procedure that should be performed prior to returning the electronics for repair.

The Analog Board (the PC board with the programming switches) contains a potentiometer (R312) to establish the signal "gain" or amplification value of the preamplifier circuitry. R312 is **calibrated at the factory under controlled flow conditions** to provide the optimum performance for the flowmeter in sensing the flow signal. If the meter's electronics are being returned to the factory for repair or replacement, a record should be kept of the value of this potentiometer setting. This allows establishing the same parameters when the equipment is returned and meter operation is restored.

To establish the calibrated value of R312, use the following procedure:

- Turn off power to the instrument.
- Remove the larger windowed top cover of the electronics compartment by removing the four bolts in the corners.
- Locate the Analog Board near the digital display of the lower Digital Board (The Analog Board contains the three banks of programming switches referenced in Sections 2.6 & 4.4).
- Locate potentiometer R312 on the Analog Board (It should be a blue or gray rectangular component with a small adjustment screw facing upward and is located in the left half of the board, about midway between top and bottom edges - Refer to Figure 2-6).
- Using a small fine-bladed screwdriver that fits the potentiometer's adjustment screw, turn the screw **counterclockwise** while counting the number of **full turns** made until a **faint clicking** is heard. This indicates the end of the potentiometer's adjustment range.
- Record the number of turns required to reach the end of R312's adjustment range (until the clicking is heard).

When the **replacement*** electronics are received and operation is to be restored, use the following procedure:

- Make certain power to the instrument is **OFF**.
- Make certain that potentiometer R312 is adjusted to its starting point by turning the adjusting screw fully counterclockwise several turns until the faint clicking is heard.
- Adjust R312's adjustment screw **clockwise** until the number of turns recorded in the above procedure is reached. This will insure that the operating conditions have been restored to their previous values.
- Replace the cover(s) for the instrument.
- Re-apply power to the meter.

*If a totally **new meter** is received as a replacement (meter body and electronics), is not necessary to perform this procedure since the meter will have been calibrated at the factory before shipment.

6.0 PARTS LIST

The following pages show a cutaway view of the flowmeter that indicates replacement parts that are available for the meter along with their Bailey-Fischer & Porter ordering numbers.

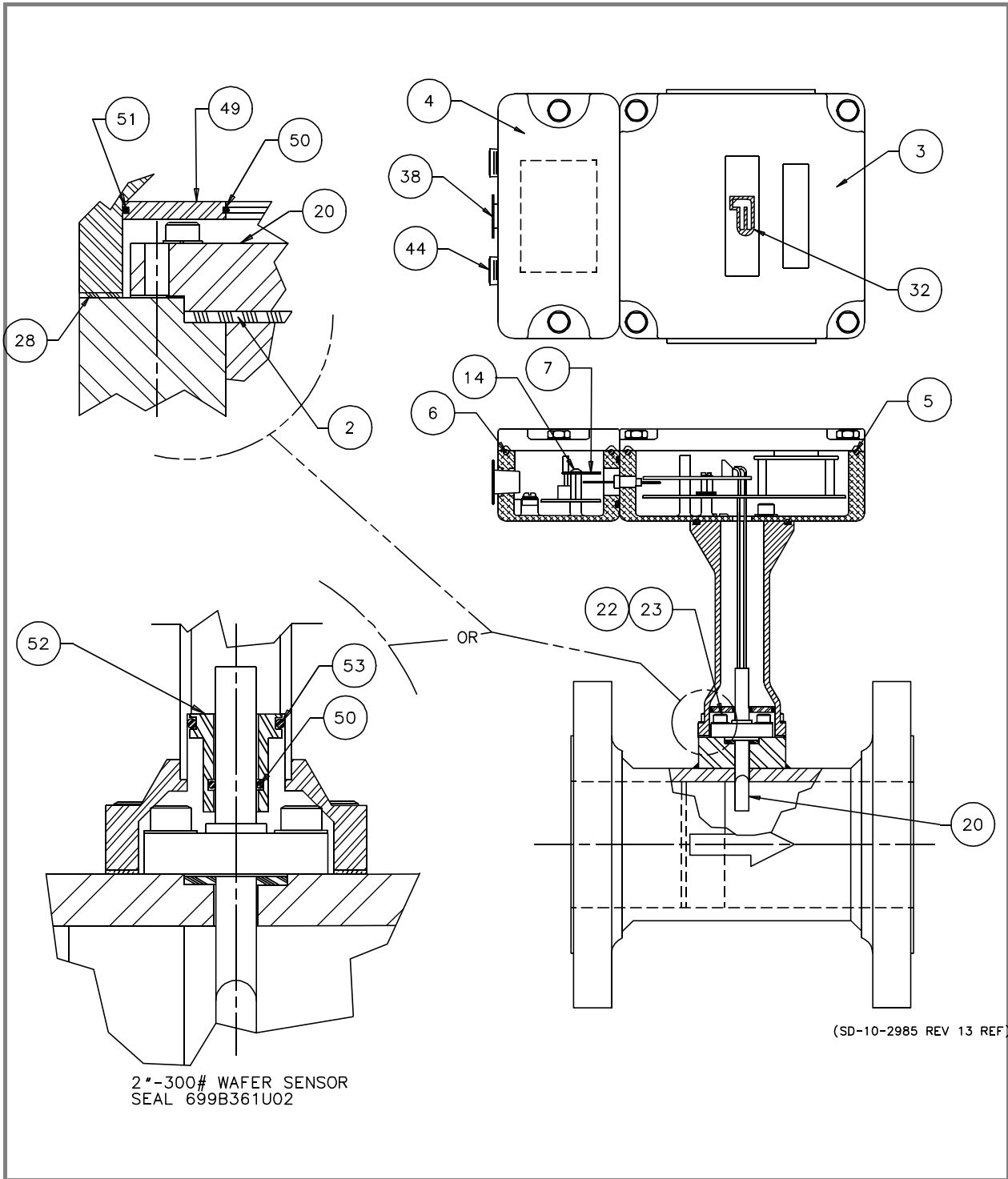

NOTE: The meter body shown is different from the Swirlmeter body but this does not affect the Replacement Parts List shown in Table 6-1.

FIGURE 6-1. FLOWMETER/SIGNAL CONVERTER PARTS
(Refer to Table 6-1 for ordering information.)

TABLE 6-1. FLOWMETER / SIGNAL CONVERTER PARTS LIST

Refer to Figure 6-1 for location of key numbers.

2	D101K002U01 101W709U01 D101C001U01	Sensor O-Ring Seal, KALREZ " , VITON " , TEFLON
3	D612A104U01	Cover w/ Window & Screws
4	D379D024U02	Connection Box Cover w/ Screws
5	D101A009U01	Gasket, Electronics Box
6	D333F004U01	Gasket, Connection Box
7	D355H162U04	STEP/DATA ID Plate
14	1D107B1004	Rivet
17	85D027AU20	6 mm Washer
18	22J112AU20	M6x16 Screw
20	D693B015U03 D693B017U03	Sensor Assembly, 3/4 - 8 in. Sensor Assembly, 12 & 16 in.
22	09H112AU20	M5x16 Screw
23	85C024EU20	M5 Lockwasher
28	333G231U01	Gasket
32	D338A006U02	B-F&P Monogram
38	114B081U03	Tapered Pipe Plug
44	112A352U22	Hex Socket Pipe Plug
49	374A162U01	Sensor Seal
50	101S706U01	O-Ring, Silicone (-011)
51	101S916U01	O-Ring, Silicone (-028)
52	374A162U02	Sensor Seal, 2"-300LB Wafer
53	101S903U01	O-Ring, Silicone, 2"-300LB Wafer

TABLE 6-2. FLANGE GASKETS

Meter Size		ANSI Flange Rating	Gasket Part No. (2) required
inches	mm		
.75	20	150	333J083U66
		300	333J083U67
1	25	150	333J089U10
		300	333J089U11
1.25	32	150	333J083U68
		300	333J083U69
2	50	150	333J089U19
		300	333J089U25
3	80	150	333J089U22
		300	333J089U26
4	100	150	333J089U29
		300	333J089U30
6	150	150	333J083U33
		300	333J083U42
8	200	150	333J083U38
		300	333J083U46
12	300	150	N/A
		300	N/A
16	400	150	N/A
		300	N/A

N/A = not available



DOCUMENTATION QUESTIONNAIRE

Your answers to the questions below and other comments assist us in publishing better documentation. If an answer requires explanation please use the space provided. All comments and suggestions become the property of Eltag Bailey Process Automation.

1. Title of Document? **IB 10ST1000 - Rev. 1, PN 24793** _____

2. Does this document meet your needs? _____

3. Is the information:

Easily understandable? _____

Properly organized? _____

Complete? _____

Sufficiently illustrated? _____

OTHER COMMENTS

(Please include page and/or figure number.)

Name _____

Address _____

No postage necessary
if mailed in the U.S.A.

If Bailey employee, please include
department number.

CUT ALONG LINE, FOLD, STAPLE



FOLD 1



NO POSTAGE
NECESSARY
IF MAILED
IN THE
UNITED STATES

BUSINESS REPLY MAIL

FIRST CLASS PERMIT NO. 86 WARMINSTER, PA

POSTAGE WILL BE PAID BY ADDRESSEE:

**BAILEY-FISCHER & PORTER
DEPARTMENT 261 / A2
125 EAST COUNTY LINE ROAD
WARMINSTER, PA 18974**

Attention: Technical Publications

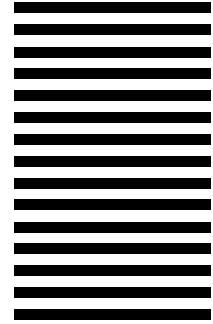

FOLD 2

STAPLE
HERE

Our more than 6,000 professionals worldwide are ready to meet your needs for Strategic Enterprise Management...

Bailey

Australia

Elsag Bailey Pty. Limited
Regents Park, NSW
Telephone: 61-2-645-3322
Telefax: 61-2-645-2212

Belgium

Bailey-Fischer & Porter NV
Wilrijk
Telephone: 32-3-828-05-11
Telefax: 32-3-827-87-28

Brazil

Bailey do Brasil
São Paulo
Telephone: 55-11-548-4122
Telefax: 55-11-547-0315

Canada

Elsag Bailey (Canada), Inc.
Burlington, Ontario
Telephone: 1-905-639-8840
Telefax: 1-905-639-8639

China

Bailey Beijing Controls
Beijing
Telephone: 86-10-401-0651
Telefax: 86-10-401-1643

Finland

Bailey-Fischer & Porter OY
Espoo
Telephone: 358-0-859-3133
Telefax: 358-0-859-3324

France

Elsag Bailey SA
Massy
Telephone: 33-1-64-47-2000
Telefax: 33-1-64-47-2016

Germany

Bailey-F & P Automation GmbH
Overath
Telephone: 49-220-473-90
Telefax: 49-220-473-979

Bailey-Fischer & Porter GmbH

Göttingen
Telephone: 49-551-905-0
Telefax: 49-551-905-777

Italy

Elsag Bailey
Genoa
Telephone: 39-10-658-1
Telefax: 39-10-658-2941

Italy

Fischer & Porter Division
Milan
Telephone: 39-2-927-71
Telefax: 39-2-923-1257

Japan

Bailey Japan Company, Ltd.
Tagata-Gun, Shizuoka-Ken
Telephone: 81-559-49-3311
Telefax: 81-559-49-1114

Jordan

Bailey Controls Jordan
Amman
Telephone: 962-6-788-116
Telefax: 962-6-756-908

Mexico

Bailey Mexico SA de CV
Naucalpan
Telephone: 52-5-557-6100
Telefax: 52-5-557-7022

Netherlands

Bailey-Fischer & Porter Nederland BV
Gorinchem
Telephone: 31-183-69-1111
Telefax: 31-183-69-1177

Norway

Bailey Norge AS
Bergen
Telephone: 47-55-222-000
Telefax: 47-55-222-010

Russia

Bailey Avtomatizatsiya
Moscow
Telephone: 7-502-224-8130
Telefax: 7-502-224-8145

Singapore

Elsag Bailey Pte. Ltd.
Singapore
Telephone: 65-442-3200
Telefax: 65-442-2700

Spain

Bailey-Fischer & Porter España SA
Madrid
Telephone: 34-1-415-2200
Telefax: 34-1-415-3950

Sweden

Bailey-Fischer & Porter Sverige AB
Stockholm
Telephone: 46-8-601-2850
Telefax: 46-8-601-2860

United Kingdom

Bailey Automation plc
Telford, Shropshire
Telephone: 44-1952-670-477
Telefax: 44-1952-670-455

Fischer & Porter Ltd.

Workington, Cumbria
Telephone: 44-1946-830-611
Telefax: 44-1946-833-003

United States

Bailey Controls Company
Wickliffe, Ohio
Telephone: 1-216-585-8500
Telefax: 1-216-585-8756

Bailey-Fischer & Porter Company

Warminster, Pennsylvania
Telephone: 1-215-674-6000
Telefax: 1-215-674-7183

Venezuela

Bailey de Venezuela SA
Valencia
Telephone: 58-41-329-196
Telefax: 58-41-327-632

Turbine Control Systems

Electronic Technology Systems, Inc.
New Kensington, Pennsylvania USA
Telephone: 1-412-335-1300
Telefax: 1-412-335-2450

Energy Management & SCADA Systems

Bailey Network Management
Sugar Land, Texas USA
Telephone: 1-713-274-5000
Telefax: 1-713-240-6986

Liquid Analysis Products

TBI-Bailey Controls
Carson City, Nevada USA
Telephone: 1-702-883-4366
Telefax: 1-702-883-4373

On-Line Process Analysis

Fluid Data, Inc.
Angleton, Texas USA
Telephone: 1-409-849-2344
Telefax: 1-409-849-2166

BAILEY
FISCHER
PORTER

TBI-Bailey



Bailey
Network Management

FLUID
DATA