

Operating Instructions
FOUNDATION fieldbus

pH and ORP/Redox Transmitters
Model TB82PH

IndustrialIT
enabled™



ABB Incorporated

The Company

ABB Incorporated is an established world force in the design and manufacture of instrumentation for industrial process control, flow measurement, gas and liquid analysis and environmental applications.

As a part of ABB, a leader in process automation technology, we offer customers application expertise, service and support worldwide.

We are committed to teamwork, high quality manufacturing, advanced technology and unrivalled service and support.

The quality, accuracy and performance of the Company's products result from over 100 years experience, combined with a continuous program of innovative design and development to incorporate the latest technology.

ISO 9001:2000



Reno, Nevada USA Facility
Cert. No. CERT-9170-2003-AQ-HOU-RAB

Use of Instructions



Warning.

An instruction that draws attention to the risk of injury or death.



Note.

Clarification of an instruction or additional information.



Caution.

An instruction that draws attention to the risk of damage to the product, process or surroundings.



Information.

Further reference for more detailed information or technical details.

Although **Warning** hazards are related to personal injury, and **Caution** hazards are associated with equipment or property damage, it must be understood that operation of damaged equipment could, under certain operational conditions, result in degraded process system performance leading to personal injury or death. Therefore, comply fully with all **Warning** and **Caution** notices.

Information in this manual is intended only to assist our customers in the efficient operation of our equipment. Use of this manual for any other purpose is specifically prohibited and its contents are not to be reproduced in full or part without prior approval of Technical Communications Department, ABB Automation.

Health and Safety

To ensure that our products are safe and without risk to health, the following points must be noted:

1. The relevant sections of these instructions must be read carefully before proceeding.
2. Warning labels on containers and packages must be observed.
3. Installation, operation, maintenance and servicing must only be carried out by suitably trained personnel and in accordance with the information given.
4. Normal safety precautions must be taken to avoid the possibility of an accident occurring when operating in conditions of high pressure and/or temperature.
5. Chemicals must be stored away from heat, protected from temperature extremes and powders kept dry. Normal safe handling procedures must be used.
6. When disposing of chemicals ensure that no two chemicals are mixed.

Safety advice concerning the use of the equipment described in this manual or any relevant hazard data sheets (where applicable) may be obtained from the Company address on the back cover, together with servicing and spares information.

CONTENTS

Section	Page
CONTENTS	3
INTRODUCTION.....	3
SUPPLEMENTARY DOCUMENTATION.....	3
TRANSPORT	4
STORAGE	4
HANDLING	4
PRODUCT IDENTIFICATION	4
PRINCIPLE OF OPERATION	5
INSTALLATION.....	7
ELECTRICAL CONNECTIONS.....	8
LOCAL HMI OPERATING PROCEDURES	10
MEASURE MODE.....	11
CALIBRATE MODE.....	11
Process Variable Calibrate State	11
Temperature Calibrate State.....	12
Edit Calibrate State	13
Reset Calibrate State	13
OUTPUT/HOLD MODE.....	14
CONFIGURE MODE	14
Analyzer State.....	15
Temperature Sensor State.....	16
Temperature Compensation State	16
Linearity Type State	17
Diagnostic State.....	17
SECURITY MODE.....	18
SECONDARY DISPLAY MODE.....	18
UTILITY MODE	19
Reset Configuration State	19
Reset Security State	19
Reset All State	19
Reset Software State	19
Transmitter Identification (FF.ID) State	20
Damping State	20
TRANSMITTER'S FIELDBUS FUNCTIONALITY.....	20
DEVICE BLOCKS	22
HARDWARE DIP SWITCH FUNCTIONS	37
SIMPLE FAULT FINDING.....	38
DIAGNOSTIC INFORMATION.....	39
Calibration Diagnostic Messages	41
Additional Diagnostic Messages	41
SENSOR TROUBLESHOOTING	41
Visual Sensor Inspection.....	41
Sensor Electronic Test	42
DIAGNOSTIC INFORMATION RECEIVED FROM THE FIELDBUS	43
DISMANTLING AND REASSEMBLY.....	46
SPECIFICATIONS	47
GLOSSARY OF PROGRAMMING TEXT PROMPTS	50
PRODUCTS & CUSTOMER SUPPORT.....	53
Analytical Instrumentation	53
Controllers & Recorders.....	53
Flow Metering.....	53
Level Control	53
Pneumatic Instrumentation	53

INTRODUCTION

The **TB82PH pH/ORP/pION FOUNDATION Fieldbus (FF) Transmitters** are a modular range of field mounted, microprocessor-based instruments. Accurate and reliable measurement of pH, ORP (Oxidation-Reduction Potential) and pION (specific ion) parameters is provided, in the even most difficult and hazardous industrial environments.

The TB82 family of transmitters offers Analog (4-20 mA output), Analog with HART digital communication, Profibus PA, and FOUNDATION Fieldbus product versions.

This manual describes the features, installation requirements, configuration commissioning, and calibration procedures related to the TB82PH pH/ORP/pION FF Transmitter.

The delivery of the TB82PH FF device includes the Device Description and Capability files.

Refer to the supplementary documentation section to obtain additional information on the FOUNDATION Fieldbus communication protocol and device installation.

SUPPLEMENTARY DOCUMENTATION

Reference information on FOUNDATION Fieldbus design and structure can be found in the following documents:

- Document 30 Fb 10 Fieldbus Solutions from ABB - Technical brochure
- IEC 61158-2 Fieldbus standard for use in industrial control systems – Part 2: Physical Layer specification and service definition
- FD-140 31.25 kbit/s Wiring and Installation Guide
- FF-801 Network Management Specification
- FF-800 System Management Specification
- FF-821 Data Link Layer Services Subset Specification
- FF-822 Data Link Layer Protocol Subset Specification
- FF-875 Fieldbus Access Sub-layer Specification
- FF-870 Fieldbus Message Specification
- FF-890 Function Blocks
- FF-891 Function Blocks - Part 2 specification
- FF-892 Function Blocks - Part 3 specification

Visit the internet site for online/up-to-date information: www.abb.com or www.fieldbus.org

TRANSPORT

After factory calibration, the instrument is packed in a carton, intended to provide protection from physical damage.

STORAGE

The instrument does not require any special treatment if stored as dispatched and within the specified ambient conditions level listed in the Specification section. There is no limit to the storage period.

HANDLING

The instrument does not require any special precautions during handling, though care should be observed.

PRODUCT IDENTIFICATION

The following data plates shown in Figure 1 identify the instrument.

The Nameplate (Reference A) provides information concerning the product identity code (i.e., nomenclature), product name, operating voltage range, output type, serial number, test personnel badge number, and dielectric strength verification stamp.

The Agency Approval label (Reference B) is included when the transmitter is purchased for compliance with hazardous area regulations (e.g., intrinsic safety protection) for a specific country (e.g., CSA, FM, or CENELEC).

EC conformance is identified using a CE label (Reference C). Optional tagging specified by customer requirements is provided via a supplementary tag (Reference D).

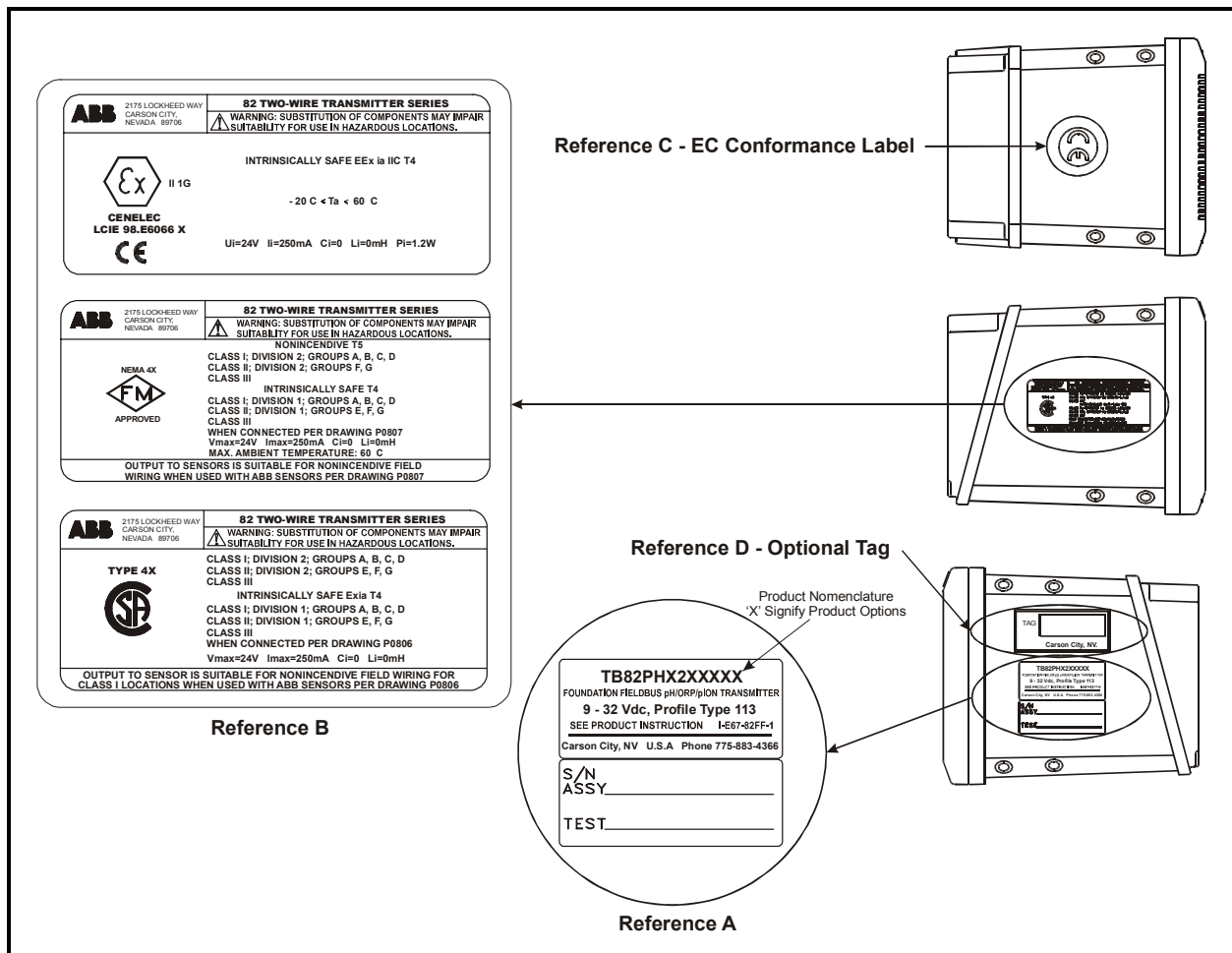

Figure 1 – Product Identification

PRINCIPLE OF OPERATION

The TB82PH pH/ORP/pION FOUNDATION Fieldbus Transmitter provides on-line measurement of liquid properties in industrial environments using an advanced microprocessor-based technology. Transmitter power and digital communication based on the FOUNDATION Fieldbus protocol is provided by fieldbus wiring. The TB82PH transmitter can be installed indoors or outside due to its IP65 and NEMA 4X environmental enclosure ratings. Cable glands for field wiring ensure adequate sealing barriers to ambient conditions while maintaining the environmental ratings of the transmitter.

The Human Machine Interface (HMI), shown in Figure 2, consists of a tactile keypad having four universal keys, one hidden key, and a custom LCD. The LCD has a three and one-half digit numeric region that displays the process variable, a six-digit alphanumeric region that displays secondary information and programming prompts, and several status-indicating and programming icons. Each of the four universal keys is located under a set of icons. In each of the instrument modes and states, one icon over a given key will be illuminated and will represent that key's function. These assignments vary and depend upon the programming mode or state the transmitter is currently occupying. In addition to the key assignments, text strings located in the six character alphanumeric field are used as programming prompts.

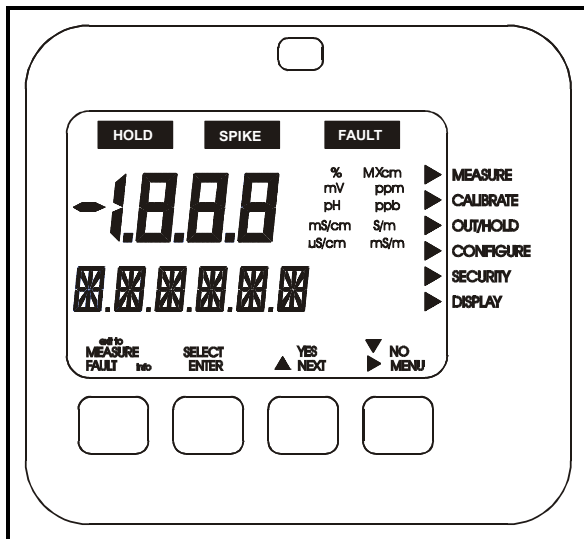

Figure 2 – TB82PH HMI

The signal conditioning circuitry contained in the transmitter is designed to process the high-impedance, galvanic signal generated by glass electrode pH sensors. This circuit processes the sensor signal into a format that is transferred to a secondary circuit. The secondary circuit uses a microprocessor to compute the precise primary

variable compensating for the combined effects of circuit tolerances, sensor calibration information, and temperature effects. Permanent memory stores transmitter and sensor specific information such as:

- Non-modifiable data such as the serial number, the UID (Unique Identifier), the manufacturer's name and device type, the hardware and software version of the electronics.
- Modifiable data such as transmitter configuration information, sensor calibration data, and security passwords.

The sensor and all electronic parts are galvanically isolated from the transmitter body. This isolation is verified at the factory using a Dielectric Strength Test.

The instrument consists of three functional circuits that have been divided into three unique Printed Circuit Board (PCB) assemblies:

- Signal Conditioning Input Assembly
- Microprocessor/Display Assembly
- Power Supply/Communication Assembly

A block diagram representing the electronic functional areas is shown in Figure 3. The flow of information starts from the sensor input and moves through the transmitter to the FOUNDATION Fieldbus interface that produces a digital signal compliant with FOUNDATION Fieldbus specification (IEC-61158-2 - see Supplementary Documentation). The digital communication and HMI capabilities provide for remote or local access to transmitter parameters for configuration and maintenance operations.

The fieldbus furnishes transmitter power and can be configured as a point-to-point, tree, Daisy Chain, or Trunk/Spurs network. Modulating the base quiescent current generates the communication signals. The quiescent current value is used as a reference in order to establish the number of devices that can be installed on a single bus line.

Data is transmitted over the bus using the digital, bit-synchronous Manchester II coding at a baud rate of 31.25 kbit/sec. Figure 4 shows an example of a typical bus configuration using ABB's FIO100 interface module.

... PRINCIPLE OF OPERATION

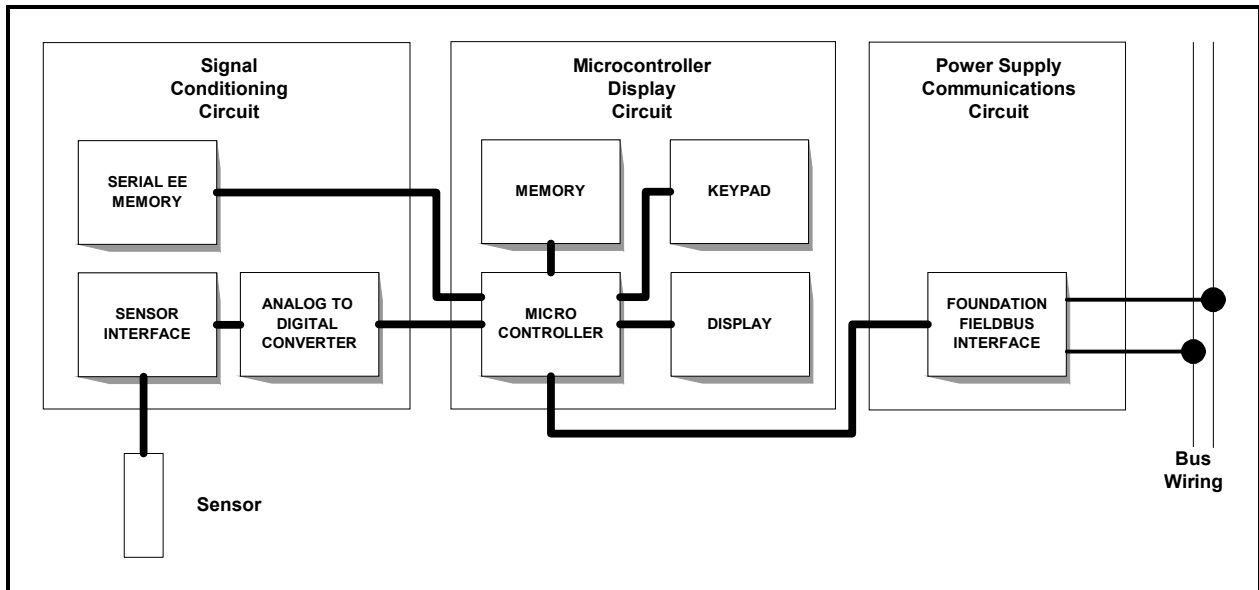

Figure 3 – Functional Block Diagram for FOUNDATION Fieldbus

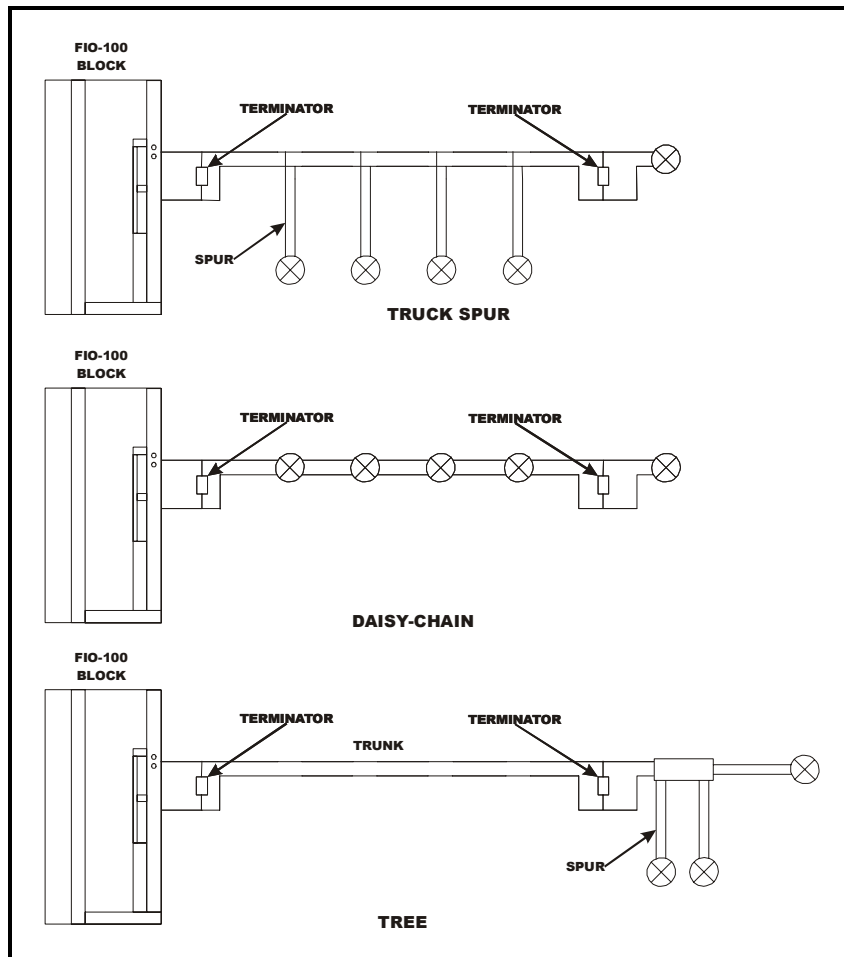

Figure 4 – Typical Bus Configurations

INSTALLATION

Besides the normal precautions for storage and handling of electronic equipment, the transmitter contains static sensitive devices. Since semiconductors can be damaged by the direct discharge of static electricity, avoid contact with terminal block conductors and electronic components on the circuit board.

When mounting the transmitter, choose a location that has ample clearance for the removal of the front bezel and rear cover. The location should provide easy access for maintenance procedures and not be in a highly corrosive environment. Excessive mechanical vibrations and shocks as well as relay and power switches should not be in the immediate area. Signal wiring should not be placed in conduit or open trays that contain power wiring for heavy electrical equipment. Field wiring should meet wiring practices appropriate for fieldbus devices (See Supplementary Documentation).

The transmitter can be pipe, hinge, wall or panel mounted. Use the appropriate figure below to assist in the mechanical installation of the transmitter.

Warning.
 For installation in Hazardous Areas, i.e. areas with danger of fire and/or explosion, irrespective of the protection mode used, the installation must be carried out in accordance with local authority regulations. Ensure also that the temperature of the transmitter does not exceed the value indicated in the Safety Marking plate.

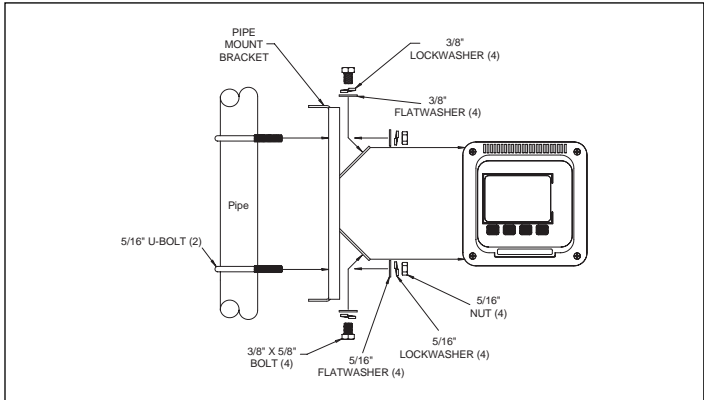

Figure 5 – Pipe Mounting Detail

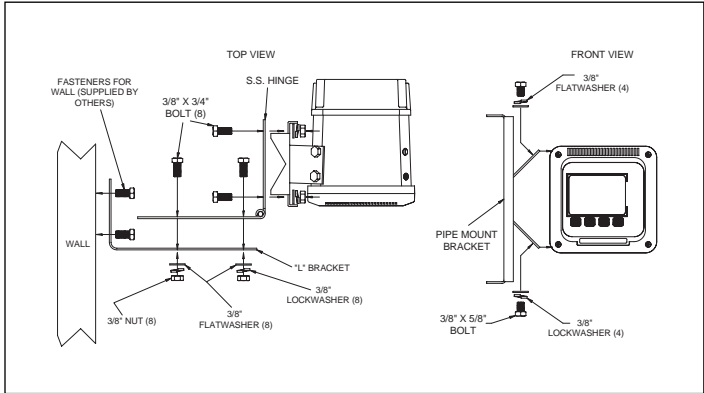

Figure 6 – Hinge Mounting Detail

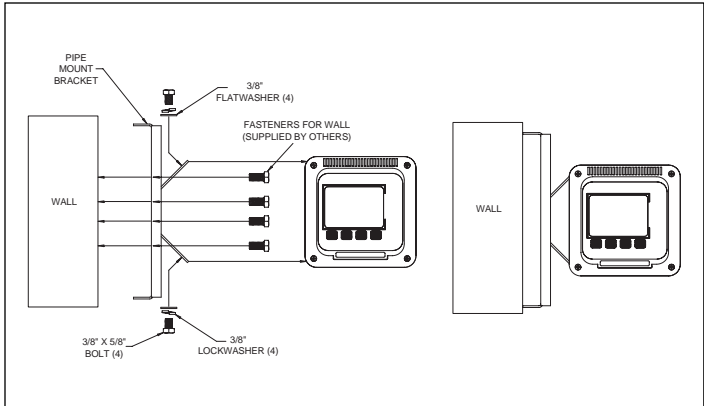

Figure 7 – Wall Mounting Detail

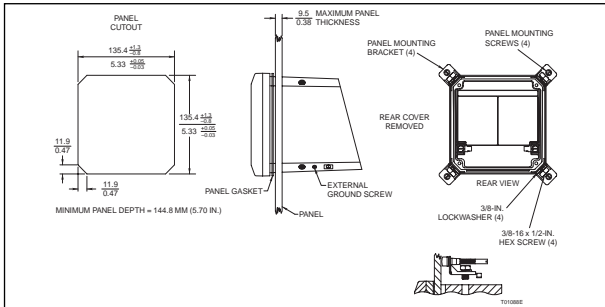

Figure 8 – Panel Mounting Detail

ELECTRICAL CONNECTIONS



Warning.

Use this equipment only in those classes of hazardous locations listed on the nameplate. Uses in other hazardous locations can lead to unsafe conditions that can injure personnel and damage equipment.

The bus powers the transmitter; thus, power and fieldbus signals share the same pair of wires. Separate conduit for power and sensor wiring is encouraged. Prior to entering the instrument housing, terminate rigid conduit and install a short length of flexible conduit to reduce stress to the housing. Signal wiring must not come in close proximity to high-power equipment or to cabling from such equipment. Wiring must be in accordance to the applicable local codes and fieldbus requirements (see Supplementary Documentation). Bus cabling must conform to IEC 61158-2.

The terminal blocks located in the rear of the transmitter accept wire sizes from 12 to 24 AWG. Pin-style terminals should be used for all connections. The terminal block label identifies all electrical connections and should be followed when wiring the transmitter. Observance to polarity is not required; however, polarity indications have been provided for consistence. Voltage requirements are listed in the Specifications and must be observed. Ensure the power supply that provides bus power is compliant with IEC 61158-2.

Normal grounding practice is to terminate all grounds in the control room side, in which case the field side of the screen should be adequately protected to avoid contact with metallic objects. For bus-powered systems, the grounding of the shield should be close to the power supply unit. For IS systems, the grounding should be at the safety barrier earth connection. The transmitter case should be grounded. Ground connections are provided internally (in the terminal compartment) and externally.

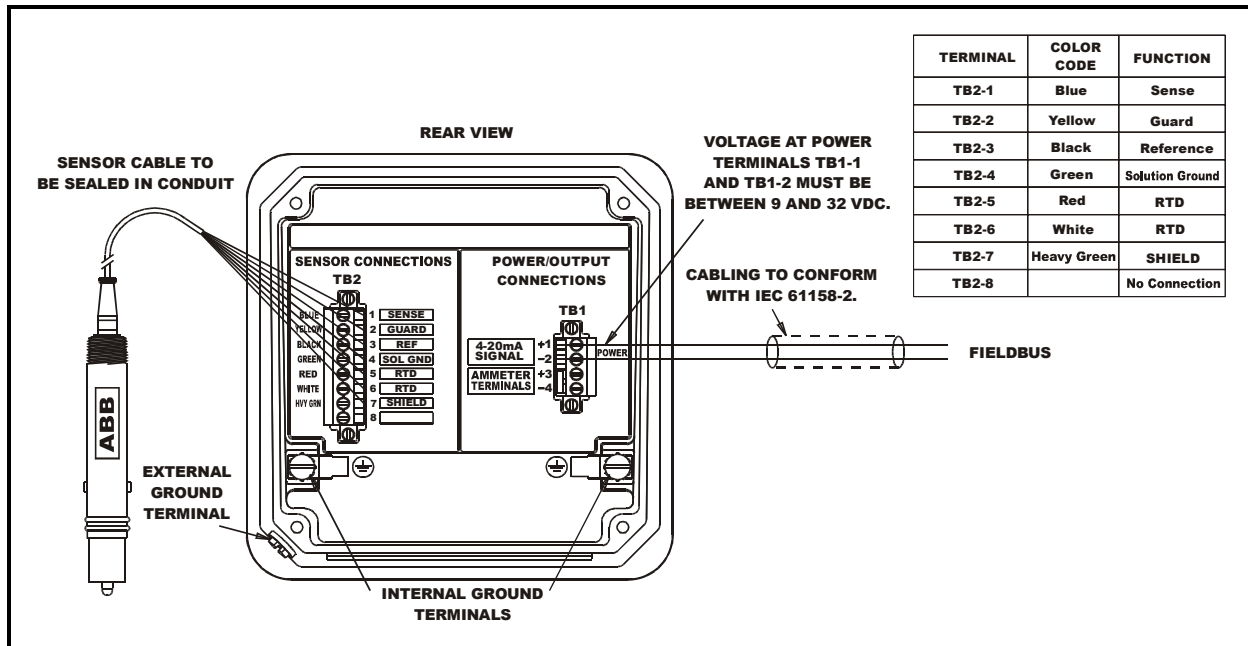

Figure 5 – Sensor and Power Wiring

... ELECTRICAL CONNECTIONS

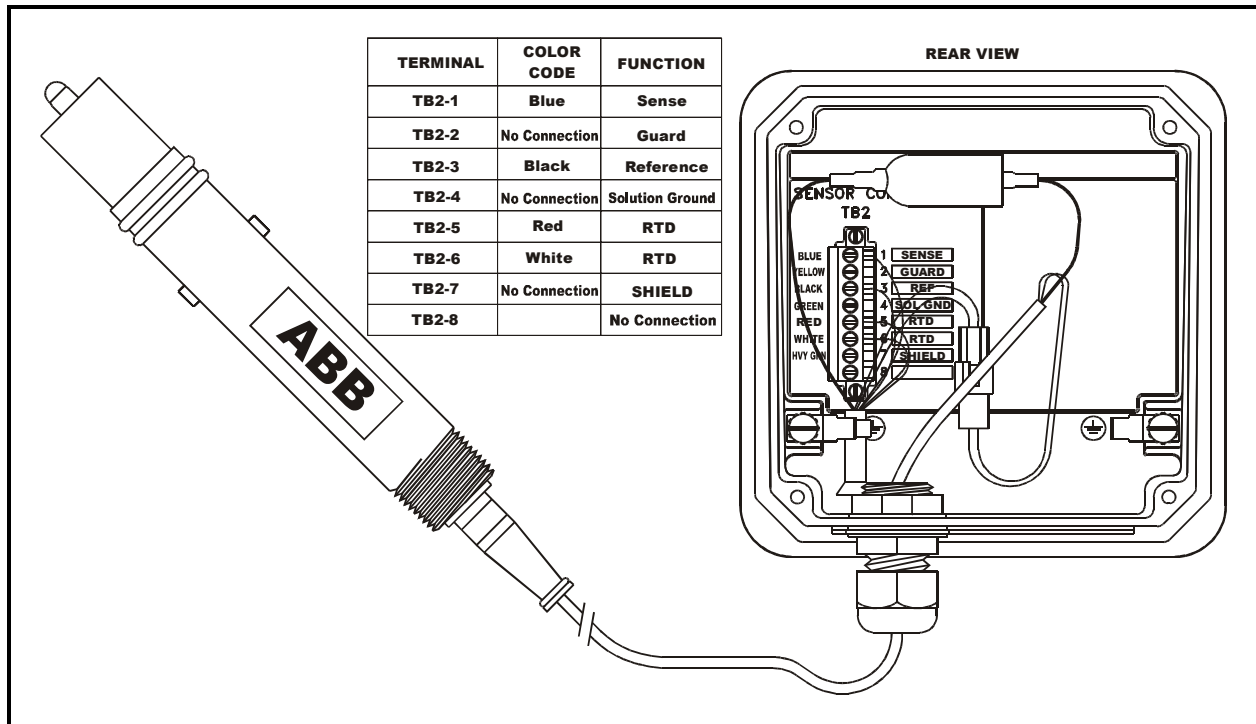

Figure 6 – BNC Adapter Sensor Connections

To ensure fault-free communication, the bus must be properly terminated at both ends. Only approved bus terminators must be used for intrinsically safe circuits. The specific noise immunity and emitted interference are only guaranteed when bus screening is fully effective (e.g., ensuring that screening is maintained through any existing junction boxes.) Appropriate equi-potential bonding must be provided to avoid differences in potential among the individual plant components.

Two hundred fifty-five addresses per segment are allowed.

- Addresses from 0 to 15 are reserved for group addressing and Data Link (DL) use.
- Addresses from 16 to 247 are reserved for devices.
- Addresses from 248 to 251 are non-visitor addresses used as defaults for devices using address assignments.
- Addresses from 252 to 255 are visitor addresses used for temporary (handheld) devices.

The number of transmitters or devices that can be connected to a bus is also dependent on the transmitters'/devices' power consumption, the type of cable, number of spurs, total cable length of the bus, and intrinsically safe requirements.

The table below lists some considerations that have been identified by the FOUNDATION Fieldbus Organization.

Parameters	Specification	
Data Rate	31.25 Kbits/s	
Type	Voltage	
Topology	Bus/tree	
Bus Power	DC	
Intrinsically Safe	No	Yes
Max Nr of devices (1)	32	6
Max cable length (2)	1900 m	
Max spurs length (3)	120 m	

Notes:

- 1) The number of devices is dependent on several physical parameters (e.g., power consumption, bus cable, device IS parameters, etc.).
- 2) Length includes bus and all spurs lengths.
- 3) The maximum Spur length with one device is 120 m; 30 m less for each addition device.

For further information on FOUNDATION Fieldbus installations, see Supplementary Documentation list at the beginning of this manual.

LOCAL HMI OPERATING PROCEDURES

The TB82PH pH/ORP/pION FF Transmitter has seven main operating modes: Measure, Calibrate, Output/Hold, Configure, Security, Secondary Display and Utility. Within each mode, several programming states containing functions specific to the related mode are available.

Using a patented HMI, programming or accessing information from the transmitter's front panel is quick and easy. The LCD contains nine regions that provide the user with information on the process variable, engineering units, mode of operation, fault indication, secondary variable, and function key assignment (see Figure 2). The primary process variable is displayed in the three and one-half digit region. The Engineering Unit region supports this region. These display regions are active in all modes of operation; however, some programming states also use these regions for data entry.

The secondary variable is displayed in the six-character region. This display region is used for displaying secondary and fault information in the Measure Mode and textual prompting in all other modes.

Due to the limited number of characters supported by the secondary display, many of the prompts take the form of a text abbreviation (see Glossary of Programming Text Prompts for a list of abbreviations.) The secondary display region is active in all modes of operation.

A five-button, tactile keypad is located on the front panel of the instrument. Four of the buttons are embossed to easily show their location. A fifth, hidden button located at the top, center of the keypad provides access to functions that are infrequently used. The embossed keys do not have a pre-assigned function. Icons are energized over the key to indicate their function. If a key does not have an icon energized above its location, this key does not have a function and will not initiate an action when pressed. The first table below lists all key functions.

The Measure Mode is the normal operating mode of the transmitter and is the default mode upon power-up. The Measure Mode is the starting point for entry into other modes of operation. Each mode contains a unique set of transmitter functions or states. These modes and their related functions are listed in the second table below.

Icon	Key Function
Exit to MEASURE	Escapes back to the Measure Mode from all other modes or programming states of operation. This function is not available in the Measure Mode.
FAULT Info	Accesses information on diagnostic problem or error conditions. Displays this information as a short text string and code. This function is only available in the Measure Mode.
SELECT	Selects the mode or programming state of operation shown in the secondary display region.
ENTER	Stores configured items and data into memory.
NEXT	Increments through a series of programming states.
YES	Affirms the action that is about to take place.
NO	Denies the action that is about to take place.
MENU	Increments through the modes of operation.
▲	Increases numeric values or moves through a series of parameters.
▶	Moves the flashing data entry value one space to the right.
▼	Decreases numeric values or moves through a series of parameters.

Mode	Function
Measure	Used to display the process and secondary variables – the normal operating mode for the transmitter.
Calibrate	Used to calibrate input devices (i.e., the process and temperature sensors).
Out/Hold	Used for viewing critical parameters found in the Transducer and Analog Input Function Blocks.
Configure	Used to configure transmitter functions such as temperature compensation, temperature sensor type, and measurement electrode type.
Security	Used to enter password protection for the Calibrate and Configure Modes.
Display	Used to select the variable that will be shown in the secondary display region when the transmitter is in the Measure Mode.

The Two-Point Calibrate State conducts offset and slope adjustments on the sensor input to determine its response characteristics. This calibration is typically conducted before the sensor is installed into its final location and periodically during the life of the sensor as the response of the sensor begins to decrease. This calibration procedure uses buffers or standards depending on the type of sensor (e.g., pH, ORP).

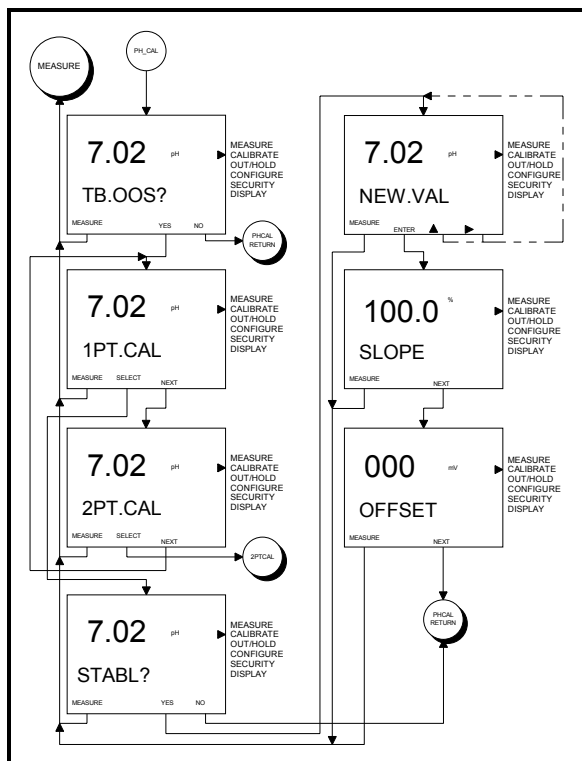

Figure 8 – Screen Flow Diagram for Process Variable Calibrate and One-Point Calibrate States of Operation

Invalid calibration values will generate the text string BAD.CAL (i.e., Bad Calibration), and the calibration value will not be accepted. If the values are valid, the Efficiency (shown as a percentage of theoretical) will be shown. Pressing the NEXT key displays the Offset value. At this point, the user can return to the Process Sensor Calibrate State by pressing the NEXT key or to the Measure Mode by pressing the Exit to MEASURE key.

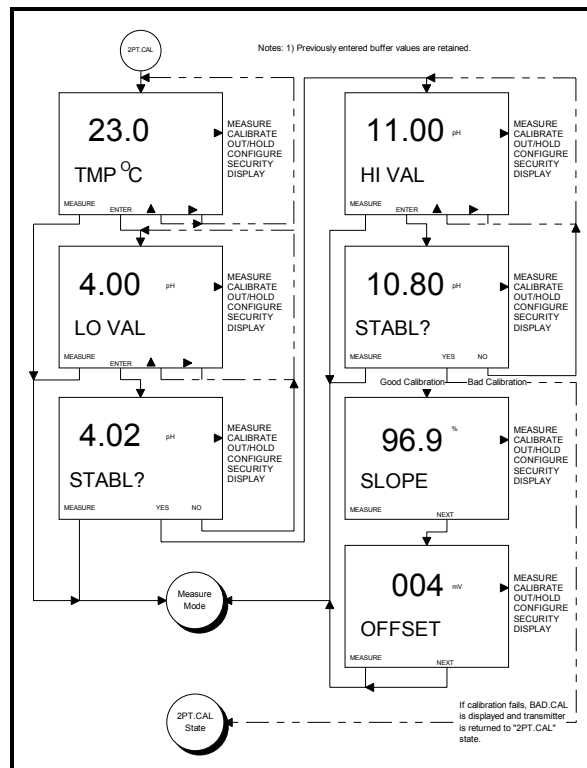

Figure 9 – Screen Flow Diagram for Two-Point Process Calibration

Temperature Calibrate State

The Temperature Calibrate State is a smart calibration routine that allows for both single- and dual-point calibration. By calibrating the temperature at two points that are at least 20°C apart, the transmitter adjusts the offset and slope. Since this routine only uses the most recent calibration data, calibrations can be conducted throughout the sensor's life to ensure accurate measurement of the temperature. If an incorrect calibration has been entered, the Reset Calibrate State can restore the calibration to factory settings.

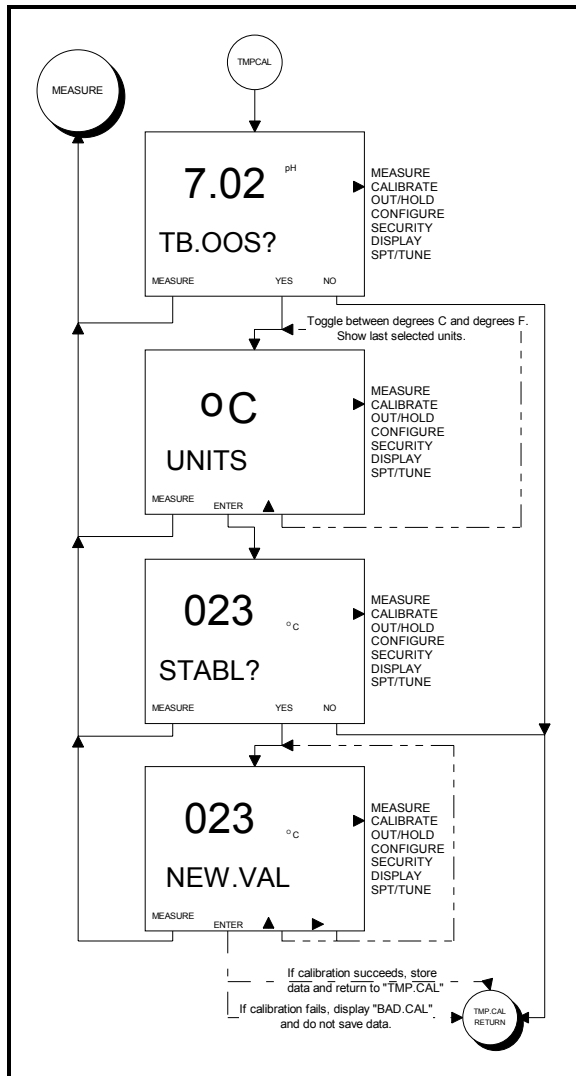

Figure 10 – Screen Flow Diagram for Temperature Calibrate State of Operation

Edit Calibrate State

The Edit Calibrate State allows a user to manually adjust the sensor and temperature slope and offset values. Though this function may not be suitable for many applications, the Edit Calibrate State facilitates quick and easy access to these calibration values for troubleshooting purposes and to make separate adjustments to process variable and temperature data.

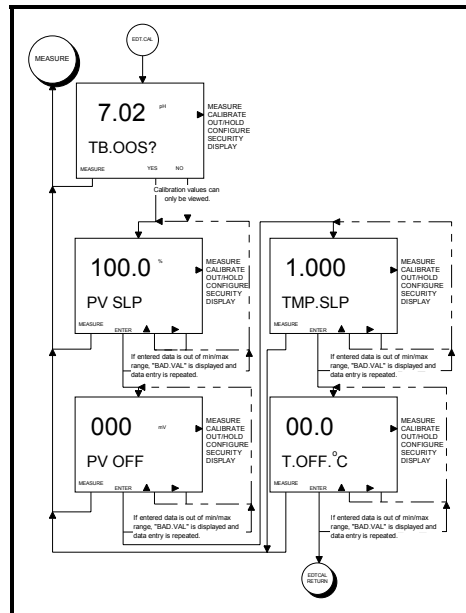

Figure 11 – Screen Flow Diagram for Edit Calibrate State of Operation

Reset Calibrate State

The Reset Calibrate State sets the sensor and temperature calibration data to factory values. This state purges calibration history and should be initiated before calibrating a new sensor.

When interrogating the calibration values after a reset has been performed, the slope and offset values for both the process and temperature sensors will be set to 100%/1.000 and 000 millivolts/000C, respectively.

* Note

The Reset Calibrate State will reset all calibration values; therefore, the process sensor and temperature sensor will require calibration after performing the Reset Calibrate procedure.

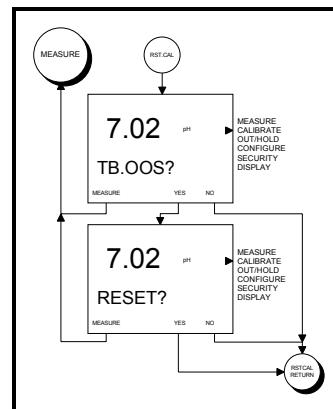

Figure 12 – Screen Flow Diagram for Reset Calibrate State of Operation

OUTPUT/HOLD MODE

The Output/Hold Mode provides the ability to view a limited number of Transducer Block (TB) and Analog Input (AI) Function Block parameters. Fieldbus Foundation requirements prevent local adjustments using the HMI of the transmitter for function block parameters other than those located in the TB. Parameter viewing is limited to the TB Process Variable Range, AI Block mode status, AI Output Value, AI Field Value, and AI Process Value.

The TB Range State contains the process value low and high range limits. These represent the range limits used to define the Field Value.

The AI Block information shows the current mode (i.e., Out of Service – OOS, Auto, or Manual) of the specified function block (i.e., AI1 or AI2). For in service blocks, information for the Output, Process and Field Values is shown. If the block is out of service, the Process and Field Values will contain the last values written to them when the block was in service. If the block was never in service, these parameters will be zero.

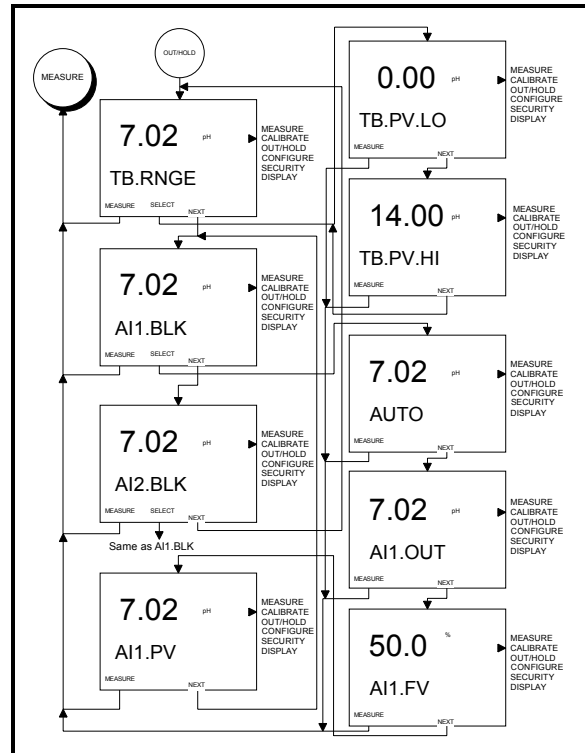

Figure 13 – Screen Flow Diagram for Output/Hold Mode and States of Operation

CONFIGURE MODE

The Configure Mode establishes the operating parameters of the transmitter. These parameters include analyzer type, temperature sensor type, temperature compensation type, linearity type and diagnostic functionality.

Upon selecting the Configure Mode at the local HMI, a query to Modify or View the configuration will be presented. The Modify Configure State enables analyzer options to be set and saved into memory. To access the Modify State, the Transducer Block must be put Out Of Service either from the local HMI upon entry into the Modify State or from a remote configuration tool.

Since the Modify State can be secured, the configuration of the transmitter can be viewed using the View Configure State without violating secured settings. To provide quick and easy access to edit transmitter parameters from the View Configure State, a Hot Key function provides immediate access to the viewed parameter using the ENTER key. If the Modify Configure State is secured, the security code will be requested before entering into the Modify Configure State.

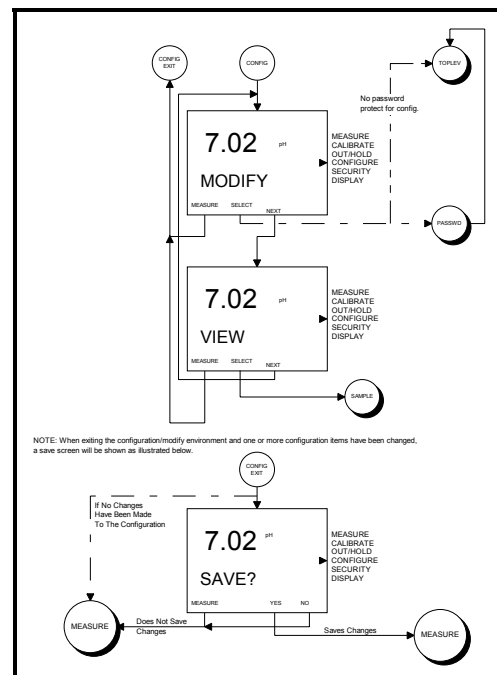

Figure 14 – Screen Flow Diagram for Modify/View and Save States of Operation

Any changes to the transmitter configuration must be saved. Pressing the Exit to MEASURE key prompts the user to "SAVE?" their changes. Pressing the YES key saves the new configuration and returns the transmitter to the Measure Mode. The NO key discards the changes and returns the transmitter to the Measure Mode. Upon exiting from the Modify state, the TB mode is returned from Out-Of-Service to its previously set state.

The Modify Configure State contains all the available settings that establish the functionality of the transmitter. Upon receipt of the transmitter, the default configuration (unless otherwise specified by the customer when ordering the transmitter) will be active once the transmitter has been powered. See the Configuration Data Sheet at the end of this manual for default configuration settings. Before installing the transmitter, the configuration should be modified to reflect the final installed application. The Table below describes each of the Modify Configure States and their function.

State	Function
ANALZR	Used to define the type of analyzer. Choices include pH, ORP, and pION.
TMP.SNS	Used to define the type of temperature sensor. Choices include None, Pt100, and 3k Balco.
TC.TYPE	Used to define the type of temperature compensation. Choices include Manual Nernstian, Automatic Nernstian, and Automatic Nernstian with Solution Coefficient.
LIN.TYP	Used to characterize the Function Generator response curve.
DIAGS	Used to set the sensor diagnostics ON or OFF.

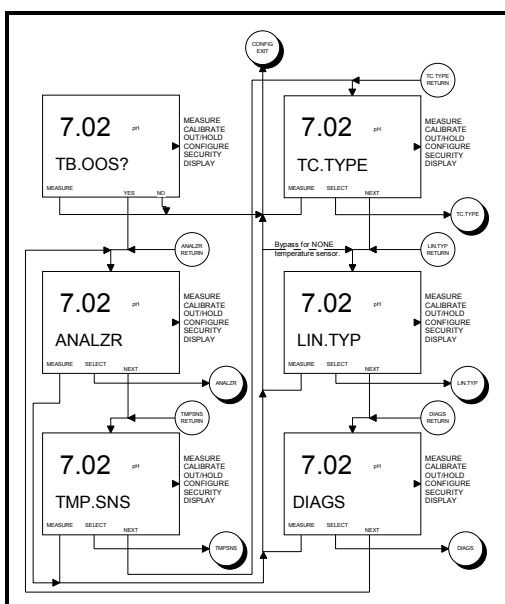

Figure 15 – Screen Flow Diagram for Modify Configure States of Operation

Analyzer State

The Analyzer State sets the type of measurement (i.e., Process Value). The setting of this parameter must match with the type of sensor being used. Three choices are available and include pH, ORP, and pION.

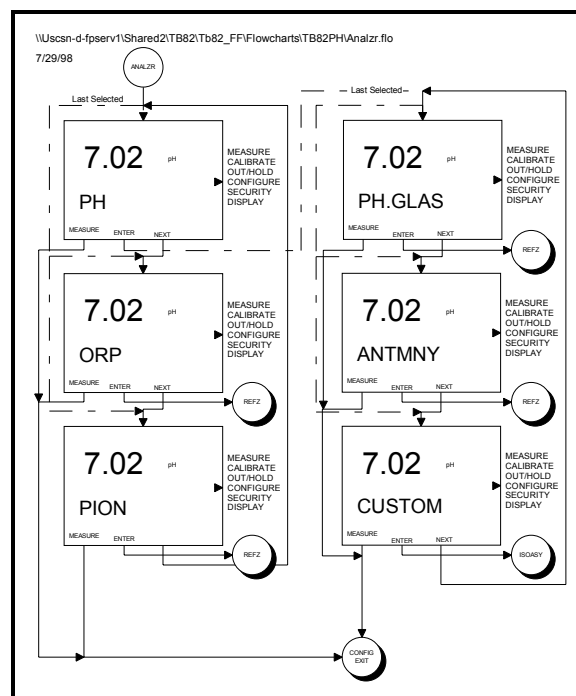

Figure 16 – Screen Flow Diagram for Analyzer and pH Analyzer States of Operation

For transmitters configured as a pH Analyzer, three types of measuring electrode settings are available: Glass (PH.GLAS), Antimony (ANTMNY), and CUSTOM. Glass and Antimony measuring electrode types use the following Isopotential Point and Asymmetric Potential settings:

pH Measuring Electrode Type	Isopotential Point (pH)	Asymmetric Potential (mV)
Glass	7	0
Antimony	-0.8	140
Custom	User Defined	User Defined

The CUSTOM Sensor State provides the ability to set the ISO.PT and ASY.POT. This setting would be used on sensors that use non-conventional measuring and reference electrochemical electrode technology.

The ORP and PION Analyzer States do not require measuring electrode information. These states strictly convert the raw millivolt signal from the sensor to a post-calibrated value that is displayed on the local HMI and transmitted onto the bus.

The final step in setting the Analyzer State is defining the reference electrode impedance trigger point (REF Z). When the transmitter detects a reference electrode impedance that exceeds the Ref Z value, a diagnostic alert is displayed at the local HMI and sent onto the bus. This alert indicates that the sensor's reference electrode requires servicing. Typically, a new ABB sensor will have a reference impedance of 1 to 2 kohms. Performance of the reference electrode is typically unaffected up to approximately 100 kohms, the default REF Z value. Adjustment to other resistance values up to 1000 kohms is allowed; however, the user must determine the acceptable performance of the sensor and adjust the resistance values accordingly.

Temperature Sensor State

The Temperature Sensor State configures the transmitter for use with a Pt100, 3 kohm Balco, or no RTD (NONE).

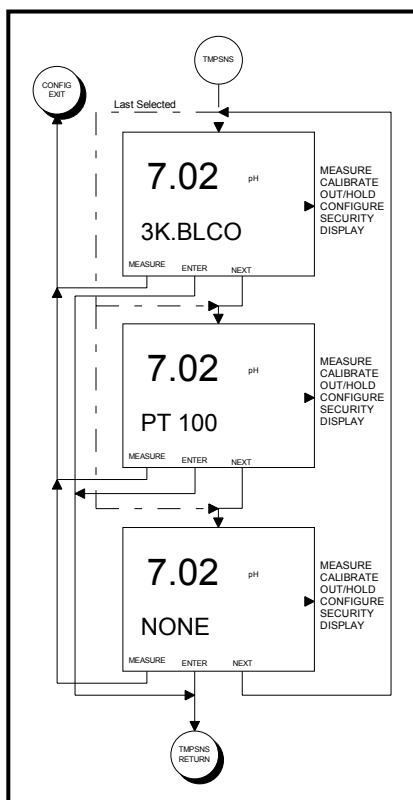

Figure 17 – Screen Flow Diagram for Temperature Sensor State of Operation

Temperature Compensation State

Temperature affects the process variable in two ways. The first effect, Nernstian, causes the sensor output to increase with increasing temperature. In the case of a pH sensor, the increase is roughly 0.03 pH per pH Unit from 7 pH per 10°C. The second temperature effect is on the actual chemistry of the solution. Since ion disassociation can be a function of temperature, ion properties such as pH, ORP, and plon are affected by changes in the process temperature. These effects can be empirically determined and included in the temperature compensation algorithm using the Automatic Nernstian with Solution Coefficient Temperature Compensation option.

The Temperature Compensation State sets the desired compensating method. The three states of temperature compensation include Manual Nernstian (MANUAL), Automatic Nernstian (AUTO), and Automatic Nernstian with Solution Coefficient (AUT.SOL). The table below provides a brief description of each type of temperature compensation.

State	Function
MANUAL	Used when a fixed temperature value can be applied instead of a measured value. The initial value is set at 25°C. Use the Temperature Calibrate State to change the fixed temperature value. Nernstian compensation is applied using the fixed temperature value.
AUTO	Used when a temperature sensor is providing a measured temperature value. Nernstian compensation is applied using the measured value.
AUT.SOL	Used when a temperature sensor is providing a measured temperature value. Nernstian compensation with a solution coefficient is applied using the measured value.

Figure 22 shows the selection of temperature compensation type.

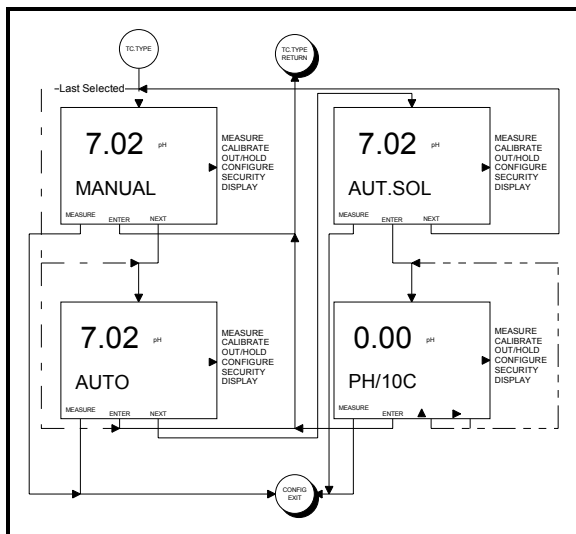

Figure 18 – Screen Flow Diagram for Temperature Compensation State of Operation.

Linearity Type State

The Linearity Type State controls the output relationship of the internal Function Generator algorithm used to generate one of the Secondary Values (SV4). When the Linearity Type State is set to LINEAR, the SV4 channel will provide a linear output in percentage units that has the output range determined by the Primary_Value_Range. To enable a non-linear output at SV4, the Linearity Type must be set to NON.LIN and five pairs of characterization data must be entered.

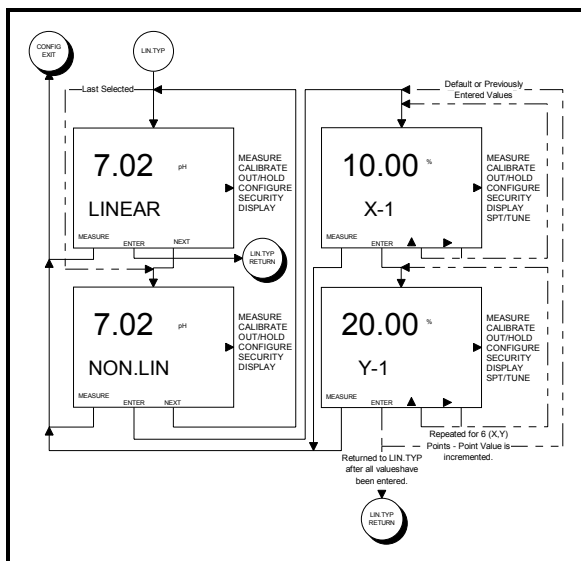

Figure 19 – Screen Flow Diagram for Linearity Type State of Operation

The NON.LIN parameter automatically uses the end point values defined by the Primary_Value_Range; thus, end point values do not need to be entered as characterization data. The five pairs of characterization data define the break point for a linear representation of a curve. To define the break points, a plot of the process variable against the desired output (or variable that represents the output value) must be segmented into six linear regions. The points where the linear regions intersect should fall on the non-linear function and represent the break points that are entered as the characterization data.

Diagnostic State

The Diagnostic State contains a toggle to enable (ON) or disable (OFF) built-in sensor diagnostic detection. When a sensor does not have a solution ground such as a TB5 sensor, the diagnostic signal cannot be injected into the process liquid. For these situations and applications that use very pure water, sensor diagnostics should be disabled.

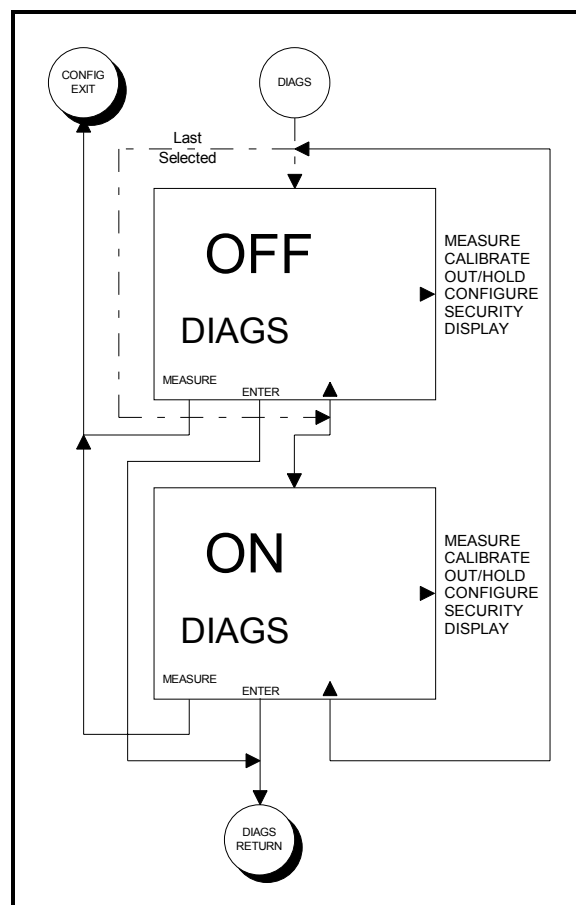

Figure 20 – Screen Flow Diagram for Diagnostic State of Operation

SECURITY MODE

The Security Mode establishes password protection against unauthorized changes to transmitter functions. Password protection can be assigned to the Calibrate and Configure Modes. Additional Security functions are available in the Resource Block and will be discussed in Resource Block Section.

The Security Mode provides password protection of critical operating environments. When in the Security Mode, toggling the primary display between security OFF and ON sets password protection for the mode displayed in the secondary display area. When one or more modes have been secured, the security password must be correctly entered at the Password State before entry into the Security Mode is allowed. One password assignment applies to all secured modes.

To prevent misuse of the security function by a malicious user, the Security Mode can be password protected without securing one or both other modes of operation.

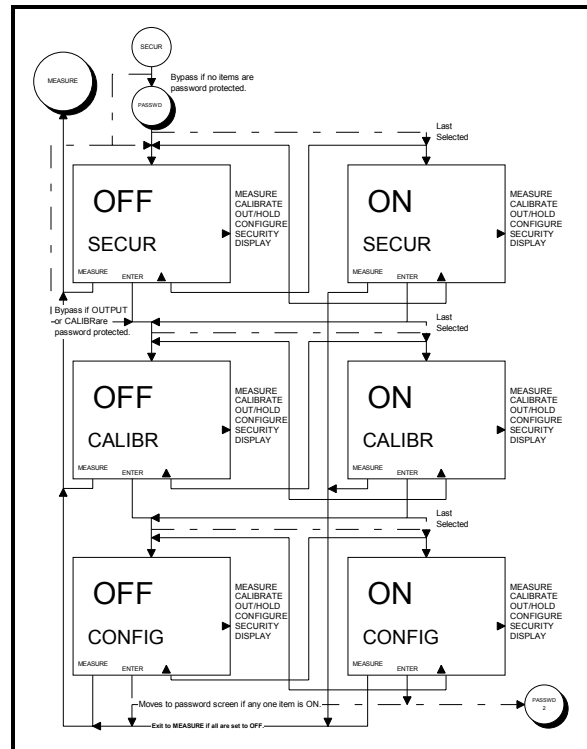

Figure 21 – Screen Flow Diagram for Security Mode of Operation

SECONDARY DISPLAY MODE

The secondary display region can be configured to display one of a multitude of process, sensor, or transmitter parameters in the Measure Mode. The Secondary Display Mode provides the ability to view these parameters or to set one parameter active in the Measure Mode. These parameters include temperature in °C, temperature in °F, sensor output, reference impedance, function generator output, and software revision. The NEXT key cycles through the parameters, while the ENTER key sets the displayed parameter as the secondary display value when in the Measure Mode.

For temperature parameters, a superscript 'M' at the end of the temperature value indicates that the transmitter's Temperature Compensation State is set to Manual.

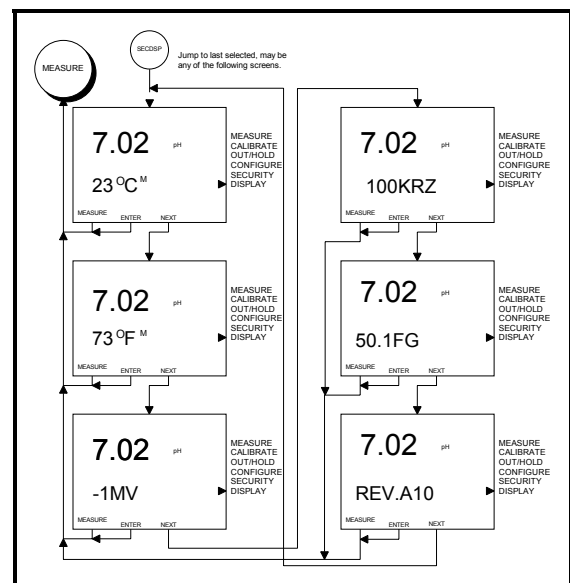

Figure 22 – Screen Flow Diagram for Secondary Display Mode of Operation

UTILITY MODE

The Utility Mode provides access to powerful functions not used during normal operating conditions. These functions have been separated into two categories: Factory and User. Factory functions are strictly reserved for factory personnel. User functions include Reset Configuration to default settings, Reset Security password, Reset All parameters to default settings, Software Reboot, FF Identification and Damping functions.

The User States can be accessed using the hidden fifth key located top, center of the keypad above the display window (see Figure 2). Once the hidden key has been pressed, the secondary display will have the prompt 'USER' shown. The SELECT key provides access to the User States.

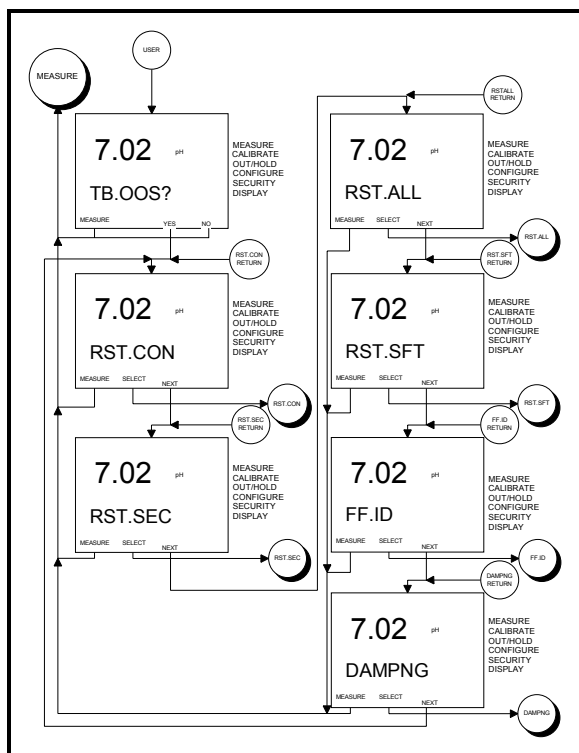

Figure 23 – Screen Flow Diagram for User States of Operation



Caution

Since the Utility Mode contains functions that can have a dramatic effect on the proper function of the transmitter, the Transducer Block should be put Out Of Service until all transmitter parameters have been properly set. For convenience, the Transducer Block can be put Out Of Service at the local HMI; however, once the transmitter is returned to the Measure Mode of Operation using the Exit to MEASURE key, the transmitter will automatically return the Transducer Block into its previous state.

Reset Configuration State

The Reset Configuration State returns the configuration to factory default settings. If the Configure Mode has been password secured, the same password will be required to perform a reset to the transmitter's configuration. See the Configuration Worksheet at the end of this manual for software default settings.

Reset Security State

The Reset Security State returns the security to factory default settings. The factory default is security OFF for all applicable modes (i.e., Security, Calibrate, and Configure). To reset the security, the password **732** must be entered when requested by the transmitter.

Reset All State

The Reset All State returns all transmitter parameters back to factory defaults. This includes calibration, configuration, security, and secondary display values. To reset all transmitter parameters, the password **255** must be entered when requested by the transmitter.



Note:

All user specific information will be lost once a Reset All or Reset Configuration has been initiated. Before initiating these reset functions, record configuration data to make reconfiguration quicker.

Reset Software State

The Soft Boot State initiates a software reset. A software reset repeats the boot-up and self-test process. All programmable instrument parameters are unaffected by this function.

Transmitter Identification (FF.ID) State

There are several ways to identify a transmitter in the network, and more precisely, three different addressing levels are used to characterize a FOUNDATION Fieldbus device.

The most important is the Device Identifier (i.e., DEV_ID). This identifier is a string of 32 characters and provides a unique FOUNDATION Fieldbus device address by incorporating a manufacturer code, device type code, device type identification, and sensor serial number.

Since this identifier must have a unique value, the FF.ID state is password protected. To access to this screen, a user must contact the factory for further instructions.

Damping State

The Damping State applies a lag function on the process input. The Damping State values affect Process and Secondary Value 4 (Function Generator) transmitted values. Application of the FV_VALUE in the AI blocks will apply an additional damping on the mapped variable. To adjust the Damping State, the password **367** must be entered when requested by the transmitter.

TRANSMITTER'S FIELDBUS FUNCTIONALITY

The Data Link Layer of Fieldbus FOUNDATION Protocol defines three types of device:

- Basic device
- Link Master
- Bridge

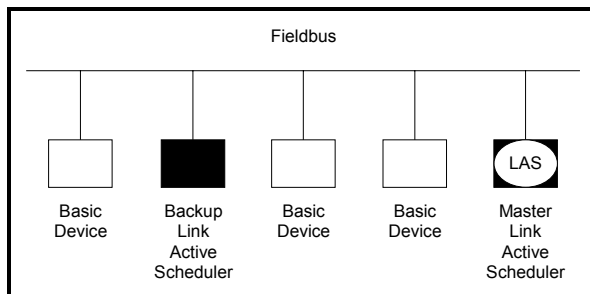

The **Link Master** device is typically the Link Active Scheduler (LAS); thus, it is responsible for organizing the activity/communication on the fieldbus. **Basic Devices** do not have the capability to become the LAS. Bridges are used to interconnect individual fieldbuses to create larger networks.

A Fieldbus may have multiple Link Masters. If the primary LAS device fails, one of the other Link Masters will assume LAS responsibilities. In this manner, the operation of the fieldbus link will be maintained. **The TB82PH Foundation Fieldbus Transmitter does not have the capability of being a backup LAS device.** Below is a complete list of the transmitter fieldbus functionality:

- **Standard Resource Block:** This block contains the description of the transmitter characteristics.
- **Standard Analog Input Function Block:** Two Analog Input Function Blocks are available for control loop operations.
- **Enhanced Transducer Block with calibration capability:** This block contains configuration parameters, calibration functions, and diagnostic

data.

The transmitter allows different types of communication services as described by the Fieldbus Message Specification (FMS). These FMS services permit a User Application to send serial messages to each device across the fieldbus network using a standard message format. FMS describes the communication services, the format of the message, and the protocol behaviors required to build messages for the User Application. A pictorial illustration of this methodology is shown below.

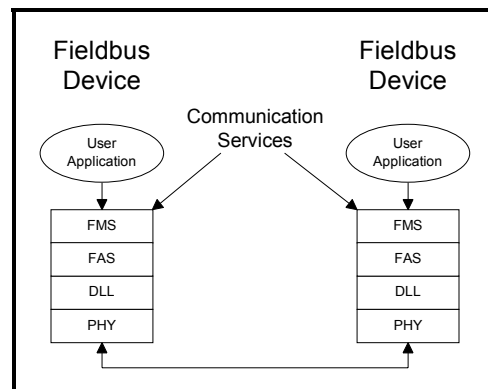

The **FMS Services** supported by the transmitter are listed below:

- **Initiate** - used to establish the initial communication.
- **Abort** - used to release the communication.
- **Status** - used to read a device status.
- **Identify** - used to read vendor, type and version information.
- **Read variable** - used to read a variable.
- **Write variable** - used to write a variable.
- **Get Object Dictionary** - used to read an Object Dictionary.

The transmitter provides support for all **Virtual Communication Relations (VCR)**. These relationships represent the rules for communication between objects connected on the fieldbus. Below is a brief description of these communication relationships.

Client/Server VCR Type

This type of communication is used for configuration and maintenance purpose and includes functions such as setting parameter access, changing parameter values, alarm acknowledgement, uploading and downloading parameter values. In other words, this type of communication is used for queued, unscheduled, user initiated, one to one communication between devices on the fieldbus. The LAS is responsible for distributing and assigning a Pass Token (PT) to the devices on the fieldbus. The device that has the token can send a request to another device. The requesting device is called the **Client** and the device that receives the request is called the **Server**.

Report/Distribution VCR Type

This type of communication is typically used by fieldbus devices to send alarm notifications and trend reports to a Master Device. This type of communication is a queued, unscheduled, user initiated communication between one and many other devices.

Publisher/Subscriber VCR Type

This type of communication is used for Process Control purposes. When a device has been scheduled to send data, this data is **Published** or broadcasted onto the fieldbus. Devices that wish to receive this Published data are called **Subscribers**. This type of communication is a scheduled and cyclic exchange of data and is used to publish function block inputs and outputs such as process variable and primary output information onto the fieldbus.

Refer to the following figure for a summary of the VCR Types.

FIELDBUS ACCESS SUBLAYER SERVICES		
Client/Server VCR Type	Report/Distribution VCR Type	Publisher/Subscriber VCR Type
Used for Operator Messages	Used for Event Notification and Trend Reports	Used for Publishing Data
<ul style="list-style-type: none"> • Mode Changes • Tuning Changes • Upload/Download • Alarm Management • Access Display Views • Remote Diagnostics 	<ul style="list-style-type: none"> • Send Process alarms to operator consoles • Send trend report for data histories 	<ul style="list-style-type: none"> • Send transmitter PV and SV data to control blocks and operator consoles
DATA LINK LAYER SERVICES		

DEVICE BLOCKS

All variables and parameters of the transmitter are structured in blocks with respect to their assignment of components or functions. This structure is termed the Function Block Application Process (FBAP) and has been designed to support five primary operational characteristics:

1. Configuration and definition of function blocks
2. Configuration of function block links
3. Alert processing
4. Access to information for operator interface, remote operation, diagnostics, and configuration
5. Coordinating function block execution and communication

The basic elements of the FBAP are as follows:

- Block Objects and Parameters
 - Resource Block
 - Transducer Block
 - Function Block (e.g., Analog Input, Analog Output, PID, etc.)
- Link Objects: Allows the transfer of data between blocks as defined by the Virtual Communication Relationship (VCR).
- Alert Objects: Used to communicate alerts and/or events to other devices.
- Trend Objects: Used to maintain a history of values of an individual parameter.
- View Objects: Used to group a subset of operation and configuration data.
- Domain and Program Invocation Objects: Used to support download and upload services.

Blocks are logical groups of device functionality that define a particular application using a common model. In general, blocks process input parameters and events through one or more process algorithms and execution controls in order to produce the expected output parameters and events. Block parameters control the function and execution of the block and are visible over the fieldbus network. Data communicated over the fieldbus is expressed as an "object description". Object descriptions are collected together in a structure called an Object Dictionary (OD) and are identified within the OD by their index. During system operation, block parameters are accessed using an OD index.

Since most plants have many different process control requirements, the type of functions can greatly vary. The Fieldbus Foundation specifications identify a range of function blocks, each addressing a different need. These standard function blocks provide a common structure for defining block inputs, outputs, control parameters, events, alarms, and modes. This common structure can then be easily

used in a wide range of process control and monitoring devices.

The Resource Block contains the hardware specific characteristics associated with a device. This block does not have input and output parameters; instead, it contains an algorithm that monitors and controls the general operation of the physical device hardware. For example, the mode of the Resource Block impacts all of the other blocks. Other Resource Block parameters include but are not limited to the manufacturer's name, device name, and serial number. Only one resource block is included per device.

The Transducer Blocks connect input and output functions to other function blocks residing in the same device. It interfaces with sensor input hardware and provides a measured value and status to connected function blocks. Transducer Block parameters include but are not limited to sensor type, temperature sensor type, calibration data and routines, calibration date and diagnostic conditions. Usually only one Transducer Block is present per device.

The Function Blocks are fundamental for providing the control system behavior. Function Blocks contain input and output parameters and algorithms and can be linked to other function blocks within the same device or to other devices in the fieldbus network. In a single User Application, several function blocks can be available and precisely scheduled in terms of execution.

The Fieldbus Foundation specifications have defined a set of standard function blocks. These are as follows:

- Analog Input (AI)
- Analog Output (AO)
- Discrete Input (DI)
- Discrete Output (DO)
- Proportional/Derivative (PD)
- Proportional/Integral/Derivative (PID)
- Bias (B)
- Control Selector (CS)
- Manual Loader (ML)
- Ratio (RA)

The TB82PH FF Transmitter has one Resource Block, two Analog Input Function Blocks (AI), and one enhanced, custom Transducer Block with calibration and function generator capability. The following figure shows block elements for the TB82PH FF Transmitter.

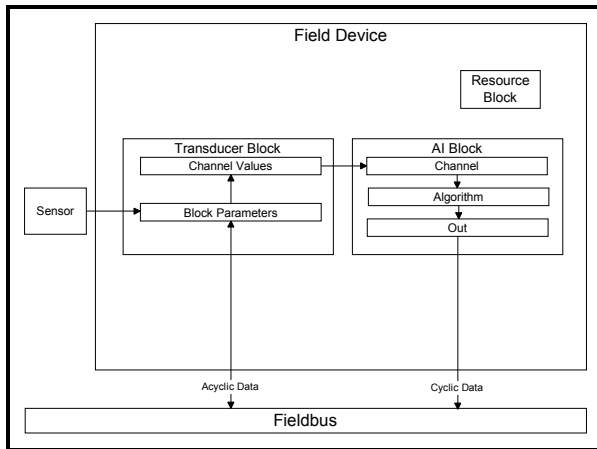

Figure 24 – FBAP Interaction Diagram

Function blocks contain Fieldbus Foundation-defined parameters that have been defined by the specifications governing this communications technology. In addition to these parameters, manufacturer-specific parameters are commonly found in most FF devices. The TB82PH FF Transmitter contains several manufacturer-specific parameters in the Transducer Block; however, the Resource and Analog Input Blocks are standard FF blocks.

As also required by the Fieldbus Foundation specifications, the Device Blocks have to satisfy certain defined operating modes. Each block supports the operating modes as described in the table below.

Operational Mode	Blocks		
	Resource	Transducer	Analog Input
Manual (MAN)	N/A	N/A	YES
Automatic (AUTO)	YES	YES	YES
Out of Service (OOS)	YES	YES	YES

The following tables and diagrams contain information regarding block parameters and the structure of these parameters within the block. To assist in the interpretation of this information, the following list of column definitions is provided.

- Index (IDX) – Defines the number corresponding to the sequence of the parameter relative to the beginning of the corresponding block in the object dictionary

Object Dictionary indices at which the blocks start:

- Resource Block – 259
- Analog Input 1 – 350
- Analog Input 2 – 390
- Transducer Block – 430

- Name – Lists the mnemonic character designation for the parameter.
- Description – Provides a short text description of the block parameter.
- Bytes – Lists the memory size of the block parameter.
- Store (ST) – Defines the type of variable for the block parameter. 'S' represents a Static variable that is typically a device parameter such as the type of temperature sensor or variable linearization function. This variable can only be written during an acyclic process and if the AR is Read/Write. Writing to a static parameter changes the static revision of the counter ST_REV. 'N' represents a Non-volatile variable. Non-volatile parameters are stored internally in the device. This variable is periodically stored to ensure the fixed life of the memory is not shortened. NV_CYCLE_T sets the writing interval. This parameter cannot be changed. 'D' represents a Dynamic variable. The value for this variable is calculated by the block and can be read by another block.
- Access Rights (AR) – Defines the access rights of the block parameter. 'R' represents a parameter that only has Read access. 'R/W' represents a parameter that has Read and Write access.
- Default – Lists the default setting for the listed block parameter during initial start up or when a Cold Start is initiated.
- Valid Range – Lists the valid range of selections for the listed block parameter.
- Note – Identifies additional information for the listed block parameter that is available at the end of the block object tables.

The Resource Block includes data and parameters that defined the overall operation of the device. These parameters describe the hardware specific characteristics of the device. The following table lists the Resource Block parameter information.

RESOURCE BLOCK

IDX	Name	Description	Bytes	ST	AR	Default	Valid Range	Note
0	BLOCK_OBJ	Block Object	62		Mix.			
1	ST_REV	Static Revision	2	S	R	0		
2	TAG_DESC	TAG Description	32	S	R/W			
3	STRATEGY	Strategy	2	S	R/W	0		
4	ALERT_KEY	Alert Key	1	S	R/W	0	1 to 255	
5	MODE_BLK	Target	1	N	R/W	OOS	OOS, Auto	
		Actual	1	D	R	-		
		Permitted	1	S	R/W	OOS, Auto		
		Normal	1	S	R/W	Auto	OOS, Auto	
6	BLOCK_ERR	Block error	2	D	R	-	0 – Off 1 – On	
7	RS_STATE	Resource State	1	D	R	1		
8	TEST_RW	Test	112	D	R/W			
9	DD_RESOURCE	DD Resource	32	S	R			
10	MANUFAC_ID	Manufacturer ID	4	S	R	800 (mfr. ID for ABB)		
11	DEV_TYPE	Device Type	2	S	R	80 (TB82PH FF device type)		
12	DEV_REV	Device Revision	1	S	R	1		
13	DD_REV	DD revision	1	S	R	1		
14	GRANT_DENY	Grant	1	D	R/W	0		
		Deny	1	D	R/W	0		
15	HARD_TYPES	Hardware Type	2	S	R	1	Scalar Input	
16	RESTART	Restart	1	D	R/W			
17	FEATURES	Feature Supported	2	S	R	Reports, Hard Write Lock		
18	FEATURES_SEL	Feature Selected	2	S	R/W	Reports, Hard Write Lock	Reports, Hard Write Lock	
19	CYCLE_TYPE	Cycle Type	2	S	R	Scheduled, Completion of block execution		
20	CYCLE_SEL	Cycle Selected	2	S	R/W	Scheduled, Completion of block execution	Scheduled, Completion of block execution	
21	MIN_CYCLE_T	Min Cycle Time	4	S	R	1600 1/32 msec (50 msec)		
22	MEMORY_SIZE	Memory Size	2	S	R			
23	NV_CYCLE_T	Non-Volatile Cycle Time	4	S	R			
24	FREE_SPACE	Free Space	4	D	R	-	0-100 %	
25	FREE_TIME	Free Time	4	D	R	-	0-100 %	
26	SHED_RCAS		4	S	R/W	640000		
27	SHED_ROUT		4	S	R/W	640000		
28	FAULT_STATE	Fault State	1	N	R		1- Clear 2- Active	
29	SET_FSTATE	Set Fault State	1	D	R/W	1		
30	CLR_FSTATE	Clear Fault State	1	D	R/W	1		
31	MAX_NOTIFY	Max Notifications	1	S	R	8		

RESOURCE BLOCK (cont'd)

IDX	Name	Description	Bytes	ST	AR	Default	Valid Range	Note
32	LIM_NOTIFY	Limit of Notifications	1	S	R/W	Max_Notify	0 to Max_Notify	
33	CONFIRM_TIME	Confirmation Time	4	S	R/W	640000		
34	WRITE_LOCK	Write Locking	1	S	R/W	1	1 – Unlocked 2 – Locked	
35	UPDATE_EVT	Unacknowledged	1	D	R/W	0		
		Update State	1	D	R	0		
		Time Stamp	8	D	R	0		
		Static Revision	2	D	R	0		
		Relative Index	2	D	R	0		
36	BLOCK_ALM	Unacknowledged	1	D	R/W			
		Alarm State	1	D	R			
		Time Stamp	8	D	R			
		Sub-code	2	D	R			
		Value	1	D	R			
37	ALARM_SUM	Current	2	D	R			
		Unacknowledged	2	D	R			
		Unreported	2	D	R			
		Disabled	2	S	R/W	0		
38	ACK_OPTION	Automatic Acknowledge Option	2	S	R/W	0	0 – Disable 1 – Enable	
39	WRITE_PRI	Write Priority	1	S	R/W	0	0 to 15	
40	WRITE_ALM	Unacknowledged	1	D	R/W			
		Alarm State	1	D	R			
		Time Stamp	8	D	R			
		Sub-code	2	D	R			
		Value	1	D	R			
41	ITK_VER	ITK_version	2	S	R	4.0		

The Transducer Block contains block parameters that configure the device's functionality. It insulates the sensor characteristics and signal conditioning from the other device Function Blocks. Specifically, it interprets the sensor signal based on configured values, applies factory and process calibration data, compensates for temperature and process effects, and converts the resulting values in the configured Engineering Units that can be used by the Analog Input Blocks contained within the device.

The following diagram illustrates the Transducer Block design. The following table lists the Transducer Block parameter information.

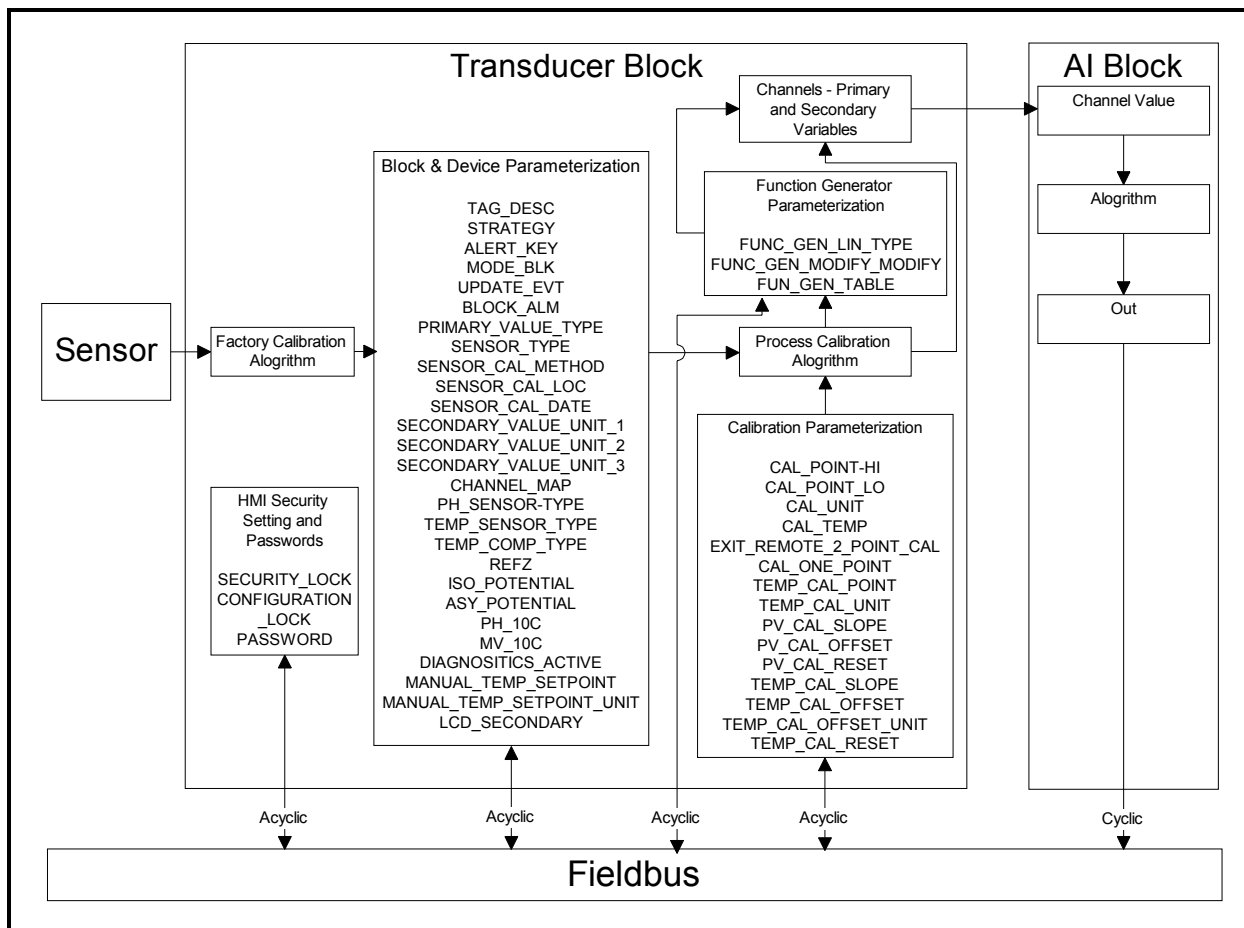

Figure 25 – Transducer Block Design Diagram

pH/ORP/pION TRANSDUCER BLOCK

IDX	Name	Description	Bytes	ST	AR	Default	Valid Range	Note
0	BLOCK_OBJ	Block Object	62					
1	ST_REV	Static Revision	2	S	R	0		
2	TAG_DESC	TAG Description	32	S	R/W	Spaces		
3	STRATEGY	Strategy	2	S	R/W	0		
4	ALERT_KEY	Alert Key	1	S	R/W	0	1 to 255	
5	MODE_BLK	Target	1	N	R/W	OOS	Auto, OOS	
		Actual	1	D	R			
		Permitted	1	S	R/W	Auto, OOS	Auto, OOS	
		Normal	1	S	R/W	Auto	Auto, OOS	
6	BLOCK_ERR	Block error	2	D	R		0 – Off 1 – On	
7	UPDATE_EVT	Unacknowledged	1	D	R/W	0		
		Update State	1	D	R	0		
		Time Stamp	8	D	R	0		
		Static Rev	2	D	R	0		
		Relative Index	2	D	R	0		
8	BLOCK_ALM	Unacknowledged	1	D	R/W	0		
		Alarm State	1	D	R	0		
		Time Stamp	8	D	R	0		
		Sub-code	2	D	R	0		
		Value	1	D	R	0		
9	TRANSDUCER_DIRECTORY	Number of Transducer Directories & Start Indexes	4	N	R			
10	TRANSDUCER_TYPE		2	N	R	65535	65535 (Other)	
11	XD_ERROR	Transducer Error	1	D	R	0		
12	COLLECTION_DIRECTORY		36	N	R			
13	PRIMARY_VALUE_TYPE		2	S	R/W	111	111 – pH 114 – ORP 118 – pION	Note A
14	PRIMARY_VALUE	Value	4	D	R			Note B
		Status	1	D	R			
15	PRIMARY_VALUE_RANGE	High Range	4	N	R	14 pH	Table 3	Note C
		Low Range	4	N	R	0 pH	Table 3	
		Unit Index	2	N	R	1422 (pH)	Table 2	
		Decimal point	1	N	R	2		
16	CAL_POINT_HI	Calibration High	4	S	R/W	14 pH	Table 3	
17	CAL_POINT_LO	Calibration Low	4	S	R/W	7 pH	Table 3	
18	CAL_MIN_SPAN	Minimum Span	4	N	R	1 pH		Note D
19	CAL_UNIT	Calibration Unit	2	S	R/W	1422 (pH)	Table 2	
20	CAL_TEMP	Two-point PV Calibration Temperature	4	S	R/W	25 °C		
21	EXIT_REMOTE_2_POINT_CAL	Exit Remote Two-point PV Calibration	1	S	R/W	0 (No)	0 – No 1 – Yes	
22	CAL_ONE_POINT	One-point Calibration Value	4	S	R/W	0 pH	Table 3	

pH/ORP/pION TRANSDUCER BLOCK (cont'd)

IDX	Name	Description	Bytes	ST	AR	Default	Valid Range	Note
23	SENSOR_TYPE		2	S	R/W	103	103 (mV)	
24	SENSOR_RANGE	High Range	4	N	R	16 pH	Table 3	
		Low Range	4	N	R	-2 pH	Table 3	
		Unit Index	2	N	R	pH	Table 2	
		Decimal point	1	N	R	2		
25	SENSOR_SN	Serial Number	32	N	R	All blanks		
26	SENSOR_CAL_METHOD	Calibration Method	1	S	R/W	104	104 (user trim standard cal)	
27	SENSOR_CAL_LOC	Calibration Location	32	S	R/W	All blanks		
28	SENSOR_CAL_DATE	Calibration Date	7	S	R/W	All blanks		
29	SENSOR_CAL_WHO	Personnel Name	32	S	R/W	All blanks		
30	SECONDARY_VALUE_1	Sensor Temperature Value	4	D	R			
		Status	1	D	R			
31	SECONDARY_VALUE_UNIT_1		2	S	R/W	1001 (°C)	Table 4	
MANUFACTURER SPECIFIC PARAMETERS								
32	SECONDARY_VALUE_2	Sensor Input mV Value	4	D	R			
		Status	1	D	R			
33	SECONDARY_VALUE_UNIT_2		2	S	R	1243 (mV)	1243 (mV)	
34	SECONDARY_VALUE_3	Reference Impedance Value	4	D	R			
		Status	1	D	R			
35	SECONDARY_VALUE_UNIT_3		2	S	R	1284(K-OHM)	1284 (K-OHM)	
36	SECONDARY_VALUE_4	Function Generator Output Value	4	D	R			
		Status	1	D	R			
37	SECONDARY_VALUE_UNIT_4		2	S	R	1342 (%)	1342 (%)	
38	CHANNEL_MAP		5	S	R/W			
39	FUNC_GEN_LIN_TYPE	Linearization Type of Secondary Variable 4	1	S	R/W	1 (Linear)	1 – Linear 255 – Function Generator	Note F
40	PH_SENSOR_TYPE	pH Sensor Type	1	S	R/W	0 (Glass)	0 – Glass 1 – Antimony 2 – Custom	
41	TEMP_SENSOR_TYPE	Temperature Sensor Type	1	S	R/W	0 (3K Balco)	0 – 3K Balco 1 – PT100 2 – None	
42	TEMP_COMP_TYPE	Temperature Compensation Type	1	S	R/W	0 (Manual)	0 – Manual 1- Automatic 2- Auto Solution	
43	REFZ	Reference Impedance	4	S	R/W	100000 Ohm	100000 to 1000000 Ohm	

pH/ORP/pION TRANSDUCER BLOCK (cont'd)

IDX	Name	Description	Bytes	ST	AR	Default	Valid Range	Note
44	ISO_POTENTIAL	Isopotential pH value	4	S	R/W	7.0 pH	-19.9 to +19.9 pH	Note H
45	ASY_POTENTIAL	Asymmetric potential	2	S	R/W	0 mV	-1999 to +1999 mV	Note H
46	PH_10C	pH Solution Coefficient	4	S	R/W	0 pH	-9.99 to +9.99 pH	
47	MV_10C	mV Solution Coefficient	4	S	R/W	0 mV	-19.99 to +19.99 mV	
48	FUNC_GEN_MODIFY_OPTION	Function Generator Modification Option	1	S	R/W	0 (Modify individual entry)	0 – Individual Entry 1- Entire Table	
49	FUNC_GEN_TABLE	Function Generator Table used for Secondary Variable 4	40	S	R/W	x,y 16.7, 16.7 33.3, 33.3 50.0, 50.0 66.7, 66.7 83.3, 83.3	Each point 0.1 to 99.9 Monotonically increasing	
50	DIAGNOSTICS_ACTIVE	Sensor Diagnostics Activation	1	S	R/W	0 (OFF)	0 – OFF 1 – ON	
51	MANUAL_TEMP_SETPOINT	Temperature Value for Manual Temperature Compensation	4	S	R/W	25 °C	0 to 140 °C	Note I
52	MANUAL_TEMP_SETPOINT_UNIT	Manual Temperature Setpoint Units	2	S	R/W	1001 (°C)	Table 4	
53	TEMP_CAL_POINT	Temperature Calibration Value	4	S	R/W	25 °C	0 to 140 °C	
54	TEMP_CAL_UNIT	Temperature Calibration Value Units	2	S	R/W	1001 (°C)	Table 4	
55	PV_CAL_SLOPE	PV Calibration Slope	4	S	R/W	100%	40 to 150 %	
56	PV_CAL_SLOPE_UNIT	PV Calibration Slope Unit	2	N	R	1342 (%)	1342 (%)	
57	PV_CAL_OFFSET	PV Calibration Offset	4	S	R/W	0 mV	-1000 to +1000 mV	
58	PV_CAL_OFFSET_UNIT	PV Calibration Offset Unit	2	N	R	1243 (mV)	1243 (mV)	
59	PV_CAL_RESET	Reset PV Calibration	1	S	R/W	0 (OFF)	0 – OFF 1 – ON	
60	TEMP_CAL_SLOPE	Temperature Calibration Slope	4	S	R/W	100%	20 to 150 %	
61	TEMP_CAL_SLOPE_UNIT	Temperature Calibration Slope Unit	2	N	R	1342 (%)		
62	TEMP_CAL_OFFSET	Temperature Calibration Offset	4	S	R/W	0 °C	-40 to +40 °C	
63	TEMP_CAL_OFFSET_UNIT	Temperature Calibration Offset Unit	2	S	R/W	1001 (°C)	Table 4	
64	TEMP_CAL_RESET	Reset Temperature Calibration	1	S	R/W	0 (OFF)	0 – OFF 1 – ON	
65	LCD_SECONDARY	LCD Secondary Display Option	1	S	R/W	0 (Temperature in °C)	Table 5	
66	SECURITY_LOCK	Security Menu Password-enable for Keypad Operation	1	S	R/W	0 (DISABLE)	0 – Disable 1- Enable	
67	CONFIGURATION_LOCK	Configuration Menu Password-enable for Keypad Operation	1	S	R/W	0 (DISABLE)	0 – Disable 1 - Enable	

pH/ORP/pION TRANSDUCER BLOCK (cont'd)

IDX	Name	Description	Bytes	ST	AR	Default	Valid Range	Note
68	CALIBRATION_LOCK	Calibration Menu Password-enable for Keypad Operation	1	S	R/W	0 (DISABLE)	0 – Disable 1- Enable	
69	SECURITY_PASSWORD	3-digit Password for Password-enabled Keypad Operations	3	S	R/W	000	000 to 999	
70	EXTENDED_STATUS	Extended Status	7	D	R			

The Analog Input Function Block can be mapped to one out of the five outputs channels from the Transducer Block and makes this information available to other function blocks on the fieldbus network. The CHANNEL parameter selects the input from the Transducer Block. Available channels include the primary process variable (pH or mV depending on PRIMARY_VALUE_TYPE), temperature, sensor input in mV, reference electrode impedance value in kohms, and function generator output in percentage units.

The following diagram illustrates the Analog Input Function Block design. The following table lists the Analog Input Function Block parameter information.

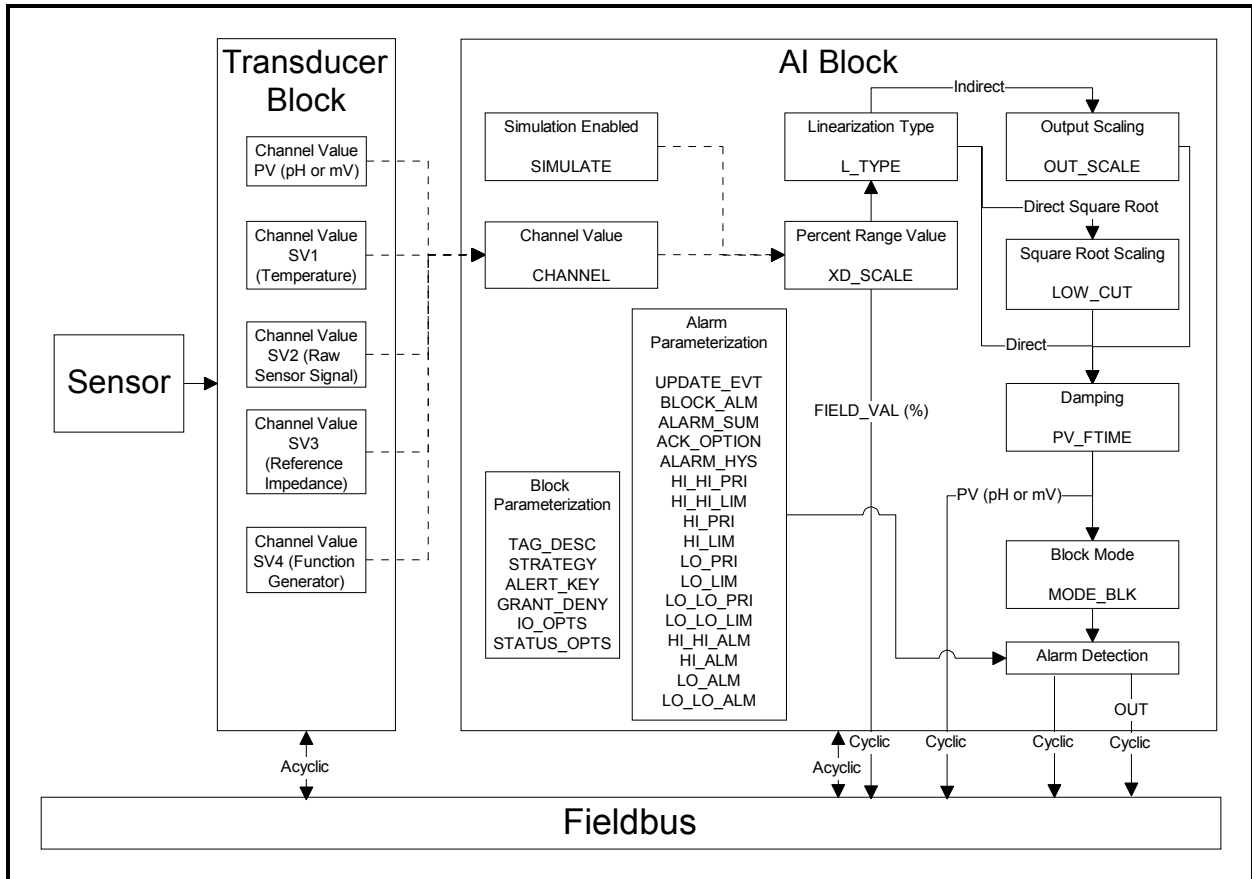

Figure 26 – Analog Input Function Block Design Diagram

ANALOG INPUT 1 - FUNCTION BLOCK

IDX	Name	Description	Bytes	ST	AR	Default	Valid Range	Note
0	BLOCK_OBJ	Block Object	62					
1	ST_REV	Static Revision	2	S	R	0		
2	TAG_DESC	TAG Description	32	S	R/W	Spaces		
3	STRATEGY	Strategy	2	S	R/W	0		
4	ALERT_KEY	Alert Key	1	S	R/W	0	1 to 255	
5	MODE_BLK	Target	1	N	R/W	OOS	OOS, Auto, Man	
		Actual	1	D	R	-		
		Permitted	1	S	R/W	OOS, Auto, Man		
		Normal	1	S	R/W	Auto	OOS, Auto, Man	
6	BLOCK_ERR	Block error	2	D	R		0 – Off 1 – On	
7	PV	Process value	4	D	R	-		
		Status	1	D	R	-		
8	OUT	Measured Value	4	N	R	-		Note E
		Status	1	D	R	-		
9	SIMULATE	Simulate Status	1	D	R/W	0		
		Simulate Value	4	D	R/W	0		
		Transducer Status	1	D	R	0		
		Transducer Value	4	D	R	0		
		Simulate Enable/Disable	1	N	R/W	1	1 – Disabled 2 – Enabled	
10	XD_SCALE	High Range	4	S	R/W	14 pH		Note F
		Low Range	4	S	R/W	0 pH		
		Unit Index	2	S	R/W	pH	Table 7	
		Decimal point	1	S	R/W	2		
11	OUT_SCALE	High Range	4	S	R/W	14 pH		Note F
		Low Range	4	S	R/W	0 pH		
		Unit Index	2	S	R/W	pH	Table 7	
		Decimal point	1	S	R/W	2		
12	GRANT_DENY	Grant	1	D	R/W	0		
		Deny	1	D	R/W	0		
13	IO_OPTS	Input / Output block options	2	S	R/W	0	Low cutoff 0 - Disable 1024 - Enable	
14	STATUS_OPTS	Status Options	2	S	R/W	64	8, 64, 128, 256	
15	CHANNEL	Channel	2	S	R/W	1	1 to 5 (or as determined by TB CHANNEL_MAP)	
16	L_TYPE	Linearization Type	1	S	R/W	1	1 to 3 Table 6	
17	LOW_CUT	Low Cut Off	4	S	R/W		Positive	
18	PV_FTIME	Filter Time	4	S	R/W	0 sec	Positive	
19	FIELD_VAL	Percent Value	4	D	R	-		
		Status	1	D	R	-		
20	UPDATE_EVT	Unacknowledged	1	D	R/W	0		
		Update State	1	D	R	0		
		Time Stamp	8	D	R	0		
		Static Revision	2	D	R	0		
		Relative Index	2	D	R	0		

ANALOG INPUT 1 - FUNCTION BLOCK (cont'd)

IDX	Name	Description	Bytes	ST	AR	Default	Valid Range	Note
21	BLOCK_ALM	Unacknowledged	1	D	R/W	0		
		Alarm State	1	D	R	0		
		Time Stamp	8	D	R	0		
		Sub-code	2	D	R	0		
		Value	1	D	R	0		
22	ALARM_SUM	Current	2	D	R	0		
		Unacknowledged	2	D	R	0		
		Unreported	2	D	R	0		
		Disabled	2	S	R/W	0		
23	ACK_OPTION	Automatic Acknowledge Option	2	S	R/W	0	0 – Disable 1 – Enable	
24	ALARM_HYS	Alarm Hysteresis	4	S	R/W	0.5%	0 to 50 %	
25	HI_HI_PRI	High-High Priority	1	S	R/W	0	0 to 15	
26	HI_HI_LIM	High-High Limit	4	S	R/W	16 pH		Note G
27	HI_PRI	High Priority	1	S	R/W	0	0 to 15	
28	HI_LIM	High Limit	4	S	R/W	16 pH		Note G
29	LO_PRI	Low Priority	1	S	R/W	0	0 to 15	
30	LO_LIM	Low Limit	4	S	R/W	-2 pH		Note G
31	LO_LO_PRI	Low-Low Priority	1	S	R/W	0	0 to 15	
32	LO_LO_LIM	Low-Low Limit	4	S	R/W	-2 pH		Note G
33	HI_HI_ALM	Unacknowledged	1	D	R/W	0		
		Alarm State	1	D	R	0		
		Time Stamp	8	D	R	0		
		Sub-code	2	D	R	0		
		Value	4	D	R	0		
34	HI_ALM	Unacknowledged	1	D	R/W	0		
		Alarm State	1	D	R	0		
		Time Stamp	8	D	R	0		
		Sub-code	2	D	R	0		
		Value	4	D	R	0		
35	LO_ALM	Unacknowledged	1	D	R/W	0		
		Alarm State	1	D	R	0		
		Time Stamp	8	D	R	0		
		Sub-code	2	D	R	0		
		Value	4	D	R	0		
36	LO_LO_ALM	Unacknowledged	1	D	R/W	0		
		Alarm State	1	D	R	0		
		Time Stamp	8	D	R	0		
		Sub-code	2	D	R	0		
		Value	4	D	R	0		

ANALOG INPUT 2 - FUNCTION BLOCK

IDX	Name	Description	Bytes	ST	AR	Default	Valid Range	Note
0	BLOCK_OBJ		62					
1	ST_REV	Static Revision	2	S	R	0		
2	TAG_DESC	TAG Description	32	S	R/W	Spaces		
3	STRATEGY	Strategy	2	S	R/W	0		
4	ALERT_KEY	Alert Key	1	S	R/W	0	1 to 255	
5	MODE_BLK	Target	1	N	R/W	OOS	OOS, Auto, Man	
		Actual	1	D	R	-		
		Permitted	1	S	R/W	OOS, Auto, Man		
		Normal	1	S	R/W	Auto	OOS, Auto, Man	
6	BLOCK_ERR	Block error	2	D	R		0 – Off 1 – On	
7	PV	Process value	4	D	R	-		
		Status	1	D	R	-		
8	OUT	Measured Value	4	N	R	-		Note E
		Status	1	D	R	-		
9	SIMULATE	Simulate Status	1	D	R/W	0		
		Simulate Value	4	D	R/W	0		
		Transducer Status	1	D	R	0		
		Transducer Value	4	D	R	0		
		Simulate Enable/Disable	1	N	R/W	1	1 – Disable 2 – Enable	
10	XD_SCALE	High Range	4	S	R/W	140 °C		Note F
		Low Range	4	S	R/W	0 °C		
		Unit Index	2	S	R/W	°C	Table 7	
		Decimal point	1	S	R/W	2		
11	OUT_SCALE	High Range	4	S	R/W	140 °C		Note F
		Low Range	4	S	R/W	0 °C		
		Unit Index	2	S	R/W	°C	Table 7	
		Decimal point	1	S	R/W	2		
12	GRANT_DENY	Grant	1	D	R/W	0		
		Deny	1	D	R/W	0		
13	IO_OPTS	Input / Output Block Options	2	S	R/W	0	Low Cut-off 0 – Disable 1024 – Enable	
14	STATUS_OPTS	Status Options	2	S	R/W	64	8, 64, 128, 256.	
15	CHANNEL	Channel	2	S	R/W	2	1 to 5 (or as determined by TB CHANNEL_MAP)	
16	L_TYPE	Linearization Type	1	S	R/W	1	1 to 3 Table 6	
17	LOW_CUT	Low Cut Off	4	S	R/W		Positive	
18	PV_FTIME	Filter Time	4	S	R/W	0 sec	Positive	
19	FIELD_VAL	Percent Value	4	D	R	-		
		Status	1	D	R	-		
20	UPDATE_EVT	Unacknowledged	1	D	R/W	0		
		Update State	1	D	R	0		
		Time Stamp	8	D	R	0		
		Static Revision	2	D	R	0		
		Relative Index	2	D	R	0		

ANALOG INPUT 2 - FUNCTION BLOCK (cont'd)

IDX	Name	Description	Bytes	ST	AR	Default	Valid Range	Note
21	BLOCK_ALM	Unacknowledged	1	D	R/W	0		
		Alarm State	1	D	R	0		
		Time Stamp	8	D	R	0		
		Sub-code	2	D	R	0		
		Value	1	D	R	0		
22	ALARM_SUM	Current	2	D	R	0		
		Unacknowledged	2	D	R	0		
		Unreported	2	D	R	0		
		Disabled	2	S	R/W	0		
23	ACK_OPTION	Automatic Acknowledge Option	2	S	R/W	0	0 – Disable 1 – Enable	
24	ALARM_HYS	Alarm Hysteresis	4	S	R/W	0.5%	0 to 50 %	
25	HI_HI_PRI	High-High Priority	1	S	R/W	0	0 to 15	
26	HI_HI_LIM	High-High Limit	4	S	R/W	140 °C		Note G
27	HI_PRI	High Priority	1	S	R/W	0	0 to 15	
28	HI_LIM	High Limit	4	S	R/W	140 °C		Note G
29	LO_PRI	Low Priority	1	S	R/W	0	0 to 15	
30	LO_LIM	Low Limit	4	S	R/W	0 °C		Note G
31	LO_LO_PRI	Low-Low Priority	1	S	R/W	0	0 to 15	
32	LO_LO_LIM	Low-Low Limit	4	S	R/W	0 °C		Note G
33	HI_HI_ALM	Unacknowledged	1	D	R/W	0		
		Alarm State	1	D	R	0		
		Time Stamp	8	D	R	0		
		Sub-code	2	D	R	0		
		Value	4	D	R	0		
34	HI_ALM	Unacknowledged	1	D	R/W	0		
		Alarm State	1	D	R	0		
		Time Stamp	8	D	R	0		
		Sub-code	2	D	R	0		
		Value	4	D	R	0		
35	LO_ALM	Unacknowledged	1	D	R/W	0		
		Alarm State	1	D	R	0		
		Time Stamp	8	D	R	0		
		Sub-code	2	D	R	0		
		Value	4	D	R	0		
36	LO_LO_ALM	Unacknowledged	1	D	R/W	0		
		Alarm State	1	D	R	0		
		Time Stamp	8	D	R	0		
		Sub-code	2	D	R	0		
		Value	4	D	R	0		

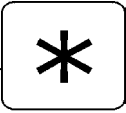

A)

TABLE 1
PRIMARY_VALUE_TYPE Codes

111 pH
114 ORP
118 PION

TABLE 2
Engineering unit codes related to PRIMARY_VALUE_TYPE

1422 pH for PRIMARY_VALUE_TYPE = 111 (pH)
1243 mV for PRIMARY_VALUE_TYPE = 114 (ORP) and 118 (PION)

TABLE 3
Valid ranges for PRIMARY_VALUE_TYPE

PRIMARY_VALUE_TYPE 111: -2 pH to 16pH
PRIMARY_VALUE_TYPE 114: -1999 to +1999mV
PRIMARY_VALUE_TYPE 118: -1999 to +1999mV

TABLE 4
Temperature Unit Codes

1001 Degree Celsius
1002 Degree Fahrenheit

TABLE 5
LCD Secondary display options

- 0 Temperature in degree Celsius (Secondary variable 1)
- 1 Temperature in degree Fahrenheit (Secondary variable 1)
- 2 Sensor input mV (Secondary variable 2)
- 3 Reference Impedance (Secondary variable 3)
- 4 Function generator output (Secondary variable 4)
- 5 Software Revision

TABLE 6
LINEARIZATION_TYPE Codes Table

- 1 Direct
- 2 Indirect
- 3 Indirect Square root

TABLE 7
AI Engineering unit codes

AI CHANNEL = PRIMARY_VALUE (Channel 1)
1422 pH for PRIMARY_VALUE_TYPE = 111 (pH)
1243 mV for PRIMARY_VALUE_TYPE = 114 (ORP) and 118 (PION)

AI CHANNEL = Temperature (Channel 2; SECONDARY_VALUE_1)
1001 Degree Celsius
1002 Degree Fahrenheit

AI CHANNEL = Sensor Input mV (Channel 3; SECONDARY_VALUE_2)
1243 mV

AI CHANNEL = Reference Impedance (Channel 4; SECONDARY_VALUE_3)
1284 K Ohm

AI CHANNEL = Function Generator output (Channel 5; SECONDARY_VALUE_4)
1342 Percent

The following figure shows the possible connections that can be made between the Transducer Block outputs and the two AI's.

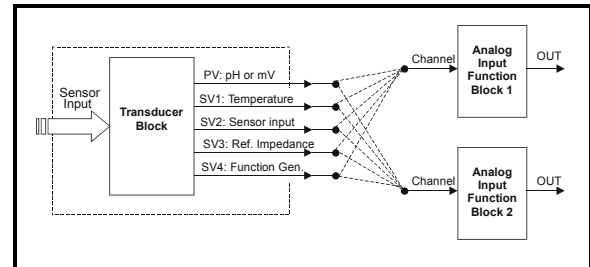

Figure 27 - Possible Connections Between the TB and AI's

The table below gives a summary of the relation between the selected measurement and available variables/channels that can be used as an input for the Analog Input Function Blocks.

	TYPE OF MEASURE (TB_PRIMARY_VALUE_TYPE)		
	pH	ORP	pION
Channel 1 (TB_PRIMARY_VALUE)	pH Value	ORP value in mV	PION value in mV
Channel 2 (TB_SECONDARY_VALUE_1)	Temperature	Temperature	Temperature
Channel 3 (TB_SECONDARY_VALUE_2)	Sensor Input in mV	Sensor Input in mV	Sensor Input in mV
Channel 4 (TB_SECONDARY_VALUE_3)	Reference Impedance in kohm	Reference Impedance in kohm	Reference Impedance in kohm
Channel 5 (TB_SECONDARY_VALUE_4)	Function Generator output in %	Function Generator output in %	Function Generator output in %

HARDWARE DIP SWITCH FUNCTIONS

There are four switches on the Microprocessor/Display PCB Assembly that perform unique transmitter functions. The figure below shows the location and function of these switches.

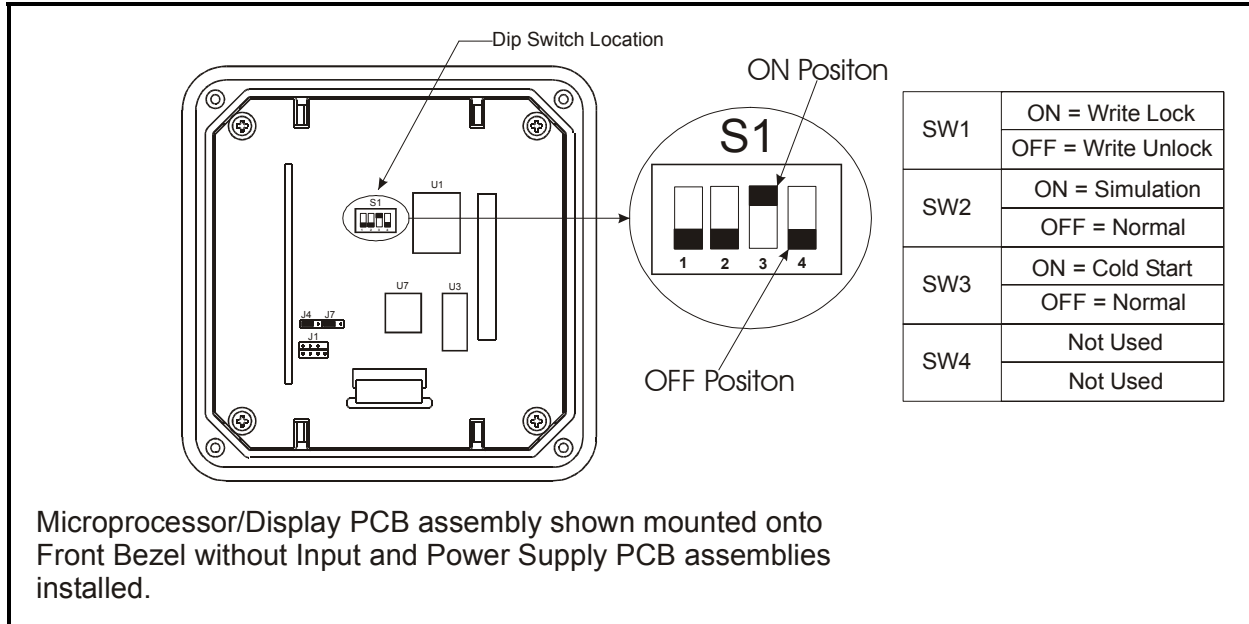

Figure 28 – Hardware Dip Switch Location and Function

Switch number 1 is the Write Lock. When this switch is in the ON position and the Hardware Write Lock is selected in the Resource Block FEATURE_SEL, the transmitter prevents any modification of data or parameters that can be performed both locally and from a class 1 or 2 MASTER device.

Switch number 2 is used to set the transmitter into Simulation mode.

Switch number 3 is used for Cold Startup. When this switch is in the ON position before powering up the transmitter, most transmitter parameters are set to default values (See Device Blocks for default settings). These default parameters are found in both the Transducer and Analog Input Function Blocks.

Switch number 4 is not used and has been reserved for future use.

Note.

A Cold Startup will adjust several parameters to a defined default value. Cold Startup may be used to reset the initial operating condition of the transmitter. When the Cold Start switch is in the ON position on transmitter power up, critical transmitter parameters will be reset to default values. The SW3 switch must be in the OFF position to ensure user configured data is not overwritten on transmitter power up.

SIMPLE FAULT FINDING

If the transmitter does not appear to be working satisfactory, carry out the following troubleshooting checks before contacting your nearest Service Center or Factory Representative.

If the instrument is to be returned for repair, ensure that it is adequately packed using the original polystyrene box or high-density chip foam. **The Return Materials Authorization (RMA) number must be sent with the instrument. Equipment returned to ABB Inc. with incorrect or incomplete information may result in significant delays or non-acceptance of the shipment.** At the time the RMA number is given, an estimate of the repair costs will be provided, and a customer purchase order will be requested. **The RMA and purchase order numbers must be clearly marked on all paperwork and on the outside of the return package container (i.e., packing box).**

Equipment needed:

FOUNDATION Fieldbus configuration software or communication Host/System

High, Low or Irregular Process Variables

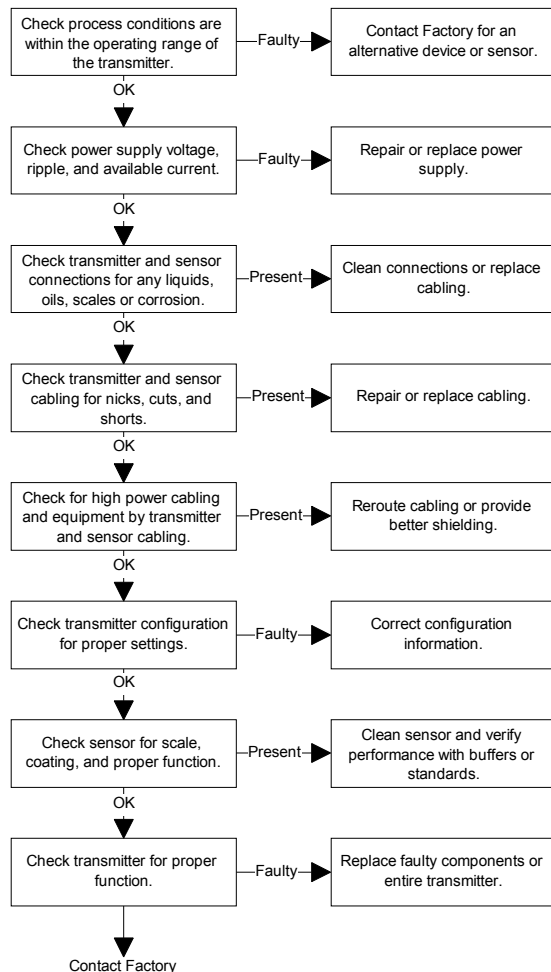

No Output

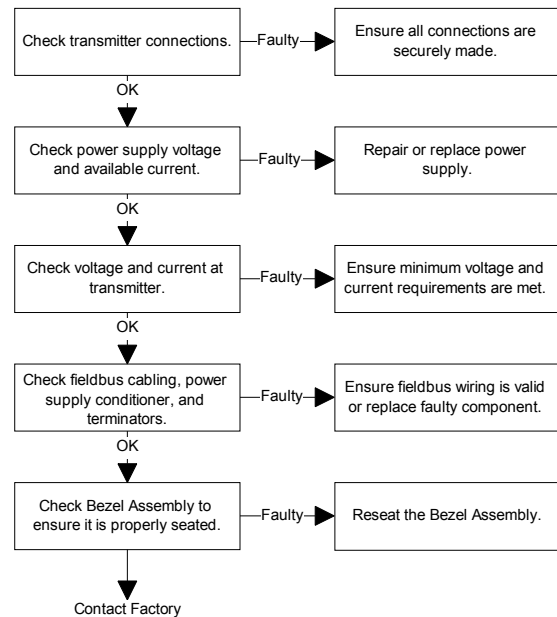

Since the transmitter has an integral display, diagnostic codes are shown in the secondary display region when interrogated using the FAULT Info key. In addition, the transmitter status is available through most configuration or system/host tools.

DIAGNOSTIC INFORMATION

The TB82PH FF transmitter performs a number of diagnostic checks on hardware, software, and sensor functions. If a nonconforming condition is detected, the user is alerted to faults locally by a flashing FAULT indicating icon and remotely by a configuration and/or system/host tool.

When using the local HMI, diagnostic faults are interrogated using the FAULT Info key in the Measure Mode. A short text string and fault code is alternately shown in the secondary display region. If multiple faults exist, the FAULT Info key moves the user to the next fault. Once all faults have been interrogated, the transmitter returns to the Measure Mode. A flashing FAULT icon indicates a new fault condition that has not been interrogated. Conversely, a non-flashing FAULT icon indicates all fault conditions have been interrogated but not resolved. When all fault conditions are resolved, the FAULT icon and FAULT Info key are de-energized.

Fault conditions are grouped into two categories based on severity. Conditions that result in degradation of transmitter performance are reported as Problem Codes (PC), while conditions that render the transmitter inoperable are reported as Error Codes (EC). Fault codes are reported in the secondary display region in a first in, first out order (i.e., the first detected fault condition is the first condition that is displayed upon interrogation). The table below lists all applicable Error and Problem codes and the suggested Corrective Actions. See Text Prompt Definitions for fault code description.

Fault Code	Fault Text String	Corrective Action
EC1	PV.AD	Contact Factory.
EC4	TC.PCB	Incorrect Input PCB assembly has been detected. Toroidal Conductivity Input PCB Assembly is being used with TB82PH product firmware.
EC5	DO.PCB	Incorrect Input PCB assembly has been detected. Dissolved Oxygen Input PCB Assembly is being used with TB82PH product firmware.
EC6	TE.PCB	Incorrect Input PCB assembly has been detected. Two-Electrode Conductivity Input PCB Assembly is being used with TB82PH product firmware.
EC7	EC.PCB	Incorrect Input PCB assembly has been detected. Four-Electrode Conductivity Input PCB Assembly is being used with TB82PH product firmware.
PC1	LO.GLS.Z	<ol style="list-style-type: none"> 1) Verify sensor wiring is properly connected. 2) Verify sensor wiring is not shorted to other wiring or metal surfaces. 3) Verify terminal blocks and other connections are free of any liquids, oils, scale or corrosion. 4) Verify configuration settings are correct. Diagnostics should be set to OFF if the sensor being used does not have a solution ground connection. 5) Verify glass electrode is intact. Replace sensor if glass electrode is broken. 6) Verify sensor responds to pH buffers. Replace sensor if sensor does not respond.
PC2	HI.REF.Z	<ol style="list-style-type: none"> 1) Verify sensor wiring is properly connected. 2) Verify sensor wiring is free of nicks, cuts, breaks and/or open connections. 3) Verify configuration settings are correct. Diagnostics should be set to OFF if the sensor being used does not have a solution ground connection. 4) Verify reference electrode is clean. Remove any foreign material. Verify sensor responds to pH buffers. Replace sensor if sensor does not response.
PC4	GND LP	<ol style="list-style-type: none"> 1) Verify sensor wiring is properly connected. 2) Verify sensor wiring is not shorted to other wiring or metal surfaces. 3) Verify terminal blocks and other connections are free of any liquids, oils, scale or corrosion. 4) If a sensor extension is being used, verify connections are dry and free of corrosion. 5) Verify configuration settings are correct. Diagnostics should be set to OFF if the sensor being used does not have a solution ground connection.
PC5	OPEN	<ol style="list-style-type: none"> 1) Verify sensor wiring is properly connected. 2) Verify sensor wiring is free of nicks, cuts, breaks and/or open connections. 3) Verify configuration settings are correct. Diagnostics should be set to OFF if the sensor being used does not have a solution ground connection.

Fault Code	Fault Text String	Corrective Action
PC8	HI.PV	1) Verify process conditions are within transmitter range values. 2) Verify sensor wiring is properly connected. 3) Verify sensor wiring is free of nicks, cuts, breaks and/or open connections. 4) Verify configuration settings are correct. 5) Verify manual or measured temperature value is correct. If a temperature sensor is not being used, verify that TMP.SNS is set to none in the transmitter configuration.
PC9	LO.PV	See PC8 corrective actions.
PC10	HI.TEMP	See PC8 corrective actions.
PC11	LO.TEMP	See PC8 corrective actions.
PC12	TEMP.AD	See PC8 corrective actions. If all items check out properly, replace Input PCB Assembly. Transmitter can be used; however, the Temperature Compensation must be set to Manual and a Temperature Calibration should be conducted in order to set the Manual Temperature Value close to the operating conditions.
PC14	+HI.OFF	1) Clean sensor and repeat a buffer and/or process calibration. If sensor is functioning properly, order a spare sensor to replace the existing sensor when failure occurs. Replace existing sensor if sensor is not functioning properly. 2) Verify sensor wiring is free of nicks, cuts, breaks, shorts and/or open connections. If wiring is damaged, replace wiring and/or sensor and recalibrate.
PC15	-HI.OFF	See PC14 corrective actions.
PC16	HI.EFF	1) Verify the proper buffer values were used for calibration. Repeat calibration with correct buffer values. 2) Clean sensor and repeat a buffer and/or process calibration. If sensor is functioning properly, order a spare sensor to replace the existing sensor when failure occurs. Replace existing sensor if sensor is not functioning properly.
PC17	LO.EFF	1) Verify the proper buffer values were used for calibration. Repeat calibration with correct buffer values. 2) Clean sensor and repeat a buffer and/or process calibration. If sensor is functioning properly, order a spare sensor to replace the existing sensor when failure occurs. Replace existing sensor if sensor is not functioning properly. 3) Verify terminal blocks and other connections are free of any liquids, oils, scale or corrosion. 4) Verify sensor wiring is free of nicks, cuts, breaks, shorts and/or open connections. If wiring is damaged, replace wiring and/or sensor and recalibrate.
PC20	BAD.SEE	Contact Factory.
PC21	NO.F.CAL	
PC23	SEE.EMI	
PC30	PV.F.CAL	
PC31	BA.F.CAL	
PC32	PT.F.CAL	
PC33	RZ.F.CAL	
PC34	PV.CHKS	
PC35	BA.CHKS	
PC36	PT.CHKS	
PC37	RZ.CHKS	
PC40	HI.R.CKT	
PC41	LO.R.CKT	
PC42	RZ.AD	
PC44	HI.G.CKT	
PC45	LO.G.CKT	
PC46	GL.AD	
PC48	HI.C.CKT	
PC49	LO.C.CKT	
PC50	CA.AD	

Calibration Diagnostic Messages

The transmitter performs automatic efficiency and offset calculations relative to a theoretically perfect electrochemical and/or temperature sensor during each calibration cycle. Calibration history is retained for future interrogation using the Edit Calibrate State. The calibration constants that are displayed are Efficiency and Offset for the Process Variable and Slope and Offset for the Temperature.

An Efficiency of less than 60% or greater than 110% indicates a potentially bad process calibration point or poorly performing sensor. Calibration values that yield Efficiency values less than 40% or greater than 150% are not accepted. In these cases, the text string BAD.CAL (bad calibration) is displayed in the secondary display region. The user is returned to the beginning of the calibration cycle after the bad calibration has been reported.

An Offset value of less than -180.0 mV or greater than +180 mV also indicates a potentially bad process calibration or poorly performing sensor. Calibration values that yield Offset values less than -1000 mV or greater than +1000 mV are not accepted. Again a

bad calibration will be reported, and the user returned to the beginning of the calibration cycle.

For temperature, a bad calibration will be reported and calibration values will not be accepted for Slope values that are less than 0.2 or greater than 1.5 and Offset values that are less than -40°C or greater than +40°C. Temperature calibrations use smart software routines that automatically adjust the Slope, Offset, or both values based on the calibration value being entered and calibration history if it exists.

Additional Diagnostic Messages

Other diagnostic messages may appear during analyzer programming. These messages include BAD.VAL (bad value) and DENIED.

BAD.VAL indicates the attempted numeric entry of a value that is out of the allowed analyzer range. See the Specifications section for analyzer range limits.

DENIED indicates incorrect entry of a security password. See the Security Mode section for information.

SENSOR TROUBLESHOOTING

If the sensor is suspected of being the source of problems, a quick visual inspection in many cases will identify the problem. If nothing can be seen, a few electrical tests using a digital multimeter can be performed to determine if the sensor is at fault. Some of these tests can be performed with the sensor either in or out of the process stream.

Visual Sensor Inspection

Remove the sensor from the process and visually check the following:

Sensor body

Inspect the sensor body for cracks and distortions. If any are found, contact your local ABB representative for alternative sensor styles and materials.

Cable and connectors

Inspect the sensor cable for cracks, cuts, or shorts. If a junction box and/or extension cable are used, check for moisture, oil, corrosion, and/or particulates. All connections must be dry, oil-free, corrosion-free, and particulate-free. Even slight amounts of moisture, skin oils, corrosion, and particulates can short sensor signals due to the high impedance of these signals. If a BNC connector is used, check to see that it is dry and not shorting against any metal, earth grounds, or conduit.

Measuring electrode

Inspect the glass electrode for breaks or cracks. If breakage is a problem, contact your local ABB representative for alternative electrode choices or suggestions regarding alternate sensor mounting locations.

Inspect the measurement electrode for foulants or scales. Many scales are not noticeable when the sensor is wet. Using a tissue, dry the glass electrode and hold it up to a bright light. Scaling will appear as a whitish, textured material on the surface of the electrode. Films will usually have a streaky, multi-colored appearance. Clean the electrode if it is fouled or scaled.

Reference junction

Inspect the reference junction (the area between the sensor body and measuring electrode) for heavy foulants or scaling. If foulants or hardness scales are present, remove foreign material. When mechanically cleaning the sensor, always use a soft bristle brush in order to avoid damaging the insulating coating on the solution ground (the metallic collar around the measuring electrode if present). This coating is only present on the outer diameter next to the reference junction and must be intact for the reference diagnostics to properly function.

If the junction (especially a wood junction) has been attacked by the process chemicals, contact your local ABB representative for alternate junction materials.

Solution ground and O-ring seals

On TBX5 sensors, inspect the solution ground (i.e., the metallic collar around the measuring electrode) and sealing O-rings for attack by the process liquid. If the solution ground shows evidence of corrosion or deterioration and/or the O-rings appear distorted or swollen, contact your local ABB representative for alternate material choices.

Sensor Electronic Test

The pH/ORP/pION sensor can be electronically tested to verify the integrity of the sensor elements and cable. These tests require a Digital Multimeter (DMM) that has a conductance function capable of measuring from 0 to 200 nS.

The sensor leads and automatic temperature compensator leads must be disconnected from the transmitter before these tests can be performed. Also the sensor must be placed in a container of water or buffer solution. If the sensor does not have a solution ground and has a BNC, the center conductor of the BNC will be equivalent to the blue Sense lead and the shell will be equivalent to the black Reference lead. Check the sensor using the following procedure.

1. Check the resistance of the Temperature Sensor. For a 3 kohm Balco RTD, the expected resistance can be calculated from:

$$R_{TC} = (((T - 25) * 0.0045) + 1) * 3000$$

where T is in degrees Celsius. The measured resistance should be within the expected value by $\pm 15\%$. At room temperature (i.e., 25°C), the resistance value should be approximately 3 kohms.

For a Pt100 RTD, the expected resistance can be calculated from:

$$R_{TC} = 100 + (T * 0.385)$$

where T is in degrees Celsius. The measured resistance should be within the expected value by $\pm 5\%$. At room temperature (i.e., 25°C), the resistance value should be approximately 110 ohms.

2. Check the conductance between the red Temperature Sensor lead and each of the other sensor leads (i.e., blue, yellow, black, green, and heavy green leads). The reading must be less than 0.05 nS.

3. Check the conductance between the yellow Guard lead and each of the other sensor leads (i.e., blue, black, green, red, white, and heavy green leads). The reading must be less than 0.05 nS.

4. Check the conductance between the heavy green lead (i.e., Shield) and each of the other sensor leads (i.e., blue, yellow, black, green, red, and white leads). The reading must be less than 0.05 nS.

5. Check the conductance of the sensor measurement electrode by measuring across the blue and green leads. The conductance must be 1 to 10 nS when the sensor and solution in contact with the sensor is at 25°C. (If the sensor and solution are above or below 25°C, the conductance value can be estimated as one-half the conductance for every eight degrees above 25°C or double the conductance for every eight degrees below 25°C.)

6. Check the voltage of the sensor reference electrode by measuring across the black lead for the sensor under test and the black lead of a known good sensor. For this test, the sensor under test must be removed from the process and placed into a buffer solution. The known good sensor must also be placed in the same buffer solution. The voltage must be between -180 mV and +180 mV.

DIAGNOSTIC INFORMATION RECEIVED FROM THE FIELDBUS

Dynamic variables and diagnostic information are continually passed onto the fieldbus during each device transmission. Most engineering tools and/or system/host workstations provide the ability to view such information. Dynamic variable status contains two components: data quality and sub-status. The following table briefly outlines the dynamic variable status.

Quality	Sub-status
Good (non-cascade)	1) Nonspecific. 2) Active alarm block. 3) Block has active advisory alarm. 4) Block has active alarm with priority > or = 8. 5) Block has unacknowledged alarm. 6) Unacknowledged advisory alarm. 7) Unacknowledged critical alarm.
Uncertain	1) Nonspecific. 2) Last usable value. 3) Substitute. 4) Initial value. 5) Sensor conversion not accurate. 6) EU range violation. 7) Sub-normal.
Bad	1) Nonspecific. 2) Configuration error. 3) Not connected. 4) Device failure. 5) Sensor failure. 6) No communication, with last usable value. 7) No communication, with no last usable value. 8) Block Out of Service.

In addition to the dynamic variable status, Block Error Parameters provide error status of hardware or software components that are associated with and/or directly impact the correct operation of the Transducer Block. The three parameters include BLOCK_ERR, block alarm sub-code, and XD_ERROR. The BLOCK_ERR parameter can have several status conditions. The block alarm sub-code and XD_ERROR parameters provide additional information on the diagnostic condition. The following table lists the possible items that can be used for these three parameters.

BLOCK_ERR	Block Alarm Sub-code	XD_ERROR
1) Other 2) Block Configuration Error 3) Link Configuration Error 4) Simulate Active 5) Local Override 6) Device Fault State Set 7) Device Needs Maintenance Soon 8) Input Failure/PV has Bad Status 9) Output Failure 10) Memory Failure 11) Lost Static Data 12) Lost NV Data 13) Readback Check Failed 14) Device Needs Maintenance Now	Any one BLOCK_ERR or XD_ERROR condition.	1) Unspecified Error 2) General Error 3) Calibration Error 4) Configuration Error 5) Electronics Failure 6) Mechanical Failure 7) I/O Failure 8) Data Integrity Error 9) Software Error 10) Algorithm Error

Transmitter diagnostic conditions (i.e., Problem and Error Codes) are displayed as Extended Status information. Since these conditions have an impact on the Dynamic Variable quality and Block parameters, each diagnostic condition has been mapped as follows:

Problem/Error Code and Text Prompt		Problem & Error Description	PV Status	SV1 Status	SV2 Status	SV3 Status	SV4 Status	TB Block_err	TB Block Alarm Sub-code	TB Xd_error
Code	Text									
EC1	PV.AD	Process Variable Over/Under Range	Bad (Device failure)	N/A	Bad (Device failure)	N/A	Bad (Device Failure)	Input Failure, Needs Maintenance Now, Other	Electronics Failure	Electronics Failure
EC3 To EC7	xx.PCB	Incorrect Input Board	Bad (Device Failure)	Bad (Device Failure)	Bad (Device Failure)	Bad (Device Failure)	Bad (Device Failure)	Input Failure, Device Needs Maintenance Now, Other	Electronics Failure	Electronics Failure
PC1	LO.GLS.Z	Low glass electrode impedance	Bad (Sensor Failure)	N/A	Bad (Sensor Failure)	N/A	Bad (Sensor Failure)	Device Needs Maintenance Now	Device Needs Maintenance Now	Device Needs Maintenance Now
PC2	HI.REF.Z	High reference electrode impedance	Uncertain (Sub-normal)	N/A	Uncertain (Sub-normal)	Uncertain (EU Range Violation)	Uncertain (Sub-normal)	Device Needs Maintenance Soon	Device Needs Maintenance Soon	Device Needs Maintenance Soon
PC4	GND.LP	Ground loops present or shorted sensor cable.	Bad (Sensor Failure)	N/A	Bad (Sensor Failure)	N/A	Bad (Sensor Failure)	Device Needs Maintenance Now	Device Needs Maintenance Now	Device Needs Maintenance Now
PC5	OPEN	Open sensor cable or sensor out of solution.	Bad (Sensor Failure)	N/A	Bad (Sensor Failure)	Uncertain (EU Range Violation)	Bad (Sensor Failure)	Device Needs Maintenance Now	Device Needs Maintenance Now	Device Needs Maintenance Now
PC8	HI.PV	PV above/below transmitter range.	Uncertain (EU Range Violation)	N/A	N/A	N/A	Uncertain (EU Range Violation)	Device Needs Maintenance Now, Other	Mechanical Failure	Mechanical Failure
PC9	LO.PV									
PC10	HI.TEMP	Temperature above/below transmitter range.	Uncertain (Sensor Conversion Not Accurate)	Uncertain (EU Range Violation)	N/A	N/A	Uncertain (Sensor Conversion Not Accurate)	Block Configuration Error, Device Needs Maintenance Now, Other	Mechanical Failure	Mechanical Failure
PC11	LO.TEMP									
PC12	TEMP.AD	Open, missing or shorted temperature sensor.	Uncertain (Sensor Conversion Not Accurate)	Bad (Sensor Failure)	N/A	N/A	Uncertain (Sensor Conversion Not Accurate)	Block Configuration Error, Device Needs Maintenance Now, Other	Configuration Error	Configuration Error
PC14	+HI.OFF	Large Positive Sensor Offset (>180mV).	Uncertain (Sub-normal)	N/A	Uncertain (Sub-normal)	N/A	Uncertain (Sub-normal)	Device Needs Maintenance Soon	Mechanical Failure	Mechanical Failure
PC15	-HI.OFF	Large Negative Sensor Offset (<-180mV).	Uncertain (Sub-normal)	N/A	Uncertain (Sub-normal)	N/A	Uncertain (Sub-normal)	Device Needs Maintenance Soon	Mechanical Failure	Mechanical Failure
PC16	HI.EFF	High Sensor Efficiency (>110%).	Uncertain (Sub-normal)	N/A	Uncertain (Sub-normal)	N/A	Uncertain (Sub-normal)	Device Needs Maintenance Soon	Calibration Error	Calibration Error
PC17	LO.EFF	Low Sensor Efficiency (<60%).	Uncertain (Sub-normal)	N/A	Uncertain (Sub-normal)	N/A	Uncertain (Sub-normal)	Device Needs Maintenance Soon	Device Needs Maintenance Soon	Device Needs Maintenance Soon
PC30 To PC37	xx.F.CAL xx.CHKS	SEE checksum and bad fac cal errors	Uncertain (Sensor Conversion Not Accurate)	Uncertain (Sensor Conversion Not Accurate)	Uncertain (Sensor Conversion Not Accurate)	Uncertain (Sensor Conversion Not Accurate)	Uncertain (Sensor Conversion Not Accurate)	Lost Static Data	Data Integrity	Data Integrity
PC40	HI.R.CKT	Reference impedance circuit failure-high/low range error.	Uncertain (Sub-normal)	N/A	Uncertain (Sub-normal)	Bad	Uncertain (Sub-normal)	Device Needs Maintenance Soon	Device Needs Maintenance Soon	Device Needs Maintenance Soon
PC41	LO.R.CKT									
PC42	RZ.AD	Reference impedance above/below transmitter A/D range.	Uncertain (Sub-normal)	N/A	Uncertain (Sub-normal)	Bad	Uncertain (Sub-normal)	Device Needs Maintenance Soon	Device Needs Maintenance Soon	Device Needs Maintenance Soon
PC44	HI.G.CKT	pH measuring electrode impedance circuit failure – high/low range error.	Uncertain (Sub-normal)	N/A	Uncertain (Sub-normal)	N/A	Uncertain (Sub-normal)	Device Needs Maintenance Soon	Device Needs Maintenance Soon	Device Needs Maintenance Soon
PC45	LO.G.CKT									
PC46	GL.AD	pH measuring electrode impedance above/below transmitter A/D range.	Uncertain (Sub-normal)	N/A	Uncertain (Sub-normal)	N/A	Uncertain (Sub-normal)	Device Needs Maintenance Soon	Device Needs Maintenance Soon	Device Needs Maintenance Soon
PC48	HI.C.CKT	Cable diagnostic circuit failure – high/low range error.	Uncertain (Sub-normal)	N/A	Uncertain (Sub-normal)	N/A	Uncertain (Sub-normal)	Device Needs Maintenance Now	Device Needs Maintenance Now	Device Needs Maintenance Now
PC49	LO.C.CKT									
PC50	CA.AD	Cable diagnostic signal above/below transmitter A/D range.	Uncertain (Sub-normal)	N/A	Uncertain (Sub-normal)	N/A	Uncertain (Sub-normal)	Device Needs Maintenance Now	Device Needs Maintenance Now	Device Needs Maintenance Now

PV represents Primary Values and SV represents Secondary Value.

The **Alert Notification** Mechanism is used to inform a master device of an error. In addition, Alert Notifications provide some information on process conditions and events and are automatically sent to a master device. So whenever an alarm or an error condition enables an Alert Notification, the alert is received at the master device as one of four reported states: Acknowledged, Unacknowledged, Reported, or Unreported.

Alarm Summary

Whenever an alarm is enabled and the alarm condition occurs, notification at the Master device is initiated by using an Alert Notification and setting the relevant bit in the Current Alarms field. The Unacknowledged field reflects if the alarm has been recognized at the Master device. The Unreported field reflects if the alarm was linked to a system at which each alarm event has to be reported.

Alarm Type	Description
Discrete Alarm	Supported only by the Resource Block. When the Hardware (Switch 1) and/or Software write locks have been set.
HI_HI_Alarm	Supported by AI. Notified when the OUT value goes above the HI_HI_LIM value and when the OUT value drops back down below the HI_HI_LIM value. Alarm state and time stamp only recorded when HI_HI_PRI is non-zero.
HI_Alarm	Supported by AI. Notified when the OUT value goes above the HI_LIM value and when the OUT value drops back down below the HI_LIM value. Alarm state and time stamp only recorded when HI_PRI is non-zero.
LO_LO_Alarm	Supported by AI. Notified when the OUT value goes below the LO_LO_LIM value and when the OUT value rises back over the LO_LO_LIM value. Alarm state and time stamp only recorded when LO_LO_PRI is non-zero.
LO_Alarm	Supported by AI. Notified when the OUT value goes below the LO_LIM value and when the OUT value rises back over the LO_LIM value. Alarm state and time stamp only recorded when LO_PRI is non-zero.
Block Alarm	Supported by RB, TB and AI. Notify when a Block Error occurrence is encountered for the relating block. See Block Error.

Limit alarm bits are set to 1 or 0. A '1' represents an active alarm and a '0' represents an inactive alarm in the Current Alarms field.

DISMANTLING AND REASSEMBLY

Warning.
 Substitution of any components other than those assemblies listed in this section will compromise the certification listed on the transmitter nameplate. Invalidating the certifications can lead to unsafe conditions that can injure personnel and damage equipment.

Caution.
 Dismantling and reassembly should not be carried out on site because of the risk of damage to components and printed circuits as a result of adverse environmental conditions such as humidity, dust, etc. The dismantling and reassembly procedures given below should be carried out in the listed order to avoid instrument damage.

Required tools

Medium flat-bladed screwdriver
 Small Phillips screwdriver

Dismantling

- Use the bladed screwdriver to loosen the four captive screws that secure the Front Bezel and/or Rear Cover Assemblies (depending on which component is being replaced) and remove the cover(s).

- Remove Power Supply and/or Input PCB Assemblies by unscrewing the two Phillips screws and unplug the assemblies from their connectors.
- Remove Microprocessor/Display PCB Assembly by unscrewing the four Phillips screws and unplug the keypad cable by lifting the locking arms on the side of the connector and remove the cable from the connector.
- Remove the cable hubs by screwing the retaining nut and removing the hub from the Shell Assembly.

Reassembly

Check that the gaskets are not damaged and have a thin layer of silicone grease. If the gaskets are damaged, replace gaskets.

- Install the Microprocessor/Display by securing the assembly with the four Phillips screws and installing the keypad cable into the connector and locking it into place by pushing down the two locking arms on the side of the connector.
- Install the Power Supply and/or Input PCB Assemblies into their respective connector and secure the assemblies with the two Phillips screws per assembly.
- Attach cable hubs by installing the gaskets onto the hubs and insert the hubs into the ports in the Shell assembly. Secure the hubs by tightening the nut onto the hub threads.
- Install the Front Bezel and/or Rear Cover Assemblies and secure by tightening the four captive screws per assembly using a bladed screwdriver.

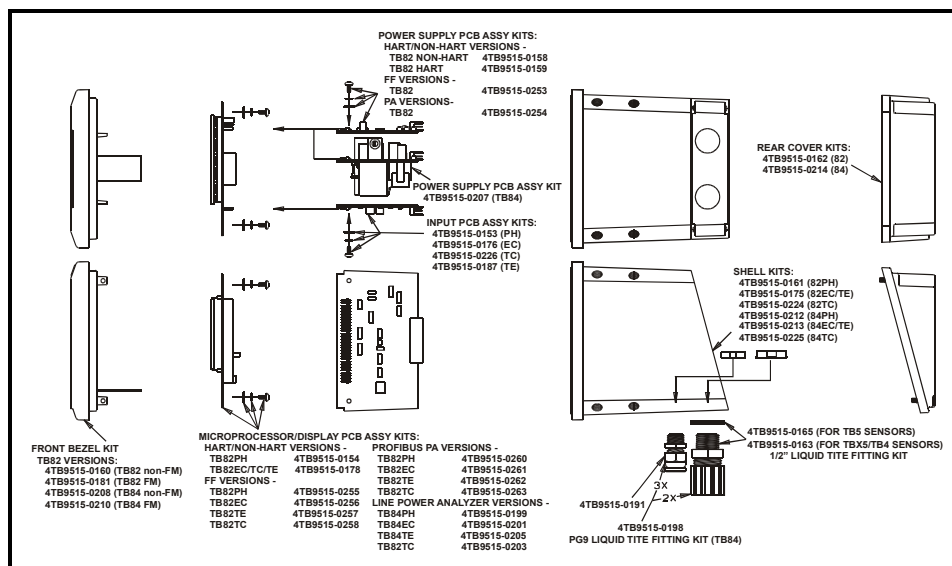

Figure 29 - TB82PH FF Transmitter Exploded View

SPECIFICATIONS

Property	Characteristic/Value
Process Display Range pH ORP pION	-2 to +16.00 pH -1999 to +1999 mV -1999 to +1999 mV
Temperature Display Range	-20 to 300°C (-4° to 572°F)
Sensor Temperature Range	0° to 140°C (32° to 284°F)
Resolution, Display pH ORP pION Temperature	0.01 pH 1 mV 1 mV 1°C, 1°F
Accuracy, Display pH ORP pION Temperature	±0.01 pH ±1 mV ±1 mV 1°C
Nonlinearity, Display pH ORP pION Temperature	±0.01 pH ±1 mV ±1 mV 1°C
Repeatability, Display pH ORP pION Temperature	±0.01 pH ±1 mV ±1 mV 1°C
Stability, Display pH ORP pION Temperature	±0.01 pH ±1 mV ±1 mV 1°C
Temperature Compensation	Manual Nernstian Automatic Nernstian Automatic Nernstian with Solution Coefficient
Input Types pH ORP pION Temperature	Glass, Antimony, Custom Isopotential & Asymmetric Potential Platinum, Gold Sodium, Chloride, Sulfide, etc. 3 kohm Balco, Pt100
Dynamic Response	3 sec. for 90% step change at 0.0 sec. damping
Ambient Temperature Effect pH ORP pION Temperature	±0.007 pH/°C @ 95% Relative Humidity ±0.4 mV/°C @ 95% Relative Humidity ±0.4 mV/°C @ 95% Relative Humidity ±0.16 °C/°C @ 95% Relative Humidity
Minimum Span pH ORP pION Temperature	1.00 pH 100 mV 100 mV 10 °C

Property	Characteristic/Value
Maximum Span (full scale settings) pH ORP pION Temperature	14 pH (0 to 14 pH) 3998 mV (-1999 to 1999 mV) 3998 mV (-1999 to 1999 mV) 140 °C, 252 °F (0 to 140 °C, 32 to 284 °F)
Damping	Continuously adjustable from 0.0 to 99.9 seconds
Supply Voltage Range	9 to 32 Vdc (9 to 24 Vdc for agency certified IS applications) 15 mA quiescent current
Turn-On Time	4 seconds typical, 6 seconds maximum
Maximum Sensor Cable Length	100 ft (30.5 m)
Sensor Diagnostic pH ORP pION	Glass and Reference Impedance, Open Cabling, Efficiency and Asymmetric Potential Check Reference Impedance, Open Cabling, Efficiency and Asymmetric Potential Check Reference Impedance, Open Cabling, Efficiency and Asymmetric Potential Check
Diagnostic Notification Local HMI	FAULT icon indication.
Environmental Operating temperature LCD Range Storage temperature	-20° to 60°C (-4° to 140°F) -20° to 60°C (-4° to 140°F) -40° to 70°C (-40° to 158°F)
Mounting Effect	None
Enclosure Classification	NEMA 4X IP65
Size Height Minimum panel depth Maximum panel cutout Recommended panel cutout	144 mm high x 144 mm wide x 171 mm long (5.67 in. high x 5.67 in. wide x 6.75 in. long) 145 mm (5.70 in.) 136.7 mm x 136.7 mm (5.38 in. x 5.38 in.) 135 mm x 135 mm (5.33 in. x 5.33 in.)
Weight	4.2 lb (1.9 kg) without mounting hardware 7.5 lb (3.4 kg) with Pipe Mounting Hardware

Property	Characteristic/Value
EMC Requirements	CE certified: Electromagnetic Conformance - IEC61326-1: 2000 EN55011: 1991 (CISPR11: 1990) Class A EN61000-4-2: 1995 4 kV Contact 6 kV Indirect EN61000-4-3: 1997 10 V/m EN61000-4-4: 1995 1 kV EN61000-4-5: 1995 2kV Line to Earth 1kV Line to Line EN61000-4-6: 2001 3V EN61000-4-8: 1994 30A/m
Agency Approvals ¹ (pending) Factory Mutual (FM) Intrinsic safety Nonincendive Canadian Standards Association (CSA) Intrinsic safety Nonincendive CENELEC (Conforms with ATEX 100A) Intrinsic safety	Class I, II, III; Division 1; applicable Groups A, B, C, D, E, F and G; T4 when used with appropriate barriers per Drawing PXXXX. Class I, Division 2, Groups A, B, C, and D. Class II, Division 2, Groups E, F and G. Class III, Division 2. Class I, II, III; Division 1; applicable Groups A, B, C, D, E, F and G; T4 when used with appropriate barriers per Drawing PXXXX. Class I, Division 2, Groups A, B, C, and D. Class II, Division 2, Groups E, F and G. Class III, Division 2. ATEX Category II 1G EEX ia, Zone 1; Group IIC, T4 when used with appropriate barriers.

¹ Hazardous location approvals for use in flammable atmospheres are for ambient conditions of -20C to 60 C (-4 F to 140 F), 86 to 108 kPa (12.5 to 15.7 psi) with a maximum oxygen concentration of 21%.

GLOSSARY OF PROGRAMMING TEXT PROMPTS

TEXT STRING	DESCRIPTION
1PT.CAL	One Point Calibration.
2PT.CAL	Two Point Calibration.
3K.BLCO	3 kohm Balco (Temperature Compensation).
AI-.BLK	Analog Input Block where '-' is the block number.
AI-.FV	Analog Input Field Value where '-' is the block number.
AI-.OUT	Analog Input Output value where '-' is the block number.
AI-.PV	Analog Input Process Value where '-' is the block number.
ANALZR	Analyzer State.
ANTMNY	Antimony (pH Sensor with Antimony Measurement Electrode).
ASY.POT	Asymmetric Potential.
AUT.SOL	Automatic Temperature Compensation (Nernstian) with Solution Coefficient.
AUTO	Automatic Temperature Compensation (Nernstian) or Automatic Block Mode Handling.
BAD.CAL	Bad Calibration - Entered values caused the calculated values to exceed maximum values.
BAD.VAL	Bad Value - Entered value exceeded maximum allowable value for the entered parameter.
CALIBR	Calibrate Mode.
CONFIG	Configure Mode.
CUSTOM	Custom Measurement Electrode with adjustable Isopotential Point and Asymmetric Potential (pH Sensor with Custom Measurement Electrode).
DAMPNG	Damping of the displayed primary value on the transmitter's HMI.
DIAGS	Diagnostics State.
DISABL	Disable.
EDT.CAL	Edit Calibrate State.
ENABLE	Enable.
FF.ID	Foundation Fieldbus Identification.
HARD.LK	Operation cannot be completed due to Hardware write protection.
HI.VAL	High Calibration (Buffer or Standard) Value.
ION.CAL	Specific Ion Calibration.
ISO.PT	Isopotential Point.
---KRZ	Reference Impedance in kohms where '---' is the impedance value.
LIN.TYP	Linearity Type (Linear or Function Generator).
LO.VAL	Low Calibration (Buffer or Standard) Value.
MANUAL	Manual Temperature Compensation (Nernstian).
MODIFY	Modify Configure State.
MV/10C	Millivolt per 10°C (Solution Coefficient value for Automatic Nernstian with Solution Coefficient Temperature Compensation).
NEW.VAL	New Calibration Value - The PV or Temperature value expected during a One Point or Temperature Calibration.
NEW.VL.C	New Temperature Value in degrees Celsius.
NEW.VL.F	New Temperature Value in degrees Fahrenheit.
NONE	None.
OFFSET	Offset Value.
OOS	Out Of Service.
ORP	Oxidation-Reduction Potential Analyzer Type.
ORP.CAL	ORP Calibration State.
OUTPUT	Output Mode.
PASSWD	Security Password.
PH	pH Analyzer Type.
PH/10C	pH units per 10°C (Solution Coefficient value for Automatic Nernstian with Solution Coefficient Temperature Compensation).
PH.CAL	pH Calibration State.
PH.GLAS	pH Glass (pH Sensor with Glass Measurement Electrode).
PION	Potential of a Specific Ion.
PT 100	Pt100 Ohm RTD.

TEXT STRING	DESCRIPTION
PV.OFF	Process Variable Offset Value for the installed sensor.
PV.SLP	Process Variable Slope Value for the installed sensor.
REF.Z	Reference Impedance.
RESET?	Query to Reset parameters to default values.
REV.A10	Software Revision A10.
RST.ALL	Reset All Parameters to Factory Settings.
RST.CAL	Reset Calibration Constant and Data to Factory Settings.
RST.CON	Reset Configurations to Factory Defaults.
RST.SEC	Reset Security - Remove any existing security.
RST.SFT	Software Reset - Initiate a reboot and self-test function.
SEC.DSP	Secondary Display Mode.
SECUR	Security Mode.
SLOPE	Slope for the installed sensor (Process Variable or Temperature).
STABL?	Is the displayed Process Variable Stable?
TB.OOS?	Transducer Block will be put Out Of Service?
TB.PV.LO	Transducer Block Process Value Low Range Value.
TB.PV.HI	Transducer Block Process Value High Range Value.
TB.RNGE	Transducer Block Range Value State.
TC.TYPE	Temperature Compensation Type State
T.OFF°C	Temperature Sensor Offset Value in degrees Celsius.
T.OFF°F	Temperature Sensor Offset Value in degrees Fahrenheit.
TMP.CAL	Temperature Calibration State.
TMP.SLP	Temperature Slope Value.
TMP.SNS	Temperature Sensor Type State.
TMP°C	Temperature in degrees Celsius.
UNITS	Units.
USER	User State.
VIEW	View Current Configuration.
WRT.ERR	Error saving data.
X-1	Non-linear Input Value for the first point (numeric value changes for each point).
Y-1	Non-linear Output Value for the first point (numeric value changes for each point).

TB82PH WORKSHEET

Tag: _____	Date: _____	
Analyzer Type:		
<input type="checkbox"/> pH <input type="checkbox"/> GLASS <input type="checkbox"/> ANTIMONY <input type="checkbox"/> CUSTOM ISO PT: _____ pH ASY POT: _____ mV REF Z: _____ kohm	<input type="checkbox"/> ORP REF Z: _____ kohm	<input type="checkbox"/> pION REF Z: _____ kohm
Temperature Sensor: <input type="checkbox"/> None <input type="checkbox"/> 3k Balco <input type="checkbox"/> Pt100		
Temperature Compensation Type: <input type="checkbox"/> Manual <input type="checkbox"/> Auto <input type="checkbox"/> Auto Solution <div style="text-align: right;">Coeff.: _____</div>		
Diagnostics: <input type="checkbox"/> Enabled <input type="checkbox"/> Disabled		
Security: <input type="checkbox"/> Configure <input type="checkbox"/> Calibrate <input type="checkbox"/> Security Password: _____		

Factory Default Settings		
Software		Hardware
Analyzer	Type: pH, Glass	Microprocessor/Display PCB SW1 (Hardware Lockout): OFF, Disable Lockout SW2 (Simulation): OFF, Disable Simulation SW3 (Cold Start): OFF, Disable Cold Start SW4 (Not Used): OFF
Temperature Sensor	Type: 3k, Balco	
Temperature Compensation	Type: Manual	
Linearity Type	Linear	
Sensor Diagnostics	State: Disable	

PRODUCTS & CUSTOMER SUPPORT

A Comprehensive Instrumentation Range

Analytical Instrumentation

- **Transmitters**

On-line pH, conductivity, and dissolved oxygen transmitters and associated sensing systems.

- **Sensors**

pH, redox, selective ion, conductivity and dissolved oxygen.

- **Laboratory Instrumentation**

pH and dissolved oxygen meters and associated sensors.

- **Water Analyzers**

For water quality monitoring in environmental, power generation and general industrial applications including: pH, conductivity, ammonia, nitrate, phosphate, silica, sodium, chloride, fluoride, dissolved oxygen, hydrazine, and turbidity.

- **Gas Analyzers**

Zirconia, katharometers, hydrogen purity and purge-gas monitors, thermal conductivity.

Controllers & Recorders

- **Controllers**

Digital display, electronic, pneumatic. Discrete single-loop and multi-loop controllers which can be linked to a common display station, process computer or personal computer.

- **Recorders**

Circular and strip-chart types (single and multi-point) for temperature, pressure, flow and many other process measurements.

Electronic Transmitters

- **Smart & Analog Transmitters**

Draft, differential, gauge and absolute pressure measurement. Also, liquid level and temperature.

- **I to P Converters and Field Indicators**

Flow Metering

- **Magnetic Flowmeters**

Electromagnetic, insertion type probes and water meters.

- **Turbine Flowmeters**

- **Wedge Flow Elements**

- **Mass Flow Meters**

Transmitters, sensors, controllers and batch/display units.

Level Control

- **Submersible, Capacitance & Conductivity.**

Pneumatic Instrumentation

- **Transmitters**

- **Indicating Controllers**

- **Recording Controllers**

Customer Support

ABB Instrumentation provides a comprehensive after sales service via a Worldwide Service Organization. Contact one of the following offices for details on your nearest Service and Repair Center.

United States of America

ABB Incorporated
9716 S. Virginia Street, Suite E
Reno, Nevada 89511
USA

Tel: +1 775 850 4800

Fax: +1 775 850 4808

www.abb.com/instrumentation

United Kingdom

ABB Limited
Oldends Lane, Stonehouse
Gloucestershire

GL10 3TA

UK

Tel: +44 (0) 1453 826661

Fax: +44 (0) 1453 829671

www.abb.com/instrumentation

Client Warranty

Prior to installation, the equipment referred to in this manual must be stored in a clean, dry environment, in accordance with the Company's published specification. Periodic checks must be made on the equipment's condition.

In the event of a failure under warranty, the following documentation must be provided as substantiation:

1. A listing evidencing process operation and alarm logs at time of failure.
2. Copies of operating and maintenance records relating to the alleged faulty unit.



TROUBLE SHEET

WARRANTY REPAIR REPAIR ORDER

Rejection or discrepancy reports

Copy attached Not available

• IDENTIFICATION

Customer
Purchase order No.
Plant
Name of person to contact
Instrument Nomenclature
Model
Serial Number

• OPERATING CONDITIONS

Specify location, environmental conditions, type of service and approximate number of operating hours or date of installation if known.

• REASON FOR RETURN

Trouble found during:

Installation

Commissioning

Maintenance

At start up

On service

Shipping information for the return of the equipment

Material returned for factory repair, should be sent to the nearest ABB Service Center, transportation charges prepaid by the Purchaser.

Please enclose this sheet duly completed to cover letter and packing list

Date	Signature	Originator
------	-----------	------------

EC DECLARATION OF CONFORMITY

ABB Incorporated
9716 S. Virginia Street, Suite E
Reno, Nevada 89511
USA

We declare under our sole responsibility that the product:

TB82PH Foundation Fieldbus Transmitter Series

is in conformity with the following standards:

Electromagnetic Conformance - IEC61326-1: 2000

EN55011: 1991 (CISPR11: 1990)	Class A
EN61000-4-2: 1995	4 kV Contact
	6 kV Indirect
EN61000-4-3: 1997	10 V/m
EN61000-4-4: 1995	1 kV
EN61000-4-5: 1995	2kV Line to Earth
	1kV Line to Line
EN61000-4-6: 2001	3V
EN61000-4-8: 1994	30A/m

following the provisions of the EMC Directives 89/336/EEC and 93/68/EEC.

ABB Incorporated
Technical Manager
Stewart Thoeni

ABB (www.abb.com) is a leader in power and automation technologies that enable utility and industry customers to improve performance while lowering environmental impact. The ABB Group of companies has Sales & Customer Support expertise in over 100 countries worldwide.

The Company's policy is one of continuous product improvement and the right is reserved to modify the information contained herein without notice.

Printed in USA (01.2006)

© ABB 2006

www.abb.com/instrumentation



ABB Inc.
Analytical Instrumentation
9716 S. Virginia Street, Suite E
Reno, Nevada 89511
USA
Tel: +1 775 850 4800
Fax: +1 775 850 4808

ABB Inc.
125 East County Line Road
Warminster
PA 18974-4995
USA
Tel: +1 215 674 6000
Fax: +1 215 674 7183

ABB Limited
Oldends Lane, Stonehouse
Gloucestershire
GL 10 3TA
UK
Tel: +44 (0) 1453 826661
Fax: +44 (0) 1453 829671

I-E67-TB82FF-1B